



California ISO

Your Link to Power

10 Year

Anniversary 1998-2008

Transmission Projects Seeking ISO Approval Greater Bay Area

Nisar A. Shah

Senior Regional Transmission Engineer

2009 CAISO Transmission Plan Stakeholder Meeting

February 27, 2009

Overview of 2008 Request Window

- A total of 16 projects were submitted for the Greater Bay Area through Request Window by PG&E
- CAISO Staff recommends ISO Management approval for 9 projects
- CAISO Staff recommends further review on the remaining 7 projects

Projects Recommended for CAISO Management Approval

(1) Cooley Landing - Los Altos 60 kV Line Reconductor

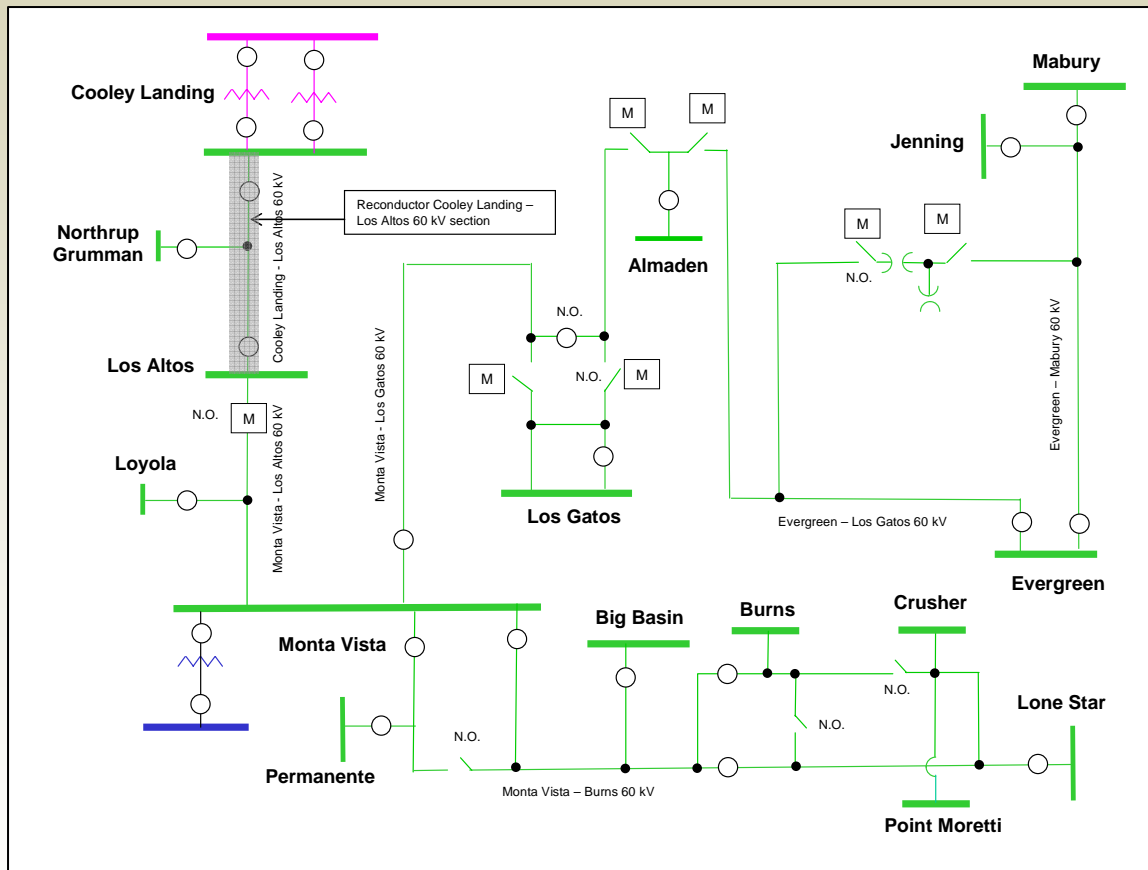

Project Proponent: PG&E

Need

- Mitigate NERC Category B overloads (2013 thru 2018)

Project Scope

-Reconductor Cooley Landing – Los Altos 60 kV line (~ 11 miles) with a conductor 800 amps or greater

-Environmental and land permits may be required

-Line terminal equipment may need to be upgraded

Costs

-Between \$5M and \$10M

Other Considered Alternatives

-Take no action

Expected In-Service

-May 2013

Recommended Action

- Approval by CAISO Management

(2) San Mateo-Bair 60 kV Line Reconductor

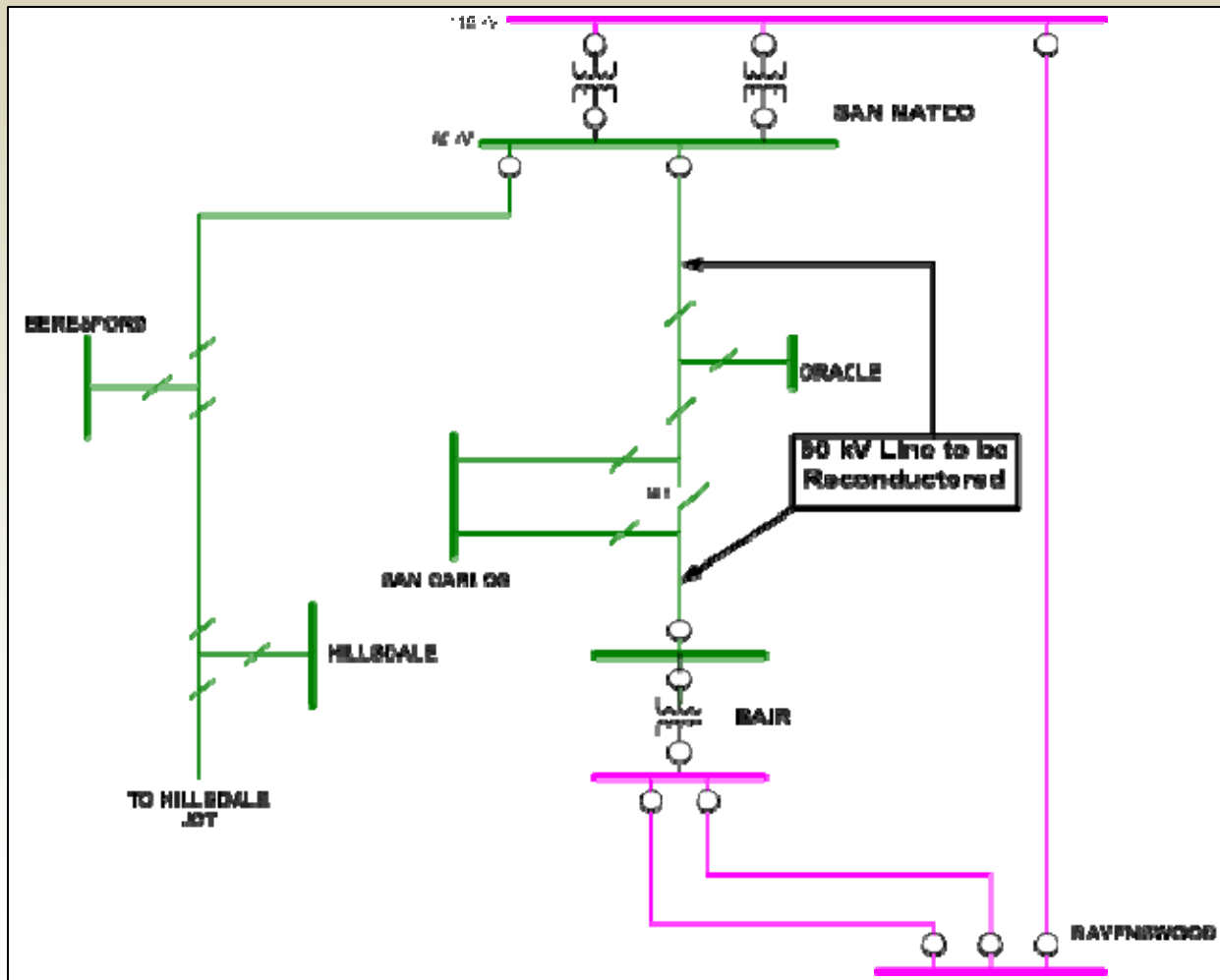

Project Proponent: PG&E

Need

- Mitigate NERC Category B and Category C overloads (2018)

Project Scope

- Reconductor San Mateo - Bair 60 kV line (~11 miles) with a conductor 1100 amps or greater
- Line terminal equipment may need to be upgraded
- Environmental and land permits may be required

Costs

- Between \$5M and \$10M

Other Considered Alternatives

-Take no action

Expected In-Service

-May 2013

Recommended Action

- Approval by CAISO Management

(3) Evergreen - Mabury 60 kV to 115 kV Conversion

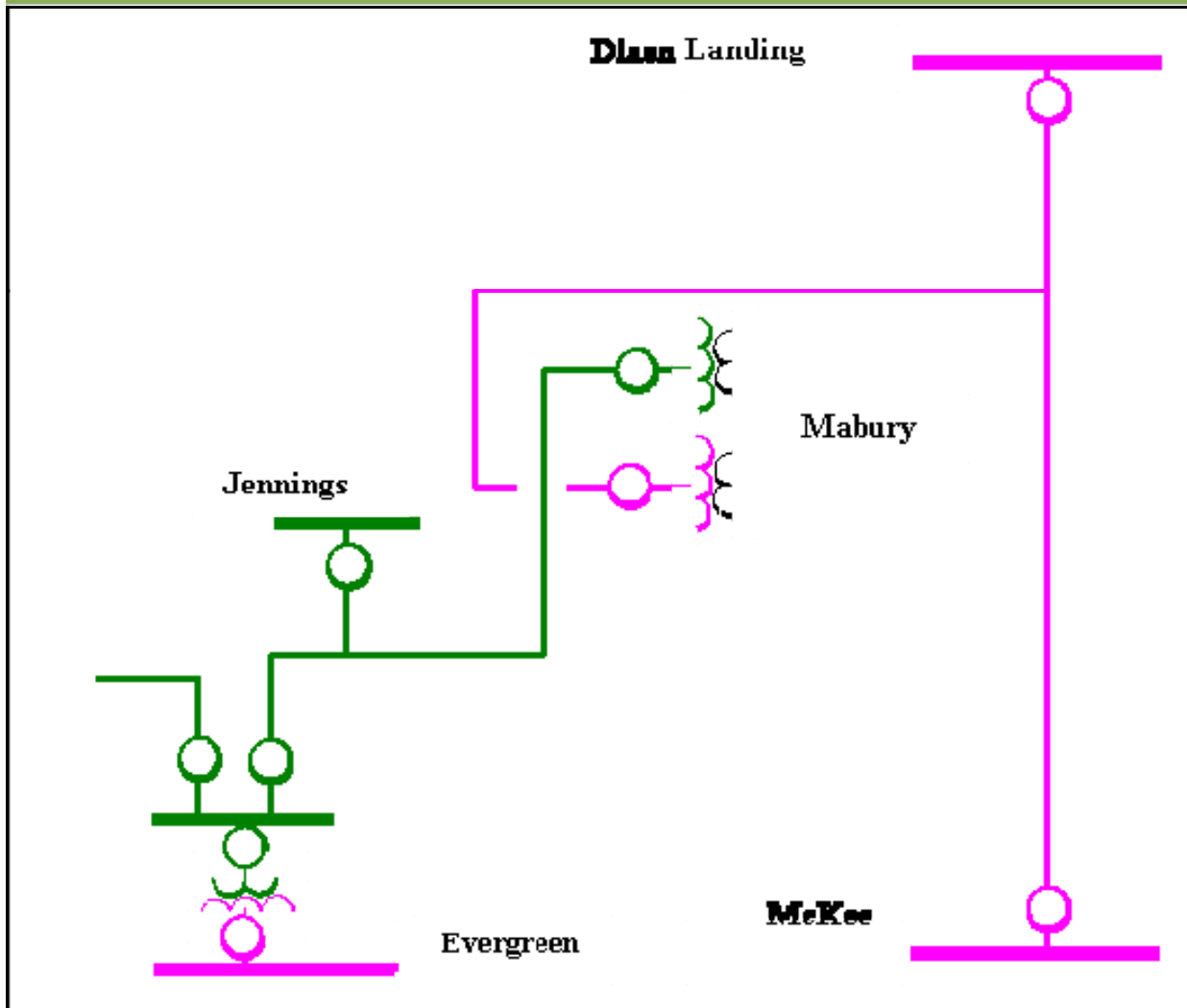

Project Proponent: PG&E

Need

- Mitigate NERC Category B and Category C overloads (2013 thru 2018)

Project Scope

- Convert Mabury Substation from 60 kV to 115 kV
- Rebuild Evergreen-Mabury 60 kV line (~6 miles) into a 115 kV circuit with conductors rated 800 amps or greater

Costs

- Between \$10M and \$15M

Other Considered Alternatives

-None

Expected In-Service

-May 2012

Recommended Action

- Approval by CAISO Management

(4) Menlo Area 60 kV system upgrade

Project Proponent: PG&E

Need

- Mitigate NERC Category B and Category C overloads (2013 thru 2018)

Project Scope

- Replace fifteen 600 amp switches with 1200 amp switches
- Upgrade limited components on the Jefferson-Stanford and Cooley Landing-Stanford 60 kV lines
- Reconductor 60 kV buses at Glenwood and Menlo substations
- Reconductor Glenwood-Menlo 60 kV line with conductor rated at 1100 amps or greater

Costs

- Between \$5M and \$10M

Other Considered Alternatives

-None

Expected In-Service

-May 2010

Recommended Action

- Approval by CAISO Management

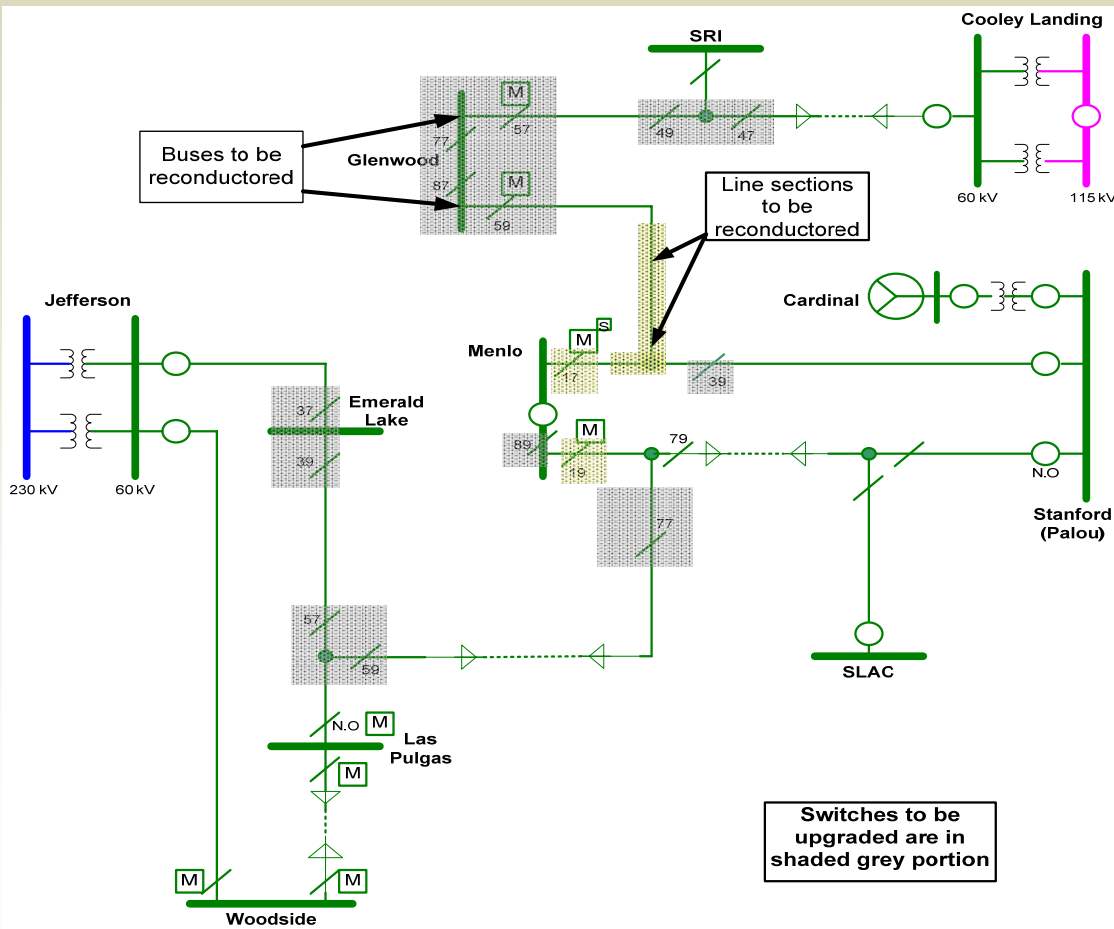

(5) Monta Vista-Los Gatos-Evergreen 60 kV project

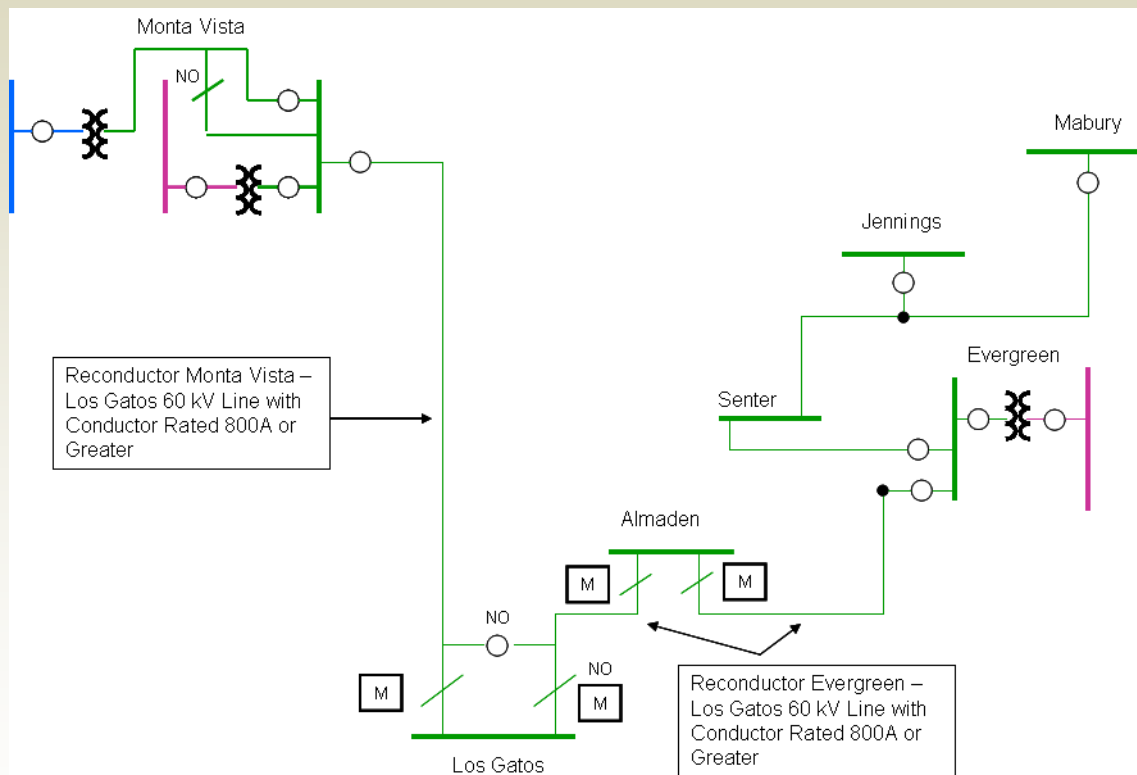

Project Proponent: PG&E

Need

- Mitigate NERC Category B overloads (2013 thru 2018)

Project Scope

-Reconductor limited sections of Monta Vista-Los Gatos (~9 miles) and Evergreen-Los Gatos (~11 miles) 60 kV lines with a conductor rated for 800 amps or greater

-Line terminal equipment may need to be upgraded

-Environmental and land permits may be required

-Costs

- Between \$10M and \$15M

Other Considered Alternatives

-Take no action

Expected In-Service

-May 2018

Recommended Action

- Approval by CAISO Management

(6) Ravenswood-Cooley Landing 115 kV Reconductor

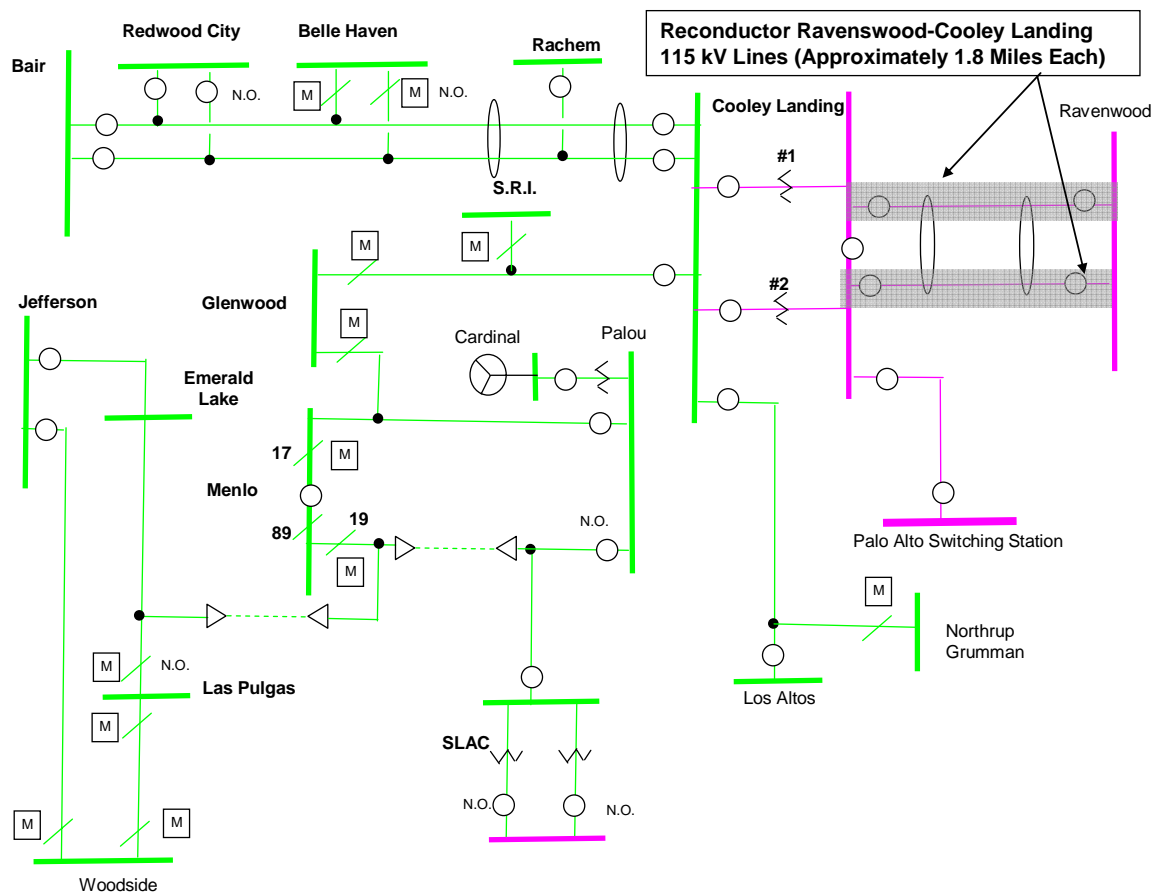

Project Proponent: PG&E

Need

- Mitigate NERC Category B overloads (2013 thru 2018)

Project Scope

-Reconductor Ravenswood-Cooley Landing 115 kV lines #1 and #2 (~1.8 miles each) with a conductor rated at 1100 amps or greater

Costs

- Between \$5M and \$10M

Other Considered Alternatives

Take no action

Expected In-Service

-May 2012

Recommended Action

- Approval by CAISO Management

(7) Tri-Valley Voltage Control

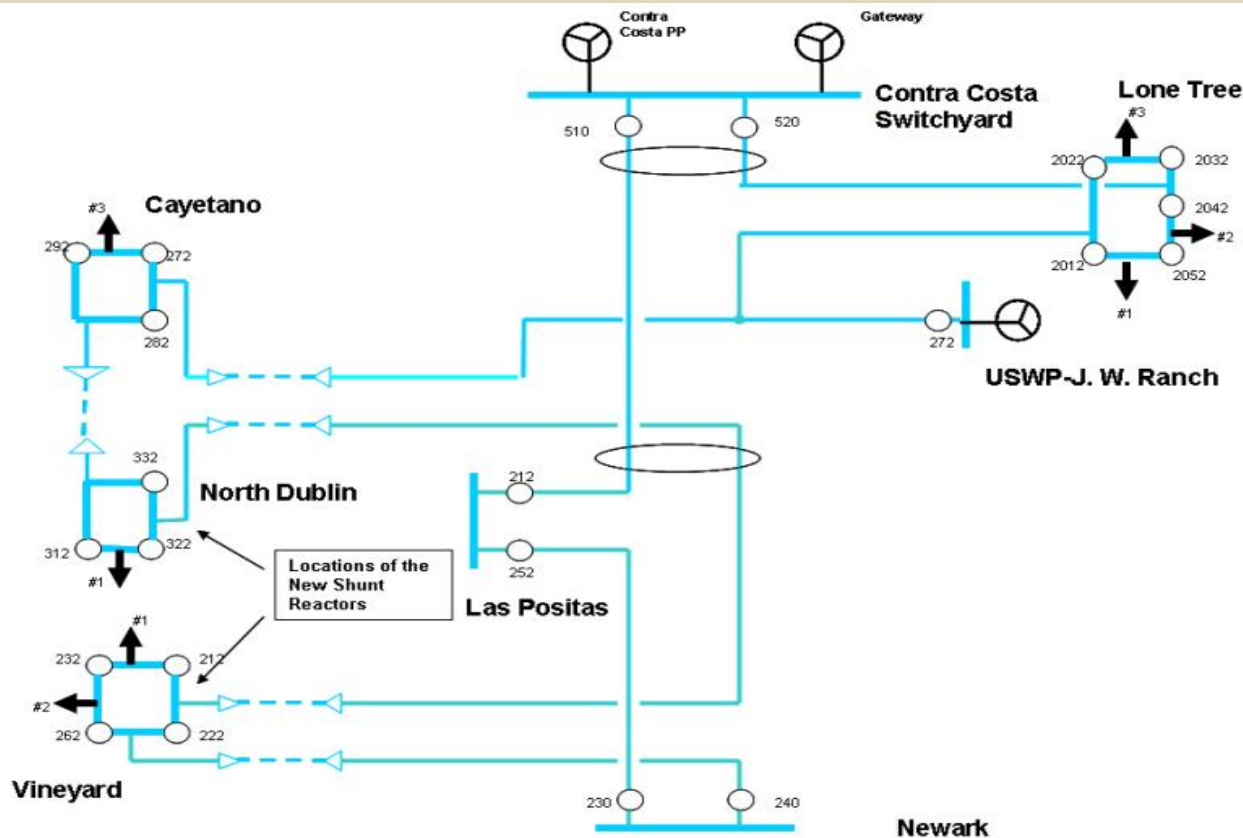

Project Proponent: PG&E

Need

- Mitigate NERC Category B Voltage violation (voltage on 230 kV system could rise to 112%)
- Operating flexibility

Project Scope

- Install two 48 MVAR shunt reactors at Vineyard sub and one 48 MVAR shunt reactor at Dublin sub
- Substation terminal equipment may be upgraded

Costs

- Between \$10M and \$15M

Other Considered Alternatives

- 150 MVARs shunt reactors on N.Dublin-Vineyard 230 kV line, or
- Loop N.Dublin-Vineyard 230 kV line into Las Positas sub

Expected In-Service

- November 2010

Recommended Action

- Approval by CAISO Management

(8) Daly City Bus Reconfiguration

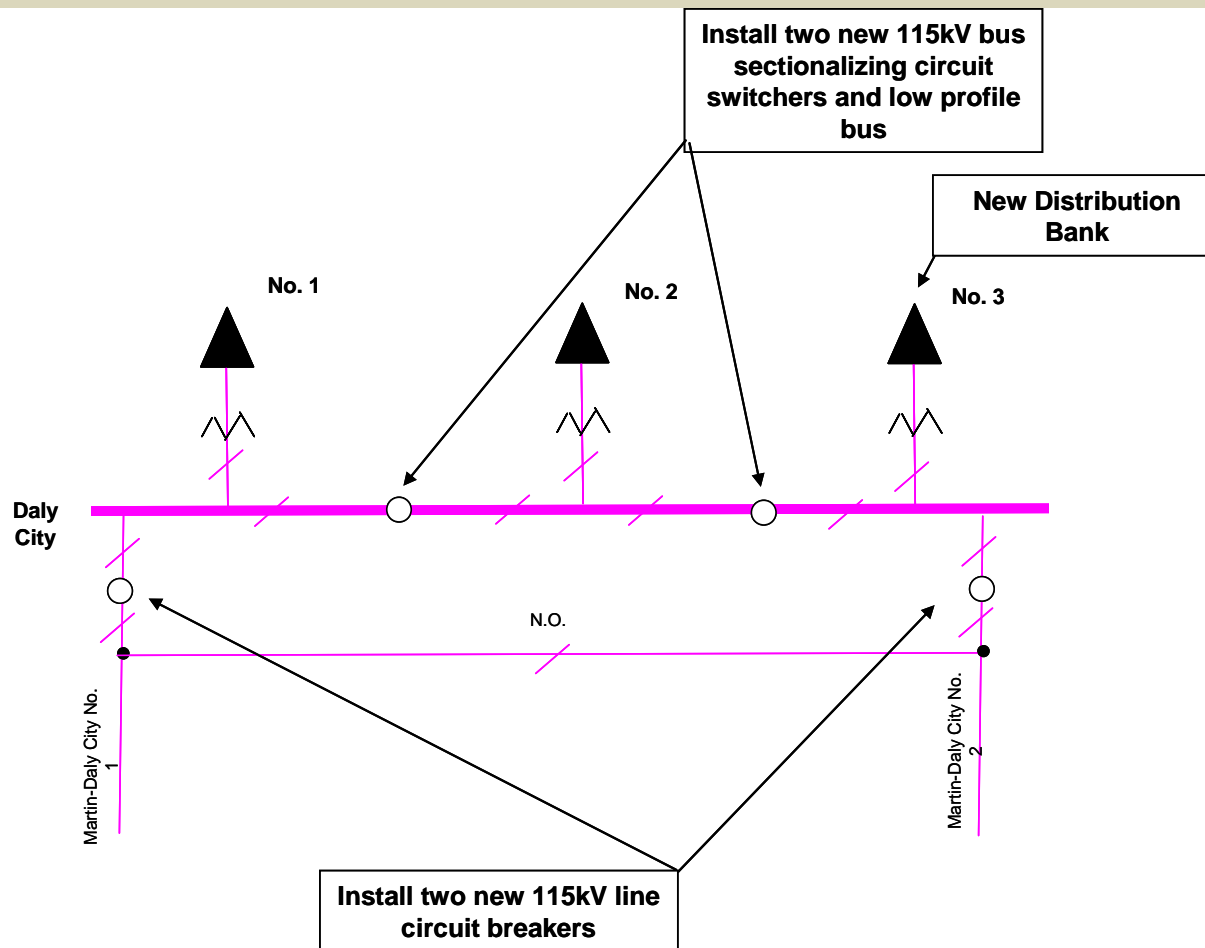

Project Proponent: PG&E

Need

- Avoid degradation of substation reliability when a third transformer is added
- NERC Compliance

Project Scope

- Install two new 115 kV line circuit breakers with SCADA, two bus sectionalizing circuit breakers with SCADA, disconnect switches and a low profile 115 kV bus at Daly City substation.

Costs

- Between \$5M and \$10M

Other Considered Alternatives

- None

Expected In-Service

- December 2010

Recommended Action

- Approval by CAISO Management

(9) Larkin Circuit Breaker No. 192

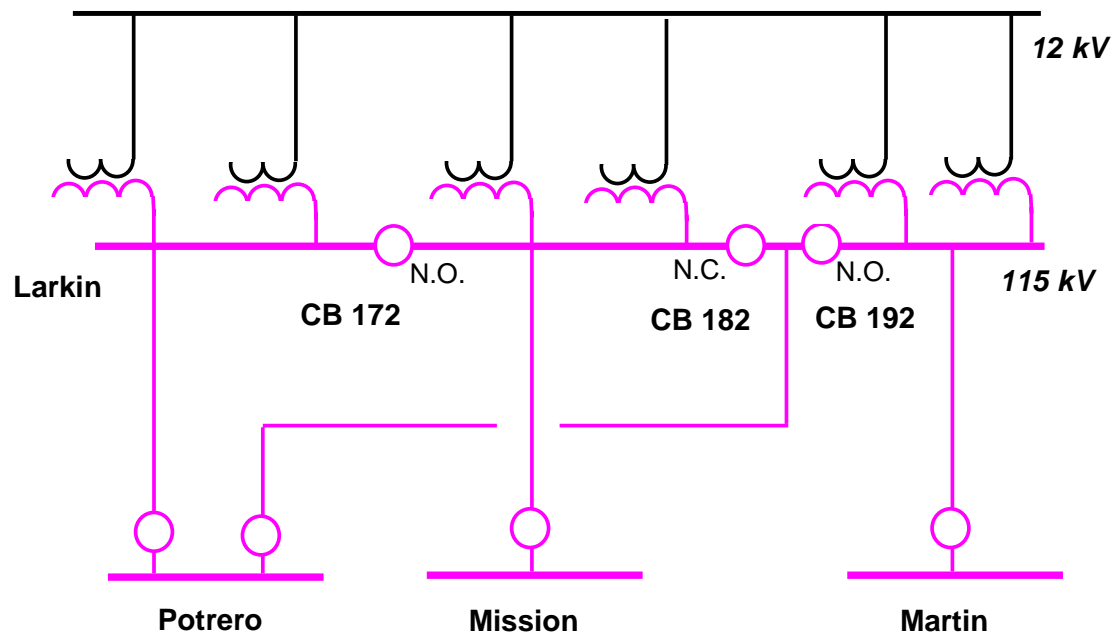

Project Proponent: PG&E

Need

- Operational Flexibility
- Balance line flows at Martin Substation
- ISO recommended in Short Term Plan

Project Scope

- Operate Larkin CB 192 normally closed
- Install CTs and overcurrent relays on distribution transformers at Larkin
- Adjust CT ratios at Martin, Potrero and Mission substations

Costs

- Between \$1M and \$5M

Other Considered Alternatives

Take no action

Expected In-Service

-March 2009

Recommended Action

- Approval by CAISO Management

On-going Projects

- Bay Area Bulk Transmission
- Contra Costa Substation Reliability Improvement Plan
- East Bay - Potrero 230 kV Transmission
- Embarcadero- Potrero 230 kV Transmission
- Metcalf-Morgan Hill 115 kV Reinforcement Project
- Oakland Area Long-term Plan
- Vaca Dixon - Sobrante - Moraga 230 kV Reinforcement