



California ISO
Your Link to Power

10 Year Anniversary 1998-2008

Transmission Projects Seeking Approval San Joaquin Valley Area

Tim Schiermeyer

Regional Transmission Engineer

2009 CAISO Transmission Plan Stakeholder Meeting

February 27, 2009

Overview of 2008 Request Window

- CAISO has proposed a total of 32 solutions to address the potential criteria violations in the San Joaquin Valley area
- In response to CAISO study results and proposed solutions:
 - 21 project submissions were received through the 2008 Request Window
 - 3 submissions have been withdrawn
 - 2 submissions have been denied
- CAISO Staff recommends ISO Management approval of 7 projects
- CAISO Staff recommends further review on the remaining 11 ongoing projects, some of which will require policy review

Projects Recommended for CAISO Management Approval

- Caruthers-Kingsburg 70kV Line Reconductor
- Guernsey-Henrietta 70kV Line Reconductor
- Herndon 115kV Circuit Breaker Replacement Project
- Herndon 230/115kV Transformer Project
- Sanger-Reedley 70kV to 115kV Conversion Project
- Sanger-California Ave 70kV to 115kV Conversion Project
- Shepherd Substation Interconnection Project

(1) Caruthers – Kingsburg 70kV Line Reconductor Project

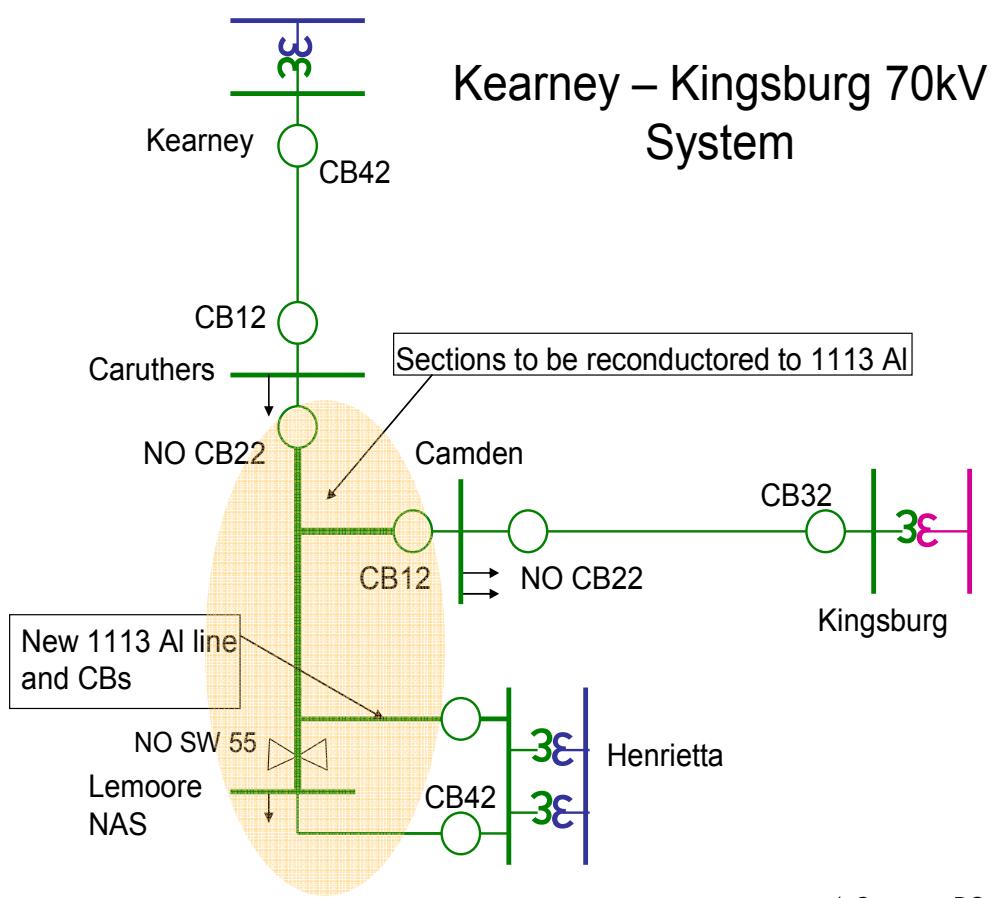

* Source: PG&E

Project Proponent

- PG&E

Needs

- NERC Category A
- Reduce outage exposure by allowing Camden and Caruthers to operate as Flip-Flop Stations
- To support anticipated additional load for Agricultural Internal Combustion Engine Conversion

Project Scope

- Reconductor Camden-Camden Junction, Camden Junction-Caruthers, and Camden Junction-Lemoore Naval Air Station 70kV lines with 1113 AI.
- Double circuit the Henrietta-Lemoore NAS 70kV line.

Costs

-\$15 to \$25 Million

Other Considered Alternatives

- Reconductor the Kingsburg-Camden 70kV Line

Expected In-Service

- May 2012

Recommended Action: Approval by CAISO Management

(2) Guernsey – Henrietta 70kV Line Reconductor

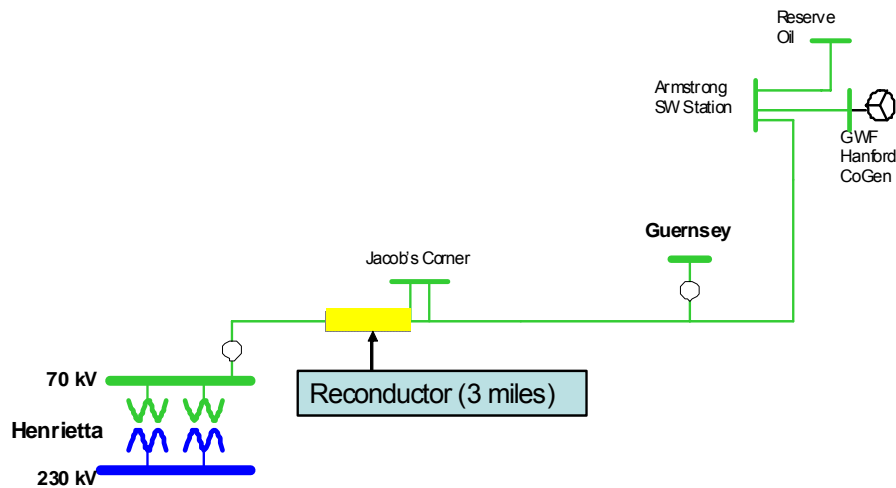

Project Proponent

- PG&E

Needs

- NERC Category B (G-1)
- Known current operational issue

Project Scope

- Reconductor 3 miles of line.

Costs

- \$1 to \$5 M

Other Considered Alternatives

- Build new line between Henrietta and Jacobs Corner

Expected In-Service

- May 2011

Recommended Action: Approval by CAISO Management

* Source: PG&E

(3) Herndon 115kV Circuit Breaker Replacement

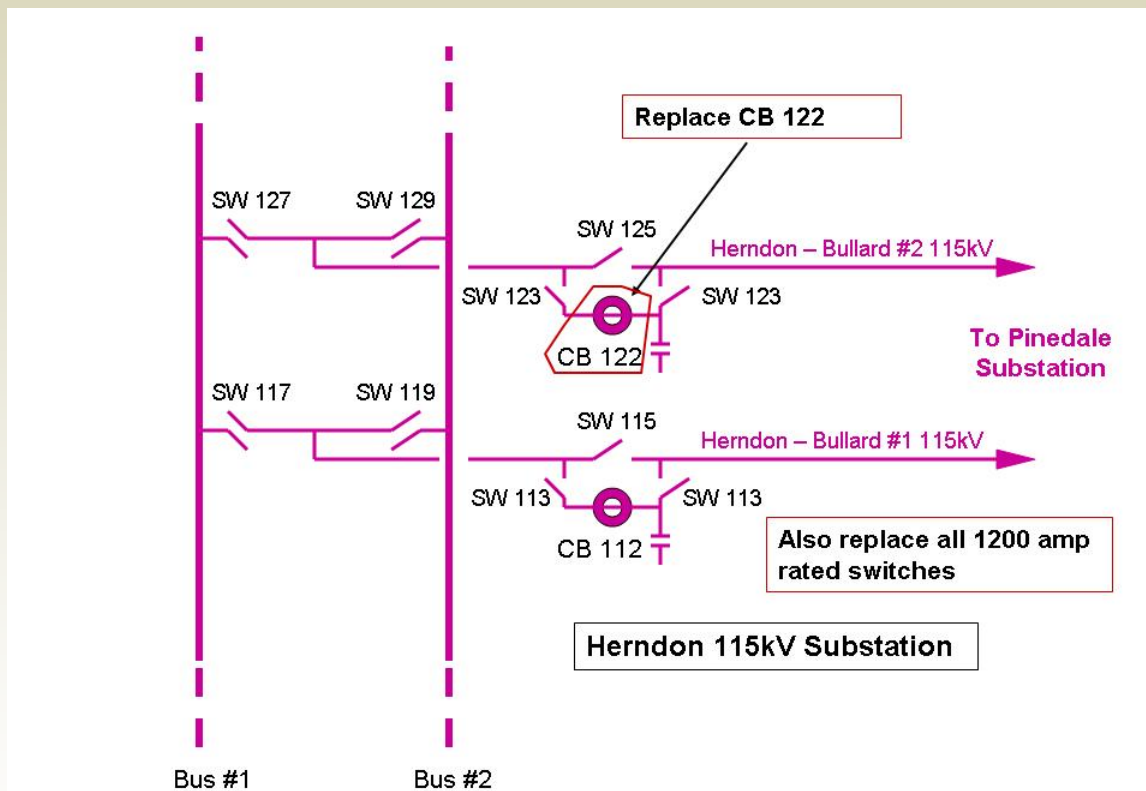

* Source: PG&E

Project Proponent

- PG&E

Needs

- NERC Category B (L-1)

Project Scope

- Replace CB 122 with a 2000 Amp CB .

Costs

-\$1 to \$5 M

Other Considered Alternatives

- Limited – Due to Scope

Expected In-Service

-May 2011

Recommended Action: Approval by CAISO Management

(5) Sanger – California Ave 70 kV to 115 kV Voltage Conversion

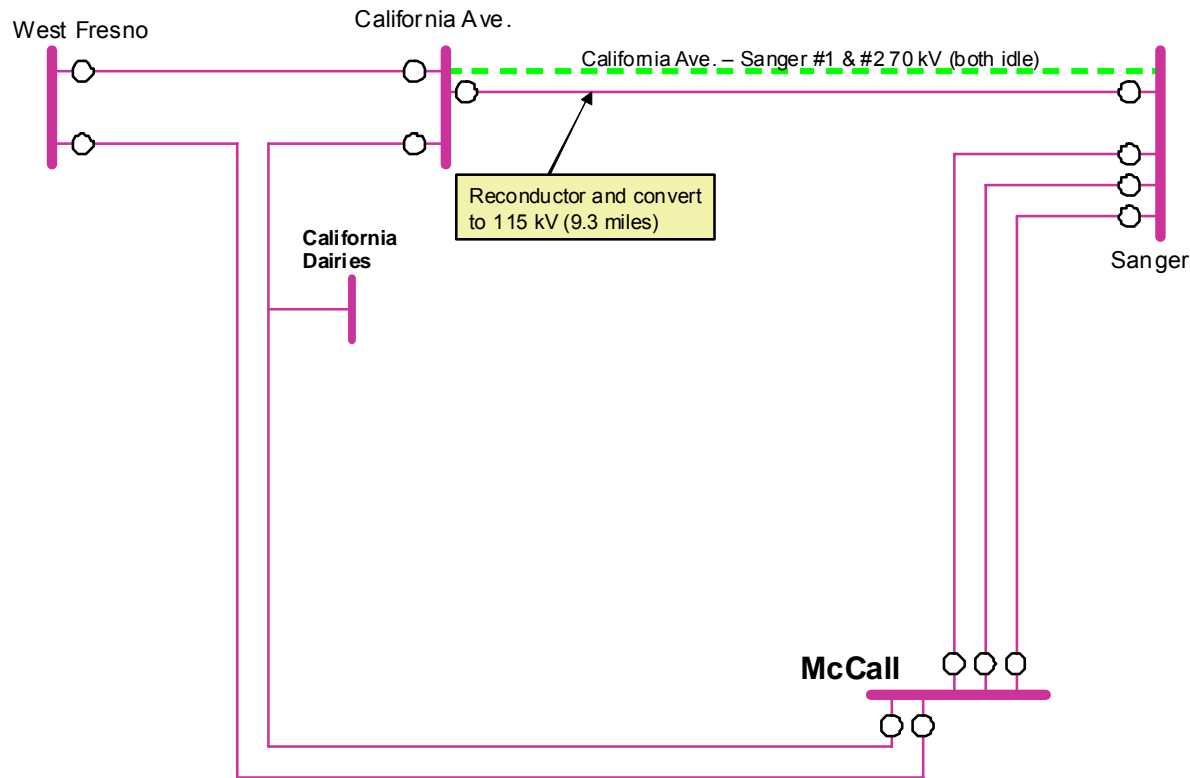

* Source: PG&E

Project Proponent

- PG&E

Needs

- NERC Category B (L-1)

Project Scope

- Convert Sanger – California 70 kV Line #2 for 115 kV operations

Costs

- \$5 to \$10 M

Expected In-Service

- May 2011

Other Considered Alternatives

- Install 75 MVars of shunt capacitors on the 115kV bus at West Fresno

Note

- Previously approved under title "West Fresno Support"

Recommended Action: Approval by CAISO Management

(6) Sanger – Reedley 70 kV to 115 kV Conversion

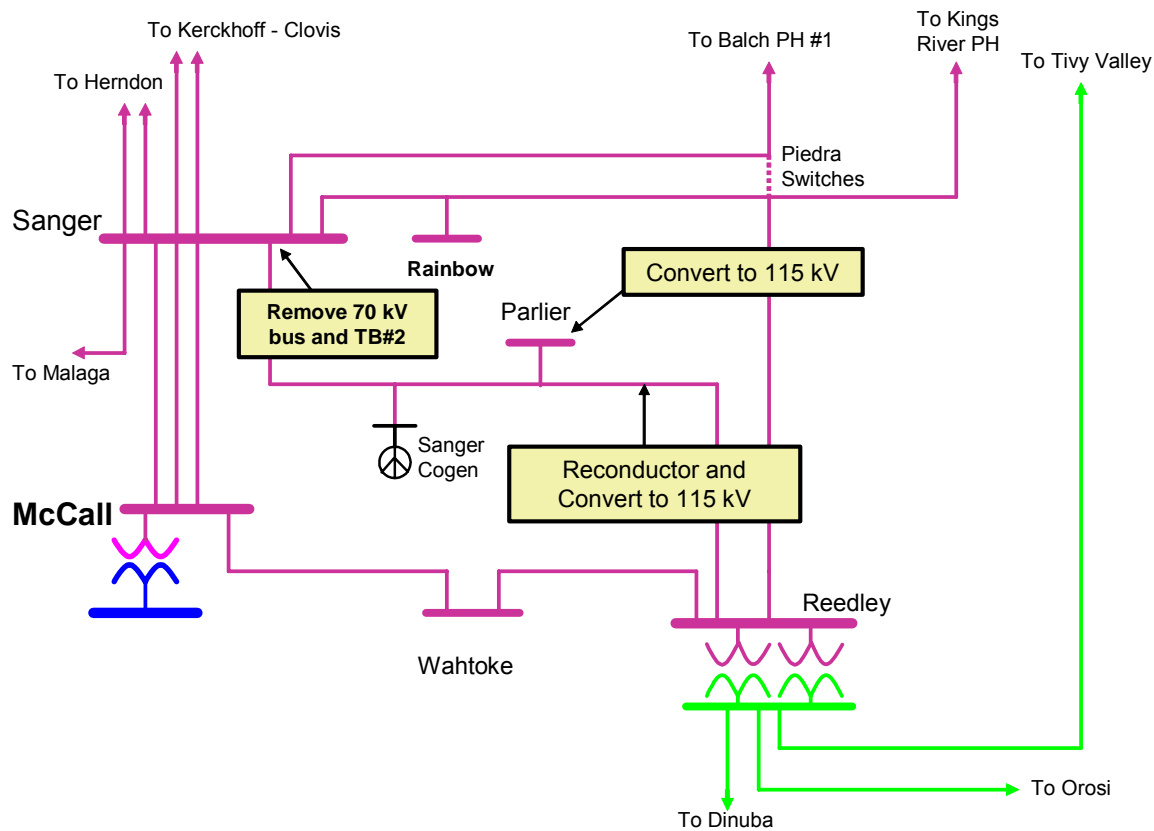

* Source: PG&E

Project Proponent

- PG&E

Needs

- NERC Category B (L-1)(G-1)

Project Scope

- Convert Sanger – Reedley 70 kV for 115 kV operation and reconnector line to carry minimum of 900 Amps under emergency conditions.

Costs

-\$20 to \$25 M

Other Considered Alternatives

- Reconnector the Sanger-Reedley 70 kV and Kings River-Sanger-Reedley 115 kV Lines
- Construct new line from McCall to Reedley

Expected In-Service

-May 2011

Recommended Action: Approval by CAISO Management

(7) Shepherd Substation Interconnection

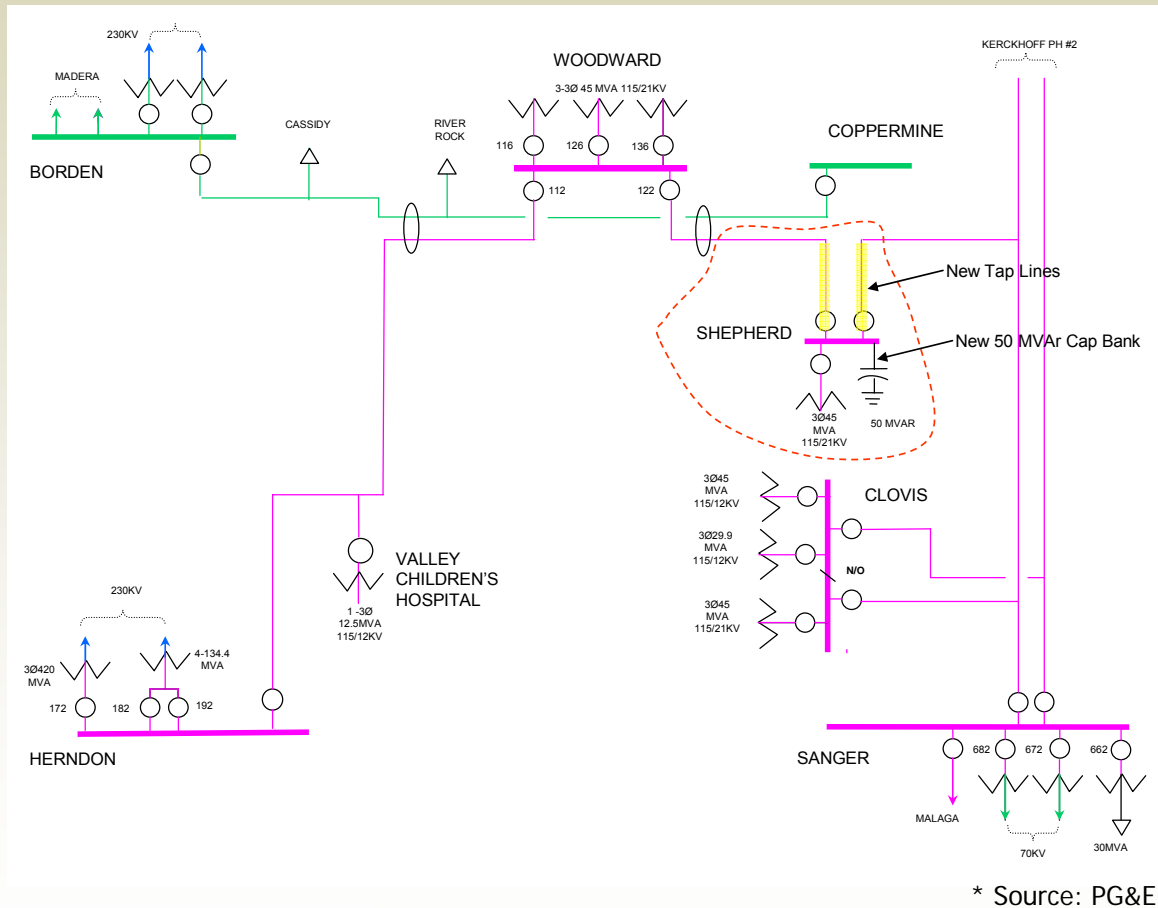

* Source: PG&E

Project Proponent

- PG&E

Needs

- No criteria violations
- Required for interconnection request

Project Scope

- Loop proposed Shepherd Substation off the Kerckhoff-Clovis-Sanger #1 115kV Line.
- Lines to carry a minimum capacity of 600 Amps for Summer Normal conditions and 1,355 Amps for summer emergency conditions.
- Designed to serve up to 45 MVA of distribution load
- Add additional 50 MVar of reactive support

Costs

-\$8 to \$10 M

Other Considered Alternatives

- Connect Shepherd sub via a Flip-Flop Scheme on Kerckhoff-Clovis-Sanger #1 and #2 115kV Lines
- Construct New Herndon-Woodward 115kV Line

Expected In-Service

-May 2011

Recommended Action: Approval by CAISO Management

Projects On-going or Denied

- Cressey-Gallo 115kV Line Project
- Wilson-Oro Loma 115kV Reconductor Project
- Ashlan-Gregg and Ashlan-Herndon 230kV Recondutor
- Los Banos-Oro Loma 70kV Area Reinforcement
- Oakhurst 115kV Tap Reinforcement
- E1 Substation
- Lemoore Area Reinforcement
- Corcoran-Guernsey Area Reinforcement
- Borden-Coppermine 70kV Upgrade
- Exchequer-Yosemite 70kV Reconductor
- West Fresno Interim Solution (Denied)
- Shepherd Interim Solution (Denied)



California ISO
Your Link to Power

10 Year Anniversary 1998-2008

Transmission Projects Seeking Approval San Joaquin Valley Area

Thank You!