

# 2013-2014 TRANSMISSION PLAN



**California ISO**  
Shaping a Renewed Future

March 25, 2014

Prepared by: Infrastructure Development  
Approved by: ISO Board of Governors

### **Forward to the Board-Approved 2013-2014 Transmission Plan**

At the March 20, 2014 ISO Board of Governors meeting, the ISO Board of Governors approved the 2013-2014 Transmission Plan with the exception of the Delaney-Colorado River 500 kV line, which was recommended for approval as an economically driven project. The ISO will conduct further assessment of the Delaney-Colorado River 500 kV line project and will report back to the Board after the additional assessment has been conducted. Changes to the final 2013-2014 Transmission Plan from the plan submitted to the Board for approval, have been noted with footnotes.

## Table of Contents

Executive Summary.....	1
Introduction .....	1
The Transmission Planning Process .....	3
Collaborative Planning Efforts .....	4
Reliability Assessment.....	6
Southern California Reliability Assessment (LA Basin and San Diego).....	8
Advancing Preferred Resources.....	8
33 Percent RPS Generation Portfolios and Transmission Assessment.....	9
Economic Studies.....	12
Conclusions and Recommendations .....	13
Chapter 1 .....	15
1 Overview of the Transmission Planning Process .....	15
1.1 Purpose .....	15
1.2 Structure of the Transmission Planning Process .....	16
1.2.1 Phase 1 .....	17
1.2.2 Phase 2.....	19
1.2.3 Phase 3.....	21
1.3 Generator Interconnection and Deliverability Allocation Procedures (GIDAP) .....	22
1.4 DG Deliverability .....	24
1.5 FERC Order No. 1000.....	25
1.6 Southern California Reliability Assessment .....	27
1.7 Renewable Integration Operational Studies .....	27
1.8 Non-Transmission Alternatives and Preferred Resources .....	28
1.9 Critical Energy Infrastructure Information (CEII) .....	30
1.10 Energy Imbalance Market .....	30
1.11 Coordination of Transmission Planning and Long Term Procurement Activities.....	31
Chapter 2 .....	33
2 Reliability Assessment – Study Assumptions, Methodology and Results.....	33
2.1 Overview of the ISO Reliability Assessment.....	33
2.1.1 Backbone (500 kV and selected 230 kV) System Assessment.....	33
2.1.2 Regional Area Assessments.....	33
2.2 Reliability Standards Compliance Criteria.....	34
2.2.1 NERC Reliability Standards.....	34

2.2.2	WECC Regional Criteria.....	35
2.2.3	California ISO Planning Standards .....	35
2.3	Study Methodology and Assumptions .....	35
2.3.1	Study Methodology.....	35
2.3.2	Study Assumptions.....	36
2.4	Northern California Bulk Transmission System Assessment .....	46
2.4.1	Northern California Bulk Transmission System Description .....	46
2.4.2	Study Assumptions and System Conditions .....	47
2.4.3	Assessment and Recommendations .....	50
2.5	PG&E Local Areas Assessment.....	52
2.5.1	Humboldt Area .....	52
2.5.2	North Coast and North Bay Areas .....	56
2.5.3	North Valley Area .....	61
2.5.4	Central Valley Area .....	64
2.5.5	Greater Bay Area .....	69
2.5.6	Greater Fresno Area .....	74
2.5.7	Kern Area.....	79
2.5.8	Central Coast and Los Padres Areas .....	86
2.6	Southern California Bulk Transmission System Assessment.....	90
2.6.1	Area Description.....	90
2.6.2	Area-Specific Assumptions and System Conditions .....	92
2.6.3	Assessment and Recommendations .....	95
2.7	SCE Local Areas Assessment.....	109
2.7.1	Tehachapi and Big Creek Corridor .....	109
2.7.2	Antelope-Bailey .....	112
2.7.3	North of Lugo Area .....	114
2.7.4	East of Lugo.....	117
2.7.5	Eastern Area .....	119
2.7.6	Los Angeles Metro Area.....	122
2.8	Valley Electric Association Local Area Assessment .....	129
2.8.1	Area Description.....	129
2.8.2	Area-Specific Assumptions and System Conditions .....	129
2.8.3	Assessment and Recommendations .....	130
2.9	San Diego Gas & Electric Local Area Assessment.....	131
2.9.1	Area Description.....	131
2.9.2	Area-Specific Assumptions and System Conditions .....	131
2.9.3	Assessments and Recommendations.....	135
Chapter 3.....		139
3	Special Reliability Studies and Results .....	139
3.1	Overview .....	139
3.2	Reliability Requirement for Resource Adequacy .....	139
3.2.1	Local Capacity Requirements.....	139
3.2.2	Resource Adequacy Import Capability.....	143
3.3	Review of Existing SPS.....	145

Chapter 4 ..... 151

4 Policy-Driven Need Assessment..... 151

4.1 Study Assumptions and Methodology ..... 151

4.1.1 33% RPS Portfolios ..... 151

4.1.2 Assessment Methods for Policy-Driven Transmission  
Planning ..... 155

4.1.3 Base Case Assumptions ..... 156

4.1.4 Power Flow and Stability Base Case Development ..... 157

4.1.5 Testing Deliverability for RPS ..... 158

4.2 Policy-Driven Assessment in Northern CA (PG&E Area)..... 162

4.2.1 PG&E Policy-Driven Powerflow and Stability Assessment  
Results and Mitigations ..... 163

4.2.2 Northern PG&E System Policy-Driven Deliverability  
Assessment Results and Mitigations ..... 180

4.2.3 Southern PG&E System Policy-Driven Deliverability  
Assessment Results and Mitigations ..... 182

4.2.4 PG&E Area Policy-Driven Conclusions..... 183

4.3 Policy-Driven Assessment in Southern California..... 186

4.3.1 Southern California Policy-Driven Powerflow and Stability  
Assessment Results and Mitigations ..... 189

4.3.2 SCE and VEA Area Policy-Driven Deliverability  
Assessment Results and Mitigations ..... 192

4.3.3 SDG&E Area Policy-Driven Deliverability Assessment  
Results and Mitigations ..... 200

4.3.4 Southern California Policy-Driven Conclusions..... 207

Chapter 5 ..... 209

5 Economic Planning Study..... 209

5.1 Introduction ..... 209

5.2 Study Steps..... 209

5.3 Technical Approach ..... 210

5.4 Tools and Database ..... 212

5.5 Study Assumptions ..... 214

5.5.1 System modeling..... 214

5.5.2 Load demand ..... 215

5.5.3 Generation resources..... 217

5.5.4 Transmission assumptions and modeling ..... 217

5.5.5 Financial Parameters Used in Cost-Benefit Analysis ..... 222

5.6 Congestion Identification and Scope of High Priority Studies ..... 224

5.6.1 Congestion identification ..... 224

5.6.2 Scope of high-priority studies ..... 226

5.7 Congestion Mitigation and Economic Assessment ..... 230

5.7.1 Midway – Vincent 500 kV line #4 ..... 231

5.7.2 Pacific Northwest – California (NWC) ..... 238

5.7.3 Harry Allen – Eldorado 500 kV line ..... 246

5.7.4 Delaney – Colorado River 500 kV line ..... 252

5.7.5	North Gila – Imperial Valley 500 kV line #2.....	268
5.8	Summary.....	274
Chapter 6.....		275
6	Other Studies and Results.....	275
6.1	Long-Term Congestion Revenue Rights Simultaneous Feasibility Test Studies .....	275
6.1.1	Objective .....	275
6.1.2	Data Preparation and Assumptions .....	275
6.1.3	Study Process, Data and Results Maintenance.....	276
6.1.4	Conclusions.....	276
Chapter 7 .....		277
7	Transmission Project List.....	277
7.1	Transmission Project Updates.....	277
7.2	Transmission Projects found to be needed in the 2013-2014 Planning Cycle .....	288
7.3	Competitive Solicitation for New Transmission Elements .....	292
7.4	Capital Program Impacts on Transmission High Voltage Access Charge.....	294
7.4.1	Background.....	294
7.4.2	Input Assumptions and Analysis.....	295
Appendix A	System Data	
Appendix B	Reliability Assessment	
Appendix C	Reliability Assessment Study Results	
Appendix D	San Francisco Peninsula Extreme Event Reliability Assessment	
Appendix E	2013 Request Window Submittals	
Appendix F	Description and Functional Specifications for Transmission Elements Eligible for Competitive Solicitation	

# Executive Summary

## Introduction

The 2013-2014 California Independent System Operator Corporation Transmission Plan provides a comprehensive evaluation of the ISO transmission grid to identify upgrades needed to successfully meet California's policy goals, in addition to examining conventional grid reliability requirements and projects that can bring economic benefits to consumers. This plan is updated annually, and is prepared in the larger context of supporting important energy and environmental policies while maintaining reliability through a resilient electric system.

In recent years, California enacted policies aimed at reducing greenhouse gases and increasing renewable resource development. The state's goal, to have renewable resources provide 33 percent of California's retail electricity consumption by 2020, has become the principal driver of substantial investment in new renewable generation capacity both inside and outside of California.

As well, the early retirement of the San Onofre Nuclear Generating Station coupled with the impacts of potential retirement of gas-fired generation in the San Diego and LA Basin areas – largely to eliminate coastal water use in “once-through cooling” have created both opportunities for development of preferred resources as well as challenges in ensuring continued reliable service in these areas.

The transmission plan describes the transmission necessary to meet the state's needs. Key analytic components of the plan include the following:

- continuing to refine the plans for transmission needed to support meeting the 33 percent RPS goals over a diverse range of renewable generation portfolio scenarios, which are based on plausible forecasts of the type and location of renewable resources in energy-rich areas most likely to be developed over the 10 year planning horizon;
- developing the necessary information to support advancement of preferred resources in meeting southern California needs, taking immediate steps regarding “least regrets” transmission that can contribute to the overall solution, and providing a framework for future consideration of additional transmission development;
- identifying transmission upgrades and additions needed to reliably operate the network and comply with applicable planning standards and reliability requirements; and
- performing economic analysis that considers whether transmission upgrades or additions could provide additional ratepayer benefits.

In addition, the identification of the roles non-transmission alternatives, particularly preferred resources and storage, can play where more than solely transmission reinforcement is required has also become a key focus of the transmission planning analysis that underpins the transmission planning efforts. In this regard, the ISO's transmission planning efforts focus on not only meeting the state's policy objectives in advancing policy-driven transmission, but also to help transform the electric grid in an environmentally responsible way. The focus on a cleaner

lower emission future governs not only policy-driven transmission, but our path on meeting other electric system needs as well.

Our comprehensive evaluation of the areas listed above resulted in the following key findings:

- the ISO identified 28 transmission projects with an estimated cost of approximately \$1.70 billion as needed to maintain transmission system reliability. Three of these mitigations were identified specifically to address reliability needs in the LA Basin and San Diego areas in light of the retirement of the SONGS generation coupled with the impacts of potential retirement of gas-fired generation in the San Diego and LA Basin areas;
- one service area, the San Francisco peninsula, has been identified by PG&E as being particularly vulnerable to lengthy outages in the event of extreme (NERC Category D) contingencies, and further research was undertaken in this planning cycle to determine the need and options for reinforcement. However, the ISO has determined that more analysis of the reliability risks and the benefits that potential reinforcement options would have in reducing those risks is needed. The ISO plans to undertake this analysis this year and may bring forward a recommendation for ISO Board approval as an addendum to this plan or in the next planning cycle as part of the 2014-15 Transmission Plan;
- consistent with recent transmission plans, no new major transmission projects have been identified at this time to support achievement of California's 33 percent renewables portfolio standard given the transmission projects already approved or progressing through the California Public Utilities Commission approval process. However;
  - 2 smaller policy-driven transmission upgrades have been identified in this transmission plan, which the ISO is recommending for approval in this plan;
  - the deliverability of future renewable generation from the Imperial Valley area may be significantly reduced primarily due to changes in flow patterns resulting from the retirement of the San Onofre Nuclear Generating Station. Despite the impacts being heavily offset by other reinforcements proposed in this transmission plan, only 1000 MW of the 1715 MW of Imperial zone renewable generation portfolio amounts can be made deliverable without additional actions. Given this significant change in circumstance, the ISO will conduct further study in the 2014-2015 transmission planning cycle to develop the most effective solution to achieve previously established target import capability levels.
- one economically driven 500 kV transmission project, the Delaney-Colorado River transmission project, is being recommended for approval;<sup>1</sup>
- one other economically driven project, a 500 kV transmission line from Eldorado to Harry Allen was found to provide significant potential benefits. However, due to recent announcements regarding the intention of NV Energy to join the ISO's energy imbalance market, the impact of this change on the benefits of the transmission project will need to

---

<sup>1</sup> The Delaney-Colorado River 500kV line was not approved by the ISO Board of Governors at the March 20, 2014 Board meeting.



be assessed before the ISO can make a recommendation on this project. The ISO intends to complete this review and bring the project forward for consideration at a future Board of Governors meeting; and

- the ISO tariff sets out a competitive solicitation process for reliability-driven, policy-driven and economically driven regional transmission facilities found to be needed in the plan.

We have identified seven<sup>2</sup> solutions containing facilities that are eligible for competitive solicitation in this transmission plan:

- Imperial Valley flow controller (if the back-to-back HVDC convertor is selected as the preferred technology)
- Estrella 230/70 kV substation
- Wheeler Ridge Junction 230/115 kV substation
- Suncrest 300 Mvar Dynamic Reactive Support
- Delaney-Colorado River project.<sup>3</sup>
- Spring 230/115 kV substation near Morgan Hill
- Miguel 500 kV Voltage Support

Also, the other areas identified for further study could also trigger additional needs that, if approved by the Board, could be eligible for competitive solicitation.

This year's transmission plan is based on the ISO's transmission planning process, which involved collaborating with the California Public Utilities Commission and many other interested stakeholders. Summaries of the transmission planning process and some of the key collaborative activities are provided below. This is followed by additional details on each of the key study areas and associated findings described above.

## The Transmission Planning Process

A core responsibility of the ISO is to plan and approve additions and upgrades to transmission infrastructure so that as conditions and requirements evolve over time, it can continue to provide a highly reliable and efficient bulk power system and well-functioning wholesale power market. Since it began operation in 1998, the ISO has fulfilled this responsibility through its annual transmission planning process. The State of California's adoption of new environmental policies and goals created a need for some important changes to the planning process. The ISO amended its tariff to address those needed changes, and the Federal Energy Regulatory Commission (FERC) approved the ISO tariff amendments on December 16, 2010. The amendments went into effect on December 20, 2010.

Those early changes provided a strong foundation for addressing the refinements driven in the regional components of FERC's Order 1000. On October 11, 2012, the ISO filed revisions to its

---

<sup>2</sup> There are only six solutions containing facilities that are eligible for competitive solicitation as the Delaney-Colorado River 500 kV line was not approved by the ISO Board of Governors at the March 20, 2014 ISO Board meeting.

<sup>3</sup> The Delaney-Colorado River 500 kV line was not approved by the ISO Board of Governors at the March 20, 2014 ISO Board meeting.

tariff to comply with the local and regional transmission and cost-allocation requirements of Order 1000. On April 18, 2013 FERC issued an order accepting the ISO's compliance filing, effective as of October 1, 2013, subject to a further compliance filing to clarify tariff provisions. The ISO made a supplemental compliance filing on August 20, 2013 that addressed such topics identified in the April 18 Order relating primarily to clarifications in the competitive solicitation process.

The ISO has also been implementing the integration of the transmission planning process with the generation interconnection procedures, based on the Generator Interconnection and Deliverability Allocation Procedures (GIDAP) approved by FERC in July 2012. The principal objectives of the GIDAP were to 1) ensure that, in the future, all major transmission additions and upgrades to be paid for by transmission ratepayers would be identified and approved under a single comprehensive process — the transmission planning process — rather than some projects coming through the transmission planning process and others through the generator interconnection process; 2) limit ratepayers' exposure to potentially costly interconnection-driven network upgrades that may not be most cost effective; and 3) enable the interconnection study process to determine meaningful network upgrade needs and associated cost estimates in a context where the volume of the interconnection queue vastly exceeds the amount of new generation that will actually be needed and built.

## **Collaborative Planning Efforts**

The ISO, utilities, state agencies and other stakeholders continue to work closely to assess how to meet the environmental mandates established by state policy. The collaboration with these entities is evident in the following initiatives.

### *State Agency Coordination in Planning*

State agency coordination in planning has taken significant steps forward in 2013 building further improvements that have impacted this year's plan as well as setting a stage for enhancements in future transmission planning cycles.

### *Preliminary Reliability Plan for LA Basin and San Diego:*

In response to the announced closure of the San Onofre Nuclear Generating Station on June 7, 2013, the staff of the California Public Utilities Commission, the California Energy Commission and ISO developed a Preliminary Reliability Plan for the LA Basin and San Diego area. The draft, released on August 30, 2013, was developed in consultation with SWRCB, SCE, SDG&E and South Coast Air Quality Management District (SCAQMD) and describes the coordinated actions the CPUC, CEC, and CAISO staff are pursuing in the near term (4 years) and the long-term (7 years). These actions collectively comprised a preliminary reliability plan to address the closure of San Onofre, the expected closure of 5,068 MW of gas-fired generation that uses once-through cooling technology, and the normal patterns of load-growth. The preliminary plan highlights the importance of beginning planning now to make sure regulatory actions are made in time to meet future electricity needs in the region.

The reliability plan also identified challenging goals that will need to be fully vetted in the public decision making processes of the appropriate agency, with a focus on ensuring reliability,

finding the most environmentally clean grid solutions, and urgently pursuing the variety of decisions that must ultimately be made and approved by key state agencies. The preliminary reliability plan contains the recommendations of CPUC, CEC and ISO. However, implementing the specific mitigation options discussed below will require decisions to be determined through CPUC or CEC proceedings, through the ISO planning process or both.

*Process and Planning Assumptions Alignment – and Single Set of Forecast Assumptions*

The ISO has worked collaboratively with the CPUC and the California Energy Commission (CEC) in 2013 to align the processes of future CPUC Long Term Procurement Planning processes, ISO transmission planning processes, and CEC Integrated Energy Policy Report proceedings.

Also, these agencies worked together to develop a “single managed forecast” to be used for the future local and system studies performed for both the transmission planning process and the LTPP process.

In addition to the single forecast set, the CPUC, CEC and ISO worked together to develop common planning assumptions and scenarios for the transmission planning process and the LTPP process. The assumptions utilize the single managed forecast as the basis for the demand side assumptions with common supply side assumptions developed taking into consideration the weather normalization for the different studies (local area, bulk, renewable portfolio and economic studies) and locational uncertainty for the Additional Achievable Energy Efficiency within the local area studies. Similarly, for the supply side, the assumptions are consistent and take into consideration the locational uncertainty of potential resources (i.e. demand response and storage) within the local area studies.

Based on the process alignment achieved to date and the progress on common planning assumptions, the ISO anticipates conducting future transmission planning process studies, 10-year Local Capacity Requirement studies, and system resource studies (including operational flexibility) during each transmission planning cycle, using the consistent planning assumptions established for both processes.

*Inter-regional Planning Requirements of FERC Order 1000*

In July 2011, FERC issued Order No. 1000 on “Transmission Planning and Cost Allocation by Transmission Owning and Operating Public Utilities.” The order required the ISO to make a filing demonstrating that the ISO is a qualified regional planning entity under the definition of the order, and modifying the ISO tariff as needed to meet the regional planning provisions of the order as noted earlier. It also required the ISO to develop and file common tariff provisions with each of its neighboring planning regions to define a process whereby each pair of adjacent regions can identify and jointly evaluate potential inter-regional transmission projects that meet their transmission needs more cost-effectively or efficiently than projects in their regional plans, and to specify how the costs of such a project would be assigned to the relevant regions that have selected the inter-regional project in their regional transmission plans.

The four planning regions reached agreement on a “Proposed Interregional Coordination Approach,” which was firmly grounded in Order 1000 principles and provided the framework for development of the tariff language that was ultimately proposed for inclusion placed in each

transmission utility provider's tariff. On May 10, 2013 the ISO, along with transmission utility providers belonging to the NTTG, and WestConnect planning regions jointly submitted their Order 1000 interregional compliance filings. The ColumbiaGrid transmission utility providers submitted the joint tariff language in June 2013 as part of the ColumbiaGrid interregional. The ISO considers these filings to be a significant achievement by all four planning regions and a reflection of their commitment to work towards a successful and robust interregional planning process under Order 1000. FERC orders on these initial filings have not been received and the provisions are therefore not yet in effect. The ISO and its neighbors are nonetheless undertaking coordination activities to the extent possible.

## Reliability Assessment

The reliability studies necessary to ensure compliance with North American Electric Reliability Corporation (NERC) and ISO planning standards are a foundational element of the transmission plan. During the 2012-2013 cycle, ISO staff performed a comprehensive assessment of the ISO controlled grid to ensure compliance with applicable NERC reliability standards. The analysis was performed across a 10-year planning horizon and modeled summer on-peak and off-peak system conditions. The ISO assessed transmission facilities across a voltage bandwidth of 60 kV to 500 kV, and where reliability concerns were identified, the ISO identified mitigation plans to address these concerns. These mitigation plans include upgrades to the transmission infrastructure, implementation of new operating procedures and installation of automatic special protection schemes. All ISO analysis, results and mitigation plans are documented in the transmission plan.

In total, this plan proposes approving 28 reliability-driven transmission projects, representing an investment of approximately \$1.70 billion in infrastructure additions to the ISO controlled grid. The majority of these projects (22) cost less than \$50 million and has a combined cost of \$409 million. The remaining six projects with costs greater than \$50 million have a combined cost of \$1.29 billion and consist of the following:

- **Mesa Loop-in** – Looping the Vincent-Mira Loma 500 kV transmission line into the existing Mesa Substation, and upgrading the substation to include a 500 kV bus.
- **Install Dynamic Reactive Support at San Luis Rey 230 kV Substation** – Adding synchronous condensers at the San Luis Rey Substation to provide voltage support to the transmission system in the San Onofre area.
- **Imperial Valley Flow Controller** – Installing a phase shifter or back-to-back HVDC flow control device on path to CFE.
- **Artesian 230 kV substation and loop-in** – Upgrading the existing Artesian substation to 230 kV to provide a new source into the 69 kV system.
- **Midway-Kern PP #2 230 kV line** – Reconductoring and unbundling the existing Midway-Kern PP 230 kV line into two circuits and looping one of the new circuits into the Bakersfield substation.

- **Wheeler Ridge Junction Station** – Building a new 230/115 kV substation at Wheeler Ridge Junction and converting the existing Wheeler Ridge-Lamont 115 kV to 230kV operation.

These reliability projects are necessary to ensure compliance with the NERC and ISO planning standards. A summary of the number of projects and associated total costs in each of the four major transmission owners' service territories is listed below in Table 1. Because Pacific Gas and Electric (PG&E) and San Diego Gas and Electric (SDG&E) have lower voltage transmission facilities (138 kV and below) under ISO operational control, a higher number of projects were identified mitigating reliability concerns in those utilities' areas, compared to the lower number for Southern California Edison (SCE).

Table 1 – Summary of Needed Reliability-Driven Transmission Projects in the ISO 2013-2014 Transmission Plan

Service Territory	Number of Projects	Cost (in millions)
Pacific Gas & Electric (PG&E)	14	\$486.4
Southern California Edison Co. (SCE)	2	\$626.0
San Diego Gas & Electric Co. (SDG&E)	11	\$584.0
Valley Electric Association (VEA)	1	0.1
Total	28	\$1,696.5

The majority of identified reliability concerns are related to facility overloads or low voltage. Therefore, many of the specific projects that comprise the totals in Table 1 include line reconductoring and facility upgrades for relieving overloading concerns, as well as installing voltage support devices for mitigating voltage concerns. Additionally, some projects involve building new load-serving substations to relieve identified loading concerns on existing transmission facilities. Several initially identified reliability concerns were mitigated with non-transmission solutions. These include generation redispatch and, for low probability contingencies, possible load curtailment.

One service area, the San Francisco peninsula, has been identified by PG&E as being particularly vulnerable to lengthy outages in the event of extreme (NERC Category D) contingencies, and further research was undertaken in this planning cycle to determine the need and options for reinforcement. However, the ISO has determined that further analysis of the reliability risks and the benefits that potential reinforcement options would have in reducing those risks is needed. The ISO plans to undertake this analysis this year and may bring forward a recommendation for ISO Board approval as an addendum to this plan or in the next planning cycle as part of the 2014-2015 Transmission Plan.

## **Southern California Reliability Assessment (LA Basin and San Diego)**

A major reliability focus of 2013-2014 transmission planning efforts has been the reliability needs in southern California – the LA Basin and San Diego area in particular – in light of the retirement of the SONGS generation coupled with the impacts of potential retirement of gas-fired generation in the San Diego and LA Basin areas.

As noted earlier, the ISO and state agency staff worked collaboratively to develop a preliminary draft plan, which helped frame the scope of the issues to be addressed and ensure coordinated action is being initiated in a number of fronts.

In this transmission plan, the ISO has accounted for the need for continued coordination and iterative dialogue with other state agency processes – the CPUC LTPP processes and CEC forecasting processes in particular, as well as the need to move decisively on “least regrets” transmission solutions that can play a significant role in addressing the local area challenges in the LA Basin and San Diego.

Additionally, the ISO has provided analysis of a number of preferred resource scenarios as well as a broad range of potential transmission solutions - using reduction in conventional generation needs as a measure of the potential benefits of these options. The analysis of preferred resource alternatives and storage alternatives will provide insight into utility procurement decisions.

The potential transmission solutions have been organized into three categories: 1) those optimizing existing transmission lines to address local area needs, 2) major new transmission that further reinforce the area and address reliability needs, and 3) major new transmission that would increase the import capability to the area and could potentially be coupled with other potential state policy objectives – such as promoting renewable energy development in certain areas of the state.

The ISO is recommending the first category of transmission solutions at this time, recognizing that there remains ample residual need for preferred resources and potentially other solutions, and margin for any reduction in local needs from future potential changes in load forecasts.

### **Advancing Preferred Resources**

In 2013, the ISO made material strides in facilitating use of preferred resources to meet local transmission system needs. Much of these efforts were foundational – future plans will build on these first steps.

The ISO developed a methodology for examining the operational characteristics that non-conventional resources (e.g., demand response, storage) would need to play an increased role in addressing local transmission system needs.

Within this planning cycle, much of the effort focused on coordinating this analysis of local area requirements with the utilities, and testing the specific preferred scenarios being developed by the utilities for the LA Basin and San Diego needs as discussed above, which required adapting the general methodology instead to meeting the specific study requirements in these areas where more comprehensive solutions were required.

This initiative also resulted in deferring of a number of local transmission reinforcements in the San Diego area as discussed in chapter 2.

### **33 Percent RPS Generation Portfolios and Transmission Assessment**

The transition to greater reliance on renewable generation has created significant transmission challenges because renewable resource areas tend to be located in places distant from population centers. The ISO's transmission planning process has balanced the need for certainty by generation developers as to where this transmission will be developed with the planning uncertainty of where resources are likely to develop by creating a structure for considering a range of plausible generation development scenarios and identifying transmission elements needed to meet the state's 2020 RPS. Commonly known as a least regrets methodology, the portfolio approach allows the ISO to consider resource areas (both in-state and out-of-state) where generation build-out is most likely to occur, evaluate the need for transmission to deliver energy to the grid from these areas, and identify any additional transmission upgrades that are needed under one or more portfolios. The ISO 33 percent RPS assessment is described in detail in chapters 4 and 5 of this plan.

In consultation with interested parties, CPUC staff developed three renewable generation scenarios for meeting the 33 percent RPS goal in 2020. The reduced number of scenarios from previous transmission planning cycles and less variability between several of the scenarios are indicative of less variability than in the past, as utilities move to complete their contracting for renewable resources to meet the 2020 goals, and there is more certainty about which areas resources will locate in.

In addition to transmission already approved by the ISO through the transmission planning process, the ISO considered Large Generator Interconnection Procedures (LGIP) network upgrades required to serve renewable resources that either have or were expected to have signed generator interconnection agreements.

The ISO assessment in this planning cycle did not identify at this time new major transmission projects to support achievement of California's 33 percent renewables portfolio standard given the transmission projects already approved or progressing through the California Public Utilities Commission approval process. Two smaller policy-driven transmission upgrades have been identified in this transmission plan, which the ISO is recommending for approval in this plan. The estimated cost of the two policy-driven projects is \$135 million.

However, the deliverability of future renewable generation from the Imperial Valley area has been significantly reduced primarily due to changes in flow patterns resulting from the retirement of the San Onofre Nuclear Generating Station. Despite the impacts being heavily offset by other reinforcements proposed in this transmission plan, only 1000 MW of the 1715 MW of Imperial zone renewable generation portfolio amounts can be made deliverable. The change will also impact the ability to maintain deliverability of import capability from the Imperial Irrigation District at the intended level of 1400 MW. Given this significant change in circumstance, the ISO will conduct further study in the 2014-2015 transmission planning cycle to develop the most effective solution to achieve previously established target import capability levels..

The additional policy-driven projects identified in this cycle are:

- a 300 Mvar SVC at Suncrest, and
- a Lugo-Mohave series capacitor and related terminal upgrades

Table 2 provides a summary of the various transmission elements of the 2012-2013 transmission plan for supporting California's RPS in addition to providing other reliability benefits. These elements are composed of the following categories:

- major transmission projects that have been previously approved by the ISO and are fully permitted by the CPUC for construction;
- additional transmission projects that the ISO interconnection studies have shown are needed for access to new renewable resources but are still progressing through the approval process; and
- major transmission projects that have been previously approved by the ISO but are not yet permitted.



Table 2: Elements of 2013-2014 ISO Transmission Plan Supporting Renewable Energy Goals

Transmission Facility	Online
Transmission Facilities Approved, Permitted and Under Construction	
Sunrise Powerlink (completed)	2012
Tehachapi Transmission Project	2015
Colorado River - Valley 500 kV line (completed)	2013
Eldorado – Ivanpah 230 kV line (completed)	2013
Carrizo Midway Reconductoring (completed)	2013
Additional Network Transmission Identified as Needed in ISO Interconnection Agreements but not Permitted	
Borden Gregg Reconductoring	2015
South of Contra Costa Reconductoring	2015
West of Devers Reconductoring	2019
Coolwater - Lugo 230 kV line	2018
Policy-Driven Transmission Elements Approved but not Permitted	
Mirage-Devers 230 kV reconductoring (Path 42)	2014
Imperial Valley Area Collector Station	2015
Sycamore – Penasquitos 230kV Line	2017
Lugo – Eldorado 500 kV Line Re-route	2015
Lugo – Eldorado series cap and terminal equipment upgrade	2016
Warnerville-Bellota 230 kV line reconductoring	2017
Wilson-Le Grand 115 kV line reconductoring	2020
Additional Policy-Driven Transmission Elements Recommend for Approval	
Suncrest 300 Mvar SVC	2017
Lugo-Mohave series capacitors	2016

## Economic Studies

Economic studies of transmission needs are another fundamental element of the ISO transmission plan. The objective of these studies is to identify transmission congestion and analyze if the congestion can be cost effectively mitigated by network upgrades. Generally speaking, transmission congestion increases consumer costs because it prevents lower priced electricity from serving load. Resolving congestion bottlenecks is cost effective when ratepayer savings are greater than the cost of the project. In such cases, the transmission upgrade can be justified as an economic project.

The ISO economic planning study was performed after evaluating all policy-driven transmission (i.e., meeting RPS) and reliability-driven transmission. Network upgrades determined by reliability and renewable studies were modeled as an input in the economic planning database to ensure that the economic-driven transmission needs are not redundant and are beyond the reliability- and policy-driven transmission needs. The engineering analysis behind the economic planning study was performed using a production simulation and traditional power flow software.

Grid congestion was identified using production simulation and congestion mitigation plans were evaluated through a cost-benefit analysis. Economic studies were performed in two steps: 1) congestion identification; and 2) congestion mitigation. In the congestion identification phase, grid congestion was simulated for 2018 (the 5th planning year) and 2023 (the 10th planning year). Congestion issues were identified and ranked by severity in terms of congestion hours and congestion costs. Based on these results, the five worst congestion issues were identified and ultimately selected as high-priority studies.

In the congestion mitigation phase, congestion mitigation plans were analyzed for the five worst congestion issues. In addition, two economic study requests were submitted. Based on previous studied, identified congestion in the simulation studies, and the study requests, the ISO identified 5 high priority studies, which were evaluated in the 2013-2014 planning cycle.

The analyses compared the cost of the mitigation plans to the expected reduction in production costs, congestion costs, transmission losses, capacity or other electric supply costs resulting from improved access to cost-efficient resources.

As in the 2012-2013 Transmission Plan, two projects in particular continued to demonstrate strong economic advantages – the Delaney-Colorado River 500 kV transmission line and the Harry Allen-Eldorado 500 kV transmission line. Both projects had been noted in the 2012-2013 Transmission Plan as needing further analysis.

Based on the continued analysis, the ISO is recommending proceeding with the Delaney-Colorado River<sup>4</sup> 500 kV transmission line. The estimated cost of this economic-driven project is \$338 million.

The ISO's analysis of the Harry Allen-Eldorado line continues to show potential benefits. However, given NV Energy's recent announcement of its intent to join the ISO's energy

---

<sup>4</sup> The Delaney-Colorado River 500 kV line was not approved by the ISO Board of Governors at the March 20, 2014 ISO Board meeting.

imbalance market, we do not consider it prudent to move forward on a recommendation until this market change can be properly reflected in an economic analysis. The ISO intends to conduct this analysis as continued study work as part of this 2013-2014 transmission planning cycle, or continue the analysis into the 2014-2015 planning cycle if necessary.

## Conclusions and Recommendations

The 2013-2014 ISO transmission plan provides a comprehensive evaluation of the ISO transmission grid to identify upgrades needed to adequately meet California's policy goals, address grid reliability requirements and bring economic benefits to consumers. This year's plan identified 31<sup>5</sup> transmission projects, estimated to cost a total of approximately \$2.17<sup>6</sup> billion, as needed to maintain the reliability of the ISO transmission system, meet the state's renewable energy mandate, and deliver material economic benefits.

The transmission plan also identified three subjects which require further study; the latter two may result in management seeking additional Board approvals of certain amendments to the 2013-2014 transmission plan at a future meeting:

- continuing the coordinated and iterative process of addressing southern California (LA Basin and San Diego area) needs with an emphasis on preferred resources, as well as resolving remaining technical decisions regarding recommended solutions that contribute to the overall need.
- addressing the potential need for transmission reinforcement of the San Francisco Peninsula due to outage concerns related to extreme contingencies,
- reviewing the economic benefits of an Eldorado-Harry Allen 500 kV transmission line addition, once existing study work can be updated to reflect NV Energy's intention to participate in the ISO's Energy Imbalance Market.

---

<sup>5</sup> The number of projects approved in the 2013-2014 Transmission Plan is 30 with the removal of the Delaney-Colorado River project, which was not approved by the ISO Board of Governors at the March 20, 2014 ISO Board meeting.

<sup>6</sup> The estimated total cost is approximately \$1.89 billion with the removal of the Delaney-Colorado River project, which was not approved by the ISO board of Governors at the March 20, 2014 ISO Board Meeting.

**Intentionally left blank**

## Chapter 1

# 1 Overview of the Transmission Planning Process

## 1.1 Purpose

A core ISO responsibility is to identify and plan the development of solutions to meet the future needs of the ISO controlled grid. Fulfilling this responsibility includes conducting an annual transmission planning process (TPP) that culminates in a Board approved, comprehensive transmission plan. The plan identifies needed transmission solutions and authorizes cost recovery through ISO transmission rates, subject to regulatory approval, as well as identifying other solutions that will be pursued in other venues to avoid additional transmission facilities if possible. The plan is prepared in the larger context of supporting important energy and environmental policies and assisting in the transition to a cleaner, lower emission future while maintaining reliability through a resilient electric system. This document serves as the comprehensive transmission plan for the 2013-2014 planning cycle.

The plan primarily identifies needed transmission facilities based upon three main categories of transmission solutions: reliability, public policy and economic needs. The plan may also include transmission solutions needed to maintain the feasibility of long-term congestion revenue rights, provide a funding mechanism for location-constrained generation projects or provide for merchant transmission projects.

The ISO identifies needed reliability solutions to ensure the transmission system performance is compliant with all North American Electric Reliability Corporation (NERC) standards and Western Electricity Coordinating Council (WECC) regional criteria as well as the ISO transmission planning standards. The reliability studies necessary to ensure such compliance comprise a foundational element of the transmission planning process. During the 2013-2014 cycle, ISO staff performed a comprehensive assessment of the ISO controlled grid to verify compliance with applicable NERC reliability standards. The analysis was performed across a 10-year planning horizon and it modeled summer on-peak and off-peak system conditions. The ISO assessed transmission facilities across a voltage range of 60 kV to 500 kV. The ISO also identified mitigation plans to address any observed concerns that included upgrading transmission infrastructure, implementing new operating procedures and installing automatic special protection schemes, and identifying the potential for conventional and non-conventional resources to meet these needs. In selecting recommended solutions for the identified needs, the ISO takes into account an array of considerations; furthering the state's objectives of transitioning to a cleaner future plays a major part in those considerations.

In the 2013-2014 planning cycle, the ISO placed considerable emphasis on assessing the characteristics necessary for non-conventional resources, such as demand response, to meet local area needs — focusing in particular on the Los Angeles basin and San Diego area requirements. The early retirement of the San Onofre Nuclear Generating Station coupled with the anticipated retirement of once-through-cooling gas fired generation has created a significant need, which the ISO anticipates will be met through a diverse set of resource options.

ISO analyses, results and mitigation plans are documented in this transmission plan.<sup>7</sup> These issues are discussed in more detail below.

Public policy-driven transmission solutions are those needed to enable the grid infrastructure to support state and federal directives. One such state directive is California law (SBX1-2) that requires 33 percent of the electricity sold annually in the state to be supplied from qualified renewable resources by the year 2020. Achieving this policy requires developing substantial amounts of renewable generating resources, along with building new infrastructure to deliver the power produced by these facilities to consumers. The 2010-2011 transmission planning cycle was the first to include a public policy-driven transmission category in recognition that the new transmission needed to support policies would unlikely qualify for approval based on the criteria defining other categories of transmission.

Economically driven solutions are those that offer economic benefits to consumers that exceed their costs as determined by ISO studies, which includes a production simulation analysis. Typical economic benefits include reductions in congestion costs and transmission line losses, as well as access to lower cost resources for the supply of energy and capacity.

## 1.2 Structure of the Transmission Planning Process

The annual planning process is structured in three consecutive phases with each planning cycle identified by a beginning year and a concluding year. Each annual cycle begins in January but extends beyond a single calendar year. The 2012-2013 planning cycle, for example, began in January 2012 and concluded in March 2013.

Phase 1 includes establishing the assumptions and models that will be used in the planning studies, developing and finalizing a study plan, and specifying the public policy mandates that planners will adopt as objectives in the current cycle. This phase takes roughly three months from January through March of the first year of the cycle.

Phase 2 is when the ISO performs studies to identify the needed solutions to the various needs that culminate in the annual comprehensive transmission plan. This phase takes approximately 12 months that ends with Board approval. Thus, phases 1 and 2 take 15 months to complete. The identification of non-transmission alternatives that are being relied upon in lieu of transmission solutions also takes place at this state. It is critical that parties responsible for approving or developing those non-transmission alternatives are aware of the reliance being placed on those alternatives.

---

<sup>7</sup> As part of efforts focused on the continuous improvement of the transmission plan document, the ISO has made several changes in the documentation of study results from prior years' plans. This document continues to provide detail of all study results necessary to transmission planning activities. However, consistent with the changes made in the 2012/2013 transmission plan, additional documentation necessary strictly for demonstration of compliance with NERC and WECC standards but not affecting the transmission plan itself is being removed from this year's transmission planning document and compiled in a separate document for future NERC/FERC audit purposes. In addition, detailed discussions of material that may constitute Critical Energy Infrastructure Information (CEII) are restricted to appendices that are shared only on the basis consistent with CEII requirements. High level discussions are provided in the publicly available portion of the transmission plan, however, to provide a meaningful overview of the comprehensive transmission system needs without compromising CEII requirements.

Phase 3 includes the competitive solicitation for prospective developers to build and own new transmission facilities identified in the Board-approved plan. In any given planning cycle, phase 3 may or may not be needed depending on whether the final plan includes transmission facilities that are open to competitive solicitation in accordance with criteria specified in the ISO tariff.

In addition, specific transmission planning studies necessary to support other state or industry informational requirements can be incorporated into the annual transmission planning process to efficiently provide study results that are consistent with the comprehensive transmission planning process. In this cycle, these studies focus primarily on continuing the review of the need and robustness of existing Special Protection Systems, as well as beginning the transition of incorporating renewable generation integration studies into the transmission planning process.

### **1.2.1 Phase 1**

Phase 1 generally consists of two parallel activities: 1) developing and completing the annual unified planning assumptions and study plan; and 2) developing a conceptual statewide transmission plan, which may be completed during phase 1 or phase 2. Improving upon the timelines and coordination achieved in the 2012-2013 planning cycle, the set of generating resource portfolios used to analyze public policy-driven transmission needs were developed as part of the unified planning assumptions in phase 1 for the 2013-2014 planning cycle. Further efforts are underway to again improve the level of coordination between both the policy-driven generating resource portfolios and other planning assumptions — in particular the load forecast and preferred resource forecasts, and these process improvements will continue in the 2014-2015 planning cycle.

The purpose of the unified planning assumptions is to establish a common set of assumptions for the reliability and other planning studies the ISO will perform in phase 2. The starting point for the assumptions is information and data derived from the comprehensive transmission plan developed during the prior planning cycle. The ISO adds other information, including network upgrades and additions identified in studies conducted under the ISO's generation interconnection procedures and incorporated in executed generator interconnection agreements (GIA). In the unified planning assumptions the ISO also specifies the public policy requirements and directives that will affect the need for new transmission infrastructure.

Public policy requirements and directives are an element of transmission planning that the ISO added to its planning process in 2010. Planning transmission to meet public policy directives was adopted by FERC as a national requirement under FERC's Order No. 1000. It enables the ISO to identify and approve transmission facilities that will be needed to enable the users of the ISO system to comply with state and federal requirements or directives. The primary policy directive for last three years' planning cycles and the current cycle is California's RPS that calls for 33 percent of the electric retail sales in the state in 2020 to be provided from eligible renewable resources. This requirement is continuing to drive substantial development of new renewable generating resources, which will require new transmission infrastructure to deliver their energy to consumers. As discussed later in this section, the ISO's study work and

determination of resource requirements for reliably integrating renewable resources is continuing on a parallel track outside of the transmission planning process, but first steps are taken in this transmission plan to begin to incorporate those requirements into annual transmission plan activities.

The study plan describes the computer models and methodologies to be used in each technical study, provides a list of the studies to be performed and the purpose of each study, and lays out a schedule for the stakeholder process throughout the entire planning cycle. The ISO posts the unified planning assumptions and study plan in draft form for stakeholder review and comment, during which stakeholders may request specific economic planning studies to assess the potential economic benefits (such as congestion relief) in specific areas of the grid. The ISO then specifies a list of high priority studies among these requests (i.e., those which the engineers expect may provide the greatest benefits) and includes them in the study plan when it publishes the final unified planning assumptions and study plan at the end of phase 1. The list of high priority studies may be modified later based on new information such as revised generation development assumptions and preliminary production cost simulation results.

The conceptual statewide transmission plan, also added to the planning process in 2010, was initiated based on the recognition that policy requirements or directives such as California's RPS apply throughout the state, not only within the ISO area. The conceptual statewide plan takes a whole-state perspective to identify potential upgrades or additions needed to meet state and federal policy requirements or directives such as renewable energy targets. Whenever possible, the ISO will perform this activity in coordination with regional planning groups and neighboring balancing authorities. For the previous planning cycles, the ISO has developed its conceptual statewide plan in coordination with other California planning authorities and load serving transmission providers under the structure of the California Transmission Planning Group (CTPG). Although the CTPG does not formally approve specific transmission projects for development, its members have performed important technical studies and issued a coordinated plan that provided specific project suggestions that each participating planning entity could consider for incorporation into its own transmission plan. CTPG activities have been largely placed on hold as planning entities have been focused on developing compliance filings addressing FERC Order 1000 requirements. The ISO therefore developed this year's conceptual state-wide plan by updating the previous plan using updated ISO information and publicly available information from our neighboring planning entities.

The ISO formulates the public policy-related resource portfolios in collaboration with the CPUC, with input from other state agencies such as the CEC and the municipal utilities within the ISO balancing authority area. The CPUC plays a primary role in the formulation of resource portfolios as the agency that oversees the supply procurement activities of the investor-owned utilities and the retail direct access providers, which collectively account for 95 percent of the energy consumed annually within the ISO area. The proposed portfolios are reviewed with stakeholders to seek their comments, which are then considered for incorporation into the final portfolios.

The resource portfolios play a crucial role in the identification of public policy-driven transmission elements, which is best illustrated by considering the RPS. Achieving the RPS will entail developing substantial amounts of new renewable generating capacity, which will in turn



require new transmission to deliver the renewable energy to consumers. At this time, however, there continues to be a great deal of uncertainty about which areas of the grid will actually realize most of this new resource development. The ISO must therefore plan new policy-driven transmission elements in a manner that recognizes this uncertainty and balances the requirement to have needed transmission completed and in service in time to meet the RPS by 2020 against the risk of building transmission in areas that do not realize enough new generation to justify the cost of such transmission. The planning process manages this uncertainty problem by applying a “least regrets” principle, which first formulates several alternative resource development portfolios or scenarios, then identifies the needed transmission to support each portfolio followed by selecting for approval those transmission elements that have a high likelihood of being needed and well-utilized under multiple scenarios. The least regrets approach is discussed further in the section on phase 2 below.

### **1.2.2 Phase 2**

In phase 2, the ISO performs all necessary technical studies, conducts a series of stakeholder meetings and develops an annual comprehensive transmission plan for the ISO controlled grid. The comprehensive transmission plan specifies the transmission solutions to system limitations needed to meet the infrastructure needs of the grid. This includes the reliability, public policy, and economically driven categories. In phase 2, the ISO conducts the following major activities:

1. performs technical planning studies as described in the phase 1 study plan and posts the study results;
2. provides a request window for submission of the following: reliability project proposals in response to the ISO’s technical studies, demand response storage or generation proposals offered as alternatives to transmission additions or upgrades to meet reliability needs, Location Constrained Resource Interconnection Facilities project proposals, and merchant transmission facility project proposals;
3. completes the conceptual statewide plan if it is not completed in phase 1, which is also used as an input during this phase, and provides stakeholders an opportunity to comment on that plan;
4. evaluates and refines the portion of the conceptual statewide plan that applies to the ISO system as part of the process to identify policy-driven transmission elements and other infrastructure needs that will be included in the ISO’s final comprehensive transmission plan;
5. coordinates transmission planning study work with renewable integration studies performed by the ISO for the CPUC long-term procurement proceeding to determine whether policy-driven transmission facilities are needed to integrate renewable generation, as described in tariff section 24.4.6.6(g);
6. reassesses, as needed, significant transmission facilities starting with the 2011-2012 planning cycle that were in GIP phase 2 cluster studies to determine — from a comprehensive planning perspective — whether any of these facilities should be

enhanced or otherwise modified to more effectively or efficiently meet overall planning needs;

7. performs a “least regrets” analysis of potential policy-driven solutions to identify those elements that should be approved as category 1 transmission elements,<sup>8</sup> which is based on balancing the two objectives of minimizing the risk of constructing under-utilized transmission capacity while ensuring that transmission needed to meet policy goals is built in a timely manner;
8. identifies additional category 2 policy-driven potential transmission facilities that may be needed to achieve the relevant policy requirements and directives, but for which final approval is dependent on future developments and should therefore be deferred for reconsideration in a later planning cycle;
9. performs economic studies, after the reliability projects and policy-driven solutions have been identified, to identify economically beneficial transmission solutions to be included in the final comprehensive transmission plan;
10. performs technical studies to assess the reliability impacts of new environmental policies such as new restrictions on the use of coastal and estuarine waters for power plant cooling, which is commonly referred to as once through cooling and AB 1318 legislative requirements for ISO studies on the electrical system reliability needs of the South Coast Air Basin;
11. conducts stakeholder meetings and provides public comment opportunities at key points during phase 2; and
12. consolidates the results of the above activities to formulate a final, annual comprehensive transmission plan to post in draft form for stakeholder review and comment at the end of January and present to the ISO Board for approval at the conclusion of phase 2 in March.

When the Board approves the comprehensive transmission plan at the end of phase 2, its approval will constitute a finding of need and an authorization to develop the reliability-driven facilities, category 1 policy-driven facilities and the economically driven facilities in the plan. The Board’s approval authorizes implementation and enables cost recovery through ISO transmission rates of those transmission projects included in the plan that require Board approval under current tariff provisions.<sup>9</sup> As indicated above, the ISO will solicit and accept

---

<sup>8</sup> In accordance with the least regrets principle, the transmission plan may designate both category 1 and category 2 policy-driven solutions. The use of these categories better enable the ISO to plan transmission to meet relevant state or federal policy objectives within the context of considerable uncertainty regarding which grid areas will ultimately realize the most new resource development and other key factors that materially affect the determination of what transmission is needed. The criteria to be used for this evaluation are identified in section 24.4.6.6 of the revised tariff.

<sup>9</sup> Under existing tariff provisions, ISO management can approve transmission projects with capital costs equal to or less than \$50 million. Such projects are included in the comprehensive plan as pre-approved by ISO management and not requiring further Board approval.

proposals in phase 3 from all interested project sponsors to build and own the transmission solutions that are open to competition.

By definition, the category 2 solutions in the comprehensive plan will not be authorized to proceed further when the ISO Board approves the plan, but will instead be identified for a re-evaluation of need during the next annual cycle of the planning process. At that time, based on relevant new information about the patterns of expected development, the ISO will determine whether the category 2 solutions now satisfy the least regrets criteria and should be elevated to category 1 status, should remain category 2 projects for another cycle, or should be removed from the transmission plan.

In the course of the 2012-2013 planning cycle, there was considerable additional industry emphasis placed on the potential for non-transmission alternatives to meet the needs that would otherwise necessitate transmission development, particularly energy efficiency and demand side management programs. Though the ISO cannot specifically approve non-transmission alternatives as projects or elements in the comprehensive plan, these can be identified as the preferred mitigation in the same manner that operational solutions are often selected in lieu of transmission upgrades. The ISO sought to increase public awareness of the opportunity to propose non-transmission alternatives for consideration in the phase 2 process, but received limited response. However, the 2012-2013 transmission plan did reveal the areas of greatest emerging need.

In this 2013-2014 planning cycle, the ISO has taken additional proactive steps in setting out and applying a methodology used in various targeted areas to assess the characteristics necessary for dispatchable resources, such as demand response, to play a larger role in meeting local system needs. It is expected that this information will help inform the acquisition of demand response amounts already approved by the CPUC, as well as encourage the development of additional resources in the future.

As noted earlier, phases 1 and 2 of the transmission planning process encompass a 15-month period. Thus, the last three months of phase 2 of one planning cycle will overlap phase 1 of the next cycle, which also spans three months. The ISO will conduct phase 3, the competitive solicitation for sponsors to build and own eligible transmission facilities of the final plan, following Board approval of the comprehensive plan and in parallel with the start of phase 2 of the next annual cycle.<sup>10</sup>

### **1.2.3 Phase 3**

Phase 3 will take place after the approval of the plan by the ISO Board, if projects eligible for competitive solicitation were approved by the Board in the draft plan at the end of phase 2. Projects eligible for competitive solicitation are reliability-driven, category 1 policy-driven or

---

<sup>10</sup> These details are set forth in the BPM for Transmission Planning.

economically driven elements, excluding projects that are modifications to existing facilities or local transmission facilities.<sup>11</sup>

If transmission solutions eligible for competitive solicitation are identified in phase 2 and approved, phase 3 will start in April of 2013 when the ISO will open a project submission window for the entities who propose to sponsor the identified transmission facilities. The ISO will then evaluate the proposals and, if there are multiple qualified project sponsors seeking to finance, build and own the same approved transmission facilities, the ISO will select the project sponsor by conducting a comparative evaluation using tariff selection criteria. Single proposed project sponsors who meet the qualification criteria can move forward to project permitting and siting.

### **1.3 Generator Interconnection and Deliverability Allocation Procedures (GIDAP)**

In July 2012 the ISO received FERC approval for the GIDAP, which represents a major revision to the existing generator interconnection procedures to better integrate those procedures with the transmission planning process. The GIDAP is being applied to generator interconnection requests submitted into queue cluster 5 in March 2012 and all subsequent queue clusters. Interconnection requests submitted into cluster 4 and earlier will continue to be subject to the provisions of the prior generation interconnection process (GIP).

The principal objective of the GIDAP was to ensure that going forward (beginning with queue cluster 5) all major transmission additions and upgrades to be paid for by transmission ratepayers would be identified and approved under a single comprehensive process — the transmission planning process — rather than some projects coming through the transmission planning process and others through the GIP. The GIDAP also limits ratepayers' exposure to potentially costly interconnection-driven network upgrades that may not be most cost effective, and enables the interconnection study process to determine meaningful network upgrade needs and associated cost estimates in the current context where the volume of the interconnection queue greatly exceeds the amount of new generation that will actually be needed and built.

The design of the GIDAP is based on the recognition that currently the biggest potential driver of costly interconnection network upgrades is the need to provide “deliverability status” to generating resources, which makes the resources eligible to provide resource adequacy capacity to load-serving entities within the ISO. The GIDAP design addresses this need by introducing a new planning objective into the transmission planning process: to provide

---

<sup>11</sup> The description of transmission solutions eligible for the competitive solicitation process was modified as part of the ISO's initial Order 1000 compliance filing. It was accepted by FERC in an April 18, 2013 order and became effective on October 1, 2013 as part of the 2013/2014 transmission planning process. Further tariff modifications were submitted on August 20, 2013 in response to the April 18, 2013 order and a final ruling has not yet been received on that submission. Section 1.5 below contains further information about Order 1000 and the ISO's compliance regional and interregional compliance filings.

deliverability status for new generating resources in a total amount and geographic distribution corresponding to the base case resource portfolio the ISO uses in the transmission planning process for purposes of identifying public policy-driven transmission solutions. In this way, the transmission planning process identifies any policy-driven upgrades needed to provide deliverability status to a generation portfolio that is consistent both in total volume and geographic distribution with how the state expects its LSEs to procure resources to meet their 33 percent RPS requirements. Once such upgrades are approved in the annual transmission planning process, the costs of these upgrades will be funded by ratepayers through the ISO Transmission Access Charge (TAC).

The transmission planning process identifies the need for large or “area” network upgrades that provide area-wide benefits by relieving deliverability constraints in areas of the ISO grid specified for generation development through the transmission planning process resource portfolios. An area deliverability constraint is a transmission system limit that would constrain the deliverability status of overall generation in an area to less than the amounts set out for that area in the resource portfolios developed for planning purposes. (Specific combinations of generation in the area may also drive the need for local delivery network upgrades, but those are developed through the GIP to align with the specific generators that proceed.) The ISO then determines the megawatt amount of “transmission plan deliverability” or “TPD” that is available in each area where the generation interconnection queue contains more generation than can be accommodated by the planned facilities.

Through the GIDAP, the ISO then allocates the resulting MW volumes of transmission plan deliverability to those proposed generating facilities in each area that are determined to be most viable based on a set of project development milestones specified in the tariff. Interconnection customers proposing generating facilities that are not allocated transmission plan deliverability but still want to build their projects and obtain deliverability status would be responsible for funding their needed delivery network upgrades at their own expense, without being eligible for cash reimbursement from ratepayers. This mechanism limits ratepayer exposure to excessive interconnection-driven upgrade costs, because generating facilities in excess of the volume of new generation the RPS portfolio requires or located in areas not included in the portfolio will not get the benefit of ratepayer-reimbursed delivery network upgrades.

In practical terms the impacts of the GIDAP are much greater to the generator interconnection rules and procedures than to the transmission planning process. The primary impact to the transmission planning process comes from including the planning objective of providing deliverability status to the base case 33 percent RPS generation portfolio. This requires the ISO planners to perform additional deliverability studies within the transmission planning process, which in turn may result in the transmission planning process identifying and including in the annual comprehensive transmission plan some public policy-driven transmission solutions that otherwise would have been identified and approved under the GIP.

The ISO recognizes that transmission-connected energy storage projects will likely require many of the same considerations as generation projects, including deliverability, and will be investigating means to streamline their participation in the interconnection process.

## Transmission Plan Deliverability

As set out in Appendix DD (GIDAP) of the ISO's, tariff, the available transmission plan deliverability is calculated in each year's transmission planning process in areas where the amount of generation in the ISO interconnection queue is greater than the available deliverability, as identified in the generator interconnection cluster studies. In areas where the amount of generation in the ISO interconnection queue is less than the available deliverability, the TPD is sufficient. In this year's transmission planning process, the ISO's generator interconnection queue was considered up to and including queue cluster 6.

### 1.4 DG Deliverability

The ISO worked with stakeholders during 2012 to develop a streamlined, annual process for providing resource adequacy (RA) deliverability status to distributed generation resources from transmission capacity identified in the ISO's annual transmission plan. The proposal was approved by the ISO Board in May 2012 and filed with FERC in September. The FERC issued an order in November conditionally accepting the ISO's proposed tariff revisions subject to the submission of a compliance filing modifying the ISO's proposal. The ISO then conducted a stakeholder initiative to develop the preferred compliance approach and made the compliance filing in April 2013, and completed the first cycle of the new process in time to qualify additional distributed generation resources to provide RA capacity for the 2014 RA compliance year.

Under the new process, the ISO annually performs two sequential steps. The first step is a deliverability study, which is performed within the context of the transmission planning process, to determine nodal MW quantities of deliverability status that can be assigned to DG resources. The second step is an apportionment of these quantities to utility distribution companies — including both the investor-owned and publicly-owned distribution utilities within the ISO controlled grid — who then assign deliverability status, in accordance with ISO tariff provisions, to eligible distributed generation resources interconnected or in the process of interconnecting to their distribution facilities.

In the first step of the process, the transmission planning process performs the DG deliverability study to identify available transmission capacity at specific grid nodes to support deliverability status for distributed generation resources without requiring any additional delivery network upgrades to the ISO controlled grid and without adversely affecting the deliverability status of existing generation resources or proposed generation in the interconnection queue. In constructing the network model to be used in the DG deliverability study, the ISO models the existing transmission system plus new additions and upgrades that have been approved in prior transmission planning process cycles, plus existing generation and certain new generation in the ISO interconnection queue and associated upgrades. This ensures that the nodal quantities of DG deliverability that result from the study can be made available without triggering additional delivery network upgrades or allowing some distributed generators to “queue jump” by utilizing available transmission capacity ahead of other generation projects earlier in the ISO or a utility's wholesale distribution access tariff (WDAT) queue. The DG deliverability study will use the nodal DG quantities that were specified in the base case resource portfolio that was adopted in the latest transmission planning process cycle for identifying public policy-driven transmission

needs, both as a minimal target level for assessing DG deliverability at each network node and as a maximum amount that can be used by distribution utilities for assigning deliverability status to generators in the current cycle. This will ensure that the DG deliverability assessment is aligned with the public policy objectives addressed in the current transmission planning process cycle and precludes the possibility of apportioning more DG deliverability in each cycle than was assumed in the base case resource portfolio used in the transmission planning process.

In the second step of the process, the ISO will specify how much of the identified DG deliverability at each node is available to the utility distribution companies that operate distribution facilities and interconnect distributed generation resources below that node. FERC's November 2012 order on the original proposal stipulated that FERC-jurisdictional entities must assign deliverability status to DG resources on a first-come-first-served basis, in accordance with the relevant interconnection queue. In compliance with this requirement, the ISO tariff specifies the process whereby the investor-owned utility distribution companies must establish the first-come-first-served sequence for assigning deliverability status to eligible distributed generation resources.

The ISO determined in the first cycle of the new DG deliverability process during 2013 that 892.45 MW of deliverability status could be assigned to DG resources in the SCE territory, including the publicly-owned distribution utilities within SCE's system, of which 158.33 MW were actually assigned to eligible DG resources. The ISO also found that 517.61 MW could be assigned to DG resources in the PG&E territory, including the publicly-owned distribution utilities within that system, of which 9.54 MW were assigned to eligible DG resources. There was no available DG deliverability within the SDG&E territory. Available MW of DG deliverability that have not yet been assigned to DG resources will remain available for the distribution utilities to assign during 2014, up until the fourth quarter of 2014 when the ISO begins the DG deliverability study for the 2015 cycle of the DG deliverability process.

Although this new DG deliverability process is performed as part of and in alignment with the annual transmission planning process cycle, its only direct impact on the transmission planning process is the addition of the DG deliverability study to be performed in the latter part of Phase 2 of the transmission planning process.

## 1.5 FERC Order No. 1000

The FERC issued its final rule in July 2011 on Order No. 1000 (Order 1000).<sup>12</sup> Order 1000 adopted reforms to the electric transmission planning and cost allocation requirements for public utility transmission providers that were established through Order No. 890 (Order 890).

The additional reforms required by Order 1000 affected the ISO's existing regional process as well as directing the ISO to collaborate with neighboring transmission utility providers and planning regions across the Western Interconnection to develop a coordinated process for considering interregional projects. These regional and interregional reforms were designed to

---

<sup>12</sup> Transmission Planning and Cost Allocation by Transmission Owning and Operating Public Utilities.\*\*\* citation

work together to ensure an opportunity for more transmission projects to be considered in transmission planning processes on an open and non-discriminatory basis both within planning regions and across multiple planning regions.

### Regional Tariff

The ISO developed during 2012 its regional proposal and revised tariff language required to meet its regional obligation under Order 1000. On October 11, 2012 the ISO filed revisions to its tariff to comply with the local and regional transmission and cost-allocation requirements of Order 1000. FERC issued an order on April 18, 2013 accepting the ISO's compliance filing, effective as of October 1, 2013, subject to a further compliance filing to clarify tariff provisions. The ISO made a supplemental compliance filing on August 20, 2013 that addressed such topics identified in the April 18 Order as the following: 1) adding additional details about the qualification and comparative selection information requirements; 2) establishing steps for notifying project sponsors of deficient applications and qualification deficiencies and providing an opportunity to cure deficiencies; 3) adding language further clarifying the development of key selection criteria for each solution subject to competitive solicitation; and 4) eliminating the existing tariff requirement that, when all project sponsors selected the same environmental siting agency, the siting agency would select the approved project sponsor. With the proposed tariff modification, the ISO will assume that responsibility.

### Interregional Tariff

The ISO worked with its stakeholders and neighboring planning regions to develop potential Order 1000 interregional compliance proposals starting in early 2013. Through this joint effort the planning regions developed processes for interregional transmission planning coordination and a methodology for allocating the costs of interregional transmission projects among the planning regions who identify such projects in their regional transmission plans. While Order 1000 only required, at a minimum, that pairs of regional planning entities work together to develop the tariff language describing interregional transmission coordination procedures, the ISO collaborated with three neighboring planning regions — West Connect, Columbia Grid and Northern Tier Transmission Group (NTTG) — to develop a single set of common policies and procedures for all four planning regions.

The four planning regions reached agreement on a "Proposed Interregional Coordination Approach," which was firmly grounded in Order 1000 principles and provided the framework for development of the tariff language that was ultimately proposed for inclusion placed in each transmission utility provider's tariff. The ISO, along with transmission utility providers belonging to the NTTG and WestConnect planning regions jointly submitted on May 10, 2013 their Order 1000 interregional compliance filings. The ColumbiaGrid transmission utility providers submitted their joint tariff language in June 2013. The ISO considers these filings to be a significant achievement by all four planning regions and a reflection of their commitment to work towards a successful and robust interregional planning process under Order 1000. FERC orders on these initial filings have not been received and the provisions are, therefore, not yet in effect. The ISO and its neighbors will continue to explore coordination efforts, however, to the extent they are achievable.



## 1.6 Southern California Reliability Assessment

As noted earlier, a major reliability focus of 2013-2014 transmission planning efforts has been the reliability needs in Southern California — the LA Basin and San Diego areas in particular — in light of the retirement of the SONGS generation coupled with the impacts of potential retirement of gas-fired generation in the San Diego and LA Basin areas.

The ISO and state agency staff worked collaboratively to develop a preliminary draft plan, which helped frame the scope of the issues to be addressed and ensure coordinated action is being initiated in a number of fronts. This approach focused on achieving reliability while transitioning to a cleaner, lower emission future; it inherently accepted that a range of mitigations would be required in the face of the scope of issues to be addressed in the area in which preferred resources, transmission, and some level of conventional generation would all be needed.

In this transmission plan, the ISO has accounted for the need for continued coordination and iterative dialogue with other state agency processes — the CPUC LTPP processes and CEC forecasting processes in particular — as well as the need to move decisively on least regrets transmission solutions that can play a significant role in addressing the local area challenges in the LA Basin and San Diego areas.

The ISO has provided analysis of a number of preferred resource scenarios as well as a broad range of potential transmission solutions. A scenario relying on conventional generation was also developed for comparative purposes — using conventional generation as the measuring stick against which other solutions were evaluated.

The analysis of preferred resource alternatives and storage alternatives demonstrate the effectiveness of the various resource mixes and will provide insight into future procurement decisions.

The potential transmission solutions have been categorizing into the following groups:

- those optimizing existing transmission lines to address local area needs;
- new transmission that further reinforce the area and address reliability needs; and
- those that provide reliability benefits but also could play a role in future state policy objectives.

The ISO is recommending the least regrets transmission solutions at this time and recognizing that there remains ample residual need for additional preferred resources and potentially other solutions, and for flexibility for future potential changes in load forecasts.

## 1.7 Renewable Integration Operational Studies

The ISO conducts a range of studies to support the integration of renewable generation on to the transmission grid, including planning for renewable generation portfolios (Chapter 4), generation interconnection process studies conducted outside of the transmission planning process but now more strongly coordinated with the transmission planning process, and renewable integration operational studies which have also been conducted outside of the transmission planning process.

Renewable integration operational studies have focused in particular on the need for flexible resource capabilities. In the CPUC 2010-2011 LTPP proceeding, docket R.10-05-006, the ISO completed an initial study of renewable integration requirements under a range of future scenarios. This work identified in the trajectory scenario up to 4,600 MW of additional flexible resource capacity could be required beyond the projected existing fleet in 2020 after factoring in approved new generation and OTC retirements, but not taking into account local capacity requirements in transmission constrained areas.

In the 2012-2013 Transmission Plan, the ISO indicated the intention to include in this 2013-2014 Transmission Plan the results of additional and updated renewable integration operational studies that were being conducted for the 2012-2013 LTPP proceeding. The track of that proceeding dealing with flexible resource requirements was cancelled, however, in favor of more broadly coordinated analysis planned for the 2014-2015 LTPP proceeding. In light of this, the ISO intends to summarize those flexibility studies in next year's 2014-2015 Transmission Plan.

In addition to the flexible resource studies, the ISO will also conduct studies regarding the potential for over generation conditions resulting from the addition of renewable generation to meet the 33 percent RPS. The ISO will be including the scope for those additional studies in the draft Unified Planning Assumptions and Study Plan for the 2014-2015 transmission planning process.

## 1.8 Non-Transmission Alternatives and Preferred Resources

The ISO made material strides in facilitating use of preferred resources to meet local transmission system needs. Much of these efforts were foundational – future plans will build on these first steps.

The ISO issued a paper<sup>13</sup> on September 4, 2013, as part of the 2013-2014 transmission planning cycle in which it presented a methodology to support California's policy emphasis on the use of preferred resources<sup>14</sup> – energy efficiency, demand response, renewable generating resources and energy storage – by considering how such resources can constitute non-conventional solutions to meet local area needs that otherwise would require new transmission or conventional generation infrastructure. In addition to developing a methodology to be applied annually in each transmission planning cycle, the paper also described how the ISO would apply the proposed methodology in future transmission planning cycles.

The general application for this methodology is in grid area situations where a non-conventional alternative, such as demand response or some mix of preferred resources could be selected as the preferred solution in the ISO's transmission plan rather than the conventional transmission

---

<sup>13</sup> <http://www.caiso.com/Documents/Paper-Non-ConventionalAlternatives-2013-2014TransmissionPlanningProcess.pdf>

<sup>14</sup> To be precise, "preferred resources" as defined in CPUC proceedings applies more specifically to demand response and energy efficiency, with renewable generation and combined heat and power being next in the loading order. The term is used more generally here consistent with the more general use of the resources sought ahead of conventional generation.

or generation solution. This would be possible in situations where the timeline for an identified need allows time for monitoring the development of non-conventional alternatives before a conventional solution would be required to be approved. For a grid area where the ISO finds a non-conventional solution to be effective, this new approach will result in a validated non-conventional resource mix that would be selected as the preferred solution in the ISO's transmission plan along with the transmission or conventional generation solution that would be avoided or deferred by implementing the non-conventional solution. Once the comprehensive transmission plan, is approved by the ISO Governing Board, which includes identification of both the non-conventional solution and the transmission or conventional generation solution that could be avoided or deferred the ISO would monitor the development of the resources that comprise the non-conventional solution to determine whether they will be in operation by the time they are needed. If the ISO determines that the non-conventional resource mix is not developing in a timely manner, then the ISO would consider whether to reinstate the avoided transmission solution or another appropriate alternative in a subsequent planning cycle.

Within the 2013-2014 transmission planning cycle, the ISO adapted this new approach in principle to several specific local areas in Southern California to meet the specific study requirements of those areas: the LA Basin and San Diego areas. Because of the magnitude of the projected reliability needs in these areas incremental transmission options were also studied to complement non-conventional alternatives (i.e., preferred resources) to reduce the need for conventional generation to fill the gap. Thus, unlike the generic application of the methodology in future transmission planning process cycles where preferred resources are considered as an alternative to transmission, the main focus of this effort with respect to the LA Basin and San Diego areas was to evaluate non-conventional alternatives and identify performance attributes needed from these alternatives that could effectively address the local reliability needs in these two priority areas as part of a basket of resources.

As the ISO's work in this area evolved in determining the necessary attributes, it received several sets of preferred resource development scenario input data from Southern California Edison for the LA Basin.<sup>15</sup> The ISO supplemented this stakeholder input with scenario assumptions for San Diego and with the system-connected distributed generation information provided by the CPUC as part of the 2013-2014 transmission planning process renewable portfolios (e.g., Commercial Interest portfolio). Selecting the input data that aligned with the ISO's view of the necessary performance attributes, several scenarios were developed and used as the basis for creating sensitivity power system models starting from the base power system models prepared for the 2013-2014 transmission planning process. These sensitivity power system models were then evaluated to determine the remaining transmission or conventional infrastructure improvements required, for comparison to the identified needs determined from the base power system models. The results of this analysis are documented in Chapter 2.

The ISO also received a number of energy storage proposals as potential mitigations of identified reliability needs. In the course of reviewing those energy storage projects — both

---

<sup>15</sup> No other stakeholders provided preferred resource scenario input data for consideration by the ISO.

battery and pumped hydro — proposed in this planning cycle as mitigations to reliability needs, the ISO developed a further appreciation for considerations that will need to be refined in future planning cycles. These projects were proposed as rate-based transmission assets, as opposed to market assets providing local resource capacity to utilities, and as such, are precluded from other market participation. While we could not recommend approval of these projects in this cycle for other reasons, we believe energy storage projects have significant potential for addressing renewable integration needs and plan to evaluate this potential in future cycles as well as potential barriers to achieving this potential.

## 1.9 Critical Energy Infrastructure Information (CEII)

The ISO protects CEII as set out in the ISO's tariff.<sup>16</sup> Release of this information also follows tariff requirements. In the course of the ISO's 2013-2014 transmission planning cycle, it determined that out of an abundance of caution on this sensitive area, additional measures should be taken to protect CEII information. Accordingly, the ISO has placed more sensitive detailed discussions of system needs into appendices that are not released through the ISO's public website. Rather, this information can be accessed through the ISO's market participant portal after the appropriate nondisclosure agreements are in place.

## 1.10 Energy Imbalance Market

The Energy Imbalance Market (EIM) will allow balancing authorities throughout the West to voluntarily participate in a real-time imbalance energy market operated by the ISO. The EIM will optimally dispatch resources within the ISO and EIM balancing authority areas footprint to meet the combined real-time imbalance needs of both regions in the most cost effective manner. The EIM will be part of the ISO's real-time market and leverages FERC Order No. 764 market design changes approved by the Board of Governors in May 2013. As such, the EIM will include a fifteen minute market and five minute dispatch across the combined network of the ISO and EIM balancing authorities.

Based upon PacifiCorp's interest in joining the EIM, a memorandum of understanding was developed with PacifiCorp early in 2013. The Board of Governors approved in March 2013 moving forward with the PacifiCorp implementation with a go-live date of October 1, 2014. The agreement was approved by FERC on June 28, 2013. The Board of Governors approved the EIM design in November 2013. The economic evaluation studies conducted in this planning cycle reflect the anticipated implementation.

---

<sup>16</sup> CAISO tariff Section 20 addresses how the ISO shares Critical Energy Infrastructure Information (CEII) related to the transmission planning process with stakeholders who are eligible to receive such information. The tariff definition of CEII is consistent with the meaning given the term in FERC regulations at 18 C.F.R. Section 388.113, *et. seq.* According to the tariff, eligible stakeholders seeking access to CEII must sign a non-disclosure agreement and follow the other steps described on the CAISO website.

NV Energy announced at the ISO Board of Governor meeting on November 13 that upon completing ongoing studies, it intends to seek approval to join the EIM from the Public Utilities Commission of Nevada. The ISO anticipates that the go-live date would be no earlier than fall 2015. The economic studies prepared in this planning cycle do not yet reflect NV Energy participation in the EIM.

### **1.11 Coordination of Transmission Planning and Long Term Procurement Activities**

The ISO has worked collaboratively with the CPUC and the California Energy Commission (CEC) in 2013 to align the processes of future CPUC long term procurement planning processes, ISO transmission planning processes, and CEC Integrated Energy Policy Report proceedings.

Also, these agencies worked together to develop a “single managed forecast” to be used for the future local and system studies performed for both the transmission planning process and the LTPP proceedings.

In addition to the single forecast set, the CPUC, CEC and ISO worked together to develop common planning assumptions and scenarios for the transmission planning process and the LTPP process. The assumptions used the single managed forecast as the basis for the demand side assumptions with common supply side assumptions developed taking into consideration the weather normalization for the different studies (local area, bulk, renewable portfolio and economic studies) and locational uncertainty for additional achievable energy efficiency savings within the local area studies. Similarly, for the supply side, the assumptions are consistent and take into consideration the locational uncertainty of potential resources (such as demand response and storage) within the local area studies.

Based on the process alignment achieved to date and the progress on common planning assumptions, the ISO anticipates conducting future transmission planning process studies, 10-year local capacity requirement studies, and system resource studies (including operational flexibility) during each transmission planning cycle, using the consistent planning assumptions established for both processes. This will enable the local and system needs to be set out in the August and September 2014 time frame and feed into the CPUC’s 2014-2015 LTPP proceeding. It also allows the ISO to document all of its results in the comprehensive 2014-2015 Transmission Plan by March of 2015.

**Intentionally left blank**

## Chapter 2

# 2 Reliability Assessment – Study Assumptions, Methodology and Results

### 2.1 Overview of the ISO Reliability Assessment

The ISO annual reliability assessment is a comprehensive annual study that includes the following:

- power flow studies;
- transient stability analysis; and
- voltage stability studies.

The annual reliability assessment focus is to identify facilities that demonstrate a potential of not meeting the applicable performance requirements specifically outlined in section 2.2.

This study is part of the annual transmission planning process and performed in accordance with section 24 of the ISO tariff and as defined in the Business Process Manual (BPM) for the Transmission Planning Process. The Western Electricity Coordinating Council (WECC) full-loop power flow base cases provide the foundation for the study. The detailed reliability assessment results are given in Appendix B and Appendix C.

#### 2.1.1 Backbone (500 kV and selected 230 kV) System Assessment

Conventional and governor power flow and stability studies were performed for the backbone system assessment to evaluate system performance under normal conditions and following power system contingencies for voltage levels 230 kV and above. The backbone transmission system studies cover the following areas:

- Northern California — Pacific Gas and Electric (PG&E) system;
- Southern California — Southern California Edison (SCE) system; and San Diego Gas and Electric (SDG&E) system.

#### 2.1.2 Regional Area Assessments

Conventional and governor power flow studies were performed for the local area non-simultaneous assessments under normal system and contingency conditions for voltage levels 60 kV through 230 kV. The regional planning areas were within the PG&E, SCE, SDG&E, and Valley Electric Association (VEA) service territories and are listed below.

- PG&E Local Areas:
  - Humboldt area;
  - North Coast and North Bay areas;
  - North Valley area;
  - Central Valley area (which includes Sierra, Sacramento, and Stockton divisions);
  - Greater Bay area;
  - Greater Fresno area;
  - Kern Area; and
  - Central Coast and Los Padres areas.
  
- SCE local areas:
  - Tehachapi and Big Creek Corridor;
  - Antelope-Bailey area;
  - North of Lugo area;
  - East of Lugo area;
  - Eastern area; and
  - Metro area.
  
- Valley Electric Association (VEA) area
- San Diego Gas Electric (SDG&E) local area

## 2.2 Reliability Standards Compliance Criteria

The 2013-2014 transmission plan spans a 10-year planning horizon and was conducted to ensure the ISO-controlled-grid is in compliance with the North American Electric Reliability Corporation (NERC) standards, Western Electricity Coordinating Council (WECC) regional criteria, and ISO planning standards across the 2014-2023 planning horizon. Sections 2.2.1 through 2.2.4 below describe how these planning standards were applied for the 2013-2014 study.

### 2.2.1 NERC Reliability Standards

#### 2.2.1.1 System Performance Reliability Standards (TPL-001 to TPL-004)

The ISO analyzed the need for transmission upgrades and additions in accordance with NERC reliability standards, which provide criteria for system performance requirements that must be met under a varied but specific set of operating conditions. The following TPL NERC reliability standards are applicable to the ISO as a registered NERC planning authority and are the primary drivers determining reliability upgrade needs:

- TPL-001 — System Performance Under Normal Conditions (Category A);
- TPL-002 — System Performance Following Loss of a Single Bulk Electric System (BES) Element (Category B);
- TPL-003 — System Performance Following Loss of Two or More BES Elements (Category C); and
- TPL-004 — System Performance Following Extreme BES Events (Category D).



## 2.2.2 WECC Regional Criteria

The WECC TPL system performance criteria are applicable to the ISO as a planning authority and sets forth additional requirements that must be met under a varied but specific set of operating conditions.<sup>17</sup>

## 2.2.3 California ISO Planning Standards

The California ISO Planning Standards specify the grid planning criteria to be used in the planning of ISO transmission facilities.<sup>18</sup> These standards cover the following:

- address specifics not covered in the NERC reliability standards and WECC regional criteria;
- provide interpretations of the NERC reliability standards and WECC regional criteria specific to the ISO-controlled grid; and
- identify whether specific criteria should be adopted that are more stringent than the NERC standards or WECC regional criteria.

## 2.3 Study Methodology and Assumptions

The following sections summarize the study methodology and assumptions used for the reliability assessment.

### 2.3.1 Study Methodology

As noted earlier, the backbone and regional planning region assessments were performed using conventional analysis tools and widely accepted generation dispatch approaches. These methodology components are briefly described below.

#### 2.3.1.1 Generation Dispatch

All generating units in the area under study were dispatched at or close to their maximum power (MW) generating levels. Qualifying facilities (QFs) and self-generating units were modeled based on their historical generating output levels.

#### 2.3.1.2 Power Flow Contingency Analysis

Conventional and governor power flow contingency analyses were performed on all backbone and regional planning areas consistent with NERC TPL-001 through TPL-004, WECC regional criteria and ISO planning standards as outlined in section 2.2. Transmission line and transformer bank ratings in the power flow cases were updated to reflect the rating of the most limiting component or element. All power system equipment ratings were consistent with information in the ISO Transmission Register.

---

<sup>17</sup> <http://compliance.wecc.biz/application/ContentPageView.aspx?ContentId=71>

<sup>18</sup> <http://www.caiso.com/Documents/TransmissionPlanningStandards.pdf>

Based on historical forced outage rates of combined cycle power plants on the ISO-controlled grid, the G-1 contingencies of these generating facilities were classified as an outage of the whole power plant, which could include multiple units. An example of such a power generating facility is the Delta Energy Center, which is composed of three combustion turbines and a single steam turbine.

### 2.3.1.3 Transient Stability Analyses

Transient stability simulations were performed as part of the backbone system assessment to ensure system stability and positive dampening of system oscillations for critical contingencies. This ensured that the transient stability criteria for performance levels B and C as shown in Table 2.3-1 were met.

Table 2.3-1: WECC transient stability criteria<sup>19</sup>

Performance Level	Disturbance	Transient Voltage Dip Standard	Minimum Transient Frequency Standard
B	Generator	Not to exceed 25% at load buses or 30% at non-load buses.	Not below 59.6 Hz for 6 cycles or more at a load bus.
	One Circuit		
	One Transformer	Not to exceed 20% for more than 20 cycles at load buses.	
	PDCI		
C	Two Generators	Not to exceed 30% at any bus.	Not below 59.0 Hz for 6 cycles or more at a load bus.
	Two Circuits	Not to exceed 20% for more than 40 cycles at load buses.	
	IPP DC		

### 2.3.2 Study Assumptions

The study horizon and assumptions below were modeled in the 2013-2014 transmission planning analysis.

<sup>19</sup>

<http://www.wecc.biz/library/Documentation%20Categorization%20Files/Regional%20Business%20Practices/TPL-001-WECC-RBP-2.1.pdf>

### **2.3.2.1 Study Horizon and Study Years**

The studies that comply with TPL-001, TPL-002 and TPL-003 were conducted for the near-term (2014-2018) and longer-term (2019-2023) periods as per the requirements of the reliability standards. According to the requirements under the TPL-004 standard, the studies that comply with the extreme events criteria were only conducted for the short-term scenarios (2014 -2018).

Within the near- and longer-term study horizon, the ISO conducted detailed analysis on 2015, 2018 and 2023. Some additional years were identified as required for assessment in specific planning regions.

### **2.3.2.2 Peak Demand**

The ISO-controlled grid peak demand in 2013 was 45,097 MW and occurred on June 28, 2013 at 4:53 p.m. The PG&E peak demand occurred on July 3, 2013 at 4:46 p.m. with 21,023 MW. The SCE peak occurred on September 5, 2013, at 3:33 p.m. with 22,634 MW and for VEA, it occurred on January 14, 2013, at 7:04 a.m. with 119 MW. Meanwhile, the peak demand for SDG&E occurred on August 30, 2013 at 3:53 p.m. with 4,638 MW.

Most of the ISO-controlled grid experiences summer peaking conditions and thus was the focus in all studies. For areas that experienced highest demand in the winter season or where historical data indicated other conditions may require separate studies, Winter Peak and Summer Off-Peak studies were also performed. Examples of such areas are Humboldt, Greater Fresno and the Central Coast in the PG&E service territory.

Table 2.3-2 summarizes these study areas and the corresponding peak scenarios for the reliability assessment.

Table 2.3-2: Summary of study areas, horizon and peak scenarios for the reliability assessment

Study Area	Near-term Planning Horizon		Long-term Planning Horizon
	2015	2018	2023
Northern California (PG&E) Bulk System*	Summer Peak Summer Off-Peak	Summer Peak Summer Light Load Summer Partial Peak	Summer Peak Summer Off-Peak
Humboldt	Summer Peak Winter Peak Summer Off-Peak	Summer Peak Winter Peak Summer Light Load	Summer Peak Winter Peak
North Coast and North Bay	Summer Peak Winter peak Summer Off-Peak	Summer Peak Winter Peak Summer Light Load	Summer Peak Winter peak
North Valley	Summer Peak Summer Off-Peak	Summer Peak Summer Light Load	Summer Peak
Central Valley (Sacramento, Sierra, Stockton)	Summer Peak Summer Off-Peak	Summer Peak Summer Light Load	Summer Peak
Greater Bay Area	Summer Peak Winter peak - (SF & Peninsula) Summer Off-Peak	Summer Peak Winter peak - (SF & Peninsula) Summer Light Load	Summer Peak Winter peak - (SF Only)
Greater Fresno	Summer Peak Summer Off-Peak	Summer Peak Summer Light Load Summer Partial Peak	Summer Peak
Kern	Summer Peak Summer Off-Peak	Summer Peak Summer Light Load	Summer Peak
Central Coast & Los Padres	Summer Peak Winter Peak Summer Off-Peak	Summer Peak Winter Peak Summer Light Load	Summer Peak Winter Peak
Consolidated Southern California	Summer Peak Summer Off-Peak	Summer Peak Summer Light Load	Summer Peak Summer Off-Peak
Southern California Edison (SCE) area	Summer Peak Summer Off-Peak	Summer Peak Summer Light Load	Summer Peak
San Diego Gas and Electric (SDG&E) area	Summer Peak Summer Off-Peak	Summer Peak Summer Light Load	Summer Peak
Valley Electric Association	Summer Peak Summer Off-Peak	Summer Peak Summer Light Load	Summer Peak

Note:

- Peak load conditions are the peak load in the area of study.
- Off-peak load conditions are approximately 50-65 per cent of peak loading conditions, such as weekend.
- Light load conditions are the system minimum load condition.
- Partial peak load condition represents a critical system condition in the region based upon loading, dispatch and facilities rating conditions.

### **2.3.2.3 Stressed Import Path Flows**

The ISO balancing authority is interconnected with neighboring balancing authorities through interconnections over which power can be imported to or exported from the ISO area. The power that flows across these import paths are an important consideration in developing the study base cases. For the 2013-2014 planning study, and consistent with operating conditions for a stressed system, high import path flows were modeled to serve the ISO's BAA load. These import paths are discussed in more detail in section 2.3.2.10.

### **2.3.2.4 Contingencies**

In addition to studying the system under TPL-001 (normal operating conditions), the following provides additional detail on how the TPL-002, TPL-003 and TPL-004 standards were evaluated.

#### **Loss of a single bulk electric system element (BES) (TPL-002 - Category B)**

The assessment considers all possible Category B contingencies based upon the following:

- loss of one generator (B1);
- loss of one transformer (B2);
- loss of one transmission line (B3);
- loss of a single pole of DC lines (B4);
- loss of the selected one generator and one transmission line (G-1/L-1), where G-1 represents the most critical generating outage for the evaluated area; and
- loss of both poles of a Pacific DC Intertie.

#### **Loss of two or more BES elements (TPL-003 - Category C)**

The assessment considers the Category C contingencies with the loss of two or more BES elements which produce the more severe system results or impacts based on the following:

- breaker and bus section outages (C1 and C2);
- combination of two element outages with system adjustment after the first outage (C3);
- loss of both poles of DC lines (C4);
- all double circuit tower line outages (C5);
- stuck breaker with a Category B outage (C6 thru C9); and
- loss of two adjacent transmission circuits on separate towers.

#### **Extreme contingencies (TPL-004 - Category D)**

The assessment considers the Category D contingencies of extreme events which produce the more severe system results or impact as a minimum based on the following:

- loss of 2 nuclear units;
- loss of all generating units at a station;
- loss of all transmission lines on a common right-of-way;
- loss of substation (One voltage level plus transformers); and
- certain combinations of one element out followed by double circuit tower line outages.

### **2.3.2.5 Generation Projects**

The ISO modeled approximately a 20 percent renewable energy scenario for the 2018 reliability study case. This included the renewable generation and associated transmission in the ISO queue that was expected to be in service by 2017.

For the 2023 reliability study cases, the ISO modeled the base 33 percent RPS portfolio. However, in some areas where renewable generation modeling was substantial, some sensitivity studies were performed without any expected renewable generation modeled. These studies were performed to address the possibility that the modeled renewable generation would not actually be built or would not be operating because of very low intermittent wind and insolation levels.

Approximately 20 percent of California's ISO's currently operating total generating capacity uses coastal and estuarine water for once-through cooling. On May 4, 2010, the State Water Resources Control Board (SWRCB) adopted a statewide policy on the use of coastal and estuarine waters for power plant cooling. The policy established uniform, technology-based standards to implement federal Clean Water Act section 316(b), which requires that the location, design, construction and capacity of cooling water intake structures reflect the best technology available for minimizing adverse environmental impact. The policy was approved by the Office of Administrative Law on September 27, 2010 and became effective on October 1, 2010. It required owners or operators of existing non-nuclear fossil fuel power plants using once-through cooling to submit an implementation plan to the SWRCB by April 1, 2011. In most cases, the plans selected an alternative that would achieve compliance, contingent on future commercial arrangements, by a date specified for each facility identified in the policy. The specific retirement assumptions are documented in the local area descriptions later in this chapter.

### **2.3.2.6 Transmission Projects**

The study included all existing transmission in service and the expected future projects that have been approved by the ISO but are not yet in service. Refer to Tables 7.1.1 and 7.1.2 of chapter 7 (Transmission Project Updates) for the list of projects that were modeled in the base cases but that are not yet in service. Also included in the study cases were generation interconnection related transmission projects that were included in executed generator interconnection agreements (LGIA) for generation projects included in the base case.

### **2.3.2.7 Load Forecast**

The local area load forecasts used in the study were developed by participating transmission owners using the revised mid-case California Energy Demand Forecast 2012-2022 released by California Energy Commission (CEC) dated June 2012 with the *Mid-Case LSE and Balancing Authority Forecast* spreadsheet updated as of August 16, 2012 as the starting point because the CEC forecast did not provide bus-level demand projections.

In addition to the CEC Energy Demand Forecast, the ISO incorporated incremental uncommitted energy savings in forecast utilized in the studies. The ISO used the CEC's low-savings identified in the *Energy Efficiency Adjustments for a Managed Forecast: Estimates of Incremental Uncommitted Energy Savings Relative to the California Energy Demand Forecast*

2012-2022, dated September 14, 2012. The low-savings of incremental uncommitted energy savings was allocated to the bus-level by applying the methodology developed by the CEC staff as a part of the AB1318 analysis.

The 1-in-10 load forecasts were modeled in each of the local area studies. The 1-in-5 coincident peak load forecasts were used for the backbone system assessments as it covers a vast geographical area with significant temperature diversity. More details of the demand forecast are provided in the discussion sections of each of the study areas.

### **Light Load and Off-Peak Conditions**

The assessment evaluated the light load and off-peak conditions in all study areas of the ISO balancing authority to satisfy NERC compliance requirement 1.3.6 for TPL-001, TPL-002 and TPL-003. The ISO light load conditions represented the system minimum load conditions while the off-peak load conditions ranged from 50 percent to 70 percent of the peak load in that area, such as weekends. Critical system conditions in specific study areas can occur during partial peak periods because of loading, generation dispatch and facility rating status and were studied accordingly.

#### **2.3.2.8 Reactive Power Resources**

Existing and new reactive power resources were modeled in the study base cases to ensure realistic reactive power support capability. These resources include generators, capacitors, static var compensators (SVC) and other devices. Refer to area-specific study sections for a detailed list of generation plants and corresponding assumptions. Two of the key reactive power resources that were modeled in the studies include the following:

- all shunt capacitors in the SCE service territory; and
- static var compensators or static synchronous compensator at several locations such as Potrero, Newark, Humboldt, Rector, Devers and Talega substations.

For a complete resources list, refer to the base cases available at the ISO Market Participant Portal secured website (<https://portal.caiso.com/Pages/Default.aspx>).<sup>20</sup>

#### **2.3.2.9 Operating Procedures**

ISO operating procedures for the system under normal (pre-contingency) and emergency (post-contingency) conditions were observed in this study.

Table 2.3-3 summarizes major operating procedures that are utilized in the ISO-controlled grid.

---

<sup>20</sup> This site is available to market participants who have submitted a Non-Disclosure Agreement (NDA) and is approved to access the portal by the ISO. For instructions, go to <http://www.caiso.com/Documents/Regional%20transmission%20NDA>.

Table 2.3-3: Operating procedures for normal and emergency conditions

Operating Procedure	Scope
7810	San Diego Area Generation Requirements
7620	South of Lugo Generation Requirements
7630	Orange County Area Requirements
7570	South of Lugo 500 kV lines
6110	COI Master Operating Procedure
7430	Fresno Area Operating Procedures
6310	Path 15 (Midway-Los Banos) Operating Procedure
6410	Path 26 – Midway-Vincent Operating Procedure
6510	Southern California Import Transmission (SCIT)

### 2.3.2.10 Firm Transfers

Power flow into and within the ISO BAA on the major power transmission paths was modeled as firm transfers. In general, the northern California (PG&E) system has four interties with the outside system and southern California. Out of these four ties, Path 66 (COI) and Path 26 are two major transfer paths that wheel large amounts of power between northern California and its neighbors. Table 2.3-4 lists the power transfers that were modeled in each scenario on these paths in the northern area assessment. The table shows the range of the transfers modeled in the cases. The contractual arrangement to provide SPS/RAS between CDWR and PG&E will expire in 2014. The assessments took this into consideration with path flows at transfer levels without the action schemes (RAS) or special protection systems (SPS) being available. Negative flow in the table indicates a reversal of flow direction than indicated for the path.

Path 15 flow limit is 5400 MW in the south-to-north direction. This direction of flow usually occurs under off-peak load conditions. Under peak load conditions, the flow on Path 15 is in the opposite direction. In the peak power flow cases it was modeled at significantly lower values than its possible limit (2000-3265 MW) because unrealistic generation dispatch would be needed to achieve the north-to-south Path 15 flow limit. In the summer off-peak cases, the Path 15 flow was modeled lower than its limit because the Morro Bay generation plant was assumed to be off-line. This plant has significant impact on the Path 15 flow, and the Path 15 flow is lower when this plant is not generating. Bringing Path 15 flow to 5400 MW with the Morro Bay generation off-line would cause overload on the Midway-Gates 500 kV line under normal system conditions. The studies determined that without the Morro Bay generation, Path 15 flow should not exceed 5240 MW to avoid this overload.



Path 26 flow was modeled up to its north-to-south limit of 4000 MW in the peak load cases. Lower Path 26 flow modeled in the 2018 and 2023 cases was due to the assumption that some of the generation plants in PG&E would retire. Under the off-peak conditions, the Path 26 flow was lower or in the opposite direction.

Path 66 (COI) flow was modeled at its north-to-south limit of 4800 MW in all summer peak cases. In the off-peak cases, the Path 66 flow was in the reverse direction which did not have an impact on the ISO since the limiting facilities and limiting contingencies when the flow on Path 66 is from south to north are in the Northwest. In the winter peak cases, the flow on Path 66 was lower than in the summer peak due to the lower ISO load and thus less need for the imported power from the Northwest.

Table 2.3-4: Major paths and power transfer ranges in the Northern California assessment

Path	Path Flow Ranges (MW)		
	Summer Peak	Summer Off-Peak	Winter Peak
Path 15 (N-S)	(-800)-1100	( -5240) –(-570)	766-1045
Path 26 (N-S)	1520-4000	(-2045)-1160	1459-1508
Path 66 (N-S)	4800	(-3380)-1240	2455-2504
PDCI (N-S)	2605-3100	0-500	1200-2500

Table 2.3-5 lists the major paths in the SCE service territory in southern California and the corresponding power transfer ranges under various system conditions as modeled in the base cases for the assessment.

Table 2.3-5: Major Path flow ranges in southern area (SCE and SDG&amp;E system) assessment

Path	Path Flow Range (MW)		
	Path Rating or SOL (MW)	Flow Range in Local Cases (MW)	Flow Range in Consolidated Southern California Cases (MW)
Path 26 (N-S)	4000/-3000	-3000 to 4,000	-1572 to 4000
PDCI (N-S)	3100/-3100	0 to 3,100	-500 to 3100
West of River	10623	5000 to 9700	4500 to 8214
East of River	9300	3,200 to 6,000	3658 to 5569
Path 42	600	150 to 1000	272 to 867
Path 61 (N-S)	2400/-900	550 to 1900	121 to 1611
South of San Onofre (N-S)	2200	628 to 801	-516 to 74
ISO - Mexico (S-N)	800/-408	-5 to 5	2 to 4
IID-SDGE (S-N)	270	-25 to 676	-129 to 54
North of San Onofre (S-N)	2440	-	-117 to 473

### 2.3.2.11 Protection Systems

To ensure reliable operation of the system, many RAS or special SPS have been installed in certain areas of the system. These protection systems drop load or generation upon detecting system overloads by strategically tripping circuit breakers under selected contingencies. Some SPS are designed to operate upon detecting unacceptable low voltage conditions caused by certain contingencies. The SPS on the system are listed in Appendix A.

### **2.3.2.12 Control Devices**

Control devices modeled in the study included key reactive resources listed in section 2.3.2.8 and the direct current (DC) controls for the following lines:

- Pacific Direct Current Intertie (PDCI);
- Inter-Mountain power plant direct current (IPPDC); and
- Trans Bay Cable project.

For complete details of the control devices that were modeled in the study, refer to the base cases that are available through the ISO Market Participant Portal secured website.

## 2.4 Northern California Bulk Transmission System Assessment

### 2.4.1 Northern California Bulk Transmission System Description

The figure below provides a simplified map of the PG&E bulk transmission system.

Figure 2.4-1: Map of PG&E bulk transmission system



The 500 kV bulk transmission system in northern California consists of three parallel 500 kV lines that traverse the state from the California-Oregon border in the north and continue past Bakersfield in the south. This system transfers power between California and other states in the northwestern part of the United States and western Canada. The transmission system is also a gateway for accessing resources located in the sparsely populated portions of northern California, and the system typically delivers these resources to population centers in the Greater Bay Area and Central Valley. In addition, a large number of generation resources in the central

California area are delivered over the 500 kV systems into southern California. The typical direction of power flow through Path 26 (three 500 kV lines between Midway and Vincent substations) is from north to south during on-peak load periods and in the reverse direction during off-peak load periods. The typical direction of power flow through Path 15 (Los Banos Gates #1 and #3 500 kV lines and Los Banos-Midway #2 500 kV line) is from south to north during off-peak load periods and the flows can be either direction south to north or north to south under peak conditions. The typical direction of power flow through California-Oregon Intertie (COI, Path 66) and through the Pacific DC Intertie (Bi-pole DC transmission line connecting the Celilo Substation in Washington State with the Sylmar Substation in Southern California) is from north to south during summer on-peak load periods and in the reverse direction during off-peak load periods in California or Winter Peak periods in Pacific Northwest.

Because of this bi-directional power flow pattern on the 500 kV Path 26 lines and on COI, both the summer peak (N-S) and off-peak (S-N) flow scenarios were analyzed, as well as a partial peak scenario. Transient stability and post transient contingency analyses were also performed for all flow patterns and scenarios.

## 2.4.2 Study Assumptions and System Conditions

The northern area bulk transmission system study was performed consistent with the general study methodology and assumptions described in section 2.3. The ISO-secured website lists the contingencies that were performed as part of this assessment. In addition, specific methodology and assumptions that are applicable to the northern area bulk transmission system study are provided in the next sections. The studies for the PG&E Bulk Transmission System analyzed the most critical conditions: Summer Peak cases for the years 2015, 2018 and 2023, Summer Light Load and Partial Peak cases for 2018 and Summer Off-Peak cases for 2015 and 2023. All single and common mode 500 kV system outages were studied, as well as outages of large generators and contingencies involving stuck circuit breakers and delayed clearing of single-phase-to ground faults. Also, extreme events such as contingencies that involve a loss of major substations and all transmission lines in the same corridors were studied.

### Generation and Path Flows

The bulk transmission system studies use the same set of generation plants that are modeled in the local area studies. In this planning cycle, the scope of the study includes exploring the impacts of meeting the RPS goal in 2023 in addition to the conventional study that models new generators according to the ISO guidelines for modeling new generation interconnection projects. Therefore, an additional amount of renewable resources was modeled in the 2018 and 2023 base cases according to the information in the ISO large generation interconnection queue. Only those resources that are proposed to be on line in 2018 or prior to 2018 were modeled in the 2018 cases. 2015 cases modeled new generation projects that are expected to be in service in 2015 or prior to 2015. A summary of generation is provided in each of the local planning areas within the PG&E area.

Because the studies analyzed the most critical conditions, the flows on interfaces connecting Northern California with the rest of the WECC system were modeled at or close to the paths' flow limits, or as high as the generation resource assumptions allowed. Table 2.4-1 lists all

major path flows affecting the 500 kV systems in northern California along with the hydroelectric generation dispatch percentage in the area.

Table 2.4-1: Major import flows for the northern area bulk study

Parameter	2015 Summer Peak	2015 Summer Off-Peak	2018 Summer Peak	2018 Summer Light Load	2018 Summer Partial Peak	2023 Summer Peak	2023 Summer Off-Peak
California-Oregon Intertie Flow (N-S) (MW)	4800	-3000	4800	1240	4630	4800	-3380
Pacific DC Intertie Flow (N-S) (MW)	2700	0	2800	500	2250	2605	0
Path 15 Flow (S-N) (MW)	-1100	4950	80	570	2040	800	5240
Path 26 Flow (N-S) (MW)	4000	-890	2460	1160	330	1520	-2045
Northern California Hydro % dispatch of nameplate	80	45	82	56	42	82	45

### Load Forecast

Per the ISO planning criteria for regional transmission planning studies, the demand within the ISO area reflects a coincident peak load for 1-in-5-year forecast conditions for the Summer Peak cases. Loads in the off-peak case were modeled at approximately 50 percent of the 1-in-5 Summer Peak load level. The light load cases modeled the lowest load in the PG&E area that appears to be lower than the off-peak load. Table 2.4-2 shows the assumed load levels for selected areas under Summer Peak and non-peak conditions.

Table 2.4-2: Load modeled in the northern area bulk transmission system assessment

Scenario	Area	Load (MW)	Loss (MW)	Total (MW)
<b>2015 Summer Peak</b>	PG&E	27,817	1,062	28,879
	SDG&E	5,183	189	5,372
	SCE	24,833	437	25,270
	ISO	57,832	1,687	59,521
<b>2015 Summer Off-Peak</b>	PG&E	13,246	594	13,840
	SDG&E	3,503	85	3,588
	SCE	11,010	210	11,220
	ISO	27,759	889	28,648
<b>2018 Summer Peak</b>	PG&E	28,610	1,052	29,662
	SDG&E	5,485	171	5,656
	SCE	24,568	414	24,982
	ISO	58,663	1,637	60,300
<b>2018 Summer Partial Peak</b>	PG&E	26,022	945	26,967
	SDG&E	5,485	169	5,654
	SCE	23,068	380	23,448
	ISO	54,575	1,494	56,069
<b>2018 Summer Light Load</b>	PG&E	11,667	334	12,001
	SDG&E	3,503	93	3,596
	SCE	15,010	242	15,252
	ISO	30,180	669	30,849
<b>2023 Summer Peak</b>	PG&E	29,821	1,077	30,898
	SDG&E	5,957	216	6,173
	SCE	26,241	449	26,690
	ISO	62,019	1,742	63,761
<b>2023 Summer Off-Peak</b>	PG&E	13,910	589	14,499
	SDG&E	3,697	75	3,772
	SCE	17,777	416	18,193
	ISO	35,384	1,080	36,464

## Existing Protection Systems

Extensive SPS or RAS are installed in the northern California area's 500 kV systems to ensure reliable system performance. These systems were modeled and included in the contingency studies. A comprehensive detail of these protection systems are provided in various ISO operating procedures, engineering and design documents.

### 2.4.3 Assessment and Recommendations

The ISO conducted detailed planning assessment based on the study methodology identified in section 2.3 to comply with the reliability standards requirements of section 2.2. Details of the planning assessment results are presented in Appendix B. The ISO study assessment of the northern bulk system yielded the following conclusions:

- One overload is expected under Peak Summer conditions in 2018 and 2023 with all facilities in service and with single or multiple contingencies. To mitigate this overload, congestion management may be used.
- One transmission line (Gates-Midway 500 kV) may load close to 100 percent of its normal rating under Off-Peak conditions of 2023 with all facilities in service. The loading may be reduced by congestion management.
- Three overloads are expected under peak load conditions with Category B contingencies. These overloads may be mitigated by congestion management and bypassing series capacitors. Upgrading one or two of these transmission lines may be another alternative.
- No Category B overloads are expected under off-peak and light load conditions.
- A number of potential overloads for Category C contingencies were identified:
  - For the Summer Peak cases, ten overloads were identified with the Category C contingencies studied in 2015 case and four overloads in 2018 and 2023 cases.
  - For the 2018 Partial peak, three 115 kV transmission lines may overload with one Category C contingency
  - Under the Off-Peak conditions, one facility (Olinda 500/230 kV bank) may overload with one Category C contingency. This overload is mitigated by applying the existing SPS.

There is one approved transmission project that will mitigate three Category C overloads that may occur under peak load conditions and another approved transmission project that will mitigate three other Category C overloads under partial peak load conditions. Upgrading terminal equipment on one substation, which will be performed as a part of the transmission system maintenance, will mitigate another Category C overload. Prior to the approved upgrades being completed, congestion management or modification of the existing RAS may be used.



The ISO-recommended solutions to mitigate the identified reliability concerns are as follows:

- further investigate mitigation measures for the 500 kV double outage South of Table Mountain to determine if any system upgrades or RAS modifications will be economic after the existing contract with CDWR to trip CDWR generation and pumping load expires (see Chapter 5 regarding economic studies);
- install SPS to bypass series capacitors on the Round Mountain-Table Mountain 500 kV lines #1 and 2 in case if either one of these lines overloads with an outage of the parallel line While another alternative is to reduce COI flow according to the seasonal nomogram;
- rerating of the Delevan-Cortina 230 kV line;
- adjust the Weed Junction phase shifter taps or obtain short-term emergency ratings for the Crag View-Weed Junction – Copco and Delta-Cascade 115 kV lines;
- use congestion management to reduce generation from Contra Costa to mitigate overloads on the Lone Tree – Cayetano 230 kV, and Cayetano – N. Dublin 230 kV lines; and
- dispatch generation from the Helms pump-storage power plant for the partial peak load conditions until the ISO-approved transmission upgrades in the Fresno area are completed.

The ISO will also work with CDWR to identify the settings on the protection relays on the Midway irrigation pumps.

The ISO has received a project submission for the PG&E Bulk Transmission System in the 2013 Request Window — Table Mountain – Tesla Transmission Project. This project was submitted as a conceptual plan that requires further evaluation by PG&E. The purpose of the project identified by PG&E is to preserve COI's existing import capability and avoid curtailment on existing resources as well as avoid potential impact of any new resources that may be connected to the transmission system north of the Tesla substation. In future planning cycles the ISO will continue to monitor the COI requirements and continue to work with PG&E on this or other projects as required.

## 2.5 PG&E Local Areas Assessment

In addition to the PG&E bulk area study, studies were performed for its eight local areas.

### 2.5.1 Humboldt Area

#### 2.5.1.1 Area Description

The Humboldt area covers approximately 3,000 square miles in the northwestern corner of PG&E's service territory. Some of the larger cities that are served in this area include Eureka, Arcata, Garberville and Fortuna. The highlighted area in the adjacent figure provides an approximate geographical location of the Humboldt area.



Humboldt's electric transmission system is composed of 60 kV and 115 kV transmission facilities. Electric supply to this area is provided primarily by generation at Humboldt Bay power plant and local qualifying facilities generation units. Additional electric supply is provided by transmission imports via two 100 mile, 115 kV circuits from the Cottonwood substation east of this area and one 80 mile 60 kV circuit from the Mendocino substation south of this area.

Historically, the Humboldt area experiences its highest demand during the winter season. For the 2013-2014 transmission planning studies, a Summer Peak and Winter Peak assessment was performed. Additionally the Summer Off-Peak condition for 2015 and the Summer Light Load condition for 2018 assessments were also performed. For the Summer Peak assessment, a simultaneous area load of 182 MW in the 2018 and 194 MW in the 2023 time frames were assumed. For the Winter Peak assessment, a simultaneous area load of 193 MW and 205 MW in the 2018 and 2023 time frames were assumed. An annual load growth of about 2.7 MW per year for the Summer Peak and 2.2 MW per year for Winter Peak was also assumed.

#### 2.5.1.2 Area Specific Assumptions and System Conditions

The Humboldt area study was performed in accordance with the general study assumptions and methodology described in section 2.3. The ISO-secured website lists the contingencies that were evaluated as a part of this assessment. Specific assumptions and methodology applied to the Humboldt area study are provided below. Summer Peak and Winter Peak assessments were performed for the study years 2015, 2015 and 2023. Additionally a 2015 Summer Off-Peak condition and a 2018 Summer Light Load condition were also studied.

## Generation

Generation resources in the Humboldt area consist of market, qualifying facilities and self-generating units. The largest resource in the area is the 166 MW Humboldt Bay Power Plant. This facility was re-powered and started commercial operation in the summer of 2010. It replaced the Humboldt power plant, which was retired in November 2010. In addition, the 12 MW Blue Lake Power Biomass Project was placed into commercial operation on August 27, 2010. Table 2.5-1 lists a summary of the generation in the Humboldt area, with detailed generation listed in Appendix A.

Table 2.5-1: Humboldt area generation summary

<b>Generation</b>	<b>Capacity (MW)</b>
Thermal	191
Hydro	5
Biomass	62
<b>Total</b>	<b>258</b>

## Load Forecast

Loads within the Humboldt area reflect a coincident peak load for 1-in-10-year forecast conditions in each study year. Table 2.5-2 and Table 2.5-3 summarize loads modeled in the studies for the Humboldt area.

Table 2.5-2: Load forecasts modeled in Humboldt area assessment, Summer Peak

<b>1-in-10 Year Non-Simultaneous Load Forecast</b>			
<b>PG&amp;E Area Name</b>	<b>Summer Peak (MW)</b>		
	<b>2015</b>	<b>2018</b>	<b>2023</b>
<b>Humboldt</b>	<b>174</b>	<b>182</b>	<b>194</b>

Table 2.5-3: Load forecasts modeled in Humboldt area assessment, Winter Peak

<b>1-in-10 Year Non-Simultaneous Load Forecast</b>			
<b>PG&amp;E Area Name</b>	<b>Winter Peak (MW)</b>		
	<b>2015</b>	<b>2018</b>	<b>2023</b>
<b>Humboldt</b>	<b>186</b>	<b>193</b>	<b>205</b>

### 2.5.1.3 Assessment and Recommendations

The ISO conducted detailed planning assessment based on the study methodology identified in section 2.3 to comply with the reliability standards requirements of section 2.2. Details of the planning assessment results are presented in Appendix B. The ISO study of the Humboldt area yielded the following conclusions:

- No Category A or Category B thermal violations were identified;
- Low voltages and voltage deviations may occur for Category B and Category C contingencies prior to installation of reactive support on the 60 kV substations in the Maple Creek and Garberville areas;
- Low voltages and large voltage deviations were identified for various Category C contingencies in the Bridgeville to Garberville 60kV corridor prior to the Bridgeville – Garberville 115kV line being placed in-service;
- Voltage and voltage deviation concerns were identified on several 60 kV buses in the summer and winter peak conditions for various Category B and Category C contingencies in and around the Blue Lake Power Plant, Arcata, Orick, Big Lagoon and Trinidad substations;
- Nine transmission facilities may become overloaded for various Category C contingencies both in summer and winter peak conditions.

The identified overloads will be addressed by the following proposed solutions:

- Complete the approved transmission solution of building a new Bridgeville-Garberville 115 kV transmission line. This transmission solution will address the overload on the various 60kV line sections in the Bridgeville-Mendocino 60 kV corridor that is expected under multiple Category C contingencies and solve voltage concerns in the Bridgeville area. This new 115kV transmission line project was approved by the ISO in the 2011-2012 transmission plan;
- Utilize PG&E's actions plans that include operator actions such as generation adjustments and load dropping to address the various category C related thermal violations found in the Humboldt area;

- On an interim basis, utilize PG&E action plans to address low voltages and voltage deviation concerns in the most northern part of Humboldt County.

The ISO received one project proposal in the Humboldt area from PG&E to build a new 115 kV line between Humboldt and Cottonwood. The project aims to reduce the Humboldt area's dependence on Humboldt Bay Generating Station by adding an additional 115 kV supply source into Humboldt. The project will maintain the peak load serving capability in the Humboldt area for any extreme contingency scenarios such as the loss of the entire Humboldt Bay Power Plant (classified as a NERC Category D event). After reviewing the proposal, the ISO has determined that the proposed 115 kV line between Humboldt and Cottonwood was not needed to maintain reliability in the Humboldt area in accordance with the NERC and CAISO planning standards.

## 2.5.2 North Coast and North Bay Areas

### 2.5.2.1 Area Description

The highlighted areas in the adjacent figure provide an approximate geographical location of the North Coast and North Bay areas.

The North Coast area covers approximately 10,000 square miles north of the Bay Area and south of the Humboldt area along the northwest coast of California. It has a population of approximately 850,000 in Sonoma, Mendocino, Lake and a portion of Marin counties, and extends from Laytonville in the north to Petaluma in the south.

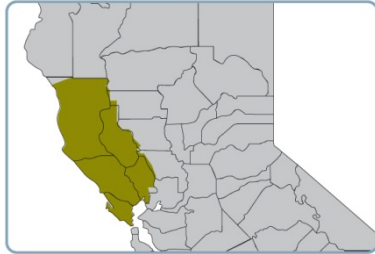

The North Coast area has both coastal and interior climate regions. Some substations in the North Coast area are summer peaking and some are winter peaking. For the Summer Peak assessment, a simultaneous area load of 827 MW in 2018 and 916 MW in 2023 time frames was assumed. For the Winter Peak assessment, a simultaneous area load of 693 MW and 766 MW in the 2018 and 2023 time frames was assumed. An annual load growth for Summer Peak of approximately 16 MW and Winter Peak of approximately 13 MW per year was also assumed. A significant amount of North Coast generation is from geothermal (The Geysers) resources. The North Coast area is connected to the Humboldt area by the Bridgeville-Garberville-Laytonville 60 kV lines. It is connected to the North Bay by the 230 kV and 60 kV lines between Lakeville and Ignacio and to the East Bay by 230 kV lines between Lakeville and Vaca Dixon.

North Bay encompasses the area just north of San Francisco. This transmission system serves Marin, Napa and portions of Solano and Sonoma counties.

The larger cities served in this area include Novato, San Rafael, Vallejo and Benicia. North Bay's electric transmission system is composed of 60 kV, 115 kV and 230 kV facilities supported by transmission facilities from the North Coast, Sacramento and the Bay Area. For the Summer Peak assessment, a simultaneous area load of 824 MW and 857 MW in the 2018 and 2023 time frames was assumed. For the Winter Peak assessment, a simultaneous area load of 779 MW and 810 MW in the 2018 and 2023 time frames was assumed. An annual load growth for Summer Peak of approximately 11 MW and for Winter Peak of approximately 10 MW per year was also assumed. Like the North Coast, the North Bay area has both summer peaking and winter peaking substations. Accordingly, system assessments in this area include the technical studies for the scenarios under Summer Peak and Winter Peak conditions that reflect different load conditions mainly in the coastal areas.

### 2.5.2.2 Area-Specific Assumptions and System Conditions

The North Coast and North Bay area study was performed consistent with the general study assumptions and methodology described in section 2.3. The ISO's secured website lists the contingencies that were performed as part of this assessment. Specific assumptions and methodology that were applied to the North Coast and North Bay area studies are provided below. Summer Peak and Winter Peak assessments were done for North Coast and North Bay

areas for the study years 2014, 2017 and 2022. Additionally a 2014 Summer Light Load condition and a 2017 Summer Off-Peak condition were studied for the North Coast and North Bay areas.

### Generation

Generation resources in the North Coast and North Bay areas consist of market, qualifying facilities and self-generating units. Table 2.5-4 lists a summary of the generation in the North Coast and North Bay area, with detailed generation listed in Appendix A.

Table 2.5-4: North Coast and North Bay area generation summary

<b>Generation</b>	<b>Capacity (MW)</b>
Thermal	54
Hydro	26
Geo Thermal	1,533
Biomass	6
<b>Total</b>	<b>1,619</b>

The studies also modeled two future renewable generation projects. A new 10 MW biomass generation project was assumed to be interconnected to the Lakeville #2 (Petaluma-Lakeville) 60 kV line. The second project, a 35 MW geothermal plant was modeled to be interconnected to the Geysers #3-Cloverdale 115 kV line; however this plant has since been withdrawn from the ISO queue.

### Load Forecast

Loads within the North Coast and North Bay areas reflect a coincident peak load for 1-in-10-year forecast conditions for each study year.

Table 2.5-5 and Table 2.5-6 summarize the substation loads assumed in the studies for North Coast and North Bay areas under summer and Winter Peak conditions.

Table 2.5-5: Load forecasts modeled in North Coast and North Bay area assessments, Summer Peak

<b>1-in-10 Year Non-Simultaneous Load Forecast</b>			
<b>PG&amp;E Area Name</b>	<b>Summer Peak (MW)</b>		
	<b>2015</b>	<b>2018</b>	<b>2023</b>
<b>North Coast</b>	779	827	916
<b>North Bay</b>	793	824	857

Table 2.5-6: Load forecasts modeled in North Coast and North Bay area assessments, Winter Peak

<b>1-in-10 Year Non-Simultaneous Load Forecast</b>			
<b>PG&amp;E Area Name</b>	<b>Winter Peak (MW)</b>		
	<b>2015</b>	<b>2018</b>	<b>2023</b>
<b>North Coast</b>	654	693	766
<b>North Bay</b>	750	779	810

### **2.5.2.3 Assessment and Recommendations**

The ISO conducted a detailed planning assessment based on the study methodology identified in section 2.3 to comply with the reliability standards requirements of section 2.2. Details of the planning assessment results are presented in Appendix B. A summary of the ISO assessment of the PG&E North Coast and North Bay revealed the following reliability concerns:

- No Category A thermal violations were found in this year's analysis.
- Overall there were 6 Category B and 37 Category C overloads identified in this year's assessment
- Low voltage violations have been found in 2 local pockets for Category B conditions and in 5 local pockets for Category C conditions.
- Voltage deviation concerns were identified in 5 local pockets for Category B conditions and in 6 local pockets for Category C conditions.



The identified violations will be addressed as follows:

- One Category B overload may require reconductoring a transmission line by the summer of 2023. No mitigation is proposed at this time but will be monitored in future cycles.
- Certain severe local low voltage and voltage deviation violations under Category C conditions which were resulting in a voltage collapse in the Mendocino – Garberville 60 kV corridor will need additional reactive support installed. No mitigation is proposed at this time but will be monitored in future planning cycles. The ISO will continue to work with PG&E on various mitigation alternatives as a part of the conceptual Mendocino Long term study.
- All other Category B and Category C issues already either already have a project approved by the ISO or have a PG&E operating procedure in place as mitigation. In cases where the approved projects have not yet come into service, interim operating solutions or action plans may need to be put in place as mitigation. The ISO will continue to work with PG&E in developing the interim plans as required

The ISO received one proposed transmission project through the 2013 Request Window.

#### Laytonville 60 kV Circuit Breaker Installation

PG&E submitted this project through the 2013 Request Window per ISO planning standards Planning for New Transmission vs. Involuntary Load Interruption Standard (*Section VI - 4 reducing load outage exposure through a BCR above 1.0*). The project scope is to construct a loop bus at Laytonville Substation, install three (3) Supervisory Control And Data Acquisition (SCADA)-operable circuit breakers and connect the Laytonville-Covelo 60 kV Line into the Laytonville Substation.

The Garberville-Laytonville 60 kV Line is comprised of 40 miles of mixed aluminum conductors, constructed on wood poles. This line normally provides electric service to Laytonville, Covelo and Willits substations via Laytonville Substation, for a total customer count of approximately 9,443 (23 MW of load). The Laytonville-Willits 60 kV Line is comprised of 23.4 miles of mixed aluminum conductor constructed on wood poles. This line normally provides electric service to Willits Substation which serves approximately 6,468 customers (16 MW of load). Laytonville Substation is equipped with a single bus, one Motor-Operable Air Switch (MOAS) connected to the Laytonville-Willits 60 kV Line, and one circuit breaker (CB 32) connected to the Garberville-Laytonville 60 kV Line. Covelo Substation, which serves approximately 1,330 electric customers, is radially connected to the Laytonville-Willits 60 kV Line via a 16 mile tap line. Historical outage data shows that the Laytonville-Willits 60 kV Line has experienced a total of 12 outages within the past 5 years, resulting in over 2.2 million customer outage minutes, due mainly to weather and car-pole accidents.

This project will protect against customer interruptions due to an outage of the Laytonville-Willits 60 kV or the Laytonville-Covelo 60 kV line. The ISO determined that the Laytonville 60 kV Circuit Breaker Installation project is needed based on the BCR of 1.19 per ISO Grid Planning Standards, Section VI-4. The project is expected to cost between \$5 million and \$10 million and has an in-service date of December 2015.

Two other projects in the North Coast and North Bay area submitted by PG&E were conceptual in nature. These were for the Mendocino Long Term Study proposal and San Rafael Long term study proposal. The two studies are still underway at PG&E and no recommendations have been made on these projects by the ISO within this planning cycle. This year's analysis shows that the previously approved projects in the North Coast and North Bay area are still needed to mitigate the identified reliability concerns. These projects include the following:

- Ignacio - Alto 60 kV Line Voltage Conversion Project;
- Napa - Tulucay No. 1 60 kV Line Upgrade;
- Tulucay No. 1 230-60 kV Transformer Capacity Increase; and,
- Geyser #3 - Cloverdale 115 kV Line Switch Upgrade.

## 2.5.3 North Valley Area

### 2.5.3.1 Area Description

The North Valley area is located in the northeastern corner of the PG&E's service area and covers approximately 15,000 square miles. This area includes the northern end of the Sacramento Valley, as well as parts of the Siskiyou and Sierra mountain ranges and the foothills. Chico, Redding, Red Bluff and Paradise are some of the cities in this area. The adjacent figure depicts the approximate geographical location of the North Valley area.

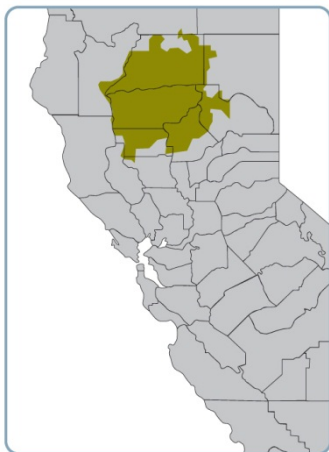

North Valley's electric transmission system is composed of 60 kV, 115 kV, 230 kV and 500 kV transmission facilities. The 500 kV facilities are part of the Pacific Intertie between California and the Pacific Northwest. The 230 kV facilities, which complement the Pacific Intertie, also run north to south with connections to hydroelectric generation facilities. The 115 kV and 60 kV facilities serve the local electricity demand. In addition to the Pacific Intertie, there is one other external interconnection to the PacifiCorp system. The internal transmission system connections to the Humboldt and Sierra areas are via the Cottonwood, Table Mountain, Palermo and Rio Oso substations.

Historically, North Valley experiences its highest demand during the summer season; however, a few small areas in the mountains experience highest demand during the winter season. Load forecasts indicate North Valley should reach a Summer Peak demand of 1,031 MW by 2023, assuming load is increasing at approximately 7.8 MW per year.

Accordingly, system assessments in this area included technical studies using load assumptions for these Summer Peak conditions. Table 2.5.3–2 includes load forecast data.

### 2.5.3.2 Area-Specific Assumptions and System Conditions

The North Valley area study was performed consistent with the general study methodology and assumptions described in section 2.3. The ISO-secured Market Participant Portal lists the contingencies that were performed as part of this assessment. Additionally, specific methodology and assumptions that are applicable to the North Valley area study are provided below.

#### Generation

Generation resources in the North Valley area consist of market, qualifying facilities and self-generating units. More than 2,000 MW of hydroelectric generation is located in this area. These facilities are fed from the following river systems: Pit River, Battle Creek, Cow Creek, North Feather River, South Feather River, West Feather River and Black Butt. Some of the large powerhouses on the Pit River and the Feather River watersheds are: Pit, James Black, Caribou, Rock Creek, Cresta, Butt Valley, Belden, Poe and Bucks Creek. The largest generation facility in the area is the natural gas-fired Colusa County generation plant. This plant has a combined total capacity of 717 MW and it is interconnected to the four Cottonwood-Vaca Dixon 230 kV

lines. Table 2.5-7 lists a summary of the generation in the North Valley area, with detailed generation listed in Appendix A.

Table 2.5-7: North Valley area generation summary

<b>Generation</b>	<b>Capacity (MW)</b>
Thermal	1,070
Hydro	1,670
Wind	103
<b>Total</b>	<b>2,843</b>

### Load Forecast

Loads within the North Valley area reflect a coincident peak load for 1-in-10-year forecast conditions for each peak study scenario. Table 2.5-8 shows loads modeled for the North Valley area assessment.

Table 2.5-8: Load forecasts modeled in the North Valley area assessment

<b>1-in-10 Year Non-Simultaneous Load Forecast</b>			
<b>PG&amp;E Area Name</b>	<b>Summer Peak (MW)</b>		
	<b>2014</b>	<b>2017</b>	<b>2022</b>
<b>North Valley</b>	968	992	1,031

### 2.5.3.3 Assessment and Recommendations

The ISO conducted detailed planning assessment based on the study methodology identified in section 2.3 to comply with the Reliability Standard requirements of section 2.2. Details of the planning assessment results are presented in Appendix B. The 2013 reliability assessment of the PG&E North Valley area identified several reliability concerns. These concerns consist of thermal overloads and low voltages under Category A, B and C contingencies. The ISO previously approved capital projects that mitigated most of these reliability concerns for the long-term. The substations identified with high voltages are under review for possible exemption or for some area-wide reactive support.

Until the approved capital projects are completed, operating action plans will be relied upon for mitigation. The ISO will continue to work with PG&E to identify and implement any operating action plans needed prior to the forecast in-service dates of these approved capital projects.

Glenn 230/60 kV Transformer No. 1 Replacement

PG&E submitted this project through the 2013 Request Window per ISO planning standards *Planning for New Transmission vs. Involuntary Load Interruption Standard* (Section VI - 4 reducing load outage exposure through a BCR above 1.0). The project scope is to replace the existing 230/60 kV transformer No. 1 and install a new high side circuit breaker and associated disconnect switches at Glenn Substation.

Glenn Substation is configured in a loop arrangement and supplied by Cottonwood – Glenn and Glenn – Delevan 230 kV lines. Glenn Substation has two 230/60 kV transformers. Transformer No. 2 rated at 175 MVA was installed in 1999. It is operated as a radial transformer bank that serves approximately 129 MW or 24,175 customers at Anita, Capay, Rice, Jacinto, Orland, Willows, Elk Creek, Hamilton and Corning substations. Transformer No. 1 is 53 years old and serves as a redundant transformer during maintenance and emergency conditions. The transformer is rated for 83 MVA, which alone makes it too small to serve the entire area demand.

Currently, there are two concerns for customers served by this station: outage impacts and difficulties in performing maintenance. Transformer No. 2 is the primary facility supplying power into the area. An outage of Transformer No. 2 will result in a sustained outage to all of the 60 kV electric customers served by this substation. As demand continues to increase, performing maintenance on this transformer will be very challenging because the 60 kV system has weak back-ties to the neighboring transmission system. This project will also increase transmission capacity from 175 MVA to 375 MVA. To increase reliability performance for the electric customers served by the Glenn Substation, PG&E submitted this project through the 2013 Request Window to replace the existing 230/60 kV transformer No. 1 and install new high side circuit breaker and associated disconnect switches at Glenn Substation. The ISO determined that the Glenn 230/60 kV Transformer No. 1 Replacement project as needed based on the BCR of 1.54 per ISO Grid Planning Standards, Section VI-4. The project is expected to cost between \$5 million and \$10 million and has an in-service date of May 2018.

## 2.5.4 Central Valley Area

### 2.5.4.1 Area Description

The Central Valley area is located in the eastern part of PG&E's service territory. This area includes the central part of the Sacramento Valley, and it is composed of the Sacramento, Sierra, Stockton and Stanislaus divisions as shown in the figure below.

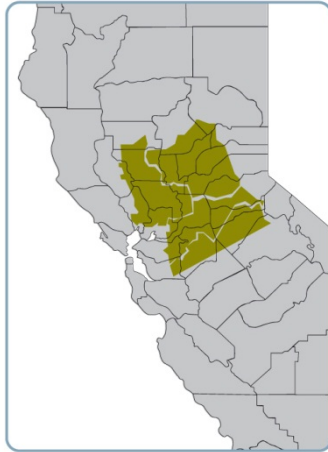

The Sacramento division covers approximately 4,000 square miles of the Sacramento Valley, but excludes the service territory of the Sacramento Municipal Utility District and Roseville. Cordelia, Suisun, Vacaville, West Sacramento, Woodland and Davis are some of the cities in this area. The electric transmission system is composed of 60 kV, 115 kV, 230 kV and 500 kV transmission facilities. Two sets of 230 and 500 kV transmission paths make up the backbone of the system.

The Sierra division is located in the Sierra-Nevada area of California. Yuba City, Marysville, Lincoln, Rocklin, El Dorado Hills and Placerville are some of the major cities located within this area. Sierra's electric transmission system is composed of 60 kV, 115 kV and 230 kV transmission facilities. The 60 kV facilities are spread throughout the Sierra system and serve many distribution substations. The 115 kV and 230 kV facilities transmit generation resources from the north to the south. Generation units located within the Sierra area are primarily hydroelectric facilities located on the Yuba and American River water systems. Transmission interconnections to the Sierra transmission system are from Sacramento, Stockton, North Valley, and the Sierra Pacific Power Company (SPP) in the state of Nevada (Path 24).

Stockton division is located east of the Bay Area. Electricity demand in this area is concentrated around the cities of Stockton and Lodi. The transmission system is composed of 60 kV, 115 kV and 230 kV facilities. The 60 kV transmission network serves downtown Stockton and the City of Lodi. Lodi is a member of the Northern California Power Agency (NCPA), and it is the largest city that is served by the 60 kV transmission network. The 115 kV and 230 kV facilities support the 60 kV transmission network.

Stanislaus division is located between the Greater Fresno and Stockton systems. Newman, Gustine, Crows Landing, Riverbank and Curtis are some of the cities in the area. The transmission system is composed of 230 kV, 115 kV and 60 kV facilities. The 230 kV facilities connect Bellota to the Wilson and Borden substations. The 115 kV transmission network is located in the northern portion of the area and it has connections to qualifying facilities generation located in the San Joaquin Valley. The 60 kV network located in the southern part of the area is a radial network. It supplies the Newman and Gustine areas and has a single connection to the transmission grid via a 115/60 kV transformer bank at Salado.

Historically, the Central Valley experiences its highest demand during the summer season. Load forecasts indicate the Central Valley should reach its Summer Peak demand of 4,366 MW by 2023 assuming load is increasing by approximately 47 MW per year.

Accordingly, system assessments in these areas included technical studies using load assumptions for these Summer Peak conditions. Table 2.5-10 includes load forecast data.

#### 2.5.4.2 Area-Specific Assumptions and System Conditions

The Central Valley area study was performed consistent with the general study methodology and assumptions described in section 2.3. The ISO-secured website lists contingencies that were performed as part of this assessment. Additionally, specific methodology and assumptions that are applicable to the Central Valley area study are provided below.

##### Generation

Generation resources in the Central Valley area consist of market, QFs and self-generating units. The total installed capacity is approximately 3,459 MW with another 530 MW of North Valley generation being connected directly to the Sierra division. Table 2.5-9 lists a summary of the generation in the Central Valley area with detailed generation listed in Appendix A.

Table 2.5-9: Central Valley area generation summary

Generation	Capacity (MW)
Thermal	1,359
Hydro	1,545
Wind	894
Biomass	162
<b>Total</b>	<b>3,960</b>

- Sacramento division — there is approximately 970 MW of internal generating capacity within the Sacramento division. More than 800 MW of the capacity (Lambie, Creed, Goosehaven, EnXco, Solano, High Winds and Shiloh) are connected to the new Birds Landing Switching Station and primarily serves the Bay Area loads.
- Sierra division — there is approximately 1,250 MW of internal generating capacity within the Sierra division, and more than 530 MW of hydro generation listed under North Valley that flows directly into the Sierra electric system. More than 75 percent of this generating capacity is from hydro resources. The remaining 25 percent of the capacity is from QFs, and co-generation plants. The Colgate Powerhouse (294 MW) is the largest generating facility in the Sierra division.
- Stockton division — there is approximately 1,370 MW of internal generating capacity in the Stockton division.
- Stanislaus division — there is approximately 590 MW of internal generating capacity in the Stanislaus division. More than 90 percent of this generating capacity is from hydro

resources. The remaining capacity consists of QFs and co-generation plants. The 333 MW Melones power plant is the largest generating facility in the area.

### Load Forecast

Loads within the Central Valley area reflect a coincident peak load for 1-in-10-year forecast conditions of each peak study scenario. Table 2.5-10 shows loads modeled for the Central Valley area assessment.

Table 2.5-10: Load forecasts modeled in the Central Valley area assessment

<b>1-in-10 Year Non-Simultaneous Load Forecast</b>			
<b>PG&amp;E Area</b>	<b>Summer Peak (MW)</b>		
	<b>2015</b>	<b>2018</b>	<b>2023</b>
<b>Sacramento</b>	1,170	1,205	1,261
<b>Sierra</b>	1,273	1,331	1,424
<b>Stockton</b>	1,303	1,347	1,415
<b>Stanislaus</b>	247	254	266
<b>TOTAL</b>	<b>3,994</b>	<b>4,136</b>	<b>4,366</b>

#### 2.5.4.3 Assessment and Recommendations

The ISO conducted detailed planning assessment based on the study methodology identified in section 2.3 to comply with the Reliability Standard requirements of section 2.2. Details of the planning assessment results are presented in Appendix B.

The 2013 reliability assessment of the PG&E Central Valley area revealed several reliability concerns. These concerns consist of thermal overloads and low voltages under normal, Categories A, B and C contingencies.

- All facilities met the thermal loading performance requirements under normal or Category A conditions. Five facilities were identified with voltage concerns.
- Nine facilities were identified with thermal overloads for Category B performance requirements. Six facilities were identified with low voltage concerns and ten facilities were identified with high voltage deviations.
- Forty-Eight facilities were identified with thermal overloads for Category C performance requirements. Studies also showed 44 facilities with voltage concerns, and 26 facilities with high voltage deviation concerns.



The reliability issues identified in this assessment are very similar to those found in last year's assessment. The previously approved projects within the area address the identified reliability concerns.

Two projects are recommended for approval that PG&E submitted through the 2013 Request Window per ISO planning standards *Planning for New Transmission vs. Involuntary Load Interruption Standard* (Section VI - 4 reducing load outage exposure through a BCR above 1.0).

#### Mosher Transmission Project

PG&E submitted this project through the 2013 Request Window per ISO planning standards *Planning for New Transmission vs. Involuntary Load Interruption Standard* (Section VI - 4 reducing load outage exposure through a BCR above 1.0). The project scope is to reconductor about 12 miles of the Lockeford No. 1 60 kV line, add a circuit breaker and Supervisory Control and Data Acquisition (SCADA) to complete the Mosher 60 kV Ring bus and install a Mosher 60 kV line overload SPS.

The Hammer-Country Club 60 kV line serves approximately 65 MW of load, in San Joaquin County. This line feeds the majority of customers radially through UOP, Mettler and Mosher substations. Mosher Substation alone comprises approximately 12,000 customers (~55 MW). The Mosher 60 kV Bus was partially converted to a ring bus when PG&E added a third 60/12kV transformer. One more circuit breaker needs to be added to complete the ring bus. Because the Hammer-Country Club 60 kV line is normally operated radially, a line outage results in a load loss at Mosher. However, the load at Mosher is automatically restored from the Lockeford No. 1 60 kV line with station automatics.

The Lockeford No. 1 60 kV Line is approximately 11.5 miles long and consists of 2/0 CU, 4/0 AAC, and 715 AAC conductors. The ISO identified that the Lockeford No. 1 60 kV line overloads by 65 percent in 2015 if it serves all of the Mosher Substation following a Hammer-Country 60 kV line outage during summer peak conditions. To increase reliability performance for the electric customers served by Mosher Substation, PG&E submitted this project to reconductor about 12 miles of the Lockeford No. 1 60 kV line, add a circuit breaker and SCADA to complete the Mosher 60 kV ring bus and install Mosher 60 kV line overload SPS. The SPS is needed to prevent overloading of the Stagg and Lockeford systems from serving each other when losing the 230 kV source at either substation during high loading periods. This project, by virtue of connecting Stagg and Lockeford 60 kV systems, also helps mitigate overloads on the Hammer-Country Club 60 kV line under Category C contingencies. The ISO determined that the Mosher Transmission Project as needed based on the BCR of 1.55 per ISO planning standards, Section VI-4. The project is expected to cost between \$10 million and \$15 million and has an in-service date of May 2017.

#### Weber-French Camp 60 kV Line Reconfiguration Project

PG&E submitted this project through the 2013 Request Window per ISO planning standards *Planning for New Transmission vs. Involuntary Load Interruption Standard* (Section VI - 4 reducing load outage exposure through a BCR above 1.0). The project scope is to extend the Weber 60 kV Line No. 1 by 0.2 mile to create two Weber-French Camp 60 kV lines, extend the

Weber 60 kV bus for a new bay, install one 60 kV circuit breaker at Weber Substation and install three 60 kV circuit breakers at French Camp Substation

Weber Substation, in San Joaquin County, is the main source that serves electric customers in the Stockton Area. The Weber 60 kV line No. 1 is one of the 60 kV lines that come from the Weber Substation, which delivers power to approximately 4,700 electric customers. This 60 kV line radially serves French Camp Substation and large load customers such as Cargill, JM Manufacturing and Dana.

Weber 60 kV line No. 1 is comprises approximately 16 miles of multiple conductors that are strung on single wood poles. This line starts at Weber Substation and continues 5 miles to the west to French Camp Substation. Cargill, JM Manufacturing, and Dana substations are tapped along this section of the line. The Weber 60 kV line No. 1 continues west from French Camp Substation for 3 miles, and then it turns to the north for 4 miles before turning east for 4 miles to the Weber Substation. This 11-mile extension of the Weber 60 kV line No. 1 is not electrically connected to French Camp Substation due to normally open line switches. To increase reliability performance for the electric customers served by Weber 60 kV line No. 1, PG&E submitted this project through the 2013 Request Window to create a second source to the French Camp substation. The ISO determined that the Weber-French Camp 60 kV Line Reconfiguration Project as needed based on the BCR of 1.04 per ISO Grid Planning Standards, Section VI-4. The project is expected to cost between \$7 million and \$8.4 million and has an in-service date of December 2016.

In addition, two load interconnection projects were submitted by PG&E through the 2013 Request Window.

#### *Stockton A-Lockeford-Bellota Load Interconnection*

In addition to the projects identified above as recommended for approval, the ISO concurs with the load interconnection project submitted by PG&E to facilitate the interconnection of the customer owned substation tapped into PG&E's Stockton 'A' – Lockeford – Bellota #1 115 kV Line.

#### *Stagg No. 1 Load Interconnection*

In addition to the projects identified above as recommended for approval, the ISO concurs with the load interconnection project submitted by PG&E to facilitate the interconnection of the customer owned substation to PG&E's Stagg #1 60 kV tap line.

## 2.5.5 Greater Bay Area

### 2.5.5.1 Area Description

The Greater Bay Area (or Bay Area) is at the center of PG&E's service territory. This area includes Alameda, Contra Costa, Santa Clara, San Mateo and San Francisco counties as shown in the adjacent illustration. To better conduct the performance evaluation, the area is divided into three sub-areas: East Bay, South Bay and San Francisco-Peninsula.



The East Bay sub-area includes cities in Alameda and Contra Costa counties. Some major cities are Concord, Berkeley, Oakland, Hayward, Fremont and Pittsburg. This area primarily relies on its internal generation to serve electricity customers.

The South Bay sub-area covers approximately 1,500 square miles and includes Santa Clara County. Some major cities are San Jose, Mountain View, Morgan Hill and Gilroy. Los Esteros, Metcalf, Monta Vista and Newark are the key substations that deliver power to this sub-area. The South Bay sub-area encompasses the De Anza and San Jose divisions and the City of Santa Clara. Generation units

within this sub-area include Calpine's Metcalf Energy Center, Los Esteros Energy Center, Calpine Gilroy Power Units, and SVP's Donald Von Raesfeld power plant. In addition, this sub-area has key 500 kV and 230 kV interconnections to the Moss Landing and Tesla substations.

Last, the San Francisco-Peninsula subarea encompasses San Francisco and San Mateo counties, which include the cities of San Francisco, San Bruno, San Mateo, Redwood City, and Palo Alto. The San Francisco-Peninsula area presently relies on transmission line import capabilities that include the Trans Bay Cable to serve its electricity demand. Electric power is imported from Pittsburg, East Shore, Tesla, Newark and Monta Vista substations to support the sub-area loads.

The Trans Bay Cable Project became operational in 2011. It is a unidirectional, controllable, 400 MW HVDC land and submarine-based electric transmission system. The project employs voltage source converter technology, which will transmit power from the Pittsburg 230 kV substation in the city of Pittsburg to the Potrero 115 kV substation in the city and county of San Francisco.

In addition, the re-cabling of the Martin-Bayshore-Potrero lines (A-H-W #1 and A-H-W #2 115 kV cable) replaced the two existing 115 kV cables between Martin-Bayshore-Potrero with new cables and resulted in increased ratings on these facilities. The new ratings provided by this project will increase transmission capacity between Martin-Bayshore-Potrero and relieve congestion.

### 2.5.5.2 Area-Specific Assumptions and System Conditions

The Greater Bay Area study was performed consistent with the general study assumptions and methodology described in section 2.3. The ISO-secured participant portal provides more details of contingencies that were performed as part of this assessment. In addition, specific assumptions and methodology to the Greater Bay Area study are provided below in this section.

#### Generation

Table 2.5-11 lists a summary of the generation in the Greater Bay area, with detailed generation listed in Appendix A.

Table 2.5-11: Greater Bay area generation summary

<b>Generation</b>	<b>Capacity (MW)</b>
Thermal	7938
Wind	335
Biomass	13
<b>Total</b>	<b>8286</b>

#### Load Forecast

Loads within the Greater Bay Area reflect a coincident peak load for 1-in-10-year forecast conditions. Table 2.5-12 and Table 2.5-13 show the area load levels modeled for each of the PG&E local area studies, including the Greater Bay Area.

Table 2.5-12: Summer Peak load forecasts for Greater Bay Area assessment

<b>1-in-10 Year Non-Simultaneous Load Forecast</b>			
<b>PG&amp;E Area</b>	<b>Summer Peak (MW)</b>		
	<b>2015</b>	<b>2018</b>	<b>2023</b>
<b>East Bay</b>	958	977	1,010
<b>Diablo</b>	1,655	1,672	1,706
<b>San Francisco</b>	971	992	1,026
<b>Peninsula</b>	985	1,006	1,045
<b>Mission</b>	1,369	1,398	1,458
<b>De Anza</b>	975	1,002	1,035
<b>San Jose</b>	1,887	1,937	2,012
<b>TOTAL</b>	8,800	8,984	9,292

Table 2.5-13: Winter Peak load forecasts for San Francisco and Peninsula Area assessments

<b>1-in-10 Year Non-Simultaneous Load Forecast</b>			
<b>PG&amp;E Area</b>	<b>Winter Peak (MW)</b>		
	<b>2015</b>	<b>2018</b>	<b>2023</b>
<b>San Francisco</b>	886	904	933
<b>Peninsula</b>	967	987	1,024

### **2.5.5.3 Assessment and Recommendations**

The ISO conducted a detailed planning assessment based on the study methodology identified in section 2.3 to comply with the Reliability Standard requirements of section 2.2. Details of the planning assessment results are presented in Appendix B. The 2012 reliability assessment of the PG&E Greater Bay Area has identified several reliability concerns. These concerns consist of thermal overloads under Category B and C contingencies. To address the identified thermal

overloads and low voltage concerns, the ISO recommends the following transmission development projects as a part of the mitigation plan.

Morgan Hill Area Reinforcement

The project is a new 230/115 kV substation in East Morgan Hill. This would be located close to the Metcalf-Moss Landing 230 kV corridor with one new 230/115 kV transformer installed at the new substation. In addition, the Morgan Hill-Llagas 115 kV and Metcalf-Moss Landing No. 2 230 kV Lines should be looped into the 115 kV and 230 kV buses, respectively. A short portion of the Morgan Hill-Llagas 115 kV Line will also be reconductored.

This project is recommended to increase the reliability of the Morgan Hill area by adding a new source into the area. The new 115 kV source will avoid potential electric load interruptions for most of the Morgan Hill and Gilroy area, following the loss of the Metcalf-Morgan Hill and Metcalf-Llagas 115 kV double circuit tower line. In addition, completing this project will mitigate overloads under various other Category C contingencies. The project is estimated to cost \$35 to \$45 million and has an in-service date of May 2021.

BART Berryessa Extension Project

In addition to the project identified above as recommended for approval, the ISO concurs with the load addition project submitted by PG&E to facilitate the interconnection of two new loads into the PG&E 115 kV system in east San Jose.

San Francisco Peninsula Reliability Concerns

Within the 2013-2014 transmission planning process the ISO continued to assess the reliability need of the San Francisco Peninsula, to further address the reliability concern in supply to the downtown San Francisco area due to an extreme event as defined by the reliability standards. The reliability standards require the ISO to assess the impacts of extreme events; however they do not mandate that the consequences be mitigated – the need for mitigations is based on the specific circumstances by the responsible planning entities. The reliability assessment therefore focuses on whether the specific risks and circumstances regarding the San Francisco Peninsula warrant mitigation measures beyond the minimum prescribed by mandatory reliability standards and the effectiveness of various proposed solutions in mitigating the identified risks. The reliability assessment is included in Appendix D of this transmission plan.

The ISO assessment has determined that there are unique circumstances affecting the San Francisco area that form a credible basis for considering mitigations of risk of outages and of restoration times that are beyond the minimum reliability standards. The Peninsula area does have unique characteristics in the western interconnection due to the urban load center, geographic and system configuration, and potential risks with challenging restoration times for these types of events.

Further, the analysis concluded that in the event that additional transmission system reinforcement is considered necessary, the addition of a new 230 kV transmission line from Morago substation to Potrero substation would be the preferred mitigation plan to further manage the risks of an extreme event in the San Francisco Peninsula area.

However, the ISO has determined that further analysis of the reliability risks and the benefits that potential reinforcement options would have in reducing those risks is needed. The ISO plans to undertake this analysis this year and may bring forward a recommendation for ISO Board approval as an addendum to this plan or in the next planning cycle as part of the 2014-2015 Transmission Plan.

## 2.5.6 Greater Fresno Area

### 2.5.6.1 Area Description

The Greater Fresno Area is located in the central to southern PG&E service territory. This area includes Madera, Mariposa, Merced and Kings counties, which are located within the San Joaquin Valley Region. The adjacent figure depicts the geographical location of the Fresno area.



The Greater Fresno area electric transmission system is composed of 70 kV, 115 kV and 230 kV transmission facilities. Electric supply to the Greater Fresno area is provided primarily by area hydro generation (the largest of which is Helms Pump Storage Plant), several market facilities and a few qualifying facilities. It is supplemented by transmission imports from the North Valley and the 500 kV lines along the west and south parts of the Valley. The Greater Fresno area is composed of two primary load pockets including the Yosemite area in the northwest portion of the shaded region in the adjacent figure. The rest of the shaded region represents the Fresno area.

The Greater Fresno area interconnects to the bulk PG&E transmission system by 12 transmission circuits. These consist of nine 230 kV lines; three 500/230 kV banks; and one 70 kV line, which are served from the Gates substation in the south, Moss Landing in the west, Los Banos in the northwest, Bellota in the northeast, and Templeton in the southwest. Historically, the Greater Fresno area experiences its highest demand during the summer season but it also experiences high loading because of the potential of 900 MW of pump load at Helms Pump Storage Power Plant during off-peak conditions. Load forecasts indicate the Greater Fresno area should reach its summer peak demand of approximately 3,662 MW in 2023, which includes losses and pump load. This area has a maximum capacity of about 3,987 MW of local generation in the 2023 case. The largest generation facility within the area is the Helms plant, with 1,212 MW of generation capability. Accordingly, system assessments in this area include the technical studies for the scenarios under summer-peak and off-peak conditions that reflect different operating conditions of Helms.

### 2.5.6.2 Area-Specific Assumptions and System Conditions

The Greater Fresno area study was performed consistent with the general study assumptions and methodology described in section 2.3. The ISO-secured website provides more details of contingencies that were performed as part of this assessment. In addition, specific assumptions and methodology that applied to the Fresno area study are provided below.



## Generation

Generation resources in the Greater Fresno area consist of market, QFs and self-generating units. Table 2.5-14 lists a summary of the generation in the Greater Fresno area with detailed generation listed in Appendix A.

Table 2.5-14: Greater Fresno area generation summary

<b>Generation</b>	<b>Capacity (MW)</b>
Thermal	1,304
Hydro	2,475
Solar	130
Biomass	78
<b>Total</b>	<b>3,987</b>

## Load Forecast

Loads within the Fresno and Yosemite area reflect a coincident peak load for 1-in-10-year forecast conditions for each peak study scenario. Table 2.5-15 shows the substation loads assumed in these studies under Summer Peak conditions.

Table 2.5-15: Load forecasts modeled in Fresno and Yosemite area assessment

<b>1-in-10 Year Non-Simultaneous Load Forecast</b>			
<b>PG&amp;E Area Name</b>	<b>Summer Peak (MW)</b>		
	<b>2015</b>	<b>2018</b>	<b>2023</b>
<b>Yosemite</b>	852	860	875
<b>Fresno</b>	2,327	2,411	2,557

### **2.5.6.3 Assessment and Recommendations**

The ISO conducted detailed planning assessment based on the study methodology identified in section 2.3 to comply with the Reliability Standard requirements of section 2.3. Details of the planning assessment results are presented in Appendix B. The ISO study of the Fresno area yielded the following conclusions:

- one overload would occur under normal conditions for Summer Peak;
- one overload would be caused by critical single contingencies under Summer Peak conditions; and
- multiple overloads caused by critical multiple contingencies would occur under Summer Peak and Off-Peak conditions.

The ISO proposed solutions to address the identified overloads and received 3 project proposals from PG&E through the 2013 Request Window. For projects where the expected in-service date is beyond the identified reliability driven need date, the ISO will continue to work with PG&E to develop operational action plans in the interim.

To address the identified thermal overloads and low voltage concerns in the area, the ISO recommends the following transmission development projects as a part of the mitigation plan.

#### *Kearney-Kerman 70kV Reconductor*

PG&E submitted this project through the 2013 Request Window per ISO *Planning Standards for New Transmission vs. Involuntary Load Interruption Standard* (Section VI - 4, for reducing load outage exposure through a BCR above 1.0). The project scope includes reconductoring 11 miles of limiting conductor on the Kearney-Kerman 70 kV line and upgrading equipment to achieve Summer Emergency rating of greater than 700 Amps.

The Kearney-Kerman 70 kV line is located in Fresno County. A 230 kV source at Kearney provides power to customers at Fresno Waste Water substation and serves as a back-tie to Kerman substation. The line is approximately 11 miles long, of which 10.75 miles is made up of 3/0 CU, while the remaining 0.13 miles is 715.5 AAC. Kerman substation is normally fed from the Helm substation source via the Helm-Kerman 70 kV Line. The 3/0 CU section of the Kearney-Kerman 70 kV line is expected to overload sometime around 2014 when Kerman substation is fed from the Kearney source under emergency conditions after the loss of the Helm-Kerman 70 kV Line and Fresno Waste Water Unit #1 is off line. As an interim solution, Operations has implemented a summer operating setup for Kerman substation, which is accomplished by opening switch 87 at Kerman and splitting the 70 kV bus. The interim setup will not allow Kerman substation load to be automatically restored for transmission outages and thus is not a long term solution.

The ISO has determined that this project is needed based on a BCR of 1.4. This meets the ISO planning standard Section VI, Part 4 requirements. This project is expected to cost between \$12 million and \$18 million with an in-service date of May 2018.

#### *McCall-Reedley #2 115kV Line*

The project scope is to build a new McCall-Reedley #2 115 kV line with conductor sized to handle at least 825 Amps Summer Normal and 975 Amps Summer Emergency. The ISO

recommendation, consistent with PG&E's submission, is to construct the new line as a double circuit and transfer the existing McCall-Reedley #1 115 kV line on to the new double circuit to take advantage of existing rights-of-way and permitting. Both the McCall and Reedley substations will need one bay position for the new terminations.

Reedley and Wahtoke substations are located in the southern portion of Fresno County and serve (directly and indirectly) roughly 44,749 customers. Reedley Substation currently has three 115 kV sources, including the McCall-Reedley, Sanger-Reedley and Kings River-Sanger-Reedley transmission lines. Wahtoke Substation is looped off the existing McCall-Reedley 115 kV line with one circuit switcher and motor operated air switch. The load served by these three transmission lines is forecasted to reach roughly 175 MW by 2023.

Planning analysis has shown that the combined outage of two of the three lines serving the Reedley and Wahtoke areas will cause an emergency overload of the remaining 115 kV line. The worst outage is an outage of the Sanger-Reedley line in combination with the McCall-Reedley (McCall-Wahtoke section). This will cause an overload on the Kings River-Sanger-Reedley line of up to 155 percent of its Summer Emergency rating, in addition to creating low voltage conditions. Building a new 115 kV line from McCall will provide Reedley substation with the added transmission capacity needed to mitigate thermal loading and voltage violations seen for the loss of two sources to the area.

The ISO has determined that this project is needed to mitigate Category C violations. It is expected to cost between \$25 million and \$40 million with an in-service date of May 2019.

#### Reedley 115/70kV Transformer Capacity Increase

The project scope is expected to be completed in two phases. The first phase involves replacing limiting terminal equipment on the Reedley #2 117/70 kV transformer to achieve the full bank rating. The second phase involves rerating the Reedley #4 115/70 kV transformer Summer Emergency rating and replacing Reedley #2 115/70 kV transformer with a 180 MVA bank.

The Reedley 70 kV system is comprised of Dinuba, Orosi, Stone Corral, Sand Creek, Dunlap, and Tivy Valley substations, and is located in the North West portion of Tulare County. The above mentioned 70 kV substations are radially served from Reedley via two 115/70 kV transformers, one 4x1ph 30 MVA units (90 MVA 3ph), and 1x3ph 100 MVA unit, transformers No. 2 and No. 4, respectively. Transformer No. 2 (1952 vintage) currently has a Summer Normal and Summer Emergency rating of 83 MVA and 96 MVA, respectively, due to limiting terminal equipment. If the limiting terminal equipment were to be replaced the bank could have ratings of 90 MVA and 108 MVA, respectively. Transformer No. 4 (2004 vintage) currently has a Summer Normal and Summer Emergency rating of 100 MVA and 110 MVA, respectively. Additionally, Dinuba Energy, a 9.9 MVA generator, is also served by Reedley on the Reedley-Dinuba 70 kV line.

The recorded Reedley 70 kV load in 2013 peaked at 95.2 MW on July 2 at around 19:00. During this same time period, Dinuba Energy was observed as being off line. If an outage of the Reedley 115/70 kV Transformer No. 4 had occurred the forecasted loading on the remaining Transformer No. 2 would have been roughly 99 percent of its Summer Emergency rating.

PG&E's Distribution Planning forecast for this area (inclusive of all six substations listed above) has forecasted a 1.9 MW/year growth rate. At this growth rate it is estimated that the Reedley 70 kV area load will reach 108 MVA by 2017 and 110 MVA by 2018. Therefore, under NERC Category C contingencies of either parallel 115/70 kV transformer, in addition to Dinuba Energy generator being off line, an overload of the remaining transformer is anticipated. Because of the age of bank No. 2 (1952 vintage), it is recommended to replace these single phase transformers first while requesting a custom emergency rating for the newer bank No. 4 (2004 vintage), which will be sufficient to serve the forecasted 70 kV load until 2023.

The ISO has determined that this project is necessary to mitigate Category B contingencies based on actual substation readings from PG&E. It is expected to cost between \$12 million and \$18 million with a phase one in-service date of May 2015 followed by a phase two in-service date of May 2018 or earlier.

In addition, two load interconnection projects were submitted by PG&E through the 2013 Request Window.

*Gill Ranch 115 kV Tap Load Interconnection*

In addition to the projects identified above as recommended for approval, the ISO concurs with the load interconnection project submitted by PG&E to facilitate the interconnection of the customer owned substation to PG&E's Gill Ranch 115 kV tap line.

*Sanger-Reedley Tap Load Interconnection*

In addition to the projects identified above as recommended for approval, the ISO concurs with the load interconnection project submitted by PG&E to facilitate the interconnection interconnect a new load customer to PG&E's Sanger – Reedley 115 kV Line, via a new 1.25 mile transmission line extension to the Project substation.

## 2.5.7 Kern Area

### 2.5.7.1 Area Description

The Kern area is located south of the Yosemite-Fresno area and north of SCE's service territory. Midway substation, one of the largest substations in the PG&E system is located in the Kern area and has connections to PG&E's Diablo Canyon, Gates and Los Banos substations as well as SCE's Vincent substation. The figure below depicts the geographical location of the Kern area.

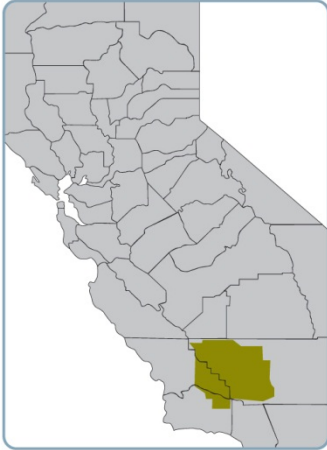

The bulk of the power that interconnects at Midway substation transfers onto the 500 kV system. A substantial amount also reaches neighboring transmission systems through Midway's 230 kV and 115 kV interconnections. These interconnections include 230 kV lines to Yosemite-Fresno (north) as well as 115 and 230 kV lines to Los Padres (west). Electric customers in the Kern area are served primarily through the 230/115 kV transformers at Midway and Kern power plant substations and through local

generation power plants connected to the lower voltage transmission network.

Load forecasts indicate that the Kern area should reach its summer peak demand of 2,385 MW in 2023, which includes losses and pump load. Accordingly, system assessments in this area include the technical studies for the scenarios under these load assumptions for Summer Peak conditions.

### 2.5.7.2 Area-Specific Assumptions and System Conditions

The Kern area study was performed in a manner consistent with the general study methodology and assumptions described in section 2.3. The ISO-secured website lists the contingencies that were studied as part of this assessment. In addition, specific assumptions and methodology that applied to the Kern area study are provided in this section.

#### Generation

Generation resources in the Kern area consist of market, qualifying facilities and self-generating units. Table 2.5-16 lists a summary of the generation in the Kern area with detailed generation listed in Appendix A.

Table 2.5-16: Kern area generation summary

<b>Generation</b>	<b>Capacity (MW)</b>
Thermal	3,176
Hydro	22
Solar	189
Biomass	56
<b>Total</b>	<b>3,443</b>

### Load Forecast

Loads within the Kern area reflect a coincident peak load for 1-in-10-year forecast conditions for each peak study scenario. Table 2.5-17 shows loads in the Kern area assessment.

Table 2.5-17: Load forecasts modeled in the Central Valley area assessment

<b>1-in-10 Year Non-Simultaneous Load Forecast</b>			
<b>PG&amp;E Area Name</b>	<b>Summer Peak (MW)</b>		
	<b>2014</b>	<b>2017</b>	<b>2022</b>
<b>Kern</b>	1,859	1,910	2,006

### 2.5.7.3 Assessment and Recommendations

The ISO conducted detailed planning assessment based on the study methodology identified in section 2.3 to comply with the Reliability Standard requirements of section 2.2. Details of the planning assessment results are presented in Appendix B. The ISO study of the northern Kern area yielded the following conclusions:

- no overloads and no voltage concerns would occur under normal conditions;
- one overload and two low voltage concerns would occur for Category B contingencies; and
- multiple overloads and low voltage concerns caused by Category C contingencies would occur under all studied conditions.

The ISO proposed solutions to address the identified overloads received five project proposals from PG&E through the 2013 Request Window. For projects where the expected in-service

date is beyond the identified performance requirements, the ISO will continue to work with PG&E to develop operational action plans in the interim.

In addition to the studies conducted as a part of the reliability assessment, which used a combined coincident peak of both the Fresno and Kern planning areas, studies were separately conducted for the Kern area coincident peak. Using a base case with the combined coincident peak does not adequately reflect the loading in the Kern area as it peaks at a different time than the Fresno area. The assessment of the Kern coincident loading increase the constraints identified in the Kern area.

To address the identified thermal overloads and low voltage concerns in the area, the ISO recommends the following transmission development projects as part of the mitigation plan.

#### Midway-Kern PP #2 230kV Line

The project scope is to unbundle and reconductor the Midway-Kern PP #1 230 kV line into two circuits, as well as looping Bakersfield off either one of the Midway-Kern PP #1 or #2 230 kV lines, as well as relocating the Stockdale 230 kV taps to the Kern PP 230 kV substation.

This project protects against Category B and C contingencies, as well as the ISO planning standards for combined line and generator outage violations. In addition, it is required to meet the ISO *Planning Standard for New Transmission vs. Involuntary Load Interruption* (Section VI, part 2).

Kern PP is located in the city of Bakersfield within Kern County. Kern PP is served by the Midway substation via three 230 kV lines: the Midway Kern #1; Midway Kern #3; and Midway Kern #4. The Midway-Kern #1 230 kV line comprises parallel conductors on each side of double circuit lattice steel towers, tied together (bundled) at regular intervals for the majority of the 21 miles. The Bakersfield substation is tapped off the Kern #1 and #4 230 kV lines, while the Stockdale substation is tapped off the Kern #1 and #3 230 kV lines. Both substations operate as a flip-flop for the loss of either source.

The Bakersfield substation serves roughly 35,940 customers in the urban Bakersfield area. Between May and September 2012, the Bakersfield substation load exceeded 100 MW for a total of 64 hours. The Stockdale substation serves roughly 47,192 customers in the urban Bakersfield area. Between May and September 2012, the substation load exceeded 100 MW for a total of 15 hours. Because the Bakersfield and Stockdale 230 kV substations are operated as flip-flops and their load levels have historically exceeded 100 MW, this project proposes to loop both stations as required by the ISO's Transmission Planning Standard VI-2, which specifies that "single substations of 100 MW or more should be served through a looped system". The project includes increasing transmission capacity between Midway and Kern PP as identified in the reliability assessment.

The load served by the Midway-Kern 230 kV lines in 2013 was recorded during the summer peak at 1,151 MW. The original loading in the base case for the coincident loading of the Fresno and Kern area had modeled the load at 942 MW. As a part of an internal PG&E study, the Kern Area Long Term Study (LTS) focused on the Kern transmission system and modeling accurate load levels for smaller local area peak conditions. The planning assessment used the higher

load for the Kern area than originally studied for the coincident loading of the Fresno and Kern area.

Planning analysis identified for Category B and C contingencies that the Midway-Kern #1, #3, and #4 overload was above their Summer Emergency rating. The worst Category B contingency is the loss of the Midway-Kern PP #1 line. For this outage the Midway-Kern PP #3 230 kV line is forecasted to reach 101 percent of its Summer Emergency rating in 2023. The worst Category C contingency is the loss of the Midway-Kern PP #1 and the Kern PP-Kern Front 115 kV line. For this outage the Midway-Kern PP #3 line is forecasted to reach 122% of its Summer Emergency rating by 2023. Splitting the Midway-Kern PP #1 230 kV line into two circuits effectively uses existing infrastructure and rights-of-way to alleviate the capacity constraints for single and multiple element outages on the imports to Kern PP 230 kV from Midway 230kV. The special protection schemes approved in the 2012-2013 transmission plan as a part of the Kern 230 kV Area Reinforcement will mitigate concerns with the Category C5 contingencies of the Midway-Kern PP 230 kV lines; however, the special protection schemes proposed will not cover the Category B and C3 contingencies identified in this reliability assessment.

The ISO has determined that this project is needed to mitigate Category C violations. The project is expected to cost between \$60 million and \$90 million with an in-service date of May 2019.

#### Wheeler Ridge Junction Station

The project scope is to build a new 230/115 kV substation at Wheeler Ridge Junction using mostly existing right-of-way accesses to connect to the Stockdale 230 kV substation and convert the existing Wheeler Ridge-Lamont 115 kV to 230kV operation, which provides a third 230 kV source to Wheeler Ridge Junction substation. This project is dependent on the recommended Midway-Kern PP #2 230 kV Line project identified above being approved.

Kern PP is located in the city of Bakersfield within Kern County. Kern PP is served by the Midway substation via three 230 kV lines: the Midway Kern #1; Midway Kern #3; and Midway Kern #4. Kern PP serves demand mainly on the 115 kV system, which extends to the north, south, and east of the substation and is operated on a radial during summer months. Three 420 MVA 3-phase 230/115 kV transformers provide the source for the 115 kV system; terminal equipment is currently limiting two of the three transformers below their bank summer normal and emergency ratings. The 115 kV substations served via the Kern-Tevis-Stockdale-Lamont and Kern-Tevis-Stockdale lines and are operated on flip-flop during non-summer months and radial during the summer months due to capacity limitations. Additionally, the 115 kV line from Wheeler Ridge to Lamont is normally kept open at Wheeler Ridge to address concerns with through flow for 230 kV line outages.

The planning analysis of the Kern area coincident peak loading identified the Category B contingency of combined line and generator contingencies and Category C contingency multiple facility thermal overloads. The worst Category C contingency is the loss of the Westpark-Magunden and the Lerdo-Famoso 115 kV line. For this outage, the Kern-Magunden-Witco line is forecasted to reach 116 percent of its summer emergency rating by 2023. Adding the Wheeler Ridge Junction station and the new 115 kV line to Magunden alleviates the capacity



constraints for single and multiple element outages on the 115 kV lines serving the Westpark, Magunden, and Columbus substations. Additionally, adding the new 230/115 kV station reduces the loading on the capacity constrained Kern PP 230/115 kV transformers and eliminates overloads on the Midway-Wheeler Ridge 230 kV lines for Midway 230 kV bus 1D and 2D outages.

The ISO has determined that this project is needed to mitigate Category B and C contingencies as well as the combined line and generator outages under the CAISO Planning Standard. The project is expected to cost between \$90 million and \$140 million with an in-service date of May 2020.

#### San Bernard-Tejon 70kV Reconductor

PG&E submitted this project through the 2013 Request Window per ISO *Planning Standard for New Transmission vs. Involuntary Load Interruption Standard* (Section VI, part 4, for reducing outage exposure through a BCR above 1.0).

The project scope is to reconductor 7 miles of the San Bernard-Tejon 70 kV line with conductor capable of at least 631 Amps Summer Normal rating and at least 742 Amps Summer Emergency rating.

The San Bernard-Tejon 70 kV line delivers power to the Tejon substation including five large load electric customers that are directly connected to the transmission system. Those customers are Pacific Pipeline, Grapevine, Rose, Castaic, and Lebec.

In June 2012 a second 70/12 kV 30 MVA transformer bank at Tejon substation was installed as a part of a PG&E distribution system capacity increase project. Updated demand forecasts were provided by PG&E's Distribution Planning department to account for the additional load increase anticipated for the increased distribution capacity.

In using the updated demand forecast for Tejon Substation, the San Bernard-Tejon 70 kV line is forecasted to overload up to 110 percent of its summer emergency rating in 2014 resulting from an outage of the Wheeler Ridge-Tejon line or a Bus D fault on the Wheeler 70 kV bus.. In the interim, PG&E's Operations Engineering has implemented a seasonal setup by normally opening the San Bernard-Tejon 70 kV line to mitigate the concerns identified here. This seasonal setup is not recommended for long term operations as it exposes the customers served via the Wheeler Ridge-Tejon 70 kV line to an increased amount of sustained outages.

The ISO has determined that this project is needed based on a BCR of 1.06. The project is expected to cost between \$8 million and \$12 million with an in-service date of May 2018.

#### Taft-Maricopa 70kV Line Reconductor

PG&E submitted this project through the 2013 Request Window per ISO *Planning Standard for New Transmission vs. Involuntary Load Interruption Standard* (Section VI, part 4, for reducing outage exposure through a BCR above 1.0).

The project scope is to replace the conductor on the Taft-Maricopa 70 kV line with a conductor capable of at least 631 amps during Summer Normal and at least 742 amps during Summer Emergency conditions. This project is needed to meet load growth under emergency conditions.

The Taft-Maricopa 70 kV line is located in Kern County and is approximately 6 miles long. About 3.45 miles are made up of 3/0 CU while the remaining 2.45 miles is 397.5 AAC. A 115 kV source at Taft provides power to a number of large load customers on the 70 kV system in addition to PG&E distribution load at Maricopa, Carneras, Cuyama, and Copus substations. Two cogeneration customers are connected off the Taft-Maricopa 70 kV line: Solar Tannehill and Cadet.

PG&E's Copus bank 1 is normally fed from Taft substation via the Taft-Maricopa line, while Copus bank 2 is normally fed from Old River substation. This arrangement is part of a seasonal operating setup to mitigate overload concerns on the Kern-Old River No. 1 70 kV line, which normally calls for opening switch 61 at Copus substation. It is expected that upon completion of the Kern-Old River #1 and #2 reconductor project, Copus substation will normally be entirely served from Old River substation.

On July 25, 2013 the Taft-Maricopa 70 kV line peaked at 35 MVA (89 percent of its summer normal rating). At the same time, Copus Bank 2 was served from Old River and was loaded to 9.8 MVA, while Solar Tannehill and Cadet Cogeneration facilities were offline. If the Old River-Copus 70 kV line was to be opened and Copus Bank 2 transferred to the Taft 70 kV source, the loading on the Taft-Maricopa 70 kV line is expected to reach 44.8 MVA (98percent of its summer emergency rating). A new customer load (Plains All American Pipeline) on the distribution system fed from Copus substation is expected to connect in October 2014. This load is forecasted to be 3 MW for 2014. With this added load at the Copus substation, the Taft-Maricopa 70 kV line is forecasted to reach 107 percent of its summer emergency rating in 2014 while serving all of Copus substation. Therefore, to reliably serve the Copus substation during these outage conditions, it is recommended to increase the capacity of the Taft-Maricopa 70 kV line by re-conductoring roughly 6 miles of limiting conductor.

The ISO has determined that this project is needed based on a BCR of 1.05. The project is expected to cost between \$6 million and \$10 million with an in-service date of May 2018.

#### Wheeler Ridge-Weedpatch 70kV Reconductor

The project scope includes reconductoring 15 miles of the Wheeler Ridge-Weedpatch 70 kV line with a conductor capable of at least 631 amps during Summer Normal and at least 742 amps during Summer Emergency conditions. Associated terminal equipment is to be upgraded as necessary to achieve the desired conductor rating.

Wheeler Ridge Substation is located in Kern County and delivers electric power to the southeastern border of the utility's service territory via Wheeler Ridge 230/70 and 115/70 kV transformer banks. Specifically, Wheeler Ridge delivers power to over 15,000 electric customers that are interconnected to a 70 kV system, which is composed of the following substations: Weedpatch, Wellfield, Tejon, San Bernard, Lakeview, and Arvin. The Wheeler Ridge 70 kV system also delivers power to several large load electric customers that are directly connected to the transmission system. These large load electric customers include: Pacific Pipeline, Grapevine, Rose, Castaic, Lebec, Emidio, Texaco Emidio, Pacific Pipeline Emidio, Kelley, Sycamore, and Rio Bravo Hydro substations.

This project protects against a Category C contingency. When the hydro units Rio Bravo Hydro and Kern Canyon PH are off line (no water running through them), there is an overload on the Wheeler Ridge – Weedpatch line. During this outage, the Weedpatch – San Bernard 70 kV line, which is a back feed to Weedpatch substation, does not have enough capacity to serve the load and so it is normally open, which results in overloading the Wheeler Ridge – Weedpatch line. The Rio Bravo Hydro and Kern Canyon PH are run-of-river hydro units that are not dispatchable; therefore, during low water scenarios, normal overloads are forecasted for the Wheeler Ridge-Weedpatch 70 kV line.

In the interim, a temporary shoofly was installed by PG&E in June 2013 to address the normal overload seen on the Wheeler Ridge – Weedpatch line.

The ISO has determined that this project is needed to mitigate Category A and C violations. The project is expected to cost between \$15 million and \$25 million with an in-service date of May 2018.

## 2.5.8 Central Coast and Los Padres Areas

### 2.5.8.1 Area Description

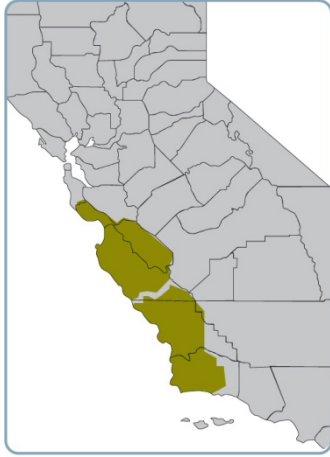

The PG&E Central Coast division is located south of the Greater Bay Area and extends along the Central Coast from Santa Cruz to King City. The green shaded portion in the figure below depicts the geographic location of the Central Coast and Los Padres areas.

The Central Coast transmission system serves Santa Cruz, Monterey and San Benito counties. It consists of 60 kV, 115 kV, 230 kV and 500 kV transmission facilities. Most of the customers in the Central Coast division are supplied via a local transmission system out of the Moss Landing Power Plant Substation. Some of the key substations are Moss Landing, Green Valley, Paul Sweet, Salinas, Watsonville, Monterey, Soledad and Hollister. The local transmission systems are the following: Santa Cruz-Watsonville, Monterey-Carmel and Salinas-Soledad-Hollister sub-areas, which are supplied via 115 kV double circuit tower lines. King City, also in this area, is supplied by 230 kV lines from the Moss Landing and Panoche substations, and Burns-Point Moretti sub-area that is supplied by a 60 kV line from the Monta Vista Substation in Cupertino. Besides the 60 kV transmission system interconnections between Salinas and Watsonville substations, the only other interconnection among the sub-areas is at the Moss Landing substation. The Central Coast transmission system is tied to the San Jose and De Anza systems in the north and the Greater Fresno system in the east. The total installed generation capacity is 2,900 MW, which includes the 2,600 MW Moss Landing Power Plant.

The PG&E Los Padres division is located in the southwestern portion of PG&E's service territory (south of the Central Coast division). Divide, Santa Maria, Mesa, San Luis Obispo, Templeton, Paso Robles and Atascadero are among the cities in this division. The city of Lompoc, a member of the Northern California Power Authority (NCPA), is also located in this area. Counties in the area include San Luis Obispo and Santa Barbara. The 2,400 MW Diablo Canyon Nuclear Power Plant (DCPP) is also located in Los Padres. Most of the electric power generated from DCPP is exported to the north and east of the division through 500 kV bulk transmission lines, so it has very little impact on the Los Padres division operations. There are several transmission ties to the Fresno and Kern systems with the majority of these interconnections at the Gates and Midway substations. Local customer demand is served through a network of 115 kV and 70 kV circuits. The total installed generation capacity is 1,630 MW including the 680 MW Morro Bay Power Plant and recently installed photovoltaic solar (PV) generation resources, which includes the 550 MW TOPAZ and 250 MW California Valley Solar facilities. The total installed capacity does not include the 2,400 MW DCPP output as it does not serve the Los Padres division.

Load forecasts indicate that the Central Coast and Los Padres areas summer peak demand will be 770 MW and 580 MW, respectively, by 2018. By 2023, the summer peak loading for Central Coast and Los Padres would be 803 MW and 605 MW, respectively. Winter peak demand forecasts in Central Coast are approximately 649 MW in 2018 and 679 MW in 2023. Because

this area is along the coast, it has a dominant Winter Peak load profile in certain pockets (such as the Monterey-Carmel sub-area). The winter peak demands in these pockets could be as high as 10 percent more than the summer periods. Accordingly, system assessments in these areas included technical studies using load assumptions for summer and winter peak conditions.

### 2.5.8.2 Area-Specific Assumptions and System Conditions

The study of the Central Coast and Los Padres areas was performed consistent with the general study methodology and assumptions that are described in Section 2.3. The ISO-secured website lists the contingencies that were studied as part of this assessment. Additionally, specific methodology and assumptions that were applicable to the study of the Central Coast and Los Padres areas are provided below.

#### Generation

Generation resources in the Central Coast and Los Padres areas consist of market, qualifying facilities and self-generating units. Table 2.5-18 lists a summary of the generation in the Central Coast and Los Padres area with a detailed generation list provided in Appendix A.

Table 2.5-18: Central Coast and Los Padres area generation summary

<b>Generation</b>	<b>Capacity (MW)</b>
Solar	800
Thermal	3,595
Nuclear	2,400
<b>Total</b>	<b>6,795</b>

#### Load Forecast

Loads within the Central Coast and Los Padres areas reflect a coincident peak load for 1-in-10-year forecast conditions for each peak study scenario. Table 2.5-19 and Table 2.5-20 shows loads modeled for the Central Coast and Los Padres areas assessment.

Table 2.5-19: Load forecasts modeled in the Central Coast and Los Padres area assessment

<b>1-in-10 Year Non-Simultaneous Load Forecast</b>			
<b>PG&amp;E Area</b>	<b>Summer Peak (MW)</b>		
	<b>2015</b>	<b>2018</b>	<b>2023</b>
<b>Central Coast</b>	755	770	803
<b>Los Padres</b>	563	580	605
<b>Total</b>	<b>1,318</b>	<b>1,350</b>	<b>1,408</b>

Table 2.5-20: Load forecasts modeled in the Central Coast and Los Padres area assessment

<b>1-in-10 Year Non-Simultaneous Load Forecast</b>			
<b>PG&amp;E Area</b>	<b>Winter Peak (MW)</b>		
	<b>2015</b>	<b>2018</b>	<b>2023</b>
<b>Central Coast</b>	639	649	679
<b>Los Padres</b>	417	427	445
<b>Total</b>	<b>1,056</b>	<b>1,076</b>	<b>1,124</b>

### **2.5.8.3 Assessment and Recommendations**

The ISO conducted a detailed planning assessment based on the study methodology identified in Section 2.3 to comply with the Reliability Standard requirements of section 2.2. Details of the planning assessment results are presented in Appendix B. The summer and winter peak reliability assessment for the PG&E Central Coast and the summer reliability assessment for the Los Padres area that was performed in 2013 confirmed the previously identified reliability concerns and their associated mitigation plans. The concerns are thermal overloads, low voltages and voltage deviations mostly under Category C contingency conditions. Similar to the previous year's studies, no Category A concerns were identified. The previously approved projects, which include the Midway-Andrew 230 kV, Mesa and Santa Maria SPS in the Los Padres division, Watsonville 115 kV Voltage Conversion, Crazy Horse Substation, Natividad Substation, Moss Landing 230/115 kV Transformer Replacement, etc., in the Central Coast division mitigate a number of thermal overloads and voltage concerns under the identified Category C contingencies. The Watsonville 115 kV Voltage Conversion Project adds a new 115

kV interconnection source to the Santa Cruz area from Crazy Horse. The Midway-Andrew 230 kV Project adds an additional source from Midway 230 kV Substation to the Mesa and Divide 115 kV system via Andrew Substation.

To address the thermal overloads and low voltage concerns identified in this planning cycle, ISO recommends the following transmission development project in the area as a part of the mitigation plan.

#### Estrella Substation Project

The Estrella Substation Project will provide Paso Robles Substation with more reinforced 70 kV sources from Templeton and Estrella. The scope of this project is to construct a new 230/70 kV substation, Estrella Substation, approximately 5 miles east of the existing Paso Robles substation. The Estrella substation will also be located relatively close to the Morro Bay-Gates and Templeton-Gates 230 kV transmission corridor. The Estrella 230 kV bus will be looped into the Morro Bay-Gates 230 kV line. A new 230/70 kV transformer will be installed at the Estrella substation. In addition, a 45 MVA distribution transformer will be installed on the Estrella 230 kV bus. The Estrella 70 kV bus will be looped into the existing San Miguel-Paso Robles 70 kV line. A reverse power relay will be installed on the Estrella 230/70 kV and the existing Templeton 230/70 kV #1 transformer banks to prevent the 70 kV system from feeding the 230 kV system. The Paso Robles-Estrella 70 kV line will be reconducted sufficiently enough to prevent thermal overloads and it will operate at, a minimum, Summer Normal and Summer Emergency ratings of 825 and 975 amps, respectively.

The project will mitigate the thermal overloads and voltage concerns identified in the Los Padres 70 kV system specifically, in the San Miguel, Paso Robles, Templeton, Atascadero, Cayucos and San Luis Obispo areas following Category B contingency due to loss of either the Templeton 230/70 kV #1 Bank or the Paso Robles-Templeton 70 kV Line. These two Category B contingencies put approximately 60-70 MW of load at Paso Robles at risk by activating the existing Paso Robles UVLS during summer peak conditions to alleviate the thermal and low voltage concerns. Also, Category C3 contingency condition involving loss of Morro Bay-Templeton and Templeton-Gates 230 kV lines results in thermal overloads and low voltages in the underlying 70 kV system. With the additional source from the Gates 230 kV system, the Estrella Substation Project will provide robust system reinforcement to the Paso Robles and Templeton 70 kV system operations.

The estimated cost of the project with a single loop into the existing Morro Bay-Gates 230 kV Line is \$35 million to \$45 million. The proposed in-service date of the project is May 2019.

## 2.6 Southern California Bulk Transmission System Assessment

### 2.6.1 Area Description

The southern California bulk transmission system includes the 500 kV and 230 kV transmission system of Southern California Edison (SCE) and San Diego Gas & Electric (SDG&E). ISO members have turned over certain scheduling rights on other transmission, but those facilities are not under ISO operational control and planning responsibilities for those facilities does not rest with the ISO. Figure 2.6–1 provides an illustration of the Southern California's bulk transmission system.

Figure 2.6–1: Map of ISO Southern California Bulk Transmission System

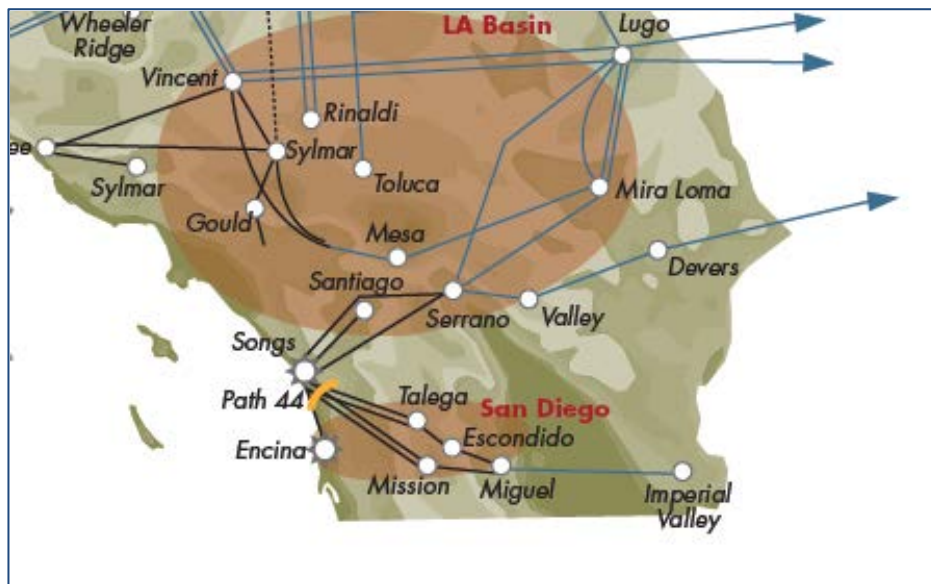

SCE serves over 14 million people in a 50,000 square mile area of central, coastal and southern California, excluding the city of Los Angeles and certain other cities. The bulk transmission system consists of 500 kV and 230 kV transmission facilities. Most of the SCE load is located within the Los Angeles Basin. The CEC's load growth forecast for the entire SCE area is about 378 MW per year.<sup>21</sup> The CEC's 1-in-10 load forecast includes the SCE service area, and the Anaheim Public Utilities, City of Vernon Light & Power Department, Pasadena Water and Power Department, Riverside Public Utilities, California Department of Water Resources and Metropolitan Water District of Southern California loads. The 2018 and 2023 Summer Peak forecast loads are 27,012 MW and 28,690 MW, respectively. SCE area load is served by generation that includes a diverse mix of renewables, qualifying facilities, hydro and gas-fired power plants. Some demand is served by power transfers into southern California on DC and AC transmission lines from the Pacific Northwest and Desert Southwest.

<sup>21</sup> At the onset of the 2013-2014 transmission planning process, the CEC's 2012-2022 demand forecast, posted in August 2012, was utilized because that was the only available forecast at the time. The most recent demand forecast (i.e., 2014 – 2024) was not adopted until December 11, 2013.



SDG&E provides service to 3.4 million consumers through 1.4 million electric meters and more than 840,000 natural gas meters in San Diego and southern Orange counties. Its service area encompasses 4,100 square miles from southern Orange County to the U.S.-Mexico border.

The existing points of imports are the South of San Onofre (SONGS) transmission path (WECC Path 44), the Miguel 500/230 kV substation, the Suncrest 500/230 kV substation, the Otay Mesa-Tijuana 230 kV transmission line and the Imperial Valley Substation.

Historically, the SDG&E import capability is 2,850 MW with all facilities in-service and 2,500 MW with Southwest Power Link (SWPL) out-of-service. When the Sunrise Powerlink (SRPL) project became operational in 2012, the import capability with all lines in service was increased to approximately 3,400 MW.

The 2018 and 2023 Summer Peak forecast loads are 5,652 MW and 6,180 MW, respectively. Most of the SDG&E area load is served by generation that includes a diverse mix of renewables, qualifying facilities, small pumped storage and gas-fired power plants. The remaining demand is served by power transfers into San Diego via points of imports discussed above.

The bulk of the loads in ISO-Controlled Southern California are located in the LA Basin and San Diego local capacity areas. Electric grid reliability in the LA Basin and San Diego is challenged by the retirement of the San Onofre Nuclear Generating Station announced by SCE on June 7, 2013 and the enforcement timeline of OTC regulations for power plants using ocean or estuarine water for cooling. In total, approximately 7,332 MW of generation (5,086 MW gas-fired generation and 2,246 MW San Onofre) in the region are affected. Further, consistent with the CPUC's 2012-2013 LTPP Track 4 scoping memo, the ISO has also taken into account potential retirement of older non-OTC generation in the area. While these changes present significant reliability challenges that must be addressed, they also present a unique opportunity to reduce reliance on conventional resources in favor of "preferred resources" such as energy efficiency and demand response, renewable resources, combined heat and power, and energy storage, in a manner that recognizes their clean, low carbon attributes to meet reliability needs. Due to the interactions between the LA Basin and San Diego needs, the two have been aggregated into a San Diego and LA Basin study area for ISO bulk system analysis in this transmission plan.

Consistent with widely held views of state energy leaders, this transmission plan is based on expectations that an array of solutions will play a role in the significant challenges in the area.

This transmission plan is accordingly based in part on the thinking set out in the "Preliminary Reliability Plan for LA Basin and San Diego", and the decisions made to this point and the study assumptions set out in the CPUC's 2012-2013 LTPP Track 4 scoping memo<sup>22</sup>. The ISO considers those study assumptions to reflect the evolution of the consideration of the array and blend of options for Southern California to maintain electric reliability, minimize carbon in the resource mix and avoid delaying the retirement of OTC units. The state energy leaders agree that only part of the retiring gas-fired generation capacity needs to be replaced and are collaborating to

---

<sup>22</sup> CPUC Long Term Procurement Plan Track 4 Scoping Ruling was filed on May 21, 2013 (<http://docs.cpuc.ca.gov/SearchRes.aspx?DocFormat=ALL&DocID=65202525>)

determine the best options for replacing about 3000 MW of this capacity with plants that use advanced, clean technologies.

As set out below, preferred resources and storage are expected to play an important role in addressing the area's needs. As the term encompasses a range of measures with different characteristics, they have been considered differently. Demand side resources such as energy efficiency programs are accounted for as adjustments to loads, and supply side resources are considered as separate mitigations. While the ISO's analysis focused primarily on the basic assumptions set out below in section 2.6.2, the ISO conducted additional sensitivities on a number of other preferred resource blends extracted from the submissions of SCE into the transmission planning process as discussed further below.

Given these initial inputs and considerations of non-transmission alternatives, including preferred resources, the ISO analysis then focuses on the role transmission solutions may play in meeting part of the overall needs in the area.

## **2.6.2 Area-Specific Assumptions and System Conditions**

The analysis of the San Diego and LA Basin study area was performed consistent with the general study methodology and assumptions described in section 2.3. Some assumptions were updated to be consistent with the assumptions from the CPUC Long Term Procurement Plan Track 4 studies as specified below and as discussed above.

The starting base cases and contingencies that were studied as part of this assessment are available on the ISO-secured website. In addition, specific assumptions and methodology that were applied to the SONGS study area are provided below.

### **Generation**

The bulk transmission system studies use the same set of generation plants that are modeled in the local area studies. A summary of generation is provided in each of the local planning areas within the SCE and SDG&E local areas.

### **Load Forecast**

The San Diego and LA Basin study area's Summer Peak base cases assume the CEC 1-in-10 year load forecast. This is to assess the local reliability impact due to the retirement of SONGS.

Table 2.6-1 provides a summary of the LA Basin and San Diego local capacity areas' coincident 1-in-10 year load forecast in the Summer Peak assessment. The purpose of these assessments is to evaluate the local resource needs, as well as local transmission reinforcement needs to maintain local reliability for the subject study area.

Table 2.6-1: Summer Peak load forecasts modeled in the SONGS study area local reliability assessment

	<b>2018 (MW)</b>	<b>2023 (MW)</b>
SCE's LA Basin Local Capacity Area	21,870	23,258
SDG&E Local Capacity Sub-Area	5,652	6,180
Total San Diego and LA Basin Study Area	27,522	29,438

In addition, incremental energy efficiency (also known as Additional Achievable Energy Efficiency or AAEE) was also assumed and modeled for the studies. The following table 2.6-2 summarizes the AAEE assumed for the local capacity area assessment. These assumptions are consistent with the assumptions from the CPUC Long Term Procurement Plan Track 4 studies.

Table 2.6-2: Summary of AAEE Assumptions

	<b>2018 Forecast/Modeled</b>	<b>2023 Forecast/ Modeled</b>
L.A. Basin	427 / 448 MW	751 / 787 MW
San Diego	99 / 104 MW	187 / 196 MW
Total San Diego and LA Basin study area	526 / 552 MW	938 / 983 MW

The “forecast” amounts in the above table reflect the actual amount of customer energy efficiency reductions forecast by the CEC. The “modeled” amounts reflect an upward adjustment to the values modeled in the ISO studies to account for expected resulting distribution system loss reductions.

### **Existing Protection Systems**

Special Protection Systems (SPS) or remedial action schemes (RAS) that are installed in Southern California area 500 kV and 230kV systems to ensure reliable system performance were included in the studies.

### **Demand Response**

The ISO modeled demand response in the studies based on the CPUC's 2012-2013 LTPP Track 4 Revised Scoping Ruling which recommended a total of 189 MW of existing DR to be used for the San Diego and LA Basin study area under post first contingency, in preparation for the second contingency condition. This amount evolved from the CPUC's decision on 2012-2013 LTPP Track 1 procurement in which the CPUC indicated it was reasonable to assume that some amount of DR resources will be located in the LA Basin, be locally dispatchable and available to meet LCR needs by 2020, and assumed a nominal level of 200 MW. The ISO understood this to entail the repurposing of existing demand programs which may currently lack the current requirements for these needs but which could be adjusted to do so. Demand response that may be procured by the utilities in response to the Track 1 decision or other future decisions were therefore taken to be incremental to this base amount. The ISO further assumed that this repurposed DR would have similar characteristics to those of new DR programs SCE requested the ISO test for determining the effectiveness of DR in meeting local needs. These consist of fast response curtailment (20 minutes) and curtailment durations of 4 hours.

A first contingency, followed by preparatory system adjustment and then a subsequent contingency is sometimes referred to as an overlapping N-1-1 contingency condition, and is considered a Category C (C.3) contingency by NERC reliability standards. The most critical N-1-1 contingency for the San Diego and LA Basin study area is the outage of the Sunrise Powerlink, system readjusted, followed by the outage of the Southwest Powerlink. The ISO modeled the 173 MW of DR for the LA Basin study area based on the most effective locations in the LA Basin (Table 2.6-3), after the occurrence of the first contingency, in preparation for the second contingency. Any location for the 16 MW of DR in San Diego would be effective for this critical N-1-1 contingency. For the locations in the LA Basin, the ISO modeled the amount of DR based on recommendations from the CPUC Energy Division staff. For the locations in San Diego, the ISO selected the substations that serve the largest amount of customer load.

Table 2.6-3: DR Modeled at the Most Effective Locations in the LA Basin and San Diego Areas

Substation	2018 (MW)	2022 (MW)
Alamitos	6.75	Same amount as 2018
Barre	27.0	
Del Amo	25.3	
Ellis	42.4	
Johanna	16.2	
Santiago	28.8	
Viejo	9.9	
Villa Park	24.8	
Bernardo	8.4	
Margarita	8.4	
Total	197.95	

### 2.6.3 Assessment and Recommendations

The ISO conducted a detailed planning assessment based on the study methodology identified in section 2.3 to comply with the Reliability Standard requirements of section 2.2 and from the local capacity reliability study criteria. Details of the planning assessment results are presented in Appendix B.

In landing on its recommendations in this transmission plan, the ISO relied on the resource need assumptions including CPUC-authorized Track 1 procurement (i.e., 1,800 MW for SCE's LA Basin and 308 MW for SDG&E), as well as SCE and SDG&E proposals for Track 4 additional procurement (i.e., 500 MW for SCE and 500 – 550 MW for SDG&E) in the CPUC's 2012-2013 Long Term Procurement Plan process.

The ISO study assessment of the southern area bulk transmission system yielded the following conclusions:

- The most critical contingency that requires the highest amount of resource needs in the San Diego and LA Basin study area is the Category C overlapping outage of the ECO – Miguel 500kV line, system readjusted, followed by the next contingency of Ocotillo – Suncrest 500kV line (i.e., Category C.3, or N-1-1) under post-transient conditions. This

contingency causes post-transient voltage instability that affects the San Diego and LA Basin study area. The WECC post transient voltage stability study methodology and Regional Business Practice (TPL-001-WECC-RBP-2.1) was applied in studying this overlapping contingency.

- Overloading on the Otay Mesa – Tijuana 230kV line (about 7% for the 2023 summer peak case) under an N-1 contingency of the ECO – Miguel 500kV line;
- Low voltage at Miguel 500kV bus under normal conditions for 2018 and 2023 summer peak loads (0.998 per unit, or 499kV, and 0.974 per unit, or 487kV, respectively). This issue is addressed in the San Diego Local Area analysis and recommendations in section 2.8.
- Potential overloading concerns on the Ellis – Johanna and Ellis – Santiago 230kV lines under an overlapping outage (N-1-1) of the Imperial Valley – North Gila 500kV line, followed by either the Ellis – Santiago or Ellis – Johanna 230kV line. This overloading concern was identified for summer 2018 peak load conditions under the scenario that Encina power plant is retired due to compliance with the SWRCB's Policy on OTC plants and SDG&E does not receive authorization from the CPUC to fulfill its request for 500 – 550 MW of local resources from its LTPP Track 4 filing.

The ISO has received proposals comprising a range of potential mitigations in the 2013 request window. The transmission proposals generally fell into one of the following three categories:

- Group I - Transmission upgrades optimizing use of existing transmission lines and not requiring new transmission rights of way
- Group II - Transmission lines strengthening LA/San Diego connection – optimizing use of corridors into the combined area.
- Group III - New transmission into the greater LA Basin/San Diego area.

These groups are described in more detail below.

### ***Group I - Transmission upgrades optimizing use of existing transmission lines***

Figure 2.6-2 sets out the Group I projects which were evaluated. More description is provided below.

Figure 2.6-2: General Locations of Group I Transmission Solutions Transmission upgrades optimizing use of existing transmission lines

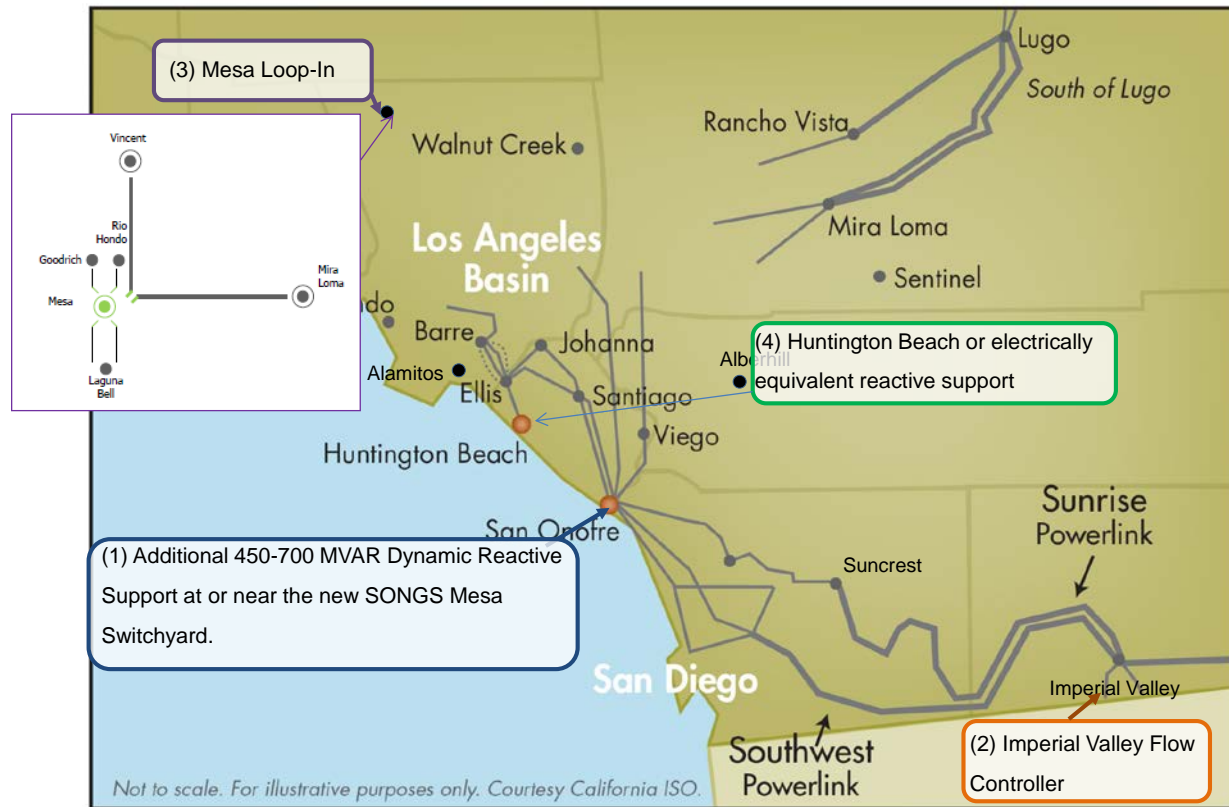

### Additional 450-700 Mvar Dynamic Reactive Support at or near the new SONGS Mesa

In evaluating the effectiveness of the other Group I projects (the Mesa Loop-in and the Imperial Valley Flow Controller) the need for additional reactive power was confirmed. The amounts can vary from 450 to 700 Mvar depending on the type of flow controller used. Further, the ISO considers that 450 Mvar is best suited as synchronous condensers at the San Luis Rey substation, with additional reactive support (if ultimately needed once the selection of the Flow Controller is complete) provided by a new SVC in the vicinity of the SONGS Mesa substation.

### Imperial Valley Flow Controller

The Imperial Valley Flow Controller is 800 MVA, and may be a back-to-back HVDC convertor or phase shifting transformer at or near the Imperial Valley Substation on the 230 kV circuit to CFE's La Rosita substation. Both of these options do allow loop flow through CFE's system under the critical overlapping Category C3 (N-1-1) contingency to provide resources from the Imperial Valley to SDG&E system to help mitigate voltage instability concern under post-transient conditions. The back-to-back HVDC controller provides additional flexibility which may prove necessary, but is estimated to be 3 to 4 times the cost of a phase shifting transformer. The estimated cost of this project is \$55 million–\$300 million. The proposed in-service date is May 1, 2017.

Mesa 500 kV Loop-in Project

The project expands SCE's existing Mesa 230/66/16 kV Substation to include 500 kV service, as illustrated in Figure 2.6.3. This allows SCE to bring a new 500 kV electric service into its metropolitan load center, delivering power from Tehachapi wind resources area or resources located in PG&E service territory or the Northwest via the 500kV bulk transmission network system. Bringing another 500kV source into the heart of the LA Basin by utilizing the existing Vincent – Mira Loma 500kV line also helps reinforce the bulk transmission system and improve its voltage performance against the critical overlapping N-1-1 contingency of the Southwest Powerlink and the Sunrise Powerlink in southern San Diego area. The project includes three 500/230 kV and three 230/66 kV transformer banks providing significant capacity to deliver power from the 500 kV transmission system to load in the LA Metro area. The Vincent-Mira Loma 500 kV, Laguna Bell-Rio Hondo 230 kV & Goodrich-Laguna Bell 230 kV lines will be looped into the expanded substation to provide new source lines and to distribute power toward coastal cities to the south.

Figure 2.6.3: Diagram of the Mesa 500 kV Loop-in Project

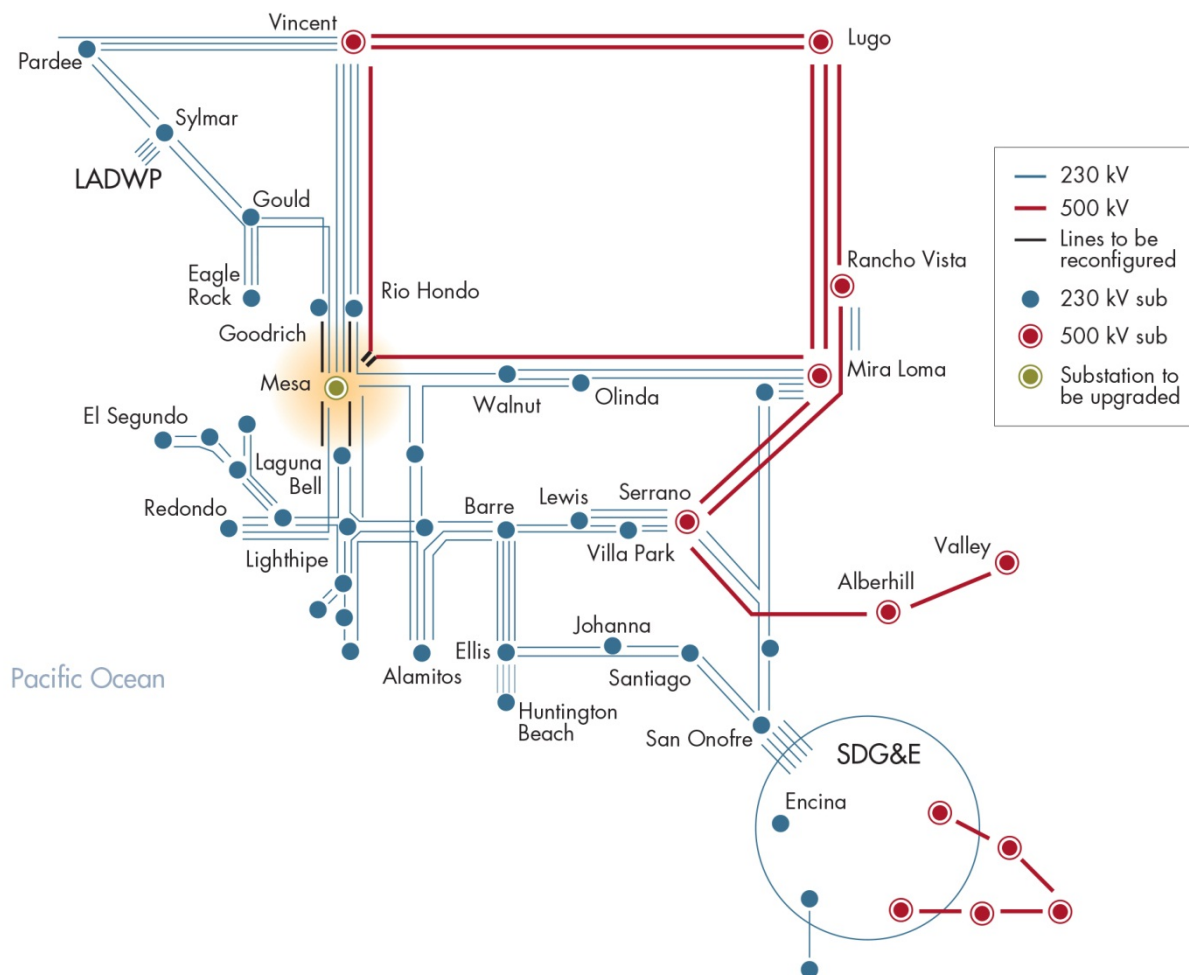



SCE proposed the Mesa 500 kV Loop-in Project along with 500 MW of additional local resource capacity in the Western LA area to:

- address the loading concerns identified in the ISO's reliability assessment results;
- alleviate the increased overall loading on transmission facilities in the LA Metro area resulting from the retirement of SONGS and OTC generation as well as long term load growth in the LA Metro and San Diego areas; and
- reduce the amount of local capacity needed to replace retired generation.

The estimated cost of this project is \$464 million–\$614 million. The proposed in-service date is December 31, 2020.

#### Huntington Beach or electrically equivalent reactive support

The Huntington Beach 3 & 4 generators were converted into two 140 Mvar synchronous condensers prior to the summer of 2013. Up to 540 Mvar of dynamic reactive support will continue to be needed in the vicinity, but can be provided by the existing synchronous condensers and existing generators, by new synchronous condensers if the site is no longer available, or by repowered or new generation in the area.

#### ***Group II - Transmission lines strengthening LA/San Diego connection – optimizing use of corridors into the combined area***

Figure 2.6-4 sets out the Group II projects which were considered. A number of variations of transmission configurations have been proposed and evaluated by the ISO for reinforcing the connections between the San Diego and LA Basin area. These have included both overhead AC and submarine DC cable concepts, and provide a number of alternatives. Siting is expected to be challenging for all these alternatives. The ISO also notes that one Group II alternative, the Enhanced TE-VS option can be further enhanced by adding a 500 MW pumped storage facility which was also submitted to the ISO as a reliability solution to the identified reliability needs. This pumped storage would nominally meet 500 MW of the Total Study Area resource needs but requires the transmission line to be advanced either as a network upgrade or as an interconnection facility.

Figure 2.6-4: Conceptual Transmission Alternatives to Strengthen the Connection of LA Basin and San Diego Local Capacity Areas (Group II)

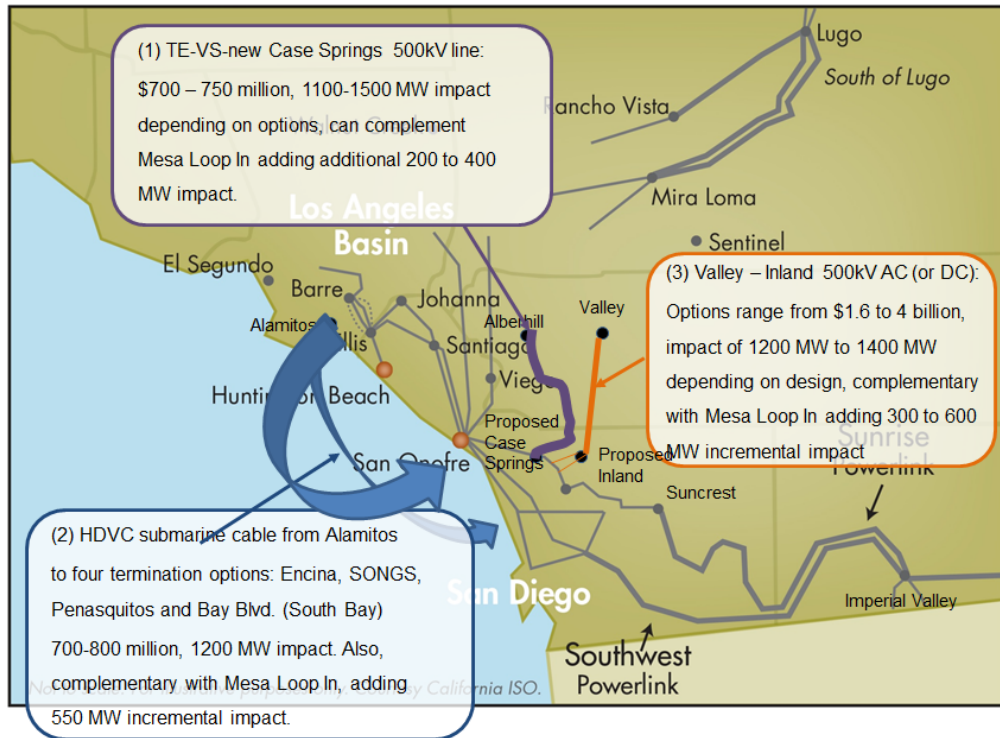

**Group III - New transmission into the greater LA Basin/San Diego area**

Figure 2.6-5 sets out the Group III projects which were considered. A number of variations of transmission configurations have also been proposed for bringing new transmission into the San Diego/LA Basin area from Imperial Valley to access renewables including geothermal development.

Figure 2.6-5: Conceptual Transmission Alternatives into the Greater LA Basin/San Diego Local Capacity Areas (Group III)

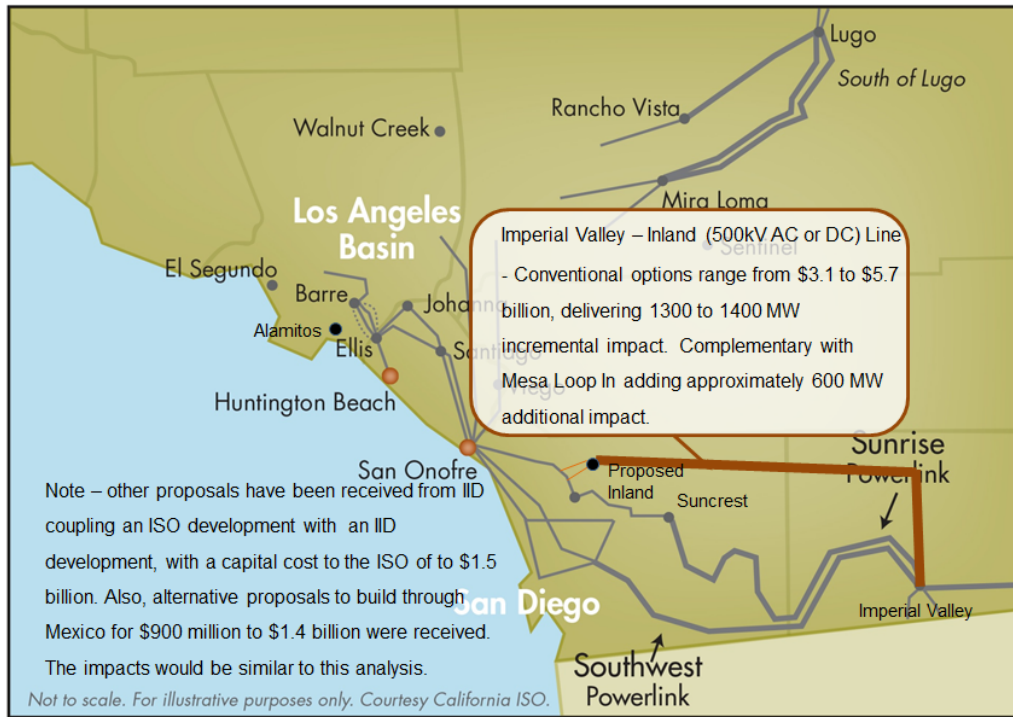

The ISO also analyzed generation alternatives as a standard against which to measure the effectiveness of other solutions, and a range of preferred resource options to understand their potential capabilities. The conventional generation analysis and details of the local preferred resource analysis are provided in Appendix B, and the local preferred resource assessment is summarized below in section 2.6.3.1.

### **2.6.3.1 Local Preferred Resources Assessment (Non-Conventional Transmission Alternative Assessment)**

As set out in chapter 1, the ISO issued a paper<sup>23</sup> on September 4, 2013, in which it presented a methodology to support California's policy emphasis on the use of preferred resources<sup>24</sup> – specifically energy efficiency, demand response, renewable generating resources and energy storage – by considering how such resources can constitute non-conventional solutions to meet local area needs that otherwise would require new transmission or conventional generation infrastructure. In addition to developing a methodology to be applied annually in each transmission planning cycle, the paper also described how the ISO would apply the proposed methodology in future transmission planning cycles.

The general application for this methodology is in grid area situations where a non-conventional alternative such as demand response or some mix of preferred resources could be selected as the preferred solution in the ISO's transmission plan as an alternative to the conventional transmission or generation solution.

In the current planning cycle, the ISO applied a variation of this new approach in the LA Basin and San Diego areas due to the unique circumstances in these areas. Because of the magnitude of the projected reliability needs in these areas incremental transmission options were also studied to complement non-conventional alternatives (i.e., preferred resources), to reduce the need for conventional generation to fill the gap. Thus, unlike the generic application of the methodology in future transmission planning process cycles where preferred resources are considered as an alternative to transmission, the main focus of this effort with respect to the LA Basin and San Diego was to evaluate non-conventional alternatives and identify performance attributes needed from these alternatives that could effectively address the local reliability needs in these two priority areas as part of a basket of resources.

#### SCE-supplied scenarios:

As the ISO's work in this area evolved in determining the necessary attributes, the ISO received several sets of preferred resource development scenario input data from SCE for the LA Basin<sup>25</sup>. These scenarios were meant to test the effectiveness of various combinations of preferred resources that could be acquired by SCE within the authorized and requested procurement in CPUC LTPP Track 1 and Track 4 proceedings, respectively. The ISO supplemented the input from SCE for the LA Basin with scenario assumptions for San Diego and with the system-connected distributed generation information provided by the CPUC as part of the 2013-2014 transmission planning process renewable portfolios (i.e., Commercial Interest

---

<sup>23</sup><http://www.aiso.com/Documents/Paper-Non-ConventionalAlternatives-2013-2014TransmissionPlanningProcess.pdf>

<sup>24</sup> To be precise, "preferred resources" as defined in CPUC proceedings applies more specifically to demand response and energy efficiency, with renewable generation and combined heat and power being next in the loading order. The term is used more generally here consistent with the more general use of the resources sought ahead of conventional generation.

<sup>25</sup> No other stakeholders provided preferred resource scenario input data for consideration by the ISO.

portfolio). Selecting the input data that aligned with the ISO's view of the necessary performance attributes, several scenarios were developed and used as the basis for creating sensitivity power system models starting from the base power system models prepared for the 2013-2014 transmission planning process. These sensitivity power system models were then evaluated to determine the remaining transmission or conventional infrastructure improvements required, for comparison to the identified needs determined from the base power system models.

Preferred resources include environmentally friendly resource alternatives such as energy efficiency, demand response and energy storage. SCE submitted study scenarios that include a combination of gas-fired resources, solar photovoltaic distributed generation, energy storage and demand response. As these scenarios were alternatives for procurement of the authorized Track 1 and requested Track 4 procurement, the total combined resources for these scenarios match the amount authorized by the CPUC for Track 1, plus the amount which SCE seeks for Track 4 LTPP (i.e., 1800 MW + 500 MW = 2300 MW). Table 2.6-4 provides a summary of scenarios which the ISO evaluated – the numbering of the scenarios aligns with the numbering provided by SCE. The gas-fired generation represents an estimated amount of gas-fired generation comprising the ceiling of gas-fired generation authorized for SCE in Track 1, plus 200 MW of the requested Track 4 authorization being obtained from additional gas-fired generation. These amounts are not in addition to the Track 1 and Track 4 amounts.

Table 2.6-4: Summary of Non-Conventional Alternative Assessment

Scenario	Gas Fired Gen (*0)	Solar PV (*1)	Storage (4 hr) (*2)	Storage (2 hr) (*2)	Storage (1 hr) (*2)	Demand Response (x=4 hr) (*3)	Demand Response (x=2 hr) (*3)
Scenario 1	1400	0	0	0	0	900	0
Scenario 3	1400	320	580	0	0	0	0
Scenario 4	1400	320	290	290	0	0	0

The study results are summarized in Appendix B. The following are key findings:

- None of the options considered would be able to mitigate on their own without transmission upgrades for the most critical Category C (N-1-1) contingency;
- Coupled with the transmission upgrades presented in Section 2.6.3, especially with the option of the back-to-back DC flow controller at Imperial Valley Substation, scenarios 1 and 3 appear to be feasible in mitigating the most critical contingency discussed above. The transmission option of the phase shifting transformer appears to be feasible for Scenario 3 above, mainly due to lower level of loads considered for the analyses.
- Scenario 4 appears to be infeasible due to higher net peak load resulting for the San Diego and LA Basin study area and some conventional resources partly located in less optimal area of the northwest LA Basin.

- Most effective locations for mitigating post transient voltage instability due to the critical contingency were determined to be in the San Diego local capacity area and the southwest LA Basin sub-area. The resources in the southwest LA Basin are approximately 50% as effective as resources located in San Diego due to the southwest LA Basin's close proximity to San Diego local capacity area. The resources located in the northwest LA Basin were determined not to be effective for mitigating the post transient voltage instability concern due to the critical N-1-1 contingency.

#### Pumped Storage:

In addition to the preferred resource scenarios submitted by SCE, the ISO also received one proposal for a pumped storage facility (the Lake Elsinore Advanced Pumped Storage project discussed earlier in association with the TE-VS transmission submission) which was also submitted as a generation alternative. This pumped storage would require the transmission line to be advanced either as a network upgrade (which was discussed above) or as an interconnection facility. The ISO assessed the pumped storage facility to verify that if the storage facility proceeded as a market-based resource and the transmission proceeded as a generator interconnection facility the pumped storage facility would nominally meet 500 MW of the total local resource needs.

### **2.6.3.2 Recommendations**

The ISO is recommending specific transmission development in this planning cycle. The recommendations form part of a larger recommended strategy for further analysis and input into future processes, including future transmission planning cycles.

#### Overarching strategy:

This strategy consists of three tracks:

- Recommend approval of "optimizing existing transmission" projects to address a portion of the residual needs and as a more certain hedge against other resources failing to develop on schedule. (Group I – set out below) These mitigations provide material reductions in local capacity requirements, without the addition of new transmission rights of way. This provides the best use of existing transmission lines and transmission rights of way, as well as minimizing risk about permitting and the timing of permitting.
- Initiate longer term analysis (10 to 20 year) in 2014-2015 or 2015-2016 cycle to assess the need for potential LA/San Diego connector projects (Group II) in light of evolving load forecasts and the potential for preferred resources and storage.
- Feed analysis of potential "policy" transmission lines (Group III) into the LA Basin/San Diego area into state policy discussions, recognizing that those may obviate the need to advance a future Group II project.

The strategy is based on the principles of least regrets transmission development, focusing on maintaining reliability, supporting preferred resources and minimizing or delaying new transmission lines by focusing first on the Group I solutions that do not require new transmission lines. It provides the maximum opportunity for preferred resources to develop in lieu of new

transmission lines (Group II or Group III transmission proposals) which represent higher cost, new transmission right of way, possibly lengthier development timelines, and higher regulatory uncertainty than the Group I projects. The recommended strategy also provides the least risk of the need for delay in compliance with OTC generation requirements. Further, the ISO's analysis demonstrates that the recommended resources perform complementary to many of the Group II and Group III proposals should those be developed to address needs beyond this transmission plan's scope.

In setting out the second track of this strategy, the ISO recognizes the value that further reinforcement of the transmission corridors between the LA Basin and San Diego may provide in meeting the remaining residual need, or future needs beyond the current planning horizon. Additional analysis and process will be required to determine which of these in fact may prove to be the superior next addition, as environmental considerations and the future of storage projects such as LEAPS evolve. However, it is not necessary or reasonable to seek approval of these more expensive alternatives, especially on timelines that are extremely aggressive and potentially unlikely to be met given the need for reliability and the higher than usual degree of uncertainty with many of the inputs into this analysis.

The third track of this strategy focuses on ensuring state policy discussions are informed about the potential benefits of the Group III projects in meeting the LA Basin and San Diego area needs. The benefits of the projects bringing additional resources into the LA Basin and San Diego study area were also assessed. These projects provide in general an increased level of overall benefit, but generally at a significantly increased cost and increased challenges in siting and permitting over Group II projects. A major benefit of these projects in general was other potential policy benefits they could bring in accessing renewable generation sources. The need for those additional resources is not supported by clear federal or state policy direction at this time such that more expensive alternatives can be pursued as policy-driven enhancements. The ISO expects such support could enable this type of project to supplant the overall less costly LA Basin/San Diego connector projects, which provide reliability value but without the level of policy benefits of the Group III projects.

#### Specific Recommendations:

The specific immediate solutions the ISO recommends for approval in this transmission plan are set out below. The recommended transmission solutions help reduce local resource needs by about 800 MW to 1680 MW for 2023 summer peak load conditions. These solutions optimize the use of the existing transmission lines in the San Diego and LA Basin study area by reducing local capacity needs without requiring new transmission lines:

1. For the post transient voltage instability and the contingency overloading concerns on the Otay Mesa – Tijuana 230kV line, the following are proposed solutions:
  - a. The ISO recommends the installation of a flow controller (i.e., back-to-back DC or phase shifting transformer) at Imperial Valley Substation. Back-to-back DC flow controller is a more robust option that is effective under various studied load and resource scenarios. The cost, however, is about three to four times more

expensive than the phase shifting transformer as it includes a small switchyard installation, as well as DC components that offer precise flow control between SDG&E and CFE. Both of these options do allow loop flow through CFE's system under the critical overlapping Category C3 (N-1-1) contingency to provide resources from the Imperial Valley to SDG&E system to help mitigate voltage instability concern under post-transient conditions. With the phase shifter, the loop flow through CFE system results from the "natural" flow due to blocked phase angle on the phase shifter for the N-1-1 contingency. Nevertheless this loop flow, under contingency condition, is critical in "wheeling" resources from Imperial Valley to SDG&E system to mitigate post transient voltage instability. The back-to-back DC flow controller can be programmed to control this loop flow, under an overlapping N-1-1 contingency, with precision and with high speed (in the range of milliseconds).

Additional coordination with CFE will be necessary before a final determination can be made if the less costly phase shifting transformer will suffice, or if the more expensive back-to-back HVDC converter technology is required. It will be necessary to pursue both solutions recognizing that only one solution will ultimately be selected. The ISO has concluded that the installation of a phase shifting transformer constitutes an upgrade to an existing substation facility due to the nature of the equipment and would therefore not be eligible for the competitive procurement process. The ISO has noted that due to the large number of facilities eligible for competitive solicitation process identified in this plan, that it will be necessary to stage or stagger the receipt and processing of all applications into the competitive solicitation process. The ISO will stage the receipt and consideration of the back-to-back HVDC converter technology (if selected as the preferred technology) towards the end of the staging process.

- b. The ISO has identified the need of additional 450 - 700 MVAR of dynamic reactive support at future SONGS Mesa Substation or electrically equivalent location in the vicinity. To address this need:
  - i. The ISO recommends installing two synchronous condensers at the San Luis Rey substation totaling 450 MVAR. In addition to the long term benefits, this location and capability provides the further benefit of providing coverage for the possible delay of the SONGS Mesa SVC approved in the 2012-2013 transmission plan and can obviate the potential interim need for converting a SONGS generator into a synchronous condenser.
  - ii. The potential need for 250 MVAR of additional dynamic reactive support at SONGS Mesa or an electrically equivalent location will be reviewed in future planning cycles. This will allow the ISO to factor in the CPUC's potential decisions on LTPP Track 4, as well as final selection of the flow controller at the Imperial Valley Substation.



- c. The ISO recommends proceeding with the Mesa loop-in project in the LA Basin. With this project, a new 500/230/66kV substation will be rebuilt on the property of the existing Mesa 230/66kV substation. With the addition of 500kV voltage, a new source from bulk transmission will be established in the LA Basin to bring power from Tehachapi renewables or power transfer from PG&E via WECC Path 26.
  - d. The ISO has identified the potential need for further installation of additional dynamic reactive support up to about 540 MVAR in the southern Orange County if Huntington Beach power plant is retired and not repowered. This will be reviewed in future planning cycles.
2. The ISO proposes to revisit in the 2014-2015 transmission planning cycle the need for the Ellis Corridor Upgrade. To mitigate potential overloading concerns on the Ellis – Johanna or Ellis – Santiago 230kV line under a Category C.3 outage (i.e., overlapping N-1-1 contingency), either (a) SDG&E is allowed to fulfill its LTPP Track 1 authorization for local resources (308 MW) and its request for Track 4 (i.e., 500 – 550 MW), or (b) SCE is allowed to fulfill some of its Track 4 request for local resources at either Johanna or Santiago substation; or (c) if either Option 3(a) or (b) does not materialize, then the Ellis Corridor Upgrade transmission project would be needed. Based on SCE's proposed Ellis Corridor Upgrade submittal to the ISO Request Window, it appears that it would take approximately two years from the approval date to implement this potential project. This can be implemented rather quickly because the upgrades would involve line terminating equipment located at the substation and line clearance mitigation. Due to short lead time required for this transmission upgrade, and the status of the SDG&E and SCE requests for local resources related to LTPP Track 4, the ISO recommends that this issue is to be revisited in the 2014/2015 transmission planning process after the CPUC decisions for Track 4 are issued.

Table 2.6-5 provides a summary of proposed transmission solutions, high level estimated costs and estimated local resource reduction benefits due to each transmission solution.

Table 2.6-5: Summary of Proposed Transmission Solutions, Cost Estimates and Local Resource Reduction Benefits

No.	Transmission Upgrade Option	Proposed In-Service Date	Estimated Cost (\$ Million)	Local Resources Reduction Benefits (MW)
1	Additional 450 MVAR of dynamic reactive support at San Luis Rey (i.e., two 225 MVAR synchronous condensers)	June 2018 for permanent installation at SONGS Mesa or near vicinity (San Luis Rey)	~\$80 M	-100 to -200 (benefits in 2018; when coupled with other projects (i.e., items 2 and 3 below, it will be part of the benefits of those projects)
2	Imperial Valley Flow Controller (IV B2BDC or Phase Shifter) – for emergency flow control to prevent overloading on CFE line and voltage collapse under Category C.3 contingency	May 2017	\$55 - \$300 M	-400 to -840
3	Mesa Loop-In Project	December 2020	\$464 - \$614 M	-300 to -640
<b>TOTAL</b>			\$599 - \$994 M	-800 to -1680

These recommendations do not address all of the requirement identified for the San Diego and LA Basin area; they result in a residual need of up to 900 MW overall for those areas, assuming conservative estimates for their overall effectiveness and based on the resource assumptions discussed earlier. The residual need leaves room in future planning and procurement cycles to take into account changes in load forecasting as well as anticipated increases in forecasts for preferred resources – energy efficiency in particular. Further analysis in the 2014-2015 transmission planning cycle will be necessary to assess residual need in light of new load forecast information and further clarity on the specifics of conventional and preferred resources and storage.

By applying “least regrets” transmission mitigations in this plan, the residual need becomes a more manageable amount for procurement measures to address, and ensures ample opportunity for further development of preferred resources.

## 2.7 SCE Local Areas Assessment

### 2.7.1 Tehachapi and Big Creek Corridor

#### 2.7.1.1 Area Description

The Tehachapi and Big Creek Corridor area consists of the SCE transmission system north of Vincent. The area includes the following:



- WECC Path 26 — three 500 kV transmission lines between PG&E's Midway substation and SCE's Vincent substation with Whirlwind 500 kV loop-in to the third line;
- Tehachapi area — Windhub – Whirlwind 500 kV, Windhub – Antelope 500 kV, and two Antelope – Vincent 500 kV lines;
- 230 kV transmission system between Vincent and Big Creek Hydroelectric project that serves customers in Tulare county; and
- Antelope-Bailey 66 kV system which serves the Antelope Valley, Gorman, and Tehachapi Pass areas.

There are three major transmission projects that have been approved in prior cycles by the ISO in this area, which are as follows:

- San Joaquin Cross Valley Loop Transmission Project (in-service date: 2014);
- Tehachapi Renewable Transmission Project (in-service date: 2016); and
- East Kern Wind Resource Area 66 kV Reconfiguration Project (complete).<sup>26</sup>

#### 2.7.1.2 Area-Specific Assumptions and System Conditions

The Tehachapi and Big Creek area study was performed consistent with the general study methodology and assumptions described section 2.3.

The ISO-secured participant portal lists the base cases and contingencies that were studied as part of this assessment. Additionally, specific methodology and assumptions that were applicable to the study area are provided below.

<sup>26</sup> The transmission portion of the East Kern Wind Resource Area is complete. The distribution reconfiguration portion of the project is still in progress, and is planned to be completed by June 30, 2014.

## Generation

Table 2.7-1 lists a summary of the generation in the Tehachapi and Big Creek area, with detailed generation listed in Appendix A.

Table 2.7-1: Tehachapi and Big Creek area generation summary

<b>Generation</b>	<b>Capacity (MW)</b>
Thermal	1,720.1
Hydro	1,201.3
Wind	2,386.1
Solar	130.0
<b>Total</b>	<b>5,437.5</b>

## Load Forecast

The ISO Summer Peak base case assumes the CEC's 1-in-10 year load forecast and includes system losses. Table 2.7-2 shows the Tehachapi and Big Creek area load in the Summer Peak assessment cases excluding losses.

The ISO Summer Light Load and Spring Off-Peak base cases assume 50 percent and 65 percent of the 1-in-2 year load forecast, respectively.

Table 2.7-2: Summer Peak load forecasts modeled in the SCE's Tehachapi and Big Creek area assessment

<b>Tehachapi and Big Creek Area Coincident A-Bank Load Forecast (MW)</b>			
<b>Substation Load and Large Customer Load (1-in-10 Year)</b>			
<b>Substation</b>	<b>2015</b>	<b>2018</b>	<b>2023</b>
Antelope-Bailey 220/66 kV	754	775	800
Rector 220/66 kV	835	859	904
Springville 220/66 kV	231	245	255
Vestal 220/66 kV	207	210	216
Big Creek 220/33 kV	9	9	9

**2.7.1.3 Assessment and Recommendations**

The ISO conducted detailed planning assessment based on the study methodology identified in section 2.3 to comply with the Reliability Standard requirements of section 2.2. Details of the planning assessment results are presented in Appendix B. The reliability assessment did not indicate any system performance concerns.

## 2.7.2 Antelope-Bailey

### 2.7.2.1 Area Description



The Antelope-Bailey area is composed of the ISO Controlled 66 kV transmission facilities connected between Antelope and Bailey substations.

One major transmission project, the East Kern Wind Resource Area (EKWRA) 66 kV Reconfiguration Project is complete as shown above, and was modeled in the base cases.

Once the transmission project is in-service, the area will consist of the Antelope-Bailey and Windhub 66 kV systems.

### 2.7.2.2 Area-Specific Assumptions and System Conditions

The Antelope-Bailey area study was performed consistent with the general study methodology and assumptions described in section 2.3.

The ISO-secured participant portal lists the base cases and contingencies that were studied as part of this assessment. Additionally, specific methodology and assumptions that were applicable to the study area are provided below.

#### Generation

Table 2.7-3 lists a summary of the generation in the Antelope-Bailey area, with detailed generation listed in Appendix A.

Table 2.7-3: Antelope-Bailey area generation summary

Generation	Capacity (MW)
Hydro	34.0
Wind	355.1
Thermal	66.0
Solar	20.0
<b>Total</b>	<b>475.1</b>

### Load Forecast

The ISO Summer Peak base case assumes the CEC's 1-in-10 year load forecast. This forecast load includes system losses. Table 2.7-4 shows the Antelope-Bailey area load in the Summer Peak assessment cases excluding losses.

The ISO Summer Light Load and Spring Off-Peak base cases assume 50 percent and 60 percent of the 1-in-2 year load forecast, respectively.

Table 2.7-4: Summer Peak load forecasts modeled in the SCE's Antelope-Bailey area assessment

<b>Antelope-Bailey Area Coincident A-Bank Load Forecast (MW)</b>			
<b>Substation Load and Large Customer Load (1-in-10 Year)</b>			
<b>Area</b>	<b>2015</b>	<b>2018</b>	<b>2023</b>
Antelope-Bailey 220/66 kV	754	775	800

#### 2.7.2.3 Assessment and Recommendations

The ISO conducted detailed planning assessment based on the study methodology identified in section 2.3 to comply with the Reliability Standard requirements of section 2.2. Details of the planning assessment results are presented in appendix B. The reliability assessment did not indicate any system performance concerns.

## 2.7.3 North of Lugo Area

### 2.7.3.1 Area Description

The North of Lugo transmission system serves San Bernardino, Kern, Inyo and Mono counties. The figure below depicts the geographic location of the North of Lugo area. The area extends more than 270 miles.



The North of Lugo electric transmission system comprises 55 kV, 115 kV and 230 kV transmission facilities. In the north, it has inter-ties with LADWP and Sierra Pacific Power. In the south, it connects to the Eldorado substation through the Ivanpah-Baker-Cool Water–Dunn Siding-Mountain Pass 115 kV line. It also connects to the Pisgah substation through the Lugo-Pisgah #1 and #2 230 kV lines. Two 500/230 kV transformer banks at the Lugo substation provide access to SCE's main system. The North of Lugo area can be divided into the following sub-areas: North of Control; South of Control to Inyokern; South of Inyokern to Kramer; South of Kramer; and Victor.

### 2.7.3.2 Area-Specific Assumptions and System Conditions

The North of Lugo area study was performed consistent with the general study methodology and assumptions described in section 2.3. As described in section 2.3, some potentially planned renewable generation projects were modeled.

The ISO-secured website lists the base cases and contingencies that were studied as part of this assessment. Additionally, specific methodology and assumptions that were applicable to the study area are provided below.

#### Generation

Table 2.7-5 lists a summary of the generation in the North of Lugo area, with detailed generation listed in Appendix A.



Table 2.7-5: North of Lugo area generation summary

<b>Generation</b>	<b>Capacity (MW)</b>
Thermal	1,756.4
Hydro	51
Solar	613.8
Geothermal	276.5
<b>Total</b>	<b>2,698</b>

### Load Forecast

The ISO Summer Peak base case assumes the CEC's 1-in-10 year load forecast. This forecast load includes system losses. Table 2.7-6 shows the North of Lugo area load in the Summer Peak assessment cases excluding losses.

The ISO Summer Light-Load base case assumes 25-30 percent of the 1-in-10 year load forecast. The Off-Peak base case assumes approximately 60 percent of the 1-in-10 year load forecast.

Table 2.7-6: Load forecasts modeled in the North of Lugo area

<b>North of Lugo Area Coincident A-Bank Load Forecast (MW) Substation Load and Large Customer Load (1-in-10 Year)</b>			
<b>Substation</b>	<b>2015</b>	<b>2018</b>	<b>2023</b>
Kramer / Inyokern / Coolwater 220/115	370	390	410
Victor 220/115	842	883	967
Control 115kV	57	61	69

### 2.7.3.3 Assessment and Recommendations

The ISO conducted a detailed planning assessment based on the study methodology identified in section 2.3 to comply with the Reliability Standard requirements of section 2.2. Details of the planning assessment results are presented in Appendix B. The Summer Peak reliability assessment of the North of Lugo area revealed several reliability concerns. These concerns consist of high and low voltages, voltage deviations and thermal overloads under Category B and C contingencies. Based on the assessment results, the ISO recommends using transformer tap adjustment, generation re-dispatch (for Category B and common-mode Category C issues)

and system readjustments (curtail generation, reactive device switching) for the N-1-1 issues, to address the identified reliability concerns in the North of Lugo area.

For the N-2 contingency of Victor-Lugo 230 kV lines #1 and #2, a transient voltage dip (below 0.7 pu) was observed in Victor 115 kV area. The voltage failed to recover above an acceptable level. An interim SPS will open the two 115 kV lines between Kramer - Victor and Roadway – Victor if the voltage fails to recover for 2 seconds. This will drop the entire Victor 115 kV load (up to 842 MW for a common-mode N-2 contingency in 2015). To avoid this potential loss of load for a common-mode N-2 contingency, the ISO recommends to loop in the two 230 kV lines between Lugo and Kramer into the Victor 230 kV substation, which was a potential mitigation submitted by SCE.

## 2.7.4 East of Lugo

### 2.7.4.1 Area Description

The East of Lugo area consists of the transmission system between the Lugo and Eldorado substations. The East of Lugo area is a major transmission corridor connecting California with Nevada and Arizona; a part of Path 46 (West of River), and is heavily integrated with LADWP and other neighboring transmission systems. The SDG&E owned Merchant 230 kV switchyard became part of the ISO controlled grid and now radially connects to the jointly owned Eldorado 230 kV substation. Merchant substation was formerly in the NV Energy balancing authority, but after a system reconfiguration in 2012, it became part of the ISO system. The East of Lugo bulk system consists of the following:



- 500 kV transmission lines from Lugo to Eldorado and Mohave;
- 230 kV transmission lines from Lugo to Pisgah to Eldorado;
- 115 kV transmission line from Cool Water to Ivanpah; and
- 500 kV and 230 kV tie lines with neighboring systems.

### 2.7.4.2 Study Assumptions and System Conditions

The East of Lugo area study was performed consistent with the general study methodology and assumptions described in section 2.3. The ISO-secured website lists the base cases and contingencies that were studied as part of this assessment. As described in section 2.3.2.5, some potentially planned renewable generation projects were modeled. In addition, specific assumptions and methodology that applied to the East of Lugo area study are provided below.

#### Transmission

The CPUC and ISO approved the Eldorado-Ivanpah Transmission Project, a new 220/115 kV Ivanpah substation and an upgrade of a 35-mile portion of an existing transmission line connecting the new substation to Eldorado Substation, was energized in Q4 of 2013.

Transmission upgrades consisting of the Lugo - Eldorado 500 kV series capacitor and terminal equipment upgrade, re-route Eldorado - Lugo 500 kV line, which were approved as policy-driven upgrades in 2012-2013 ISO Transmission Plan, are modeled in the 2018 and 2023 study cases.

In light of the FERC approved Transition Agreement between ISO and Valley Electric Association, the planned interconnection tie between VEA's newly proposed 230 kV Bob Switchyard and SCE's new 220 kV Eldorado substation is assumed to be in-service during the year 2015.

## Generation

There are about 577 MW of existing generation connected to the SDG&E owned Merchant substation and about 400 MW of renewable generation in the Ivanpah area (under construction, and to be in-service by the year 2013-2014). Table 2.7-7 lists the generation in the East of Lugo area with detailed generation listed in Appendix A.

Table 2.7-7: Generation in the East of Lugo area

Generation	Capacity (MW)
Thermal	519
Solar	450
<b>Total</b>	<b>969</b>

## Load Forecast

The ISO Summer Peak base case assumes the CEC's 1-in-10 year load forecast. This forecast load includes system losses but excludes power plant auxiliary loads in the area. The SCE Summer Light Load base cases assume 50 percent of the 1-in-2 year load forecast.

Table 2.7-8 provides a summary of the Eldorado area load in the Summer Peak assessment.

Table 2.7-8: Summer Peak load forecasts modeled in the East of Lugo area assessment

Substation	2015	2018	2023
Eldorado Area (MW)	3	3	3

### 2.7.4.3 Assessment and Recommendations

The ISO conducted detailed planning assessment based on the study methodology identified in section 2.3 to comply with the Reliability Standard requirements of section 2.2. Details of the planning assessment results are presented in Appendix B. The 2013-2023 reliability assessment of the SCE East of Lugo area resulted in the following reliability concern:

- In study year 2015, a thermal overload was observed on LADWP's Lugo – Victorville 500kV line for the N-1-1 contingency of Palo Verde – Colorado River 500kV line followed by Hassayampa – Hoodoo Wash (or Hoodoo Wash – North Gila) 500 kV line. The recommended mitigation for this reliability concern is to curtail generation in the East of Pisgah area or curtail the West of River (WOR) flows after the first contingency.
- This reliability concern was not observed in the later study years because of modeling the policy-driven project to upgrade Lugo – Eldorado 500 kV series capacitor and terminal equipment.

## 2.7.5 Eastern Area

### 2.7.5.1 Area Description

The ISO controlled grid in the Eastern Area serves the portion of Riverside County around and to the west of the Devers Substation. The figure below depicts the geographic location of the area. The system is composed of 500 kV, 230 kV and 161 kV transmission facilities from Devers Substation to Palo Verde Substation in Arizona. The area has ties to SRP, IID, MWD, and WALC facilities.



The ISO approved the following major transmission projects in this area in prior planning cycles:

- Valley-Devers-Colorado River 500 kV Transmission Project (in-service date: 2013);
- Coachella-Devers 230 kV Loop-in Project (in-service);
- Path 42 Upgrade Project (2014); and
- Devers-Mirage 115 kV Split Project (in-service).

The ISO relinquished control of the Devers-Mirage 115 kV facilities after the split.

### 2.7.5.2 Area-Specific Assumptions and System Conditions

The Eastern Area reliability assessment was performed consistent with the general study methodology and assumptions described in section 2.3. The ISO's secure participant portal lists the base cases and contingencies that were studied.

Additionally, specific assumptions and methodology that were applied to the Eastern Area study are provided below.

#### Generation

Table 2.7-9 lists a summary of generation in the Eastern area. A detailed list of generation in the area is provided in Appendix A.

Table 2.7-9: Eastern area generation summary

<b>Generation</b>	<b>Capacity (MW)</b>
Thermal	1,506
Wind	772
Solar	800*
<b>Total</b>	<b>3,078</b>

\* The capacity value shown includes generation currently under construction.

### Load Forecast

The ISO Summer Peak base cases are based on the CEC 1-in-10 load forecast. The forecast load includes system losses. Table 2.7-10 provides a summary of the Eastern Area coincident substation load used in the Summer Peak assessment.

The Summer Light Load and Spring Off-Peak base cases assume 50 percent and 65 percent of the 1-in-2 peak load forecast, respectively.

Table 2.7-10: Summer Peak load forecasts modeled in the Eastern Area assessment

<b>Eastern Area Coincident Load Forecast (MW)</b>			
<b>Substation Load (1-in-10 Year)</b>			
<b>Substation</b>	<b>2015</b>	<b>2018</b>	<b>2023</b>
Blythe	74	78	85
Camino	2	2	2
Devers	480	494	518
Eagle Mountain	2	2	2
Mirage	443	461	491
<b>Total</b>	<b>1000</b>	<b>1037</b>	<b>1098</b>

### **2.7.5.3 Assessment and Recommendations**

The ISO conducted a detailed planning assessment based on the study methodology identified in section 2.3 to comply with the Reliability Standard requirements of section 2.2. Details of the planning assessment results are presented in Appendix B.

The 2013-2022 reliability assessment for the SCE Eastern Area identified the following reliability concerns that require mitigation.

- Single and overlapping outages involving the Julian Hinds–Mirage 230 kV line were found to cause the Blythe Energy RAS to trip the Blythe generation tie line at Julian Hinds which was found to have adverse impacts on voltages in the area. The ISO recommends increasing the rating of the MWD Julian Hinds bus section and the corresponding set-point of the Blythe Energy RAS to prevent the RAS from tripping the tie line (complete).
- Overlapping outages of Julian Hinds–Mirage and Iron Mountain–Camino or Julian Hinds–Mirage and Eagle Mountain–Iron Mountain were found to cause thermal overload on Eagle Mountain–Blythe 161 kV line and voltage instability in the area. The ISO recommends developing operating procedures to open the Eagle Mountain–Blythe 161 kV line after the first outage (target date: February 2014).
- Single and overlapping outages involving the MWD Gene–Parker 230 kV line were found to cause voltage and/or frequency deviation concerns. SCE is coordinating with MWD and Western Area Power Administration (WAPA) to place the second MWD Camino–Mead 230 kV line back into service in order to address these concerns (target date: December 2014).

## 2.7.6 Los Angeles Metro Area

### 2.7.6.1 Area Description

The Los Angeles Metro area consists of the SCE-owned 500 kV and 230 kV facilities that serve major metropolitan areas in the Orange, Riverside, San Bernardino, Los Angeles, Ventura and Santa Barbara counties. The boundary of LA Metro area is marked by the Vincent, Lugo and Devers 500 kV substations. The bulk of SCE load as well as most Southern California coastal generation is located in the LA Metro area.



The ISO has approved the following major transmission projects in this area in prior planning cycles:

- reconfigure Barre–Ellis No 1 & 2 230 kV lines into four lines (in-service);
- four 80 MVar capacitors at Johanna (1), Santiago (1) and Viejo (2) (in-service);
- Method of Service for Alberhill 500/115 kV Substation (in-service date 2017); and
- Method of Service for Wildlife 230/66 kV Substation (in-service date 2015).

As noted in section 2.6, Southern California Bulk Transmission System Assessment, the San Onofre Nuclear Generating Station (SONGS), which had an installed capacity of 2,246 MW, was retired on June 7, 2013. A total of about 6,100 MW of generation in the Metro Area is also expected to retire by the end of 2020 because of compliance with the State Water Resources Control Board (SWRCB) once-through cooling (OTC) regulations. The retirement of these generating facilities will stress the existing transmission system and impact its ability to provide reliable service to electricity customers in the LA Metro and San Diego areas.

In its LTPP Track 1 decision, the CPUC has authorized SCE to procure up to 1,800 MW of local capacity in the Western LA Basin area and up to 290 MW in the Moor Park area to replace retiring OTC generation. The CPUC is also expected to determine the additional local capacity needs arising from the subsequent retirement of SONGS at the conclusion of the ongoing LTPP Track 4 Proceeding. The specific location and timing of the authorized local capacity additions will not be known until SCE has completed its procurement process.

The overall bulk system needs for the LA Basin and San Diego are discussed in section 2.6 above. This section addresses local system issues in the LA Basin area with and without the recommended solutions set out in section 2.6 to ascertain the impact of those solutions on the local system and determine any additional mitigations required for local system concerns.

### 2.7.6.2 Area-Specific Assumptions and System Conditions

The Metro area study was performed consistent with the general study methodology and assumptions described in section 2.3. The ISO's secure participant portal lists the base cases and contingencies that were studied as part of this assessment. In addition, specific assumptions and methodology that were applied to the Metro area study are provided below.



## Generation

Table 2.7-11 lists a summary of the existing generation in the Metro area, with detailed generation listed in appendix A.

Table 2.7-11: LA Metro area existing generation summary

<b>Generation</b>	<b>Capacity (MW)</b>
Thermal	11,701
Hydro	319
Nuclear	0
Biomass	120
<b>Total</b>	<b>12,140</b>

SONGS was removed from all base cases and OTC generators were assumed to retire per their respective compliance dates. In the 2023 Summer Peak case, OTC replacement capacity consistent with the amounts authorized in the CPUC LTTP Track 1 decision was modeled.

## Load Forecast

The Summer Peak base cases assume the CEC 1-in-10 year load forecast. This forecast load includes system losses. Table 2.7-2 provides a summary of the Metro area substation load used in the Summer Peak assessment.

The Summer Light Load and Spring Off-Peak base cases assume 50 percent and 65 percent of the coincident 1-in-2 year load forecast, respectively.

Table 2.7-12: Summer Peak load forecasts modeled in the LA Metro area assessment

<b>LA Metro Area Coincident A-Bank Load Forecast (MW) Substation Load (1-in-10 Year)</b>			
<b>Substation</b>	<b>2015</b>	<b>2018</b>	<b>2023</b>
Alamitos 220/66 (S)	189	194	208
Alberhill 500/115 (S)	0	357	395
Barre C 220/66 (S)	727	735	753
Center B 220/66 (S)	477	483	491
Chevmain 220/66 (S)	167	168	169
Chino S 220/66 (S)	751	777	824
Del Amo C 220/66 (S)	561	586	621
Eagle Rock 220/66 (S)	261	289	318
El Casco 220/115 (S)	198	206	223
El Nido 220/66 (S)	408	418	434
Ellis C 220/66 (S)	656	675	703
Etiwanda Ameron (S)	18	18	18
Etiwanda W 220/66 (S)	698	757	805
Goleta 220/66 (S)	317	327	342
Goodrich 220/33 (S)	336	345	363
Gould 220/66 (S)	154	161	173
Hinson C 220/66 (S)	381	389	401
Johanna B 220/66 (S)	438	465	498
La Cienega 220/66 (S)	516	532	563
La Fresa B 220/66 (S)	725	768	821
Lewis 220/66 (S)	653	680	710

<b>LA Metro Area Coincident A-Bank Load Forecast (MW)</b>			
<b>Substation Load (1-in-10 Year)</b>			
<b>Substation</b>	<b>2015</b>	<b>2018</b>	<b>2023</b>
Lighthipe DEF 220/66 (S)	492	504	519
Mesa 220/66 (S)	670	683	715
Mira Loma 220/66 (S)	723	744	793
Moorpark C 220/66 (S)	833	867	923
Olinda 220/66 (S)	399	419	433
Padua 220/66 (S)	688	704	732
Rio Hondo 220/66 (S)	760	784	825
San Bernardino 220/66 (S)	649	683	728
Santa Clara 220/66 (S)	468	535	648
Santiago C 220/66 (S)	842	870	925
Saugus C 220/66 (S)	834	888	954
Valley AB 500/115 (S)	794	848	934
Valley C 500/115 (S)	1,004	718	794
Vernon	482	485	483
Viejo 220/66 (S)	361	371	375
Villa Park B 220/66 (S)	712	720	757
Vista 220/115 (S)	243	252	266
Vista C 220/66 (S)	599	624	659
Walnut 220/66 (S)	662	672	689
Wilderness 220/66 (F)	303	317	334

### **2.7.6.3 Assessment and Recommendations**

The ISO conducted detailed planning assessment based on the study methodology identified in section 2.3 to comply with the Reliability Standard requirements of section 2.2. Details of the planning assessment results are presented in Appendix B.

The reliability assessment identified several thermal loading concerns in the Metro area under Category B and C contingencies mainly because of the removal of OTC generating facilities from service in addition to SONGS. Following is a summary of the loading concerns identified.

#### 2015 Summer Peak

- None

#### 2018 Summer Peak

- Ellis–Santiago 230 kV line under Category C (L-1/L-1) contingencies.
- Ellis–Johanna 230 kV line under Category C (L-1/L-1) contingencies
- Chino–Mira Loma # 3 230 kV line under a Category C (T-1/T-1) contingency
- Serrano 500/230 kV Banks under Category C (T-1/T-1) contingencies

#### 2023 Summer Peak

- Barre–Lewis 230 kV line under a Category B (L-1) and multiple Category C (L-1/L-1) contingencies
- Vincent 500/230 kV #1 Bank under multiple Category B (L-1) and Category C (L-2, T-1/T-1) contingencies
- Barre–Villa Park 230 kV line under multiple Category C (L-1/L-1) contingencies
- Serrano–Villa Park #1 & #2 230 kV lines under multiple Category C (L-2) contingencies
- Lewis–Villa Park 230 kV line under a Category C (L-2) contingency
- Mira Loma 500/230 kV #1 & #2 Banks under a Category C (T-1/L-1) contingency
- Chino–Mira Loma # 3 230 kV line overload under a Category C (T-1/T-1) contingency
- Serrano 500/230 kV Banks overload under multiple Category C (T-1/L-1, T-1/T-1) contingencies

### **Request Window Proposals**

The ISO received proposals for the following reliability projects in the Metro area through the 2013 Request Window.

#### Ellis Corridor Upgrade

The project will upgrade Ellis-Santiago and Ellis-Johanna lines to their conductor rating by replacing terminal equipment at the three substations and increasing clearance on transmission spans along the two lines. The project was proposed by SCE to address the thermal overload of the Ellis-Santiago and Ellis-Johanna 230 kV lines that were identified in the ISO reliability assessment results. The estimated cost of the project is \$26 million. The proposed in-service date is June 1, 2015.

Mesa 500 kV Loop-in Project

The Mesa 500 kV Loop-in Project is described in more detail in section 2.6. The ISO notes that SCE proposed this project to address bulk system issues, and also to alleviate the increased overall loading on transmission facilities in the LA Metro area resulting from the retirement of SONGS and OTC generation as well as long term load growth in the LA Metro and San Diego areas. The proposed in-service date is December 31, 2020.

**ISO Assessment of Request Window Proposals**Ellis Corridor Upgrade Project

As discussed in section 2.6, the ISO agrees that the Ellis Corridor Upgrade Project addresses the thermal overloads on the Ellis-Santiago and Ellis-Johanna 230 kV lines. No other local issues were identified that were impacted by this project or other alternative mitigations, so this project is addressed exclusively in section 2.6.

Mesa 500 kV Loop-in Project

The ISO evaluated the performance of the local transmission system in the Metro area with the Mesa 500 kV Loop-in Project using the 2023 Summer Peak case. Table 2.7-13 provides the loading of the facilities identified above with and without the mitigations.

Table 2.7-13: 2023 Summer Peak loading of identified facilities with and without Mesa 500 kV Loop-in project

Facility	Contingency Type	Loading (%)	
		Without Mitigation	With Mitigation
Vincent 500/230 kV #1	A (N-0)	90%	61%
	C5	104%	65%
	C3 (T-1/T-1)	123%	81%
Barre–Lewis 230 kV	C3 (L-1/L-1)	104%	65%
Barre–Villa Park 230 kV	C3 (L-1/L-1)	93%	58%
Serrano–Villa Park #1 230 kV	C5	96%	75%
Serrano–Villa Park #2 230 kV	C5	91%	70%
Lewis–Villa Park 230 kV line	C5	102%	77%
Mira Loma 500/230 kV #1 or #2	C3 (T-1/L-1)	99%	82%
Chino–Mira Loma # 3 230 kV	C3 (T-1/T-1)	101%	86%
Serrano 500/230 kV	C3 (T-1/T-1)	121%	96%

This analysis supports the view that the Mesa Loop-in project along with the additional local capacity additions effectively alleviates the loading concerns identified in the Metro area because of the retirement of SONGS and OTC generation.

The ISO recognizes that the reliability needs of the LA Metro area are impacted by the amount and location of local capacity additions. The ISO will utilize the most current information from the LTPP process in its next transmission planning process cycle.

### **Recommendations**

The ISO conducted a detailed planning assessment for the LA Metro area to comply with the Reliability Standard requirements of section 2.2 and makes the following recommendations to address the reliability concerns identified:

- The ISO recommends operating solutions to address the overloads on Chino-Mira Loma #3 230 kV line and Serrano 500/230 kV transformers, which are caused by overlapping outages of transformers, in the short term.
- The Mesa 500 kV Loop-in project is discussed in additional detail and recommended in section 2.6.
- The Ellis Corridor Upgrade Project is discussed in additional detail in section 2.6 - the ISO proposes to re-evaluate the need for this project in the next planning cycle.

## 2.8 Valley Electric Association Local Area Assessment

### 2.8.1 Area Description

The existing Valley Electric Association (VEA) system consists of a 138 kV system that originates at the Amargosa Substation and extends to the Pahrump Substation and then continues into the VEA service area, the Pahrump-Mead 230 kV line, and a 230 kV transmission line from NVE's Northwest 230 kV substation to Desert View to Pahrump. This line provides a second 230 kV source into VEA's major system substation at Pahrump and forms a looped 230 kV supply source. With this new 230 kV line in service, the VEA system now has four

transmission tie lines with its neighboring systems, which are as follows:



- Amargosa-Sandy 138 kV tie line with WAPA;
- Jackass Flats-Lathrop Switch 138 kV tie line with Nevada Energy (NVE);
- Mead-Pahrump 230 kV tie with Western Area Power Administration (WAPA); and
- Northwest-Desert View 230 kV tie line with NVE.

### 2.8.2 Area-Specific Assumptions and System Conditions

The VEA area study was performed consistent with the general study methodology and assumptions described in section 2.3. The ISO-secured participant portal lists the base cases and contingencies that were studied as part of this assessment. In addition, specific assumptions and methodology that were applied to the Valley Electric Association area study are described below.

#### Transmission

In light of the FERC approved Transition Agreement between ISO and Valley Electric Association, the following major transmission projects are modeled in this planning cycle.

- VEA is planning a new 138 kV line from Charleston to Vista. This line will provide a looped supply source to the Charleston and Thousandaire substations, which comprise approximately one third of VEA's load and are currently radially supplied from Gamebird 138 kV substation. This line is expected to be in service by 2015.
- A new transmission interconnection tie between the VEA newly proposed 230 kV Bob Switchyard and the SCE new 220 kV Eldorado substation is planned by VEA and SCE and is assumed to be in service in 2015.
- A new Innovation-Mercury 138 kV transmission line and the Innovation 230/138-kV substation (formerly referred to as Sterling Mountain), which has been interconnected with the Desert View-Pahrump 230 kV line.

## Generation

There is no existing generation in the Valley Electric Association system. As described in section 2.3.2.5, some potentially planned renewable generation was modeled in the reliability cases.

## Load Forecast

The VEA Summer Peak base case assumes the CEC's 1-in-10 year load forecast. This forecast load includes system losses in the area. The VEA Summer Light Load and Off-Peak base cases assume 35 percent and 50 percent of the 1-in-10 year load forecast, respectively.

Table 2.8-1 provides a summary of the VEA area loads modeled in the Valley Electric Association area assessment.

Table 2.8-1: Summer Peak load forecasts

Substation	2015	2018	2023
Valley Electric Association area (MW)	147	151	217

### 2.8.3 Assessment and Recommendations

The ISO conducted detailed planning assessment based on the study methodology identified in section 2.3 to comply with the Reliability Standard requirements of section 2.2. Details of the planning assessment results are presented in appendix B. The reliability assessments identified various reliability concerns that require mitigation in the current planning cycle. The ISO recommends the following mitigations to ensure secure power transfer and adequate load serving capability of the transmission system;

- adjust taps on Eldorado and Amargosa transformers to mitigate high voltage issues under light-load conditions;
- an Operation Procedure to lock On-Load Tap Changer (OLTC) of the 138/24 kV transformers to avoid low voltage conditions at Innovation, Pahrump and Crazy Eyes 230 kV substations, after the first contingency under N-1-1 contingency of one of the two 230kV transmission sources;
- an operation procedure is recommended under first contingency of one of the two 230 kV transmission sources to properly operate the VEA 138 kV system in radial with three independent supplies from Jackass Flat, Amargosa, and the remaining 230 kV source in order to prepare second outage of remaining 230 kV transmission source; and
- an operating procedure to open Charleston-Thousandaire 138 kV line after the first contingency under N-1-1 outage of Pahrump-Vista 138kV line and Gamebird-Thousandaire 138 kV line.



## 2.9 San Diego Gas & Electric Local Area Assessment

### 2.9.1 Area Description

SDG&E is a public utility that provides energy service to 3.4 million consumers through 1.4 million electric meters and more than 840,000 natural gas meters in San Diego and southern Orange counties. The utility's service area encompasses 4,100 square miles from Orange County to the US-Mexico border.<sup>27</sup>



The SDG&E system including its main 500/230 kV system and 138/69 kV sub-transmission system, uses both imports and internal generation to serve the area load. The geographical location of the SDG&E system is shown in the adjacent illustration. The existing points of import are the South of San Onofre (SONGS)

transmission path (WECC Path 44), the Imperial Valley 500/230 kV substation, and the Otay Mesa-Tijuana 230 kV transmission line. In addition to imports, the SDG&E sub-transmission system is served by local generation.

The condition and needs of the SDG&E 500/230 kV system are presented in section 2.6 as part of the southern California bulk system. This section deals specifically with the local condition and needs of the SDG&E transmission system. This section addresses local system issues in the San Diego area with and without the recommended solutions set out in section 2.6 to ascertain the impact of those solutions on the local system and determine any additional mitigations required for local system concerns.

The SDG&E 500 kV system consists of the 500 kV Southwest Power Link (North Gila - Imperial Valley - Miguel) and the 500 kV Sunrise Power Link (Imperial Valley - Suncrest). Its 230 kV system extends from the Talega substation and SONGS in Orange County in the North to the Otay Mesa Substation in the South near the US-Mexico border and to the Suncrest and Imperial Valley substations in the east. 230 kV transmission lines form an outer loop located along the Pacific coast and around downtown San Diego. The SDG&E sub-transmission system consists of 138 kV and 69 kV transmission systems underlies the SDG&E 230 kV system from the San Luis Rey 230/138/69 kV Substation in the north to the South Bay (Bay Blvd) and Miguel substations in the south. There is also a radial 138 kV arrangement with seven substations interconnected to the Talega 230/138/69 kV Substation in Southern Orange County. Rural customers in the eastern part of San Diego County are served exclusively by a 69 kV system and often by long lines with low ratings.

### 2.9.2 Area-Specific Assumptions and System Conditions

The SDG&E area study was performed in accordance with the general study assumptions and methodology described in section 2.3. The ISO-secured website lists the study base cases and

<sup>27</sup> These numbers are provided by SDG&E in the 2011 Transmission Reliability Assessment

the contingencies that were evaluated as a part of this assessment. In addition, specific assumptions and methodology that applied to the SDG&E area study are provided below.

### **Generation**

The studies performed for the heavy summer conditions assumed all available internal generation was being dispatched at full output except for Kearney peakers, which were assumed to be retired beyond 2015. The Category B contingency studies were also performed for one generation plant being out-of-service. The largest single generator contingencies were assumed to be the whole Otay Mesa Energy Center or Palomar Energy Center. These two power plants are combined-cycle plants; therefore, there is a high probability of an outage of the whole plant. In addition to these generators, other generator outages were also studied.

Existing generation included all five Encina steam units, which were assumed to be available during peak loads in the 2015 base cases, but retired by the end of 2017 in light of the OTC schedule. A total of 946 MW of generating capacity can be dispatched based on the maximum capacity of each generating unit. Palomar Energy Center is owned by SDG&E and it began commercial operation in April 2006. This plant is modeled at 565 MW for the Summer Peak load reliability assessment.

The combined cycle Otay Mesa power plant started commercial operation in October 2009. It was modeled in the studies with the maximum output of 603 MW.

There are several combustion turbines in San Diego. Cabrillo II owns and operates all but two of the small combustion turbines in SDG&E's territory.

QFs were modeled with the total output of 180 MW. Power contract agreements with the QFs do not obligate them to generate reactive power. Therefore, to be conservative, all QF generation explicitly represented in power flow cases was modeled with a unity power factor assumption.

Existing peaking generation modeled in the power flow cases included the following: Calpeak Peakers located near Escondido (42 MW), Border (42 MW), and El Cajon (42 MW) substations; two Larkspur peaking units located next to Border Substation with summer capacity of 46 MW each; two peakers owned by MMC located near Otay (35.5 MW) and Escondido (35.5 MW) substations and two SDG&E peakers at Miramar Substation (MEF) (46 MW each). New peaking generation modeled in the studies included Orange Grove peakers and El Cajon Energy Center.

The Orange Grove project, composed of two units (94 MW total), is connected to the 69 kV Pala Substation and started commercial operation in 2010. The El Cajon Energy Center, composed of one 48 MW unit, is connected to the 69 kV El Cajon Substation and started commercial operation in 2010.

Renewable generation included in the model for all the study years are the 50 MW Kumeyaay Wind Farm that began commercial operation in December 2005, the 26 MW Boreggo Solar that started commercial operation in January 2013, and the 299 MW Ocotillo Express wind farm which became operational in December 2012. Lake Hodges pump-storage plant (40 MW) is composed of two 20 MW units. Both units are operational as of summer of 2012. Additional renewable generation was modeled in all study years based on CPUC's discounted core and

generation interconnection agreement status. These renewable generators were dispatched in all study years.

In addition to the generation plants internal to San Diego, 1,070 MW of existing thermal power plants is connected to the 230 kV bus of the Imperial Valley 500/230 kV Substation.

SONGS has been permanently retired and was not modeled in the base cases.

Table 2.9-1 lists a summary of the generation in the San Diego area, with detailed generation listed in Appendix A.

Table 2.9-1: San Diego area generation summary

<b>Generation</b>	<b>Capacity (MW)</b>
Thermal	3,015
Hydro	40
Wind	349
Solar	26
Biomass	24
<b>Total</b>	<b>3,454</b>

### Load Forecast

Loads within the SDG&E system reflect a coincident peak load for 1-in-10-year forecast conditions. The load for 2015 was assumed at 5,168 MW, and transmission losses were 189 MW. The load for 2018 was assumed at 5,492 MW, and transmission losses were 211 MW. The load for 2023 was assumed at 5,980 MW, and transmission losses were 226 MW. SDG&E substation loads were assumed according to the data provided by SDG&E and scaled to represent assumed load forecast. The total load in the power flow cases was modeled based on the load forecast by the CEC.

Table 2.9-2 summarizes load in SDG&E and the neighboring areas and SDG&E import modeled for the study horizon.

Table 2.9-2: Load, losses and import modeled in the SDG&amp;E study

PTO	2015		2018		2023	
	Load, MW	Losses, MW	Load, MW	Losses, MW	Load, MW	Losses, MW
SDG&E	5,168	189	5,492	211	5,980	226
SCE	25,039	492	26,062	520	27,584	633
IID	1019	39	1,130	58	1219	89
CFE	2,637	50	2,996	53	2946	41
SDG&E Import	2,906	-	2,900	-	3,242	-

Power flow cases for the study modeled a load power factor of 0.992 lagging at nearly all load buses in 2018 and 2023. The number was used because Supervisory Control and Data Acquisition (SCADA)-controlled distribution capacitors are installed at each substation with sufficient capacity to compensate for distribution transformer losses. The 0.992 lagging value is based on historical system power factor during peak conditions. The exceptions listed below were modeled using power factors indicative of historical values.

- Naval Station Metering (bus 22556): 0.707 lagging (this substation has a 24 MVar shunt capacitor);
- Descanso (bus 22168): 0.901 leading.

This model of the power factors was consistent with the modeling by SDG&E for planning studies. Periodic review of historical load power factor is needed to ensure that planning studies utilize realistic assumptions.

### Energy Efficiency

Additional Achievable Energy Efficiency or AAEE was also assumed and modeled for the studies. These assumptions are consistent with the assumptions from the CPUC Long Term Procurement Plan Track 4 studies. Table 2.9-3 summarizes the AAEE assumed for the SDG&E local area.

Table 2.9-3: Projected Additional Achievable Energy Efficiency

PTO	2015	2018	2023
	AAEE	AAEE	AAEE
SDG&E	-57	-103	-197

### 2.9.3 Assessments and Recommendations

The ISO conducted a detailed planning assessment based on the study methodology identified in section 2.3 to comply with the Reliability Standard requirements of section 2.2. Details of the planning assessment results are presented in Appendix B.

In response to the ISO study results and proposed alternative mitigations, twenty-three reliability project submissions were received through the 2013 Request Window. Out of these projects, some were alternatives for solving the same problems and/or targeting the Southern California Bulk Transmission System.

The ISO investigated various transmission upgrade mitigations including alternatives, and recommends a total of nine transmission mitigations to address identified local reliability concerns in the SDGE transmission system which are summarized below and described in greater detail in Appendix A.

The ISO also demonstrated that five of the submitted projects can be postponed by energy efficiency, distributed generation, and demand response programs initiated by the CEC and CPUC. In addition, the ISO recommends putting distribution capacitor banks in automatic mode of operation to maintain unity power factors on the distribution side, and rely on operation procedures as needed to address the voltage concerns identified on various 69 kV buses of the local 69 kV network. SDG&E will continue to investigate and alleviate the voltage concerns by possibly adopting higher voltage deviation criteria as a solution on a case-by-case basis. The ISO will continue to monitor and assess sub-transmission voltage support in future planning cycles.

Below are the nine transmission development projects to address the local SDG&E reliability concerns that the ISO recommends in the 2013-2014 transmission planning process:

#### Miguel 500 kV Voltage Support

Install up to 375 MVAR of reactive support (i.e., shunt capacitors) at Miguel substation to mitigate low voltage conditions at Miguel and ECO 500kV buses under normal summer peak load conditions. This amount of reactive support will improve the voltages to about 515kV and 513kV for summer 2018 and 2023 peak load conditions. The estimated cost of the project is about \$30~40 million. The proposed in-service date is June 1, 2017.

#### TL13834, Trabuco-Capistrano 138 kV Line Upgrade

This 3.7 miles section is expected to be overloaded for losing L-1-1 contingency of losing TL13833 Talega-Rancho Mission Viejo and TL13833 Trabuco-Capistrano 138 kV lines after the South Orange County Reliability Enhancement (SOCRE) Project is completed. The limiting equipment for TL13834 is at Capistrano 138 kV Substation with both a jumper and CT rated at 158 MVA. SDG&E commits to use its SOCRE program to upgrade the terminal equipment and make the line rated at 274 for both normal and emergency conditions. The ISO endorses the cost-effective mitigation. The estimated cost of the project is under \$1 million. The proposed in-service date is June 1, 2018.

Miramar-Mesa Rim 69 kV System Reconfiguration

TL6916 Sycamore-Scripps 69 kV line is expected to be overloaded for the L-1-1 outage of losing a new Sycamore-Penasquitos and Miguel-South Bay 230 kV lines. The ISO identified the overload and SDG&E submitted a mitigation to eliminate the overload by re-configuring the Penasquitos-Mesa Rim-Miramar 69 kV system. The re-configuration will re-direct the flow out of Miramar Peakers, and alleviate the flow penetrating through the Sycamore-Scripps-Miramar-Penasquitos 69 kV system. The re-arrangement is a cost-effective reliability project with minimum environment permitting requirement. The ISO verified that the re-configuration will be effective to eliminate the overload after the transmission mitigation plan discussed in chapter 2.6 is in service. The estimated cost of the project is \$5~7 million. The proposed in-service date is June 1, 2018.

Artesian 230/69 kV Sub and loop-in

One of the three Banks overloaded for the other two banks out of service (T-1-1) by the year of 2018. Poway-Pomerado 69 kV line is also expected to be heavily loaded and overloaded for a N-2 outage of Sycamore-Penasquitos and Sycamore-Palomar 230 kV lines, and a L-1-1 outage of Sycamore-Penasquitos and Miguel-South Bay 230 kV lines. The ISO recommends to upgrade Artesian 69 kV substation to a 230/69 kV substation and loop it into TL23051 Sycamore-Palomar 230 kV line nearby and make re-arrangement to develop two 69 kV lines between the Bernardo and Artesian 230/69 kV substations. The new Artesian 230/69 kV substation will provide a third 230 kV transmission source to the Poway load pocket which will improve the reliability for the pocket. With this mitigation approved, SDG&E does not need to continue its process to implement the Sycamore-Bernardo 69 kV line reliability project that was approved by the ISO in the 2012-2013 transmission planning process. The estimated cost of the project is \$44~64 million. The proposed in-service date is June 1, 2016.

Sycamore-Bernardo 69 kV project replaced by Bernardo-Ranche Carmel-Poway 69 kV lines upgrade

With the Artesian 230/69 kV Sub and loop-in project approval, SDG&E submitted a request to withdraw the Sycamore-Bernardo 69 kV line (TL6961) project that was previously approved in the 2010/11 planning cycle, instead, to propose a cost-effective upgrade to re-conductor Bernardo-Rancho Carmel and Rancho Carmel-Poway 69 kV lines as a replacement. The request will also avoid complexity of the permitting process, alleviate congested corridor with multiple lines, minimize double circuit structures, and bring in some cost saving benefit. The ISO endorses the request to stop the process implementing Sycamore-Bernardo 69 kV line project (\$43 millions), and replace it with Bernardo-Ranche Carmel & Rancho Carmel-Poway 69 kV lines upgrade (\$28 millions). This will save about \$15 million. The proposed in-service date is June 1, 2016.

TL690A/TL690E, San Luis Rey-Oceanside Tap and Stuart Tap-Las Pulgas 69 kV sections re-conductor

TL690E section overloaded for various Category B and Category C contingencies, including the loss of Talega Bank50, TL695, or TL23052 starting from the year 2015. TL690A section overloaded for Category B contingency of TL697 San Luis Rey-Oceanside 69 kV line. The ISO

recommends to re-conductor TL690A and TL690E sections to a higher capacity conductor, which also requires replacing the aged wood structures with steel structures. The ISO notes that TL 690 is part of SDG&E's fire hardening project, in which SDG&E would otherwise replace the aged wood pole structures with steel poles but keep the same conductor. The estimated cost of the project is \$24~28 million. The proposed in-service date is June 1, 2015.

Mission Bank #51 and #52 replacement

The ISO identified the Mission Bank #51 overload for losing Bank #50&52 (T-1-1) in the Mission 138/69 kV substation. The ISO recommends to install a new 230/69 kV transformer in the Mission 230/138/69 kV substation. With the new 230/69 kV transformer in service, SDG&E will be able to salvage the aged Banks #51 and #52 in the Mission 139/69 kV substation. The estimated cost of the project is \$10 million. The proposed in-service date is June 1, 2018.

Rose Canyon-La Jolla 69kV T/L

The ISO identified the Rose Canyon-Rose Canyon Tap 69 kV section overload for Category B contingency of TL613 Old Town-Pacific Beach 69 kV line. SDG&E submitted a project get rid of Rose Canyon Tap and create new Rose Canyon-La Jolla and Pacific Beach-Rose Canyon 69 kV lines. The ISO endorses the mitigation as reliability project in this planning cycle. The estimated cost of the project is \$3.2~4 million. The proposed in-service date is June 1, 2018.

2nd Escondido-San Marcos 69 kV T/L

The ISO identified the TL684 Escondido-San Marcos 69 kV line overloaded for the Category C contingency of Escondido-Talega and Encina-Encina Tap- Palomar 230 kV lines based on the supplemental Post-SONGS base case starting from the 2018 base case. In the history of the ISO day-ahead market, high post-contingency flows on TL684 were identified eleven times since June 2012, which resulted in generation re-dispatched to reduce northbound flow to the LA Basin area or the opening of TL684 to make about 80~100 MW customer loads at San Marcos substation left on a radial feed supplied by a single 69 kV source. SDG&E proposed to energize an abandoned 138 kV line and make it 2nd 69 kV line between Escondido and San Marcos. The ISO also verified that the project will be effective to eliminate the overload and the day-ahead market issue after the Southern California Bulk System mitigation plan described in section B3 is in service. The ISO recommends creating this second 69 kV line no later than June 2018 as a reliability project. The project in-service date can be pushed forward to June 2015 to eliminate the day-ahead market congestion issue for economic and operation benefit. The estimated cost of the project is \$18~22 million.

**Intentionally left blank**



## Chapter 3

### 3 Special Reliability Studies and Results

#### 3.1 Overview

The special studies discussed in this chapter have not been addressed elsewhere in the transmission plan. The studies are the Reliability Requirements for Resource Adequacy and the Review of Existing SPS Studies.

#### 3.2 Reliability Requirement for Resource Adequacy

Sections 3.2.1 and 3.2.2 summarize the technical studies conducted by the ISO to comply with the reliability requirements initiative in the resource adequacy provisions under Section 40 of the ISO tariff. The local capacity technical analysis addressed the minimum local capacity requirements (LCR) on the ISO grid. The Resource Adequacy Import Allocation study established the maximum resource adequacy import capability to be used in 2014.

##### 3.2.1 Local Capacity Requirements

The ISO conducted short- and long-term local capacity technical (LCT) analysis studies in 2013. A short-term analysis was conducted for the 2014 system configuration to determine the minimum local capacity requirements for the 2014 resource procurement process. The results were used to assess compliance with the local capacity technical study criteria as required by the ISO tariff section 40.3. This study was conducted January-April through a transparent stakeholder process with a final report published on April 30, 2013. A long-term analysis was also performed to identify local capacity needs in the 2018 period and published on April 30, 2013. The long-term analysis provides participants in the transmission planning process with future trends in LCR needs for up to five years. This section summarizes study results from both studies.

As shown in the LCT reports and indicated in the LCT manual, 11 load pockets are located throughout the ISO-controlled grid as shown in and illustrated in figure 3.2-1 below.

Table 3.2-1: List of LCR areas and the corresponding PTO service territories within the ISO BAA area

No	LCR Area	PTO Service Territory
1	Humboldt	PG&E
2	North Coast/North Bay	
3	Sierra	
4	Stockton	
5	Greater Bay Area	
6	Greater Fresno	
7	Kern	
8	Los Angeles Basin	SCE
9	Big Creek/Ventura	
10	Greater San Diego/Imperial Valley	SDG&E
11	Valley Electric	VEA

Figure 3.2-1: Approximate geographical locations of LCR areas



Each load pocket is unique and varies in its capacity requirements because of different system configuration. For example, the Humboldt area is a small pocket with total capacity requirements of approximately 200 MW. In contrast, the requirements of the Los Angeles Basin are approximately 10,000 MW. The short- and long-term LCR needs from this year's studies are shown in the table below.

Table 3.2-2: Local capacity areas and requirements for 2014 and 2018

LCR Area	Existing LCR Capacity Need (MW)	
	2014	2018
Humboldt	195	197
North Coast/North Bay	623	424
Sierra	1,803	1,114
Stockton	446	374
Greater Bay Area	4,423	4,478
Greater Fresno	1,857	2,110
Kern	421	421
Los Angeles Basin	10,430	11,071
Big Creek/Ventura	2,250	2,688
Greater San Diego/Imperial Valley	3,605	3,310
Valley Electric	0	0
<b>Total</b>	<b>26,053</b>	<b>26,187</b>

For more information about the LCR criteria, methodology and assumptions please refer to the ISO website. (A link is provided [here](#)).

For more information about the 2014 LCT study results, please refer to the reports posted on the ISO website. (Links are provided [here](#)).

For more information about the 2018 LCT study results, please refer to the [report](#) posted on the ISO website.

### 3.2.2 Resource Adequacy Import Capability

The ISO has established the maximum RA import capability to be used in year 2014 in accordance with ISO tariff section 40.4.6.2.1. These data can be found on the ISO website. (A link is provided [here](#)). The entire [2014 import allocation process](#) is posted on the ISO website.

The ISO has established in accordance with Reliability Requirements BPM section 5.1.3.5 the target maximum import capability (MIC) from the Imperial Irrigation District (IID) to be 1,400 MW in year 2020 to accommodate renewable resources development in this area. This was based on the direction from the CPUC instructed PG&E, SCE and/or SDG&E to consider import capacity for RA to not be not less than 1400 MW total for purposes of evaluating renewable generation resources in the 2011 RPS solicitation that was underway, in an Assigned Commissioner Ruling dated June 7, 2011 in the Order Instituting Rulemaking to Continue Implementation and Administration of California Renewables Portfolio Standard Program (May 5, 2011). The import capability from IID to the ISO is the combined amount from the IID-SCE\_BG and the IID-SDGE\_BG.

The 10-year increase in MIC from current levels out of the IID area is dependent on transmission upgrades in both the ISO and IID areas as well as new resource development within the IID and ISO systems. Previous transmission plans indicated that increases from the existing level to targeted levels were dependent upon previously identified transmission reinforcements.

During this year's studies concerns have been identified regarding deliverability of generation in Imperial Valley area on San Diego's transmission system, due to SONGS retirement. (Please refer to Section 4.3.) The ISO is recommending transmission solutions in this transmission plan that, together with the previously identified projects, are expected to restore much of the targeted MIC by 2020. These projects enable an additional 1000 MW of renewable generation in the Imperial Valley area. Assuming these projects are completed on schedule, the MIC from IID for 2020, absent any further upgrades, would consist of the existing 462 MW plus the 1,000 MW of additional deliverability from the Imperial Valley Zone less generation in the zone that has connected directly to the ISO footprint since the study assumptions were set. However, the ISO is planning to identify further upgrades, as part of the 2014-2015 transmission planning process that would be required to achieve the original 1,400 MW MIC target for IID. As part of this planning cycle, the ISO has conducted an initial assessment of transmission projects that would likely provide full deliverability for Imperial zone portfolio however due to the magnitude of the deliverability deficiencies and the significant costs and feasibility challenges of the various transmission options, further analysis is needed in the next transmission planning process to develop the most cost effective comprehensive transmission plan for this area. Therefore, the timing of transitioning from the current level of 462 MW to the targeted level is uncertain until the necessary mitigations can be planned and approved<sup>28</sup>.

---

<sup>28</sup> Indicative information will be available through the operational studies prepared as part of GIDAP in December 2014, as the ISO queue volumes studied in that work are larger than the target import capability from IID. The deliverability issues affect imports from IID or new generation connecting directly to the ISO controlled grid in the area equally.

The ISO also confirms that all other import branch groups or sum of branch groups have enough MIC to achieve deliverability for all external renewable resources in the base portfolio along with existing contracts, transmission ownership rights and pre-RA import commitments under contract in 2023.

The future outlook for all remaining branch groups can be accessed at the following link:

<http://www.caiso.com/Documents/Advisory%20estimates%20of%20future%20resource%20adequacy%20import%20capability>.

### 3.3 Review of Existing SPS

Within the ISO controlled grid there are a significant number of special protection systems (SPS) in operation. These SPS are related to a wide variety of system operating conditions such as bulk system performance requirements, local area performance requirements and generator interconnections.

The ISO reviewed the bulk of the existing SPS in a comprehensive effort in the 2012-2013 transmission plan. This included extensive documentation, performing functional reviews, and screening the SPS for those requiring further review by PTOs (Stage 3 review). However, completion of the review of existing SPS required further efforts in the 2013-2014 cycle to review SPS that were identified as needing further analysis, to address lower priority SPS that were not addressed last year, and to address other gaps that were identified in last year's efforts. The work completed in 2013-2014 planning cycle included the following:

- updated 2012 SPS reviews, as needed, based on findings from 2013-2014 cycle reliability assessment.
- performed required studies to complete recommendation for the seven SPS reviewed but identified as needing further study.
- reviewed remaining SPS that were lower priority.
- obtained documentation and reviewed the two SPS lacking documentation.
- reviewed new SPS implemented through the generator interconnection process.

The review objective was to ensure the SPS met the current and future system needs. The following provides the steps taken in conducting this review of existing SPS.

- documented the list of existing SPS in the ISO controlled grid;
- identified for each SPS the associated contingency, action initiated, load drop, generation drop, arming, complexity, security, consequences if fail to operate.
- developed criteria for design and protection coordination review.
- Performed functional review of existing SPS
  - Is functionality current, and does the SPS meet current criteria?
  - Even if so, is the risk of system impact acceptable?

The review considered SPS performance, operation and design and the effects of planned transmission developments and changes in transmission use and risk tolerance.

The review was done in two stages with a stage 1 analysis that covered documentation and stage 2, which is a functional review.

Once the analysis is completed, there are several options for action that including the following:

- leaving the SPS in place as is;
- removing the SPS from service;
- modifying functionality of the existing SPS; or
- replacing the existing SPS with a transmission capital solution.

Table 3.3-1 summarizes the recommendations for each SPS reviewed and updated as a part of the 2013-2014 transmission planning process.

Table 3.3-1: Summary of recommendations for each SPS

SPS Name	PTO	Area	Recommendation
Colusa SPS	PG&E	Bulk	Needed based on 2013-2014 reliability assessment. Leave in place.
Mesa and Santa Maria Under-voltage SPS	PG&E	Central Coast / Los Padres	Doesn't mitigate all intended reliability concerns. Modify the SPS. Not needed after Midway-Andrew 230 kV project is implemented.
Divide Undervoltage SPS	PG&E	Central Coast / Los Padres	Needed based on 2013-2014 reliability assessment. Leave in place until Midway-Andrew 230 kV project is implemented.
Temblor-San Luis Obispo 115 kV Overload Scheme	PG&E	Central Coast / Los Padres	Doesn't mitigate all intended reliability concerns. Needs to be modified.
Midway 500/230 kV Transformer Overload SPS	PG&E	Bulk	Needed during low load and high Carrizo area generation condition. Leave in place.
Metcalf SPS	PG&E	Bulk	Needed during high generation at Moss Landing and low generation at Metcalf and Los Esteros. Leave in place.
Drum (Sierra Pacific) Overload Scheme (Path 24)	PG&E	Central Valley	Needed under extreme Path 24 flow conditions. Leave in place.
Metcalf-Monta Vista OL SPS	PG&E	Bay Area	Needed based on 2013-2014 reliability assessment. Leave in place.
San Mateo-Bay Meadows 115 kV line OL	PG&E	Bay Area	No need identified in 2013-2014 reliability assessment. SPS not needed.
South of San Mateo SPS	PG&E	Bay Area	No need identified in 2013-2014 reliability assessment. Not needed for the facilities currently monitored. Could possibly be used as a safety net with in the Bay Area.
Henrietta RAS	PG&E	Fresno / Kern	Needed based on 2013-2014 reliability assessment. Leave in place.



500 kV RAS Tables	PG&E	Bulk	The 500 RAS Tables are a part of the COI RAS, which was reviewed in the 2012-2013 Transmission Plan and is needed. Leave in place.
Bahia – Valero SPS	PG&E	North Coast / North Bay	Needed for continued reliable operation of the Valero generation. Leave in place.
Hat Creek-Westwood OL Scheme	PG&E	North Valley	Needed during low level of local area generation and when Chester and Hamilton Branch loads are picked-up when Westwood is on alternate source from Hat Creek. Leave in place and cut-in on an as needed basis.
Plumas Separation Scheme	PG&E	North Valley	Needed based on 2013-2014 reliability assessment. Leave in place.
Weber TB #2 & 2A 60 kV regulator OL	PG&E	Central Valley	Needed based on 2013-2014 reliability assessment. Leave in place until Weber 230/60 kV transformer replacement project is implemented.
Yuba City Energy Center SPS	PG&E	Central Valley	Needed during low load and high level of generation in Pease 60 kV system. Leave in place and cut-in on an as needed basis.
Coppermine RAS	PG&E	Fresno / Kern	Needed during non-peak periods when the line is closed through and load is low in the area. As such, the recommendation for this SPS is to leave in place and cut-in on an as needed basis.
Exchequer RAS	PG&E	Fresno / Kern	Needed to avoid overload of underlying 70kV system due to over-generation of Exchequer PH. Leave in place.
Kings River Anti-Islanding SPS	PG&E	Fresno / Kern	Needed to prevent islanding at Kings River and Malaga. Leave in place.
Schulte Sw Sta–Manteca 115kV Line Thermal Overload Scheme	PG&E	Central Valley	Needed during low level of generation in Tesla 115 kV system. Leave in place and cut-in on an as needed basis.
Contra Costa-Moraga 230 kV Lines Interim SPS	PG&E	Bay Area	Needed based on 2013-2014 reliability assessment. Leave in place until Contra Costa-Moraga 230 kV lines reconducting project is implemented.

Carrizo SPS: Carrizo SPS Transient Voltage Dip Criteria Deviation Scheme, Carrizo SPS Overload Scheme and Midway Bank Overload Scheme	PG&E	Central Coast / Los Padres	The Carrizo SPS Transient Voltage Dip Criteria Deviation Scheme and Midway Bank Overload Scheme are needed. The Carrizo SPS Overload Scheme needs modification to coincide with the Midway-Temblor 115 kV reconductoring project.
Victor Direct Load Tripping Scheme (DLTS) – SCE SOB-283, Appendix A	SCE	North of Lugo	The need for this SPS is evident for the N-2 contingency of Lugo – Victor 230kV lines #1 and #2 and hence the recommendation is to leave in place.
West-of-Devers Remedial Action Scheme	SCE	Eastern Area	The RAS continues to be needed. It has been redesigned in connection with generation project in the area.
Blythe Energy RAS Overload Scheme	SCE	Eastern Area	The RAS continues to be needed. It is being modified in connection with the rating increase of the Julian Hinds 230 kV bus section.
El Segundo N-2 Remedial Action Scheme	SCE	Metro Area	Needed to avoid overload on the El Nido–La Cienega 230 kV line. Should be revisited when El Segundo #4 OTC generating unit is retired.
TL695A at Talega SPS	SDG&E	SDG&E	The recommendation is to leave in place. The Stuart Tap-Las Pulgas 69 kV line overloads as an unintended consequences of the SPS operation, which will be mitigated by the TL690A and TL690E (San Luis Rey-Oceanside Tap & Stuart Tap-Las Pulgas 69 kV lines) re-conductoring project with in-service date of June 2015 (recommended in the 2013~2014 TPP process). In addition, it is recommended to re-evaluate the Talega TL695 SPS by the time the TL695 re-conductoring project is in service in 2014.
TL682/TL685 SPS	SDG&E	SDG&E	The recommendation is to leave in place. However, threshold of the TL685 SPS to trip TL682C at WR should be modified to 45 MVA from its current 26 MVA as the emergency rating of TL 685 has been updated to 45 MVA from 26 MVA.

TL633 At Rancho Carmel SPS	SDG&E	SDG&E	The recommendation is to leave in place until the TL633 upgrade project is completed. However, the current rating of TL633 has to be verified and the SPS modified if the rating is 68 MVA rather than 79 MVA. By the time the TL633 upgrade project is done, the SPS needs to be modified to cover an overload on Bernardo-Felicita 69 kV line (TL689) for the Poway south 69 kV bus outage(Category C).
TL687 at Borrego SPS	SDG&E	SDG&E	This SPS is currently disabled and the cutout switches are turned off. The need to re-activate the SPS is not evident and hence the recommendation is to leave it as disabled.
TL13816 SPS	SDG&E	SDG&E	The SPS is needed in case of extreme high load condition and hence the recommendation is to re-activate it by the summer of 2014.
TL13835 SPS	SDG&E	SDG&E	The SPS is needed during heavy load conditions until the completion of the South Orange County 230 kV upgrade project. But the SPS has to be modified and corrected to avoid unintended cascading event in the South Orange County 138 kV system.
Border TL649 Overload SPS	SDG&E	SDG&E	The recommendation is to leave it in place.
Crestwood TL626 at DE SPS for Kumeyaay Wind generating	SDG&E	SDG&E	The recommendation is to leave it in place. Needs to be modified after the completion of the Barrett Tap 69 kV removal project.
Crestwood TL629 at CN SPS for Kumeyaay Wind generating	SDG&E	SDG&E	The recommendation is to leave it in place.
Crestwood TL629 at DE SPS for Kumeyaay Wind generating	SDG&E	SDG&E	The recommendation is to leave it in place until the completion of the Barrett Tap 69 kV removal project. Then SPS needs to be modified.

**Intentionally left blank**

## Chapter 4

# 4 Policy-Driven Need Assessment

## 4.1 Study Assumptions and Methodology

### 4.1.1 33% RPS Portfolios

On February 7, 2013 the California Energy Commission and the California Public Utilities Commission recommended renewable resource portfolios for the ISO's 2013-2014 transmission planning process<sup>29</sup>. These renewable resource portfolios demonstrated tremendous progress made towards meeting California's 33% Renewables Portfolio Standard (RPS). The renewable net short energy calculation dropped from 45,000 GWh to 32,000 GWh, a reduction of nearly 30 percent. Thousands of megawatts of clean, renewable generation from both small and large-scale generators interconnected to California's grid in recent years, with an increasing amount of renewable generation expected to come online over the next several years.

As with the 2012-2013 Transmission Plan, the "commercial interest" portfolio was identified as the appropriate base case for the ISO to study in its 2013-2014 transmission planning process since it represents the most likely path of renewable development in the future. The "commercial interest" portfolio heavily weights projects with an executed or approved power purchase agreement and data adequacy for a major siting application. The CPUC and CEC also highly recommended that the ISO study the two sensitivity scenario portfolios in its 2013-2014 transmission planning process: (1) an "environmental" portfolio, which heavily weights the positive environmental attributes of projects and (2) a "high distributed generation (DG)" portfolio.

The base and sensitivity scenarios were used by the ISO to perform a least regrets transmission need analysis as described in tariff section 24.4.6.6. The ISO and CPUC worked together to model the proposed renewable portfolios into the transmission planning base cases.

The installed capacity and energy per year of each portfolio by location and technology are shown in the following tables.

---

<sup>29</sup> <http://www.caiso.com/Documents/2013-2014RenewablePortfoliosTransmittalLetter.pdf>

Table 4.1-1: Commercial interest portfolio — base portfolio (MW)

Zone	Biogas	Biomass	Geothermal	Hydro	Large Scale Solar PV	Small Solar PV	Solar Thermal	Wind	Grand Total
Alberta								450	450
Arizona					550				550
Carrizo South					900				900
Central Valley North		0			25				25
Distributed Solar - PG&E						984			984
Distributed Solar - SCE						565			565
Distributed Solar - SDGE						143			143
El Dorado					150		407		557
Imperial	15		403		1015	30		252	1715
Kramer			64		320	72	250	56	762
Los Banos					370				370
Merced	5				57				62
Mountain Pass					300		345		645
Nevada c			166						166
NonCREZ	104	52	15	0		2			173
Northwest								104	104
Riverside East					800	9	400		1209
Round Mountain		0							0
San Bernardino - Lucerne								42	42
Solano	3				30			167	200
Tehachapi	10				911	110		1070	2101
Westlands		5			108	121			233
<b>Grand Total</b>	<b>136</b>	<b>57</b>	<b>648</b>	<b>0</b>	<b>5535</b>	<b>2034</b>	<b>1402</b>	<b>2142</b>	<b>11954</b>

Table 4.1-2: Environmentally Constrained portfolio (MW)

Zone	Biogas	Biomass	Geothermal	Hydro	Large Scale Solar PV	Small Solar PV	Solar Thermal	Wind	Grand Total
Alberta								450	450
Arizona					550				550
Carrizo South					900				900
Central Valley North		18			155				173
Distributed Solar - PG&E						1529			1529
Distributed Solar - SCE						1255			1255
Distributed Solar - SDGE						190			190
El Dorado					150		407		557
Imperial	15		30		535	30		265	875
Kramer						20	42		62
Los Banos									
Merced	5				57				62
Mountain Pass					300		345		645
Nevada c			166						166
NonCREZ	110	180	15	21		2			328
Northwest								104	104
Riverside East					900	9	400		1309
Round Mountain		34							34
San Bernardino - Lucerne								42	42
Solano									
Tehachapi	10				986	150		1110	2256
Westlands		5			1056	309			1370
<b>Grand Total</b>	<b>139</b>	<b>237</b>	<b>211</b>	<b>21</b>	<b>5589</b>	<b>3494</b>	<b>1194</b>	<b>1971</b>	<b>12855</b>

Table 4.1-3: High DG portfolio (MW)

Zone	Biogas	Biomass	Geothermal	Hydro	Large Scale Solar PV	Small Solar PV	Solar Thermal	Wind	Grand Total
Alberta								450	450
Arizona					550				550
Carrizo South					300				300
Central Valley North		0			25				25
Distributed Solar - PG&E						3449			3449
Distributed Solar - SCE						2345			2345
Distributed Solar - SDGE						157			157
El Dorado					150		407		557
Imperial	15		30		616	30		184	875
Kramer						40	22		62
Los Banos									
Merced	5				57				62
Mountain Pass					300		345		645
Nevada c			166						166
NonCREZ	104	52	15	0		2			173
Northwest								104	104
Riverside East					800	9	400		1209
Round Mountain		0							0
San Bernardino - Lucerne								42	42
Solano									
Tehachapi	10				911	110		1070	2101
Westlands		5			108	121			233
<b>Grand Total</b>	<b>133</b>	<b>57</b>	<b>211</b>	<b>0</b>	<b>3816</b>	<b>6263</b>	<b>1174</b>	<b>1850</b>	<b>13504</b>



#### **4.1.2 Assessment Methods for Policy-Driven Transmission Planning**

NERC and WECC reliability standards and ISO planning standards were followed in the policy-driven transmission planning study, which are described in chapter 2 of this plan. Power flow contingency analysis, post transient voltage stability analysis, and transient stability analysis, were performed as needed to update policy driven transmission need analysis on the renewable portfolios performed in the previous three ISO transmission plans. The contingencies that were used in the ISO annual reliability assessment for NERC compliance were revised as needed to reflect the network topology changes and were simulated in the policy-driven transmission planning assessments.

Generally, Category C3 overlapping contingencies (e.g., N-1 followed by system adjustments and then another N-1) were not assessed in this assessment. In all cases, curtailing renewable generation following the first contingency can mitigate the impact of renewable generation flow prior to the second contingency. Given high transmission equipment availability, the amount of renewable energy expected to be curtailed following transmission outages is anticipated to be minimal.

Overlapping contingencies that could reasonably be expected to result in excessive renewable generation curtailments were assessed. Outages that potentially impact system-wide stability were extensively simulated and investigated. The existing SPS were evaluated using the base cases to ensure that they do not need to be redesigned. The assessments that have been performed include, but not limited to post transient voltage stability and reactive margin analyses and time-domain transient simulations. Power flow studies following the ISO generator deliverability assessment methodology were also performed.

Mitigation plans have been developed for the system performance deficiencies identified in the studies and the plans were investigated to verify their effectiveness. Multiple alternatives were compared to identify the preferred mitigations. If a concern was identified in the ISO Annual Reliability Assessment for NERC Compliance but was aggravated by renewable generation, then the preliminary reliability mitigation was tested to determine if it lessened the more severe problem created by the renewable generation. Other alternatives were also considered. The mitigation plan recommendation, which may have been the original one or an alternative, was then included as part of the comprehensive plan.

##### **4.1.2.1 Production Cost Simulation**

The production cost simulation results were used to identify generation dispatch and path flow patterns in the 2023 study year after the renewable portfolios were modeled in the system. Generation exports from renewable generation study areas were monitored as well as major transfer path flows. The ISO unified economic assessment database, which is based on the TEPPC Economic Assessment database, was used as the starting database. Production cost simulations were performed for all three renewable portfolios. This information was used to identify high transmission system usage patterns during peak and off-peak load conditions. Selected high transmission usage patterns were used as reference in the power flow and stability base case development.

### 4.1.3 Base Case Assumptions

#### 4.1.3.1 Starting Base Cases Comparison of All Portfolios

The consolidated peak and off-peak base cases for 2023 in the ISO Annual Reliability Assessment for NERC Compliance were used as the starting points for developing the base cases used in the policy-driven transmission planning study.

#### 4.1.3.2 Load Assumptions

In accordance with the ISO planning standards for studies that address regional transmission facilities, such as the design of major interties, a 1-in-5 year extreme weather load level was assumed. An analysis of the RPS portfolios to identify policy-driven transmission needs is a regional transmission analysis. Therefore, the 1-in-5 coincident peak load has been used for the policy-driven transmission planning study. A typical off-peak load level on the ISO system is approximately 50 percent of peak load. Therefore, the load level that is 50 percent of the 1-in-5 peak load is selected as the reference of the off-peak load condition as show in Table 4.1-4.

Table 4.1-4: Load condition by areas

Area in Base Cases	1-in-5 coincident peak load (MW)
Area 30 (PG&E)	30,817
Area 24 (SCE)	27,328
Area 22 (SDG&E)	5,913
VEA	169

#### 4.1.3.3 Conventional Resource Assumptions

Conventional resource assumptions were the same as in the reliability assessment. Details can be found in chapter 2.

#### 4.1.3.4 Transmission Assumptions

Similar to the ISO's Annual Reliability Assessments for NERC Compliance, all transmission projects approved by the CPUC and ISO were modeled in the base cases. Details can be found in chapter 2.

## **4.1.4 Power Flow and Stability Base Case Development**

### **4.1.4.1 Modeling Renewable Portfolio**

#### **4.1.4.1.1 Power Flow Model and Reactive Power Capability**

As discussed in section 4.1.1, CPUC and CEC renewable portfolios were used to represent RPS portfolios in the policy-driven transmission planning study. The commissions have assigned renewable resources geographically by technology to CREZs and non-CREZ areas, and to specific substations for some distributed generation resources. Using the provided locations, the ISO represented renewable resources in the power flow model based on information from generator interconnection studies performed by the ISO and utilities. The objective of modeling generation projects this way is not meant to endorse any particular generation project, but rather to streamline and focus the transmission analysis on least regrets transmission needs. In other words, transmission needs associated with a specific generation project development scenario within a renewable resource area, but not needed by an alternative generation project development scenario within the same area would be a localized transmission need to be addressed in the interconnection study process and would not be a least regret transmission need to be addressed in the transmission planning process.

If modeling data from ISO or PTO generation interconnection studies were used, they included the reactive power capability (the minimum and the maximum reactive power output). If modeling data came from other sources, an equivalent model was used that matches the capacity as listed in the portfolios. When an equivalent model was used for large scale wind turbine or solar PV generation, it was assumed that the generation could regulate bus voltage utilizing a power factor range of 0.95 lagging to leading. Unity power factor was assumed for solar PV distributed generation. For all other new generation modeled, typical data was used in the equivalent model with a power factor range of 0.90 lagging and 0.95 leading.

#### **4.1.4.1.2 Dynamic Modeling of Renewable Generators**

Similar to the power flow model, if the modeling data came from the ISO or PTO generation interconnection studies, then the dynamic models from the generation interconnection study, if available, were used.

If dynamic models were not available, then generic models were used. For geothermal, biomass, biogas and solar thermal projects, the dynamic models of similar existing units in the system were used, which included generator, exciter, power system stabilizer and governor models. For wind turbine and PV solar generators, generic GE Positive Sequence Load Flow Software models were used. In this study, a Type 3 wind turbine generator model for doubly fed induction generators was used for wind generators. A Type 4 inverter model used for a machine with full converter interface and variable speed was used for PV solar generators. For both Type 3 and Type 4 dynamic models, the control parameters were set such that the generators have adequate low voltage ride through and low frequency ride through capability.

#### **4.1.4.2 Generation Dispatch and Path Flow in Base Cases**

Production cost simulation software was used to predict unit commitment and economic dispatch on an hourly basis for the study year with the results used as reference data to predict future dispatch and flow patterns.

Certain hours that represent stressed patterns of path flows in the 2023 study year were selected from the production cost simulation results with the objective of studying a reasonable upper bound on stressed system conditions. The following three critical factors were considered in selecting the stressed patterns:

- renewable generation output system wide and within renewable study areas;
- power flow on the major transfer paths in California; and
- load level.

For example, hours that were selected for reference purposes were time frames during which there were near maximum renewable generation output within key study areas (Tehachapi, Riverside, Imperial, Fresno, etc.) and near maximum transfers across major ISO transmission paths during peak hours or off-peak hours.

It was recognized that modeling network constraints had significant impacts on the production cost simulation results. The simplest constraints are the thermal branch ratings under normal and contingency conditions. It was not practical to model all contingencies and branches in the simulation because of computational limitations. Given this gap between the production cost simulation and the power flow and stability assessments, as well as the fact that the production cost simulation is based on the DC power flow model, the dispatch of conventional thermal units in power flow and stability assessments generally followed variable cost to determine the order of dispatch, but out of order dispatch may have been used to mitigate local constraints.

#### **4.1.5 Testing Deliverability for RPS**

To supplement the limited number of generation dispatch scenarios that can be practically studied using traditional power flow modeling techniques, and to verify the deliverability of the renewable resources modeled in the base portfolio, an assessment was performed based on the ISO deliverability study methodology.

The objectives of the deliverability assessment are as follows:

- model the target expanded maximum import capability (MIC) for each intertie to support deliverability for the MW amount of resources within each intertie in the base portfolio;
- test the deliverability of the new renewable resources in the base portfolio located within the ISO balancing authority; and
- identify network upgrades needed to support full deliverability of the new renewable resources and renewable resources in the portfolio utilizing the expanded MIC.

#### 4.1.5.1 Deliverability Assessment Methodology

The assessment was performed following the on-peak [Deliverability Assessment Methodology](#). The main deliverability assessment steps are described below.

#### 4.1.5.2 Deliverability Assessment Assumptions and Base Case

A master base case was developed for the on-peak deliverability assessment that modeled all the generating resources in the base portfolio. Key assumptions of the deliverability assessment are described below.

##### Transmission

The same transmission system as in the base portfolio power flow peak case was modeled.

##### Load modeling

A coincident 1-in-5 year heat wave for the ISO balancing authority area load was modeled in the base case. Non-pump load was the 1-in-5 peak load level. Pump load was dispatched within expected range for summer peak load hours.

##### Generation capacity (Pmax) in the base case

The most recent summer peak NQC was used as Pmax for existing thermal generating units. For new thermal generating units, Pmax was the installed capacity. Wind and solar generation Pmax data were set to 20 percent or 50 percent exceedance production level during summer peak load hours. If the study identified 20 or more non-wind generation units contributing to a deliverability constraint, both wind and solar generations were assessed for maximum output of 50 percent exceedance production level for the deliverability constraint, otherwise up to a 20 percent exceedance production level was assessed.

Table 4.1-5: Wind and solar generation exceedance production levels (percentage of installed capacity) in deliverability assessment

Type	20% Exceedance		50% Exceedance	
	Northern California	Southern California	Northern California	Southern California
Wind	51%	64%	28%	40%
Solar	100%	100%	85%	85%

##### Initial Generation Dispatch

All the existing generators were dispatched at 80 percent to 92 percent of the capacity. The new generators were dispatched up to 80 percent of the capacity to balance load and maintain expected imports.

Import Levels

Imports are modeled at the maximum summer peak simultaneous historical level by branch group. The historically unused existing transmission contracts (ETCs) crossing control area boundaries were modeled as zero MW injections at the tie point, but available to be turned on at remaining contract amounts. For any intertie that requires expanded MIC, the import is the target expanded MIC value. Table 4.1-6 shows the import megawatt amount modeled on the given branch groups.

Table 4.1-6: Deliverability assessment import target

Branch Group Name	Direction	Net Import MW	Import Unused ETC & TOR MW
Lugo-Victorville-BG	N-S	1,432	141
COI_BG	N-S	3,770	548
BLYTHE_BG	E-W	45	0
CASCADE_BG	N-S	36	0
CFE_BG	S-N	-119	0
ELDORADO_MSL	E-W	1,213	0
IID-SCE_BG	E-W	1,500	0
IID-SDGE_BG	E-W		0
LAUGHLIN_BG	E-W	-38	0
MCCULLGH_MSL	E-W	7	316
MEAD_MSL	E-W	938	455
NGILABK4_BG	E-W	-131	168
NOB_BG	N-S	1,208	0
PALOVRDE_MSL	E-W	2,872	168
PARKER_BG	E-W	126	28
SILVERPK_BG	E-W	0	0
SUMMIT_BG	E-W	6	0
SYLMAR-AC_MSL	E-W	-164	368
Total		12,599	2,192

#### **4.1.5.3 Screening for Potential Deliverability Problems Using DC Power Flow Tool**

A DC transfer capability and contingency analysis tool was used to identify potential deliverability problems. For each analyzed facility, an electrical circle was drawn consisting of all generating units, including unused existing transmission contract injections that fall within 5 percent or more of the distribution factor (DFAX) region. These are expressed as follows:

- Distribution factor = (change in flow on the analyzed facility / change in output of the generating unit) \*100 percent
- or
- Flow impact = (DFAX \* capacity / applicable rating of the analyzed facility) \*100 percent; where NQC represents the net qualifying capacity of a generating unit.

Load flow simulations were performed, which studied the worst-case combination of generator output within each 5 percent circle.

#### **4.1.5.4 Verifying and refining the analysis using AC power flow tool**

The outputs of capacity units in the 5 percent circle were increased starting with units with the largest impact on the transmission facility. No more than 20 units were increased to their maximum output. In addition, generation increases were limited to 1,500 MW or less. All remaining generation within the ISO balancing authority area was proportionally displaced to maintain a load and resource balance.

When the 20 units with the highest impact on the facility can be increased by more than 1,500 MW, the impact of the remaining amount of generation to be increased was considered using a Facility Loading Adder. This adder was calculated by taking the remaining MW amount available from the 20 units with the highest impact multiplied by the DFAX for each unit. An equivalent MW amount of generation with negative DFAXs was also included in the adder, up to 20 units. If the net impact from the contributions to adder was negative, the impact was set to zero and the flow on the analyzed facility without applying the adder was reported.

## 4.2 Policy-Driven Assessment in Northern CA (PG&E Area)

The renewable generation scenarios assessment included the three renewable portfolios evaluations described earlier: Commercial Interest, Environmentally Constrained and High DG. Power flow studies were performed for all credible contingencies in the same areas of the PG&E transmission system as in the reliability studies. Category C3 contingencies, which is an outage of one transmission facility after another non-common-mode facility is already out, were not studied because it was assumed that the negative impacts can be mitigated by limiting generation following the first contingency. The assessment results were summarized for Northern California without detailed descriptions of each zone. Post transient and transient stability studies that evaluated all major 500 kV single and double contingencies and two-unit outages of nuclear generators were performed for the Northern bulk system. The area studies and the bulk system studies included all three portfolios for 2023 peak and off-peak conditions. The area planning divisions in the PG&E area are shown in the figure below.

Figure 4.2-1: Planning area divisions of the PG&E system

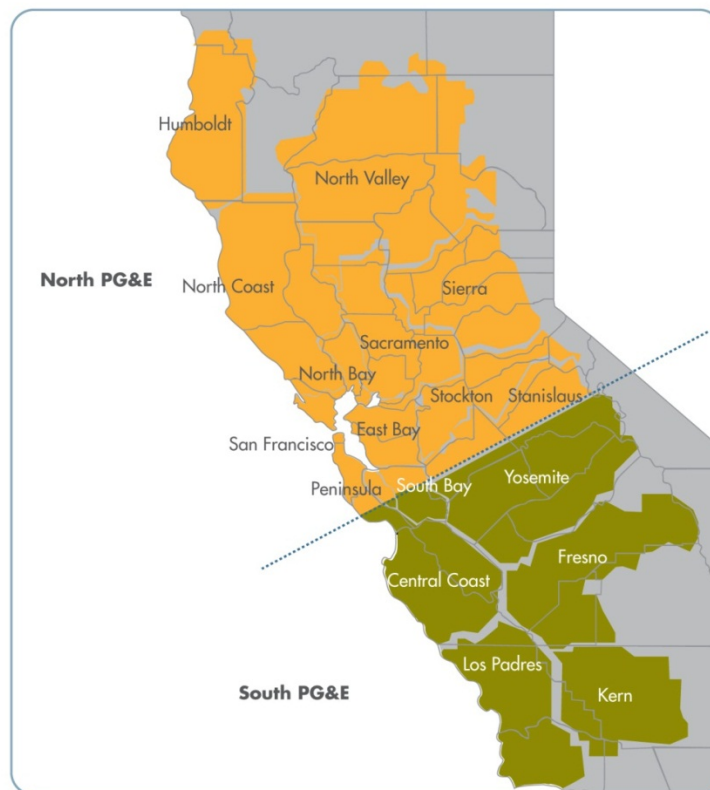



#### 4.2.1 PG&E Policy-Driven Powerflow and Stability Assessment Results and Mitigations

The PG&E area studies included assumptions on the renewable resources summarized in Table 4.2-1 and Table 4.2-2 shows how these resources were distributed among the CREZs.

Table 4.2-1: Renewable resources in PG&E area modeled to meet the 33 percent RPS net short

<b>Portfolio</b>	<b>Renewable Capacity, MW</b>
Commercial Interest	2,762
Environmentally Constrained	4,171
High DG	4,057

Table 4.2-2: PG&E Area Renewable Generation by zones modeled to meet 33 percent RPS net short

<b>Zones</b>	<b>Commercial Interest</b>	<b>Environmentally Constrained</b>	<b>High DG</b>
Carrizo South	900	900	300
Central Valley North	25	173	25
Los Banos	370	0	0
Merced	62	62	62
NonCREZ	73	222	73
Solano	200	0	0
Westlands	148	1285	148
Distributed Generation - PG&E	984	1,529	3,449
<b>Total</b>	<b>2,762</b>	<b>4,171</b>	<b>4,057</b>

PG&E areas include the following divisions: Humboldt, North Coast, North Bay, San Francisco, Peninsula, South Bay, East Bay, North Valley, Sacramento, Sierra, Stockton and Stanislaus, Yosemite, Fresno, Kern, Central Coast and Los Padres areas. These areas were described in detail in chapter 2, so, the following sections include only the study results and mitigations.

#### **4.2.1.1 PG&E Bulk System**

The PG&E area bulk system assessment for the three renewable generation portfolios was performed with the same methodology that was used for the reliability studies described in chapter 2. All single and common mode 500 kV system outages were studied, as were outages of large generators and contingencies involving stuck circuit breakers and delayed clearing of single-phase-to ground faults for all three portfolios. The studies also included extreme events such as a northeast/southeast separation, outage of all three lines of Path 26 and outages of major substations, such as Los Banos, Tesla and Midway (500 and 230 kV busses). The following three generation portfolios were studied under the 2023 peak and off-peak load conditions: Commercial Interest, Environmentally Constrained and High Distributed Generation portfolios.

For the peak load conditions, it was assumed that the Helms Pump Storage Power Plant was operating in the generation mode with three units generating. For the off-peak system conditions, the studies were performed with an assumption that the facility operated in the pumping mode with two units pumping in all portfolios.

Post transient and transient stability studies were conducted for all the cases and scenarios.

Transient stability studies for the peak and off-peak load conditions did not identify any additional criteria violations or un-damped oscillations compared with the reliability studies. On the contrary, transient voltage dip at the irrigational pumps connected to the Midway 230 kV substation with three-phase faults at the Midway 230 kV bus was not as large as in the reliability studies, and the oscillations were not as large. The better system performance can be explained by the dynamic reactive support from the new generation projects located in the Midway area. However, the new projects were not sufficient to mitigate all the concerns. As in the reliability studies, some pumping load at Midway may be lost with a three-phase fault at the Midway 230 kV bus.

For the post-transient (governor power flow) studies, only transmission facilities 115 kV and higher were monitored because lower voltage facilities were studied with other outages in the detailed assessments of the PG&E areas that are described in these area studies.

The study results are discussed below with only those facilities that are negatively impacted by additional renewable generation being included. The overloaded facilities described below are listed in the order from the north to south of the PG&E system.

#### **4.2.1.1.1 Study Results and Discussion**

##### **Thermal Overloads**

###### Table Mountain 500/230 kV transformer

This transformer bank was identified as overloaded by 4 percent over its normal rating under Category C contingency conditions with a double outage of two 500 kV transmission lines south of Table Mountain: Table Mountain-Tesla and Table Mountain-Vaca Dixon during Summer Peak in the Commercial Interest portfolio case. No overload of the Table Mountain 500/230 kV transformer was observed in other portfolios. The loading of this transformer with the same contingency and same RAS in the reliability studies was 100 percent of its normal rating.

This transformer doesn't have an emergency rating. The same as in the reliability studies, possibility of overload was identified in the sensitivity studies that assumed that the existing CDWR RAS, which includes tripping of generation at the Hyatt and Thermalito hydro power plants, was applied.

Loading on the Table Mountain transformer with the South of Table Mountain 500 kV double line outage depends significantly on the RAS applied with this outage and which generation units it trips. The existing RAS trips generation in the Northwest (up to 2,400 MW depending on the COI flow) and from the Feather River, as well as irrigational pump load in Northern and Southern California. CDWR RAS that trips the pumps and the Hyatt and Thermalito generation, which is on the Feather River, will expire at the end of 2014.

Without the CDWR RAS, the Table Mountain 500/230 kV transformer is not expected to overload.

###### Los Banos-Switching Station Section of the Westley-Los Banos 230 kV Transmission Line

This transmission line section may overload under off-peak load conditions. In the Environmental portfolio, the overload was identified under normal system conditions as well as with Category B and C contingencies. In all other portfolios, the overload was observed with a Category C contingency of the 500 kV double line outage (DLO) North of Los Banos (Los Banos-Tracy and Los Banos-Tesla 500 kV lines). The reliability studies did not identify overload on the Los Banos-Switching Station 230 kV line section in an assumption that all appropriate RAS are applied with the North of Los Banos DLO.

The section of the Westley-Los Banos 230 kV line between the Switching Station and the Westley Substation is planned for upgrading when the renewable generation project connected to the Westley-Los Banos 230 kV line comes on line. This upgrade was modeled in the base cases.

The Los Banos-Switching Station line section normal overload in the Environmental portfolio is explained by high south-to-north flow on the Westley-Los Banos 230 kV line. This flow is caused in part by three large solar PV projects modeled in this portfolio: a project connected to the Panoche-McMullin and Panoche-Helm 230 kV lines, a project connected to the 115 kV Shindler Substation, and a project connected to the Mendota-Newhall 115 kV transmission line. These three projects were not modeled in other RPS portfolios. Emergency overload on the Los Banos-Switching Station 230 kV line section with the North of Los Banos DLO in the

Environmental and other portfolios is explained by high south-to-north flow on Path 26 and Path 15 because of high renewable generation dispatch in Southern California and also that the renewable project connected to the Los Banos-Westley 230 kV line was not dispatched in the renewable portfolios. This project's output would reduce flow on the southern section of the Westley-Los Banos line. Figure 4.2–2 illustrates the area and the overload.

Figure 4.2–2 Overloads on the Los Banos-Westley 230 kV Line

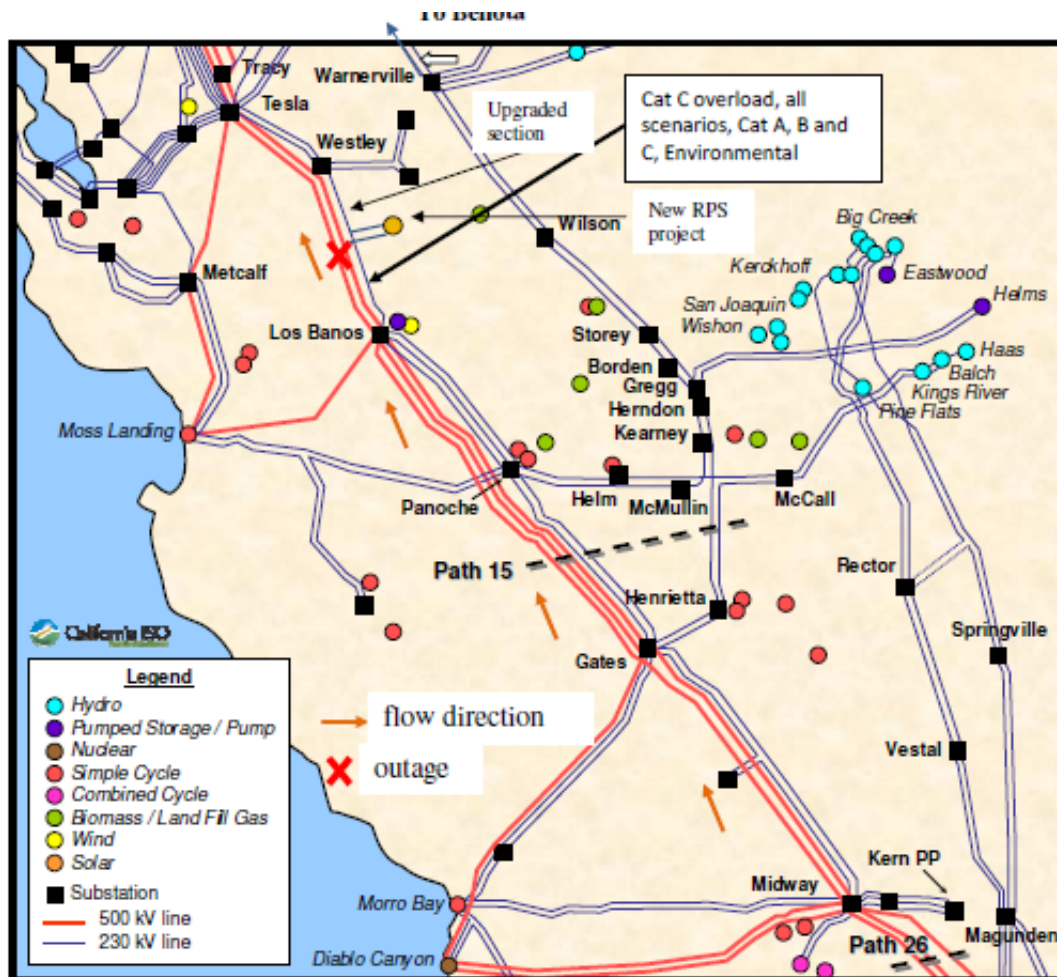

Since the overload on the Los Banos-Switching Station 230 kV transmission line section is expected only under off-peak load conditions and caused by over-generation, congestion management to reduce generation under the off-peak conditions will mitigate the overload. Another solution may be an upgrade of this line section if large amount of renewable generation projects develops in the area.

#### Exchequer-Le Grand 115 kV Transmission Line

Overload on this transmission line was identified under off-peak normal system conditions with all facilities in service in the Commercial Interest and High DG portfolio. This overload is explained by over-generation due in part to the new renewable generation projects connected to the 70 kV system from the Exchequer Substation in addition to high output of the Exchequer

hydro plant. This is a local issue that will need to be resolved in the GIP process if these renewable projects develop. The location of the Exchequer-Le Grand transmission line is shown in Figure 4.2.1.1–2.

115 kV Transmission Line Overloads in the Fresno Area

Several 115 kV transmission lines were identified as overloaded under normal and Category B and C contingency conditions under the off-peak load conditions in the Environmental portfolio. These overloads are caused by over-generation because of the renewable projects modeled in the Fresno area in this portfolio.

The Category A (normal conditions) overloads are summarized in Table 4.2–3. Some of these facilities were also overloaded under contingency conditions. Only overloads with the bulk system contingencies (500 kV outages) are shown. More details about the overloads and their mitigations are provided in the Fresno area studies.

Table 4.2–3. Category A Overloads in the Fresno Area in the Environmental Portfolio under off-peak load conditions

Overloaded Facility	Normal Loading	Emergency Loading	Cause for the overload
Kingsburg- Waukena Sw Sta (Corcoran) 115 kV # 2	144%	Cat C 123%	projects at Corcoran 115 kV and 70 kV buses
Kingsburg-Corcoran 115 kV # 1	136%	Cat C 117%	
Panoche-Shindler # 1 115 kV (Kamm-Cantua section)	109%	Cat B 99%, Cat C 105%	project at Cantua 115 kV or project at Shindler 115 KV
Panoche-Shindler # 1 115 kV (Panoche-Kamm section)	107%	Cat B 97%, Cat C 103%	
Panoche-Shindler # 2 115 kV (Cheney tap-Panoche section)	106%	Cat B 97%, Cat C 103%	Project at Shindler 115 kV
Panoche-Shindler # 2 115 kV (Cheney tap-Shindler section)	102%	Cat C 99%	
Shindler-Westlands 115 kV	101%	Cat C 98%	
Cantua-Westlands 115 kV	100%	Cat C 97%	

Because the observed overloads were directly related to the renewable generation projects modeled in the case, mitigation of the overloads will need to be resolved in the GIP process if these renewable projects develop. Overloaded 115 kV transmission lines in the off-peak Environmental portfolio are illustrated in Figure 4.2–3.

Figure 4.2–3. Off-peak Overloads in the Fresno Area under Normal Conditions

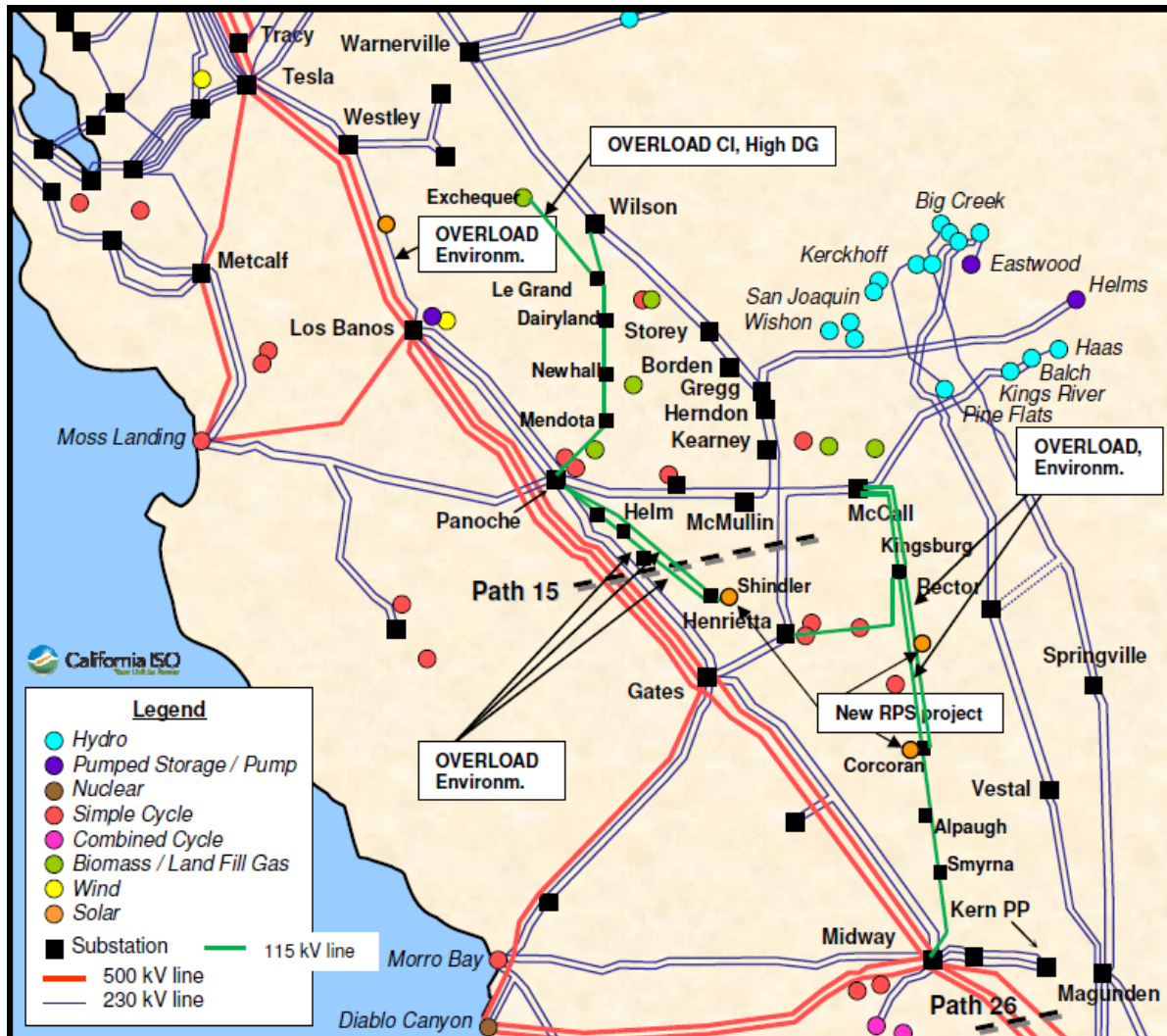

**Voltage Issues**

*Voltage and Voltage Deviation Concerns*

No voltage or voltage deviation concerns were identified on the PG&E bulk system in the studies in any renewable portfolios both under peak and off peak load conditions.

**Transient Stability Concerns**

Compared with the results of the reliability studies described in chapter 2, no additional concerns were identified in the transient stability studies in any of the renewable portfolios both under peak and off-peak load conditions.

### 4.2.1.2 Humboldt Area

The Humboldt area is located in the most northern part of the PG&E system along the Pacific Coast. The studies for renewable portfolios assumed 0 MW of renewable generation in Humboldt in the base case and the Environmentally Constrained portfolios. The High DG scenario had 42 MW of renewables modeled in the Humboldt area.

#### 4.2.1.2.1 Study Results and Discussion

##### Thermal Overloads

##### Rio Dell Junction-Bridgeville 60 kV transmission line

The Carlotta to Rio Dell section of the Rio Dell Junction-Bridgeville 60 kV transmission line may overload under Category B contingency of the loss of the Humboldt-Bridgeville 115 kV line in the peak load Environmental portfolio case. Under this scenario the line is seen to be loaded to 101.6 percent of its emergency rating. The line was also seen to be heavily loaded to 94.7 percent of its emergency rating for the same contingency in the peak load High DG portfolio. The loading on this line is primarily been driven by the high levels of generation dispatch in the Humboldt Bay power plant at 60 kV in the starting base case. The overload can be mitigated by reducing the Humboldt Bay 60 kV generation. The observed thermal overload problems and their solutions are illustrated in Figure 4.2-4.

Figure 4.2-4: Humboldt area overloads

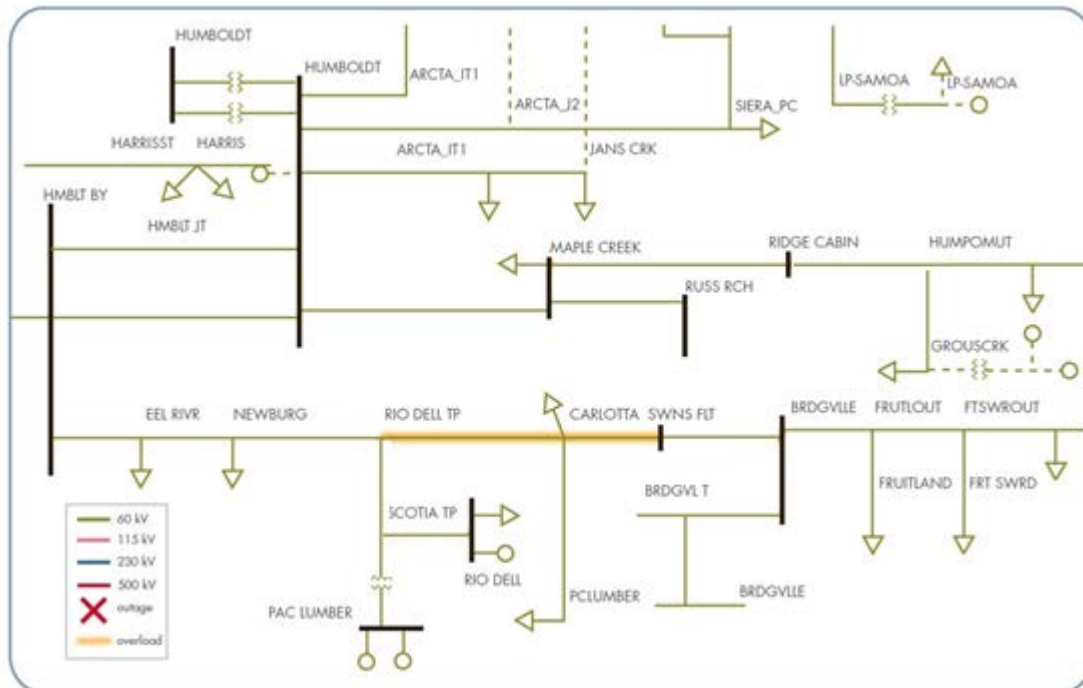

## **Voltage Issues**

### ***Voltage and Voltage Deviation Concerns***

No voltage concerns were identified in the Humboldt area for any of the renewable portfolios under peak or off-peak load conditions.

#### **4.2.1.3 North Coast and North Bay Area**

The North Coast and North Bay areas are located between the Humboldt area and San Francisco and include Mendocino, Lake, Sonoma and Marin counties and parts of Napa and Solano counties.

The RPS studies have modeled two new renewable generators in the North Coast / North Bay area. A 63 MW biomass unit interconnecting into the Mendocino 60 kV bus was modeled in the Environmentally Constrained cases. This generator was not modeled in the base portfolio or the High DG portfolio. A 32 MW geothermal unit interconnecting into the Geysers #3 – Cloverdale 115 kV line was modeled in all the three portfolios.

The base portfolio has 32 MW of renewable generation attributable to a new 32 MW geothermal unit. There was no DG modeled in the base portfolio in the North Coast – North Bay area. The Environmental portfolio has a total of 139 MW of renewable generation modeled out of which 44 MW is DG and the rest coming from the two large renewable generation projects discussed above. The High DG portfolio has a total of 371 MW of renewable generation modeled in the North Coast – North Bay area. This portfolio has a total of 339 MW of DG modeled along with the 32 MW geothermal unit discussed above.

##### **4.2.1.3.1 Study Results and Discussion**

The scope of this analysis is limited to reporting the transmission issues resulting exclusively because of the renewable portfolio. Results of the North Coast and North Bay reliability analysis have already been presented in chapter 2. The study provided details of the facilities in the North Coast and North Bay areas that were identified as not meeting thermal loading and voltage performance requirements under normal and various system contingency conditions. This analysis with the renewable portfolio modeled found only one constraint that was not identified in the reliability assessment. Additionally, it was also seen that the mitigations that were identified in the reliability assessment would effectively solve the thermal and voltage constraints that were seen in the renewable portfolio analysis.

## **Thermal Overloads**

### **Hopland Jct 115/60kV Transformer**

The 115/60 kV transformer at Hopland Jct station was found to be overloaded to 108.3 percent of its normal rating in the 2023 off-peak case in the Environmental portfolio under the Category C contingency of a bus fault at Eagle Rock 115 kV station. The transformer is also seen to be heavily loaded to 99.3 percent of its rating in the 2023 Peak Load cases in the Environmental portfolio. It was also found that the overload is a localized concern that is being driven by a single renewable generator that was modeled in the cases. This overload will be addressed in



the generator interconnection studies of the renewable generator and an appropriate mitigation will be developed in the interconnection study process.

No other thermal issues incremental to what have already been identified in the reliability were seen in this analysis.

## **Voltage Issues**

### ***Voltage and Voltage Deviation Concerns***

No voltage or voltage deviation issues in addition to what have already been identified in the reliability analysis discussed in chapter 2 were identified in this analysis. Voltage violation issues that are local in nature may arise depending on where the renewable generators will actually connect to the grid. Such issues can be sufficiently mitigated by requiring all renewable generators, including distributed generation, to provide 0.95 lead/lag power factor capability and by adjusting transformer taps on the 115/60 kV transformers in the area.

#### **4.2.1.4 North Valley Area**

This area includes the Northern end of the Sacramento Valley and parts of the Siskiyou and Sierra mountain ranges and foothills. The reliability studies described in chapter 2 modeled the new 103 MW Hatchet Ridge wind plant connected to the Round Mountain-Pit River #3 230 kV transmission line. In addition to the Hatchet Ridge plant, the renewable portfolio studies included 65 MW of new renewable resources in non-CREZ zone in the Environmentally Constrained portfolio. Also, 288 MW of renewable resources were modeled in the high DG portfolio in North Valley area.

##### **4.2.1.4.1 Study Results and Discussion**

Following is a summary of the study results of facilities in the North Valley area that were identified as not meeting thermal loading and voltage performance requirements under normal and various system contingency conditions. The discussion includes proposed mitigation plans for these reliability concerns. Only facilities that are negatively impacted by additional renewable generation are included.

### **Thermal Overloads**

#### **Delevan-Cortina 230 kV Line**

The Delevan-Cortina 230 kV line is expected to overload under Category C contingency condition in the Commercial Interest portfolio in summer peak. Rerating the line to a higher rating will mitigate this overload issue. If it is not feasible to rerate the line, the line will need to be reconducted. The ISO will continue to work with PG&E on the feasibility of rerating the line.

#### **Trinity-Keswick & Keswick-Cascade 60 kV Line**

The Trinity-Keswick and Keswick-Cascade 60 kV lines are expected to overload under categories B and C contingency conditions in the Environmentally Constrained portfolio in summer peak and under Category C conditions in off-peak. This is a localized issue caused by specific resource and will be addressed in the generator interconnection process.

Cottonwood-Panorama 115 kV Transmission Line

The Cottonwood-Panorama 115 kV transmission line is a radial line from the Cottonwood Substation. Overload on the Wheelabrator-Cottonwood section was observed in the Commercial Interest and High DG portfolios under off-peak load conditions with all facilities in service (Category A). This overload is caused by over-generation due to the new renewable project modeled at the Panorama 115 kV substation. This is a localized issue caused by specific resource and will be addressed in the generator interconnection process.

Figure 4.2–5: Overload concerns in the North Valley area

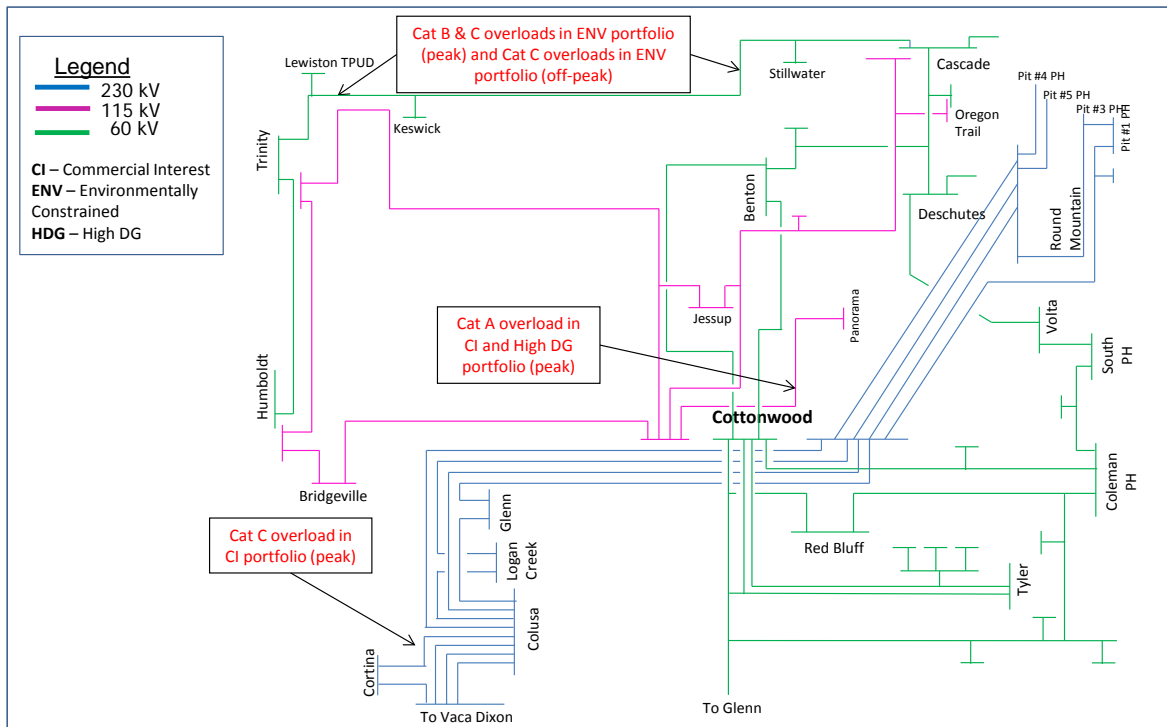

**Voltage Issues**

No additional voltage issues were identified on top of what has been identified in the reliability assessment.

#### **4.2.1.5 Central Valley Area**

The Central Valley area includes the central part of the Sacramento Valley, and it is composed of the Sacramento, Sierra, Stockton and Stanislaus divisions. The reliability studies described in chapter 2 modeled several existing and new renewable projects. This included the Wadham and Woodland biomass projects in Sacramento; the wind generation projects Enxco, Solano, Shiloh and High Winds in Solano County; and existing small hydro projects in the Sierra and Stanislaus divisions. In the renewable portfolios, additional renewable generation was modeled in the Central Valley area. In the base portfolio, 25 MW of renewable resources were modeled in the Central Valley area. In the Environmentally Constrained portfolio, 216 MW of new renewable resources were modeled in Central Valley area. In the High DG portfolio, 829 MW of new renewable resources were modeled in the Central Valley area.

##### **4.2.1.5.1 Study Results and Discussion**

The following summarizes the study results of facilities in the Central Valley area that were identified as not meeting thermal loading and voltage performance requirements under normal and various system contingencies. The discussion includes proposed mitigation plans for these reliability concerns. Only facilities that are negatively impacted by additional renewable generation are included.

##### **Thermal Overloads**

Under peak load conditions, no additional thermal overloads or voltage concerns were identified in the Central Valley area in any of the three portfolios.

##### *Tesla-Salado-Manteca and Tesla-Salado #1 115 kV*

The Tesla-Salado-Manteca and Tesla-Salado #1 115 kV lines are expected to overload under Category B contingency conditions in the Environmentally Constrained portfolio in off-peak conditions. This is a localized issue caused by specific resource and will be addressed in the generation interconnection process generator interconnection process.

Figure 4.2–6: Overload concerns in the Central Valley area

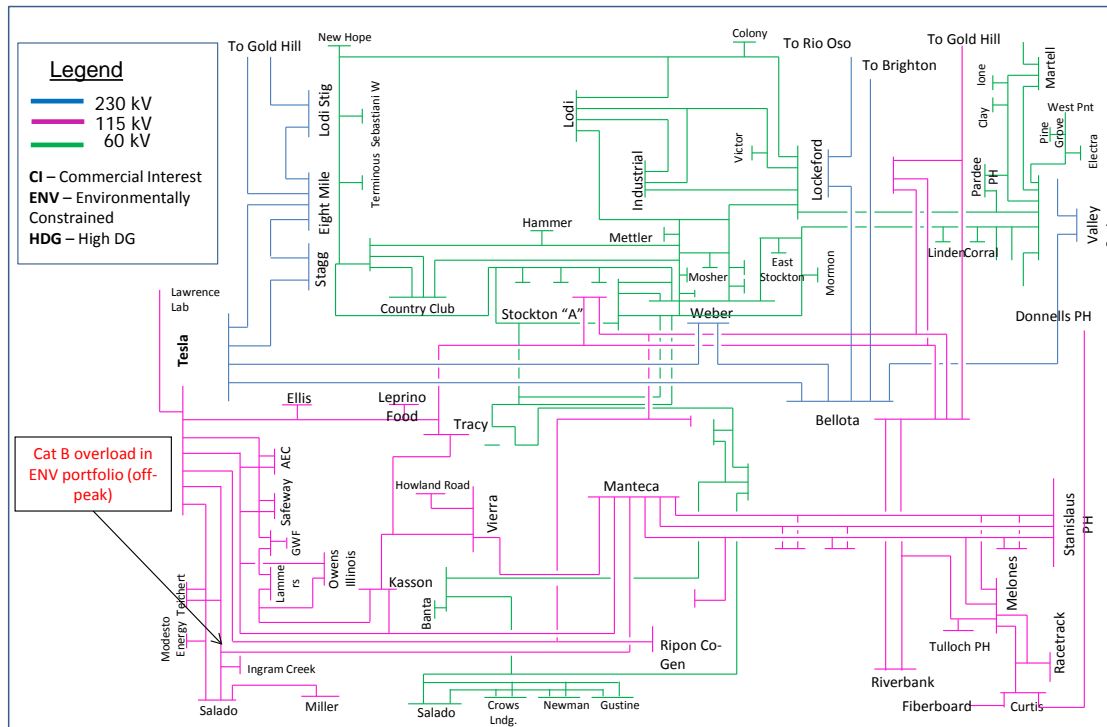

**Voltage Issues**

***Voltage and Voltage Deviation Concerns***

No additional voltage issues were identified on top of what has been identified in the reliability assessment.

**4.2.1.6 Greater Bay Area**

This area includes Alameda, Contra Costa, Santa Clara, San Mateo and San Francisco counties. For the transmission performance evaluation, it is divided into three sub-areas: East Bay, South Bay and San Francisco-Peninsula. Renewable portfolio studies included additional renewable generation capacity in the Bay area.

The High DG portfolio had 290 MW of new renewable generation in the Alameda County, 89 MW in the San Mateo County, 171 MW of new renewable generation in the Santa Clara County, 177 MW of new renewable generation in the Contra Costa County, and 11 MW of new renewable generation in San Francisco-Peninsula.

The Environmentally Constrained portfolio had 152 MW of new renewable generation in the Alameda County, 65 MW in the San Mateo County, 150 MW of new renewable generation in the Santa Clara County, 63 MW of new renewable generation in the Contra Costa County, and 11 MW of new renewable generation in San Francisco-Peninsula.

The Commercial Interest portfolio had 0 MW of new renewable generation in the Alameda County, 1 MW in the San Mateo County, 144 MW of new renewable generation in the Santa Clara County, 0 MW of new renewable generation in the Contra Costa County, and no new renewable generation in San Francisco Peninsula.

The majority of the renewable projects modeled in the Bay area were small distributed photovoltaic generators.

Table 4.2–4: Summary of renewable generation capacity in PGE Greater Bay Area

Area by County	Renewable Generation Capacity by portfolio (MW)		
	Commercial Interest	Environmentally Constrained	High DG
Alameda	0	152	290
Contra Costa	0	63	177
Santa Clara	144	150	171
San Francisco	0	11	11
San Mateo	1	65	89
<b>Total</b>	<b>145</b>	<b>441</b>	<b>738</b>

#### 4.2.1.6.1 Study Results and Discussion

The following summarizes the study results of facilities in the Greater Bay Area that were identified as not meeting thermal loading and voltage performance requirements under normal and various system contingencies. The discussion includes proposed mitigation plans for these reliability concerns. Only facilities that are negatively impacted by additional renewable generation are included.

##### Thermal Overloads

Under peak load conditions, two transmission lines in the San Jose area were identified as overloaded.

##### Metcalf-Morgan Hill 115 kV transmission line

Metcalf-Morgan Hill 115 kV transmission line may overload with a Category C1 contingency in the Commercial Interest and Environmentally Constrained portfolios. The most critical Category C contingency is an outage at BUS FAULT AT 35648 LLAGAS 115 kV Bus. This is a localized issue caused by a specific resource and will be addressed in the generator interconnection process.

Metcalfe-Llagas 115 kV transmission line

Metcalfe-Llagas 115 kV transmission line may overload with Category C1 contingency in the Commercial Interest, Environmentally Constrained and High DG portfolios. The most critical Category C contingency is a 115 kV bus fault at Llagas substation. This is a localized issue caused by a specific resource and will be addressed in the generator interconnection process.

Under non-peak load conditions, no overload was identified.

**Voltage Issues*****Voltage and Voltage Deviation Concerns***

Under peak load conditions, low voltages and voltage deviation were observed in the San Jose 60 kV system in all portfolios. To alleviate the voltage concerns under peak load conditions, mitigation would require 0.95 lead/lag power factor capability for distributed generation in the San Jose areas. Another alternative is to be addressed in GIP.

Under off-peak load conditions, no low voltages and voltage deviation were observed in all portfolios.

**4.2.1.7 Fresno and Kern Area**

The Fresno and Kern areas are located between the Greater San Francisco Bay Area, Central Coast/Los Padres and Southern California and include Merced, Mariposa, Madera, Fresno, Kings, Tulare, and Kern counties. The Base portfolio has 686 MW of renewable generation, the Environmental portfolio has 865 MW and High DG portfolio has 1046 MW.

**4.2.1.7.1 Study Results and Discussion**

The following summarizes the study results of facilities in the Fresno and Kern area that were identified as not meeting thermal loading and voltage performance requirements under normal and various system contingencies. The discussion includes proposed mitigation plans for these reliability concerns. The reporting has been limited to the new problems or any incremental problems identified in the reliability analysis.

**Thermal Overloads**Coalinga 1-Coalinga 2 70 kV (Coalinga 1-Tornado Tap Section)

This line section was found to be overloaded under all categories in the Environmental portfolio under off-peak conditions. This is a local concern that should be addressed during the generator interconnection process.

Corcoran #1 115/70 kV

This transformer was found to be overloaded under Category A in the Environmental portfolio off-peak conditions. This is a local concern that should be addressed during the generator interconnection process.

Corcoran-Anqiola 70 kV (Boswell Tap-Boswell Tomato Plant Section)

This section of the line was found to be overloaded under Category A in the Environmental portfolio off-peak conditions. This is a local concern that should be addressed during the generator interconnection process.

Exchequer-Le Grand 115 kV

This line was found to be overloaded under Category A, B and C1 contingencies in the High DG portfolio under off-peak conditions. This is a local concern that should be addressed during the generator interconnection process.

Gates #5 230/70 kV

This overload was observed in the off-peak Environmental portfolio for C2 and C5 contingencies. This is a local concern that should be addressed during the generator interconnection process.

Gates-Huron 70 kV

This overload was observed in the off-peak Environmental portfolio for C2 and C5 contingencies. This is a local concern that should be addressed during the generator interconnection process.

Kingsburg-Corcoran #1 115 kV

This overload was observed in the off-peak Environmental portfolio for Category A, B, C1 and C5 contingencies. This is a local concern that should be addressed during the generator interconnection process.

Kingsburg-Waukena Switching Station 115 kV

This overload was observed in the off-peak Environmental portfolio for Category A and B contingencies. This is a local concern that should be addressed during the generator interconnection process.

Waukena Switching Station-Corcoran 115 kV

This overload was observed in the off-peak Environmental portfolio for Category B contingencies. This is a local concern that should be addressed during the generator interconnection process.

McCall-Kingsburg #1 115 kV (Kingsburg Jct 1-Kingsburg Jct 2 Section)

This overload was observed in the off-peak Environmental portfolio for Category B contingencies. This is a local concern that should be addressed during the generator interconnection process.

McCall-Kingsburg #2 115 kV (Guardian Jct-Kingsburg Section)

This overload was observed in the off-peak Environmental portfolio for Category C1 contingencies. This is a local concern that should be addressed during the generator interconnection process.

*Panoche-Schindler #1 115 kV (Kamm-Cantua Section)*

This overload was observed in the off-peak Environmental portfolio for Category A, B, C1, C2 and C5 contingencies. This is a local concern that should be addressed during the generator interconnection process.

*Panoche-Schindler #2 115 kV (Panoche-Cheney Tap Section)*

This overload was observed in the off-peak Environmental portfolio for Category A, B, C1, C2 and C5 contingencies. This is a local concern that should be addressed during the generator interconnection process.

*Schindler #1 115/70 kV*

This overload was observed in the off-peak Environmental portfolio for Category C2 and C5 contingencies. This is a local concern that should be addressed during the generator interconnection process.

*Schindler-Coalinga #2 70 kV (Schindler-Pleasant Valley Section)*

This overload was observed in the off-peak Environmental portfolio for Category C2 and C5 contingencies. This is a local concern that should be addressed during the generator interconnection process.

*Schindler-Huron-Gates 70kV (Huron Jct-Calflax Section)*

This overload was observed in the off-peak Environmental portfolio for Category C1, C2 and C5 contingencies. This is a local concern that should be addressed during the generator interconnection process.

*Schindler-Huron-Gates 70 kV (Schindler-S532SS Section)*

This overload was observed in the off-peak Environmental portfolio for Category A conditions. This is a local concern that should be addressed during the generator interconnection process.

*2C577-Los Banos 230 kV*

This overload was observed in the off-peak Environmental portfolio for Category A conditions. This is an area concern that needs to be addressed.

*Panoche #1 230/115kV*

This overload was observed in the off-peak Environmental portfolio for Category B, C1 and C2 conditions. This is a local concern that should be addressed during the generator interconnection process.

**Voltage Issues****Off-Peak Voltage and Voltage Deviation Concerns**

No high or low voltage problems in the Fresno or Kern areas were identified as well as no off-peak voltage deviation problems.



## **On-Peak Voltage and Voltage Deviation Concerns**

No high or low voltage problems in the Fresno or Kern areas were observed. However, one voltage deviation in Fresno was noted as follows.

### **Kingsburg-Corcoran #2 115kV**

This voltage deviation was observed in the Commercial and High DG portfolios peak cases for a B contingency. This is a local concern that should be addressed during the generator interconnection process.

## **4.2.1.8 Central Coast and Los Padres Areas**

### **4.2.1.8.1 Study Results and Discussion**

The Central Coast area is located south of the Greater Bay Area and extends along the Central Coast from Santa Cruz to King City with the transmission system serving the Santa Cruz, Monterey and San Benito counties. The Los Padres area is located in the southwest portion of PG&E's service territory south of the Central Coast area with the transmission system serving the San Luis Obispo and Santa Barbara counties. The Base portfolio has 1,152 MW of renewable generation, the Environmental portfolio has 1,155 MW, and the High DG portfolio has 406 MW.

### **4.2.1.8.2 Study Results and Discussion**

The following is a discussion of the studies pertaining to facilities in the PG&E Central Coast and Los Padres areas. No additional thermal loading or voltage performance requirement concerns were noted during the policy studies.

## 4.2.2 Northern PG&E System Policy-Driven Deliverability Assessment Results and Mitigations

### Base Portfolio Deliverability Assessment Results

Deliverability assessment results for PG&E North area are shown in the table below.

Table 4.2–5: Base portfolio deliverability assessment results for PG&E North area

Overloaded Facility	Contingency	Flow	Undeliverable Zone	Mitigation
Cayetano-Lone Tree (USWP-Lone Tree) 230 kV line	Contra Costa-Moraga # one (1) & two(2) 230 kV lines	100%	Contra Costa Area	Continue to monitor in future cycles
Cayetano-Lone Tree (Cayetano-USWP-JRW) 230 kV line	Contra Costa-Moraga # one (1) & two(2) 230 kV lines	104%	Contra Costa Area	Continue to monitor in future cycles
Delevan-Cortina 230 kV Line	Delevan-Vaca Dixon #2 230 kV Line and Delevan-Vaca Dixon #3 230 kV Line	107%	Cottonwood Area	Rerate the line

Deliverability of the new renewable resources in the Solano CREZ is limited by overloads on the US Wind Power to Lone Tree 230 kV & Cayetano-US Wind Power sections of the Cayetano-Lone Tree 230 kV line and the Delevan-Cortina 230 kV lines. The ISO will continue to monitor this and generation development in the area in the future planning cycles. The overload mitigation on the Delevan-Cortina 230 kV line is to rerate the transmission line.

### Analysis of Other Portfolios

The need for transmission upgrades identified above is analyzed for other renewable portfolios by comparing the generation behind the deliverability constraint. The results are shown in Table 4.2–6. The generation capacity listed for each renewable zone represents only the generators contributing to the deliverability constraint and may be lower than the total capacity in the renewable zone.

Table 4.2–6: Portfolios requiring transmission upgrades

Transmission Upgrade	Renewable Zones	Com. Interest (MW)	High DG (MW)	Env. (MW)	Needed for portfolios
Cayetano-Lone Tree 230 kV line	Contra Costa Area (230 kV)	27	1.5	1.5	Commercial Interest High DG Env. Constrained
Delevan-Cortina 230 kV line	Cottonwood Area(115kV)	5.5	5.5	5.5	

### Recommendation

The following transmission upgrade is needed for the base portfolio, plus at least one other portfolio:

- re-rate or reconductor the Delevan-Cortina 230 kV line.

This transmission upgrade is recommended as policy-driven upgrade.

### Transmission Plan Deliverability with Recommended Transmission Upgrades

No area deliverability constraint was identified in PG&E North area.

### 4.2.3 Southern PG&E System Policy-Driven Deliverability Assessment Results and Mitigations

PGE south area consists of the following renewable zones: Carrizo south, Los Banos, Merced, Westland, Non CREZ Central Coast/ Los Padres & PGE distributed generation.

All the overloads seen in the deliverability analysis were also seen in the 2013-2014 Fresno reliability study. The mitigation proposed for the reliability analysis will ensure the deliverability of the PGE south portfolio generation as well.

Deliverability assessment results for PGE south area are shown in the table below.

Table 4.2–7: Deliverability assessment results for PG&E South Area

Overloaded Facility	Contingency	Flow	Undeliverable Zone	Mitigation
Chowchilla-Kerckhoff - From Chowchilla Sub To 2/16C (Chowchilla-CertanJ1)	Kerckhoff-E2 #1 & #2 115 kV Lines	156%	PG&E DG	Modify Kerckhoff 2 PH RAS
Chowchilla-Kerckhoff - From 2/16C To 34/9 (CertanJ1-Sharon Tap)	Kerckhoff-E2 #1 & #2 115 kV Lines	156%	PG&E DG	Modify Kerckhoff 2 PH RAS
Chowchilla-Kerckhoff – From 34/9 To 7/11 (Sharon Tap-Oakhurst Junction)	Kerckhoff-E2 #1 & #2 115 kV Lines	161%	PG&E DG	Modify Kerckhoff 2 PH RAS
Shepherd to Woodward 115 kV Line.	Gregg-E1 (New) #1 & #2 230 kV Line	118%	PG&E DG & Westlands	Modify Helms RAS, as part of North Fresno 115kV Area Reinforcement Project
Shepherd to E2 (New Sub) 115 kV Line.	Gregg-E1 (New) #1 & #2 230 kV Line	120%	PG&E DG & Westlands	Modify Helms RAS, as part of North Fresno 115kV Area Reinforcement Project

#### Recommendation

No transmission upgrades are recommended based on the policy-driven deliverability analysis for PGE south. All the overloads seen in the deliverability analysis were also seen in the 2013-2014 Fresno reliability study. The mitigation proposed for the reliability analysis will ensure the deliverability of the PGE south RPS generation.

#### 4.2.4 PG&E Area Policy-Driven Conclusions

The power flow studies for the PG&E North area showed that the existing transmission system is adequate to accommodate additional renewable generation assumed to be developed in the four portfolios. As discussed earlier in the report, the PG&E North study area includes Humboldt, North Coast, North Bay, North Valley, Central Valley and Greater Bay areas. Various thermal and voltage issues have been identified in the RPS study of these areas, which have also been seen in the reliability analysis as discussed in chapter 2 of this report. Mitigations developed in the reliability analysis have been used for common issues between the reliability analysis and RPS analysis, which became incrementally worse in the RPS study. Additional mitigations have been used only when the mitigation identified in the reliability analysis was found to not sufficiently mitigate the violation in the RPS study.

The policy-driven studies identified one PG&E bulk system facility that may overload under normal conditions. This facility, a section of the Westley-Los Banos 230 kV line was identified as overloaded under off-peak normal conditions in the Environmental portfolio. It may also overload in this portfolio under off-peak conditions following Category B and C contingencies. This overload was mainly caused by over generation because of the new renewable projects in the Fresno area modeled in this portfolio. Congestion management will mitigate this overload.

In addition, several 115 kV transmission lines in Fresno were overloaded under normal system conditions with all facilities in service in the Environmental portfolio during off-peak. These overloads were caused by over generation because of the new renewable projects connected in this area in the Environmental portfolio. These overloads are discussed in more detail in the Fresno area studies.

With an exception of the Westley-Los Banos 230 kV transmission line section overloaded in the Environmentally Constrained portfolio, no new Category B overloads were identified in the policy-driven assessment of the PG&E bulk transmission system beyond the overloads identified in the reliability studies.

One facility, Table Mountain 500/230 kV transformer, was identified as overloaded with a Category C contingency under peak load conditions in the Commercial Interest portfolio. This overload was observed in an assumption that the CDWR RAS that trips Hyatt and Thermalito generation under this contingency is still in place. The contract between CDWR and PG&E that includes the CDWR RAS is due to expire December 31, 2014. If the contract is not renewed and the RAS is not applied any longer, the Table Mountain 500/230 kV transformer is not expected to overload.

The off-peak studies identified an emergency overload on the Los Banos-Switching Station section of the Westley-Los Banos 230 kV line with a Category C contingency of a double line outage of the Los Banos-Tracy and Los Banos-Tesla 500 kV lines in all portfolios. In the Environmental portfolio, this line was also overloaded under normal conditions and with other contingencies, as described above. Mitigating this overload can be congestion management or the line upgrade if the renewable generation develops in the area.

The extreme events (Category D contingencies) studies did not identify any cascading outages if the appropriate remedial actions, such as generation and load tripping, are applied.

Transient stability studies did not identify any additional concerns beyond those identified in the reliability studies.

The results of the policy-driven assessment for the PG&E Bulk system did not identify any new transmission additions or upgrades that qualify as category 1 or category 2 elements. The identified issues for the various scenarios can be addressed with SPS or congestion management, or they appeared to be localized and will be addressed in the GIP process.

In the Humboldt area, the studies showed that the existing transmission system is adequate to accommodate additional renewable generation assumed to be developed in the four portfolios. The thermal overloads identified in this study were local issues that were being driven by high generation dispatch at 60 kV level in the starting base cases. These overloads can be addressed by reducing the Humboldt Bay 60 kV generation in the base cases. No additional transmission upgrades would be necessary in the Humboldt area to accommodate assumed levels of RPS generation in the study. The new Bridgeville-Garberville 115 kV Transmission Line Project proposed in the reliability studies would mitigate thermal and voltage concerns that may be aggravated by additional DG generation projects. It would also be necessary to maintain a certain dispatch level of the existing Humboldt Bay Power Plant to mitigate loading and voltage concerns.

In the North Coast area, the studies showed that the existing transmission system is adequate to accommodate additional renewable generation assumed to be developed in the four portfolios. No additional transmission upgrades to what have already been identified in the reliability analysis discussed in Chapter 2 will be necessary. One thermal overload that was identified in the analysis is a localized concern that will be addressed through the generator interconnection study process. The new Bridgeville-Garberville 115 kV Transmission Line Project proposed in the Humboldt area reliability studies would mitigate voltage concerns that may be exacerbated by additional generation projects.

The studies also identified high voltages under normal conditions that can be mitigated by requiring all renewable generators, including distributed generation, to provide 0.95 lead/lag power factor capability and by adjusting transformer taps on the 115/60 kV transformers in the area.

No thermal overload or voltage concerns related to the new renewable generation were identified in the North Bay area because a relatively small amount of new renewable generation in this area exists.

In the North valley area, the Delevan-Cortina 230 kV line was found to be overloaded in the base portfolio in summer peak condition. Rerating the line will mitigate the overload. Also, in the North Valley area, the Trinity-Cascade 60 kV lines were found to be overloaded in the Environmentally Constrained portfolio. These are localized concerns for which mitigation will be developed through the generator interconnection process. Similarly, in the Central Valley area some 115 kV lines in the Tesla-Salado area were found to be overloaded in Environmentally Constrained portfolio. These were also found to be localized concerns and will be addressed in the generator interconnection process.

In the Greater Bay Area thermal violations were found on the Metcalf-Morgan Hill 115 kV line as well as the Metcalf-Llagas 115 kV line. These overloads can be addressed through the generation interconnection process. Alternatively, these lines can be upgraded if found necessary to reduce the need for managing area congestion. New renewable projects in this area would be required to provide 0.95 lead/lag power factor capability to avoid excessively low voltages.

In the Fresno area, thermal and voltage issues were seen in all portfolios. Most of these issues, however, are localized concerns that will be resolved through the generator interconnection process. One issue that needs to be addressed is the overload of Los Banos-2C577SS 230 kV line.

The policy-driven studies did not identify any additional or new concerns relating to facilities in the Central Coast and Los Padres areas that did not meet applicable thermal loading and voltage performance requirements under normal and various system contingency conditions, besides those identified and addressed in the reliability assessment.

The deliverability analysis for the PG&E North area found that multiple sections of Cayetano–Lone Tree 230 kV line were overloaded under Category C contingency conditions. This thermal constraint would make the generation in the Solano CREZ undeliverable. The ISO will continue to monitor this and generation development in the area in the future planning cycles. The deliverability analysis of PG&E North area also identified the Delevan-Cortina 230 kV line to be overloaded under the Category C contingency condition. Rerating the line will mitigate the overload.

The deliverability analysis for the PG&E South area found that the renewable generation in the three portfolios is constrained by emergency overloads on three transmission lines. These overloads were also observed in the reliability analysis as well. However, the mitigation proposed for the reliability analysis will ensure the deliverability of the PGE South portfolio generation as well.

### 4.3 Policy-Driven Assessment in Southern California

This section presents the policy-driven assessment that was performed for the southern part of the ISO's controlled grid including VEA, SCE, and SDGE systems.

Tables 4.3-1, 4.3-2, and 4.3-3 summarize the renewable generation capacity modeled to meet the RPS net short in the studied areas in each portfolio.

Table 4.3-1: Renewable generation installed capacity in the Southern part of the ISO's controlled grid modeled to meet the 33% RPS net short — Commercial Interest Portfolio

Zone	Biogas	Geothermal	Large Scale Solar PV	Small Solar PV	Solar Thermal	Wind	Grand Total
Arizona			550				550
Distributed Solar - SCE				565			565
Distributed Solar - SDGE				143			143
El Dorado			150		407		557
Imperial	15	403	1015	30		252	1715
Kramer		64	320	72	250	56	762
Mountain Pass			300		345		645
Riverside East			800	9	400		1209
San Bernardino - Lucerne						42	42
Tehachapi	10		911	110		1070	2101
Grand Total	25	467	4046	928	1402	1420	8288
Arizona			550				550
Distributed Solar - SCE				565			565
Distributed Solar - SDGE				143			143
El Dorado			150		407		557
Imperial	15	403	1015	30		252	1715
Kramer		64	320	72	250	56	762
Mountain Pass			300		345		645



Zone	Biogas	Geothermal	Large Scale Solar PV	Small Solar PV	Solar Thermal	Wind	Grand Total
Riverside East			800	9	400		1209
San Bernardino - Lucerne						42	42
Tehachapi	10		911	110		1070	2101
<b>Grand Total</b>	<b>25</b>	<b>467</b>	<b>4046</b>	<b>928</b>	<b>1402</b>	<b>1420</b>	<b>8288</b>

Table 4.3-2: Renewable generation installed capacity in the southern part of the ISO's controlled grid modeled to meet the 33% RPS net short — Environmentally Constrained Portfolio

Zone	Biogas	Geothermal	Large Scale Solar PV	Small Solar PV	Solar Thermal	Wind	Grand Total
Arizona			550				550
Distributed Solar - SCE				1255			1255
Distributed Solar - SDGE				190			190
El Dorado			150		407		557
Imperial	15	30	535	30		265	875
Kramer				20	42		62
Mountain Pass			300		345		645
Riverside East			900	9	400		1309
San Bernardino - Lucerne						42	42
Tehachapi	10		986	150		1110	2256
<b>Grand Total</b>	<b>25</b>	<b>30</b>	<b>3421</b>	<b>1653</b>	<b>1194</b>	<b>1417</b>	<b>7740</b>

Table 4.3-3: Renewable generation installed capacity in the Southern part of the ISO's controlled grid modeled to meet the 33% RPS net short — High DG Portfolio

Zone	Biogas	Geothermal	Large Scale Solar PV	Small Solar PV	Solar Thermal	Wind	Grand Total
Arizona			550				550
Distributed Solar - SCE				2345			2345
Distributed Solar - SDGE				157			157
El Dorado			150		407		557
Imperial	15	30	616	30		184	875
Kramer				40	22		62
Mountain Pass			300		345		645
Riverside East			800	9	400		1209
San Bernardino - Lucerne						42	42
Tehachapi	10		911	110		1070	2101
<b>Grand Total</b>	<b>25</b>	<b>30</b>	<b>3327</b>	<b>2691</b>	<b>1174</b>	<b>1296</b>	<b>8543</b>

### Previously Identified Renewable Energy-Driven Transmission Projects

Several transmission projects that were identified in the SCE area during previous transmission planning processes to interconnect and deliver renewable generation have been included in the base cases for all portfolios. The following is a list of the projects in the SCE area along with a brief description.

#### West of Devers Project

The project involves rebuilding the four existing 220 kV transmission lines west of Devers with high capacity conductors. The completion date for this upgrade is estimated to be in 2020.

#### Tehachapi Renewable Transmission Project

The multi-phase project includes the new Whirlwind 500 kV Substation, new 500 kV and 220 kV transmission lines and upgrading existing 220 kV lines. Construction on segments 1, 2, 3, 4, 5, and 10 is completed while construction is underway on segments 6, 7, 8, 9 and 11. The expected completion date for all segments is 2016.

### Devers-Mirage 230 kV Lines Upgrade

The project consists of SCE's portion of the Path 42 project, which includes reconductoring the Devers-Mirage 230 kV transmission line. The project engineering work is currently underway with an expected in-service date is 2014.

The Path 42 project also consists of IID's portion, which includes upgrading the Coachella Valley-Mirage 230 kV transmission line and upgrading the Coachella Valley-Ramon-Mirage 230 kV transmission line.

### El Dorado-Lugo Series Caps Upgrade

This project includes upgrading El Dorado-Lugo Series Caps and terminal equipment at both ends of the 500 kV line. The expected in-service date is 2016.

### Lugo-Eldorado 500 kV line reroute

This project includes rerouting a short segment of the Lugo-Eldorado 500 kV line so that it is not adjacent to the Lugo-Mohave 500 kV line. The expected in-service date is 2016.

### Coolwater-Lugo 230 kV Transmission Line Project

This project consists of a new 230 kV transmission line between Coolwater and Lugo substations. A Certification of Public Necessity and Convenience (CPCN) application for this project was filed by SCE on August 28, 2013.

## **4.3.1 Southern California Policy-Driven Powerflow and Stability Assessment Results and Mitigations**

The 2013-2014 renewable portfolio amounts in southern California are similar to the 2012-2013 portfolios. Therefore, the 2012-2013 transmission planning process policy-driven powerflow and stability analysis is still generally applicable for the 2013-2014 transmission planning process. However, the ISO identified transfer capability limitations on WECC Path 46, West of River (WOR), in the 2013-2013 transmission planning process that were recommended for further analysis and was the focus of the policy-driven powerflow and stability analysis in southern California. The following summarizes the study results identifying facilities in the SCE area that did not meet system performance requirements with WOR flows at 10,351 MW. The discussion includes proposed mitigation plans for the system performance concerns.

Table 4.3-4: Summary of study results for Commercial Interest portfolio

Contingency	Overloaded Facility	Overload % or Voltage Dip
ECO N-1 with SPS, ECO-Miguel with SPS, and WITHOUT cross-tripping	TJI-230 to OtayMesa 230 kV line	105%
IV-ECO N-1 with SPS, ECO-Miguel with SPS, and WITH cross-tripping	Suncrest – Sycamore 230 kV lines #1 and #2	101%
	Suncrest 230 and 500 kV buses voltage dip	9%
Basecase	Miguel – BayBlvd 230 kV line	102%
Lugo-Mohave 500 kV and Lugo-Eldorado 500 kV lines	Victorville-Lugo 500 kV line	105%
Lugo-Mohave 500 kV and Lugo-Eldorado 500 kV lines (with safety net)	Victorville-Lugo 500 kV line	101%

The loading and voltage concerns identified in the study for the Commercial Interest portfolio were mainly caused by renewable generation along the borders of California and Arizona and Nevada, and the import through the West of River transmission path.

Comparing Tables 4.3–1 to 4.3–3 for all three portfolios, it was found that there were no significant differences in renewable generation along the eastern borders of California. Also, no significant difference was found on the import flow on West of River for three portfolios. Therefore, it can be concluded that the violations observed for the Commercial Interest portfolio can also be observed for Environmental Constrained and High DG portfolios without additional detailed studies, although the severity of violations may slightly vary.

Comparing the 2013-2014 renewable portfolios to ones studied in the 2012-2013 transmission planning process, it can be concluded that there are not significant increases in renewable generation. The most significant change causing the loading and voltage concerns is the retirement of SONGS. As described in Chapter 2, the ISO is recommending a flow control device on the Imperial Valley-ROA 230 kV line as part of the mitigation plan for addressing needs in the LA Basin and San Diego areas. That mitigation along with some reactive support addresses the loading and voltage concerns identified in the table above.

The Lugo-Mohave 500 kV and Lugo-Eldorado 500 kV common corridor simultaneous contingency has a WECC exemption from being considered as adjacent circuits and therefore this outage is considered a Category D contingency. The impacts of the Category D contingency are substantially mitigated by a generation dropping safety net scheme.

Based on the study results and analysis above, the following mitigations are needed.

- Category 1 policy-driven upgrades

- 1) rely on the flow control device on Imperial Valley–ROA 230 kV line already identified as a reliability solution and install a 300 MVar dynamic reactive device at the Suncrest 230 kV bus. Estimated cost for the dynamic reactive device is \$65 million based on similar proposed projects.
- 2) alternative to item 1)
  - upgrade Miguel–Bay Blvd to have higher normal rating (1176 MVA). The estimated cost \$12 million
  - build a third 230 kV line out of Suncrest substation. The estimated cost is \$260 million based on similar proposed projects
    - upgrade Los Coches 138 kV to 230 kV
    - build new 230 kV line from Suncrest to Los Coches
    - loop-in Miguel to Sycamore to Los Coches
  - install 450 MVar dynamic reactive device at Suncrest 230 kV. The estimated cost is \$100 million based on similar proposed projects.
- Category 2 policy-driven upgrades
  - no Category 2 upgrades were identified in this planning cycle.

### 4.3.2 SCE and VEA Area Policy-Driven Deliverability Assessment Results and Mitigations

#### Base portfolio Deliverability Assessment Results

Deliverability assessment results for SCE and VEA area are discussed below.

#### North of Inyokern Constraint

Deliverability of the new renewable resources north of Inyokern is limited by the overloads on Inyo phase shifter and Inyo–Control 115 kV line. Upgrading the Inyo phase shifter to +/-60 degree angle regulation could control the normal condition flow from Control to Inyo below 20 MW and thus mitigate the overloads. The constraint is localized in nature and should be addressed through the generator interconnection process.

Table 4.3-5: Base portfolio deliverability assessment results — North of Inyokern Constraint

Overloaded Facility	Contingency	Flow
Inyo 115kV phase shifter	Base Case	155.73%
	Inyo - Owenscon 230 kV No. 1	176.28%
	Rinaldi - Victorville 500kV No. 1 & Rinaldi - Adelanto 500kV No. 1	166.33%
Control - Inyo 115kV No. 1	Base Case	110.72%
	Inyo - Owenscon 230 kV No. 1	129.57%
	Control - Inyokern - Coso 115kV No. 1	128.57%
	Control - Inyokern 115kV No. 1	128.36%
	Rinaldi - Victorville 500kV No. 1 & Rinaldi - Adelanto 500kV No. 1	120.41%
	Lugo - Victor 230kV No. 1 and No. 2	107.50%
	Lugo 500/230kV bank No. 1 or No. 2	103.58%
Inyo 230/115 bank No. 1 or 2	Inyo - Owenscon 230 kV No. 1	103.63%
Lugo-Mohave 500 kV and Lugo-Eldorado 500 kV lines	Victorville-Lugo 500 kV line	132.53%
	Market Place - Adelanto 500kV No. 1	105.48%
Lugo-Mohave 500 kV and Lugo-Eldorado 500 kV lines (with safety net)	Victorville-Lugo 500 kV line	127.24%
	Market Place - Adelanto 500kV No. 1	101.72%

Table 4.3-6: North of Inyokern Deliverability Constraint

<b>Constrained Renewable Zones</b>	Kramer (north of Ransberg); Nevada C (Control)
<b>Total Renewable MW Affected</b>	114.30 MW
<b>Deliverable MW w/o Mitigation</b>	< 20 MW
<b>Mitigation</b>	Upgrade Inyo phase shifter
	Local constraint to be addressed in generation interconnection process

Kramer A-Bank Constraint

Deliverability of the new renewable resources interconnecting in the Kramer and north 115 kV system is limited by the contingency overloads on Kramer 230/115 kV transformer banks (A-Banks). The overloads can be mitigated by installing an SPS to trip generation. The constraint is localized in nature and should be addressed through the generator interconnection process.

Table 4.3-7: Base portfolio deliverability assessment results — Kramer A-Bank Constraint

<b>Overloaded Facility</b>	<b>Contingency</b>	<b>Flow</b>
Kramer 230/115kV bank No. 1	Kramer - Victor 115kV No. 1 & Kramer - Victor - Roadway 115kV No. 1	119.25%
Kramer 230/115kV bank No. 2	Kramer - Victor 115kV No. 1 & Kramer - Victor - Roadway 115kV No. 1	102.81%

Table 4.3-8: Kramer A-Bank Deliverability Constraint

<b>Constrained Renewable Zones</b>	Kramer (115kV); Nevada C (Control)
<b>Mitigation</b>	SPS tripping generation
	Local constraint to be addressed in generation interconnection process

West of Coolwater 115kV Constraint

Deliverability of the new renewable resources interconnecting in the Coolwater to Ivanpah 115 kV system is limited by the contingency overloads on 115 kV transmission lines between Coolwater and Kramer. The overloads can be mitigated by installing an SPS to trip generation. The constraint is localized in nature and should be addressed through the generator interconnection process.

Table 4.3-9: Base portfolio deliverability assessment results — West of Coolwater 115 kV Constraint

Overloaded Facility	Contingency	Flow
Coolwater - Tortilla - Segs2 115kV No. 1 (Tortilla leg)	Kramer - Coolwater 115kV No. 1	116.41%
Kramer - Coolwater 115kV No. 1	Coolwater - Tortilla - Segs2 115kV No. 1	109.74%

Table 4.3-10: West of Coolwater 115kV Deliverability Constraint

<b>Constrained Renewable Zones</b>	Kramer (Coolwater 115kV); Mountain Pass
<b>Mitigation</b>	SPS tripping generation
	Local constraint to be addressed in generation interconnection process

East of Coolwater 115 kV Constraint

Deliverability of the new renewable resources interconnecting in the Coolwater 115 kV system is limited by the voltage instability following outages of two parallel 115 kV lines from Coolwater to Kramer. The voltage instability can be mitigated by installing an SPS to trip generation. The constraint is localized in nature and should be addressed through the generator interconnection process.

Table 4.3-11: Base portfolio deliverability assessment results — East of Coolwater 115kV Constraint

Overloaded Facility	Contingency	Flow
Ivanpah - Mountain Pass - Baker - Dunnsiding - Coolwater 115kV No. 1	Kramer - Coolwater 115kV No. 1 & Coolwater - Tortilla - Segs2 115kV No. 1	voltage instability
	Kramer - Coolwater 115kV No. 1 & Kramer - Tortilla 115kV No. 1	voltage instability



Table 4.3-12: East of Coolwater 115 kV Deliverability Constraint

<b>Constrained Renewable Zones</b>	Kramer (Coolwater 115kV)
<b>Mitigation</b>	SPS tripping generation
	Local constraint to be addressed in generation interconnection process

Antelope–Neenach–Bailey Constraint

Deliverability of the new renewable resources interconnecting at the Neenach 66 kV substation is limited by the normal overload of Bailey–Neenach–Westpac 66 kV transmission line, as well as contingency overloads of Bailey–Neenach–Westpac 66 kV and Antelope–Neenach 66 kV transmission lines. The overloads can be mitigated by reconfiguring Antelope to Bailey 66 kV lines into a radial configuration and reconductoring Bailey–Neenach–Westpac 66 kV transmission line. The constraint is localized in nature and should be addressed through the generator interconnection process.

Table 4.3-13: Base portfolio deliverability assessment results — Antelope-Neenach-Bailey 115 kV Constraint

<b>Overloaded Facility</b>	<b>Contingency</b>	<b>Flow</b>
Antelope - Neenach 66kV	Bailey - Neenach - Westpac 66kV No. 1	180.10%
Bailey - Neenach - Westpac 66kV No. 1 (Bailey leg)	Antelope - Neenach 66kV	116.18%
Bailey - Neenach - Westpac 66kV No. 1 (Neenach leg)	Base Case	103.34%
	Antelope - Neenach 66kV	130.77%

Table 4.3-14: Antelope–Neenach–Bailey Deliverability Constraint

<b>Constrained Renewable Zones</b>	Tehachapi (Neenach 66kV)
<b>Total Renewable MW Affected</b>	128.7 MW
<b>Deliverable MW w/o Mitigation</b>	< 70 MW
<b>Mitigation</b>	Open breaker at Neenach on Antelope - Neenach 66kV line and reconductor Bailey - Neenach - Westpac 66kV line
	Local constraint to be addressed in generation interconnection process

Julian Hinds–Mirage Constraint

There are renewable generators in the base portfolio assumed to be interconnecting in the Blythe area, inside Riverside East renewable zone, and outside the ISO controlled grid. These generators cause overloads on the Julian Hinds–Mirage 230 kV line. The constraint is localized in nature and should be addressed through the affected system process associated with the interconnection of generators outside ISO controlled grid.

Table 4.3-15: Base portfolio deliverability assessment results — Julian Hinds-Mirage  
115 kV Constraint

Overloaded Facility	Contingency	Flow
J. Hinds – Mirage 230kV No. 1	Base Case	104.18%

Table 4.3-16: Julian Hinds — Mirage Deliverability Constraint

Mitigation	
	Re-configure generation interconnection
	Local constraint caused by renewables outside ISO Controlled Grid and to be addressed in generation interconnection process

Desert Area Constraint

The renewable generators in the Desert Area cause overloads in the neighboring utility's transmission system. To reduce the loop flow through the neighboring utility system, it is recommended to upgrade the series capacitor and terminal equipment at the Mohave substation for Lugo–Mohave 500 kV line and operate the Lugo–Mohave 500 kV line with series capacitors at Lugo and Mohave under normal condition. This constraint limits deliverability in a wide electrical area that covers several renewable zones and has been identified as an area deliverability constraint.

Table 4.3-17: Base portfolio deliverability assessment results — Desert Area Constraint

Overloaded Facility	Contingency	Flow
Market Place - Adelanto 500kV No. 1	Victorville - McCullough 500kV No. 1 & 2	101.62%
Lugo - Victorville 500kV No. 1	Lugo - Eldorado 500kV No. 1	104.22%

Table 4.3-18: Desert Area Deliverability Constraint

<b>Constrained Renewable Zones</b>	Eldorado, Mountain Pass, Riverside East, Imperial (SDG&E), Arizona, Tehachapi (Big Creek/Ventura), Distributed Solar, non-CREZ
<b>Total Renewable MW Affected</b>	3078 MW
<b>Deliverable MW w/o Mitigation</b>	1260 ~ 2840 MW <sup>30</sup>
<b>Mitigation</b>	Upgrade series cap and terminal equipment at Mohave on Lugo - Mohave 500kV line. Operate Lugo - Mohave 500kV line at 70% compensation level.
<b>Deliverable MW w/ Mitigation</b>	2820 ~ 6070 MW

### Analysis of Other Portfolios

The need for transmission upgrades to relieve the Desert Area deliverability constraint is analyzed for other renewable portfolios by comparing the generation behind the deliverability constraint. The results are shown in the table below. The generation capacity listed for each renewable zone represents only the generators contributing to the deliverability constraint and may be lower than the total capacity in the renewable zone.

<sup>30</sup> The Desert Area constraint has been identified in previous TPP studies and generation interconnection studies. It consists of a group of deliverability constraints that impact the Desert Area. The most limiting constraint has changed from Red Bluff–Devers 500 kV double line outage to Lugo–Eldorado 500 kV line outage after the Lugo–Eldorado 500 kV line upgrade was approved in the 2012-2013 TPP cycle. The generators interconnecting at Red Bluff and west of Imperial Valley are no longer behind the constraint. Therefore, the deliverable MW is lower than the previous identified amount for Desert Area due to the factor that only a subset of the generators previously behind the Desert Area constraint are still behind the constraint.

Table 4.3-19: Portfolios requiring the transmission upgrade

Transmission Upgrade	Renewable Zones	Commercial Interest (MW)	High DG (MW)	Env. Constrained (MW)	Needed for Portfolios
Lugo - Mohave series cap and terminal equipment upgrade	Mountain Pass	645	645	645	Commercial Interest
	Eldorado	557	557	557	
	Riverside East	500	500	600	
	Arizona	290	290	290	High DG
	Tehachapi	73	73	73	Env. Constrained
	Distributed Solar - SCE	150	333	166	
	SDGE	863	668	668	

### Recommendation

The following two transmission upgrades are needed for the base portfolio, plus at least one other portfolio:

- Lugo–Mohave series cap and terminal equipment upgrade.

This upgrade relieves the identified area deliverability constraint and is recommended for approval as a Category 1 policy-driven upgrade.

### Transmission Plan Deliverability with Recommended Transmission Upgrades

With the above recommended transmission upgrade, an estimate of the generation deliverability supported by the existing system and approved transmission upgrades is listed in Table 4.3-20. Transmission plan deliverability is estimated based on the area deliverability constraints identified in recent generation interconnection studies without considering local deliverability constraints. For study areas not listed in Table 4.3-20, the transmission plan deliverability is greater than the MW amount of generation in the ISO interconnection queue up to and including queue cluster 6.

Table 4.3-20: Deliverability for Area Deliverability Constraints in SCE area

Area Deliverability Constraint	Renewable Zones	Deliverability (MW)
Desert Area Lugo – Victorville flow limit	Mountain Pass	2,820 ~ 6,070
	Eldorado	
	Arizona	
	Tehachapi (Big Creek and Ventura)	
	Distributed Solar – SCE (Big Creek and Ventura)	
	SDGE	
Barre - Lewis flow limits	Riverside East	510 ~ 3,170
	Distributed Solar – SCE (East LA Basin)	
	Kramer	
Kramer – Lugo flow limits	Nevada C	860 ~ 1,100
	Kramer	
	San Bernardino - Lucerne	
Pisgah - Lugo flow limits	Pisgah	670 ~ 830
	San Bernardino - Lucerne	
Lugo AA Bank capacity limit	Nevada C	1,270 ~ 1,380
	Kramer	
	San Bernardino - Lucerne	
	Pisgah	

### 4.3.3 SDG&E Area Policy-Driven Deliverability Assessment Results and Mitigations

#### Base Portfolio Deliverability Assessment Results

Deliverability assessments in previous transmission planning cycles have demonstrated that the dispatch of generation at Encina was a pivotal assumption associated with certain deliverability constraints in the San Diego area. This deliverability assessment was performed with the assumption that existing Encina units 1, 2 and 3 would be retired and repowered with 260 MW at Encina 230 kV and 260 MW at Encina 138 kV. Existing Encina units 4 and 5 were assumed to be retired in the study, but a sensitivity study was performed to determine if the addition of more generation in the northwest San Diego area would mitigate any of the identified violations, or create any additional deliverability constraints.

Due to the retirement of SONGS, new generation was modeled in the deliverability assessment, consisting of 308 MW at Otay Mesa 230 kV and 100 MW at Carlton Hills 138 kV. Along with this generation, the following network upgrades were modeled:

- Miguel Tap Reconfiguration Project—Reconfigure TL23041 and TL23042 at Miguel Substation to create two Otay Mesa-Miguel 230 kV lines; and
- current limiting series reactor (3.1 ohm) on the Otay Mesa-Tijuana 230 kV line.

The results of the assessment are discussed below.

#### Miguel-Bay Boulevard 230 kV Constraint

Deliverability of new renewable resources in the Imperial zone is limited by the following Category A, B and C overloads:

- The Category A overload on Miguel-Bay Boulevard 203 kV line has been previously identified in the C3C4 Phase II study and is expected to be mitigated through the GIP.
- Category C overloads on Miguel-Bay Boulevard 230 kV line can be mitigated by installing an SPS to trip generation. This SPS has been identified in the C1C2 and C3C4 studies. However, because of the removal of Encina and SONGS generation, tripping new generation at Otay Mesa and Imperial Valley is not sufficient. Some existing generation either at Otay Mesa or Imperial Valley would need to be tripped as well. Generation at Otay Mesa has a higher effectiveness factor compared to Imperial Valley, therefore it is recommended that existing Otay Mesa generation participate in this SPS. An alternative to tripping existing generation is to add more generation in the northwest San Diego area or curtail MIC in southern California.

Table 4.3-21: Base portfolio deliverability assessment results — Miguel-Bay Boulevard 230 kV Deliverability Constraint

Overloaded Facility	Contingency	Flow
Miguel-Bay Boulevard 230 kV	Base Case	110%
	Miguel-Mission 230 kV #1 and #2	114%
	Miguel-Mission 230 kV #2 and Jamul-Telecanyon-Miguel 138 kV	104%
	Miguel-Mission 230 kV and Los Coches-Jamul 138 kV	102%
	Sycamore-Palomar 230 kV and Sycamore-Penasquitos 230 kV	108%

Table 4.3-22: Miguel-Bay Boulevard 230 kV Deliverability Constraint

<b>Constrained Renewable Zones</b>	Imperial
<b>Total Renewable MW Affected</b>	1083 MW
<b>Deliverable MW w/o Mitigation</b>	< 100 MW

Miguel 500/230 kV Transformers Constraint

Deliverability of new renewable resources in the Imperial zone is limited by Category B overloads on the Miguel 500/230 kV transformers. The overloads can be mitigated by an SPS to trip IV generation and by relying on short term ratings of the transformers.

Table 4.3-23: Base portfolio deliverability assessment results — Miguel 500/230 kV Transformers Deliverability Constraint

Overloaded Facility	Contingency	Flow
Miguel 500/230 kV #1	Miguel 500/230 kV #2	111%
Miguel 500/230 kV #2	Miguel 500/230 kV #1	108%

Imperial Valley Deliverability Constraint

The change of flow patterns caused by the loss of the San Onofre Nuclear Generating Station has adversely impacted the deliverability of new renewable resources in the Imperial zone which are now limited by Category B and C overloads on 500 and 230 kV facilities in the Imperial Valley/Ocotillo/ECO/Suncrest and Otay Mesa/Tijuana/La Rosita areas. The less severe overloads can be mitigated by modifying the existing IV SPS to trip generation.

However, an SPS to trip 1150 MW of IV generation is not sufficient to eliminate the overloads on the Otay Mesa-Tijuana 230 kV line following Category B contingencies and requires utilizing the CFE cross-trip, which then results in overloads on the Sycamore-Suncrest 230 kV lines. Similar loading concerns were identified in the powerflow and stability studies focusing on the West of River transmission overloads. However, in those results the Sycamore-Suncrest 230 kV line overloads were less severe than in the deliverability assessment and the addition of a flow control device on the CFE system (identified as needed as a reliability solution in Chapter 2) was sufficient to solve all identified constraints. Unfortunately, in the more localized deliverability analysis, modeling the flow control device only reduces the overloads on the Sycamore-Suncrest 230 kV lines to about 102 percent. One option to mitigate overloads on the Sycamore-Suncrest 230 kV lines is to build a new Suncrest-Los Coches 230 kV line; however, with this alternative, an upgrade to the Ocotillo-Suncrest 500 kV series capacitor and terminal equipment may also be needed. A second option is the addition of Delany-Colorado River 500 kV line, which is being recommended for approval as an economically driven project in this plan.

With the CFE flow control device installed and operated to minimize normal loop flow through the CFE system, the IV SPS will need to be further modified to trip generation for outages of the Suncrest 500/230 kV transformers to prevent overloads on the parallel transformer and for outages of the IV 500/230 kV transformers to prevent overloads on parallel transformers.

Outages of IV-OCO and OCO-Suncrest 500 kV lines create overloads on the IV-ECO and ECO-Miguel 500 kV lines. Tripping 1,150 MW of generation reduces the loading on the lines to about 108 percent. Based on transmission availability estimates from the ISO, the CPUC RPS Calculator input data assumed that 1,715 MW of renewable generation could be accommodated in the Imperial zone without overloading the transmission system west of Imperial Valley. However, this information was based on having SONGS in-service. With SONGS retired no additional renewable generation can be made deliverable in the Imperial zone until considering the reliability mitigations being proposed in this transmission plan. Adding the flow control device would result in accommodating 800 MW of Imperial zone renewable generation. Adding the Delaney-Colorado River 500 kV<sup>31</sup> project would increase the deliverable amount to about 1,000 MW.

The loadings in the table below assume no SPS and no cross-trip unless otherwise noted.

---

<sup>31</sup> The Delaney-Colorado River 500 kV line was not approved by the ISO Board of Governors at the March 20, 2014 ISO Board meeting.



Table 4.3-24: Base portfolio deliverability assessment results — Otay Mesa-Tijuana 230 kV Deliverability Constraint

Overloaded Facility	Contingency	Flow
Otay Mesa-Tijuana 230 kV	Imperial Valley-ECO 500 kV	118%
	ECO-Miguel 500 kV	118%
Sycamore-Suncrest 230 kV #1	ECO-Miguel 500 kV (with SPS and with cross trip)	114%
	Imperial Valley-ECO 500 kV (with SPS and with cross trip)	114%
Sycamore-Suncrest 230 kV #2	ECO-Miguel 500 kV (with SPS and with cross trip)	114%
	Imperial Valley-ECO 500 kV (with SPS and with cross trip)	114%
IV-ECO 500 kV	Suncrest-Ocotillo 500 kV	102%
	Suncrest-Sycamore 230 kV #1 and #2	102%
	Imperial Valley-Ocotillo 500 kV	101%
ECO-Miguel 500 kV	Suncrest-Ocotillo 500 kV	102%
	Suncrest-Sycamore 230 kV #1 and #2	102%
	Imperial Valley-Ocotillo 500 kV	101%
Imperial Valley-La Rosita 230 kV	ECO-Miguel 500 kV	104%
	Imperial Valley-ECO 500 kV	106%
Rumorosa-La Rosita 230 kV	Imperial Valley-ECO 500 kV	105%
	ECO-Miguel 500 kV	103%

Otay Mesa-Miguel 230 kV Deliverability Constraint

The assessment identified Category B and C overloads on the Otay Mesa-Miguel 230 kV lines. The overloads can be mitigated by modifying the existing Otay Mesa SPS due to Miguel Tap Reconfiguration Project, and to include generation tripping for N-1 outages since the existing SPS only trips generation for N-2 outage. The need for the modifications to the existing SPS was identified in the GIP studies. Installing a flow control device on the CFE parallel system to control the loop flow through CFE could avoid the need for the new N-1 SPS.

Table 4.3-25: Base portfolio deliverability assessment results — Otay Mesa-Miguel 230 kV Deliverability Constraint

Overloaded Facility	Contingency	Flow
Otay Mesa-Miguel 230 kV #1	Otay Mesa-Miguel 230 kV #2	113%
Otay Mesa-Miguel 230 kV #2	Otay Mesa-Miguel 230 kV #1	113%
Otay Mesa-Tijuana 230 kV	Otay Mesa-Miguel 230 kV #1 and #2	116%
CFE lines (RUM-ROA, ROA-HRA, RUM-HRA, MEP-TOY 230 kV)		104% - 145%

Encina-San Luis Rey 230 kV Deliverability Constraint

A sensitivity deliverability assessment that assumed additional generation in the northwest San Diego area identified the following potential deliverability concerns.

Overloads on Encina Tap-San Luis Rey and Encina-San Luis Rey 230 kV lines can be mitigated by reconductoring the lines or by an SPS to trip generation.

The overload on the San Luis Rey 138/69 kV transformer was identified in GIP and can be mitigated by an SPS to trip generation.

Table 4.3-26: Base portfolio deliverability assessment sensitivity results — Encina-San Luis Rey 230 kV Deliverability Constraint

Overloaded Facility	Contingency	Flow
Encina Tap-San Luis Rey 230 kV	Encina-San Luis Rey 230 kV	111%
	Encina-San Luis Rey 230 kV and Encina-Penasquitos 230 kV	109%
	Palomar-Sycamore 230 kV and Encina-San Luis Rey-Palomar 230 kV	104%
San Luis Rey 138/69 kV	Encina-San Luis Rey 230 kV and Encina-San Luis Rey-Palomar 230 kV	129%

Table 4.3-27: Encina-San Luis Rey 230 kV Deliverability Constraint

Encina-San Luis Rey 230 kV Deliverability Constraint	
Total San Diego MW Affected	6,094 MW
Deliverable MW w/o Mitigation	5,300 ~ 5,700 MW

**Transmission Plan Deliverability with Recommended Transmission Upgrades**

With the above recommended transmission upgrades, an estimate of the generation deliverability supported by the existing system and approved transmission upgrades is listed in Table 4.3-28. Transmission plan deliverability is estimated based on the area deliverability constraints identified in recent generation interconnection studies without considering local deliverability constraints. For study areas not listed in Table 4.3–28, the transmission plan deliverability is greater than the MW amount of generation in the ISO interconnection queue up to and including queue cluster 6.

Table 4.3-28: Deliverability for Area Deliverability Constraints in SDG&E area

Area Deliverability Constraint	Renewable Zones	Deliverability (MW)
Otay Mesa Area Constraint	Imperial	2,200 ~ 3,000
	San Diego South	
	SDGE – Non-CREZ	
Encina/San Luis Rey 230 kV Constraint	Arizona	2,500 ~ 3,500
	Imperial	
	San Diego South	
	SDGE – Non-CREZ	
San Luis Rey/San Onofre 230 kV Constraint	Arizona	3,700 ~ 4,700
	Imperial	
	San Diego South	
	SDGE – Non-CREZ	
East of Miguel Constraint	Imperial	See “Imperial Valley Deliverability Constraint” section above
	San Diego South	

#### 4.3.4 Southern California Policy-Driven Conclusions

The policy deliverability assessment for the SCE/VEA area has identified the Lugo–Mohave series capacitor and terminal upgrade as a Category 1 policy-driven upgrade.

The powerflow, stability and deliverability assessment for the SDGE area has identified the need for a flow control device on the Imperial Valley-ROA 230 kV line (already recommended in this transmission plan as a reliability-driven project) along with a 300 Mvar SVC at Suncrest 230 kV bus. The flow control device is also needed to mitigate the impact on the transmission system due to the retirement of SONGS. These upgrades, along with the Delaney-Colorado River 500 kV<sup>32</sup> line project identified as needed for economic benefits, allow for the deliverability of 1000 MW of the 1715 MW of the renewable generation in the Imperial zone in the renewable portfolios. Because the remaining limiting constraint is a thermal overload on a 500 kV line, it is expected that a major transmission upgrade could be needed to ensure deliverability of the entire portfolio amount. Although the ISO studied the reliability benefits of several major new upgrade alternatives such as transmission lines from the Imperial area into the coastal load area which could be expected to also result in enough transmission capability to accommodate the 1715 MW of Imperial zone renewable generation, further study is needed in the next planning cycle to develop the most cost effective comprehensive transmission plan for this area meeting these policy-driven needs through the ISO's transmission planning process.

---

<sup>32</sup> The Delaney-Colorado River 500 kV line was not approved by the ISO Board of Governors at the March 20, 2014 ISO Board meeting.

**Intentionally left blank**

## Chapter 5

# 5 Economic Planning Study

### 5.1 Introduction

The economic planning study simulates WECC system operations over an extended period in the planning horizon and identifies potential congestion in the ISO controlled grid. The study objective is to find economically driven network upgrades to increase production efficiency and reduce ratepayer costs.

The study uses the unified planning assumptions and was performed after completing the reliability-driven and policy-driven transmission studies. Network upgrades identified as needed for grid reliability and renewable integration were taken as inputs and modeled in the economic planning database. In this way, the economic planning study started from a “feasible” system that meets reliability standards and policy needs. Then, the economic planning study sought to identify additional network upgrades that are cost-effective to mitigate grid congestion and increase production efficiency.

The studies used a production simulation as the primary tool to identify grid congestion and assess economic benefits created by congestion mitigation measures. The production simulation is a computationally intensive application based on security-constrained unit commitment (SCUC) and security-constrained economic dispatch (SCED) algorithms. The simulation is conducted for 8,760 hours for each study year, which are total number of hours in a year. The potential economic benefits are quantified as reduction of ratepayer costs based on the ISO Transmission Economic Analysis Methodology (TEAM).<sup>33</sup>

### 5.2 Study Steps

The economic planning study is conducted in two consecutive steps as shown in Figure 5.2-1.

In the first study step (i.e., congestion identification), a production simulation is conducted for each hour of the study year. Identified congestion is tabulated and ranked by severity, which is expressed as congestion costs in dollars and congestion duration in hours. Based on the simulation results and after considering stakeholder requests for economic studies as described in tariff Section 24.3.4.1 and the Transmission Planning BPM Section 3.2.3, five high-priority studies were determined.

In the second study step (i.e., congestion mitigation), congestion mitigation plans are evaluated for each of the high-priority studies. Using the production simulation and other means, the ISO quantified economic benefits for each identified network upgrade alternative. Last, a cost-benefit analysis is conducted to determine if the identified network upgrades are economic. Net benefits

---

<sup>33</sup> Transmission Economic Assessment Methodology (TEAM), California Independent System Operator, June 2004, <http://www.caiso.com/docs/2004/06/03/2004060313241622985.pdf>

are compared with each other where the net benefits are calculated as the gross benefits minus the costs to compare multiple alternatives that would address identified congestion issues. The most economical solution is the alternative that has the largest net benefit.

Figure 5.2-1: Economic planning study – two steps

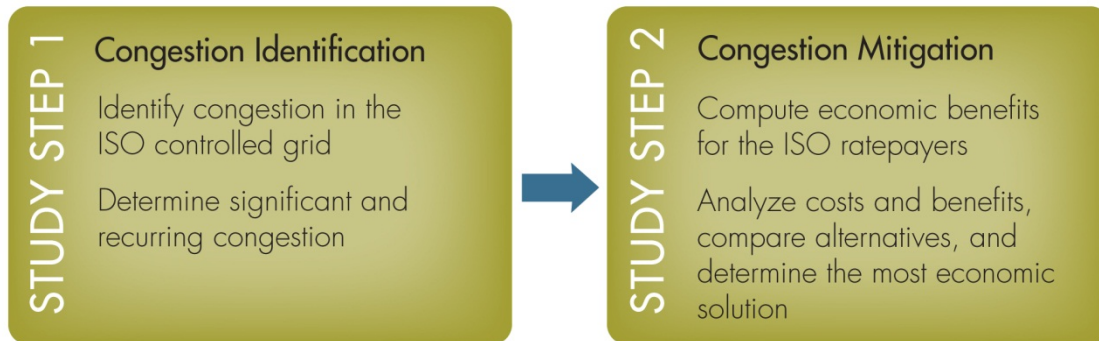

### 5.3 Technical Approach

Production simulation plays a major role in quantifying the production cost reductions that are often associated with congestion relief. Traditional power flow analysis is also used in quantifying other economic benefits such as system and local capacity savings.

Different components of benefits are assessed and quantified under the economic planning study.

First, production benefits are quantified by the production simulation that computes unit commitment, generator dispatch, locational marginal prices and transmission line flows over 8,760 hours in a study year. With the objective to minimize production costs, the computation balances supply and demand by dispatching economic generation while accommodating transmission constraints. The study identifies transmission congestion over the entire study period. In comparison of the “pre-project” and “post-project” study results, production benefits can be calculated from savings of production costs or ratepayer payments.

The production benefit includes three components of ratepayer benefits: consumer payment decrease; increasing load serving entity owned generation revenues; and increasing transmission congestion revenues. Such an approach is consistent with the requirements of tariff section 24.4.6.7 and TEAM principles. Production benefit is also called energy benefit. As the production simulation models both energy and reserve dispatch, we prefer to call the calculated benefit a “production benefit”.

Second, capacity benefits are also assessed. Capacity benefits types include system resource adequacy (RA) savings and local RA savings. The system RA benefit corresponds to a situation where a network upgrade for an importing transmission facility leads to a reduction of ISO system resource requirements, provided that out-of-state resources are less expensive to procure than in-state resources. The local capacity benefit corresponds to a situation where an



upgraded transmission facility that leads to a reduction of local capacity requirement in a load area.

In addition to the production and capacity benefits, any other benefits — where applicable and quantifiable — can also be included. However, it is not always viable to quantify social benefits into dollars.

Once the total economic benefit is calculated, the benefit is weighed against the cost. To justify a proposed network upgrade, the required criterion is that the ISO ratepayer benefit needs to be greater than the cost of the network upgrade. If the justification is successful, the proposed network upgrade may qualify as an economically driven project.

The technical approach of economic planning study is depicted in Figure 5.3-1. The economic planning study starts from an engineering analysis with power system simulations (using production simulation and snapshot power flow analysis). The engineering analysis phase is the most time consuming part of the study. Based on results of the engineering analysis, the study enters the economic evaluation phase with a cost-benefit analysis, which is a financial calculation that is generally conducted in spreadsheets.

Figure 5.3-1: Technical approach of economic planning study

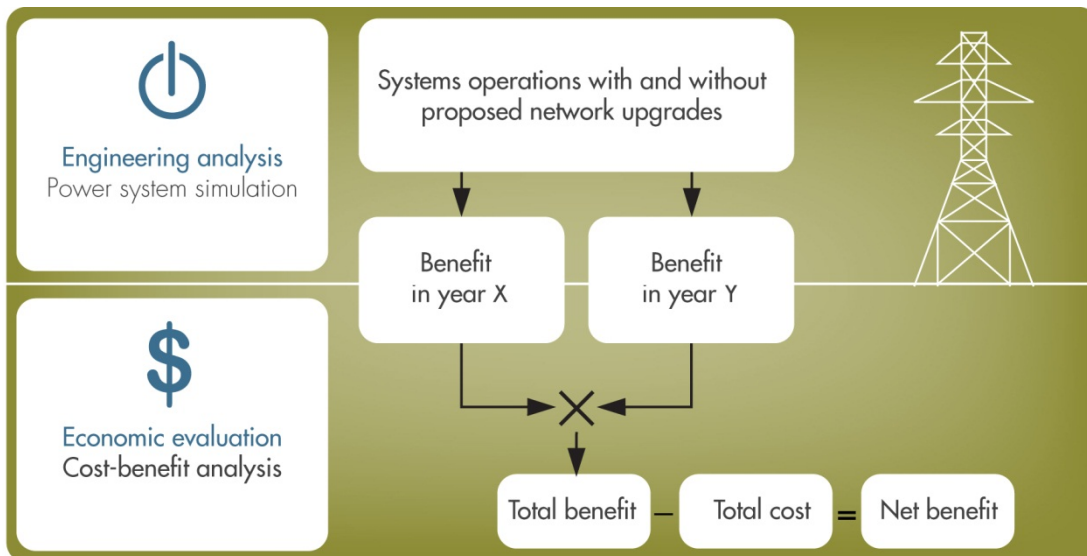

## 5.4 Tools and Database

The ISO used the software tools listed in for this economic planning study.

Table 5.4-1: Tools used for this economic planning study

Program name	Version	Date	Functionality
ABB GridView™	8.3	13-Nov-2013	The software program is a production simulation tool with DC power flow to simulate system operations in a continuous time period, e.g. 8,760 hours in a study year
GE PSLF™	18.0_01	24-Oct-2011	The software program is an AC power flow tool to compute line loadings and bus voltages for selected snapshots of system conditions, e.g. summer peak or spring off-peak

This study used the WECC production simulation model as a starting database. The database is often called the Transmission Expansion Planning Policy Committee (TEPPC) dataset. For this study, the ISO used the “2022 PC1” dataset released on May 2, 2012.

Based on the TEPPC “2022 PC1” datasets, the ISO developed the 2018 and 2023 base cases for the production simulation. In creation of the 5<sup>th</sup> year (2018) and 10<sup>th</sup> year (2023) base cases, the ISO applied numerous updates and additions to model the California power system in more detail. Those modeling updates and additions are described in Section 5.5 (Study Assumptions).

Figure 5.4-1 shows the process of developing the ISO base cases.

Figure 5.4-1: Database setup

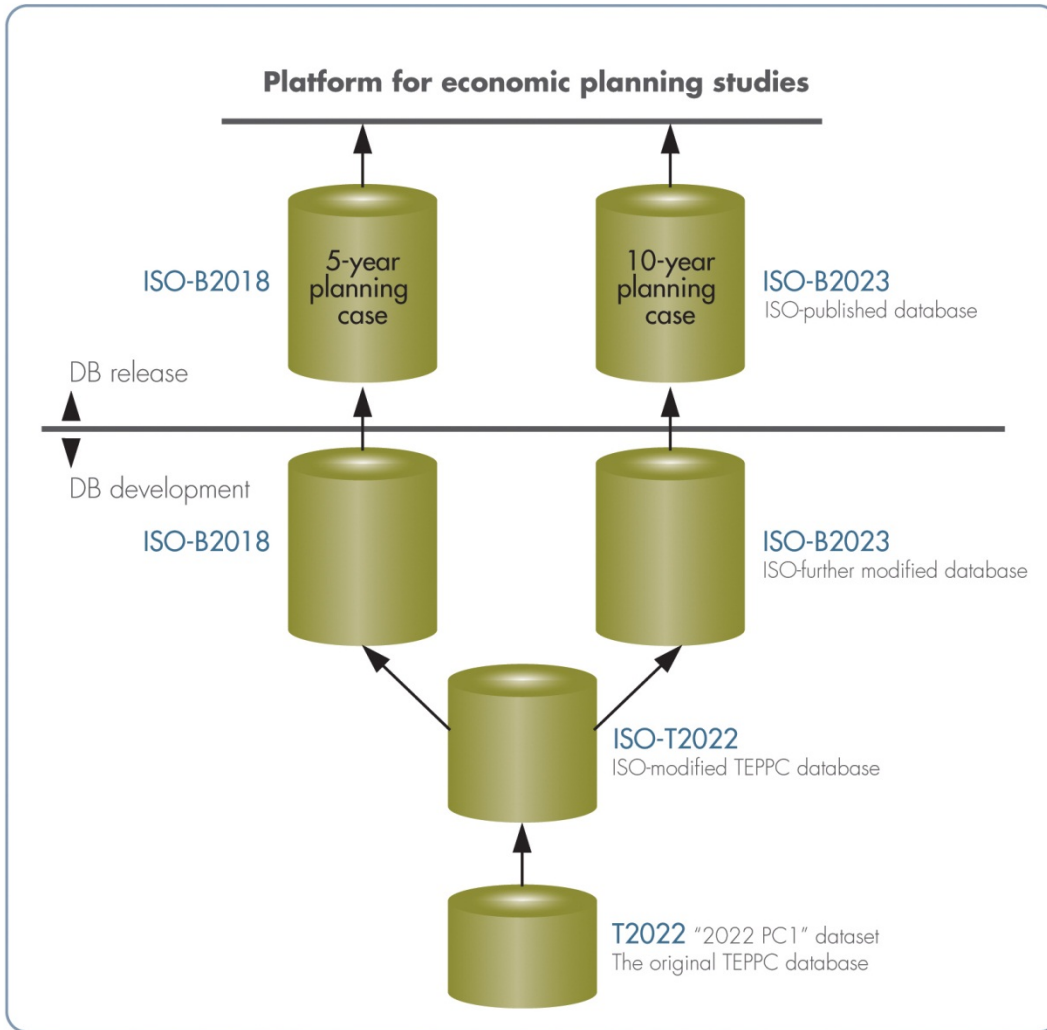

## 5.5 Study Assumptions

This section summarizes major assumptions used in the economic planning study. The section also highlights the ISO enhancements and modifications to the TEPPC database.

### 5.5.1 System modeling

The ISO made major topology changes in system modeling to the TEPPC database and modeled balancing authority areas (BAAs), i.e., control areas in the WECC system. Figure 5.5-1 shows the change in modeling control areas.

Figure 5.5-1: Modeling control areas

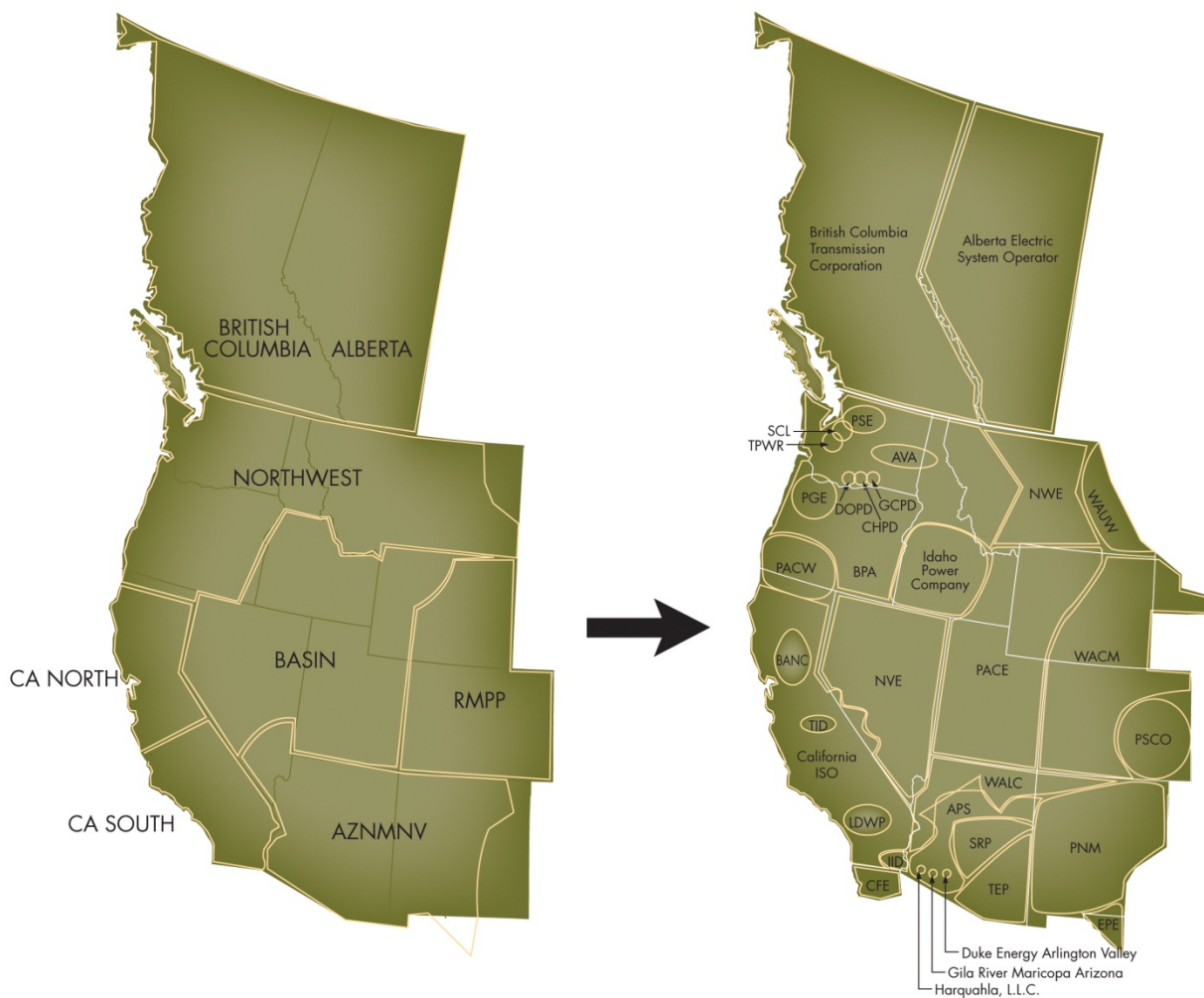

The TEPPC database represented eight geographic regions that did not quite function as BAAs. The ISO changed the eight geographic regions to 31 BAAs. The WECC system has 37 BAAs. The ISO embedded five small BAAs (HGBA, GRMA, AVBA, GRBA and GWA) in the

surrounding bigger BAAs. Also, the ISO merged the two Nevada utility areas (SPPC and NEVP) into one BAA representing NV Energy (NVE).<sup>34</sup>

Specifically, with the California power system, the TEPPC database defined only two geographic regions: CALIF\_NORTH and CALIF\_SOUTH. However, the ISO changed the two geographic regions into five BAAs represented by the following:

- California ISO (CISO)
- Balancing Authority Northern California (BANC)
- Turlock Irrigation District (TID)
- Los Angeles Department Water and Power (LADWP)
- Imperial Valley Irrigation District (IID).

Because the ISO changed the eight geographic regions into 31 BAAs, the 13 hurdle interfaces were changed from the original TEPPC dataset to 60 wheeling interfaces in the ISO database. The wheeling rates act as tariff-based barriers between different BAAs. With the inter-BAA wheeling interfaces, the economic dispatch is less optimal than a perfect dispatch of the total system.

Last, five reserve sharing groups were overlaid on top of the BAAs. The reserve sharing groups are the greater BPA area, Pacific Northwest and Basin, Rocky Mountain, Desert Southwest and Balancing Authority of Northern California (BANC).

The system modeling is consistent with the framework of WECC Phase 2 EIM study.<sup>35</sup> However, the ISO made some improvements, such as combining northern and southern Nevada areas into a single BAA.

### 5.5.2 Load demand

As a norm for economic planning studies, the production simulation models 1-in-2 heat wave load in the system to represent typical or average load conditions. The ISO developed base cases used load modeling data from the following sources.

- In modeling California load, the study used the CEC demand forecast. In the TEPPC database, the California load model was based on the CEC 2011 IEPR demand forecast dated February 2012. The ISO replaced that load model with the latest CEC demand forecast data published in September 2012.

---

<sup>34</sup> The Nevada utility area (SPPC and NEVP) will be combined into one control area under NV Energy (NVE) when the One Nevada Line (ON Line) goes into service. The ON Line is currently under construction and expected to be operational in 2013.

<sup>35</sup> WECC report: "WECC EDT Phase 2 EIM Benefits Analysis & Results (October 2011 Revision)", prepared for Western Electricity Coordinating Council on October 11, 2011 by Energy Environmental Economics, Inc.

- In modeling load for other areas in the WECC system, the study used 2012 forecast data from the WECC Load and Resource Subcommittee (LRS), which comes from different utilities in the WECC. In the TEPPC database, the load model was based on LRS 2011 data. The ISO replaced that load model with the latest LRS 2012 data.

Thirty-nine load areas were represented in the WECC production simulation model. In the ISO developed base cases, one load area was added increasing load areas to 40. Valley Electric Association (VEA) joined the ISO-controlled grid on January 10, 2013. The VEA was part of the NEVP load area. In the new model, the ISO created this as a new area and included it in the ISO BAA. Figure 5.5-2 shows the 40 WECC load areas represented in the ISO-modified database. While the load area diagram is presented below, it must be noted that this does not imply that the production simulation is conducted as a “bubble” model. Rather, the production simulation is a complete nodal model and the full-WECC database models all transmission lines in the system.

Figure 5.5-2: Load areas represented in the WECC production simulation model

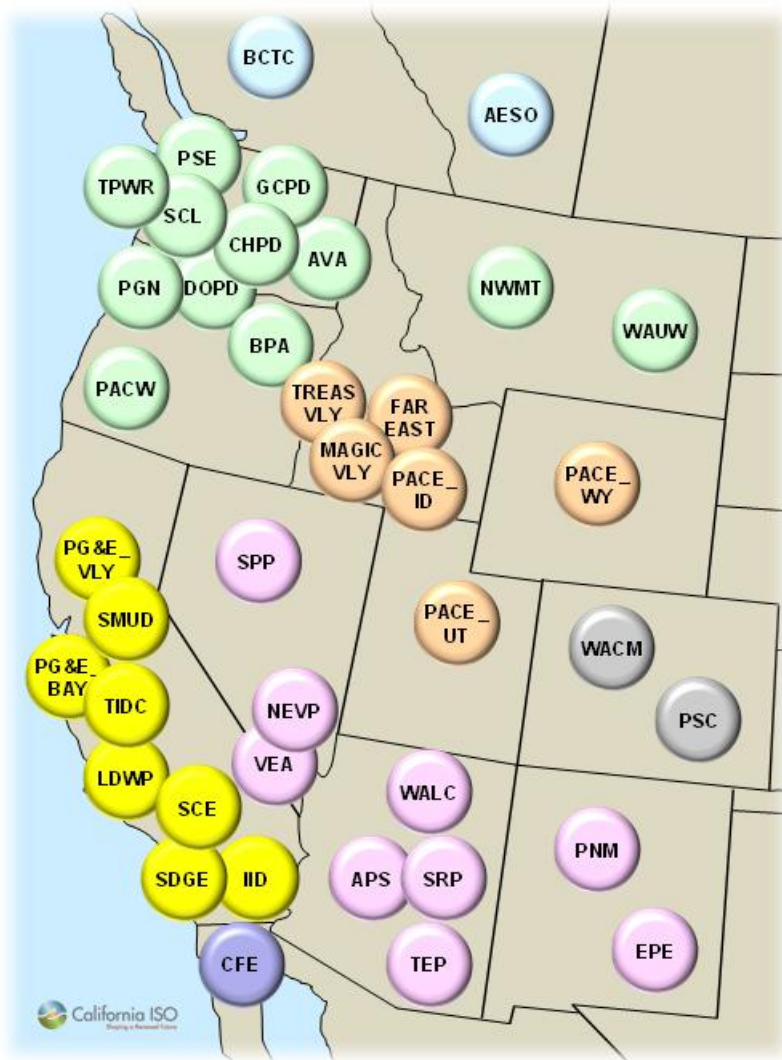

Each load area has an hourly load profile for the 8,760 hours in the production simulation model. Individual bus load is calculated from the area load using a load distribution pattern that was imported from a power flow base case. In the original TEPPC database only one summer load distribution pattern was modeled. The ISO enhanced the load distribution model by adding three more load distribution patterns of spring, autumn and winter. Thus, the developed ISO base cases have four load distribution patterns for different seasons.

### 5.5.3 Generation resources

For renewables, the original TEPPC dataset modeled the “Modified Cost-Constrained case” for the California 33 percent RPS based on 2011 CPUC portfolios, which the ISO replaced with the new 2013 CPUC/CEC portfolios. In addition, the study modeled two additional RPS portfolios as sensitivity cases. The modeled renewable net-short portfolios are listed in Table 5.5-1. Please refer to Chapter 4 for the detailed descriptions of the renewable portfolios.

Table 5.5-1: Renewable net-short portfolios

Acronym	Renewable Portfolios	Study Case
CI	Commercial Interest portfolio	Base case
EC	Environmentally constrained portfolio	Sensitivity case
HD	High distributed generation portfolio	Sensitivity case

There are no major discrepancies between the TEPPC database and the ISO model for thermal generation. In other words, the TEPPC database has covered all the known and credible thermal resources in the planning horizon.

### 5.5.4 Transmission assumptions and modeling

The entire WECC system was represented in a nodal network in the production simulation database. Transmission limits were enforced on individual transmission lines, paths (i.e., flowgates) and nomograms.

The original TEPPC database did not enforce transmission limits for 500 kV transformers and 230 kV lines. The ISO enforced those transformer limits for this study throughout the system and enforced the 230 kV line limits in California. Such modifications were made to make sure that transmission line flows stayed within their rated limits.

Another important enhancement is the transmission contingency constraints, which the original TEPPC database did not model. In the updated database, the ISO modeled contingencies on the 500 kV and 230 kV voltage levels in the California transmission grid to make sure that in the

event of losing one (and sometimes multiple) transmission facility, the remaining transmission facilities would stay within their emergency limits.

Economic planning studies start from a feasible system that meets reliability standards and policy requirements. To establish a feasible system, needed reliability-driven and policy-driven network upgrades are modeled in the base case. The ISO selected some major network upgrades and modeled them into the base case. Those selected network upgrades were usually above the 115 kV level and were deemed to have impacts on the power flows in the bulk transmission system. Network upgrades on 115 kV and lower voltage levels were assumed to be related local problems with no significant impact on the bulk transmission system.

Some of approved network upgrades were not included in the TEPPC database. The ISO rectified the database by adding those missing network upgrades. The added network upgrades are listed in Tables 5.5-2 through 5.5-6.

Table 5.5-2: Reliability-driven network upgrades added to the database model<sup>36</sup>

#	Project approved or conceptual	Utility	ISO-approval	Operation year
1	Occidental of Elk Hills 230 kV interconnection	PG&E	TP2008-2009	2010
2	Morro Bay 230/115 kV transformer #7	PG&E	TP2009-2010	2009
3	Fresno interim reliability project (reconductoring 230 kV lines)	PG&E	TP2009-2010	2014
4	Ashlan – Gregg and Ashlan – Herndon 230 kV line reconductor	PG&E	TP2010-2011	2015
5	Gill Ranch gas storage interconnection	PG&E	TP2010-2011	2011
6	Moraga – Castro Valley 230 kV capacity upgrade	PG&E	TP2010-2011	2013
7	Midway – Kern PP 230 kV lines 1-3 & 4 capacity increase	PG&E	TP2010-2011	2013

<sup>36</sup> The “Reliability-driven network upgrade” table lists major network upgrades of 230 kV and above. In addition, the ISO modeling additions included network upgrades of lower voltage levels. For brevity, minor and lower voltage upgrades are not listed here. For details of the listed network upgrades, please refer to relevant ISO Transmission Plan reports.



#	Project approved or conceptual	Utility	ISO-approval	Operation year
8	Fulton 230/115 kV transformer project	PG&E	TP2010-2011	2014
9	Rio Oso – Atlantic 230 kV line #2	PG&E	TP2010-2011	2015
10	Red Bluff 230 kV Substation	PG&E	TP2010-2011	2016
11	Morro Bay – Mesa 230kV line	PG&E	TP2010-2011	2018
12	Tulucay 230/60 kV transformer #1 replacement	PG&E	TP2011-2012	2014
13	Borden voltage support	PG&E	TP2011-2012	2019
14	Del Amo – Ellis loop-in	SCE	TP2011-2012	2013
15	Barre – Ellis 230kV reconfiguration	SCE	TP2012-2013	2014
16	Northern Fresno 115 kV area reinforcement	PG&E	TP2012-2013	2018
17	Series reactor on Warnerville – Wilson 230 kV line	PG&E	TP2012-2013	2017
18	Gates 500/230 kV transformer #2	PG&E	TP2012-2013	2017
19	Gates – Gregg 230 kV line	PG&E	TP2012-2013	2022
20	Contra Costa Substation 230 kV switch replacement	PG&E	TP2012-2013	2015
21	Arco 230/70 kV transformer #2	PG&E	TP2012-2013	2013
22	Gregg – Herndon No.2 230 kV line circuit breaker upgrade	PG&E	TP2012-2013	2015
23	Kearney 230/70 kV transformer addition	PG&E	TP2012-2013	2015
24	Kearney – Herndon 230 kV line reconductor	PG&E	TP2012-2013	2017
25	Lockeford – Lodi Area 230 kV Development	PG&E	TP2012-2013	2017

Table 5.5-3: Policy-driven network upgrades added to the database model

#	Project approved or conceptual	Utility	ISO approval	Operation year
1	IID-SCE Path 42 upgrade	SCE	TP2010-2011	2013
2	Warnerville – Belotta 230 kV line reconductoring	PG&E	TP2012-2013	2017
3	Lugo – Eldorado series capacitors and terminal equipment upgrade	SCE	TP2012-2013	2016
4	Sycamore – Penasquitos 230 kV line	SDG&E	TP2012-2013	2017

Table 5.5-4: GIP-related network upgrades added to the database model

#	Project approved or conceptual	Utility	Note	Operation year
1	South of Contra Costa reconductoring	PG&E	ISO LGIA	2012
2	West of Devers 230 kV series reactors	SCE	ISO LGIA	2013 (Till 2019)
3	West of Devers 230 kV reconductoring	SCE	ISO LGIA	2019
4	Cool Water – Lugo 230 kV line	SCE	Renewable delivery	2018

Table 5.5-5: Other network upgrades added to the database model

#	Project approved or conceptual	Utility	Note	Operation year
1	PDCI Upgrade Project	BPA	Under construction	2015
2	Barren Ridge Renewable Transmission Project	LADWP	LADWP-approved	2017
3	Scattergood – Olympic transmission line	LADWP	LADWP-approved	2015
4	Cottle 230 kV ring bus, load relocation and removal of tie to Bellota – Warnerville	PG&E	PG&E maintenance project	2012
5	Merchant 230 kV reconfiguration project	SCE	ISO approved	2012
6	Bob Tap 230 kV switchyard and Bob Tap – Eldorado 230 kV line	VEA	ISO approved	2015

Table 5.5-6: Assumed network upgrades added to the database model<sup>37</sup>

#	Project approved or conceptual	Utility	Reason	Operation year
1	Upgrade Inyo 115 kV phase shifter	SCE	Renewable delivery	2018

<sup>37</sup> In the “Assumed network upgrades” table, the listed network upgrades are needed to establish a feasible database to meet reliability standards and policy needs. These assumptions are for database modeling purposes and do not imply that the network upgrades will be approved and constructed.

### 5.5.5 Financial Parameters Used in Cost-Benefit Analysis

A cost-benefit analysis was performed for each economic planning study, in which the total costs were weighed against the total benefits of the proposed network upgrades.

All costs and benefits are expressed in U.S. dollars in 2012 values. The costs and benefits are in net present values, which are discounted to the assumed operation year of the studied network upgrade. By default, the proposed operation year is 2018 unless specially indicated.

#### 5.5.5.1 Cost analysis

Total cost is the net present value in the proposed operation year of total annual revenue requirement. The total revenue requirement includes impacts of capital cost, tax expenses, O&M expenses and other relevant costs.

In calculating the total cost, the following financial parameters were used:

- asset depreciation horizon = 50 years;
- return on equity = 11 percent<sup>38</sup>;
- O&M = 2 percent;
- property tax = 2 percent;
- inflation rate = 2 percent; and
- cost discount rate = 7 percent (real) and sensitivity at 5 percent (real)

In the initial planning stage, however, most proposed study subjects do not provide detailed annual revenue requirement information. Instead, they have lump sum capital cost estimates and the ISO uses typical financial information to convert them into annual revenue requirements, and from there calculates the present value of the annual revenue requirements stream.

As an approximation used for screening purposes, the present value of the utility's revenue requirement is calculated as the capital cost multiplied by a "CC-to-RR multiplier". Currently, the multiplier is 1.45 and is based on prior experiences of the utilities in the California ISO. As noted in the following sections, detailed analysis has been performed for select projects demonstrating high benefit-to-cost ratios rather than relying on screening-level assumptions in the event a recommendation for approval of the project.

#### 5.5.5.2 Benefit analysis

Total benefit refers to the present value of the accumulated yearly benefits over the economic life of the proposed network upgrade. The yearly benefits are discounted to the present value in the proposed operation year before the dollar value is accumulated towards the total economic

---

<sup>38</sup> At the time the ISO's TEAM methodology was initially developed in 2004, a return on equity of 12% was estimated. Since that time, regulatory decisions on return on equity have been trending more towards 10%. To remain conservative in its analysis, the ISO has made a modest adjustment to 11% for more detailed cost-benefit analysis.

benefit. Because of the discount, the present worth of yearly benefits diminishes very quickly in future years.<sup>39</sup>

In this economic planning study, engineering analysis determined the yearly benefits through production simulation and power flow analysis. Production simulation was conducted for the 5<sup>th</sup> planning year and 10<sup>th</sup> planning year. Therefore, year 2018 and 2023 benefits were calculated. For the intermediate years between 2018 and 2023 the benefits were estimated by linear interpolation. For years beyond 2023 the benefits were estimated by extending the 2023 year benefit with an assumed escalation rate.

The following financial parameters were used in calculating yearly benefits for use in the total benefit:

- economic life of new transmission facilities = 50 years;
- economic life of upgraded transmission facilities = 40 years;
- benefits escalation rate beyond year 2023 = 0 percent (real); and
- benefits discount rate = 7 percent (real) and sensitivity at 5 percent (real)

### 5.5.5.3 *Cost-benefit analysis*

Once the total cost and benefit are determined a cost-benefit comparison is made.

Consistent with the TEAM methodology, a social discount rate was considered in discounting the annual revenue requirements ultimately paid by customers and the economic benefits that would accrue to customers on an annual basis. A 7% (real) discount rate was applied as a very conservative base assumption for both costs and benefits. Further, for projects considered for approval, a sensitivity of 5% (real) was calculated to provide a broader perspective on the anticipated net benefits.

For a proposed upgrade to qualify as an economic project, the benefit has to be greater than the cost. In other words, the net benefit (calculated as cost minus gross benefit) has to be positive.

If there are multiple alternatives, the one that has the largest net benefit is considered the most economical solution.

---

<sup>39</sup> Discount of yearly benefit into the present worth is calculated by  $b_i = B_i / (1 + d)^i$ , where  $b_i$  and  $B_i$  are the present and future worth respectively;  $d$  is the discount rate; and  $i$  is the number of years into the future. For example, given a yearly economic benefit of \$10 million, if the benefit is in the 30<sup>th</sup> year, its present worth is \$1.3 million based a discount rate of 7 percent. Likewise, if the benefit is in the 40<sup>th</sup> or 50<sup>th</sup> years, its present worth is \$0.7 million or \$0.3 million, respectively. In essence, going into future years the yearly economic benefit worth becomes very small.

## 5.6 Congestion Identification and Scope of High Priority Studies

This section describes the congestion simulation results and scope of high priority studies.

### 5.6.1 Congestion identification

Table 5.6-1 lists congested transmission facilities identified from the production simulation.

Table 5.6-1: Congested facilities in the ISO-controlled grid

#	Transmission Facilities	Year 2018		Year 2023	
		Congestion Duration (Hours)	Congestion Cost (\$M)	Congestion Duration (Hours)	Congestion Cost (\$M)
1	Path 66 (COI) nomogram	3	0.003	-	-
2	Path 25 (PacifiCorp – PG&E 115 kV Interconnection)	488	0.488	651	0.651
3	Contra Costa Sub – Contra Costa 230 kV line	4	0.009	15	0.042
4	US Wind Power – JRW – Cayetano 230 kV line, subject to loss of Contra Costa – Las Positas 230 kV line	-	-	1	0.016
5	Midway – Vincent 500 kV line #1 or #2	1	0.001	4	0.014
6	Midway – Vincent 500 kV line #1, subject to loss of #2 line, or vice versa	69	0.628	28	0.247
7	Midway – Vincent 500 kV line #1 or #2, subject to loss of Midway – Whirlwind line	111	0.337	37	0.195
8	Path 26 (Northern – Southern California)	692	7,218	468	4,773
9	Path 26 north-to-south Operating Transfer Capability	5	0.010	8	0.020
10	Vincent 500/230 kV transformer #1	6	0.039	4	0.035

#	Transmission Facilities	Year 2018		Year 2023	
		Congestion Duration (Hours)	Congestion Cost (\$M)	Congestion Duration (Hours)	Congestion Cost (\$M)
11	Villa Park – Lewis 230 kV line, subject to loss of Villa Park - Barre 230 kV line	2	0.005	-	-
12	Lewis – Barre 230 kV line, subject to loss of Villa Park – Barre 230 kV line	70	0.649	-	-
13	Barre - Ellis 230 kV line, subject to loss of Hassayampa – North Gila 500 kV lines	2	0.004	-	-
14	Litehipe – Hinson 230 kV line, subject to loss of La Fresno - Redondo 230 kV line	3	0.006	-	-
15	Julian Hinds – Mirage 230 kV	83	0.144	7	0.015
16	Kramer – Lugo 230 kV line #1 and #2	623	11.721	85	0.575
17	Inyo 115 kV phase shifter	769	0.572	760	0.578
18	Control – Inyokern 115 kV line #1	-	-	34	0.021
19	Control – Tap710 115 kV line	-	-	458	0.021
20	Miguel 500/230 kV transformer #1, subject loss of transformer #2	-	-	1	0.297
21	SCIT limits	23	1.213	2	0.080

Table 5.6-2 summarizes the potential congestion from the previous table into 10 areas and ranks its severity, based on average congestion costs.

Table 5.6-2: Simulated congestion in the ISO-controlled grid

#	Area	Utility	Duration (hours)		Average Congestion Cost (\$M)
			Year 2018	Year 2023	
1	Path 26 (Northern-Southern California)	PG&E, SCE	878	545	6.890
2	North of Lugo (Kramer – Lugo 230 kV)	SCE	623	85	6.148
3	North of Lugo (Inyo 115 kV)	SCE	769	1,252	0.734
4	SCIT limits	SCE, SDG&E	23	2	0.647
5	LA metro area	SCE	77	-	0.323
6	Path 25 (PacifiCorp/PG&E 115 kV Interconnection)	PG&E, PacifiCorp	448	651	0.117
7	Mirage – Devers area	SCE	83	7	0.080
8	Vincent 500 kV transformer	SCE	6	4	0.037
9	Greater Bay Area (GBA)	PG&E	4	16	0.026
10	Path 66 (COI)	BPA, PG&E	3	-	0.002

### 5.6.2 Scope of high-priority studies

After evaluating identified congestion (listed in Table 5.6-2) and reviewing stakeholders' study requests, consistent with tariff section tariff Section 24.3.4.2, the ISO selected the high priority studies, which are listed Table 5.6-3.



Table 5.6-3: High-priority studies

#	ID	Subject	Notes
1	P26-3	Build new Midway – Vincent 500 kV line #4	110 miles
2	NWC-1	Upgrade existing PDCI by 300 MW increase of rating	-
3	SWC-1	Build new Harry Allen – Eldorado 500 kV line	60 miles
4	SWC-2	Build new Delaney – Colorado River 500 kV line	110 miles
5	SWC-3	Build new North Gila – Imperial Valley 500 kV line #2	80 miles

The five high priority studies are shown in Figure 5.6-1 (a geographic diagram) and Figure 5.6-2 (an electrical diagram), respectively.

Figure 5.6-1: Geographic diagram showing subjects of the economic planning studies

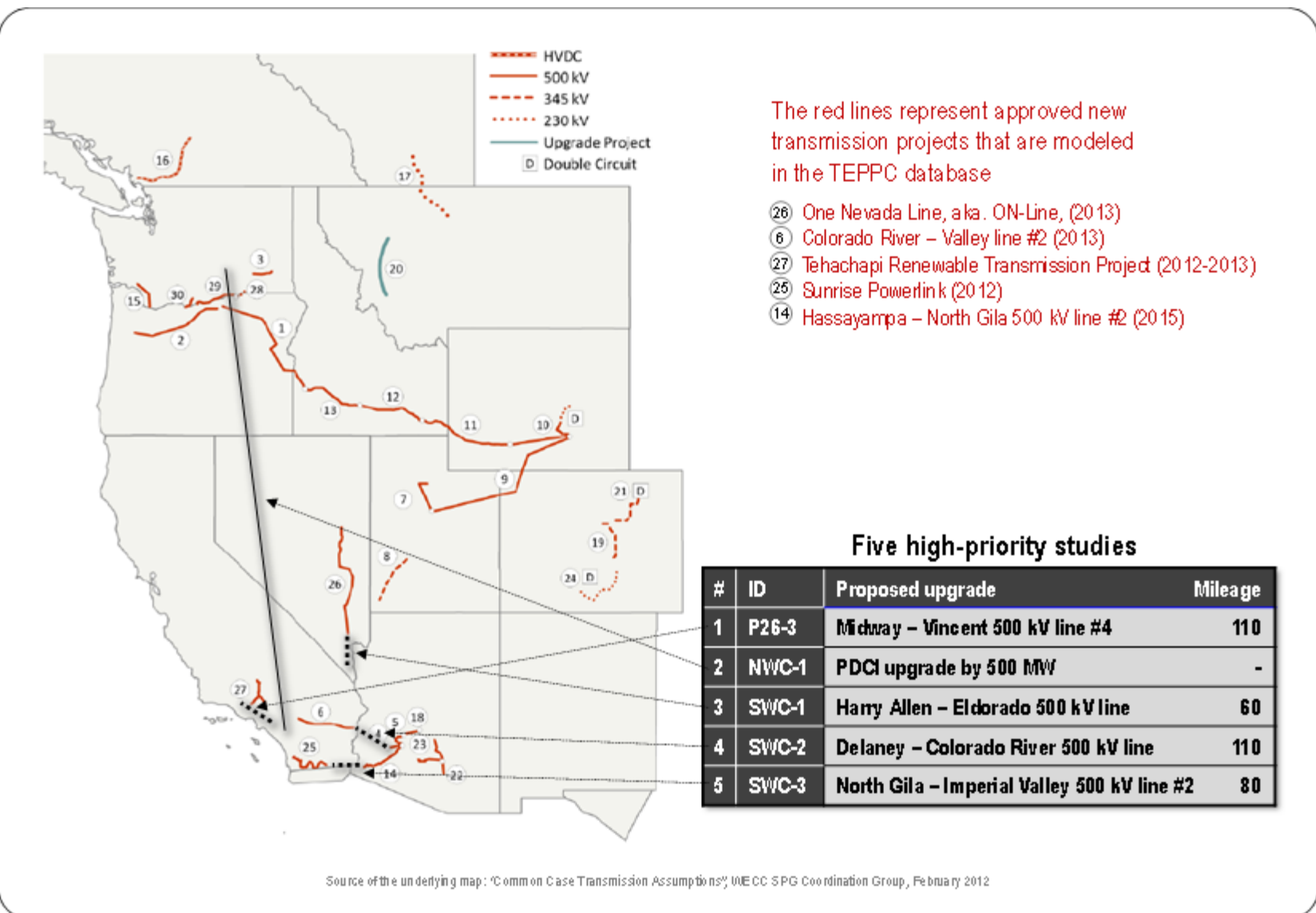
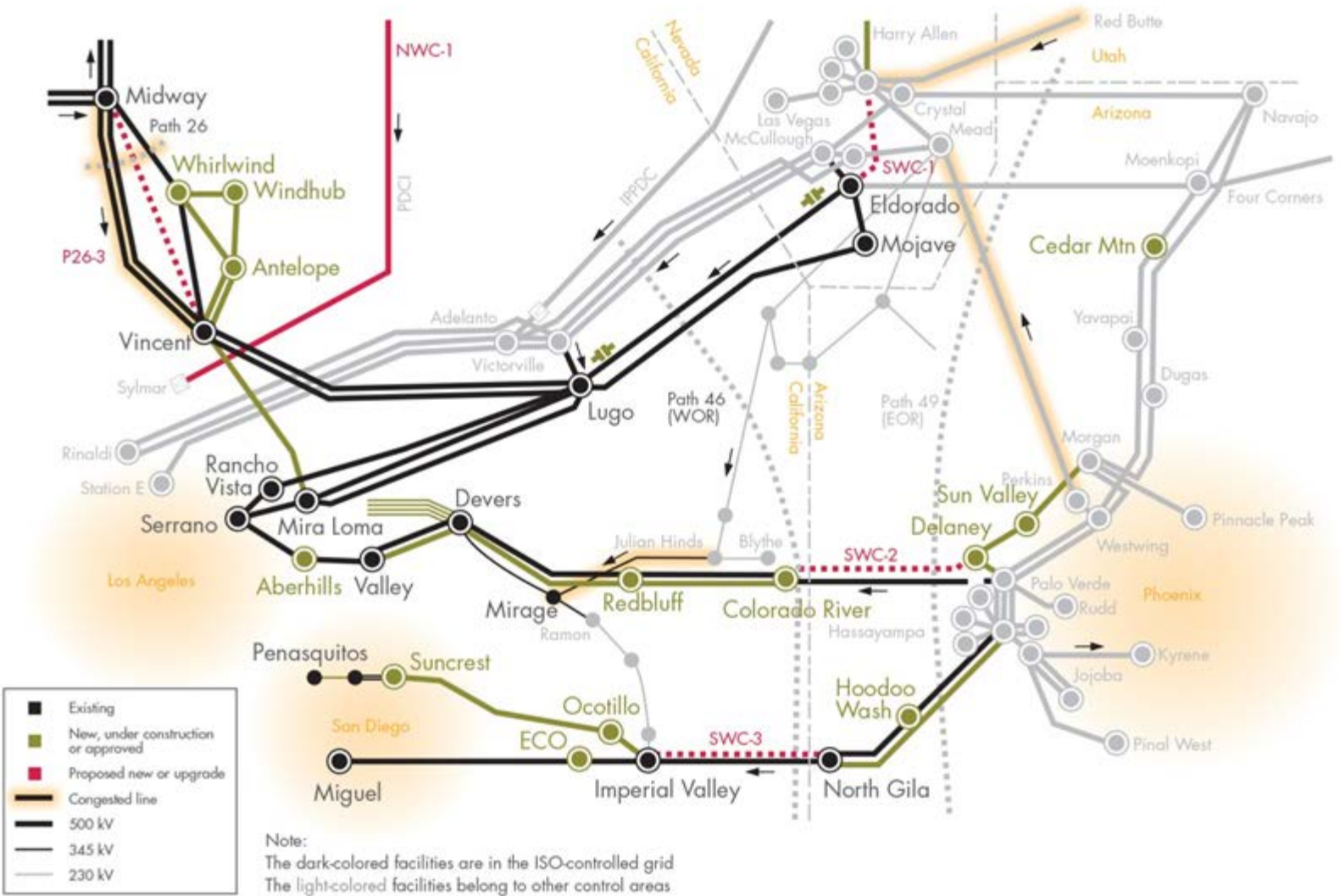

Figure 5.6-2: System diagram showing subjects of economic planning studies



## 5.7 Congestion Mitigation and Economic Assessment

Congestion mitigation is the second step in the economic planning study. With a focus on high-ranking congestion, this study step produced proposed network upgrades, evaluated their economic benefits and weighed the benefits against the costs to determine if the network upgrades were economical.

This section describes congestion mitigation analysis and economic assessment study results of the following identified network upgrades:

1. Midway – Vincent 500 kV line #4;
2. PDCI upgrade by 300 MW increase of rating;
3. Harry Allen – Eldorado 500 kV line;
4. Delaney – Colorado River 500 kV line; and
5. North Gila – Imperial Valley 500 kV line #2.

The five high-priority studies are described in the following subsections.

**5.7.1 Midway – Vincent 500 kV line #4**

This section describes the economic planning study of building the new Midway – Vincent 500 kV line #4.

Path 26 is a transmission link that connects the northern and southern utility areas in the state. Figure 5.7-1 shows 500 kV transmission lines in the Path 26 area.

Figure 5.7-1: One-line diagram of the Path 26 area

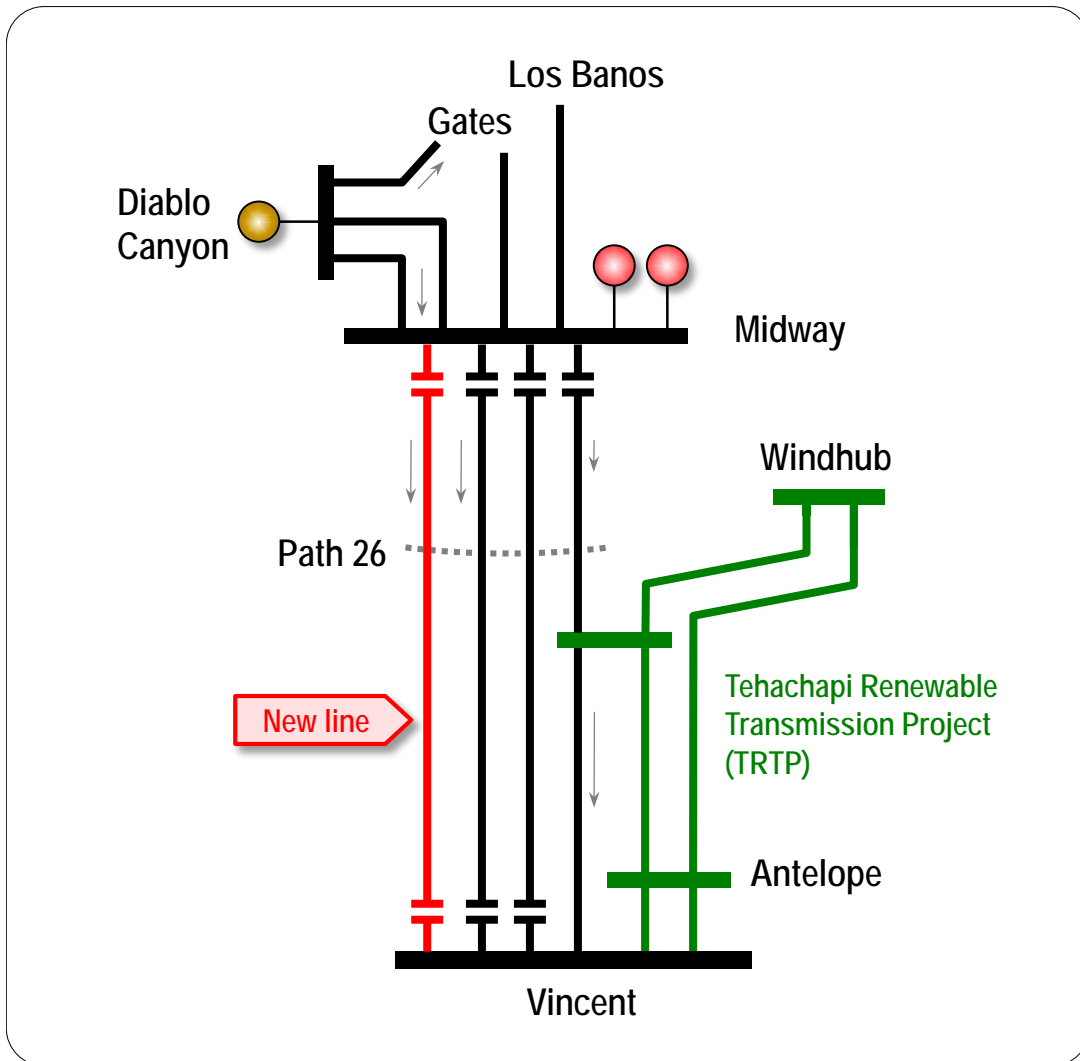

### 5.7.1.1 Congestion analysis

Table 5.7-1 lists simulation results of congestion hours before and after adding the proposed Midway – Vincent 500 kV line #4.

Table 5.7-1: Congestion hours before and after adding the Midway – Vincent 500 kV line #4

#	Transmission Facilities	Year 2018		Year 2023	
		Before	After	Before	After
1	Path 66 (COI) nomogram	3	4	-	-
2	Path 25 (PacifiCorp – PG&E 115 kV Interconnection)	488	571	651	687
3	Contra Costa Sub – Contra Costa 230 kV line	4	4	15	14
4	US Wind Power – JRW – Cayetano 230 kV line, subject to loss of Contra Costa – Las Positas 230 kV line	-	-	1	1
5	Midway – Vincent 500 kV line #1 or #2	1	-	4	-
6	Midway – Vincent 500 kV line #1, subject to loss of #2 line, or vice versa	69	-	28	-
7	Midway – Vincent 500 kV line #1 or #2, subject to loss of Midway – Whirlwind line	111	-	37	-
8	Path 26 (Northern – Southern California)	692	158	468	100
9	Path 26 north-to-south Operating Transfer Capability	5	-	8	-
10	Vincent 500/230 kV transformer #1	6	106	4	46
11	Villa Park – Lewis 230 kV line, subject to loss of Villa Park - Barre 230 kV line	2	2	-	-
12	Lewis – Barre 230 kV line, subject to loss of Villa Park – Barre 230 kV line	70	77	-	-
13	Barre - Ellis 230 kV line, subject to loss of Hassayampa – North Gila 500 kV lines	2	1	-	1
14	Litehipe – Hinson 230 kV line, subject to loss of La Fresno - Redondo 230 kV line	3	1	-	-
15	Julian Hinds – Mirage 230 kV	83	77	7	7
16	Kramer – Lugo 230 kV line #1 and #2	623	537	85	76
17	Inyo 115 kV phase shifter	769	676	760	744

#	Transmission Facilities	Year 2018		Year 2023	
		Before	After	Before	After
18	Control – Inyokern 115 kV line #1	-	-	34	35
19	Control – Tap710 115 kV line	-	-	458	430
20	Miguel 500/230 kV transformer #1, subject loss of transformer #2	-	2	1	-
21	SCIT limits	23	9	2	-

Figure 5.7-2 shows simulated power flow on Path 26. It can be seen that there is significant congestion from north to south.

Figure 5.7-2: Simulated Power Flow on Path 26  
(navy blue = hourly chronological flows; pink = duration exceedance curve)

Path 26 (Northern - Southern California) - simulated MW flow in 2023

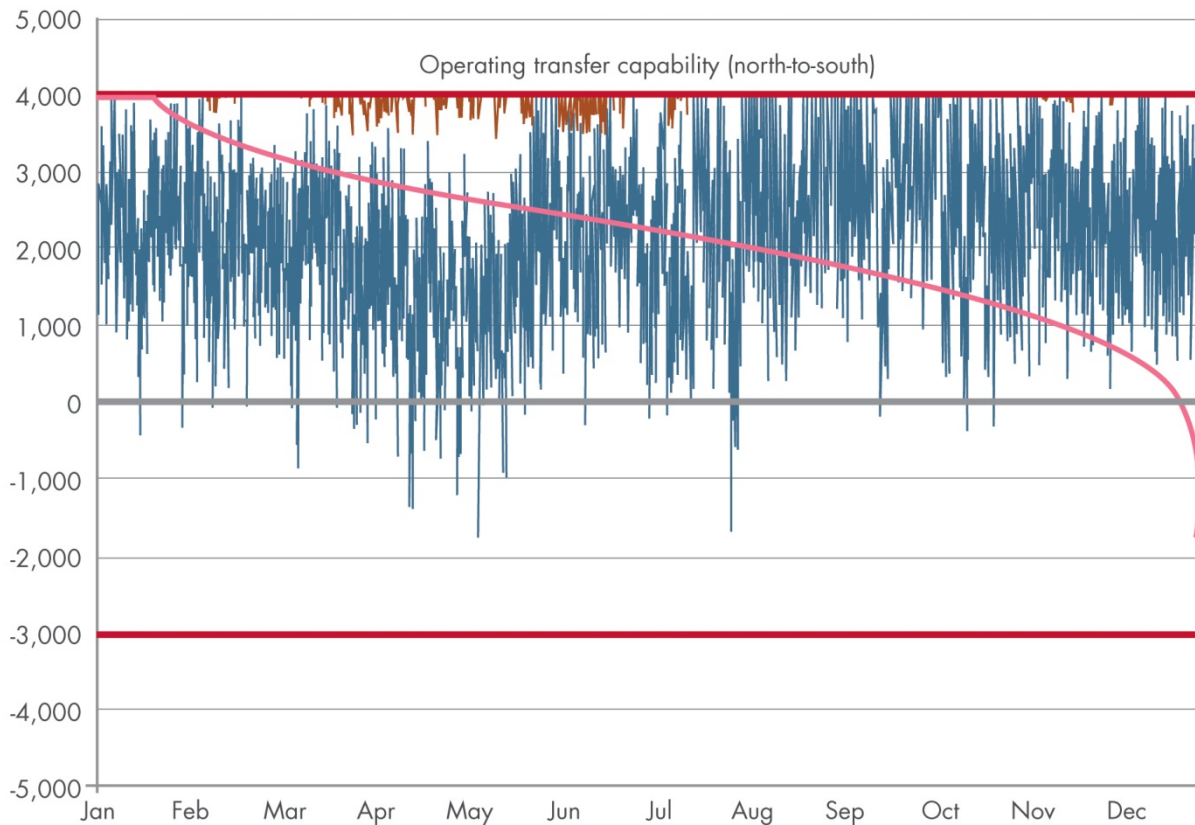

**5.7.1.2 Impacts to dispatch and LMP**

Figure 5.7-3 shows generation dispatch changes with adding the Midway – Vincent 500 kV line #4. It can be seen that relieving the Path 26 congestion will cause more efficient generation in northern California to displace less efficient generation in southern California.

Figure 5.7-3: Generation changes with addition of the Midway – Vincent 500 kV line #4

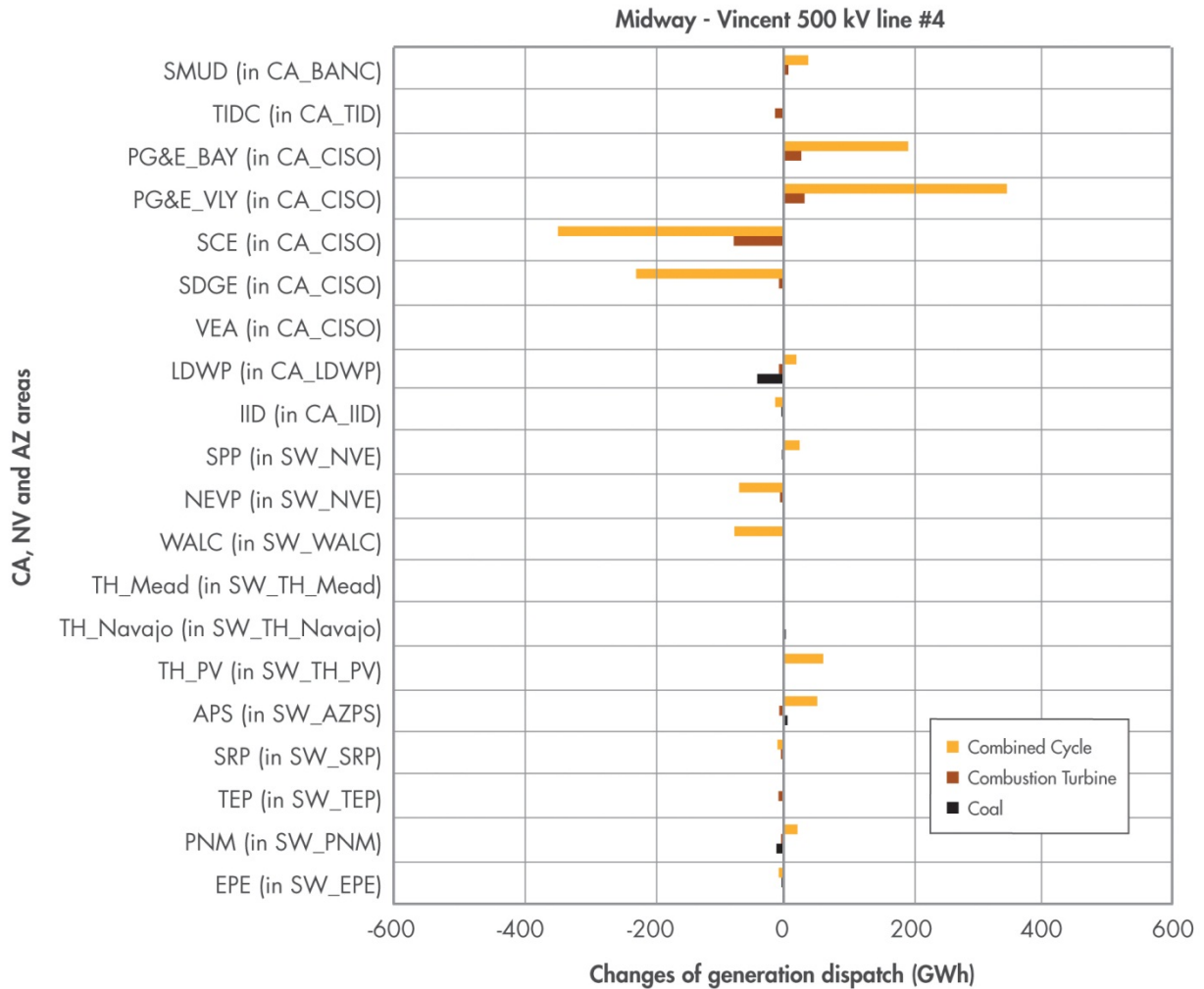
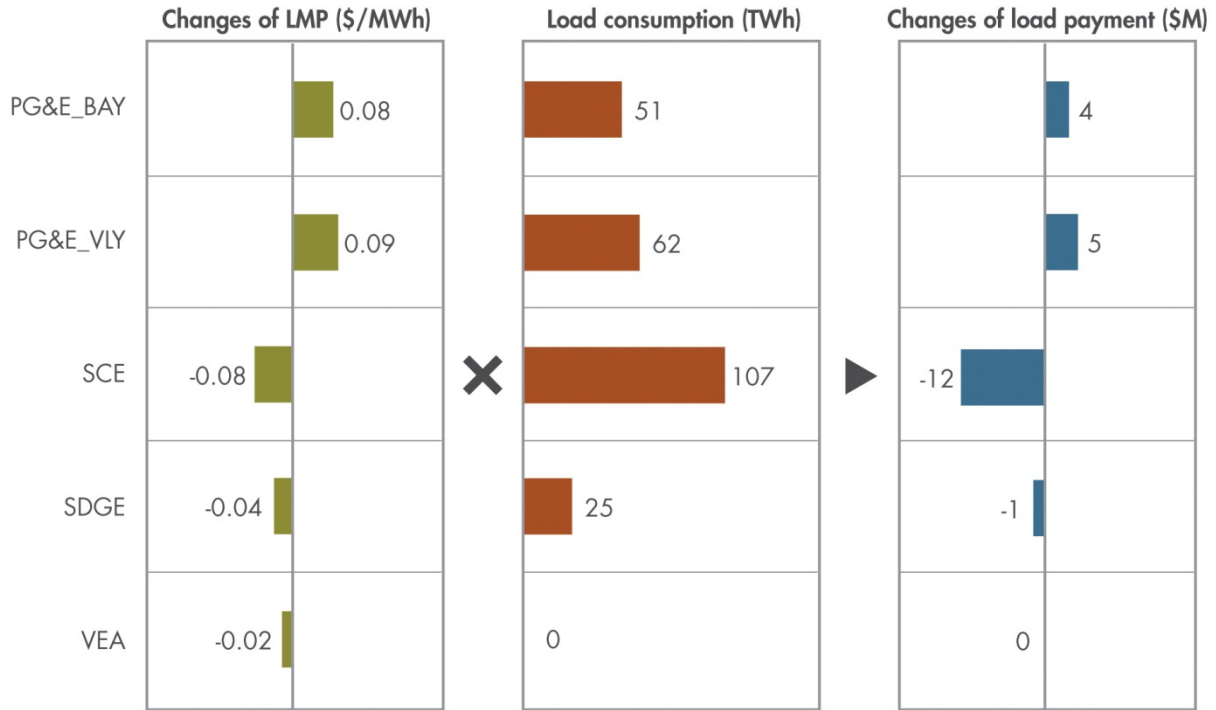

Figure 5.7-4 shows the resulting changes of LMP and load payments. It can be seen that after Path 26 north-to-south congestion is relieved, the northern California LMP increases while the southern California LMP decreases. The LMP changes lead to more load payment in northern California and less load payment in southern California. In terms of load payment, the biggest beneficiary is SCE.



Figure 5.7-4: LMP and load payment changes with addition of the Midway – Vincent 500 kV line #4



Simulation year 2023  
 The "Changes of LMP (\$/MWh)" is the difference of annual averages

**5.7.1.3 Production benefits**

Based on 8,760 hourly production simulations for the study years, yearly benefits are calculated as -\$4 million in 2018 and \$4 million in 2023, respectively. It is also attempted to estimate the losses reduction benefit outside the production simulation model using a traditional power flow calculation. In this case, the losses reduction benefit is considered negligible. Table 5.7-2 lists the quantified yearly production benefits.

Table 5.7-2: Yearly production benefits of building a new Midway – Vincent 500 kV line #4

Yearly production benefit			
Year	Production benefit calculated by production simulation	Losses reduction benefit estimated outside the production simulation model	Sum
2018	(\$4M)	-Negligible	(\$4M)
2023	\$4M		\$4M

#### 5.7.1.4 Capacity benefits

This project would not produce any system capacity benefits or local capacity benefits, because it would not increase import capability into the ISO balancing area and would not reduce local capacity needs.

Table 5.7-3: Yearly capacity benefits of building the Midway – Vincent 500 kV line #4

Yearly capacity benefit			
Year	System RA benefit	LCR benefit	Sum
-	Not applicable because the proposed line is within the ISO system	Not applicable because the proposed line does not enter a local capacity area	-

#### 5.7.1.5 Cost estimates

For the proposed Midway – Vincent 500 kV line #4, the capital cost is estimated as \$1,100 million; and the total cost (i.e. revenue requirement) is estimated at \$1,595 million using a “CC-to-RR multiplier” of 1.45. The cost estimates are listed in Table 5.7-4.

Table 5.7-4: Cost estimates for Midway – Vincent 500 kV line #4

Capital cost	Total cost (i.e. revenue requirement)
\$1,100M	\$1,595M

#### 5.7.1.6 Cost-benefit analysis

Based on yearly benefits determined in Sections 5.7.1.3 and 5.7.1.4, total benefit is calculated as present value of the benefits over the life of the project, assuming that it would go into operation in the year 2023. A cost-benefit analysis is provided in Table 5.6-5.

Table 5.7-5: Cost-benefit analysis of the proposed network upgrades for Path 26

Total benefit (\$M)	Total cost (\$M)	Net benefit (\$M)	Benefit-cost ratio
55	1,595	(1,540)	0.03

From the above results, it can be seen that although there is significant congestion on Path 26, economic benefit of the proposed Midway – Vincent 500 kV line #4 is insignificant. The insignificant benefit can be explained by and Figure 5.7-4.

Figure 5.7-4 shows the resulting changes of LMP and load payments. It can be seen that after Path 26 north-to-south congestion is relieved, the northern California LMP increases while the southern California LMP decreases. The LMP changes lead to more load payment in northern California and less load payment in southern California. In terms of load payment, the biggest beneficiary is SCE. This is because Path 26 lies in the middle of the ISO-controlled grid and that loads in the path's northern and southern systems are about the same. Relieving the congestion will cause the LMP to rise on one side and drop on the other side. As a result, the economic benefits in the northern and southern systems cancel each other.

#### **5.7.1.7 Recommendation**

Path 26 is an important link in the California transmission backbone. This economic planning study identified significant congestion on Path 26. Congestion on this path has ranked among the most congested in ISO economic planning studies for five consecutive years. The congestion is managed through the dispatch functions in the ISO market.

While the proposed Midway – Vincent 500 kV line reduces the congestion on Path 26, that does not translate into material economic benefits because of the economic benefits were largely cancelled out by the decreased cost in the south and increased cost in the north.

In absence of an economic justification, this transmission bottleneck will be handled by congestion management in market operations.

As Path 26 is a very important transmission interface, the ISO will continue to analyze the congestion issue in future studies.

### 5.7.2 Pacific Northwest – California (NWC)

This section describes the economic planning study of upgrading the existing Pacific DC Intertie.

Figure 5.7-5: System diagram and PDCI upgrade to increase rating from 3,220 MW to 3,780 MW

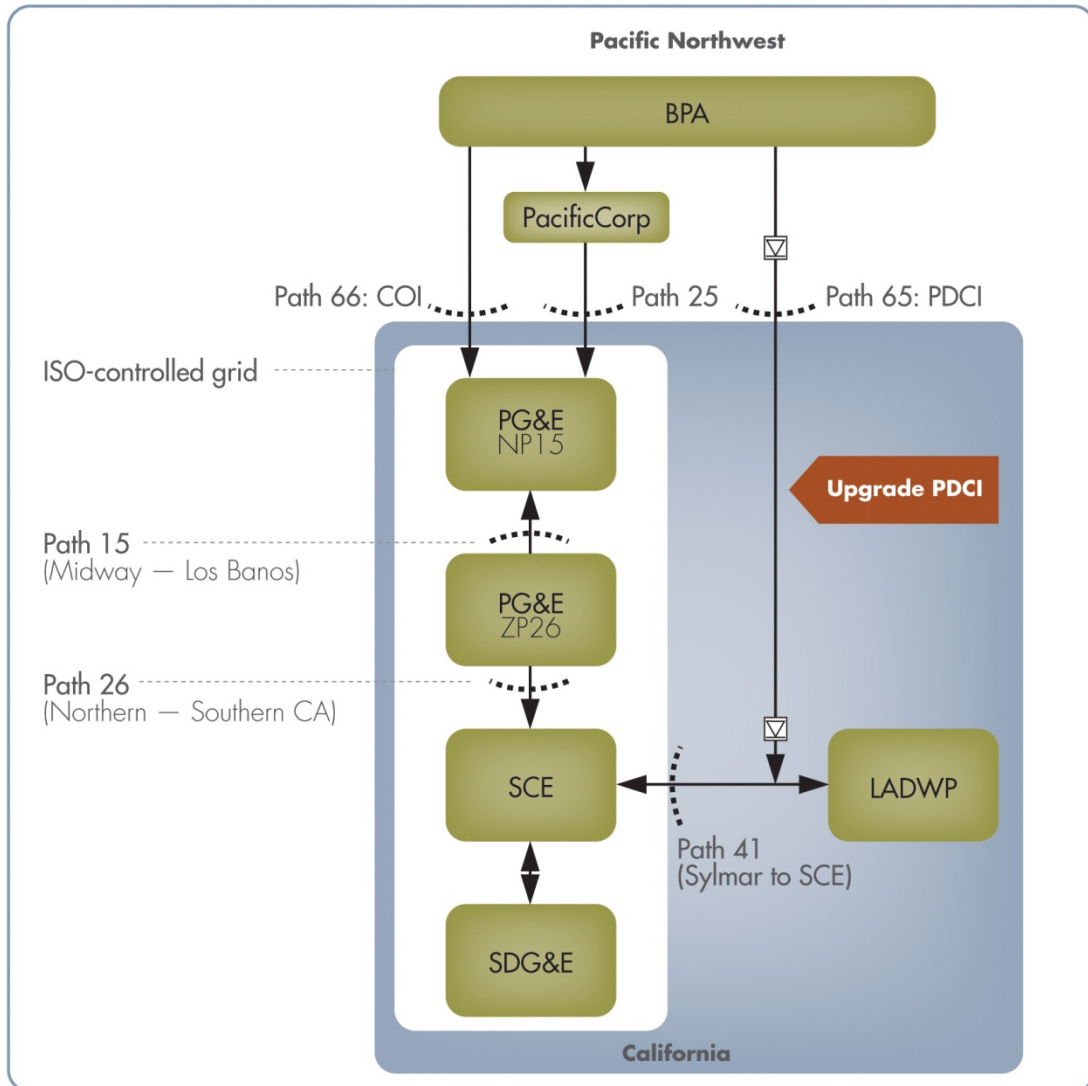

The present PDCI path rating is 3,100 MW. Currently, BPA’s PDCI Upgrade Project is in progress. This will increase the PDCI rating by 120 MW to 3,220 MW. This planning study analyzes a future potential network upgrade with an additional 500 MW increase to the PDCI rating.

### 5.7.2.1 Congestion analysis

Table 5.7-6 lists simulation results of congestion hours before and after the PDCI upgrade by 500 MW (from 3,220 to 3,780 MW) for the facilities identified as congested in Table 5.6-1.

Table 5.7-6: Congestion hours before and after PDCI upgrade by 500 MW

#	Transmission Facilities	Year 2018		Year 2023	
		Before	After	Before	After
1	Path 66 (COI) nomogram	3	1	-	-
2	Path 25 (PacifiCorp – PG&E 115 kV Interconnection)	488	477	651	640
3	Contra Costa Sub – Contra Costa 230 kV line	4	2	15	18
4	US Wind Power – JRW – Cayetano 230 kV line, subject to loss of Contra Costa – Las Positas 230 kV line	-	-	1	1
5	Midway – Vincent 500 kV line #1 or #2	1	-	4	3
6	Midway – Vincent 500 kV line #1, subject to loss of #2 line, or vice versa	69	59	28	31
7	Midway – Vincent 500 kV line #1 or #2, subject to loss of Midway – Whirlwind line	111	98	37	36
8	Path 26 (Northern – Southern California)	692	671	468	471
9	Path 26 north-to-south Operating Transfer Capability	5	3	8	6
10	Vincent 500/230 kV transformer #1	6	4	4	1
11	Villa Park – Lewis 230 kV line, subject to loss of Villa Park - Barre 230 kV line	2	-	-	-
12	Lewis – Barre 230 kV line, subject to loss of Villa Park – Barre 230 kV line	70	63	-	-
13	Barre - Ellis 230 kV line, subject to loss of Hassayampa – North Gila 500 kV lines	2	3	-	-
14	Litehipe – Hinson 230 kV line, subject to loss of La Fresno - Redondo 230 kV line	3	3	-	-
15	Julian Hinds – Mirage 230 kV	83	74	7	5
16	Kramer – Lugo 230 kV line #1 and #2	623	603	85	90
17	Inyo 115 kV phase shifter	769	756	760	772

#	Transmission Facilities	Year 2018		Year 2023	
		Before	After	Before	After
18	Control – Inyokern 115 kV line #1	-	-	34	32
19	Control – Tap710 115 kV line	-	-	458	447
20	Miguel 500/230 kV transformer #1, subject loss of transformer #2	-	-	1	-
21	SCIT limits	23	24	2	-

Figure 5.7–6 and Figure 5.7–7 show simulated power flow on Path 66 (California-Oregon Intertie) and Path 65 (Pacific DC Intertie), respectively. On the plots, chronological and duration curves are shown for the base case. Also, duration curves for high and low hydro scenarios are shown. The high (wet) and low (dry) scenarios are sensitivity cases constructed from historical hydro patterns in the WECC database. The high (wet) hydro scenario is based on year 2011 wet pattern in the Western Interconnection while the low (dry) hydro scenario is based on year 2001 dry pattern. The base case representing the medium hydro scenario is based on the year 2005 hydro pattern.

Figure 5.7-6: Simulated power flow on Path 66 (COI)  
(navy blue – hourly chronological flows; others – duration exceedance curve)

Path 66 (California-Oregon Intertie) - simulated MW flow in 2023

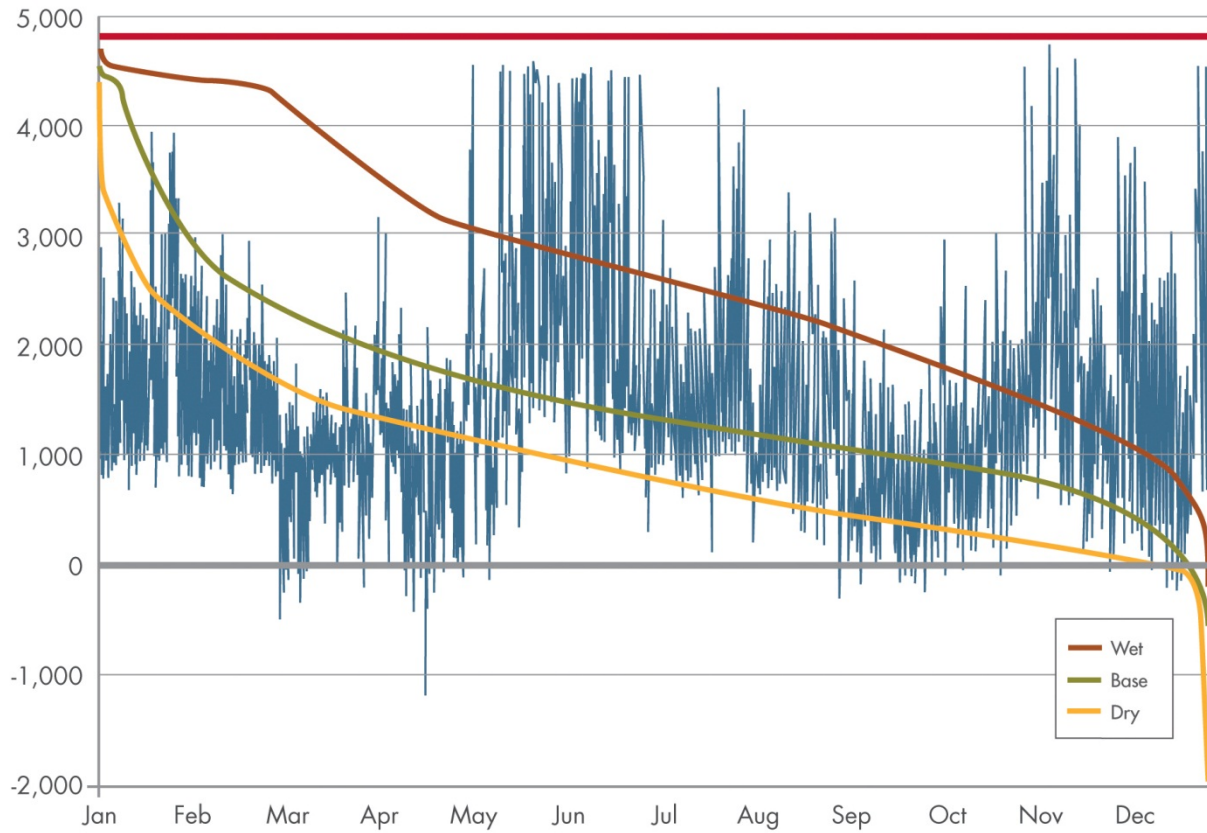
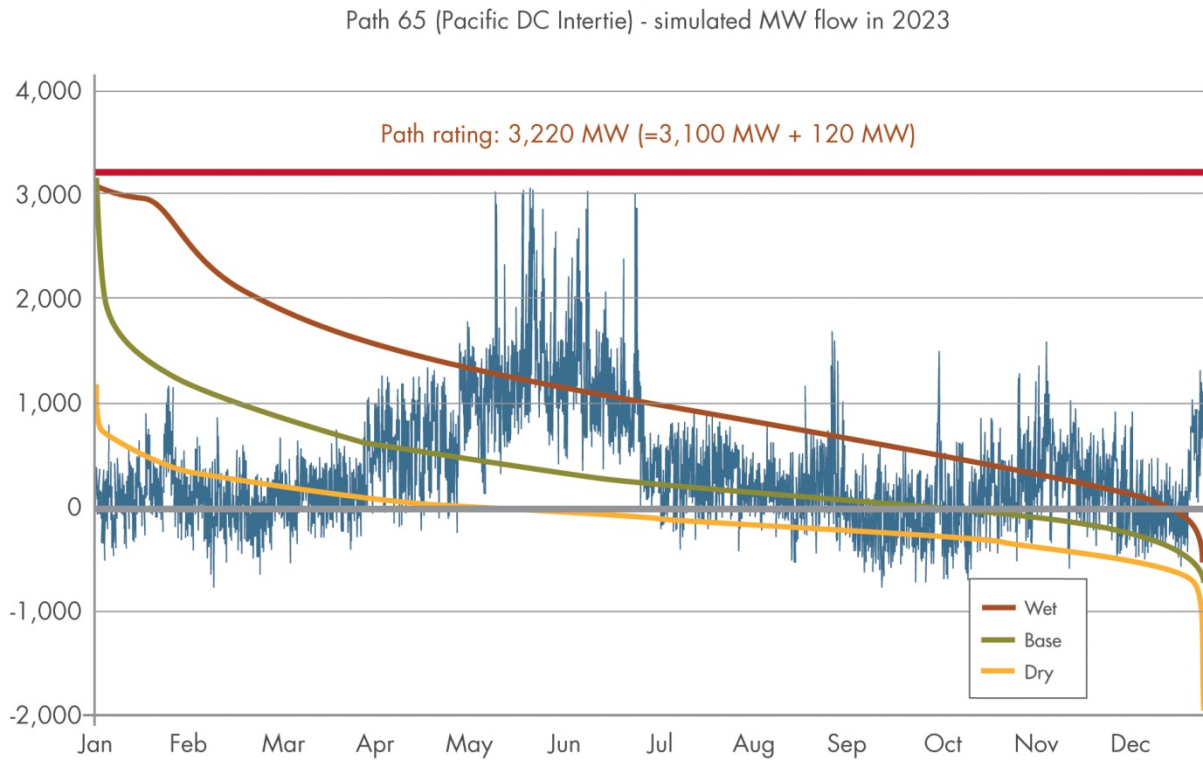

Figure 5.7-7: Simulated power flow on Path 65 (PDCI)  
 (navy blue = hourly chronological flows; others = duration exceedance curve)



The production simulation did not identify any congestion in this study area. However, and do show that the transmission paths are prone to congestion during high hydro output in the Pacific Northwest.



**5.7.2.2 Impacts to dispatch and LMP**

Figure 5.7-8 shows generation dispatch changes with the proposed PDCI upgrade. It can be seen that generation changes is more significant in LADWP area than the ISO-controlled area. This is understandable because the PDCI is more strongly tied to the LADWP system than the SCE system.

Figure 5.7-8: Generation changes with the proposed PDCI upgrade

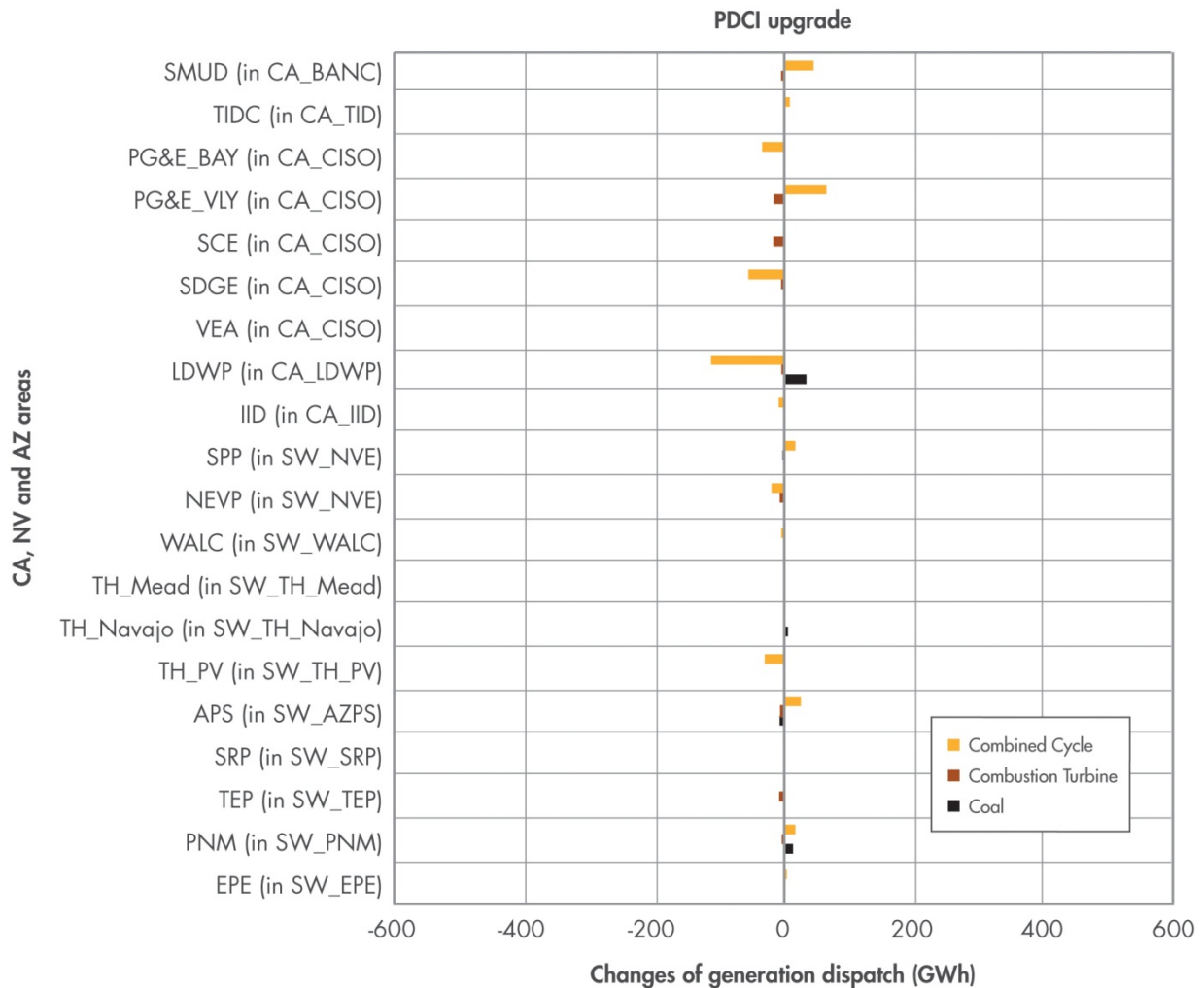
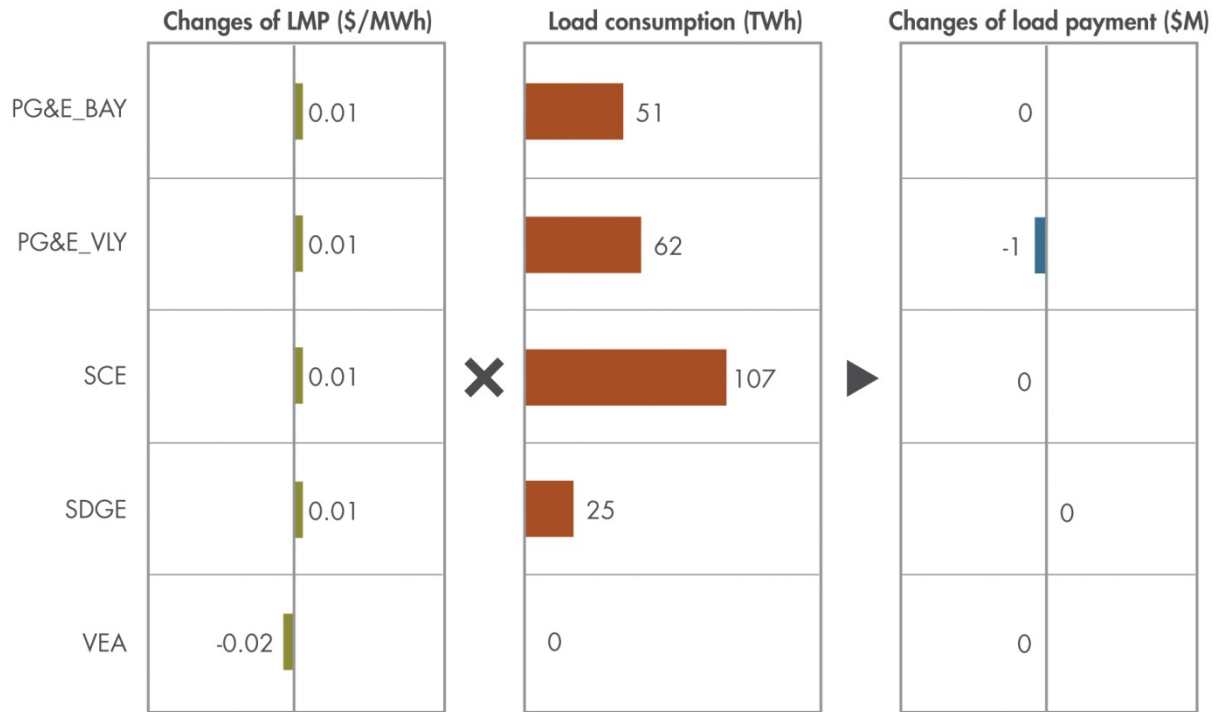

Figure 5.7-9 shows the resulting changes of LMP and load payments. It can be seen that with PDCI upgrade the impact to LMP in the ISO-controlled grid is limited. Based on the generation re-dispatch pattern, the upgrade mainly benefits LADWP while benefits to the ISO utilities are limited.

Figure 5.7-9: LMP and load payment changes with the proposed PDCI upgrade



Simulation year 2023  
 The "Changes of LMP (\$/MWh)" is the difference of annual averages

**5.7.2.3 Production benefits**

Based on 8,760 hourly production simulations for the study years, yearly benefits are calculated as \$7 million in 2018 and \$3 million in 2023, respectively. In addition, the losses reduction benefit was estimated outside the production simulation model using a traditional power flow calculation. In this case, the benefit was considered negligible. Table 5.7-7 lists quantified yearly production benefits.

Table 5.7-7: Yearly production benefits by upgrading the existing PDCI

Yearly production benefit			
Year	Production benefit calculated by production simulation	Losses reduction benefit estimated outside the production simulation model	Sum
2018	\$7M	negligible-	\$7M
2023	\$3M		\$3M

### 5.7.2.4 Capacity benefits

Because the PDCI southern terminus is outside the LCR boundary for the LA Basin, increasing the PDCI transfer capability would not provide any LCR benefits, as shown in Table 5.7-8.

Table 5.7-8: Yearly capacity benefits by upgrading the existing PDCI

Yearly capacity benefit
negligible

### 5.7.2.5 Cost estimates

For the proposed PDCI upgrade with a 500 MW rating increase, the capital cost is estimated as \$300 million, while the total cost (i.e., revenue requirement) is estimated at \$435 million using a “CC-to-RR multiplier” of 1.45. The cost estimates are listed in Table 5.7-9.

Table 5.7-9: Cost estimates for the proposed PDCI upgrade

Capital cost	Total cost (i.e. revenue requirement)
\$300M	\$435M

### 5.7.2.6 Cost-benefit analysis

Based on yearly benefits determined in Sections 5.7.2.3 and 5.7.2.4, total benefit is calculated in the present value on the assumed operation year. A cost-benefit analysis is provided in Table 5.7-10, assuming that the upgrade would go into service in the year 2018.

Table 5.7-10: Cost-benefit analysis of the proposed PDCI upgrade

Total benefit (\$M)	Total cost (\$M)	Net benefit (\$M)	Benefit-cost ratio
50	435	(385)	0.12

### 5.7.2.7 Recommendation

The study did not find an economic justification for the proposed PDCI upgrade.

Path 66 (COI) and Path 65 (PDCI) are important transmission interfaces for importing power for the Pacific Northwest that is abundant with hydro and wind resources. These paths will continue to be monitored in future transmission plan studies.

### 5.7.3 Harry Allen – Eldorado 500 kV line

This section describes the economic planning study of building a new Harry Allen – Eldorado 500 kV line.

#### 5.7.3.1 Congestion analysis

Table 5.7-11 lists simulation results of congestion hours before and after adding the proposed the Harry Allen – Eldorado 500 kV line, for the facilities that were identified as congested in Table 5.6-1.

Table 5.7-11: Congestion hours before and after adding the Harry Allen – Eldorado 500 kV line

#	Transmission Facilities	Year 2018		Year 2023	
		Before	After	Before	After
1	Path 66 (COI) nomogram	3	2	-	-
2	Path 25 (PacifiCorp – PG&E 115 kV Interconnection)	488	460	651	
3	Contra Costa Sub – Contra Costa 230 kV line	4	2	15	16
4	US Wind Power – JRW – Cayetano 230 kV line, subject to loss of Contra Costa – Las Positas 230 kV line	-	-	1	1
5	Midway – Vincent 500 kV line #1 or #2	1	-	4	3
6	Midway – Vincent 500 kV line #1, subject to loss of #2 line, or vice versa	69	45	28	24
7	Midway – Vincent 500 kV line #1 or #2, subject to loss of Midway – Whirlwind line	111	69	37	29
8	Path 26 (Northern – Southern California)	692	531	468	331
9	Path 26 north-to-south Operating Transfer Capability	5	3	8	2
10	Vincent 500/230 kV transformer #1	6	8	4	6
11	Villa Park – Lewis 230 kV line, subject to loss of Villa Park - Barre 230 kV line	2	3	-	-
12	Lewis – Barre 230 kV line, subject to loss of Villa Park – Barre 230 kV line (or loss of Serrano – Lewis 230 kV line)	70	76	-	-
13	Barre – Ellis 230 kV line, subject to loss of Hassayampa – North Gila 500 kV lines	2		-	-
14	Litehipe – Hinson 230 kV line, subject to loss of La Fresno - Redondo 230 kV line	3	3	-	-

#	Transmission Facilities	Year 2018		Year 2023	
		Before	After	Before	After
15	Julian Hinds – Mirage 230 kV	83	79	7	14
16	Kramer – Lugo 230 kV line #1 and #2	623	557	85	80
17	Inyo 115 kV phase shifter	769	675	760	508
18	Control – Inyokern 115 kV line #1	-	-	34	30
19	Control – Tap710 115 kV line	-	-	458	279
20	Miguel 500/230 kV transformer #1, subject loss of transformer #2	-	1	1	2
21	SCIT limits	23	-	2	1

### 5.7.3.2 Impacts to dispatch and LMP

Figure 5.7-10 shows generation dispatch changes with addition of the Harry Allen – Eldorado 500 kV line. It can be seen that building the Harry Allen – Eldorado 500 kV line will encourage using more efficient generation in NV Energy area; and the generation increase displaces more expensive generation in southern California.

Please note that in the figure, the “SDGE (in CA\_CISO)” shows an increase of generation. This generation is not in the San Diego area. Rather, this is a combined cycle plant located at the Nevada-California border near Eldorado 500 kV substation. In other words, this increase of generation is at the sending end (Las Vegas area in Nevada), not at the receiving end (San Diego area in California).

Figure 5.7-10: Generation changes with addition of the Harry Allen – Eldorado 500 kV line

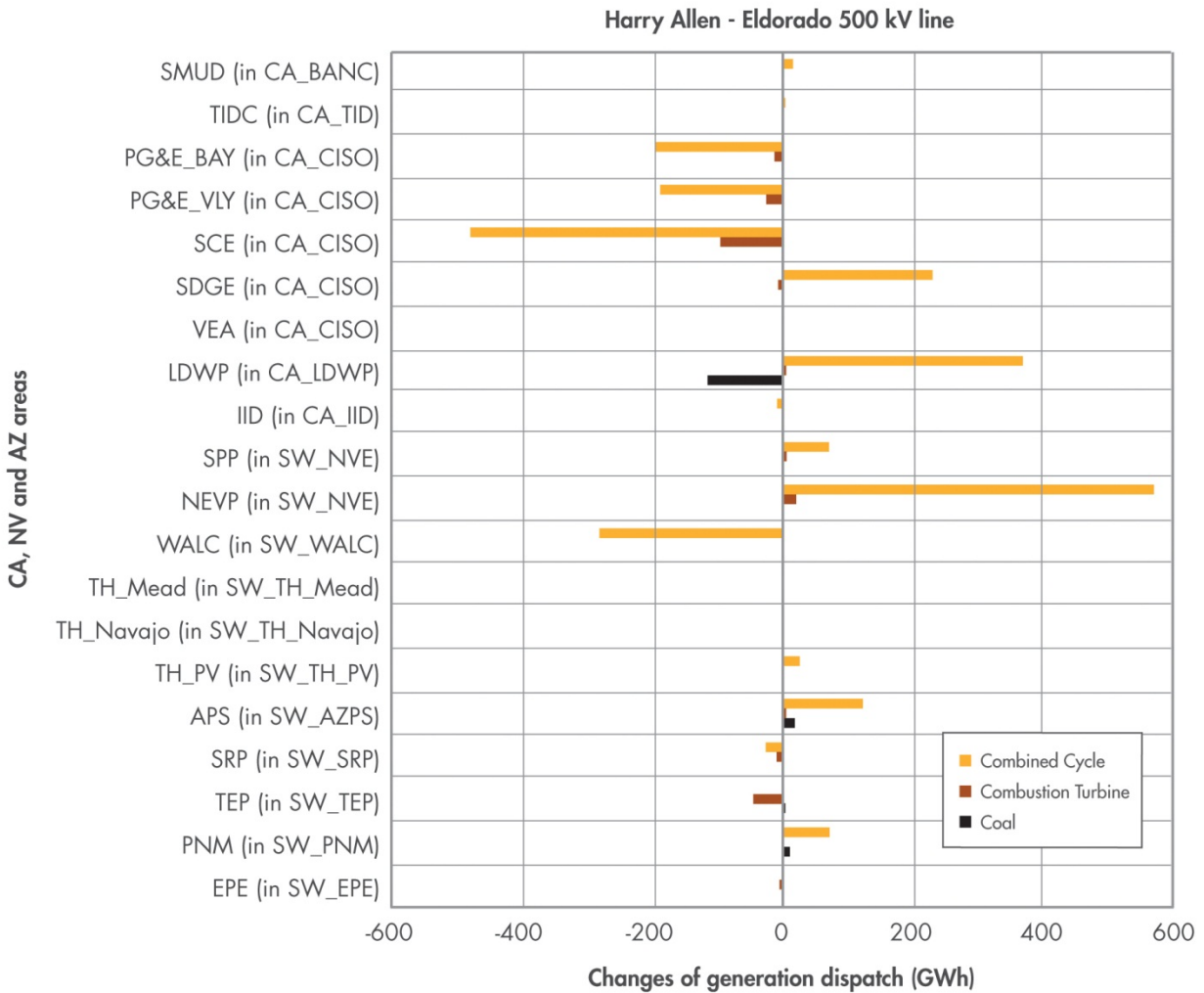
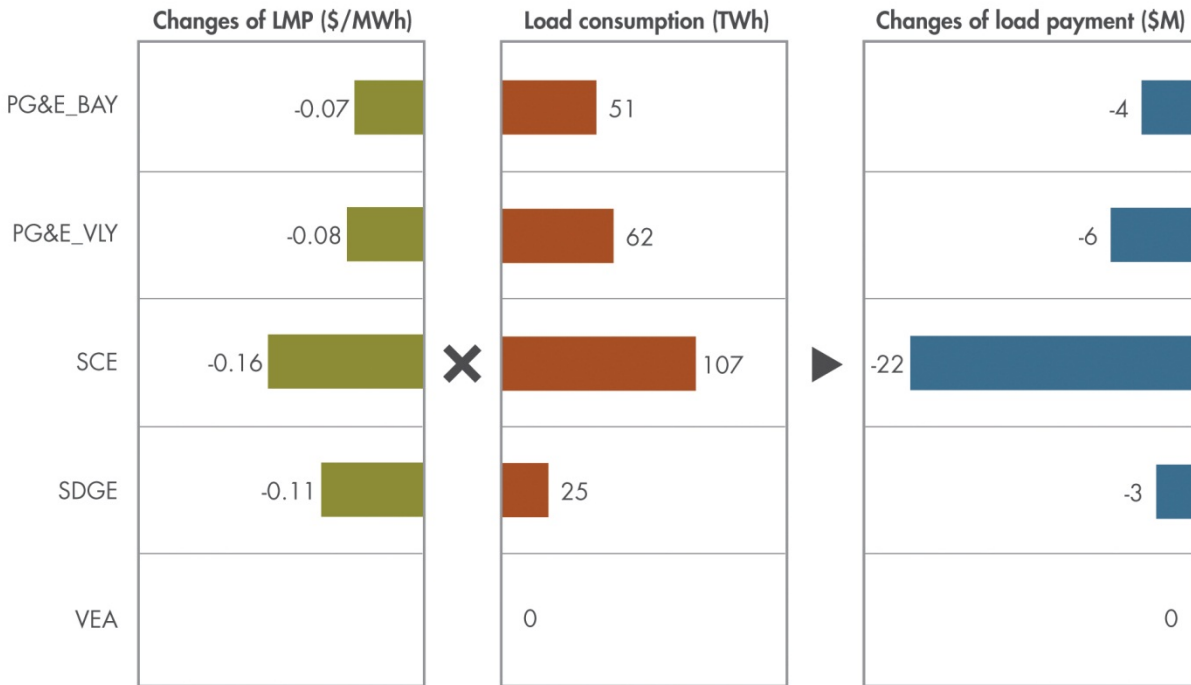

Figure 5.7-11 shows the resulting changes of LMP and load payments. It can be seen that with the addition of the Harry Allen – Eldorado 500 kV line, the LMP in the ISO-controlled grid decreases. The LMP decrease reduces load payment for the ISO ratepayers. It can be seen from the magnitudes of LMP decreases that the beneficiaries are SCE and SDG&E followed by PG&E. In terms of the dollar amount of load payment reduction, SCE is the biggest beneficiary.

Figure 5.7-11: LMP and load payment changes with addition of the Harry Allen – Eldorado 500 kV line



Simulation year 2023  
 The "Changes of LMP (\$/MWh)" is the difference of annual averages

**5.7.3.3 Production benefits**

Based on 8,760 hourly production simulations for the study years, yearly benefits to ISO customers are calculated as -\$3 million in 2018 and \$10 million in 2023, respectively. In addition, we estimated losses reduction benefit outside the production simulation model using a traditional power flow calculation. In this case, the losses reduction benefit is considered negligible. Table 5.7-12 lists quantified yearly production benefits.

Table 5.7-12: Yearly production benefits of building a new Harry Allen – Eldorado 500 kV line

Yearly production benefit			
Year	Production benefit calculated by production simulation	Losses reduction benefit estimated outside the production simulation model	Sum
2018	(\$3M)	-	(\$3M)
2023	\$10M	-	\$10M

### 5.7.3.4 Capacity benefits

Table 5.7-13 lists calculated yearly capacity benefits. The system RA benefits are calculated as 150 MW of incremental import capacity multiplied by capacity cost differences between California and Nevada/Arizona. LCR benefits are not applicable because this transmission line does affect any LCR areas.

The incremental import capacity increase is determined from the increase in West of River (WOR) transfer capability that is created by the addition of the Harry Allen – Eldorado 500 kV line project. The WECC path rating for WOR has been established as 11,200 MW under certain operating conditions. However, under summer peak operating conditions the transfer capability of this path is limited to a level that is below the WECC path rating due to contingency overloads on the Suncrest-Sycamore 230 kV lines and the Imperial Valley – ECO-Miguel 500 kV lines. These overloads are caused by imports from Arizona, Nevada, and IID and existing and new generation dispatch in southwestern California. Adding the Harry Allen – Eldorado 500 kV line to the system incrementally relieves these overloads and creates approximately 150 MW of incremental import capability.

The calculation of the Harry Allen – Eldorado planning capacity benefits are estimated below.

Table 5.7-13: Yearly capacity benefits of building a new Harry Allen – Eldorado 500 kV line

Year	System RA benefit
2018	0
2019	0
2020	15
2021	13
2022	12
2023	10
2024	8
2025	7
2026	7
2026-2069	7



### 5.7.3.5 Cost estimates

For the proposed Harry Allen – Eldorado 500 kV line, the capital cost is estimated as \$120 million while the total cost (revenue requirement) is estimated at \$174 million using a “CC-to-RR multiplier” of 1.45. The cost estimates are listed in Table 5.7-14.

Table 5.7-14: Cost estimates for the proposed Harry Allen – Eldorado 500 kV line

Capital cost	Total cost (i.e. revenue requirement)
\$120M	\$174M

### 5.7.3.6 Cost-benefit analysis

Based on yearly benefits determined in Sections 5.7.3.3 total benefit is calculated in the present value based on the assumed operation year. A cost-benefit analysis is provided in Table 5.7-15.

Table 5.7-15: Cost-benefit analysis of the proposed Harry Allen – Eldorado 500 kV line

Assumed operation year: 2020			
Total benefit (\$M)	Total cost (\$M)	Net benefit (\$M)	Benefit-cost ratio
240	174	66	1.38

### 5.7.3.7 Recommendation

Currently, there are transmission constraints between NV Energy and the ISO systems. The proposed Harry Allen – Eldorado 500 kV line is located between NV Energy and ISO-controlled grid and would increase transfer capability between these two systems.

At this point, the model has not adequately represented the Energy Imbalance Market between NV Energy and the ISO. Further, responding to a stakeholder comment in the transmission planning process, the ISO investigated the WECC production simulation model of a transmission facility outside of the ISO footprint with the owners of that facility. This investigation led to a correction of the Westwing-Mead 500 kV transmission line parameters by the owners of the transmission line. This correction is not reflected in the above results, and preliminary analysis suggests the correction may have a material reduction in benefits. Therefore, the current economic assessment is considered preliminary.

### 5.7.4 Delaney – Colorado River 500 kV line

This section describes the economic planning study of building a new Delaney – Colorado River 500 kV line.

#### 5.7.4.1 Congestion analysis

Table 5.7-16 lists simulation results of congestion hours before and after adding the proposed the Delaney – Colorado River 500 kV line for the facilities that were identified as congested in Table 5.6-1.

Table 5.7-16: Congestion hours before and after adding the Delaney – Colorado River 500 kV line

#	Transmission Facilities	Year 2018		Year 2023	
		Before	After	Before	After
1	Path 66 (COI) nomogram	3	1	-	-
2	Path 25 (PacifiCorp – PG&E 115 kV Interconnection)	488	510	651	660
3	Contra Costa Sub – Contra Costa 230 kV line	4	7	15	18
4	US Wind Power – JRW – Cayetano 230 kV line, subject to loss of Contra Costa – Las Positas 230 kV line	-	-	1	1
5	Midway – Vincent 500 kV line #1 or #2	1	-	4	3
6	Midway – Vincent 500 kV line #1, subject to loss of #2 line, or vice versa	69	61	28	32
7	Midway – Vincent 500 kV line #1 or #2, subject to loss of Midway – Whirlwind line	111	85	37	30
8	Path 26 (Northern – Southern California)	692	621	468	420
9	Path 26 north-to-south Operating Transfer Capability	5	1	8	7
10	Vincent 500/230 kV transformer #1	6	5	4	3
11	Villa Park – Lewis 230 kV line, subject to loss of Villa Park - Barre 230 kV line	2	5	-	-
12	Lewis – Barre 230 kV line, subject to loss of Villa Park – Barre 230 kV line	70	104	-	-
13	Barre - Ellis 230 kV line, subject to loss of Hassayampa – North Gila 500 kV lines	2	-	-	-

#	Transmission Facilities	Year 2018		Year 2023	
		Before	After	Before	After
14	Litehipe – Hinson 230 kV line, subject to loss of La Fresno - Redondo 230 kV line	3	5	-	-
15	Julian Hinds – Mirage 230 kV	83	2	7	-
16	Kramer – Lugo 230 kV line #1 and #2	623	584	85	77
17	Inyo 115 kV phase shifter	769	733	760	749
18	Control – Inyokern 115 kV line #1	-	-	34	35
19	Control – Tap710 115 kV line	-	-	458	464
20	Miguel 500/230 kV transformer #1, subject loss of transformer #2	-	-	1	-
21	SCIT limits	23	-	2	-

Figure 5.7-12 shows the topology of the interconnected system of Nevada, Arizona and Southern California. The figure is a simplified system diagram derived from with the proposed Delaney – Colorado River 500 kV line marked as “D-CR” explains the simulation results shown in Figure 5.7-13.

Figure 5.7-12: 500 kV transmission connections between Nevada/Arizona and Southern California ISO system

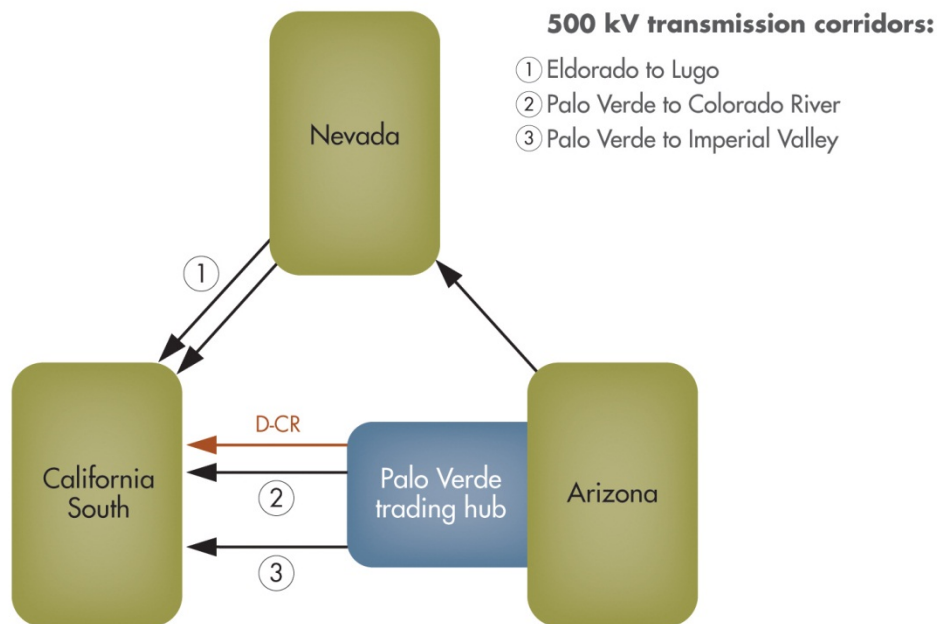

Figure 5.7-13 shows simulation results of energy transfer from Nevada to Southern California and from Arizona to California via 500 kV transmission lines. Each bar is a 365 day accumulation of energy for each hour. It shows the Southern California import is heavily distributed on the Nevada – California transmission corridor and that the Palo Verde – Colorado River transmission corridor carries less power. Even the North Gila – Imperial Valley transmission corridor carries more power than the Palo Verde – Colorado River corridor. Adding the new Palo Verde – Colorado River 500 kV line provides Southern California with more direct access to efficient generation at Palo Verde Trading Hub and APS system.

Figure 5.7-13: Energy transfer from NV and AZ to CA via 500 kV ties with addition of the Delaney – Colorado River 500 kV line

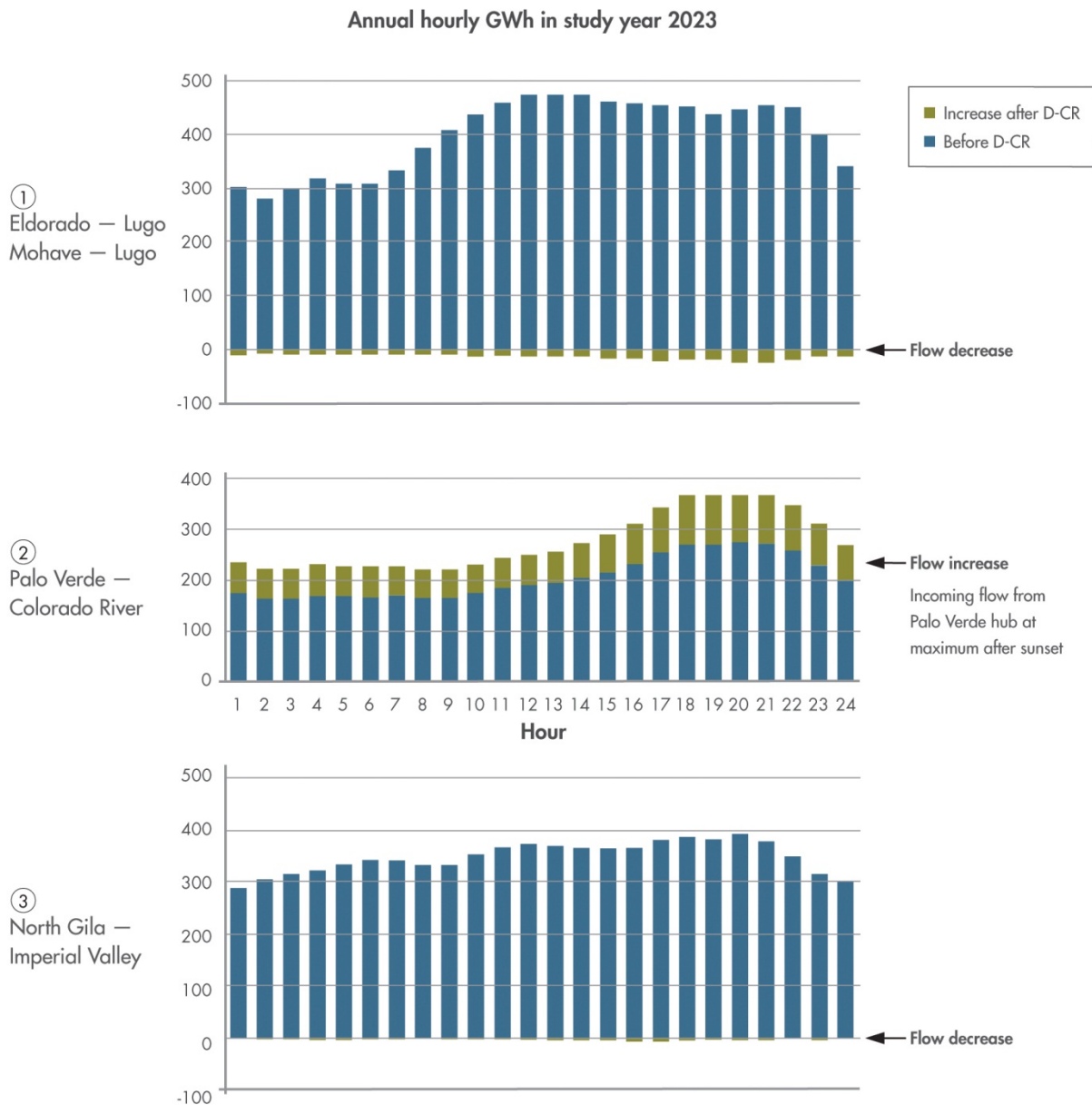
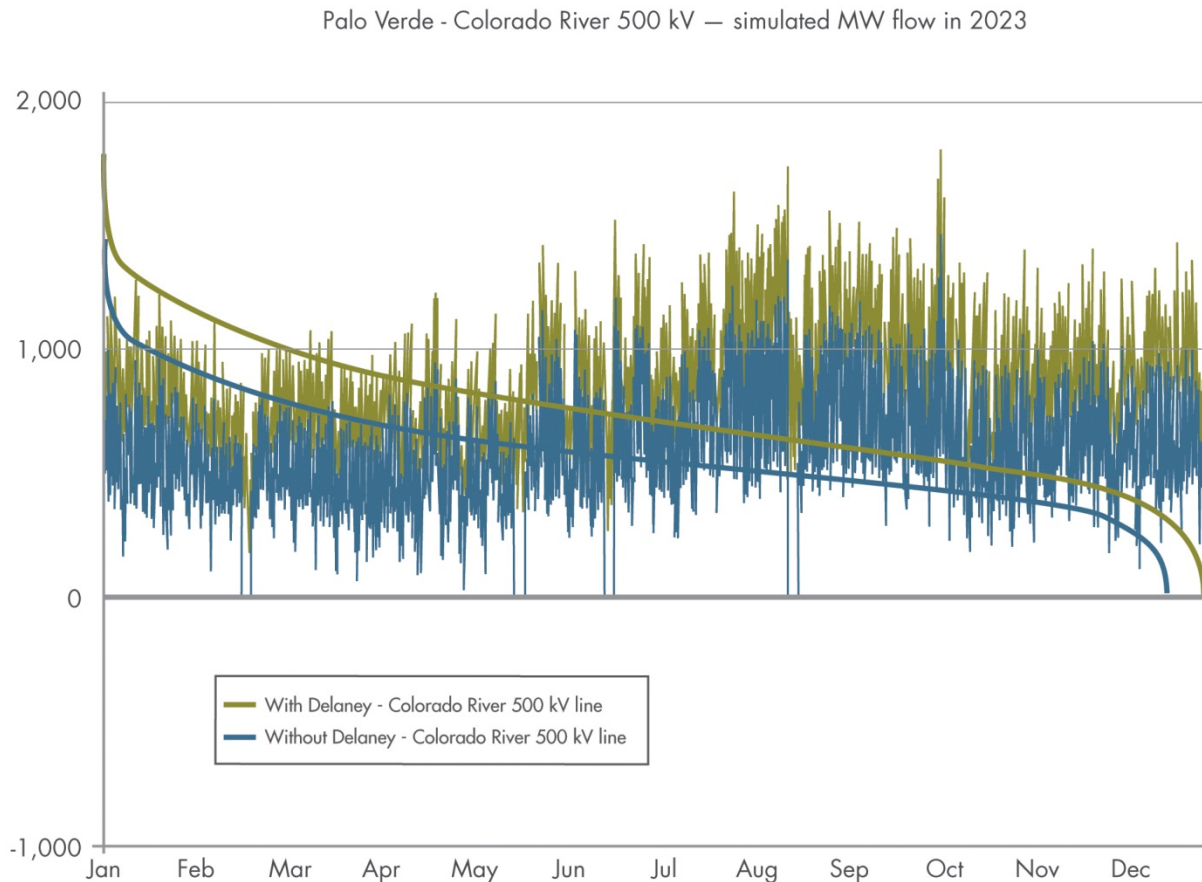

Figure 5.7-14 shows simulation results of 500 kV transmission flows from Palo Verde to Colorado River.

Figure 5.7-14: Line flows from Palo Verde to Colorado River with addition of the Delaney – Colorado River 500 kV line



The Delaney – Colorado River 500 kV line allows SCE area to:

1. Have more efficient access to the Palo Verde trading hub
2. Have uninterrupted access to the Palo Verde hub under L-1 conditions
3. Receive 30% more dispatched energy via this transmission corridor

#### 5.7.4.2 Impacts to dispatch and LMP

Figure 5.7-15 shows generation dispatch changes with addition of the Delaney – Colorado River 500 kV line. The line will facilitate more use of efficient generation at the line's sending end (the Palo Verde trading hub and APS area). Generation increase at Palo Verde and APS displaces more expensive generation at the receiving end (SCE, SDG&E and PG&E areas).

Figure 5.7-15: Generation changes with addition of the Delaney – Colorado River 500 kV line

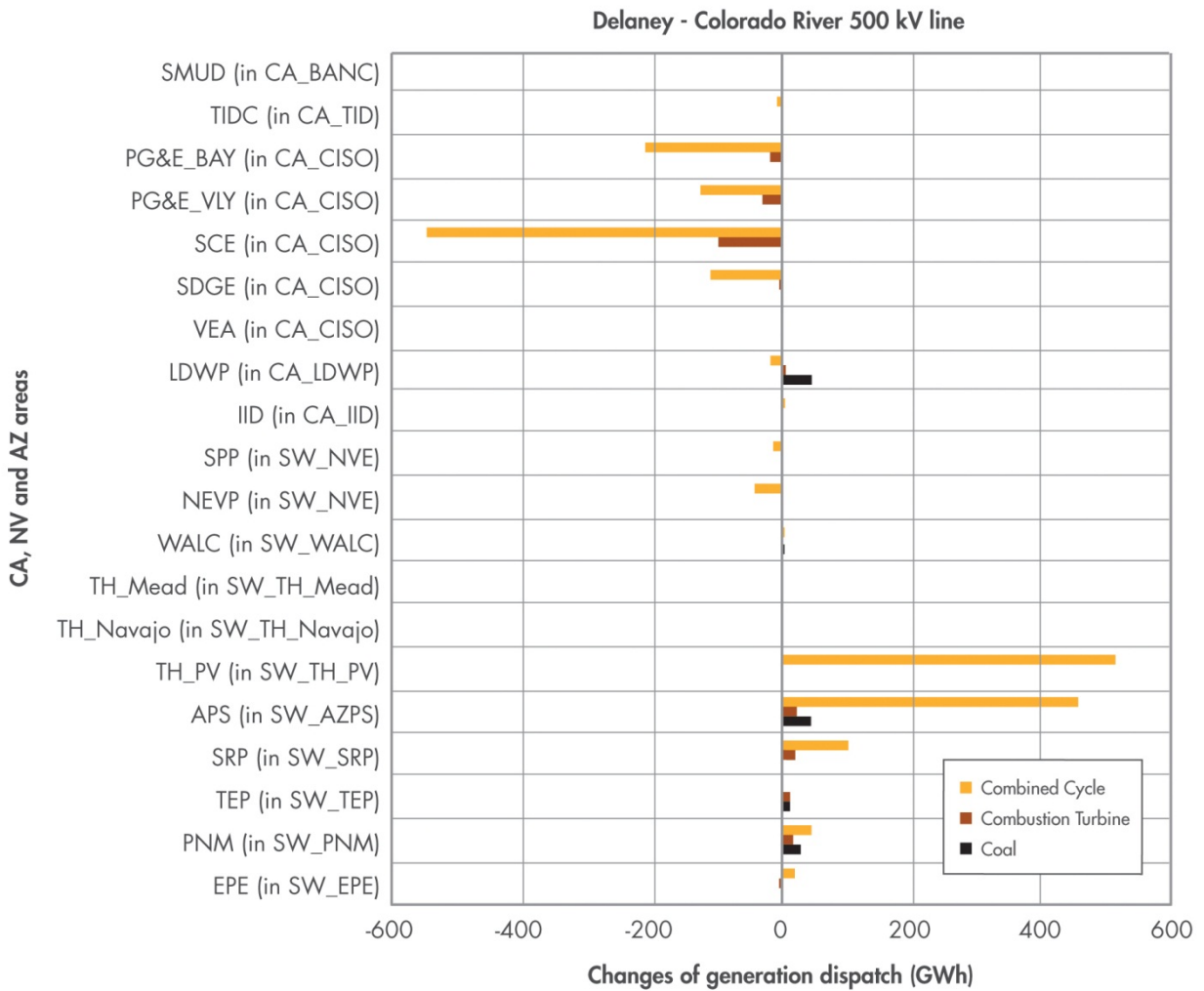
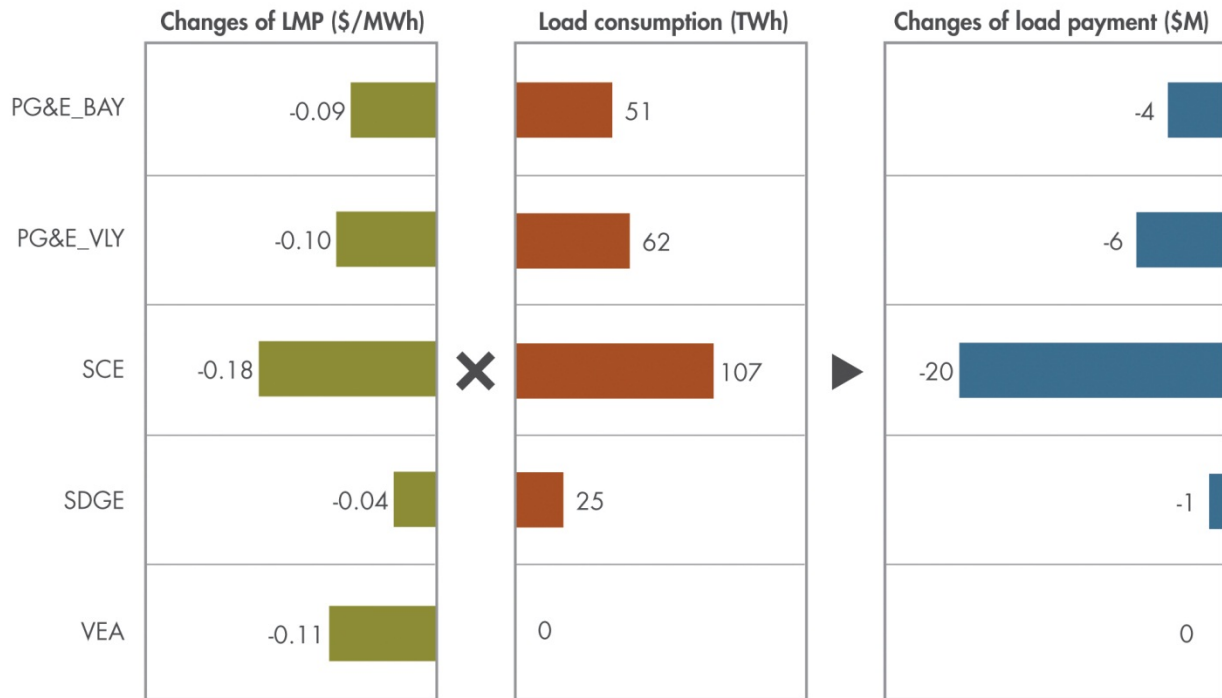

Figure 5.7-16 shows the resulting changes of LMP and load payments. It can be seen that with the addition of the Delaney – Colorado 500 kV line reduces LMP in the ISO-controlled grid. The LMP reduction leads to load payment reduction in the SCE, SDG&E, PG&E, and VEA areas and benefits to their ratepayers in total (ISO ratepayers). The SCE area sees the largest load payment reduction.

Figure 5.7-16: LMP and load payment changes with addition of the Delaney – Colorado River 500 kV line



Simulation year 2023  
 The "Changes of LMP (\$/MWh)" is the difference of annual averages

**5.7.4.3 Production benefits**

Based on 8,760 hourly production simulations for the study years, yearly ISO ratepayer benefits are calculated as \$26 million in 2018 and \$17 million in 2023, respectively. In addition, we estimated losses reduction benefit outside the production simulation model using a traditional power flow calculation. In this case, the losses reduction benefit is estimated as \$1 million per year. Table 5.7-17 lists quantified yearly production benefits.

Table 5.7-17: Yearly production benefits of building a new Delaney – Colorado River 500 kV line

Yearly production benefit			
Year	Production benefit calculated by production simulation	Losses reduction benefit estimated outside the production simulation model	Sum
2018	\$26M	\$1M	\$27M
2023	\$17M		\$18M

Table 5.7-18 provides a breakdown of yearly production benefits to ISO ratepayers computed by production simulation. The producer surplus is for load serving entity owned generation.

Table 5.7-18: Breakdown of yearly production benefits computed by production simulation

Year	Production benefit calculated by production simulation	Consumer benefit	Producer benefit	Transmission benefit
2018	\$25.6M	\$30.3M	(\$4.1M)	(\$0.7M)
2023	\$17.0M	\$21.7M	(\$3.4M)	(\$1.3M)

#### 5.7.4.4 Capacity benefits

The system RA benefits are calculated as 200 MW to 300 MW of incremental import capacity multiplied by capacity cost differences between California and Arizona. The incremental import capacity increase is determined from the increase in West of River (WOR) transfer capability that is created by the addition of the Delaney – Colorado River 500 kV line project. The WECC path rating for WOR is 11,200 MW under certain operating conditions. However, under summer peak operating conditions, the transfer capability of this path is limited to a level that is below the WECC path rating due to contingency overloads on the Suncrest – Sycamore 230 kV lines and the Imperial Valley – ECO – Miguel 500 kV lines. These overloads are caused by imports from Arizona, Nevada, and IID and existing and new generation dispatch in southwestern California. Adding the Delaney – Colorado River 500 kV line to the system incrementally relieves these overloads and allows approximately 200 MW to 300 MW of incremental import capacity. The variation from 200 MW to 300 MW is due to the uncertainty in the Sycamore – Suncrest 230 kV line ratings, and the assumed operation of the Imperial Valley to CFE flow control device. The 300 MW increase is the result when the Sycamore – Suncrest line is the limiting facility and the 200 MW increase is the result when the ECO-Miguel 500 kV line is the limiting facility due to a higher Sycamore – Suncrest line rating or higher flows on the Imperial Valley to CFE flow control device are assumed.

The Delaney – Colorado River (D-CR) planning capacity benefits calculation is based on the following primary assumptions, which are further explained below:

1. California will be resource deficit by 2020;
2. Arizona will resource deficit by 2025;
3. Arizona peaking units can be built and operated at a lower cost than California peaking units; and
4. The incremental capacity available with the addition of the D-CR line is approximately 200 MW to 300 MW available starting in 2020.



### **California Resource Deficiency**

The ISO conducted a system operational flexibility modeling study using the Standardized Planning Assumptions and Scenarios as determined in the CPUC Dec 24, 2012 decision (12-03-014).<sup>40</sup> The operational flexibility study was performed using a Plexos production cost simulation model and was performed on four scenarios for the year 2022: 1) base scenario, 2) replicating TPP scenario, 3) high DG-DSM scenario, and 4) base scenario with SONGS. The base scenarios showed a 1,000 to 3,000 MW upward ancillary services and load-following shortage while the replicating TPP scenario showed a 4,000 MW to 5,000 MW shortage<sup>41</sup>. Adjusting these shortage amounts down by 800 MW based on the load growth from 2020 to 2022 results in a resource capacity shortage in 2020.

### **Direct and Indirect Benefits**

Planning capacity benefits are frequently separated into two categories, which are referred to as “direct” and “indirect” benefits. Only the direct benefits are calculated in this document and are based on the assumption that California is able to buy lower cost capacity in Arizona — either due to Arizona’s capacity surplus or from a lower cost CT.

The indirect benefits result from a more competitive California marketplace. Increased competition generally causes market prices to be lower (the market prices are closer to marginal costs). In other words, increased competition reduces the opportunity for market power and impacts the entire spot capacity market. These indirect benefits can be very significant.

### **Arizona Resource Deficiency**

The WECC Desert Southwest sub-region is forecast to be resource surplus until 2025.<sup>42</sup> The NERC “2012 Long-Term Reliability Assessment” projects an anticipated planning reserve margin of 29.1 percent in 2022 (the last year of the NERC assessment).<sup>43</sup> If the net summer system load continued to grow at annual average 1.53 percent, and if there were no significant generation retirements, the projected planning reserve margin in 2025 would be 23.3 percent as summarized in Table 5.7-19 below:<sup>44</sup> If 2,760 MW were retired without any significant resource additions (supply- or demand-side), the Desert Southwest would be in resource balance in 2025 from a planning reserve margin perspective.

---

<sup>40</sup> California Independent System Operator, “Review of Scenario Assumptions and Deterministic Results”, CPUC LTPP Track 2 Workshop, August 26 2013, Dr. Shucheng Liu, Principal in Market Development, page 29, “Upward Ancillary Services and load following shortages”.

<sup>41</sup> The ISO updated DR assumptions in the model after the August 26, 2013 workshop and shared the new results with an industry advisory team. The new results show a 2709 MW and 5378 MW shortage for the base scenario and replicating TPP scenario respectively.

<sup>42</sup> Since WECC does not prepare a summary of individual states but rather uses WECC subregions; the Desert Southwest subregion is considered to provide an accurate perspective of Arizona’s resources and loads.

<sup>43</sup> NERC LTRA, “WECC Subregional Tables”, Planning Reserve Margins WECC DSW (Desert Southwest), p. 255/355.

<sup>44</sup> NERC LTRA, “Demand Outlook WECC-DSW”, p. 257/355.

Table 5.7-19: Summary of DSW planning reserve margins

Parameter	Units	2022 (NERC Projected)	2025 (no retirements)	2025 (2750 MW retired)
Net Total Capacity	MW	40,795	40,795	38,036
Net Internal Demand	MW	31,602	33,075	33,075
Planning Reserve Margin	Percent	29.1%	23.3%	15.0

Because the Desert Southwest is likely to have some demand- or supply-side retirements, the assumption that the Desert Southwest will not be in surplus by the year 2025 is reasonable.

### **Relative Net Cost of CA and AZ Capacity**

The cost of capacity from peaking units in California is forecast to be \$41/kw-year more than the comparable annual cost in Arizona in 2012 dollars. The cost of capacity is defined as the CT annual net fixed costs (capital levelized revenue requirement, plus fixed O&M, minus the net energy and AS value in the marketplace).

For purposes of this analysis, the simplifying assumption is made that the costs (CT capital and fixed O&M), as well as the market prices escalate at inflation (a real escalation rate of 0 percent). This assumption applies to costs and prices in both California and Arizona. CT costs could escalate at a rate higher than inflation, but so could market prices and thus largely offsetting each other in terms of the benefit-cost-ratio.<sup>45</sup>

It is also assumed that by the year 2020, the future peaking plants in California and Arizona will be flexible aero-derivative units instead of large industrial frame units.<sup>46</sup> These flexible units will be needed as more intermittent renewable generation is added to the system. The California industrial frame-type CT capital and fixed O&M cost is derived from the ISO 2012 [Annual Report on Market Issues and Performance](#) and is \$155/kw-yr and \$35/kw-year, respectively, in 2012 dollars.<sup>47</sup> The California industrial frame CT capital cost then was increased by 44 percent to represent an aero-derivative combustion turbine cost.<sup>48</sup> This resulting annual capital cost is then increased by fixed O&M, reduced for energy and AS net revenue and adjusted for summer

<sup>45</sup> The CT costs and the market prices are correlated. If the CT or CC costs increase at a rate greater than inflation, the market will reflect these price increases in the energy and AS prices. This is not a perfect correlation, but they are expected to be tightly linked.

<sup>46</sup> CEC "Status of all Projects", [www.energy.ca.gov/sitingcases/all-projects.html](http://www.energy.ca.gov/sitingcases/all-projects.html).

<sup>47</sup> ISO "2012 Annual Report on Market Issues and Performance", Department of Market Monitoring, Table 1.9 "Assumptions for a typical new combustion turbine

<sup>48</sup> "Cost and Performance Review of Generation Technologies", prepared for WECC by E3, October 9 2012, Table 37, p. 69. The on line total capital cost of aero-derivative and frame CTs are \$1,150/kw and \$850/kw, respectfully, a 44 percent increase.

peak derate. The resulting net cost of California capacity when resource deficit is \$208/kw-year in 2012 dollars. This information is summarized in Table 5.7-20.

Table 5.7-20: Derivation of CA net capacity costs in 2012 \$

<b>Parameter</b>	<b>Value</b>	<b>Units</b>	<b>Source / Notes</b>
CA resource deficit year	2020	Year	2012 NERC LTRA
CA industrial capital cost	\$155	\$/kw-yr	2012 ISO Annual Report on Market Issues and Performance
CA aero/industrial increase	44%	Percent	WECC Generation Costs
CA aero capital cost	\$223	\$/kw-yr	Product of capital cost and aero increase
CA CT fixed O&M	\$35	\$/kw-yr	2012 ISO Annual Report on Market Issues and Performance
CA SP15 energy/AS rev.	\$60	\$/kw-yr	2012 ISO Annual Report on Market Issues and Performance
CA aero annual fixed costs	\$198	\$/kw-yr	Capital plus FOM minus net rev.
Summer peak-hour derate	5%	Percent	Assumption
CA aero net annual fixed cost	\$208	\$/kw-yr	Aero annual cost divided by 95% (i.e. summer peak derate)

Arizona's capacity cost (when resource deficit in 2025 and later) is based on the same approach as California. A summary of this calculation is contained in Table 5.7-21 below:

Table 5.7-21: Derivation of AZ net capacity costs in 2012 \$

Parameter	Value	Units	Source / Notes
AZ resource deficit year	2025	Year	2012 NERC LTRA
AZ aero total fixed costs	\$210	\$/kw-yr	WECC Generation Costs
AZ energy / AS rev.	\$54	\$/kw-yr	Assumption (90% of SP15)
AZ net aero fixed costs	\$156	\$/kw-yr	before derate
Summer peak-hour derate	5%	Percent	assumption (same as CA)
AZ net aero fixed costs	\$164	\$/kw-yr	Aero annual cost divided by 95% (i.e. summer peak derate)

In a 2012 WECC document, CT capital and fixed costs are compared by state and province. The report states that the Arizona CT capital and fixed O&M costs are estimated to be 81 percent and 86 percent of the California costs, respectively.<sup>49</sup>

The sum of the Arizona capital and fixed O&M costs are derived by applying these percentages to the California costs to ensure a consistent basis for cost comparisons. The total CT capital and fixed O&M costs are calculated to be \$210/kw-year. This cost is decreased by the assumed Arizona energy/AS revenue<sup>50</sup> and increased due to the summer peak derating of 5 percent. The resulting net cost of Arizona new resource capacity is \$164/kw-yr in 2012 \$, or \$44/kw-year less than California capacity.

The Desert Southwest is not projected to become resource deficit until 2025. Prior to that time the capacity market prices there would prevail for the incremental capacity purchases over the D-CR line. There is a lack of public information on the current Arizona spot capacity price. It is assumed that \$5/kw-month for the four summer months (June – September) or \$20/kw-year in 2012 (2012 \$) is a reasonable current market price estimate. The assumed market price for 2012 is then linearly increased each year to the net cost of an Arizona aero CT in 2025. These annual estimates are summarized in Table 5.7-22 as well as the computed annual benefit.

<sup>49</sup> “Cost and Performance Review of Generation Technologies – Recommendations for WECC 10- and 20-Year Study Process”, WECC, Table 40, Technology-regional cost multipliers (technology-specific multipliers apply to capital costs; fixed O&M multiplier applies to fixed O&M for all technologies, p. 75.

<sup>50</sup> A comparison of Palo Verde to Inland hourly energy prices for the period of July 5-31, 2013 resulted in a 9.3 percent reduction in energy prices in Arizona. This figure was rounded to 10 percent and used as the energy / AS differential between California and Arizona.

Table 5.7-22: Annual capacity benefit (2012 \$) based on 200 MW Increase in WOR

Year <sup>51</sup>	AZ Market Price (\$/kw-yr) <sup>52</sup>	AZ CT Cost (\$/kw-yr)	SP15 CT Cost (\$/kw-yr)	CAISO Capacity Benefit (\$/kw-yr)	CAISO Capacity Benefit (mil. \$)
2012	\$20				
2013	\$31				
2014	\$42				
2015	\$53				
2016	\$64				
2017	\$76				
2018	\$87				
2019	\$98				
2020	\$109		\$208	\$99	\$20
2021	\$120		\$208	\$88	\$18
2022	\$131		\$208	\$77	\$15
2023	\$142		\$208	\$66	\$13
2024	\$153		\$208	\$55	\$11
2025	\$164	\$164	\$208	\$44	\$9
2026		\$164	\$208	\$44	\$9
2027-2069		\$164	\$208	\$44	\$9

Although the D-CR transmission upgrade is assumed to have a 50-year economic life, only the first eight years of capacity benefits are shown in this table. The annual capacity value is \$9 million per year in 2012 dollars from 2025 through 2069, assuming that the CT costs and market

<sup>51</sup> This economic study originated in 2012. Hence, the first year for projected market prices is 2012 and not a later year.

<sup>52</sup> Arizona market prices are interpolated between 2012 and 2025 when the Arizona market price is equivalent to the annual CT costs.

prices have a zero real escalation rate. The levelized ISO capacity benefit is \$11 million per year in 2012 dollars.<sup>53</sup>

Table 5.7-23: Yearly capacity benefits of building a new Delaney – Colorado River 500 kV line

Year	System RA benefit	System RA benefit
	200 MW	300 MW
2018	0	0
2019	0	0
2020	\$20M	\$30M
2021	\$18M	\$26M
2022	\$15M	\$23M
2023	\$13M	\$20M
2024	\$11M	\$16M
2025	\$9M	\$13M

### **Other Benefits**

In addition to the quantified economic benefits, the Delaney – Colorado River 500 kV line provides incremental reliability benefits as well. As shown in Chapter 4, the common corridor outage of the Lugo – Mohave and Lugo – Eldorado 500 kV lines results in overloads on the Lugo –Victorville 500 kV and Marketplace – Adelanto 500 kV lines. The addition of the Delaney – Colorado-River 500 kV line would mitigate the overload on the Marketplace – Adelanto 500 kV line and would incrementally reduce the loading on the Victorville – Lugo 500 kV line by about 8 percent. Although this common corridor outage has an exception from WECC and is considered a Category D contingency, the impacts of the outage on neighboring systems should not be allowed to grow unbounded. Therefore, a safety net generation dropping scheme is being implemented that will mitigate the impacts of the highest impact new generation, but Delaney – Colorado River can incrementally mitigate the impacts of higher contingency flows on neighboring systems caused by the development of generation in southeastern California and the retirement of generation in southwestern California.

The above capacity analysis is based on the conservative assumption that the capacity benefits are achieved through generation connected to transmission systems outside of the ISO controlled grid. However recent initiatives have created the opportunity for new generation to

<sup>53</sup> The levelized cost is the product of the present value of annual values (benefits or costs) multiplied by the appropriate capital recovery factor.

connect to the Hassayampa 500 kV bus and still be within the ISO BAA. In addition, the Delaney-Colorado River transmission line would be expected to create the opportunity for new generation to connect to Delaney 500 kV bus and still be within the ISO BAA. Generation inside the ISO BAA and connected to the ISO Controlled Grid has seamless access to the ISO transmission, and studies of capacity benefits for such generation would be based on the ISO's generation interconnection deliverability methodology which is designed for generation inside the ISO BAA and connected to the ISO Controlled Grid. Quantifying the capacity benefits of the Delaney-Colorado River 500 kV line utilizing the ISO's generation interconnection deliverability methodology based on the assumption that new Arizona generation is connected to the ISO Controlled Grid would result in capacity benefits higher than noted above.

Delaney-Colorado 500 kV line also provides policy benefits, as it can help improve the deliverability from the Imperial Valley renewable energy zone, as discussed in Section 4.3. These benefits were quantified based on the ISO's generation interconnection deliverability methodology. Utilizing the benefits of the Delaney-Colorado River line to increase deliverability from the Imperial Valley zone may result in trading off to some extent the capacity benefits quantified in this analysis. In addition, this use would presumably be considered of higher value for that to occur, which would therefore result in a higher overall benefit than attributed through the analysis examining conventional resource alternatives.

#### 5.7.4.5 Cost estimates

For the proposed Delaney – Colorado River 500 kV line, the capital cost is estimated as \$325 million in 2012 dollars. The total cost (revenue requirement) is estimated at \$469 million to \$560 million using financial calculations based on assumptions described in Section 5.5 and for sensitivity purposes, with a 10% return on equity, 5% discount rate, and Arizona state tax rate. The cost estimates are listed in Table 5.7-24.

Table 5.7-24: Cost estimates for the proposed Delaney – Colorado River 500 kV

NPV of annualized revenue requirement, 2012 constant dollars		
	5% Real Social Discount Rate	7% Real Social Discount Rate
10% ROE, 7% state tax	530 million	442 million
11% ROE, 8.84% state tax	560 million	469 million

### 5.7.4.6 Cost-benefit analysis

Based on yearly benefits calculated above, the total benefit is calculated in the present value using both a 7 percent and a 5 percent social discount rate, and the using the cost ranges calculated above, benefit-cost ratio ranges are also calculated as shown in Tables 5.7-25 and 5.7-26.

Table 5.7-25: Cost-benefit analysis of the proposed Delaney – Colorado River 500 kV

<b>7% discount rate</b>	<b>Capacity Benefit</b>	
	<b>200 MW</b>	<b>300 MW</b>
Total benefit (\$M)	406	477
Total cost (\$M)	442-469	442-469
Benefit-cost ratio	.87-.93	1.02-1.09

Table 5.7-26: Cost-benefit analysis of the proposed Delaney – Colorado River 500 kV

<b>5% discount rate (sensitivity)</b>	<b>Capacity Benefit</b>	
	<b>200 MW</b>	<b>300 MW</b>
Total benefit (\$M)	528	617
Total cost (\$M)	530-560	530-560
Benefit-cost ratio	.95-1.0	1.11-1.17

### 5.7.4.7 Sensitivity analyses

Figure 5.7-17 graphically shows the sensitivity of the economic benefits of the Palo Verde – Colorado River 500 kV line. Production benefits were calculated in a sensitivity analysis under different varied assumptions. For simplicity, the net present values of the production simulation benefit, capacity benefit, and revenue requirement were calculated for the two import transfer capability levels and the different financial parameters shown above and then averaged. It was also assumed that the relative differences from sensitivity results would not significantly change for limited subsequent updates to the model.



Figure 5.7-17: Sensitivity analyses

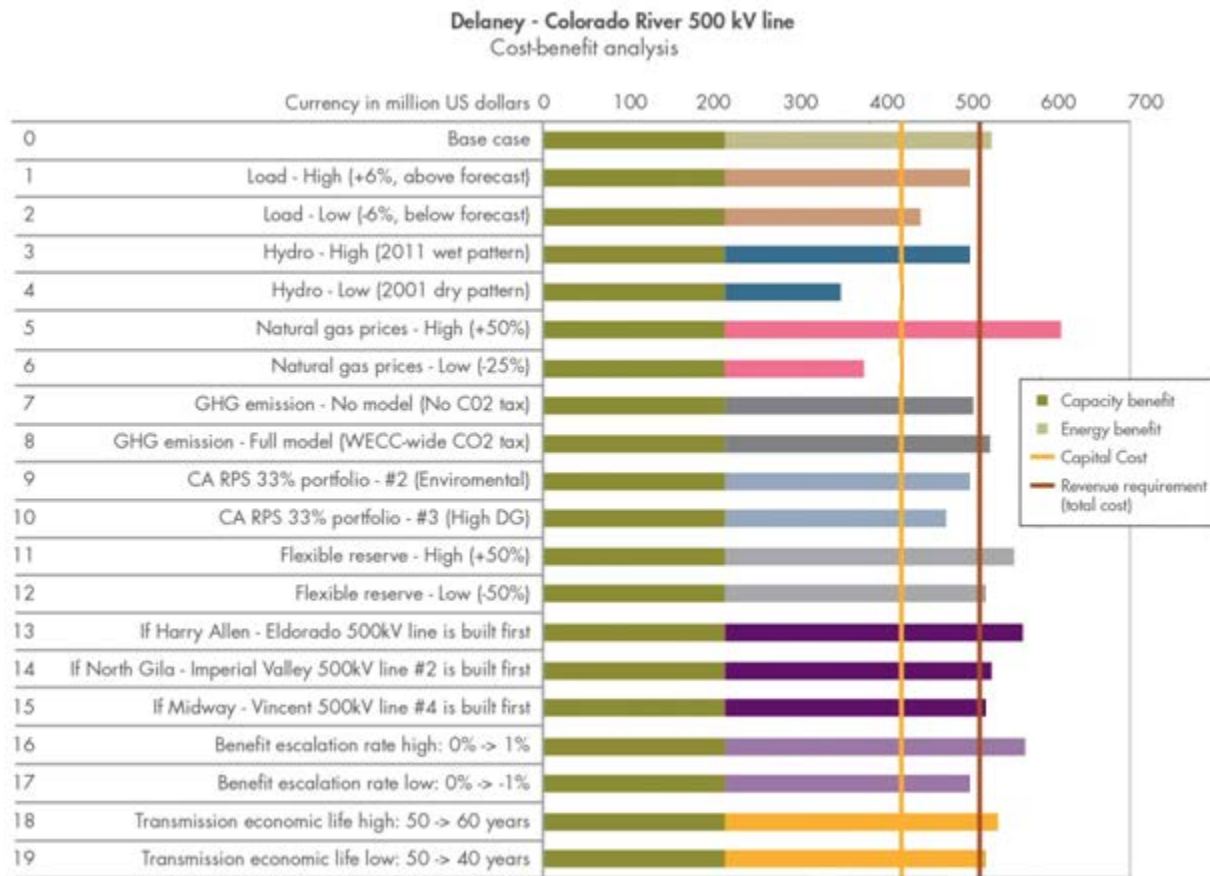

**5.7.4.8 Recommendation**

The Delaney – Colorado River 500 kV<sup>54</sup> line is recommended for approval in this transmission plan, based on:

- Sufficient economic benefits demonstrated relative to the estimated cost of the project. Sensitivity analyses also showed economic benefits under a majority of assumptions and uncertainties,
- Potential for policy benefits in increasing the deliverability from the Imperial Valley area, and,
- Reliability benefits in reducing flows on key transmission paths.

The economic justification for the project is dependent on its estimated cost, and as a result cost estimates and cost management information provided by project sponsors will be carefully considered with respect to the estimated cost assumed in the ISO’s economic analysis.

<sup>54</sup> The Delaney-Colorado River 500 kV line was not approved by the ISO Board of Governors at the March 20, 2014 ISO Board meeting.

### 5.7.5 North Gila – Imperial Valley 500 kV line #2

This section describes the economic planning study of the proposed North Gila – Imperial Valley 500 kV line #2.

#### 5.7.5.1 Congestion analysis

Table 5.7-27 lists simulation results of congestion hours before and after adding the North Gila – Imperial Valley 500 kV line #2, for the facilities that were identified as congested in Table 5.6-1.

Table 5.7-27: Congestion hours before and after adding the North Gila – Imperial Valley 500 kV line #2

#	Transmission Facilities	Year 2018		Year 2023	
		Before	After	Before	After
1	Path 66 (COI) nomogram	3	3	-	-
2	Path 25 (PacifiCorp – PG&E 115 kV Interconnection)	488		651	636
3	Contra Costa Sub – Contra Costa 230 kV line	4	2	15	18
4	US Wind Power – JRW – Cayetano 230 kV line, subject to loss of Contra Costa – Las Positas 230 kV line	-	-	1	1
5	Midway – Vincent 500 kV line #1 or #2	1	1	4	4
6	Midway – Vincent 500 kV line #1, subject to loss of #2 line, or vice versa	69	63	28	29
7	Midway – Vincent 500 kV line #1 or #2, subject to loss of Midway – Whirlwind line	111	93	37	34
8	Path 26 (Northern – Southern California)	692	670	468	428
9	Path 26 north-to-south Operating Transfer Capability	5	3	8	5
10	Vincent 500/230 kV transformer #1	6	5	4	2
11	Villa Park – Lewis 230 kV line, subject to loss of Villa Park - Barre 230 kV line	2	1	-	-
12	Lewis – Barre 230 kV line, subject to loss of Villa Park – Barre 230 kV line (or loss of Serrano – Lewis 230 kV line)	70	47	-	-
13	Barre - Ellis 230 kV line, subject to loss of Hassayampa – North Gila 500 kV lines	2	-	-	-
14	Litehipe – Hinson 230 kV line, subject to loss of La Fresno - Redondo 230 kV line	3	5	-	-

#	Transmission Facilities	Year 2018		Year 2023	
		Before	After	Before	After
15	Julian Hinds – Mirage 230 kV	83	77	7	5
16	Kramer – Lugo 230 kV line #1 and #2	623	627	85	82
17	Inyo 115 kV phase shifter	769	766	760	732
18	Control – Inyokern 115 kV line #1	-	-	34	32
19	Control – Tap710 115 kV line	-	-	458	449
20	Miguel 500/230 kV transformer #1, subject loss of transformer #2	-	18	1	12
21	SCIT limits	23	-	2	-

#### 5.7.5.2 Impacts to dispatch and LMP

Figure 5.7-18 shows generation dispatch changes with addition of the North Gila – Imperial Valley 500 kV line #2. It can be seen that the line will facilitate increased use of efficient generation located at APS, Palo Verde trading hub and SRP. The increased use of efficient generation will displace more expensive generation in Southern California. Although to a lesser extent, more expensive generation in Northern California is also displaced.

Figure 5.7-18: Generation changes with addition of the Imperial Valley – North Gila 500 kV line #2

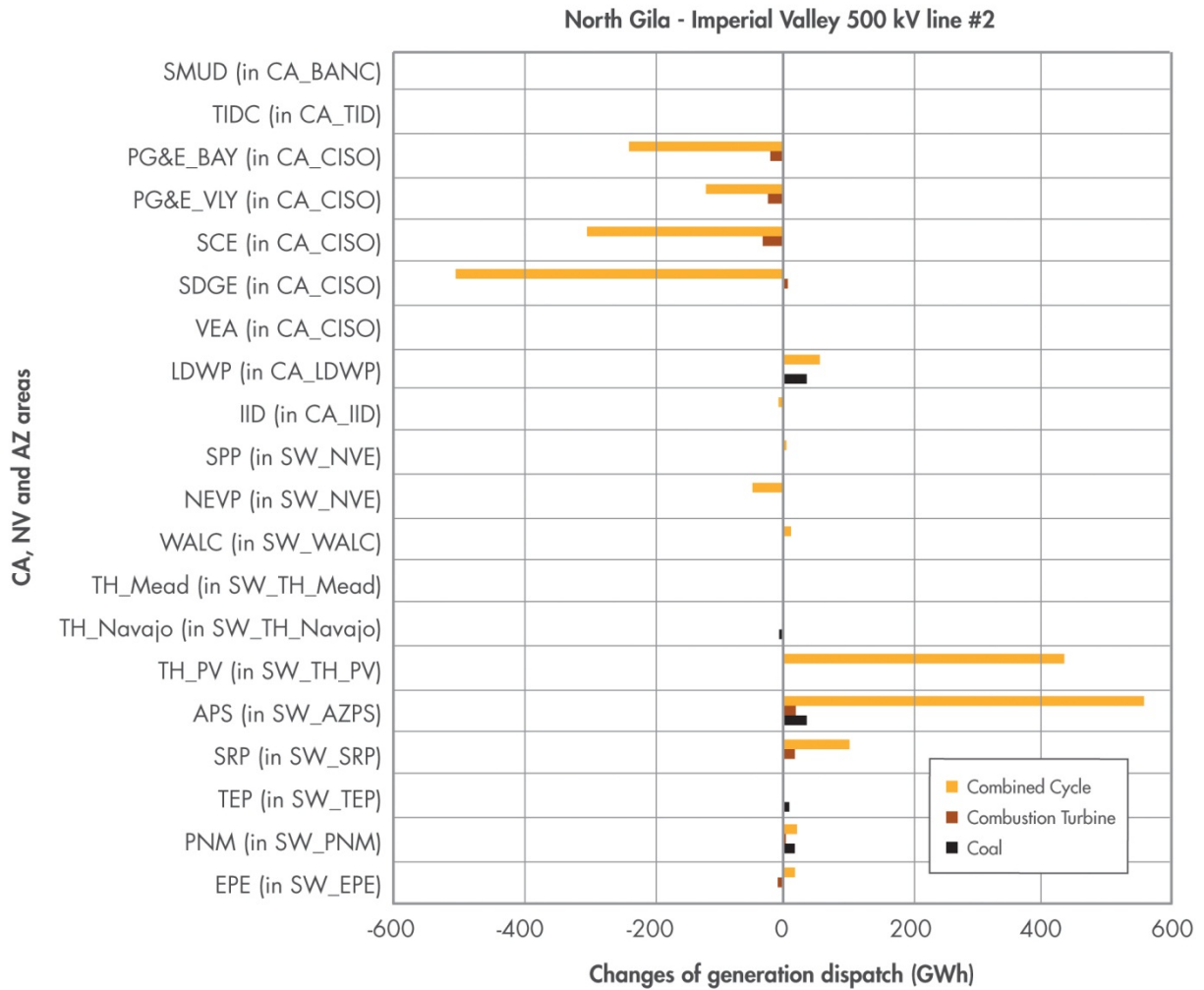
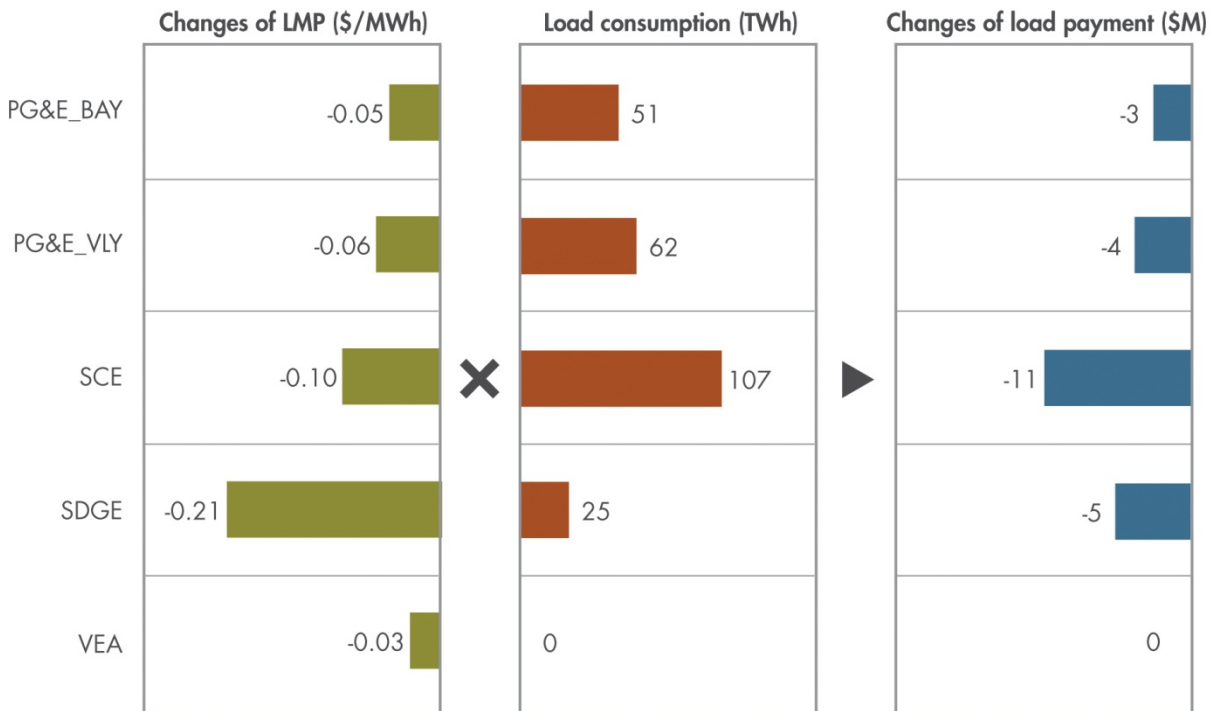

Figure 5.7-19 shows the resulting changes of LMP and load payments. It can be seen that the North Gila – Imperial Valley 500 kV line #2 will reduce the LMP in the ISO-controlled grid. The LMP reduction leads to reduced load payment for the ISO ratepayers. In terms of the magnitudes of LMP decrease, SDG&E is the biggest beneficiary, followed by SCE and PG&E.

Figure 5.7-19: LMP and load payment changes with addition of the Imperial Valley – North Gila 500 kV line #2



Simulation year 2023  
 The "Changes of LMP (\$/MWh)" is the difference of annual averages

**5.7.5.3 Production benefits**

Based on 8,760 hourly production simulations for the study years, yearly benefits are calculated as \$21 million in 2018 and \$20 million in 2023, respectively. In addition, we estimated losses reduction benefit outside the production simulation model using a traditional power flow calculation. In this case, the losses reduction benefit is considered negligible. Table 5.7-28 lists quantified yearly production benefits.

Table 5.7-28: Yearly production benefits of building a new North Gila – Imperial Valley 500 kV line #2

<b>Yearly production benefit</b>			
<b>Year</b>	<b>Production benefit calculated by production simulation</b>	<b>Losses reduction benefit estimated outside the production simulation model</b>	<b>Sum</b>
2018	\$21M	0	\$21M
2023	\$20M		\$20M

#### 5.7.5.4 Capacity benefits

Because of downstream bottlenecks in the SDG&E system, the capacity benefits are expected to be zero. See Table 5.7-29.

Table 5.7-29: Yearly capacity benefits of building a new North Gila – Imperial Valley 500 kV line #2

<b>Yearly capacity benefit</b>			
<b>Year</b>	<b>System RA benefit</b>	<b>LCR benefit</b>	<b>Sum</b>
-	-	-	-

#### 5.7.5.5 Cost estimates

For the proposed North Gila – Imperial Valley 500 kV line #2, the capital cost is estimated as \$295 million; and the total cost (revenue requirement) is estimated at \$428 million using a “CC-to-RR multiplier” of 1.45. The cost estimates are listed in Table 5.7-30.

Table 5.7-30: Cost estimates for the proposed North Gila – Imperial Valley 500 kV line #2

<b>Capital cost</b>	<b>Total cost (revenue requirement)</b>
\$295M	\$428M

### 5.7.5.6 *Cost-benefit analysis*

Based on yearly benefits determined in Sections 5.7.5.3 and 5.7.5.4, total benefit is calculated in the present value on the assumed operation year. A cost-benefit analysis is provided in Table 5.7-31.

Table 5.7-31: Cost-benefit analysis of the proposed North Gila – Imperial Valley 500 kV line #2

<b>Assumed operation year: 2018</b>			
<b>Total benefit (\$M)</b>	<b>Total cost (\$M)</b>	<b>Net benefit (\$M)</b>	<b>Benefit-cost ratio</b>
279	428	(149)	0.65

### 5.7.5.7 *Recommendation*

At this point, there is not sufficient economic justification to approve the proposed North Gila – Imperial Valley 500 kV line project. Both the production benefit (to a lesser extent) and capacity benefit (to a larger extent) are limited by downstream system issues.

The ISO will continue to study this transmission line in future planning studies. When the downstream system limitations are relieved, the North Gila – Imperial Valley 500 kV line holds the promise of having more economic benefits.

## 5.8 Summary

Production simulation was conducted for 8,760 hours in each study year for 2018 and 2023 in this economic planning study and grid congestion was identified and evaluated. According to the identified areas of congestion concerns, five high-priority studies were conducted and proposed network upgrades were evaluated. The five high-priority studies evaluated 11 network upgrade alternatives for their economic benefits in the following study areas:

1. build a new Midway – Vincent 500 kV line #4;
2. upgrade the existing Pacific DC Intertie (PDCI) by increasing rating 500 MW;
3. build a new Harry Allen – Eldorado 500 kV line;
4. build a new Delaney – Colorado River 500 kV line; and
5. build a new North Gila – Imperial Valley 500 kV line #2.

The recommendations are as follows:

1. For the proposed Midway – Vincent 500 kV line #4 the study did not identify significant economic benefit, although Path 26 congestion has been top-ranked in the economic planning studies. In the absence of justifications for a Path 26 upgrade, the ISO will continue to rely on congestion management to address this constraint.
2. For the proposed PDCI upgrade the study did not identify significant economic benefit. As COI and PDCI are very important inter-regional transmission facilities, the ISO will continue to do future analysis on these facilities.
3. The proposed Harry Allen – Eldorado 500 kV line is a promising economic study subject. However, the current study is considered preliminary as the modeling is not yet updated to include EIM in NV Energy.
4. For the proposed Delaney – Colorado River 500 kV line it was found the line has significant economic benefit and that the benefit outweighs the cost. Sensitivity analyses demonstrated robustness of the economic benefit under a variety of study assumptions. It is recommended to approve the Delaney – Colorado River 500 kV<sup>55</sup> line as an economically driven network upgrade, subject to the ISO's competitive solicitation process.
5. The proposed North Gila – Imperial Valley 500 kV line #2 is a promising economic study subject. The line may have more benefit in the future if downstream transmission bottlenecks are substantially relieved. The ISO will continue to conduct economic assessment for this identified transmission line in future studies.

---

<sup>55</sup> The Delaney-Colorado River 500 kV line was not approved by the ISO Board of Governors at the March 20, 2014 ISO Board meeting.



## Chapter 6

### 6 Other Studies and Results

#### 6.1 Long-Term Congestion Revenue Rights Simultaneous Feasibility Test Studies

The Long-term Congestion Revenue Rights (LT CRR) Simultaneous Feasibility Test studies evaluate the feasibility of the fixed LT CRRs previously released through the CRR annual allocation process under seasonal, on-peak and off-peak conditions, consistent with section 4.2.2 of the Business Practice Manual for Transmission Planning Process and tariff sections 24.1 and 24.4.6.4

##### 6.1.1 Objective

The primary objective of the LT CRR feasibility study is to ensure that fixed LT CRRs released as part of the annual allocation process remain feasible over their entire 10-year term, even as new and approved transmission infrastructure is added to the ISO-controlled grid.

##### 6.1.2 Data Preparation and Assumptions

The 2013 LT CRR study leveraged the base case network topology used for the annual 2013 CRR allocation and auction process. Regional transmission engineers responsible for long-term grid planning incorporated all the new and ISO approved transmission projects into the base case and a full alternating current (AC) power flow analysis to validate acceptable system performance. These projects and system additions were then added to the base case network model for CRR applications. The modified base case was then used to perform the market run, CRR simultaneous feasibility test (SFT), to ascertain feasibility of the fixed CRRs. A list of the approved projects can be found in the 2012-2013 Transmission Plan.

In the SFT-based market run, all CRR sources and sinks from the released CRR nominations were applied to the full network model (FNM). This forms the core network model for the locational marginal pricing (LMP) markets. All applicable constraints were considered to determine flows as well as to identify the existence of any constraint violations. In the long-term CRR market run setup, the network was limited to 60 percent of available transmission capacity. The fixed CRR representing the transmission ownership rights and merchant transmission were also set to 60 percent. All earlier LT CRR market awards were set to 100 percent. For the study year, the market run was set up for four seasons (with season 1 being January through March) and two time-of-use periods (reflecting on-peak and off-peak system conditions). The study setup and market run are conducted in the CRR study system. This system provides a reliable and convenient user interface for data setup and results display. It also provides the capability to archive results as save cases for further review and record-keeping.

The ISO regional transmission engineering group and CRR team must closely collaborate to ensure that all data used were validated and formatted correctly. The following criteria were used to verify that the long-term planning study results maintain the feasibility of the fixed LT CRRs:

- SFT is completed successfully;
- the worst case base loading in each market run does not exceed 60 percent of enforced branch rating;
- there are overall improvements on the flow of the monitored transmission elements.

### **6.1.3 Study Process, Data and Results Maintenance**

A brief outline of the current process is as follows:

- The base case network model data for long-term grid planning is prepared by the regional transmission engineering (RTE) group. The data preparation may involve using one or more of these applications: PTI PSS/E, GE PSLF and MS Excel;
- RTE models new and approved projects and perform the AC power flow analysis to ensure power flow convergence;
- RTE reviews all new and approved projects for the transmission planning cycle;
- applicable projects are modeled into the base case network model for the CRR allocation and auction in collaboration with the CRR team, consistent with the BPM for Transmission Planning Process section 4.2.2;
- CRR team sets up and performs market runs in the CRR study system environment in consultation with the RTE group;
- CRR team reviews the results using user interfaces and displays, in close collaboration with the RTE group; and
- The input data and results are archived to a secured location as saved cases.

### **6.1.4 Conclusions**

The SFT studies involved six market runs that reflected four three-month seasonal periods (January through December) and two time-of-use (on-peak and off-peak) conditions.

The results indicated that all existing fixed LT CRRs remained feasible over their entire 10-year term as the planned.

In compliance with Section 24.4.6.4 of the ISO tariff, ISO followed the LTCRR SFT study steps outlined in Section 4.2.2 of the BPM for the Transmission Planning Process to determine whether there are any existing released LT CRRs that could be at risk and for which mitigation measures should be developed. Based on the results of this analysis, the ISO determined that there are no existing released LT CRRs at-risk” that require further analysis. Thus, the transmission projects and elements did not adversely impact feasibility of the existing released LT CRRs. The studies also showed general improvement in transmission facility loading after the transmission projects were added.

## Chapter 7

### 7 Transmission Project List

#### 7.1 Transmission Project Updates

Tables 7.1-1 and 7.1-2 provide updates on expected in-service dates of previously approved transmission projects. In previous transmission plans, the ISO determined these projects were needed to mitigate identified reliability concerns, interconnect new renewable generation via a location constrained resource interconnection facility project or enhance economic efficiencies.

Table 7.1-1: Status of previously approved projects costing less than \$50M

No	Project	PTO	Expected In-Service Date
1	New and/or Upgrade of 69 kV Capacitors	SDG&E	Jun-13
2	New Sycamore - Bernardo 69 kV line (being replaced with Bernardo-Ranche Carmel-Poway 69 kV lines upgrade)	SDG&E	Cancelled
3	Reconductor TL663, Mission-Kearny	SDG&E	Jun-15
4	Reconductor TL670, Mission-Clairemont	SDG&E	Jun-14
5	Reconductor TL676, Mission-Mesa Heights	SDG&E	Jun-15
6	Replace Talega Bank 50	SDG&E	Jun-14
7	Sweetwater Reliability Enhancement	SDG&E	Jun-17
8	TL626 Santa Ysabel – Descanso mitigation (TL625B loop-in, Loveland - Barrett Tap loop-in)	SDG&E	Jun-14
9	TL631 El Cajon-Los Coches Reconductor	SDG&E	Jun-14
10	TL633 Bernardo-Rancho Carmel Reconductor	SDG&E	Jun-15
11	TL644, South Bay-Sweetwater: Reconductor	SDG&E	TBD
12	TL674A Loop-in (Del Mar-North City West) & Removal of TL666D (Del Mar-Del Mar Tap)	SDG&E	Jun-15

No	Project	PTO	Expected In-Service Date
13	TL694A San Luis Rey-Morro Hills Tap: Reliability (Loop-in TL694A into Melrose)	SDG&E	Jun-14
14	TL695B Japanese Mesa-Talega Tap Reconductor	SDG&E	Jun-15
15	TL6913, Upgrade Pomerado - Poway	SDG&E	2014
16	TL 13820, Sycamore-Chicarita Reconductor	SDG&E	Jun-14
17	Upgrade Los Coches 138/69 kV Bank 50	SDG&E	Jun-15
18	Upgrade Los Coches 138/69 kV bank 51	SDG&E	Jun-15
19	Cross Valley Rector Loop Project	SCE	Apr-14
20	East Kern Wind Resource Area 66 kV Reconfiguration Project	SCE	Jun-14
21	Lugo-Eldorado 500 kV Line Reroute	SCE	2015
22	Lugo Substation Install new 500 kV CBs for AA Banks	SCE	Dec-15
23	Method of Service for Wildlife 230/66 kV Substation.	SCE	Jul-15
24	Path 42 and Devers – Mirage 230 kV Upgrades	SCE	Apr-14
25	Rector Static Var System (SVS) Project (Expand Rector SVS)	SCE	Jun-14
26	Almaden 60 kV Shunt Capacitor	PG&E	May-17
27	Arco #2 230/70 kV Transformer	PG&E	Dec-13
28	Ashlan-Gregg and Ashlan-Herndon 230 kV Line Reconductor	PG&E	May-18
29	Atlantic-Placer 115 kV Line	PG&E	May-17
30	Bay Meadows 115 kV Reconductoring	PG&E	Dec-16

No	Project	PTO	Expected In-Service Date
31	Borden 230 kV Voltage Support	PG&E	May-19
32	Caruthers – Kingsburg 70 kV Line Reconductor	PG&E	May-18
33	Cascade 115/60 kV No.2 Transformer Project and Cascade - Benton 60 kV Line Project	PG&E	May-19
34	Cayucos 70 kV Shunt Capacitor	PG&E	May-17
35	Christie 115/60 kV Transformer No. 2	PG&E	Jun-15
36	Clear Lake 60 kV System Reinforcement	PG&E	May-19
37	Contra Costa – Moraga 230 kV Line Reconductoring	PG&E	Jun-16
38	Contra Costa Sub 230 kV Switch Replacement	PG&E	May-16
39	Cooley Landing - Los Altos 60 kV Line Reconductor	PG&E	May-17
40	Cooley Landing 115/60 kV Transformer Capacity Upgrade	PG&E	Dec-17
41	Corcoran 115/70 kV Transformer Replacement Project	PG&E	Mar-13
42	Cortina 60 kV Reliability	PG&E	Mar-15
43	Cortina No.3 60 kV Line Reconductoring Project	PG&E	May-18
44	Crazy Horse Switching Station	PG&E	Feb-15
45	Cressey-Gallo 115 kV Line	PG&E	Jun-15
46	Cressey - North Merced 115 kV Line Addition	PG&E	May-18
47	Del Monte - Fort Ord 60 kV Reinforcement Project	PG&E	Phase 1 – In-Service Phase 2 - May-18
48	Diablo Canyon Voltage Support Project	PG&E	May-18

No	Project	PTO	Expected In-Service Date
49	East Nicolaus 115 kV Area Reinforcement	PG&E	Oct-14
50	East Shore-Oakland J 115 kV Reconductoring Project (name changed from East Shore-Oakland J 115 kV Reconductoring Project & Pittsburg-San Mateo 230 kV Looping Project since only the 115 kV part was approved)	PG&E	May-18
51	Evergreen-Mabury Conversion to 115 kV	PG&E	May-19
52	Fulton 230/115 kV Transformer	PG&E	Dec-17
53	Fulton-Fitch Mountain 60 kV Line Reconductor	PG&E	May-17
54	Garberville Reactive Support	PG&E	Nov-13
55	Geysers #3 - Cloverdale 115 kV Line Switch Upgrades	PG&E	May-16
56	Glenn #1 60 kV Reconductoring	PG&E	May-18
57	Gold Hill-Horseshoe 115 kV Reinforcement	PG&E	Mar-13
58	Gregg-Herndon #2 230 kV Line Circuit Breaker Upgrade	PG&E	May-16
59	Half Moon Bay Reactive Support	PG&E	May-13
60	Helm-Kerman 70 kV Line Reconductor	PG&E	May-17
61	Herndon 230/115 kV Transformer Project	PG&E	Dec-13
62	Hollister 115 kV Reconductoring	PG&E	Aug-13
63	Humboldt - Eureka 60 kV Line Capacity Increase	PG&E	May-17
64	Humboldt 115/60 kV Transformer Replacements	PG&E	May-13
65	Ignacio - Alto 60 kV Line Voltage Conversion	PG&E	May-19
66	Jefferson-Stanford #2 60 kV Line	PG&E	Dec-17
67	Kern - Old River 70 kV Line Reconductor Project	PG&E	May-16

No	Project	PTO	Expected In-Service Date
68	Kern PP 230 kV Area Reinforcement	PG&E	May-19
69	Kearney #2 230/70 kV Transformer	PG&E	May-16
70	Kearney-Caruthers 70 kV Line Reconductor	PG&E	May-17
71	Kearney - Hearndon 230 kV Line Reconductoring	PG&E	Dec-18
72	Kerchhoff PH #2 - Oakhurst 115 kV Line	PG&E	May-18
73	Lemoore 70 kV Disconnect Switches Replacement	PG&E	May-15
74	Lockheed No.1 115 kV Tap Reconductor	PG&E	May-17
75	Los Banos-Livingston Jct-Canal 70 kV Switch Replacement	PG&E	May-16
76	Los Esteros-Montague 115 kV Substation Equipment Upgrade	PG&E	May-17
77	Maple Creek Reactive Support	PG&E	Dec-16
78	Mare Island - Ignacio 115 kV Reconductoring Project	PG&E	May-19
79	Mendocino Coast Reactive Support	PG&E	Dec-14
80	Menlo Area 60 kV System Upgrade	PG&E	Oct-15
81	Mesa-Sisquoc 115 kV Line Reconductoring	PG&E	May-17
82	Metcalf-Evergreen 115 kV Line Reconductoring	PG&E	May-19
83	Metcalf-Piercy & Swift and Newark-Dixon Landing 115 kV Upgrade	PG&E	May-20
84	Midway-Kern PP Nos. 1,3 and 4 230 kV Lines Capacity Increase	PG&E	May-17
85	Midway-Temblor 115 kV Line Reconductor and Voltage Support	PG&E	May-20
86	Missouri Flat - Gold Hill 115 kV Line	PG&E	Jun-17

No	Project	PTO	Expected In-Service Date
87	Monta Vista - Los Altos 60 kV Reconductoring	PG&E	May-19
88	Monta Vista - Los Gatos - Evergreen 60 kV Project	PG&E	May-18
89	Monte Vista 230 kV Bus Upgrade	PG&E	May-17
90	Monta Vista-Wolfe 115 kV Substation Equipment Upgrade	PG&E	May-16
91	Moraga Transformers Capacity Increase	PG&E	Dec-16
92	Moraga-Castro Valley 230 kV Line Capacity Increase Project	PG&E	Dec-18
93	Moraga-Oakland "J" SPS Project	PG&E	May-16
94	Morro Bay 230/115 kV Transformer Addition Project	PG&E	May-19
95	Mountain View/Whisman-Monta Vista 115 kV Reconductoring	PG&E	May-19
96	Napa - Tulucay No. 1 60 kV Line Upgrades	PG&E	May-17
97	Navidad Substation Interconnection	PG&E	May-18
98	Newark – Ravenswood 230 kV Line	PG&E	Dec-15
99	Newark-Applied Materials 115 kV Substation Equipment Upgrade Project	PG&E	May-17
100	North Tower 115 kV Looping Project	PG&E	Dec-18
101	NRS-Scott No. 1 115 kV Line Reconductor	PG&E	May-17
102	Oakhurst/Coarsegold UVLS	PG&E	May-16
103	Oro Loma - Mendota 115 kV Conversion Project	PG&E	May-17
104	Oro Loma 70 kV Area Reinforcement	PG&E	May-18
105	Pease 115/60 kV Transformer Addition and Bus Upgrade	PG&E	May-17



No	Project	PTO	Expected In-Service Date
106	Pease-Marysville #2 60 kV Line	PG&E	Dec-18
107	Pittsburg – Tesla 230 kV Reconductoring	PG&E	Dec-14
108	Pittsburg 230/115 kV Transformer Capacity Increase	PG&E	Dec-18
109	Pittsburg-Lakewood SPS Project	PG&E	Jul-14
110	Potrero 115 kV Bus Upgrade	PG&E	May-19
111	Ravenswood - Cooley Landing 115 kV Line Reconductor	PG&E	Dec-17
112	Reedley 70 kV Reinforcement	PG&E	May-18
113	Reedley-Dinuba 70 kV Line Reconductor	PG&E	May-17
114	Reedley-Orosi 70 kV Line Reconductor	PG&E	May-17
115	Rio Oso - Atlantic 230 kV Line Project	PG&E	May-19
116	Rio Oso 230/115 kV Transformer Upgrades	PG&E	Dec- 18
117	Rio Oso Area 230 kV Voltage Support	PG&E	Dec- 18
118	Ripon 115 kV Line	PG&E	May-16
119	Salado 115/60 kV Transformer Addition	PG&E	Nov-14
120	San Mateo - Bair 60 kV Line Reconductor	PG&E	May-18
121	Santa Cruz 115 kV Reinforcement	PG&E	Dec-16
122	Semitropic - Midway 115 kV Line Reconductor	PG&E	May-20
123	Series Reactor on Warnerville-Wilson 230 kV Line	PG&E	Dec-17
124	Shepherd Substation	PG&E	Jun-15
125	Soledad 115/60 kV Transformer Capacity	PG&E	May-19
126	South of San Mateo Capacity Increase	PG&E	Apr-19

No	Project	PTO	Expected In-Service Date
127	Stagg – Hammer 60 kV Line	PG&E	May-19
128	Stockton 'A' -Weber 60 kV Line Nos. 1 and 2 Reconductor	PG&E	May-17
129	Stone 115 kV Back-tie Reconductor	PG&E	May-17
130	Table Mountain – Sycamore 115 kV Line	PG&E	May-19
131	Taft 115/70 kV Transformer #2 Replacement	PG&E	May-19
132	Tesla 115 kV Capacity Increase	PG&E	Dec-15
133	Tesla-Newark 230 kV Path Upgrade	PG&E	Dec-18
134	Trans Bay Cable Dead Bus Energization Project	PG&E	May-15
135	Tulucay 230/60 kV Transformer No. 1 Capacity Increase	PG&E	May-16
136	Vaca Dixon - Lakeville 230 kV Reconductoring	PG&E	Feb-17
137	Valley Spring 230/60 kV Transmission Addition:	PG&E	Dec-13
138	Vierra 115 kV Looping Project	PG&E	May-19
139	Warnerville-Bellota 230 kV line reconductoring	PG&E	Dec-18
140	Watsonville Voltage Conversion	PG&E	Dec-18
141	Weber 230/60 kV Transformer Nos. 2 and 2A Replacement	PG&E	Apr-16
142	West Coast Recycling - Load Interconnection	PG&E	Mar-14
143	West Point – Valley Springs 60 kV Line	PG&E	May-19
144	West Point - Valley Springs 60 kV Line Project (Second Line)	PG&E	May-19
145	Wheeler Ridge 230/70 kV Transformer	PG&E	Mar-14
146	Wheeler Ridge Voltage Support	PG&E	May-20

<b>No</b>	<b>Project</b>	<b>PTO</b>	<b>Expected In-Service Date</b>
147	Wilson 115 kV Area Reinforcement	PG&E	May-18
148	Wilson-Le Grand 115 kV line reconductoring	PG&E	Dec-20
149	Woodward 115 kV Reinforcement	PG&E	Dec-17
150	Imperial Valley Transmission Line Collector Station Project	IID	May-15

Table 7.1-2: Status of previously approved projects costing \$50M or more

No	Project	PTO	Expected In-Service Date
1	Bay Boulevard 230/69 kV Substation Project	SDG&E	Jun-17
2	South Orange County Dynamic Reactive Support	SDG&E	Dec-17
3	Southern Orange County Reliability Upgrade Project - Alternative 3 (Rebuild Capistrano Substation, construct a new SONGS-Capistrano 230 kV line and a new 230 kV tap line to Capistrano)	SDG&E	Jun-17
4	Sycamore-Penasquitos 230 kV Line	Undergoing solicitation process	May-17
5	Talega Area Dynamic Reactive Support	SDG&E	Jun-15
6	Alberhill 500 kV Method of Service	SCE	Jun-17
7	Lugo – Eldorado series cap and terminal equipment upgrade	SCE	2016
8	Tehachapi Transmission Project	SCE	2016
9	Atlantic-Placer 115 kV Line	PG&E	May-19
10	Cottonwood-Red Bluff No. 2 60 kV Line Project and Red Bluff Area 230/60 kV Substation Project	PG&E	May-19
11	Embarcadero-Potrero 230 kV Transmission Project	PG&E	Dec-15
12	Fresno Reliability Transmission Projects	PG&E	Dec-15
13	Gates #2 500/230 kV Transformer Addition	PG&E	Dec-17

No	Project	PTO	Expected In-Service Date
14	Gates-Gregg 230 kV Line <sup>56</sup>	PG&E/MAT	Dec-22
15	Kern PP 115 kV Area Reinforcement	PG&E	May-20
16	Lockeford-Lodi Area 230 kV Development	PG&E	May-20
17	Midway-Andrew 230 kV Project	PG&E	Dec-20
18	New Bridgeville - Garberville No.2 115 kV Line	PG&E	May-20
19	Northern Fresno 115 kV Reinforcement	PG&E	May-19
20	Palermo – Rio Oso 115 kV Line Reconductoring	PG&E	May-14
21	South of Palermo 115 kV Reinforcement Project	PG&E	May-19
22	Vaca – Davis Voltage Conversion Project	PG&E	May-19
23	Warnerville-Bellota 230 kV line reconductoring	PG&E	2017
24	Wilson-Le Grand 115 kV line reconductoring	PG&E	2020

<sup>56</sup> During its 2012-13 transmission planning cycle, the ISO approved the Gates-Gregg 230 kV project as a double-circuit tower line with a single conductor to be strung initially. Through the solicitation process the project has been awarded to PG&E, MidAmerican Transmission, and Citizens Energy (the “Gates-Gregg project sponsors”). At this time the ISO has not approved the need for the second circuit; however it would be prudent for the Gates-Gregg project sponsors to seek permits for the second circuit in parallel with or as a part of their permitting for the currently-approved Gates-Gregg project.

## 7.2 Transmission Projects found to be needed in the 2013-2014 Planning Cycle

In the 2013-2014 transmission planning process, the ISO determined that 28 transmission projects were needed to mitigate identified reliability concerns, 2 policy-driven projects were needed to meet the 33 percent RPS and 1<sup>57</sup> economically driven project was found to be needed. The summary of these transmission projects are in the tables below.

A list of projects that came through the 2013 Request Window can be found in Appendix E.

Table 7.2-1: New reliability projects found to be needed

No.	Project Name	Service Area	Expected In-Service Date	Project Cost
1	2nd Escondido-San Marcos 69 kV T/L	SDG&E Area	Jun-15	\$18-22M
2	Additional 450 MVAR of dynamic reactive support at San Luis Rey (i.e., two 225 MVAR synchronous condensers)	SDG&E Area	Jun-18	\$80M
3	Artesian 230 kV Sub & loop-in TL23051	SDG&E Area	Jun-16	\$44-64M
4	Imperial Valley Flow Controller (IV B2BDC or Phase Shifter)	SDG&E Area	May-17	\$55-300M
5	Miguel 500 kV Voltage Support	SDG&E Area	May-17	\$30-40M
6	Miramar-Mesa Rim 69 kV System Reconfiguration	SDG&E Area	Jun-18	\$5-7M
7	Mission Bank #51 and #52 replacement	SDG&E Area	Jun-18	\$10M
8	Rose Canyon-La Jolia 69 kV T/L	SDG&E Area	Jun-18	\$3.2-4M

<sup>57</sup> There are no economically driven projects approved as the Delaney-Colorado River 500 kV line was not approved by the ISO Board of Governors at the March 20, 2014 ISO Board meeting.

No.	Project Name	Service Area	Expected In-Service Date	Project Cost
9	Bernardo-Ranche Carmel-Poway 69 kV lines upgrade (replacing previously approved New Sycamore - Bernardo 69 kV line)	SDG&E Area	Jun-16	\$28M
10	TL690A/TL690E, San Luis Rey-Oceanside Tap and Stuart Tap-Las Pulgas 69 kV sections re-conducto	SDG&E Area	Jun-15	\$24-28M
11	TL13834 Trabuco-Capistrano 138 kV Line Upgrade	SDG&E Area	Jun-18	<\$1M
12	Mesa Loop-in	Metro Area	Dec-20	\$464-614M
13	Victor Loop-in	North of Lugo Area	2015	\$12M
14	CT Upgrade at Mead-Pahrump 230 kV Terminal	VEA Area	2014	\$100k
15	Estrella Substation Project	Central Cost & Los Padres Area	May-19	\$35-45M
16	Glenn 230/60 kV Transformer No. 1 Replacement	North Valley	2018	\$5-10M
17	Kearney-Kerman 70 kV Line Reconductor	Fresno Area	May-18	\$12-18M
18	Laytonville 60 kV Circuit Breaker Installation Project	North Coast and North Bay Area	Dec-15	\$5-10M
19	McCall-Reedley #2 115 kV Line	Fresno Area	May-19	\$25-40M
20	Midway-Kern PP #2 230 kV Line	Kern Area	May-19	\$60-90M
21	Morgan Hill Area Reinforcement	Great Bay Area	2021	\$35-45M
22	Mosher Transmission Project	Central Valley	2017	\$10-15M

No.	Project Name	Service Area	Expected In-Service Date	Project Cost
23	Reedley 115/70 kV Transformer Capacity Increase	Fresno Area	Phase 1- May-15 Phase 2- May-18	\$12-18M
24	San Bernard – Tejon 70 kV Line Reconductor	Kern Area	May-18	\$8-12M
25	Taft-Maricopa 70 kV Line Reconductor	Kern Area	May-18	\$6-10M
26	Weber-French Camp 60 kV Line Reconfiguration	Central Valley	2016	\$7-8.4M
27	Wheeler Ridge Junction Station	Kern Area	May-20	\$90-140M
28	Wheeler Ridge-Weedpatch 70 kV Line Reconductor	Kern Area	May-18	\$15M-\$25M

Table 7.2-2: New policy-driven transmission project found to be needed

No.	Project Name	Project Type	Expected In-Service Date	Project Cost
1	Suncrest 300 MVAR dynamic reactive device	Policy-driven project	2017	\$65M
2	Lugo-Mohave series capacitor upgrade	Policy-driven project	2016	\$70M



Table 7.2-3: New economically driven transmission project found to be needed

<b>No.</b>	<b>Project Name</b>	<b>Project Type</b>	<b>Expected In-Service Date</b>	<b>Project Cost</b>
1	New Delaney-Colorado River 500 kV line <sup>58</sup>	Economic-driven project	2020	\$338 M

<sup>58</sup> The Delaney-Colorado River 500 kV line was not approved by the ISO Board of Governors at the March 20, 2014 ISO Board meeting.

### 7.3 Competitive Solicitation for New Transmission Elements

Phase 3 of the ISO's transmission planning process includes a competitive solicitation process for reliability-driven, policy-driven and economically driven regional transmission facilities. Where the ISO selects a regional transmission solution to meet an identified need in one of the three aforementioned categories that constitutes an upgrade to or addition on an existing participating transmission owner facility, the construction or ownership of facilities on a participating transmission owner's right-of-way, or the construction or ownership of facilities within an existing participating transmission owner's substation, construction and ownership responsibility for the applicable upgrade or addition lies with the applicable participating transmission owner.

The ISO has identified the following regional transmission solutions recommended for approval in this 2013-2014 transmission plan as including transmission facilities that are eligible for competitive solicitation:

- Reliability-driven Projects:
  - o Imperial Valley flow controller (if the back-to-back HVDC convertor is selected as the preferred technology)
  - o Estrella 230/70 kV substation
  - o Wheeler Ridge Junction 230/115 kV substation
  - o Spring 230/115 kV substation near Morgan Hill
  - o Miguel 500 kV voltage support
- Policy-driven Projects
  - o Suncrest SVC
- Economically driven Projects
  - o Delaney-Colorado River 500 kV transmission line<sup>59</sup>

Further, two<sup>60</sup> additional projects may be recommended for approval as part of this plan after additional analysis is performed:

- San Francisco Peninsula reinforcement (reliability-driven)
- Harry Allen-Eldorado 500 kV transmission line (economically driven)

As discussed in Section 2.6.3.2, the selection of technology for the Imperial Valley Flow Controller will require additional coordination with CFE before a final determination can be made as to if the less costly phase shifting transformer will suffice, or if the more expensive back-to-back HVDC converter technology is required. It will be necessary to pursue both solutions recognizing that only one solution will ultimately be selected. The ISO has concluded that the installation of a phase shifting transformer constitutes an upgrade to an existing substation facility due to the nature of the equipment and would therefore not be eligible for the competitive

---

<sup>59</sup> The Delaney-Colorado River 500 kV line was not approved by the ISO Board of Governors at the March 20, 2014 ISO Board meeting.

<sup>60</sup> There are three additional projects that may be recommended for approval as a part of this plan after additional analysis is performed. Further assessment of the Delaney-Colorado River 500 kV line will be undertaken by the ISO as indicated at the March 20, 2014 Board of Governors meeting.

procurement process. The ISO has noted that due to the large number of facilities eligible for competitive solicitation process identified in this plan, that it will be necessary to stage or stagger the receipt and processing of all applications into the competitive solicitation process. The ISO will stage the receipt and consideration of the back-to-back HVDC converter technology (if selected as the preferred technology) towards the end of the staging process.

The facilities in the Estrella, Wheeler Ridge Junction and Spring substation projects that are considered eligible are the 230 kV buswork and termination equipment, and the 230/70 kV or 230/115 kV transformers. The 70 kV and 115 kV buswork and termination equipment are not eligible for competitive solicitation.

The ISO notes that the recommended synchronous condensers at San Luis Rey have not been included for competitive solicitation. The ISO has determined that the physical constraints at San Luis Rey and in the immediate vicinity preclude construction of the synchronous condensers without modifying the existing San Luis Rey substation, and as such is not reasonable or prudent to consider for competitive solicitation.

The descriptions and functional specifications for the facilities eligible for competitive solicitation can be found in Appendix F.

## 7.4 Capital Program Impacts on Transmission High Voltage Access Charge

### 7.4.1 Background

The ISO is continuing to update and enhance its internal tool used to estimate future trends in the High Voltage Transmission Access Charge (HV TAC) to provide an estimation of the impact of the capital projects identified in the 10 Year Transmission Plan on the access charge. This tool was first used in developing results documented in the 2012-2013 transmission plan, and the model itself was released to stakeholders for review and comment in October 2013. Additional upgrades to the model have been made reflecting certain of the comments received from stakeholders.

The final and actual determination of the High Voltage Transmission Access Charge is the result of numerous and extremely complex revenue requirement and cost allocation exercises conducted by the ISO's participating transmission owners, with the costs being subject to FERC regulatory approval before being factored in the determination of a specific HV TAC rate recovered by the ISO from ISO customers. In seeking to provide estimates of the impacts on future access rates, we recognized it was neither helpful nor efficient to attempt to duplicate that modeling in all its detail. Rather, an excessive layer of complexity in the model would make a high level understanding of the relative impacts of different cost drivers more difficult to review and understand. However, the cost components need to be considered in sufficient detail that the relative impacts of different decisions can be reasonably estimated.

The tool is based on the fundamental cost-of-service models employed by the participating transmission owners, with a level of detail necessary to adequately estimate the impacts of changes in capital spending, operating costs, and so forth. Cost calculations included costs associated with existing rate base and operating expenses, and, for new capital costs, tax, return, depreciation, and an operations and maintenance (O&M) component.

The model is not a detailed calculation of any individual participating transmission owner's revenue requirement – parties interested in that information should contact the specific participating transmission owner directly. For example, certain PTOs' existing rate bases were slightly adjusted to “true up” with a single rate of return and tax treatment to the actual initial revenue requirement incorporated into the TAC rate, recognizing that individual capital facilities are not subject to the identical return and tax treatment. This “true up” also accounts for construction funds already spent which the utility has received FERC approval to earn return and interest expense upon prior to the subject facilities being completed.

The tool does not attempt to break out rate impacts by category, e.g. reliability-driven, policy-driven and economically driven categories used by the ISO to develop the comprehensive plan in its structured analysis, or by utility. The ISO is concerned that a breakout by ISO tariff category can create industry confusion, as, for example, a “policy-driven” project may have also addressed the need met by a previously identified reliability-driven project that was subsequently replaced by the broader policy-driven project. While the categorization is appropriately as a “policy-driven” project for transmission planning tariff purposes, it can lead to

misunderstandings of the cost implications of achieving certain policies – as the entire replacement project is attributed to “policy”. Further, certain high level cost assumptions are appropriate on an ISO-wide basis, but not necessarily appropriate to apply to any one specific utility.

#### **7.4.2 Input Assumptions and Analysis**

The ISO’s rate impact model is based on publicly available information or ISO assumptions as set out below, with clarifications provided by several utilities.

Each PTO’s most recent FERC revenue requirement approvals are relied upon for revenue requirement consisting of capital related costs and operating expense requirements, as well as plant and depreciation balances. Single tax and financing structures for each PTO are utilized, which necessitates some adjustments to rate base. These adjustments are “back-calculated” such that each PTO’s total revenue requirement aligned with the filing.

Total existing costs are then adjusted on a going forward basis through escalation of O&M costs, adjustments for capital maintenance costs, and depreciation impacts.

Escalation of O&M costs and capital maintenance are applied on a single basis based on North American industry-wide experience – these have not yet been adjusted to reflect possible local variations from more industry-wide estimated parameters. A 2% escalation of O&M costs was used, and capital maintenance of 2% of gross plant is applied. While these are not precise, and the ISO will seek refinements to the model in future periods, these approximations are considered reasonable to determine a base upon which to assess the impact of the ISO’s capital program on the HV TAC.

The tool accommodates project-specific tax, return, depreciation and Allowances for Funds Used during Construction (AFUDC) treatment information.

In modeling individual projects, it is important to note that some projects have been awarded unique treatment, such as inclusion of Capital Work in Progress (CWIP) in rate base. For certain projects under construction, therefore, the existing high voltage TAC rate already reflects a major portion of the project cost, rather than the impact only being seen upon commissioning of those facilities. For those projects, the capital costs attributed to the “project” entry were for costs that remained to be spent, as the adjusted existing rate base and existing revenue requirement already reflect the costs that have been incurred and are included in rates.

As in past planning cycles, a 1% load growth was assumed in overall energy forecast over which the high voltage transmission revenue requirement is recovered.

The ISO has also started adjusting the long term forecast return on equity assumptions from 12% downward. While stakeholders have suggested that a 10% return may be appropriate, the ISO has considered this as a lower bound, and based this year’s analysis of future transmission projects on a more conservative average of 11% in Figure 7.4-1. This year’s calculations for new transmission facilities were also provided with a 12% assumption to demonstrate the impact of the transition and select a conservative value for illustration purposes. The overall return values for existing rate base assets are drawn from the PTO’s actual approved revenue

requirements. The estimate from the 2012-2013 Transmission Plan has also been provided for comparison.

Figure 7.4-1: Forecast of Capital Project Impact on ISO High Voltage Transmission Access Charge

