

2020 LOCAL CAPACITY TECHNICAL STUDY

DRAFT REPORT AND STUDY RESULTS

Intentionally left blank

Executive Summary

This Report documents the results and recommendations of the 2020 Local Capacity Technical (LCT) Study. The LCT Study assumptions, processes, and criteria were discussed and recommended through the 2020 Local Capacity Technical Study Criteria, Methodology and Assumptions Stakeholder Meeting held on October 31, 2018. On balance, the assumptions, processes, and criteria used for the 2020 LCT Study mirror those used in the 2007-2019 LCT Studies, which were previously discussed and recommended through the LCT Study Advisory Group (“LSAG”)¹, an advisory group formed by the CAISO to assist the CAISO in its preparation for performing prior LCT Studies.

The 2020 LCT study results are provided to the CPUC for consideration in its 2020 resource adequacy requirements program. These results will also be used by the CAISO as “Local Capacity Requirements” or “LCR” (minimum quantity of local capacity necessary to meet the LCR criteria) and for assisting in the allocation of costs of any CAISO procurement of capacity needed to achieve the Reliability Standards notwithstanding the resource adequacy procurement of Load Serving Entities (LSEs).²

The load forecast used in this study is based on the final adopted California Energy Demand Updated Forecast, 2018-2030 developed by the CEC; namely the load-serving entity (LSE) and balancing authority (BA) mid baseline demand with low additional achievable energy efficiency and photo voltaic (AAEE-AAPV), posted on 2/5/2019: <https://efiling.energy.ca.gov/GetDocument.aspx?tn=226462&DocumentContentId=57239>.

To aide procurement, this LCT study provides load profiles and transmission capacity information that shows the effectiveness of local resources in meeting temporal local reliability needs.

Overall, the capacity needed for LCR has decreased by about 961 MW or about 3.9% from 2019 to 2020.

The LCR needs have decreased in the following areas: Humboldt, Big Creek/Ventura and LA Basin due to downward trend for load; Sierra due to transmission projects; San Diego due to unavailability of solar at 8:00 PM and a combination of mitigation measures evaluated.

The LCR needs have increased in North Coast/North Bay, Bay Area, Stockton, Fresno and Kern due to load increase.

The narrative for each Local Capacity Area lists important new projects included in the base cases as well as a description of reason for changes between the 2019 and 2020 LCT study results.

¹ The LSAG consists of a representative cross-section of stakeholders, technically qualified to assess the issues related to the study assumptions, process and criteria of the existing LCT Study methodology and to recommend changes, where needed.

² For information regarding the conditions under which the CAISO may engage in procurement of local capacity and the allocation of the costs of such procurement, please see Sections 41 and 43 of the current CAISO Tariff, at: <http://www.caiso.com/238a/238acd24167f0.html>.

The studied results for 2020 are provided below and 2024 LCR needs are provided for comparison:

2020 Local Capacity Needs

Local Area Name	Qualifying Capacity				Capacity Available at Peak	2020 LCR Need Category B	2020 LCR Need Category C
	QF/ Muni (MW)	Non-Solar (MW)	Solar (MW)	Total (MW)	Total (MW)	Capacity Needed	Capacity Needed
Humboldt	0	197	0	197	197	83	130
North Coast/ North Bay	117	715	1	833	832	742	742
Sierra	1168	986	6	2160	2154	1091	1764*
Stockton	155	497	1	653	652	603*	629*
Greater Bay	617	6438	12	7067	7067	3970	4550
Greater Fresno	222	2583	372	3177	2770	1694	1694*
Kern	8	354	103	465	362	169*	465*
Big Creek/ Ventura	405	4389	305	5099	5099	2154	2410*
LA Basin	1344	9078	17	10439	10104	7364	7364
San Diego/ Imperial Valley	4	3891	439	4334	3895	3895	3895
Total	4040	29128	1256	34424	33132	21765	23643

2024 Local Capacity Needs

Local Area Name	Qualifying Capacity				Capacity Available at Peak	2024 LCR Need Category B	2024 LCR Need Category C
	QF/ Muni (MW)	Non-Solar (MW)	Solar (MW)	Total (MW)	Total (MW)	Capacity Needed	Capacity Needed
Humboldt	0	197	0	197	197	83	132
North Coast/ North Bay	118	715	1	833	832	706	706
Sierra	1168	986	6	2160	2154	788	1304
Stockton	137	680	1	699	698	388*	675*
Greater Bay	617	7011	12	7640	7640	3494	4395
Greater Fresno	222	2733	393	3348	2920	1711	1711*
Kern	8	354	103	465	362	0	152*
Big Creek/ Ventura	402	2821	305	3528	3528	2083*	2577*
LA Basin	1344	7038	17	8399	8399	6224	6260
San Diego/ Imperial Valley	4	4032	523	4559	4036	4025	4025
Total	4020	26567	1361	31828	30766	19502	21937

* No local area is "overall deficient". Details about magnitude of deficiencies can be found in the applicable section below. Resource deficient sub-area implies that in order to comply with the criteria, at summer peak, load may be shed immediately after the first contingency.

The estimated results for years 2021 and 2022 LCR needs are provided below:

2021 Estimated Local Capacity Needs (To be completed in final report)

Local Area Name	Qualifying Capacity				Capacity Available at Peak	2021 LCR Need Category B	2021 LCR Need Category C
	QF/ Muni (MW)	Non-Solar (MW)	Solar (MW)	Total (MW)	Total (MW)	Capacity Needed	Capacity Needed
Humboldt							
North Coast/ North Bay							
Sierra							
Stockton							
Greater Bay							
Greater Fresno							
Kern							
Big Creek/ Ventura							
LA Basin							
San Diego/ Imperial Valley							
Total							

2022 Estimated Local Capacity Needs (To be completed in final report)

Local Area Name	Qualifying Capacity				Capacity Available at Peak	2022 LCR Need Category B	2022 LCR Need Category C
	QF/ Muni (MW)	Non-Solar (MW)	Solar (MW)	Total (MW)	Total (MW)	Capacity Needed	Capacity Needed
Humboldt							
North Coast/ North Bay							
Sierra							
Stockton							
Greater Bay							
Greater Fresno							
Kern							
Big Creek/ Ventura							
LA Basin							
San Diego/ Imperial Valley							
Total							

* No local area is “overall deficient”. Details about magnitude of deficiencies can be found in the applicable section below. Resource deficient sub-area implies that in order to comply with the criteria, at summer peak, load may be shed immediately after the first contingency.

The studied results for year 2019 LCR needs are provided below for comparison:

2019 Local Capacity Needs

Local Area Name	Qualifying Capacity			2019 LCR Need Based on Category B			2019 LCR Need Based on Category C with operating procedure		
	QF/ Muni (MW)	Market (MW)	Total (MW)	Existing Capacity Needed	Deficiency	Total (MW)	Existing Capacity Needed**	Deficiency	Total (MW)
Humboldt	0	202	202	116	0	116	165	0	165
North Coast/ North Bay	119	771	890	689	0	689	689	0	689
Sierra	1146	1004	2150	1362	0	1362	1964	283*	2247
Stockton	144	489	633	405	5*	410	427	350*	777
Greater Bay	628	6426	7054	3670	0	3670	4461	0	4461
Greater Fresno	340	3098	3438	1406	0	1406	1670	1*	1671
Kern	13	462	475	148	6*	154	472	6*	478
LA Basin	1445	8780	10225	7968	0	7968	8116	0	8116
Big Creek/Ventura	424	4649	5073	2333	0	2333	2614	0	2614
San Diego/ Imperial Valley	106	4252	4358	4026	0	4026	4026	0	4026
Total	4365	30133	34498	22123	11	22134	24604	640	25244

* No local area is "overall deficient". Resource deficiency values result from a few deficient sub-areas; and since there are no resources that can mitigate this deficiency the numbers are carried forward into the total area needs. Resource deficient sub-area implies that in order to comply with the criteria, at summer peak, load may be shed immediately after the first contingency.

** Since "deficiency" cannot be mitigated by any available resource, the "Existing Capacity Needed" will be split among LSEs on a load share ratio during the assignment of local area resource responsibility.

The narrative for each Local Capacity Area lists important new projects included in the base cases as well as a description of reason for changes between the 2019 and 2020 LCT study results.

Intentionally left blank

Table of Contents

Executive Summary	1
1 Overview of the Study: Inputs, Outputs and Options.....	8
1.1 Objectives	8
1.2 Key Study Assumptions	8
1.2.1 Inputs, Assumptions and Methodology	8
1.3 Grid Reliability	10
1.4 Application of N-1, N-1-1, and N-2 Criteria	10
1.5 Performance Criteria	11
1.5.1 Performance Criteria- Category B.....	11
1.5.2 Performance Criteria- Category C	11
1.5.3 CAISO Statutory Obligation Regarding Safe Operation	12
1.6 The Two Options Presented In This LCT Study Report	15
1.6.1 Option 1 - Meet Performance Criteria Category B	15
1.6.2 Option 2 - Meet Performance Criteria Category C and Incorporate Suitable Operational Solutions	16
2 Assumption Details: How the Study was Conducted.....	17
2.1 System Planning Criteria.....	17
2.1.1 Power Flow Assessment:	18
2.1.2 Post Transient Load Flow Assessment:.....	19
2.1.3 Stability Assessment:	19
2.1.4 Engineering Estimate for Intermediate Years:	19
2.2 Load Forecast	21
2.2.1 System Forecast	21
2.2.2 Base Case Load Development Method	21
2.3 Power Flow Program Used in the LCR analysis	22
3 Locational Capacity Requirement Study Results	24
3.1 Summary of Study Results	24
3.2 Summary of Zonal Needs.....	25
3.3 Summary of Results by Local Area	27
3.3.1 Humboldt Area	27
3.3.2 North Coast / North Bay Area	30
3.3.3 Sierra Area	41
3.3.4 Stockton Area.....	61
3.3.5 Greater Bay Area	75
3.3.6 Greater Fresno Area	100
3.3.7 Kern Area	120
3.3.8 Big Creek/Ventura Area.....	133
3.3.9 LA Basin Area	142
3.3.10 San Diego-Imperial Valley Area.....	153
3.3.11 Valley Electric Area	170
Attachment A – List of physical resources by PTO, local area and market ID	171
Attachment B – Effectiveness factors for procurement guidance.....	215

Intentionally left blank

1 Overview of the Study: Inputs, Outputs and Options

1.1 Objectives

The intent of the 2020 LCT Study is to identify specific areas within the CAISO Balancing Authority Area that have limited import capability and determine the minimum generation capacity (MW) necessary to mitigate the local reliability problems in those areas, as was the objective of all previous Local Capacity Technical Studies.

To aide procurement, this LCT study provides load profiles and transmission capacity information that shows the effectiveness of local resources in meeting temporal local reliability needs.

1.2 Key Study Assumptions

1.2.1 Inputs, Assumptions and Methodology

The inputs, assumptions and methodology were discussed and agreed to by stakeholders at the 2020 LCT Study Criteria, Methodology and Assumptions Stakeholder Meeting held on October 31, 2018. They are similar to those used and incorporated in previous LCT studies. The following table sets forth a summary of the approved inputs and methodology that have been used in this 2020 LCT Study:

Table 1.2-1 Summary Table of Inputs and Methodology Used in this LCT Study:

Issue	How Incorporated into this LCT Study:
Input Assumptions:	
Transmission System Configuration	The existing transmission system has been modeled, including all projects operational on or before June 1, of the study year and all other feasible operational solutions brought forth by the PTOs and as agreed to by the CAISO.
Generation Modeled	The existing generation resources has been modeled and also includes all projects that will be on-line and commercial on or before June 1, of the study year
Load Forecast	Uses a 1-in-10 year summer peak load forecast
Methodology:	

Maximize Import Capability	Import capability into the load pocket has been maximized, thus minimizing the generation required in the load pocket to meet applicable reliability requirements.
QF/Nuclear/State/Federal Units	Regulatory Must-take and similarly situated units like QF/Nuclear/State/Federal resources have been modeled on-line at qualifying capacity output values for purposes of this LCT Study.
Maintaining Path Flows	Path flows have been maintained below all established path ratings into the load pockets, including the 500 kV. For clarification, given the existing transmission system configuration, the only 500 kV path that flows directly into a load pocket and will, therefore, be considered in this LCT Study is the South of Lugo transfer path flowing into the LA Basin.
Performance Criteria:	
Performance Level B & C, including incorporation of PTO operational solutions	This LCT Study is being published based on Performance Level B and Performance Level C criterion, yielding the low and high range LCR scenarios. In addition, the CAISO will incorporate all new projects and other feasible and CAISO-approved operational solutions brought forth by the PTOs that can be operational on or before June 1, of the study year. Any such solutions that can reduce the need for procurement to meet the Performance Level C criteria will be incorporated into the LCT Study.
Load Pocket:	
Fixed Boundary, including limited reference to published effectiveness factors	This LCT Study has been produced based on load pockets defined by a fixed boundary. The CAISO only publishes effectiveness factors where they are useful in facilitating procurement where excess capacity exists within a load pocket.

Further details regarding the 2020 LCT Study methodology and assumptions are provided in Section III, below.

1.3 Grid Reliability

Service reliability builds from grid reliability because grid reliability is reflected in the Reliability Standards of the North American Electric Reliability Council (NERC) and the Western Electricity Coordinating Council (“WECC”) Regional Criteria (collectively “Reliability Standards”). The Reliability Standards apply to the interconnected electric system in the United States and are intended to address the reality that within an integrated network, whatever one Balancing Authority Area does can affect the reliability of other Balancing Authority Areas. Consistent with the mandatory nature of the Reliability Standards, the CAISO is under a statutory obligation to ensure efficient use and reliable operation of the transmission grid consistent with achievement of the Reliability Standards.³ The CAISO is further under an obligation, pursuant to its FERC-approved Transmission Control Agreement, to secure compliance with all “Applicable Reliability Criteria.” Applicable Reliability Criteria consists of the Reliability Standards as well as reliability criteria adopted by the CAISO (Grid Planning Standards).

The Reliability Standards define reliability on interconnected electric systems using the terms “adequacy” and “security.” “Adequacy” is the ability of the electric systems to supply the aggregate electrical demand and energy requirements of their customers at all times, taking into account physical characteristics of the transmission system such as transmission ratings and scheduled and reasonably expected unscheduled outages of system elements. “Security” is the ability of the electric systems to withstand sudden disturbances such as electric short circuits or unanticipated loss of system elements. The Reliability Standards are organized by Performance Categories. Certain categories require that the grid operator not only ensure that grid integrity is maintained under certain adverse system conditions (e.g., security), but also that all customers continue to receive electric supply to meet demand (e.g., adequacy). In that case, grid reliability and service reliability would overlap. But there are other levels of performance where security can be maintained without ensuring adequacy.

1.4 Application of N-1, N-1-1, and N-2 Criteria

The CAISO will maintain the system in a safe operating mode at all times. This obligation translates into respecting the Reliability Criteria at all times, for example during normal operating conditions (N-0) the CAISO must protect for all single contingencies (N-1) and common mode (N-2) double line outages. Also, after a single contingency, the CAISO must re-adjust the system to support the loss of the next most stringent contingency. This is referred to as the N-1-1 condition.

The N-1-1 vs N-2 terminology was introduced only as a temporal differentiation between two existing⁴ NERC Category C events. N-1-1 represents NERC Category C3 (“category B contingency, manual system adjustment, followed by another category B contingency”). The N-2 represents NERC Category C5 (“any two circuits of a multiple circuit tower line”) as well as WECC-

³ Pub. Utilities Code § 345

⁴ NERC Category B and C terminology no longer aligns with the current NERC standards. It is used in this report since the ISO Tariff still uses this terminology that was in effect at the time when the ISO Tariff section was written.

S2 (for 500 kV only) (“any two circuits in the same right-of-way”) with no manual system adjustment between the two contingencies.

1.5 Performance Criteria

As set forth on the Summary Table of Inputs and Methodology, this LCR Report is based on NERC Performance Level B and Performance Level C criterion. The NERC Standards refer mainly to thermal overloads. However, the CAISO also tests the electric system in regards to the dynamic and reactive margin compliance with the existing WECC standards for the same NERC performance levels. These Performance Levels can be described as follows:

1.5.1 Performance Criteria- Category B

Category B describes the system performance that is expected immediately following the loss of a single transmission element, such as a transmission circuit, a generator, or a transformer.

Category B system performance requires that all thermal and voltage limits must be within their “Applicable Rating,” which, in this case, are the emergency ratings as generally determined by the PTO or facility owner. Applicable Rating includes a temporal element such that emergency ratings can only be maintained for certain duration. Under this category, load cannot be shed in order to assure the Applicable Ratings are met however there is no guarantee that facilities are returned to within normal ratings or to a state where it is safe to continue to operate the system in a reliable manner such that the next element out will not cause a violation of the Applicable Ratings.

1.5.2 Performance Criteria- Category C

The NERC Planning Standards require system operators to “look forward” to make sure they safely prepare for the “next” N-1 following the loss of the “first” N-1 (stay within Applicable Ratings after the “next” N-1). This is commonly referred to as N-1-1. Because it is assumed that some time exists between the “first” and “next” element losses, operating personnel may make any reasonable and feasible adjustments to the system to prepare for the loss of the second element, including, operating procedures, dispatching generation, moving load from one substation to another to reduce equipment loading, dispatching operating personnel to specific station locations to manually adjust load from the substation site, or installing a “Special Protection Scheme” that would remove pre-identified load from service upon the loss of the “next “ element.⁵ All Category C requirements in this report refer to situations when in real time (N-0) or after the first contingency

⁵ A Special Protection Scheme is typically proposed as an operational solution that does not require additional generation and permits operators to effectively prepare for the next event as well as ensure security should the next event occur. However, these systems have their own risks, which limit the extent to which they could be deployed as a solution for grid reliability augmentation. While they provide the value of protecting against the next event without the need for pre-contingency load shedding, they add points of potential failure to the transmission network. This increases the potential for load interruptions because sometimes these systems will operate when not required and other times they will not operate when needed.

(N-1) the system requires additional readjustment in order to prepare for the next worst contingency. In this time frame, load drop is not allowed per existing planning criteria.

Generally, Category C describes system performance that is expected following the loss of two or more system elements. This loss of two elements is generally expected to happen simultaneously, referred to as N-2. It should be noted that once the “next” element is lost after the first contingency, as discussed above under the Performance Criteria B, N-1-1 scenario, the event is effectively a Category C. As noted above, depending on system design and expected system impacts, the **planned and controlled** interruption of supply to customers (load shedding), the removal from service of certain generators and curtailment of exports may be utilized to maintain grid “security.”

1.5.3 CAISO Statutory Obligation Regarding Safe Operation

The CAISO will maintain the system in a safe operating mode at all times. This obligation translates into respecting the Reliability Criteria at all times, for example during normal operating conditions **A (N-0)** the CAISO must protect for all single contingencies **B (N-1)** and common mode **C5 (N-2)** double line outages. As a further example, after a single contingency the CAISO must readjust the system in order to be able to support the loss of the next most stringent contingency **C3 (N-1-1)**.

Figure 1.5-1 Temporal graph of LCR Category B vs. LCR Category C

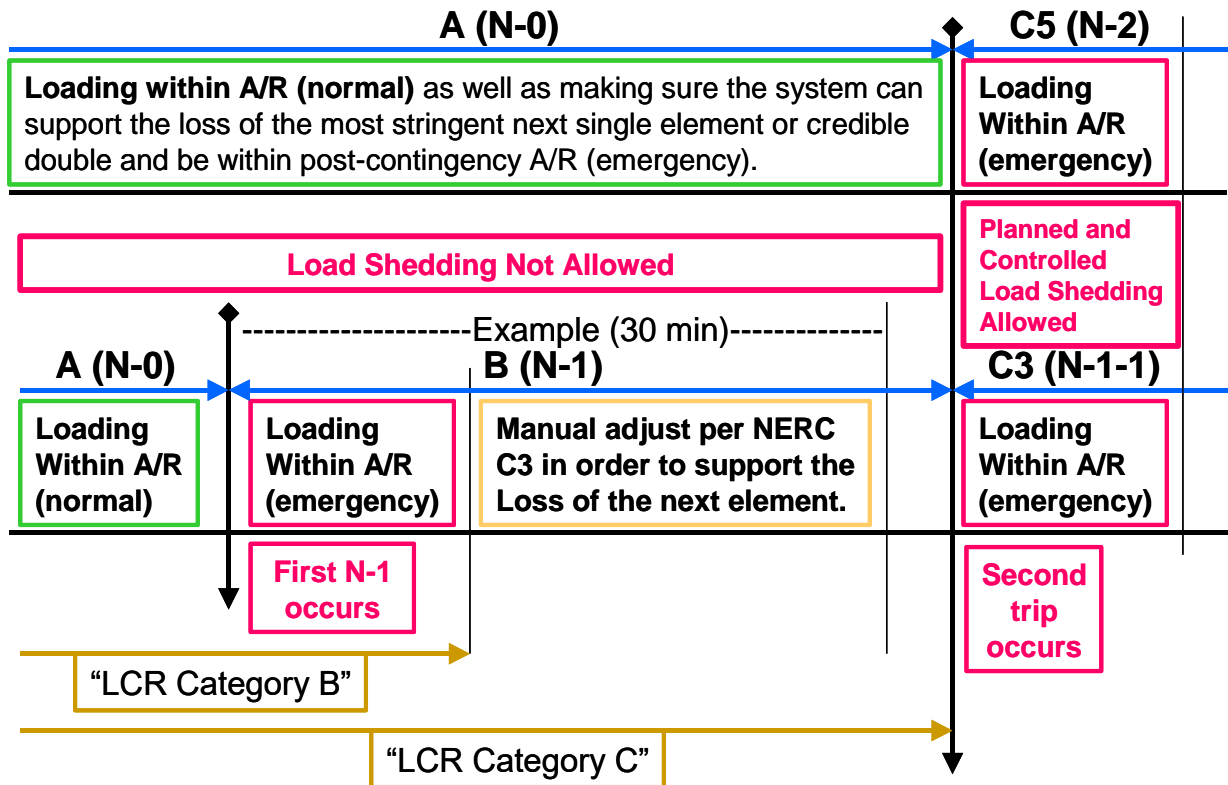

The following definitions guide the CAISO's interpretation of the Reliability Criteria governing safe mode operation and are used in this LCT Study:

Applicable Rating:

This represents the equipment rating that will be used under certain contingency conditions.

Normal rating is to be used under normal conditions.

Long-term emergency ratings, if available, will be used in all emergency conditions as long as "system readjustment" is provided in the amount of time given (specific to each element) to reduce the flow to within the normal ratings. If not available, the normal rating is to be used.

Short-term emergency ratings, if available, can be used as long as "system readjustment" is provided in the "short-time" available in order to reduce the flow to within the long-term emergency ratings where the element can be kept for another length of time (specific to each element) before the flow needs to be reduced the below the normal ratings. If not available long-term emergency rating should be used.

Temperature-adjusted ratings shall not be used because this is a year-ahead study, not a real-time tool, and as such the worst-case scenario must be covered. In case temperature-adjusted ratings are the only ratings available then the minimum rating (highest temperature) given the study conditions shall be used.

CAISO Transmission Register is the only official keeper of all existing ratings mentioned above.

Ratings for future projects provided by PTO and agreed upon by the CAISO shall be used.

Other short-term ratings not included in the CAISO Transmission Register may be used as long as they are engineered, studied and enforced through clear operating procedures that can be followed by real-time operators.

Path Ratings need to be maintained within their limits in order to assure that proper capacity is available in order to operate the system in real-time in a safe operating zone.

Controlled load drop:

This is achieved with the use of a Special Protection Scheme.

Planned load drop:

This is achieved when the most limiting equipment has short-term emergency ratings AND the operators have an operating procedure that clearly describes the actions that need to be taken in order to shed load.

Special Protection Scheme:

All known SPS shall be assumed. New SPS must be verified and approved by the CAISO and must comply with the new SPS guideline described in the CAISO Planning Standards.

System Readjustment:

This represents the actions taken by operators in order to bring the system within a safe operating zone after any given contingency in the system.

Actions that can be taken as system readjustment after a single contingency (Category B):

1. System configuration change – based on validated and approved operating procedures
2. Generation re-dispatch
 - a. Decrease generation (up to 1150 MW) – limit given by single contingency SPS as part of the CAISO Grid Planning standards (ISO G4)
 - b. Increase generation – this generation will become part of the LCR need

Actions, which shall not be taken as system readjustment after a single contingency (Category B):

1. Load drop – based on the intent of the CAISO/WECC and NERC criteria for category B contingencies.

The NERC Transmission Planning Standards footnote mentions that load shedding can be done after a category B event in certain local areas in order to maintain compliance with performance criteria. However, the main body of the criteria spells out that no dropping of load should be done following a single contingency. All stakeholders and the CAISO agree that no involuntary interruption of load should be done immediately after a single contingency. Further, the CAISO and stakeholders now agree on the viability of dropping load as part of the system readjustment period – in order to protect for the next most limiting contingency. After a single contingency, it is understood that the system is in a Category B condition and the system should be planned based on the body of the criteria with no shedding of load regardless of whether it is done immediately or in 15-30 minute after the original contingency. Category C conditions only arrive after the second contingency has happened; at that point in time, shedding load is allowed in a planned and controlled manner.

A robust California transmission system should be, and under the LCT Study is being, planned based on the main body of the criteria, not the footnote regarding Category B contingencies. Therefore, if there are available resources in the area, they are looked to meet reliability needs (and included in the LCR requirement) before resorting to involuntary load curtailment. The footnote may be applied for criteria compliance issues only where there are no resources available in the area.

Time allowed for manual readjustment:

Tariff Section 40.3.1.1, requires the CAISO, in performing the Local Capacity Technical Study, to apply the following reliability criterion:

Time Allowed for Manual Adjustment: This is the amount of time required for the Operator to take all actions necessary to prepare the system for the next Contingency. The time should not be more than thirty (30) minutes.

The CAISO Planning Standards also impose this manual readjustment requirement. As a parameter of the Local Capacity Technical Study, the CAISO must assume that as the system operator the CAISO will have sufficient time to:

- (1) make an informed assessment of system conditions after a contingency has occurred;
- (2) identify available resources and make prudent decisions about the most effective system redispatch;
- (3) manually readjust the system within safe operating limits after a first contingency to be prepared for the next contingency; and
- (4) allow sufficient time for resources to ramp and respond according to the operator's redispatch instructions. This all must be accomplished within 30 minutes.

Local capacity resources can meet this requirement by either (1) responding with sufficient speed, allowing the operator the necessary time to assess and redispatch resources to effectively reposition the system within 30 minutes after the first contingency, or (2) have sufficient energy available for frequent dispatch on a pre-contingency basis to ensure the operator can meet minimum online commitment constraints or reposition the system within 30 minutes after the first contingency occurs. Accordingly, when evaluating resources that satisfy the requirements of the CAISO Local Capacity Technical Study, the CAISO assumes that local capacity resources need to be available in no longer than 20 minutes so the CAISO and demand response providers have a reasonable opportunity to perform their respective and necessary tasks and enable the CAISO to reposition the system within the 30 minutes in accordance with applicable reliability criteria.

1.6 The Two Options Presented In This LCT Study Report

This LCT Study sets forth different solution “options” with varying ranges of potential service reliability consistent with CAISO’s Reliability Criteria. The CAISO applies Option 2 for its purposes of identifying necessary local capacity needs and the corresponding potential scope of its backstop authority. Nevertheless, the CAISO continues to provide Option 1 as a point of reference for the CPUC and Local Regulatory Authorities in considering procurement targets for their jurisdictional LSEs.

1.6.1 Option 1 - Meet Performance Criteria Category B

Option 1 is a service reliability level that reflects generation capacity that must be available to comply with reliability standards immediately after a NERC Category B given that load cannot be removed to meet this performance standard under Reliability Criteria. However, this capacity amount implicitly relies on load interruption as the **only means** of meeting any Reliability Criteria

that is beyond the loss of a single transmission element (N-1). These situations will likely require substantial load interruptions in order to maintain system continuity and alleviate equipment overloads prior to the actual occurrence of the second contingency.⁶

1.6.2 Option 2 - Meet Performance Criteria Category C and Incorporate Suitable Operational Solutions

Option 2 is a service reliability level that reflects generation capacity that is needed to readjust the system to prepare for the loss of a second transmission element (N-1-1) using generation capacity *after* considering all reasonable and feasible operating solutions (including those involving customer load interruption) developed and approved by the CAISO, in consultation with the PTOs. Under this option, there is no expected load interruption to end-use customers under normal or single contingency conditions as the CAISO operators prepare for the second contingency. However, the customer load may be interrupted in the event the second contingency occurs.

As noted, Option 2 is the local capacity level that the CAISO requires to reliably operate the grid per NERC, WECC and CAISO standards. As such, the CAISO recommends continuing the adoption of this Option to guide resource adequacy procurement.

⁶ This potential for pre-contingency load shedding also occurs because real time operators must prepare for the loss of a common mode N-2 at all times.

2 Assumption Details: How the Study was Conducted

2.1 System Planning Criteria

The following table provides a comparison of system planning criteria, based on the NERC performance standards, used in the study:

Table 2.1-1: Criteria Comparison

Contingency Component(s)	ISO Grid Planning Criteria	Old RMR Criteria	Local Capacity Criteria
<u>A – No Contingencies</u>	X	X	X
<u>B – Loss of a single element</u>			
1. Generator (G-1)	X	X ¹	X ¹
2. Transmission Circuit (L-1)	X	X	X ¹
3. Transformer (T-1)	X	X ²	X ^{1,2}
4. Single Pole (dc) Line	X	X	X ¹
5. G-1 system readjusted L-1	X	X	X
<u>C – Loss of two or more elements</u>			
1. Bus Section	X		
2. Breaker (failure or internal fault)	X		X
3. L-1 system readjusted G-1	X		X
3. G-1 system readjusted T-1 or T-1 system readjusted G-1	X		X
3. L-1 system readjusted T-1 or T-1 system readjusted L-1	X		X
3. G-1 system readjusted G-1	X		X
3. L-1 system readjusted L-1	X		X
3. T-1 system readjusted T-1	X		X
4. Bipolar (dc) Line	X		
5. Two circuits (Common Mode) L-2	X		
6. SLG fault (stuck breaker or protection failure) for G-1	X		
7. SLG fault (stuck breaker or protection failure) for L-1	X		
8. SLG fault (stuck breaker or protection failure) for T-1	X		X
9. SLG fault (stuck breaker or protection failure) for Bus section	X		
WECC-S3. Two generators (Common Mode) G-2	X ³		
<u>D – Extreme event – loss of two or more elements</u>			
Any B1-4 system readjusted (Common Mode) L-2	X ⁴		X ³
All other extreme combinations D1-14.	X ⁴		
¹ System must be able to readjust to a safe operating zone in order to be able to support the loss of the next contingency. ² A thermal or voltage criterion violation resulting from a transformer outage may not be cause for a local area reliability requirement if the violation is considered marginal (e.g. acceptable loss of facility life or low voltage), otherwise, such a violation will necessitate creation of a requirement. ³ Evaluate for risks and consequence, per NERC standards. No voltage collapse or dynamic instability allowed. ⁴ Evaluate for risks and consequence, per NERC standards.			

A significant number of simulations were run to determine the most critical contingencies within each Local Capacity Area. Using power flow, post-transient load flow, and stability assessment tools, the system performance results of all the contingencies that were studied were measured against the system performance requirements defined by the criteria shown below. Where the specific system performance requirements were not met, generation was adjusted such that the minimum amount of generation required to meet the criteria was determined in the Local Capacity Area. The following describes how the criteria were tested for the specific type of analysis performed.

2.1.1 Power Flow Assessment:

Table 2.1-2 Power flow criteria

Contingencies	Thermal Criteria ³	Voltage Criteria ⁴
Generating unit ^{1,6}	Applicable Rating	Applicable Rating
Transmission line ^{1,6}	Applicable Rating	Applicable Rating
Transformer ^{1,6}	Applicable Rating ⁵	Applicable Rating ⁵
(G-1)(L-1) ^{2,6}	Applicable Rating	Applicable Rating
Overlapping ^{6,7}	Applicable Rating	Applicable Rating

- ¹ All single contingency outages (i.e. generating unit, transmission line or transformer) will be simulated on Participating Transmission Owners' local area systems.
- ² Key generating unit out, system readjusted, followed by a line outage. This over-lapping outage is considered a single contingency within the ISO Grid Planning Criteria. Therefore, load dropping for an overlapping G-1, L-1 scenario is not permitted.
- ³ Applicable Rating – Based on CAISO Transmission Register or facility upgrade plans including established Path ratings.
- ⁴ Applicable Rating – CAISO Grid Planning Criteria or facility owner criteria as appropriate including established Path ratings.
- ⁵ A thermal or voltage criterion violation resulting from a transformer outage may not be cause for a local area reliability requirement if the violation is considered marginal (e.g. acceptable loss of facility life or low voltage), otherwise, such a violation will necessitate creation of a requirement.
- ⁶ Following the first contingency (N-1), the generation must be sufficient to allow the operators to bring the system back to within acceptable (normal) operating range (voltage and loading) and/or appropriate OTC following the studied outage conditions.
- ⁷ During normal operation or following the first contingency (N-1), the generation must be sufficient to allow the operators to prepare for the next worst N-1 or common mode N-2

without pre-contingency interruptible or firm load shedding. SPS/RAS/Safety Nets may be utilized to satisfy the criteria after the second N-1 or common mode N-2 except if the problem is of a thermal nature such that short-term ratings could be utilized to provide the operators time to shed either interruptible or firm load. T-2s (two transformer bank outages) would be excluded from the criteria.

2.1.2 Post Transient Load Flow Assessment:

Table 2.1-3 Post transient load flow criteria

Contingencies	Reactive Margin Criteria ²
Selected ¹	Applicable Rating

- ¹ If power flow results indicate significant low voltages for a given power flow contingency, simulate that outage using the post transient load flow program. The post-transient assessment will develop appropriate Q/V and/or P/V curves.
- ² Applicable Rating – positive margin based on the higher of imports or load increase by 5% for N-1 contingencies, and 2.5% for N-2 contingencies.

2.1.3 Stability Assessment:

Table 2.1-4 Stability criteria

Contingencies	Stability Criteria ²
Selected ¹	Applicable Rating

- ¹ Base on historical information, engineering judgment and/or if power flow or post transient study results indicate significant low voltages or marginal reactive margin for a given contingency.
- ² Applicable Rating – CAISO Grid Planning Criteria or facility owner criteria as appropriate.

2.1.4 Engineering Estimate for Intermediate Years:

Due to combined CEC/CPUC/ISO timelines required by the RA process, the ISO must estimate LCR requirement for intermediate years, between the technical studies run for years one and five.

ISO will be using an engineering estimate for intermediate years. Elements of the engineering judgement estimates are described below:

2.1.4.1 Net Peak Load Growth driven estimate

Assuming nothing else changes, no transmission or resource mix changes, including no changes to long-term contractual arrangements, the increase (or decrease) in LCR, assuming a linear

function, will be estimated based on ratio of load growth to ratio of LCR needs to be multiplied by the number of years using the following formula:

$$\text{LCR for Year of Need} = \text{Year 1 LCR} + [(\text{Year 5 LCR} - \text{Year 1 LCR})/4] \times (\text{Year of Need} - \text{Year 1})$$

For non-linear functions, like voltage collapse or dynamic instability, ISO will use engineering judgment in order to provide estimated LCR requirement.

2.1.4.2 *Single New Transmission driven estimate*

Assuming nothing else changes, no load growth, no other new transmission projects or resource mix changes, including no changes to long-term contractual arrangements, the increase (or decrease in LCR) will be estimated based on a step function (usually decreasing the LCR needs) in the year when the transmission project is supposed to be first operational (if in-service before June 1-st of estimated year for summer peaking areas).

2.1.4.3 *Single New Resource driven estimate*

Assuming nothing else changes, no load growth, no new transmission projects or any other resource mix changes, including no changes to long-term contractual arrangements, the increase (or decrease in LCR) will be estimated based on a step function if:

- a) The new resource is catalogued with a higher dispatch priority or the same priority as the marginal resource used for establishment of LCR need AND
- b) The new resource has a significantly different (10% or more) effectiveness factor difference vs. the marginal resource used for the establishment of the LCR need.

Priority dispatch order (from LCR study manual):

1. QF/MUNI/State/Federal
2. RA resources under long-term contracts
3. Unknown contractual status

2.1.4.4 *Single Change in Resource contractual status driven estimate*

Assuming nothing else changes, no load growth, no new transmission projects or resource mix changes, including no changes to other long-term contractual arrangements, the increase (or decrease in LCR) will be estimated based on a step function if:

- a) The resource is moving to a higher dispatch priority or the same priority as the marginal resource used for establishment of LCR need AND
- b) The resource has a significantly different (10% or more) effectiveness factor difference vs. the marginal resource used for the establishment of the LCR need.

2.1.4.5 *Single Known Resource Retirement driven estimate*

Assuming nothing else changes, no load growth, no new transmission projects or other resource mix changes, including no changes to long-term contractual arrangements, the increase (or decrease in LCR) will be estimated based on a step function if:

- a) The retired resource was included in a higher dispatch priority or the same priority as the marginal resource used for establishment of LCR need AND
- b) The resource has a significantly different (10% or more) effectiveness factor difference vs. the marginal resource used for the establishment of the LCR need.

2.1.4.6 **Multi Reason Change driven estimate**

From multi-year available LCR studies the ISO will use engineering judgement, guided by the above explain single change principles, in order to estimate intermediate year LCR needs any time more than one factor is influencing the LCR results:

- a) Net peak load growth
- b) New transmission project(s)
- c) New resource(s)
- d) Change in resource contractual status
- e) Known resource retirement(s)

2.2 Load Forecast

2.2.1 System Forecast

The California Energy Commission (CEC) derives the load forecast at the system and Participating Transmission Owner (PTO) levels. This relevant CEC forecast is then distributed across the entire system, down to the local area, division and substation level. The PTOs use an econometric equation to forecast the system load. The predominant parameters affecting the system load are (1) number of households, (2) economic activity (gross metropolitan products, GMP), (3) temperature and (4) increased energy efficiency and distributed generation programs.

2.2.2 Base Case Load Development Method

The method used to develop the load in the base case is a melding process that extracts, adjusts and modifies the information from the system, distribution and municipal utility forecasts. The melding process consists of two parts: Part 1 deals with the PTO load and Part 2 deals with the municipal utility load. There may be small differences between the methodologies used by each PTO to disaggregate the CEC load forecast to their level of local area as well as bar-bus model.

2.2.2.1 PTO Loads in Base Case

The methods used to determine the PTO loads are, for the most part, similar. One part of the method deals with the determination of the division⁷ loads that would meet the requirements of 1-

⁷ Each PTO divides its territory in a number of smaller area named divisions. These are usually smaller and compact areas that have the same temperature profile.

in-5 or 1-in-10 system or area base cases and the other part deals with the allocation of the division load to the transmission buses.

a. Determination of division loads

The annual division load is determined by summing the previous year division load and the current division load growth. Thus, the key steps are the determination of the initial year division load and the annual load growth. The initial year for the base case development method is based heavily on recorded data. The division load growth in the system base case is determined in two steps. First, the total PTO load growth for the year is determined, as the product of the PTO load and the load growth rate from the system load forecast. Then this total PTO load growth is allocated to the division, based on the relative magnitude of the load growth projected for the divisions by the distribution planners. For example, for the 1-in-10 area base case, the division load growth determined for the system base case is adjusted to the 1-in-10 temperature using the load temperature relation determined from the latest peak load and temperature data of the division.

b. Allocation of division load to transmission bus level

Since the loads in the base case are modeled at the various transmission buses, the division loads developed must be allocated to those buses. The allocation process is different depending on the load types. For the most part, each PTO classifies its loads into four types: conforming, non-conforming, self-generation and generation-plant loads. Since the non-conforming and self-generation loads are assumed to not vary with temperature, their magnitude would be the same in the system or area base cases of the same year. The remaining load (the total division load developed above, less the quantity of non-conforming and self-generation load) is the conforming load. The remaining load is allocated to the transmission buses based on the relative magnitude of the distribution forecast. The summation of all base case loads is generally higher than the load forecast because some load, i.e., self-generation and generation-plant, are behind the meter and must be modeled in the base cases. However, for the most part, metered or aggregated data with telemetry is used to come up with the load forecast.

2.2.2.2 *Municipal Loads in Base Case*

The municipal utility forecasts that have been provided to the CEC and PTOs for the purposes of their base cases were also used for this study.

2.3 Power Flow Program Used in the LCR analysis

The technical studies were conducted using General Electric's Power System Load Flow (GE PSLF) program version 21.0_05 and PowerGem's Transmission Adequacy and Reliability Assessment (TARA) program version 1702. This GE PSLF program is available directly from GE or through the Western System Electricity Council (WECC) to any member and TARA program is commercially available.

To evaluate Local Capacity Areas, the starting base case was adjusted to reflect the latest generation and transmission projects as well as the one-in-ten-year peak load forecast for each Local Capacity Area as provided to the CAISO by the PTOs.

Electronic contingency files provided by the PTOs were utilized to perform the numerous contingencies required to identify the LCR. These contingency files include remedial action and special protection schemes that are expected to be in operation during the year of study. A CAISO created EPCL (a GE programming language contained within the GE PSLF package) routine and/or TARA software were used to run the combination of contingencies; however, other routines are available from WECC with the GE PSLF package or can be developed by third parties to identify the most limiting combination of contingencies requiring the highest amount of generation within the local area to maintain power flows within applicable ratings.

3 Locational Capacity Requirement Study Results

3.1 Summary of Study Results

LCR is defined as the amount of resource capacity that is needed within a Local Capacity Area to reliably serve the load located within this area. The results of the CAISO's analysis are summarized in the Executive Summary Tables.

Table 3.1-1 2020 Local Capacity Needs vs. Peak Load and Local Area Resources

	2020 Total LCR (MW)	Peak Load (1 in10) (MW)	2020 LCR as % of Peak Load	Total NQC Local Area Resources (MW)	2020 LCR as % of Total NQC
Humboldt	130	153	85%	197	66%
North Coast/North Bay	742	1492	50%	833	89%
Sierra	1764	1862	95%	2160	82%**
Stockton	629	1275	49%	653	96%**
Greater Bay	4550	10488	43%	7067	64%
Greater Fresno	1694	3278	52%	3177	53%**
Kern	465	1169	40%	465	100%**
Big Creek/Ventura	2410	4956	49%	5099	47%
LA Basin	7364	19261	38%	10439	71%
San Diego/Imperial Valley	3895	4613	84%	4334	90%
Total	23643	48547	49%	34424	69%

Table 3.1-2 2019 Local Capacity Needs vs. Peak Load and Local Area Resources

	2019 Total LCR (MW)	Peak Load (1 in10) (MW)	2019 LCR as % of Peak Load	Total Dependable Local Area Resources (MW)	2019 LCR as % of Total Area Resources
Humboldt	165	187	88%	202	82%
North Coast/North Bay	689	1465	47%	890	77%
Sierra	2247	1758	128%	2150	105%**
Stockton	777	1174	66%	633	123%**
Greater Bay	4461	10230	44%	7054	63%
Greater Fresno	1671	3070	54%	3438	49%**
Kern	478	1088	44%	475	101%**
LA Basin	8116	19266	42%	10225	79%
Big Creek/Ventura	2614	5162	51%	5073	52%
San Diego/Imperial Valley	4026	4412	91%	4358	92%
Total	25244	47812*	53%*	34498	73%

* Value shown only illustrative, since each local area peaks at a different time.

** Resource deficient LCA (or with sub-area that are deficient) – deficiency included in LCR. Resource deficient area implies that in order to comply with the criteria, at summer peak, load must be shed immediately after the first contingency.

Table 3.1-1 and Table 3.1-2 shows how much of the Local Capacity Area load is dependent on local resources and how many local resources must be available in order to serve the load in those Local Capacity Areas in a manner consistent with the Reliability Criteria. These tables also indicate where new transmission projects, new resource additions or demand side management programs would be most useful in order to reduce the dependency on existing, generally older and less efficient local area resources.

The term “Qualifying Capacity” used in this report is the “Net Qualifying Capacity” (“NQC”) posted on the CAISO web site at:

<http://www.caiso.com/planning/Pages/ReliabilityRequirements/Default.aspx>

The NQC list includes the area (if applicable) where each resource is located for units already operational. Neither the NQC list nor this report incorporates Demand Side Management programs and their related NQC. Units scheduled to become operational before June 1 of 2020 have been included in this 2020 LCT Study Report and added to the total NQC values for those respective areas (see detail write-up for each area).

Regarding the main tables up front (page 2), the first column, “Qualifying Capacity,” reflects two sets of resources. The first set is comprised of resources that would normally be expected to be on-line such as Municipal and Regulatory Must-take resources (state, federal, QFs, wind and nuclear units). The second set is “market” resources. The second column, “YEAR LCR Requirement Based on Category B” identifies the local capacity requirements, and deficiencies that must be addressed, in order to achieve a service reliability level based on Performance Criteria- Category B. The third column, “YEAR LCR Requirement Based on Category C with Operating Procedure”, sets forth the local capacity requirements, and deficiencies that must be addressed, necessary to attain a service reliability level based on Performance Criteria-Category C with operational solutions.

3.2 Summary of Zonal Needs

Based on the existing import allocation methodology, the only major 500 kV constraint not accounted for is path 26 (Midway-Vincent). The current method allocates capacity on path 26 similar to the way imports are allocated to LSEs. Table 3.2-1 shows the total resources needed (based on the latest CEC load forecast) in each the two relevant zones, SP26 and NP26.

Table 3.2-1 Total Zonal Resource Need

Zone	Load Forecast (MW)	15% reserves (MW)	(-) Allocated imports (MW)	(-) Allocated Path 26 Flow (MW)	Total Zonal Resource Need (MW)
SP26	26995	4049	-6950	-3750	20344
NP26=NP15+ZP26	20082	3012	-3391	-3000	16703

Where:

Load Forecast is the most recent 1 in 2 CEC forecast for year 2020 - California Energy Demand Updated Forecast, 2018 - 2030, Mid Demand Baseline, Mid AAEE Savings dated February 5, 2019.

Reserve Margin is 15% the minimum CPUC approved planning reserve margin.

Allocated Imports are the actual 2019 Available Import Capability for loads in the CAISO control area numbers that are not expected to change much by 2020 because there are no additional import transmission additions to the grid.

Allocated Path 26 flow The CAISO determines the amount of Path 26 transfer capacity available for RA counting purposes after accounting for (1) Existing Transmission Contracts (ETCs) that serve load outside the CAISO Balancing Area⁸ and (2) loop flow⁹ from the maximum path 26 rating of 4000 MW (North-to-South) and 3000 MW (South-to-North).

Both NP 26 and SP 26 load forecast, import allocation and zonal results refer to the CAISO Balancing Area only. This is done in order to be consistent with the import allocation methodology.

All resources that are counted as part of the Local Area Capacity Requirements fully count toward the Zonal Need. The local areas of San Diego, LA Basin and Big Creek/Ventura are all situated in SP26 and the remaining local areas are in NP26.

3.2.1.1 **Changes compared to last year's results:**

The load forecast went up in Southern California by about 700 MW and down in Northern California by about 900 MW.

The Import Allocations went down in Southern California by about 650 MW and down in Northern California by about 200 MW.

The Path 26 transfer capability has not changed and is not envisioned to change in the near future. As such, the LSEs should assume that their load/share ratio allocation for path 26 will stay at the same levels as 2018. If there are any changes, they will be heavily influenced by the pre-existing "grandfathered contracts" and when they expire most of the LSEs will likely see their load share ratio going up, while the owners of these grandfathered contracts may see their share decreased to the load-share ratio.

⁸ The transfer capability on Path 26 must be de-rated to accommodate ETCs on Path 26 that are used to serve load outside of the CAISO Balancing Area. These particular ETCs represent physical transmission capacity that cannot be allocated to LSEs within the CAISO Balancing Area.

⁹ "Loop flow" is a phenomenon common to large electric power systems like the Western Electricity Coordinating Council. Power is scheduled to flow point-to-point on a Day-ahead and Hour-ahead basis through the CAISO. However, electric grid physics prevails and the actual power flow in real-time will differ from the pre-arranged scheduled flows. Loop flow is real, physical energy and it uses part of the available transfer capability on a path. If not accommodated, loop flow will cause overloading of lines, which can jeopardize the security and reliability of the grid.

3.3 Summary of Results by Local Area

Each Local Capacity Area's overall requirement is determined by also achieving each sub-area requirement. Because these areas are a part of the interconnected electric system, the total for each Local Capacity Area is not simply a summation of the sub-area needs. For example, some sub-areas may overlap and therefore the same units may count for meeting the needs in both sub-areas.

3.3.1 Humboldt Area

3.3.1.1 Area Definition

The transmission tie lines into the area include:

- Bridgeville-Cottonwood 115 kV line #1
- Humboldt-Trinity 115 kV line #1
- Laytonville-Garberville 60 kV line #1
- Trinity-Maple Creek 60 kV line #1

The substations that delineate the Humboldt Area are:

- Bridgeville is in, Low Gap, Wildwood and Cottonwood are out
- Humboldt is in, Trinity is out
- Kekawaka and Garberville are in, Laytonville is out
- Maple Creek is in, Trinity and Ridge Cabin are out

3.3.1.1.1 Humboldt LCR Area Diagram

Figure 3.3-1 Humboldt LCR Area

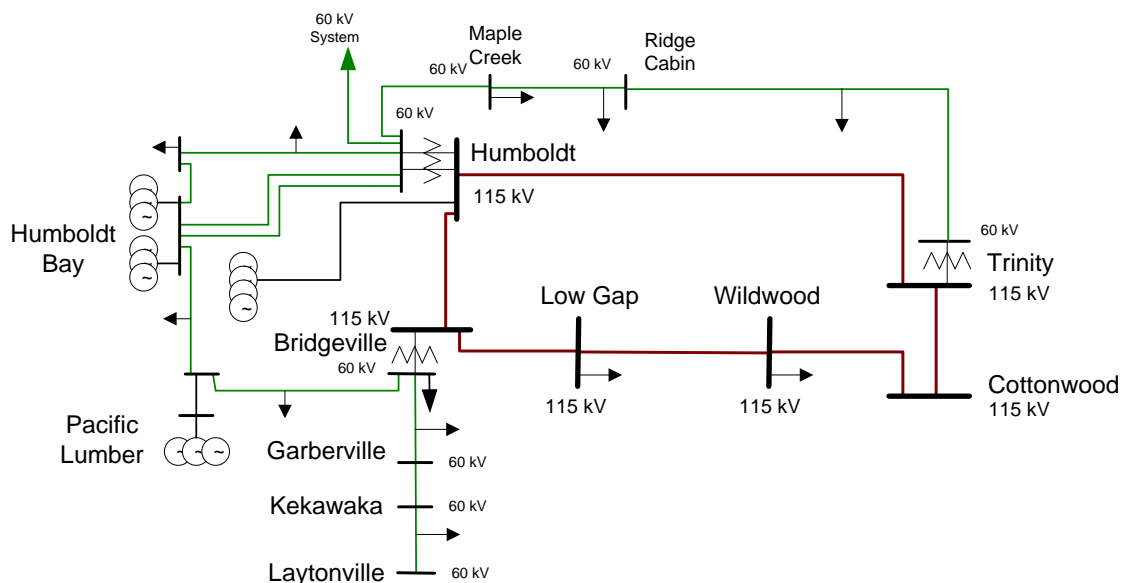

3.3.1.1.2 Humboldt LCR Area Load and Resources

Table 3.3-1 provides the forecasted load and resources. The list of generators within the LCR area are provided in Attachment A.

In year 2020 the estimated time of local area peak is 18:40 PM.

At the local area peak time the estimated, behind the meter, solar output is 0.00%.

This area does not contain models of solar resources capable of providing resource adequacy.

If required, all non-solar technology type resources are dispatched at NQC.

Table 3.3-1 Humboldt LCR Area 2020 Forecast Load and Resources

Load (MW)		Generation (MW)	NQC	At Peak
Gross Load	151	Market and Net Seller	197	197
AAEE	-8	MUNI	0	0
Behind the meter DG	0	QF	0	0
Net Load	143	LTPP Preferred Resources	0	0
Transmission Losses	10	Existing 20-minute Demand Response	0	0
Pumps	0	Mothballed	0	0
Load + Losses + Pumps	153	Total	197	197

3.3.1.1.3 Humboldt LCR Area Hourly Profiles

Figure 3.3-2 illustrates the forecast 2020 profile for the summer peak, winter peak and spring off-peak days for the Humboldt LCR area with the Category C (Multiple Contingency) transmission capability without resources. Figure 3.3-3 illustrates the forecast 2020 hourly profile for Humboldt LCR area with the Category C (Multiple Contingency) transmission capability without resources.

Figure 3.3-2 Humboldt 2020 Peak Day Forecast Profiles

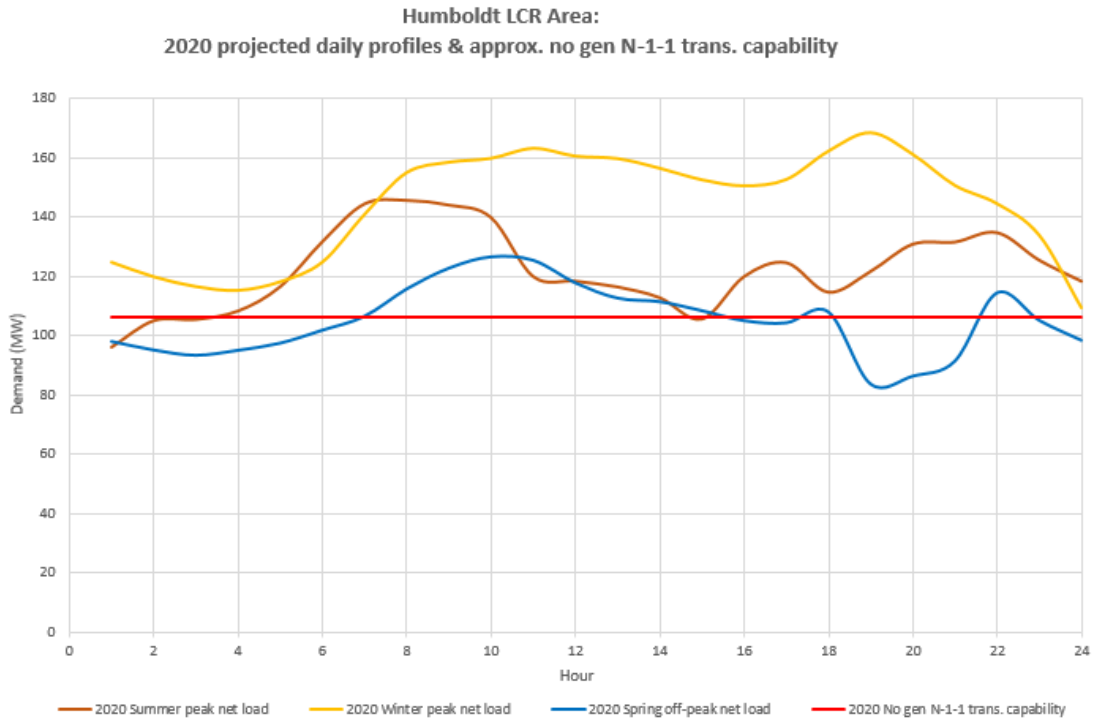
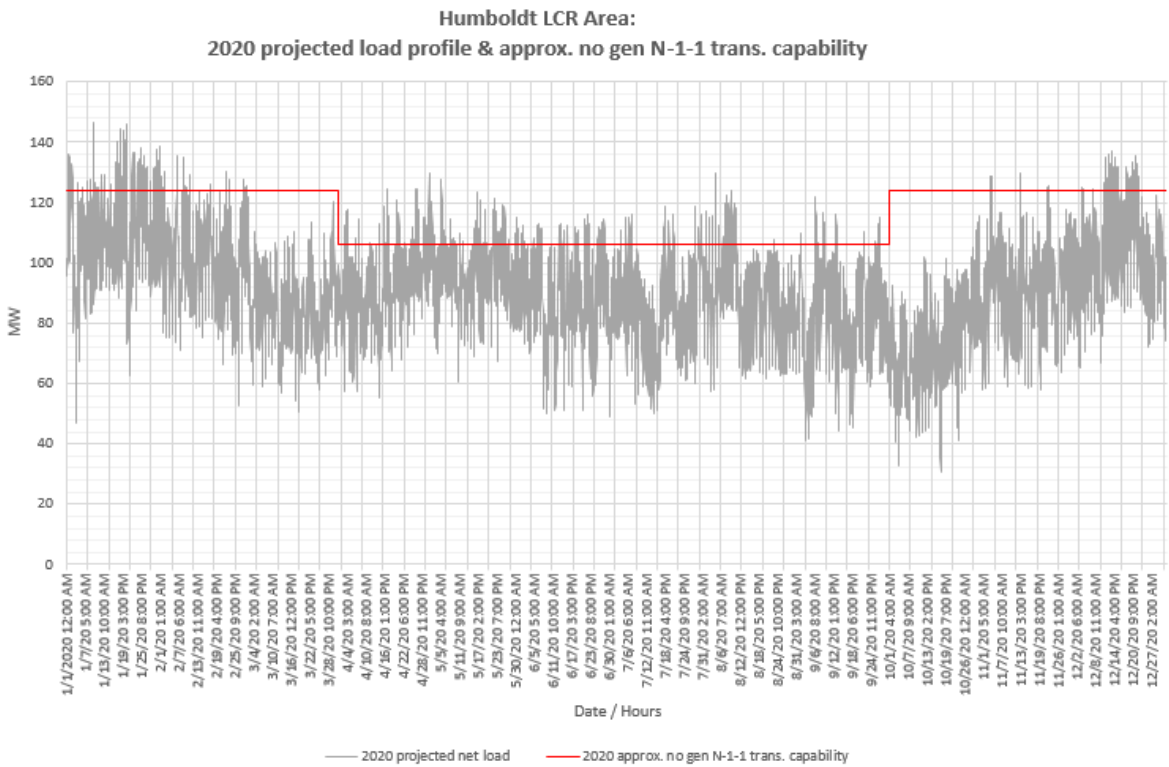

Figure 3.3-3 Humboldt 2020 Forecast Hourly Profile



3.3.1.1.4 Approved transmission projects included in base cases

None

3.3.1.2 Humboldt Overall LCR Requirement

Table 3.3-2 identifies the area LCR requirements. The LCR requirement for Category B (Single Contingency) is 116 MW and for Category C (Multiple Contingency) is 165 MW.

Table 3.3-2 Humboldt LCR Area Requirements

Year	Limit	Category	Limiting Facility	Contingency	LCR (MW) (Deficiency)
2020	First Limit	B ¹⁰	Humboldt-Trinity 115 kV	Cottonwood-Bridgeville 11 5kV line with one of the Humboldt Bay units	83
2020	First Limit	C ¹¹	Humboldt-Trinity 115 kV	Cottonwood-Bridgeville 115 kV & Humboldt - Humboldt Bay 115 kV	130

3.3.1.2.1 Effectiveness factors

For most helpful procurement information please read procedure 2210Z Effectiveness Factors under 7110 (T-138Z) posted at: <http://www.caiso.com/Documents/2210Z.pdf>

3.3.1.2.2 Changes compared to last year’s results

Compared with 2019 the load forecast decreased by 34 MW and the total LCR has decreased by 35 MW.

3.3.2 North Coast / North Bay Area

3.3.2.1 Area Definition

The transmission tie facilities coming into the North Coast/North Bay area are:

¹⁰ LCR requirement for a single contingency means that there wouldn’t be any criteria violations following the loss of a single element, however the operators will not have any means (other than load drop) in order to bring the system within a safe operating zone and get prepared for the next contingency as required by NERC transmission operations standards.

¹¹ LCR requirement for multiple contingencies means that not only there wouldn’t be any criteria violations following the loss of a single element, but also the operators will have enough generation (other operating procedures) in order to bring the system within a safe operating zone and get prepared for the next contingency as required by NERC transmission operations standards.

- Cortina-Mendocino 115 kV Line
- Cortina-Eagle Rock 115 kV Line
- Willits-Garberville 60 kV line #1
- Vaca Dixon-Lakeville 230 kV line #1
- Tulucay-Vaca Dixon 230 kV line #1
- Lakeville-Sobrante 230 kV line #1
- Ignacio-Sobrante 230 kV line #1

The substations that delineate the North Coast/North Bay area are:

- Cortina is out, Mendocino and Indian Valley are in
- Cortina is out, Eagle Rock, Highlands and Homestake are in
- Willits and Lytonville are in, Kekawaka and Garberville are out
- Vaca Dixon is out, Lakeville is in
- Tulucay is in, Vaca Dixon is out
- Lakeville is in, Sobrante is out
- Ignacio is in, Sobrante and Crocket are out

3.3.2.1.1 North Coast and North Bay LCR Area Diagram

Figure 3.3-4 North Coast and North Bay LCR Area

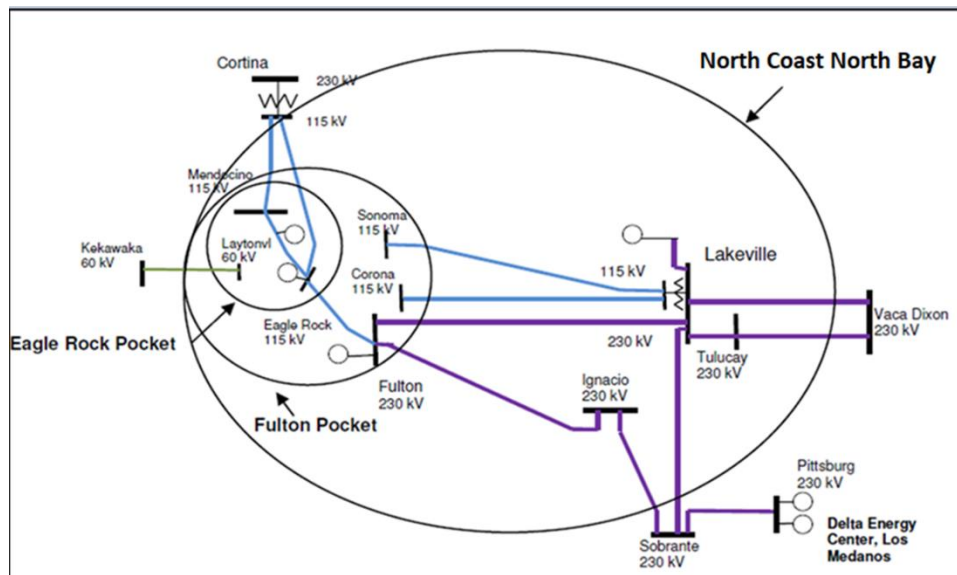

3.3.2.1.2 North Coast and North Bay LCR Area Load and Resources

Table 3.3-3 provides the forecasted load and resources. The list of generators within the LCR area are provided in Attachment A.

In year 2020 the estimated time of local area peak is 17:50 PM.

At the local area peak time the estimated, behind the meter, solar output is 14.46%.

This area does not contain models of solar resources capable of providing resource adequacy.

If required, all non-solar technology type resources are dispatched at NQC.

Table 3.3-3 North Coast and North Bay LCR Area 2020 Forecast Load and Resources

Load (MW)		Generation (MW)	NQC	At Peak
Gross Load	1525	Market and Net Seller	715	715
AAEE	-16	MUNI	113	113
Behind the meter DG	-58	QF	4	4
Net Load	1451	Solar	1	0
Transmission Losses	41	Existing 20-minute Demand Response	0	0
Pumps	0	Mothballed	0	0
Load + Losses + Pumps	1492	Total	833	832

3.3.2.1.3 North Coast and North Bay LCR Area Hourly Profiles

Figure 3.3-5 illustrates the forecast 2020 profile for the summer peak, winter peak and spring off-peak days for the North Coast and North Coast LCR area with the Category C (Multiple Contingency) transmission capability without resources. Figure 3.3-6 illustrates the forecast 2020 hourly profile for North Coast and North Bay LCR area with the Category C (Multiple Contingency) transmission capability without resources.

Figure 3.3-5 North Coast and North Bay 2020 Peak Day Forecast Profiles

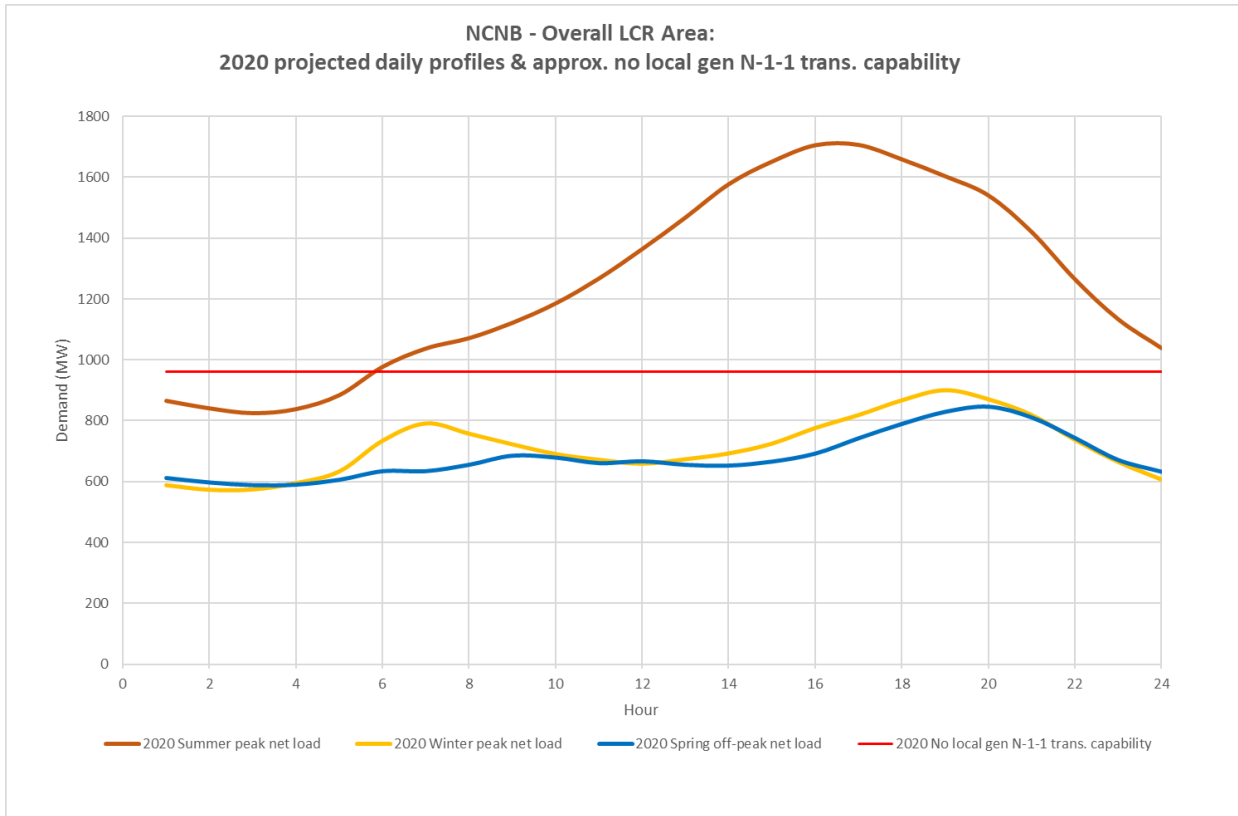
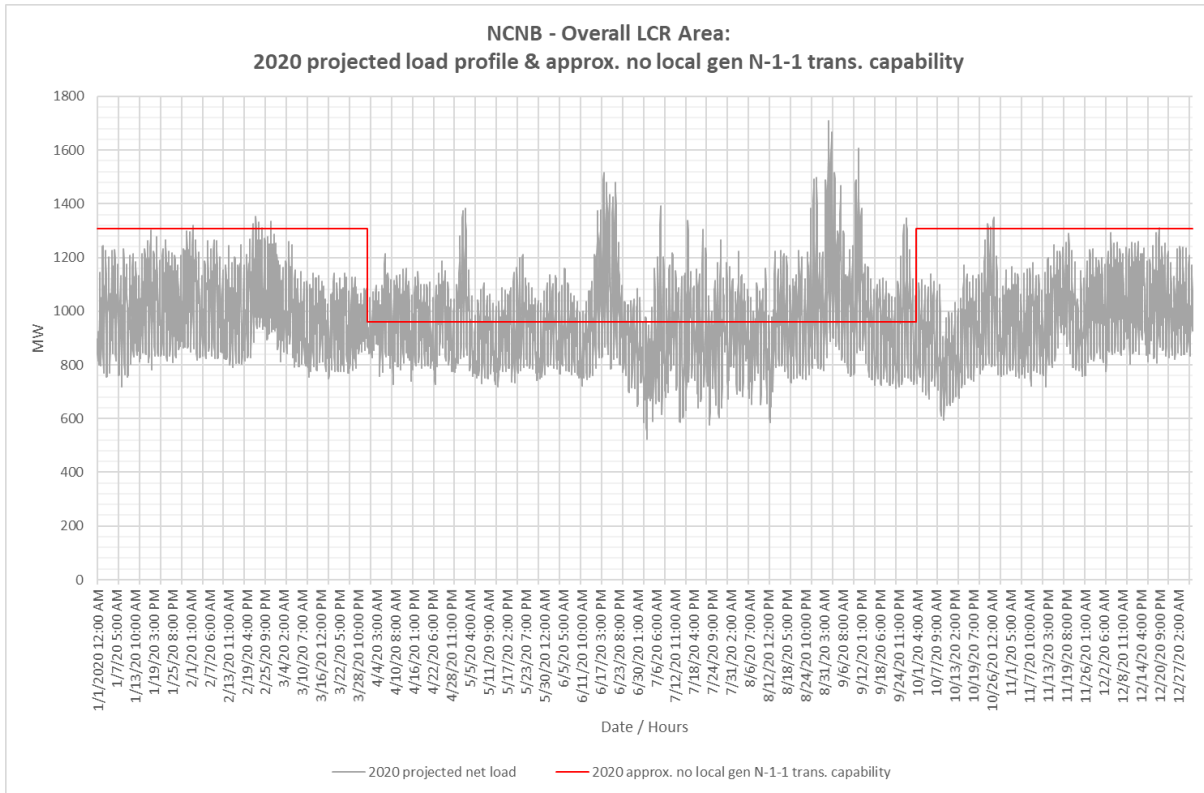

Figure 3.3-6 North Coast and North Bay 2020 Forecast Hourly Profile



3.3.2.1.4 Approved transmission projects modeled in base cases

- Vaca Dixon-Lakeville 230 kV Corridor Series Compensation
- Fulton-Fitch Mountain 60 kV Line Reconductor
- Clear Lake 60 kV System Reinforcement
- Ignacio-Alta 60 kV Line Conversion
- Lakeville 60 kV Area Reinforcement

3.3.2.2 Eagle Rock LCR Sub-area

Eagle Rock is a Sub-area of the North Coast and North Bay LCR Area.

3.3.2.2.1 Eagle Rock LCR Sub-area Diagram

Figure 3.3-7 Eagle Rock LCR Sub-area

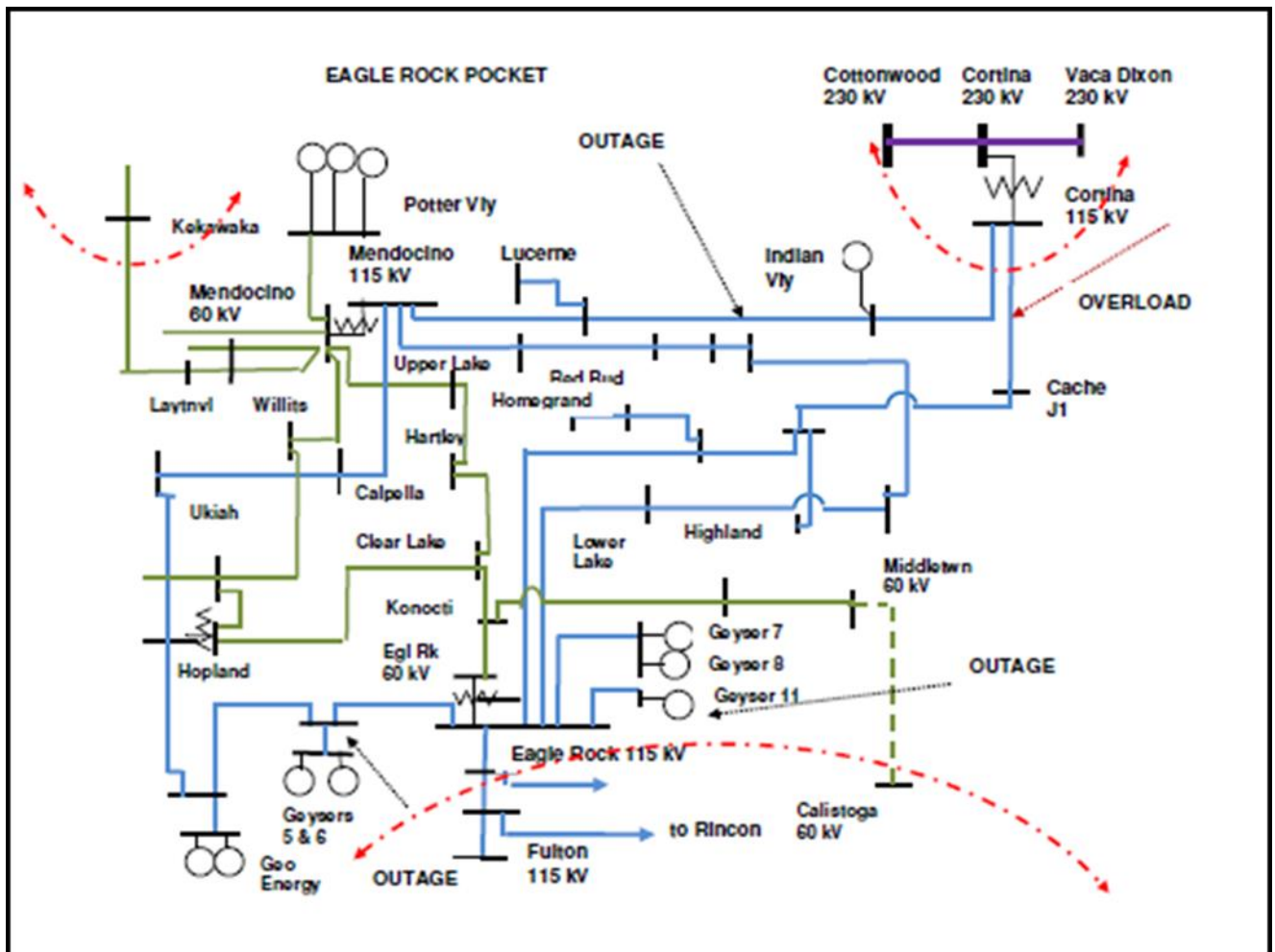

3.3.2.2.2 Eagle Rock LCR sub-area Load and Resources

Table 3.3-4 provides the forecasted load and resources. The list of generators within the LCR sub-area are provided in Attachment A.

Table 3.3-4 Eagle Rock LCR Sub-area 2020 Forecast Load and Resources

Load (MW)		Generation (MW)	NQC	At Peak
Gross Load	257	Market and Net Seller	248	248
AAEE	-3	MUNI	2	2
Behind the meter DG	-7	QF	0	0
Net Load	247	Solar	1	0
Transmission Losses	12	Existing 20-minute Demand Response	0	0
Pumps	0	Mothballed	0	0
Load + Losses + Pumps	259	Total	251	250

3.3.2.2.3 Eagle Rock LCR Sub-area Hourly Profiles

Figure 3.3-5 illustrates the forecast 2020 profile for the summer peak, winter peak and spring off-peak days for the Eagle Rock LCR Sub-area with the Category C (Multiple Contingency) transmission capability without resources. Figure 3.3-6 illustrates the forecast 2020 hourly profile for Eagle Rock LCR Sub-area with the Category C (Multiple Contingency) transmission capability without resources.

Figure 3.3-8 Eagle Rock LCR Sub-area 2020 Peak Day Forecast Profiles

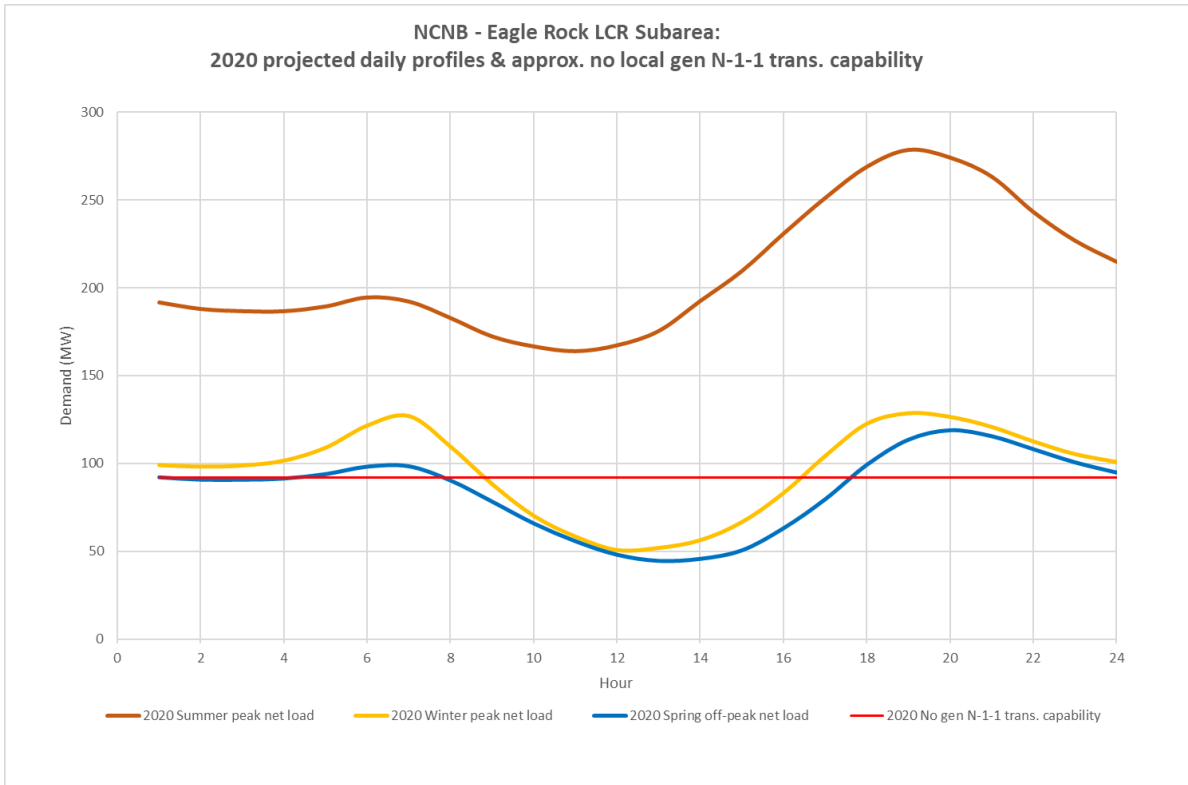
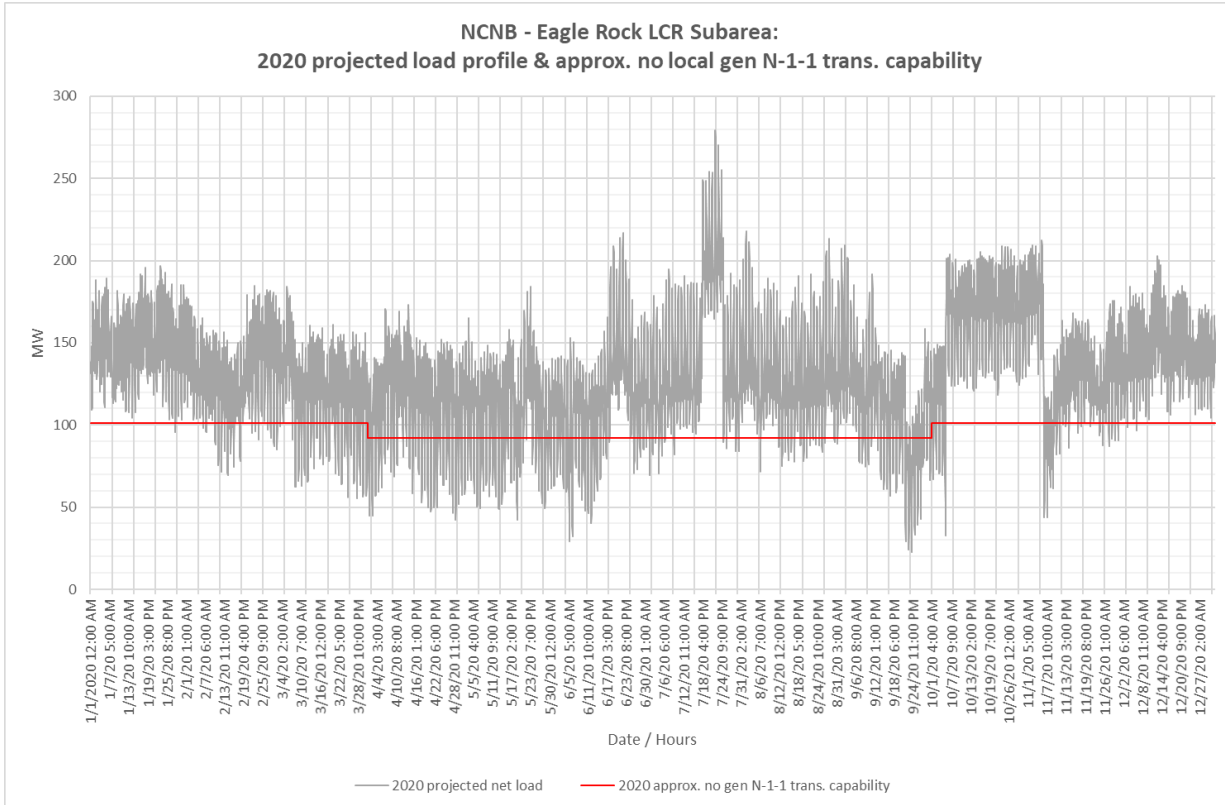

Figure 3.3-9 Eagle Rock LCR Sub-area 2020 Forecast Hourly Profiles



3.3.2.2.4 Eagle Rock LCR Sub-area Requirement

Table 3.3-5 identifies the sub-area LCR requirements. The LCR requirement for Category B (Single Contingency) is 210 MW and for Category C (Multiple Contingency) is 227 MW.

Table 3.3-5 Eagle Rock LCR Sub-area Requirements

Year	Limit	Category	Limiting Facility	Contingency	LCR (MW) (Deficiency)
2020	First Limit	B	Eagle Rock-Cortina 115 kV line	Cortina-Mendocino 115 kV with Geysers #11 unit out	210
2020	First Limit	C	Eagle Rock-Cortina 115 kV line	Cortina-Mendocino 115 kV & Geysers #3-Geysers #5 115 kV	227

3.3.2.2.5 Effectiveness factors

Effective factors for generators in the Eagle Rock LCR Sub-area are in Attachment B table titled [Eagle Rock](#).

For most helpful procurement information please read procedure 2210Z Effectiveness Factors under 7110 (T-138Z) posted at: <http://www.caiso.com/Documents/2210Z.pdf>

3.3.2.3 Fulton Sub-area

Fulton is a Sub-area of the North Coast and North Bay LCR Area.

3.3.2.3.1 Fulton LCR Sub-area Diagram

Figure 3.3-10 Fulton LCR Sub-area

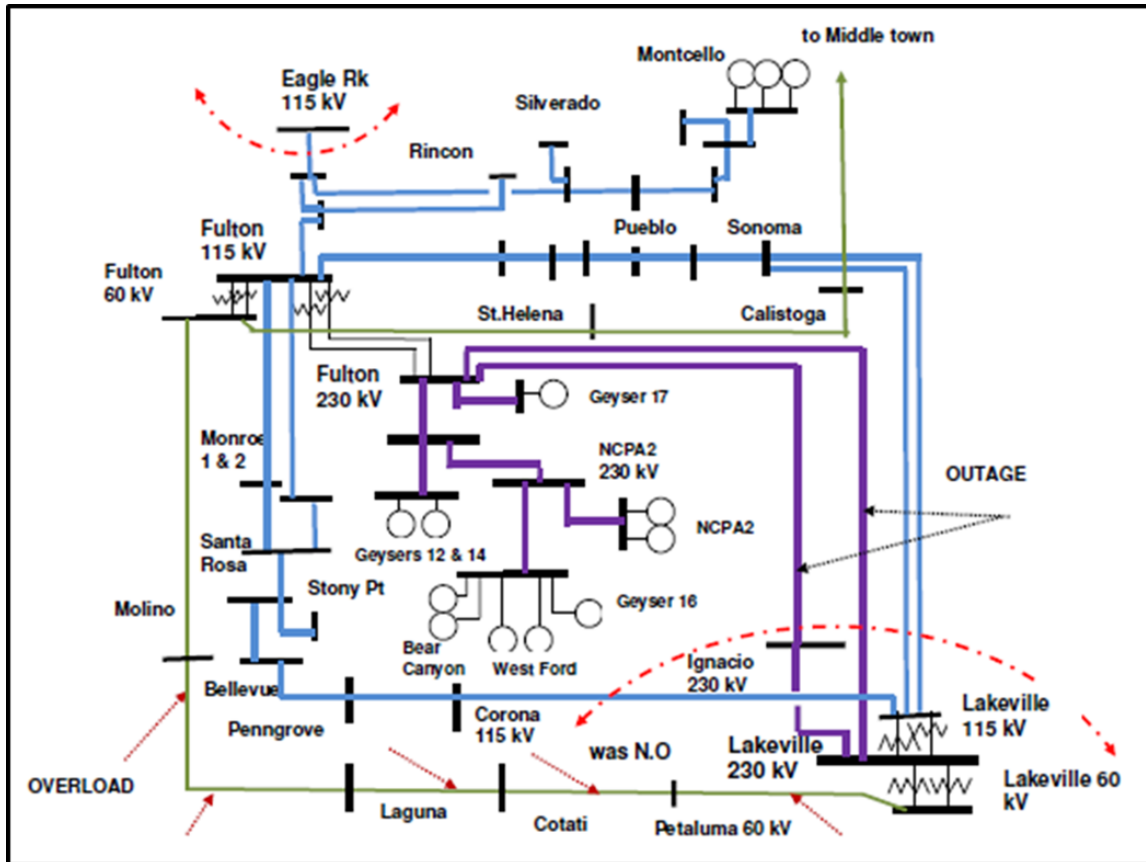

3.3.2.3.2 Fulton LCR Sub-area Load and Resources

Table 3.3-6 provides the forecasted load and resources. The list of generators within the LCR sub-area are provided in Attachment A.

Table 3.3-6 Fulton LCR Area 2020 Forecast Load and Resources

Load (MW)		Generation (MW)	NQC	At Peak
Gross Load	895	Market	460	460
AAEE	-10	MUNI	55	55
Behind the meter DG	-33	QF	4	4
Net Load	852	Solar	1	0
Transmission Losses	23	Existing 20-minute Demand Response	0	0
Pumps	0	Mothballed	0	0
Load + Losses + Pumps	875	Total	520	519

3.3.2.3.3 Fulton LCR Sub-area Hourly Profiles

Figure 3.3-11 illustrates the forecast 2020 profile for the summer peak, winter peak and spring off-peak days for the Fulton LCR Sub-area with the Category C (Multiple Contingency) transmission capability without resources. Figure 3.3-12 illustrates the forecast 2020 hourly profile for Fulton LCR Sub-area with the Category C (Multiple Contingency) transmission capability without resources.

Figure 3.3-11 Fulton LCR Sub-area 2020 Peak Day Forecast Profiles

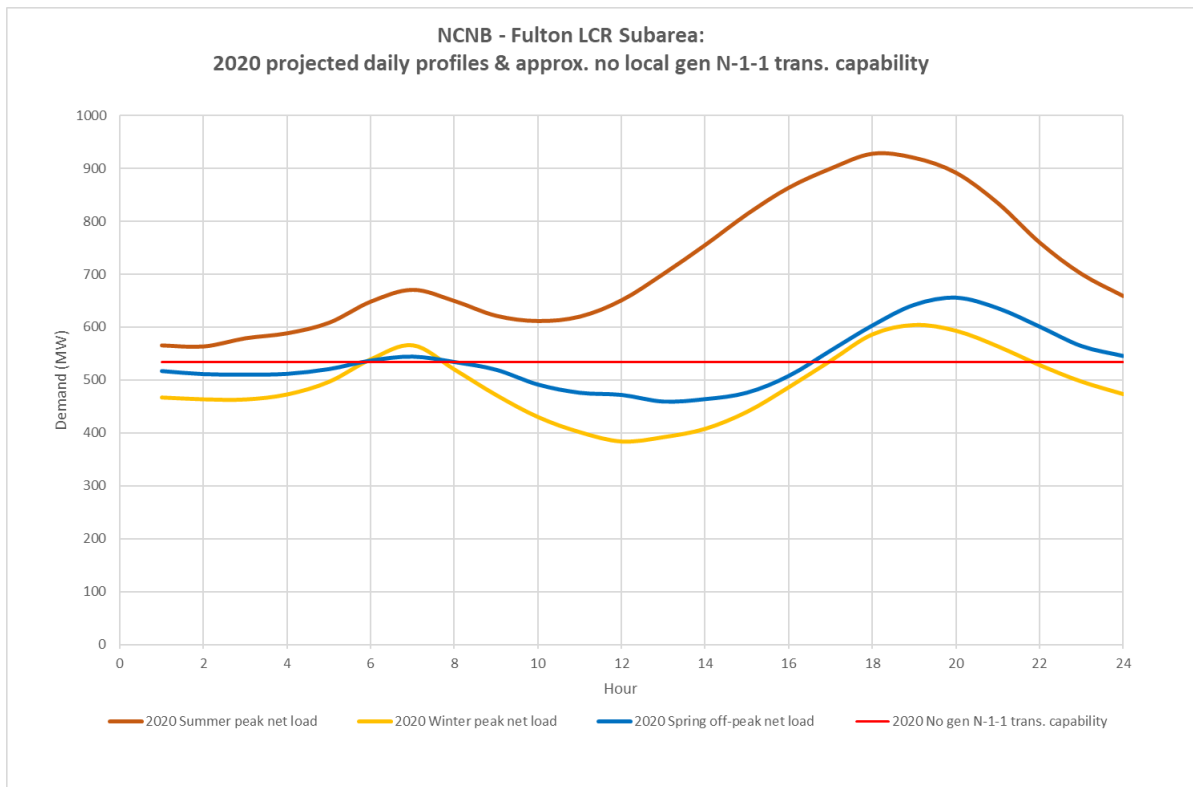
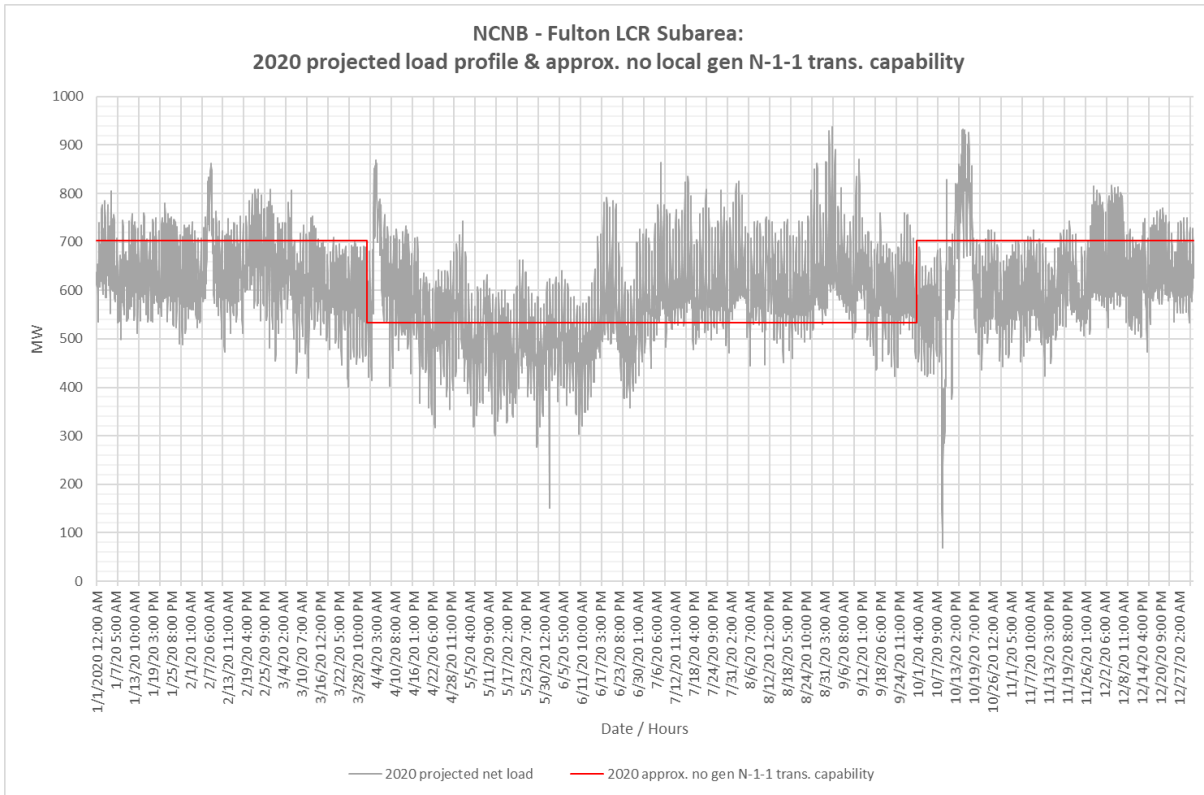

Figure 3.3-12 Fulton LCR Sub-area 2020 Forecast Hourly Profiles



3.3.2.3.4 Fulton LCR Sub-area Requirement

Table 3.3-7 identifies the sub-area LCR requirements. The LCR requirement for Category B (Single Contingency) is non-binding and for Category C (Multiple Contingency) is 456 MW.

Table 3.3-7 Fulton LCR Sub-area Requirements

Year	Limit	Category	Limiting Facility	Contingency	LCR (MW) (Deficiency)
2020	First Limit	B	Non-binding		
2020	First Limit	C	Lakeville #2 (Lakeville-Petaluma-Cotati) 60 kV line	Fulton-Lakeville #1 230 kV & Fulton-Ignacio #1 230 kV	456

3.3.2.3.5 Effectiveness factors

Effective factors for generators in the Fulton LCR Sub-area are in Attachment B table titled [Fulton](#).

For most helpful procurement information please read procedure 2210Z Effectiveness Factors under 7110 (T-138Z) posted at: <http://www.caiso.com/Documents/2210Z.pdf>

3.3.2.4 North Coast and North Bay Overall

Lakeville Sub-area represents the North Coast and North Bay LCR overall requirement.

3.3.2.4.1 North Coast and North Bay Overall Requirement

Table 3.3-8 identifies the sub-area LCR requirements. The LCR requirement for Category B (Single Contingency) and for Category C (Multiple Contingency) are 742 MW.

Table 3.3-8 North Coast and North Bay LCR area Requirements

Year	Limit	Category	Limiting Facility	Contingency	LCR (MW) (Deficiency)
2020	First Limit	B/C	Vaca Dixon-Lakeville 230 kV	Vaca Dixon-Tulucay 230 kV with DEC power plant out of service	742

3.3.2.4.2 Effectiveness factors

Effective factors for generators in the North Coast and North Bay LCR area are in Attachment B table titled [North Coast and North Bay](#).

For most helpful procurement information please read procedure 2210Z Effectiveness Factors under 7110 (T-138Z) posted at: <http://www.caiso.com/Documents/2210Z.pdf>

3.3.2.4.3 Changes compared to last year’s results

Compared to 2019 load forecast went up by 27 MW and total LCR need went up by 53 MW mainly due to load increase.

3.3.3 Sierra Area

3.3.3.1 Area Definition

The transmission tie lines into the Sierra Area are:

- Table Mountain-Rio Oso 230 kV line
- Table Mountain-Palermo 230 kV line
- Table Mt-Pease 60 kV line
- Caribou-Palermo 115 kV line
- Drum-Summit 115 kV line #1

- Drum-Summit 115 kV line #2
- Spaulding-Summit 60 kV line
- Brighton-Bellota 230 kV line
- Rio Oso-Lockeford 230 kV line
- Gold Hill-Eight Mile Road 230 kV line
- Lodi-Eight Mile Road 230 kV line
- Gold Hill-Lake 230 kV line

The substations that delineate the Sierra Area are:

- Table Mountain is out Rio Oso is in
- Table Mountain is out Palermo is in
- Table Mt is out Pease is in
- Caribou is out Palermo is in
- Drum is in Summit is out
- Drum is in Summit is out
- Spaulding is in Summit is out
- Brighton is in Bellota is out
- Rio Oso is in Lockeford is out
- Gold Hill is in Eight Mile is out
- Lodi is in Eight Mile is out
- Gold Hill is in Lake is out

3.3.3.1.1 Sierra LCR Area Diagram

Figure 3.3-13 Sierra LCR Area

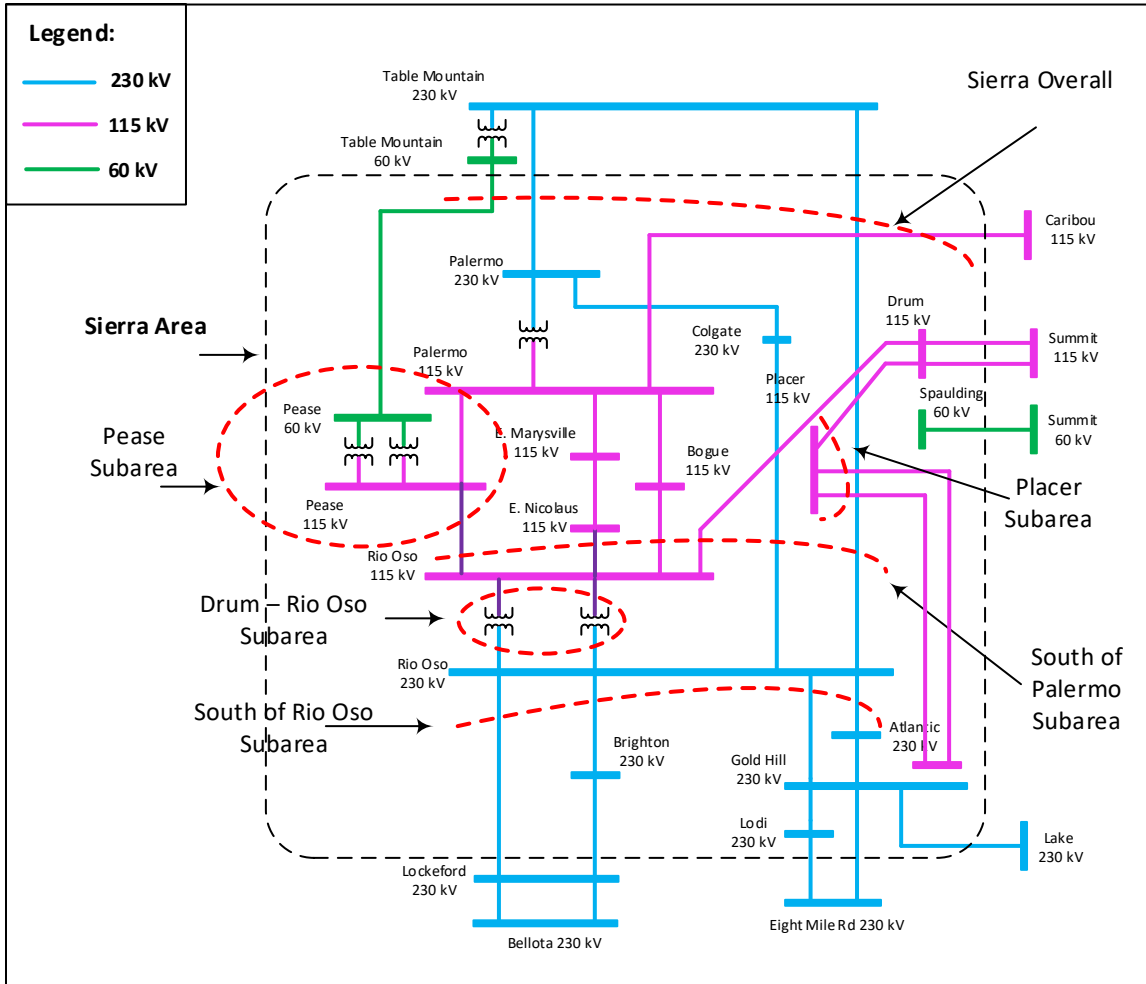

3.3.3.1.2 Sierra LCR Area Load and Resources

Table 3.3-9 provides the forecasted load and resources. The list of generators within the LCR area are provided in Attachment A.

In year 2020 the estimated time of local area peak is 19:10 PM.

At the local area peak time the estimated, behind the meter, solar output is 0.00%.

At the local area peak time the estimated, ISO metered, solar output is 2.00%.

If required, all non-solar technology type resources are dispatched at NQC.

Table 3.3-9 Sierra LCR Area 2020 Forecast Load and Resources

Load (MW)		Generation (MW)	NQC	At Peak
Gross Load	1798	Market and Net Seller	986	986
AAEE	-22	MUNI	1129	1129
Behind the meter DG	0	QF	39	39

Net Load	1776	Solar	6	0
Transmission Losses	86	Existing 20-minute Demand Response	0	0
Pumps	0	Mothballed	0	0
Load + Losses + Pumps	1862	Total	2160	2154

3.3.3.1.3 Approved transmission projects modeled:

- Gold Hill-Missouri Flat #1 and #2 115 kV line reconductoring (In Service)
- Pease 115/60 kV transformer addition

3.3.3.2 Placerville Sub-area

Placerville Sub-area has been eliminated due to the Missouri Flat-Gold Hill 115 kV lines reconductoring project being operational.

3.3.3.3 Placer Sub-area

Placer is Sub-area of the Sierra LCR Area.

3.3.3.3.1 Placer LCR Sub-area Diagram

Figure 3.3-14 Placer LCR Sub-area

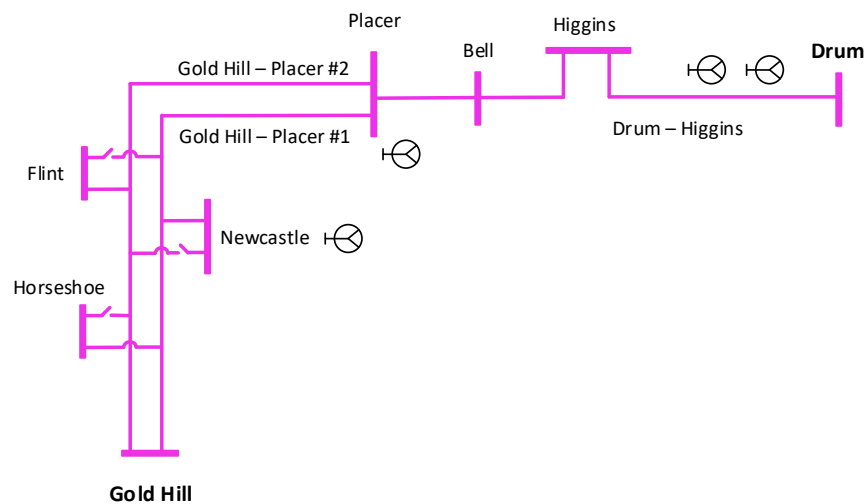

3.3.3.3.2 Placer LCR Sub-area Load and Resources

Table 3.3-10 provides the forecasted load and resources. The list of generators within the LCR sub-area are provided in Attachment A.

Table 3.3-10 Placer LCR Sub-area 2020 Forecast Load and Resources

Load (MW)	Generation (MW)	NQC	At Peak
-----------	-----------------	-----	---------

Gross Load	175	Market and Net Seller	53	53
AAEE	-2	MUNI	42	42
Behind the meter DG	0	QF	0	0
Net Load	173	Solar	0	0
Transmission Losses	5	Existing 20-minute Demand Response	0	0
Pumps	0	Mothballed	0	0
Load + Losses + Pumps	178	Total	95	95

3.3.3.3.3 Placer LCR Sub-area Hourly Profiles

Figure 3.3-15 illustrates the forecast 2020 profile for the summer peak, winter peak and spring off-peak days for the Placer LCR Sub-area with the Category C (Multiple Contingency) transmission capability without resources. Figure 3.3-16 illustrates the forecast 2020 hourly profile for Placer LCR Sub-area with the Category C (Multiple Contingency) transmission capability without resources.

Figure 3.3-15 Placer LCR Sub-area 2020 Peak Day Forecast Profiles

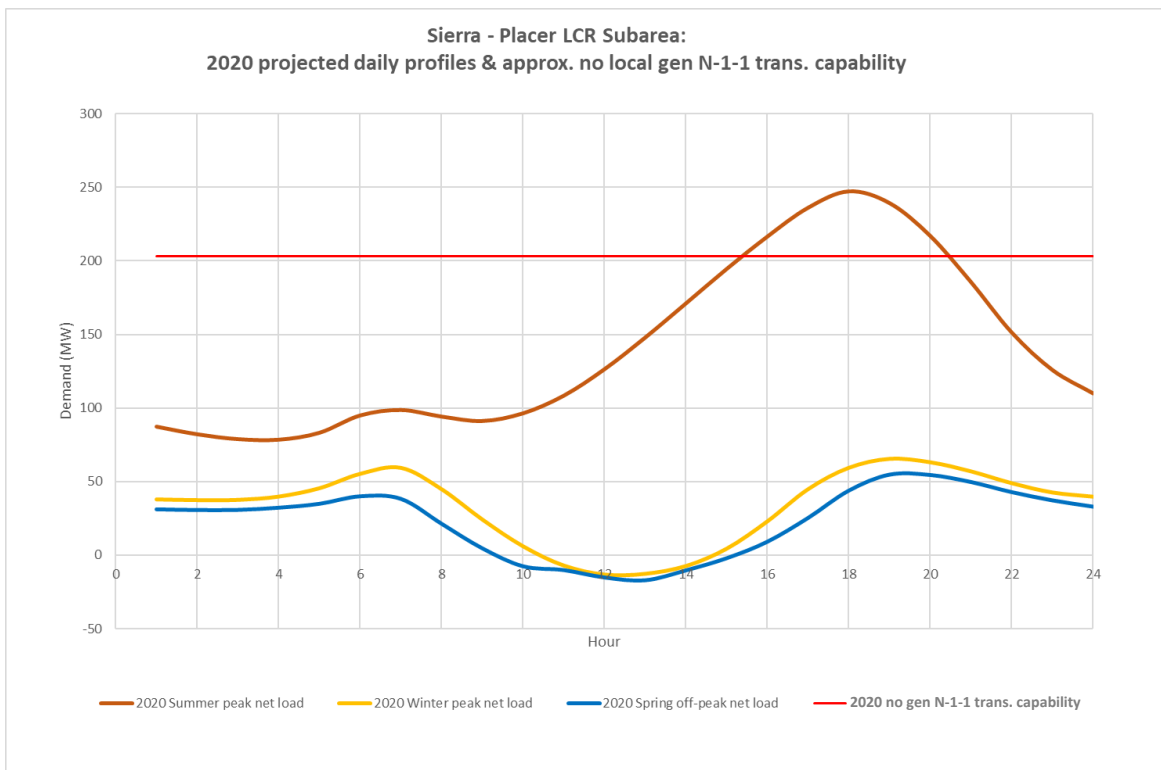
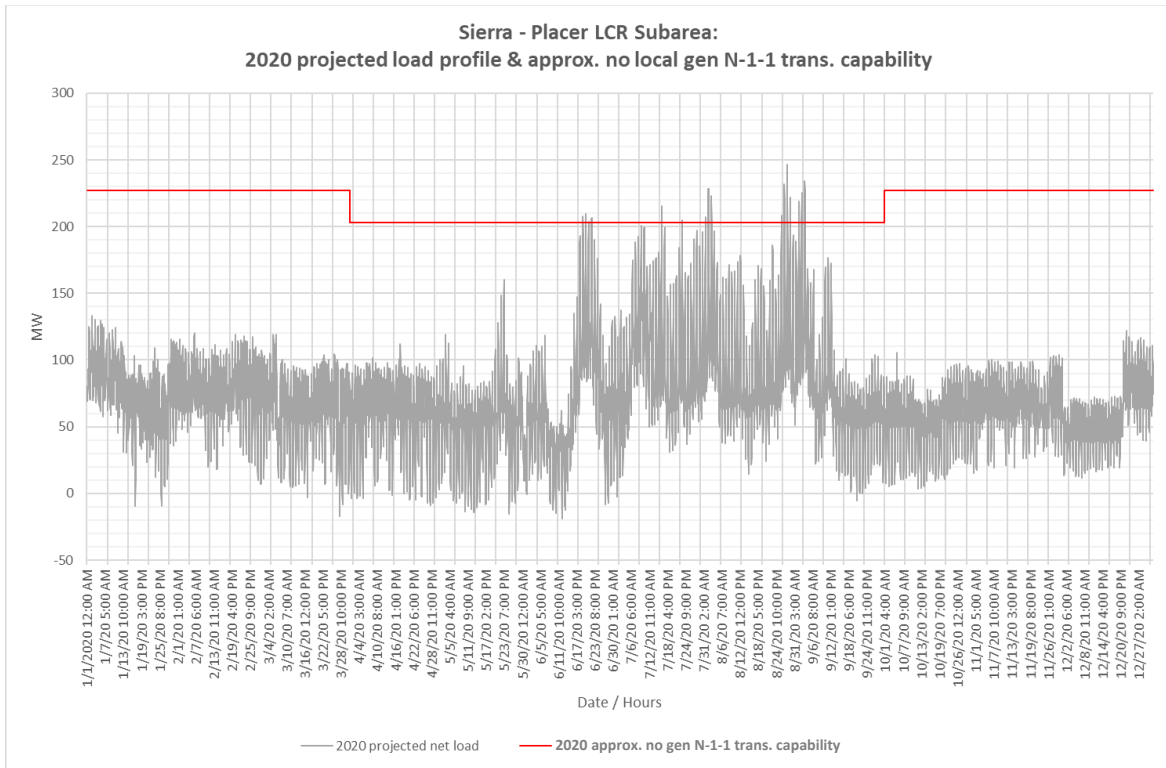

Figure 3.3-16 Placer LCR Sub-area 2020 Forecast Hourly Profiles



3.3.3.3.4 Placer LCR Sub-area Requirement

Table 3.3-11 identifies the sub-area requirements. The Category B (Single Contingency) LCR requirement is 56 MW and the LCR requirement for Category C (Multiple Contingency) is 93 MW.

Table 3.3-11 Placer LCR Sub-area Requirements

Year	Limit	Category	Limiting Facility	Contingency	LCR (MW) (Deficiency)
2020	First Limit	B	Drum-Higgins 115 kV	Gold Hill-Placer 115 kV with Chicago Park out of service	56
2020	First Limit	C	Drum-Higgins 115 kV	Gold Hill-Placer #1 115 kV & Gold Hill-Placer #2 115 kV	93

3.3.3.3.5 Effectiveness factors

All units within the Placer Sub-area have the same effectiveness factor.

For most helpful procurement information please read procedure 2210Z Effectiveness Factors under 7240 posted at: <http://www.caiso.com/Documents/2210Z.pdf>

3.3.3.4 Pease Sub-area

Pease is Sub-area of the Sierra LCR Area.

3.3.3.4.1 Pease LCR Sub-area Diagram

Figure 3.3-17 Pease LCR Sub-area

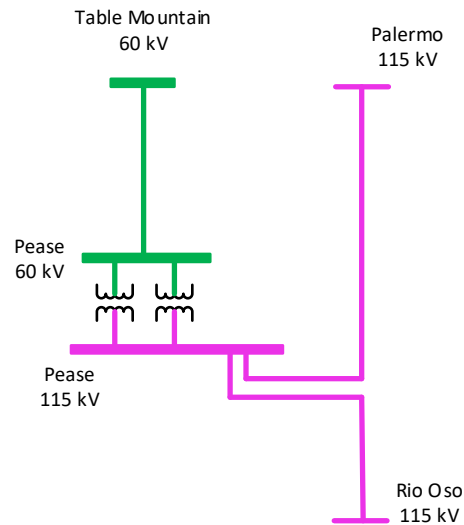

3.3.3.4.2 Pease LCR Sub-area Load and Resources

Table 3.3-12 provides the forecasted load and resources. The list of generators within the LCR sub-area are provided in Attachment A.

Table 3.3-12 Pease LCR Sub-area 2020 Forecast Load and Resources

Load (MW)		Generation (MW)	NQC	At Peak
Gross Load	161	Market and Net Seller	97	97
AAEE	-2	MUNI	0	0
Behind the meter DG	0	QF	38	38
Net Load	159	Solar	1	0
Transmission Losses	2	Existing 20-minute Demand Response	0	0
Pumps	0	Mothballed	0	0
Load + Losses + Pumps	161	Total	136	135

3.3.3.4.3 Pease LCR Sub-area Hourly Profiles

Figure 3.3-18 illustrates the forecast 2020 profile for the summer peak, winter peak and spring off-peak days for the Pease LCR Sub-area with the Category C (Multiple Contingency) transmission capability without resources. Figure 3.3-19 illustrates the forecast 2020 hourly profile

for Pease LCR Sub-area with the Category C (Multiple Contingency) transmission capability without resources.

Figure 3.3-18 Pease LCR Sub-area 2020 Peak Day Forecast Profiles

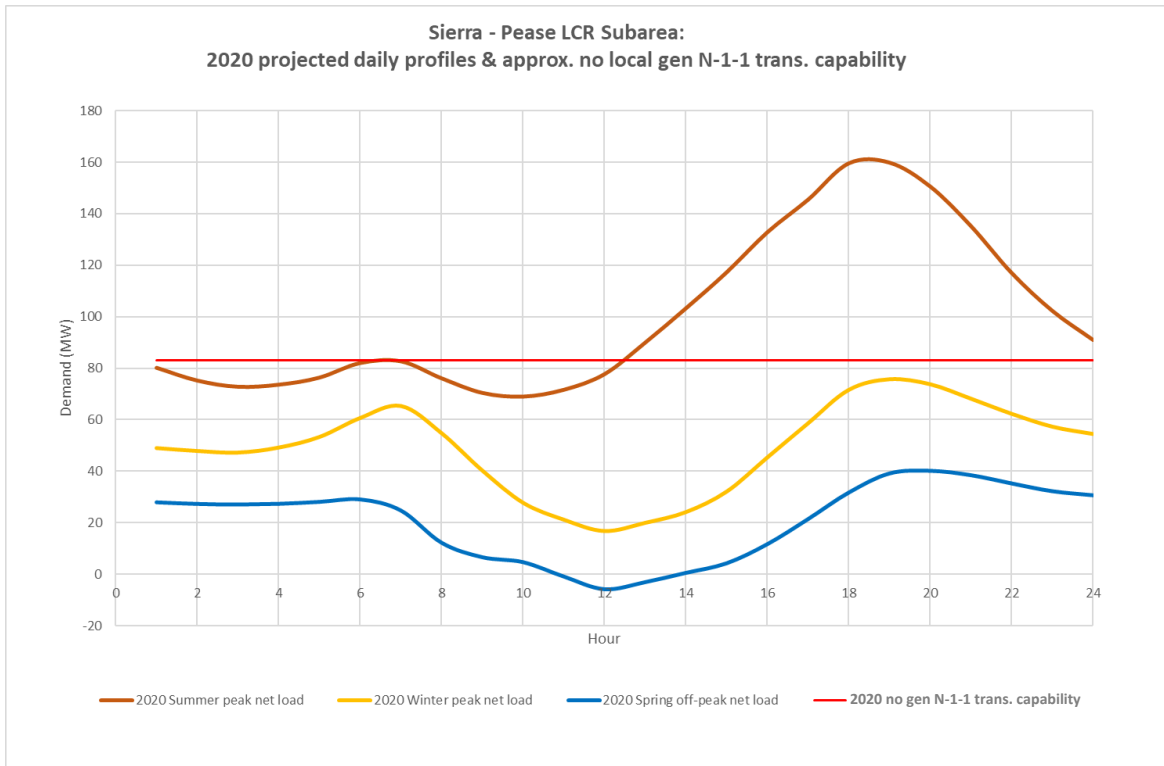
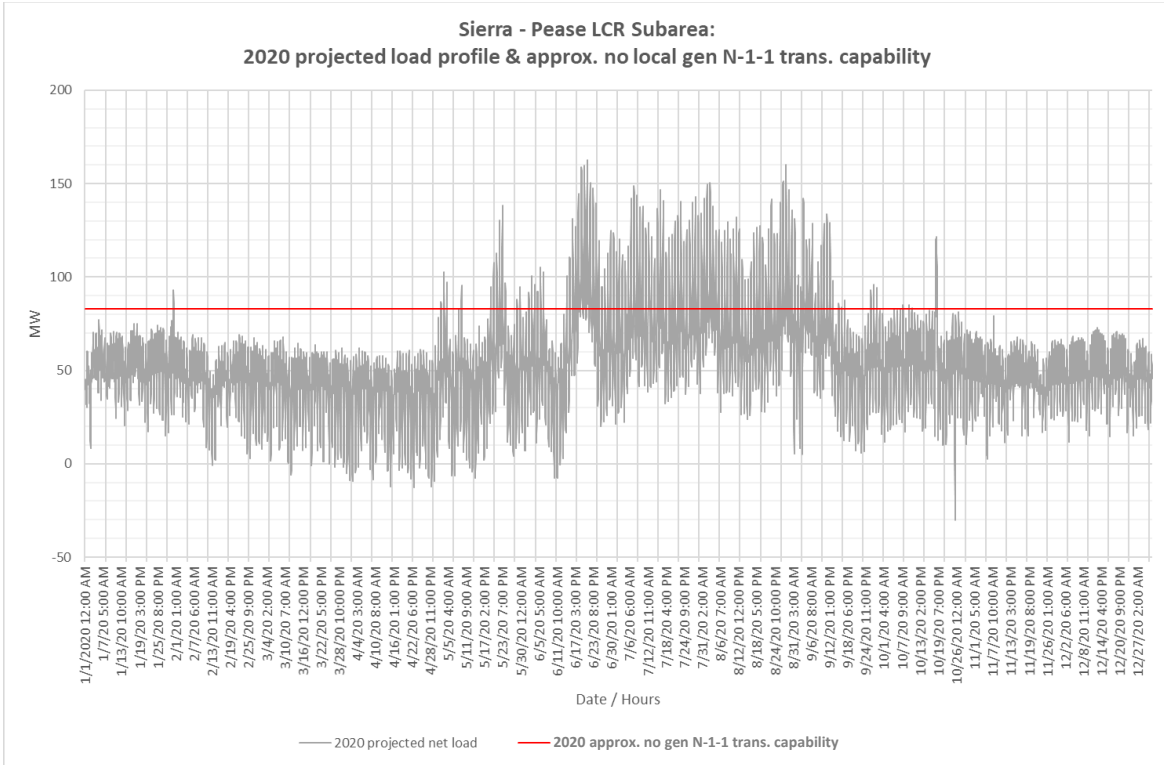

Figure 3.3-19 Pease LCR Sub-area 2020 Forecast Hourly Profiles



3.3.3.4.4 Pease LCR Sub-area Requirement

Table 3.3-13 identifies the sub-area LCR requirements. The Category B (Single Contingency) LCR requirement is 59 MW and the LCR requirement for Category C (Multiple Contingency) is 88 MW.

Table 3.3-13 Pease LCR Sub-area Requirements

Year	Limit	Category	Limiting Facility	Contingency	LCR (MW) (Deficiency)
2020	First Limit	B	Table Mountain – Pease 60 kV	Palermo-Pease 115 kV with Yuba City out of service	59
2020	First Limit	C	Table Mountain – Pease 60 kV	Palermo – Pease 115 kV and Pease – Rio Oso 115 kV	88

3.3.3.4.5 Effectiveness factors:

All units within the Pease Sub-area have the same effectiveness factor.

For most helpful procurement information please read procedure 2210Z Effectiveness Factors under 7230 posted at: <http://www.cao.com/Documents/2210Z.pdf>

3.3.3.5 Drum-Rio Oso Sub-area

Drum-Rio Oso is a Sub-area of the Sierra LCR Area.

3.3.3.5.1 Drum-Rio Oso LCR Sub-area Diagram

Figure 3.3-20 Drum-Rio Oso LCR Sub-area

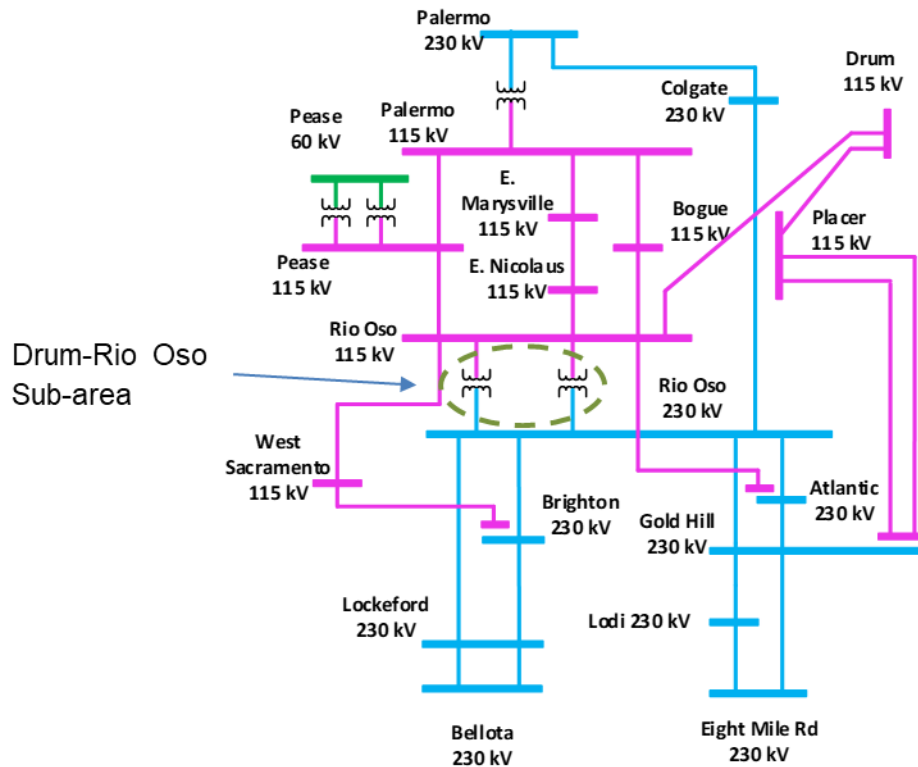

3.3.3.5.2 Drum-Rio Oso LCR Sub-area Load and Resources

The Drum-Rio Oso Sub-area does not have a defined load pocket with the limits based upon power flow through the area. Table 3.3-14 provides the forecasted resources in the sub-area. The list of generators within the LCR area are provided in Attachment A.

Table 3.3-14 Drum-Rio Oso LCR Sub-area 2020 Forecast Load and Resources

Load (MW)	Generation (MW)	NQC	At Peak
The Drum-Rio Oso Sub-area does not have a defined load pocket with the limits based upon power flow through the area.	Market and Net Seller	454	454
	MUNI	196	196
	QF	39	39
	Solar	6	0
	Existing 20-minute Demand Response	0	0

	Mothballed	0	0
	Total	695	689

3.3.3.5.3 Drum-Rio Oso LCR Sub-area Hourly Profiles

Figure 3.3-21 illustrates the 2020 Category C (Multiple Contingency) post contingency flows on the limiting facility for the summer peak, winter peak and spring off-peak days for the Drum-Rio Oso Sub-area transmission capability without resources. Figure 3.3-22 illustrates the 2020 hourly profile of the Category C (Multiple Contingency) post contingency flows on the limiting facility for Drum-Rio Oso LCR Sub-area without resources.

Figure 3.3-21 Drum-Rio Oso LCR Sub-area 2020 Limiting Post Contingency Peak Day Profiles

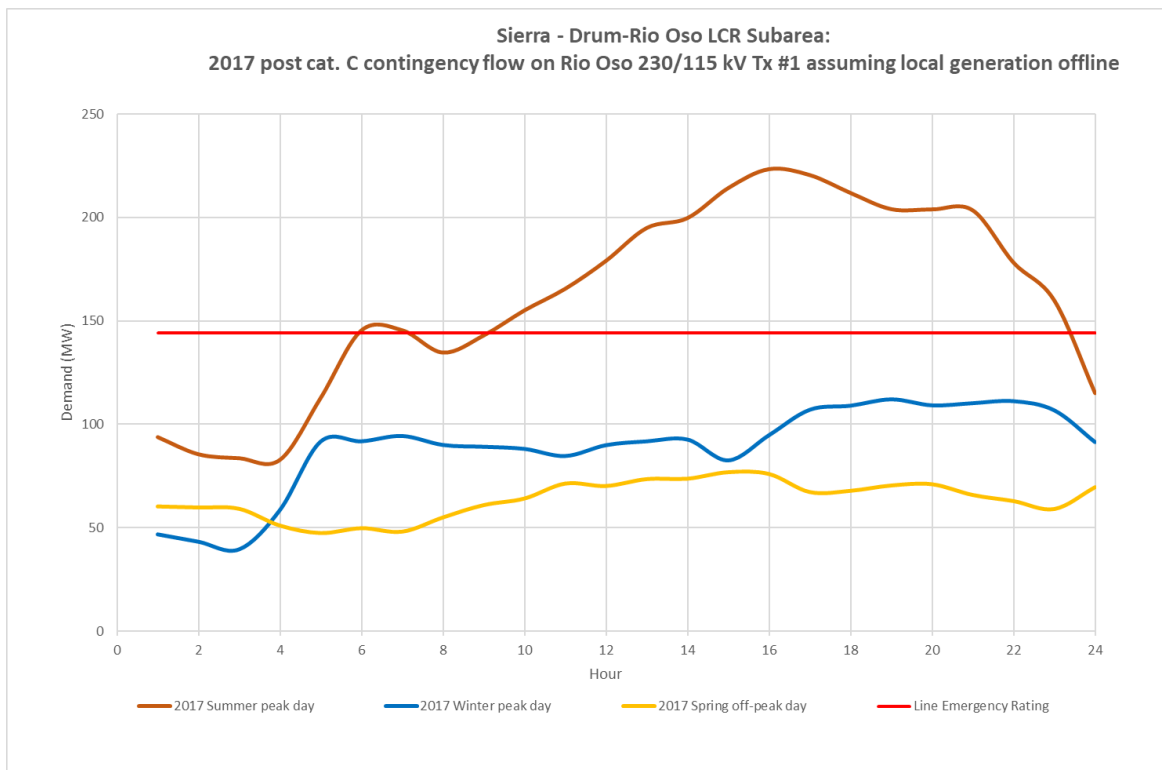
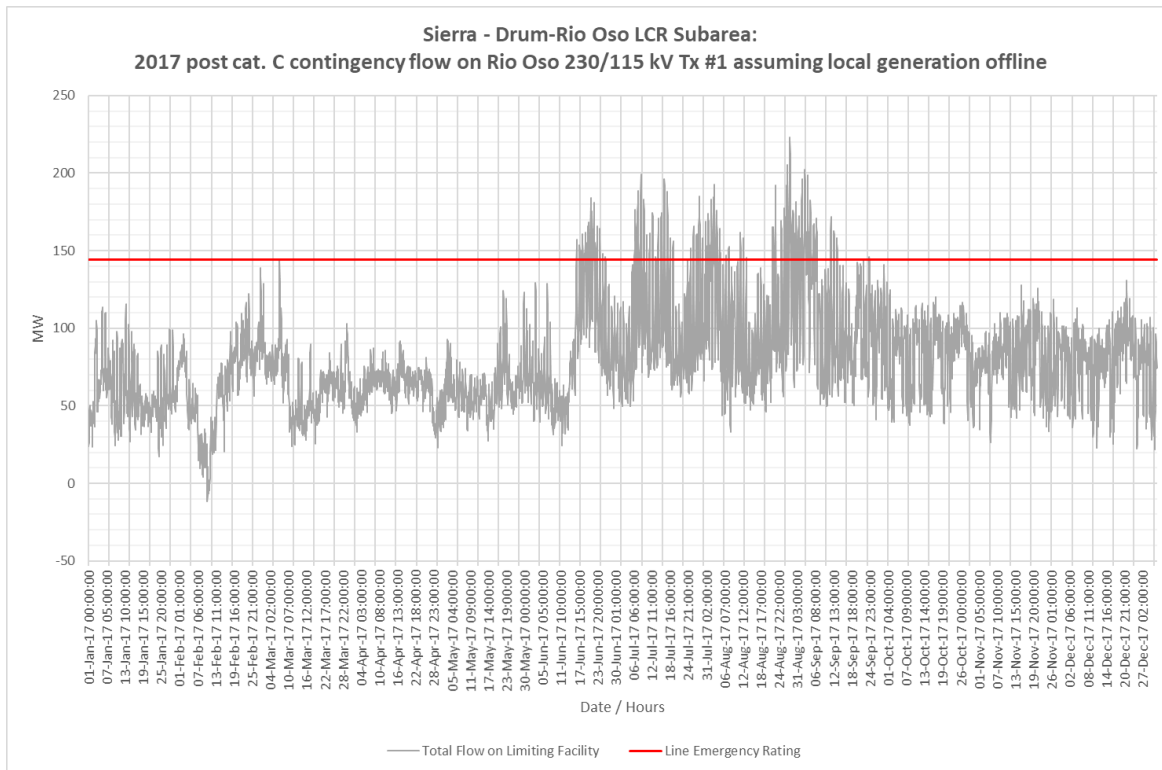

Figure 3.3-22 Drum-Rio Oso LCR Sub-area 2017 Limiting Post Contingency Hourly Profiles



3.3.3.5.4 Drum-Rio Oso LCR Sub-area Requirement

Table 3.3-15 identifies the sub-area LCR requirements. The Category B (Single Contingency) LCR requirement is 429 MW and the LCR requirement for Category C (Multiple Contingency) is 734 MW including 39 MW of NQC deficiency or 45 MW of at peak deficiency.

Table 3.3-15 Drum-Rio Oso LCR Sub-area Requirements

Year	Limit	Category	Limiting Facility	Contingency	LCR (MW) (Deficiency)
2020	First Limit	B	Rio Oso #2 230/115 kV Tx	Palermo #2 230/115 kV Tx	429
2020	First Limit	C	Rio Oso #1 230/115 kV Tx	Rio Oso #2 230/115 kV Tx & Rio Oso-Brighton 230 kV	734 (39 NQC/ 45 Peak)

3.3.3.5.5 Effectiveness factors

All units within the Drum-Rio Oso Sub-area have the same effectiveness factor.

For most helpful procurement information please read procedure 2210Z Effectiveness Factors under 7240 posted at: <http://www.caiso.com/Documents/2210Z.pdf>

3.3.3.6 South of Rio Oso Sub-area

South of Rio Oso is Sub-area of the Sierra LCR Area.

3.3.3.6.1 South of Rio Oso LCR Sub-area Diagram

Figure 3.3-23 South of Rio Oso LCR Sub-area

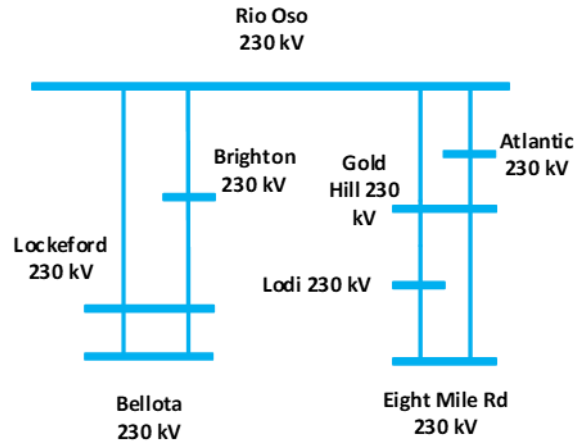

3.3.3.6.2 South of Rio Oso LCR Sub-area Load and Resources

The South of Rio Oso Sub-area does not have a defined load pocket with the limits based upon power flow through the area. Table 3.3-16 provides the forecasted resources in the sub-area. The list of generators within the LCR area are provided in Attachment A.

Table 3.3-16 South of Rio Oso LCR Sub-area 2020 Forecast Load and Resources

Load (MW)	Generation (MW)	NQC	At Peak
The South of Rio Oso Sub-area does not have a defined load pocket with the limits based upon power flow through the area.	Market and Net Seller	123	123
	MUNI	621	621
	QF	0	0
	Solar	0	0
	Existing 20-minute Demand Response	0	0
	Mothballed	0	0
	Total		743

3.3.3.6.3 South of Rio Oso LCR Sub-area Hourly Profiles

Figure 3.3-24 illustrates the 2017 Category C (Multiple Contingency) post contingency flows on the limiting facility for the summer peak, winter peak and spring off-peak days for the South of Rio Oso Sub-area transmission capability without resources. Figure 3.3-25 illustrates the 2017 hourly

profile of the Category C (Multiple Contingency) post contingency flows on the limiting facility for South of Rio Oso LCR Sub-area without resources.

Figure 3.3-24 South of Rio Oso LCR Sub-area 2017 Limiting Post Contingency Peak Day Profiles

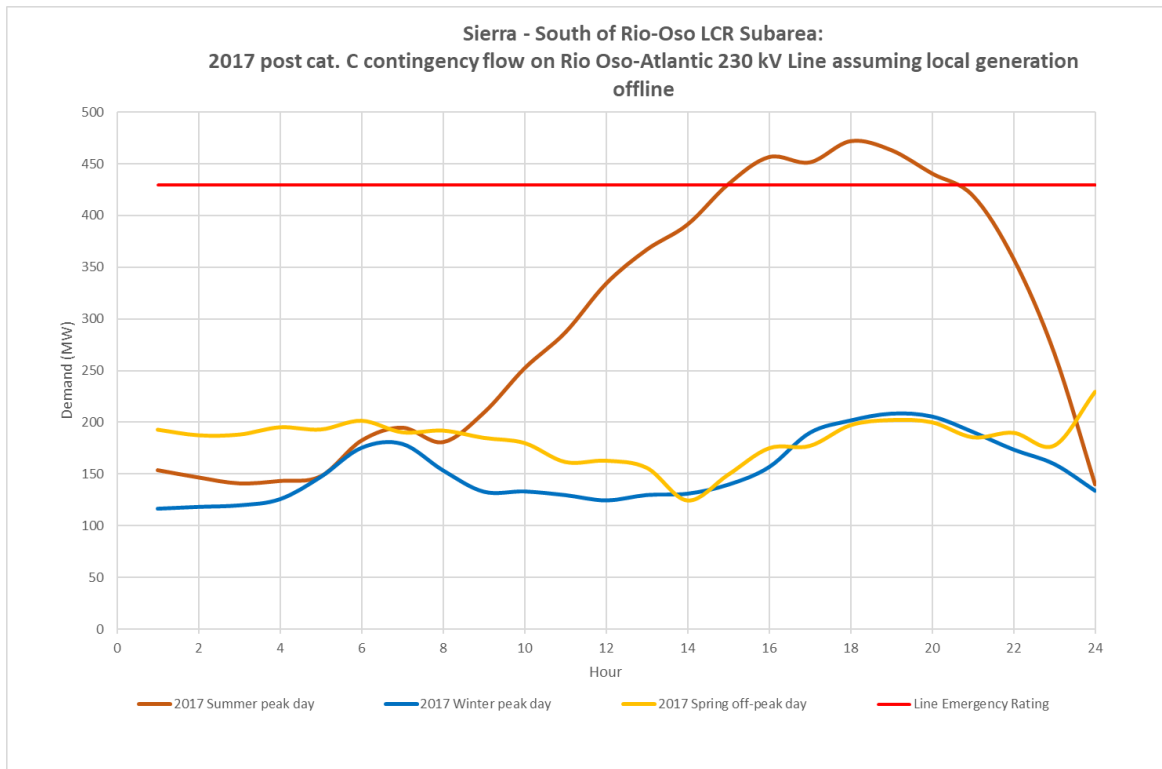
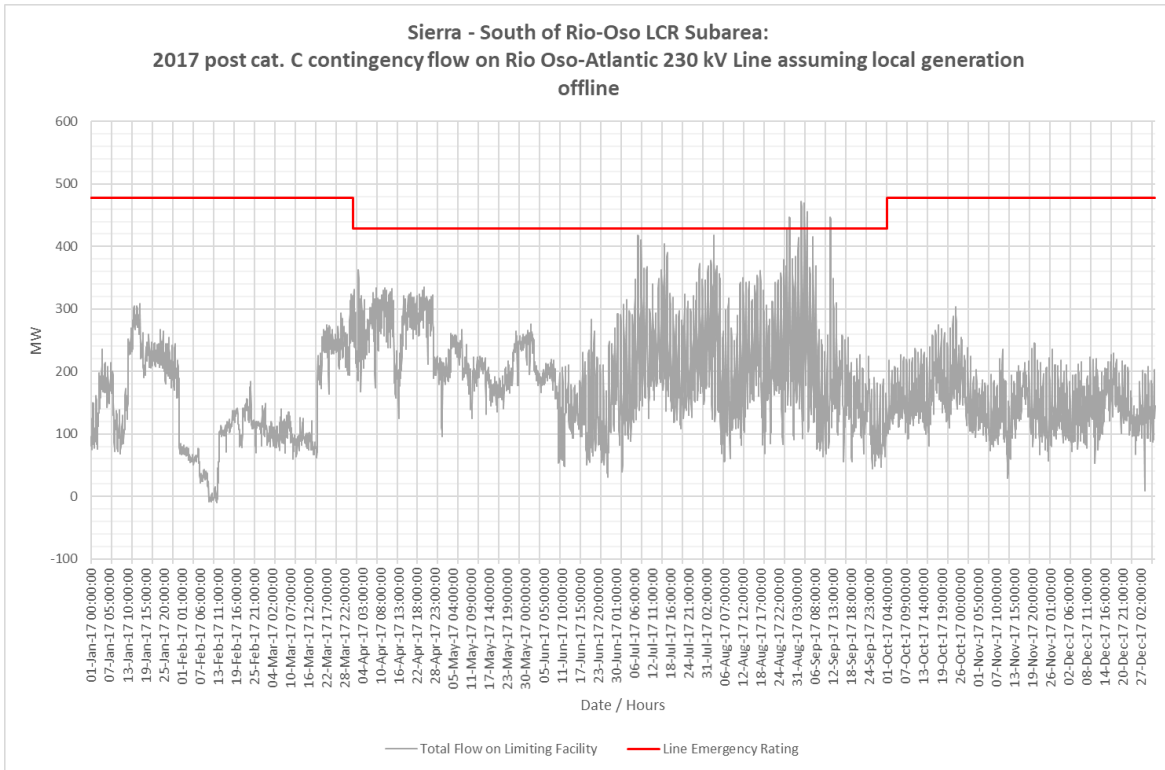

Figure 3.3-25 South of Rio Oso LCR Sub-area 2017 Limiting Post Contingency Hourly Profiles



3.3.3.6.4 South of Rio Oso LCR Sub-area Requirement

Table 3.3-17 identifies the sub-area LCR requirements. The LCR requirement for Category B (Single Contingency) is 276 MW and for Category C (Multiple Contingency) is 831 MW including 88 MW of NQC and at peak deficiency.

Table 3.3-17 South of Rio Oso LCR Sub-area Requirements

Year	Limit	Category	Limiting Facility	Contingency	LCR (MW) (Deficiency)
2020	First limit	B	Rio Oso – Atlantic 230 kV	Rio Oso – Gold Hill 230 kV & Ralston Unit	276
2020	First limit	C	Rio Oso – Brighton 230 kV	Rio Oso – Gold Hill 230 kV Rio Oso – Atlantic 230 kV	831 (88)

3.3.3.6.5 Effectiveness factors:

Effective factors for generators in the South of Rio Oso LCR Sub-area are in Attachment B table titled [Rio Oso](#).

For other helpful procurement information please read procedure 2210Z Effectiveness Factors under 7230 (T-165Z) posted at: <http://www.caiso.com/Documents/2210Z.pdf>

3.3.3.7 South of Palermo Sub-area

South of Palermo is a Sub-area of the Sierra LCR Area.

3.3.3.7.1 South of Palermo LCR Sub-area Diagram

Figure 3.3-26 South of Palermo LCR Sub-area

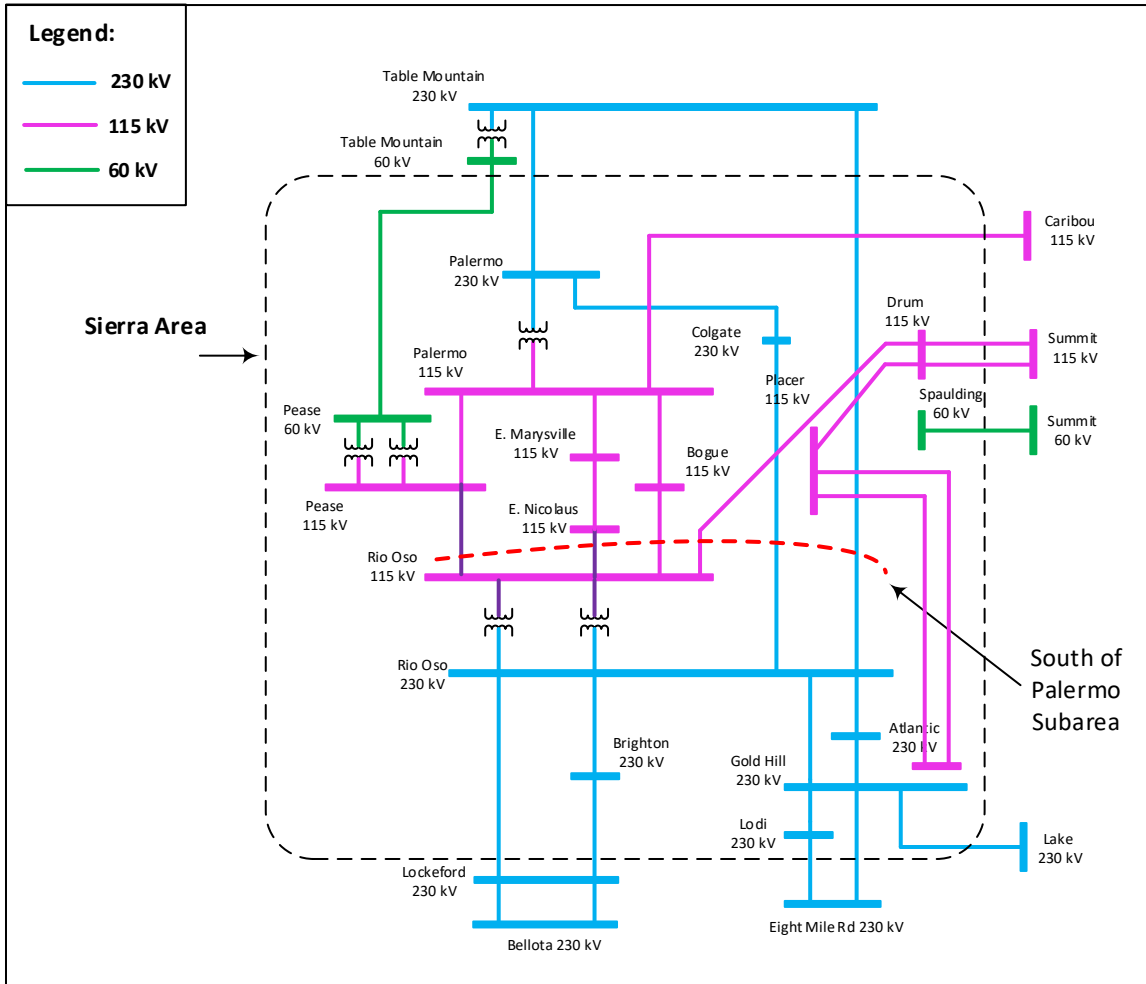

3.3.3.7.2 South of Palermo LCR Sub-area Load and Resources

The South of Palermo Sub-area does not have a defined load pocket with the limits based upon power flow through the area. Table 3.3-18 provides the forecasted resources in the sub-area. The list of generators within the LCR area are provided in Attachment A.

Table 3.3-18 South of Palermo LCR Sub-area 2020 Forecast Load and Resources

Load (MW)	Generation (MW)	NQC	At Peak
-----------	-----------------	-----	---------

The South of Palermo Sub-area does not have a defined load pocket with the limits based upon power flow through the area.	Market and Net Seller	754	754
	MUNI	666	666
	QF	1	1
	Solar	6	0
	Existing 20-minute Demand Response	0	0
	Mothballed	0	0
	Total	1427	1421

3.3.3.7.3 South of Palermo LCR Sub-area Hourly Profiles

Figure 3.3-27 illustrates the 2017 Category C (Multiple Contingency) post contingency flows on the limiting facility for the summer peak, winter peak and spring off-peak days for the South of Palermo Sub-area transmission capability without resources. Figure 3.3-28 illustrates the 2017 hourly profile of the Category C (Multiple Contingency) post contingency flows on the limiting facility for South of Palermo LCR Sub-area without resources.

Figure 3.3-27 South of Palermo LCR Sub-area 2017 Limiting Post Contingency Peak Day Profiles

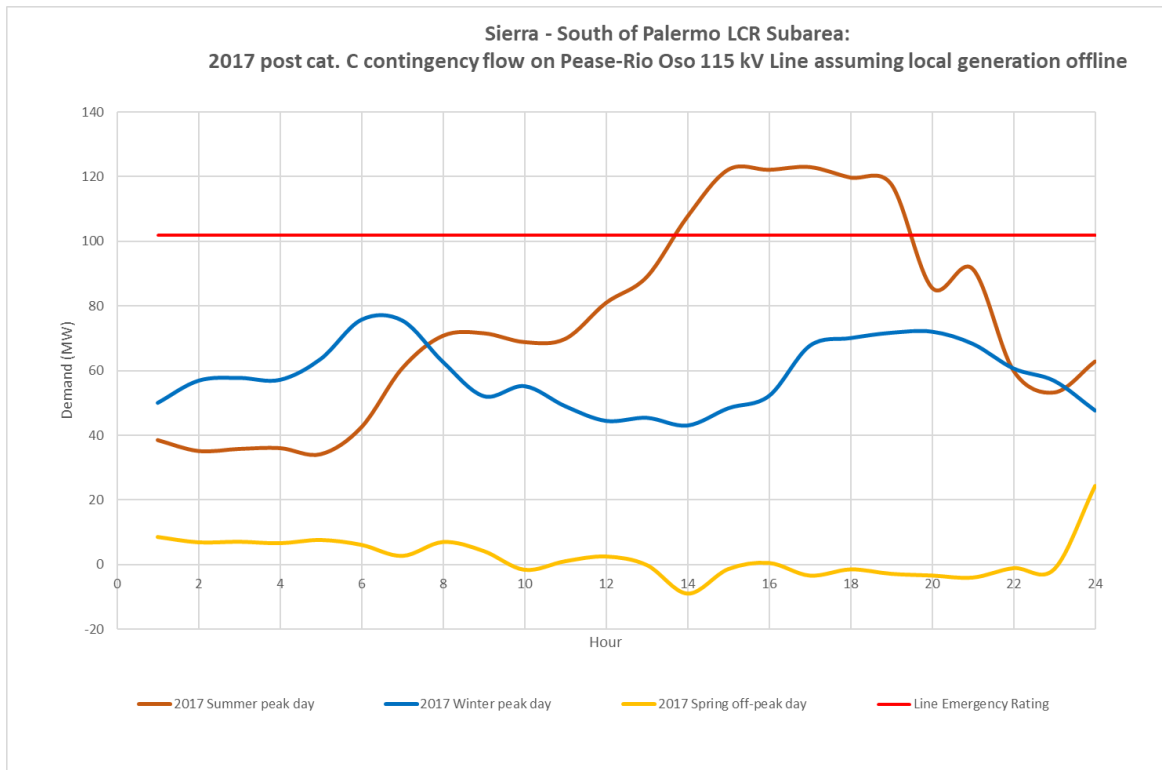
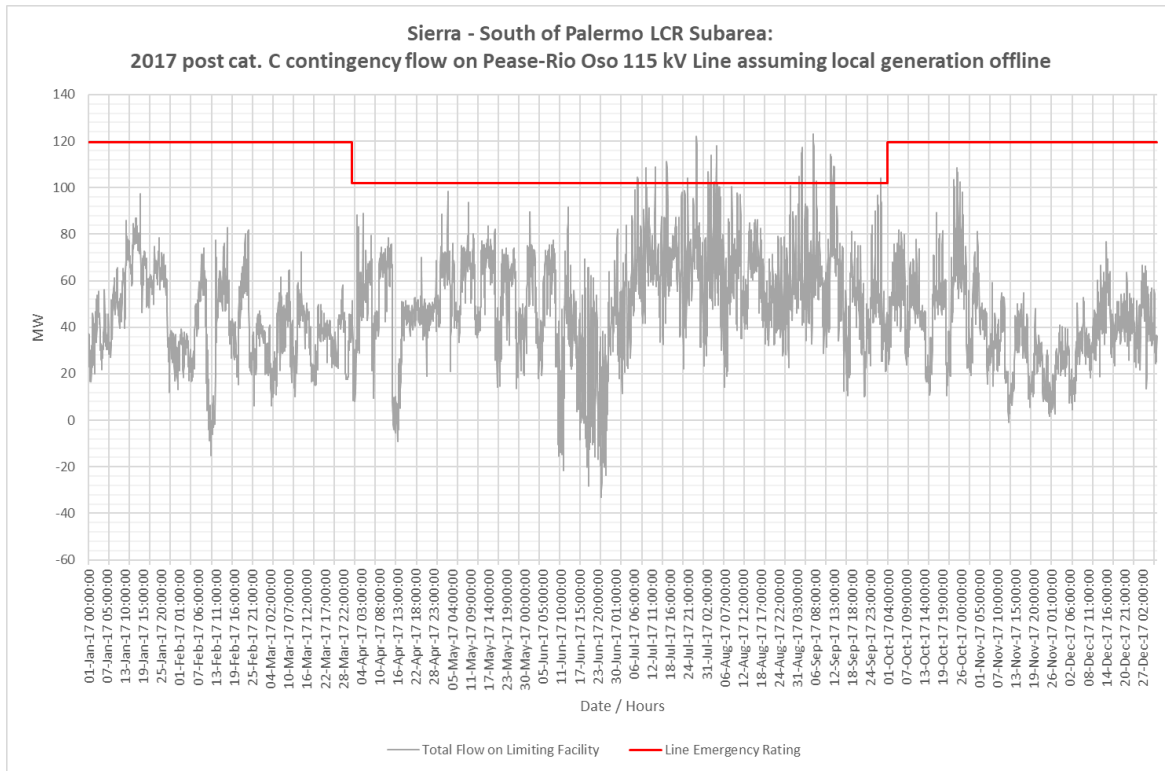

Figure 3.3-28 South of Palermo LCR Sub-area 2017 Limiting Post Contingency Hourly Profiles



3.3.3.7.4 South of Palermo LCR Sub-area Requirement

Table 3.3-19 identifies the sub-area requirements. The LCR requirement for Category B (Single Contingency) is 1091 MW and for Category C (Multiple Contingency) is 1569 MW including 142 MW of NQC deficiency or 148 MW of at peak deficiency.

Table 3.3-19 South of Palermo LCR Sub-area Requirements

Year	Limit	Category	Limiting Facility	Contingency	LCR (MW) (Deficiency)
2020	First limit	B	Pease-Rio Oso 115 kV	Table Mountain-Rio Oso 230 kV & Belden Unit	1091
2020	First limit	C	Pease-Rio Oso 115 kV	Table Mountain-Rio Oso 230 kV Colgate-Rio Oso 230 kV	1569 (142 NQC/ 148 Peak)

3.3.3.7.5 Effectiveness factors:

All resources within the South of Palermo are needed therefore no effectiveness factor is required.

For other helpful procurement information please read procedure 2210Z Effectiveness Factors under 7230 (T-165Z) posted at: <http://www.caiso.com/Documents/2210Z.pdf>

3.3.3.8 Sierra Area Overall

3.3.3.8.1 Sierra LCR Area Hourly Profiles

Figure 3.3-29 illustrates the 2017 Category C (Multiple Contingency) post contingency flows on the limiting facility for the summer peak, winter peak and spring off-peak days for the Sierra Area transmission capability without resources. Figure 3.3-30 illustrates the 2017 hourly profile of the Category C (Multiple Contingency) post contingency flows on the limiting facility for Sierra LCR Area without resources.

Figure 3.3-29 Sierra Area 2017 Limiting Post Contingency Peak Day Profiles

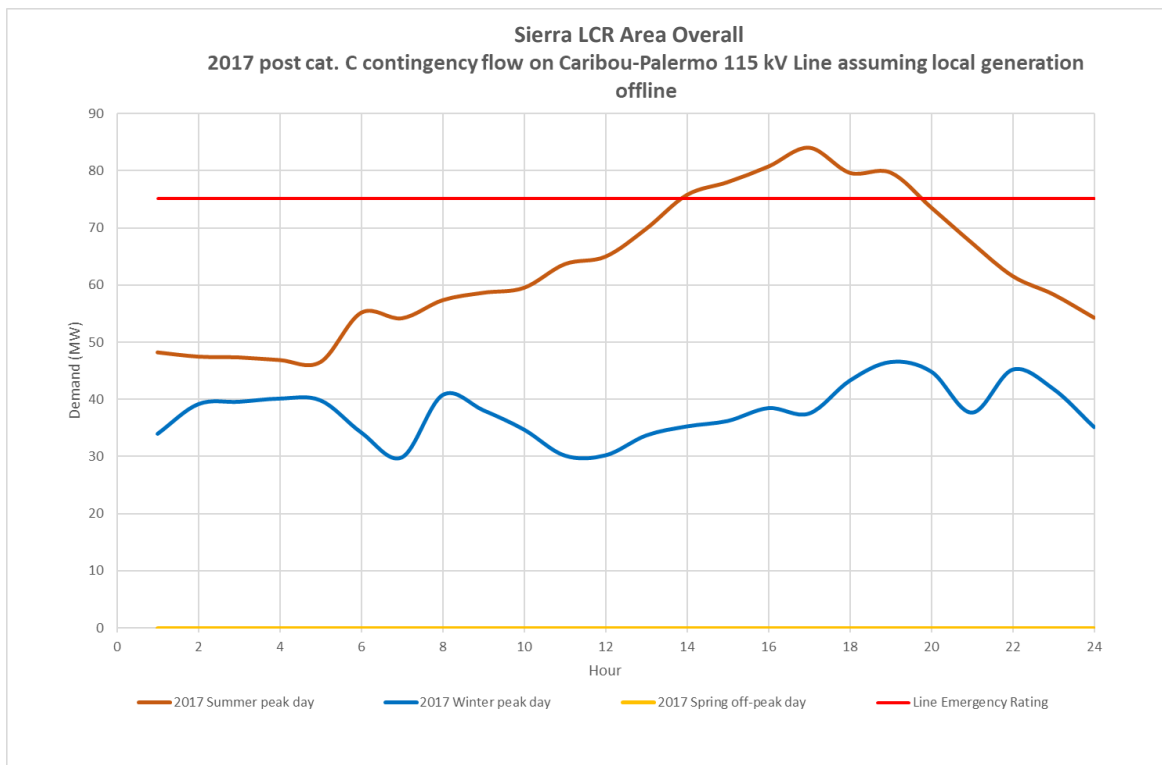
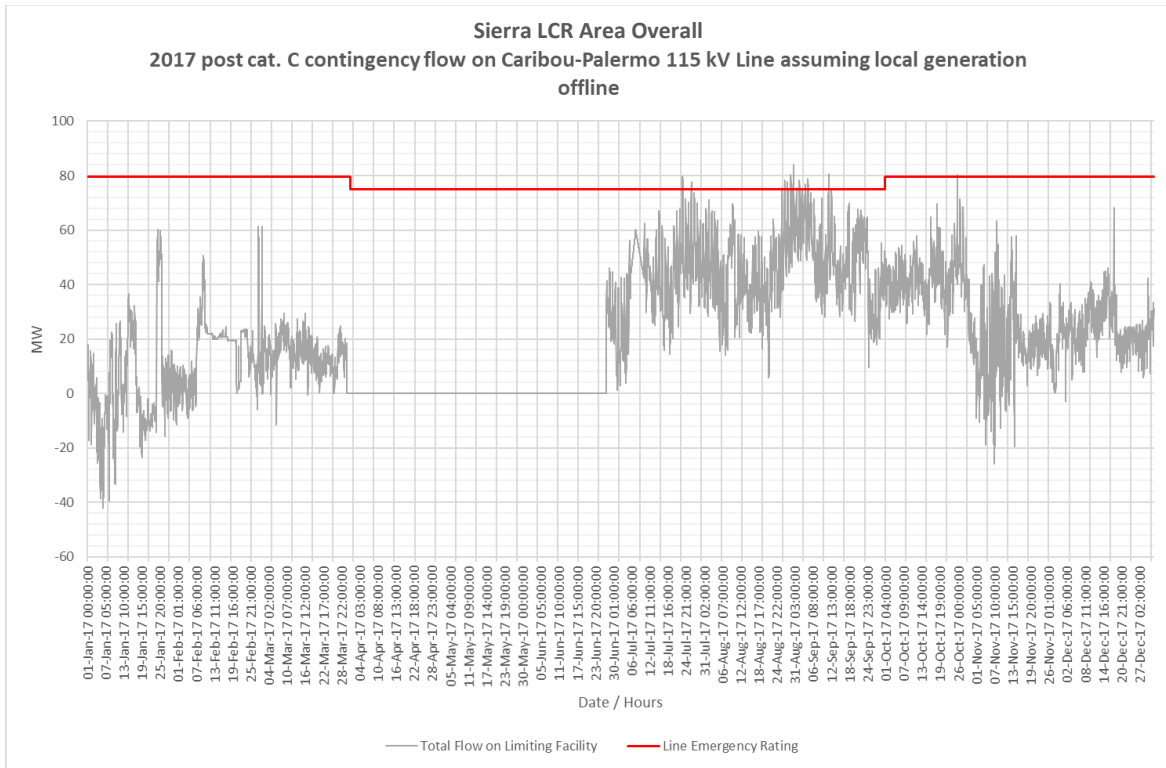

Figure 3.3-30 Sierra Area 2017 Limiting Post Contingency Hourly Profiles



3.3.3.8.2 Sierra LCR Area Requirement

Table 3.3-20 identifies the sub-area requirements. The LCR requirement for Category B (Single Contingency) is non-binding and for Category C (Multiple Contingency) is 1764 MW.

Table 3.3-20 Sierra LCR Area Requirements

Year	Limit	Category	Limiting Facility	Contingency	LCR (MW) (Deficiency)
2020	First limit	B	Non-binding.	Non-binding.	N/A
2020	First limit	C	Table Mountain – Pease 60 kV	Table Mountain – Palermo 230 kV Table Mountain – Rio Oso 230 kV	1764

3.3.3.8.3 Effectiveness factors:

Effective factors for generators in the South of Table Mountain LCR Sub-area are in Attachment B table titled [South of Table Mountain](#).

For other helpful procurement information please read procedure 2210Z Effectiveness Factors under 7230 (T-165Z) posted at: <http://www.caiso.com/Documents/2210Z.pdf>

3.3.3.8.4 Changes compared to last year’s results:

The load forecast went up by 104 MW and the total LCR need has decreased by 200 MW due to transmission development.

3.3.4 Stockton Area

The LCR requirement for the Stockton Area is driven by the sum of the requirements for the Tesla-Bellota, Lockeford and Weber sub-areas. Area Definition:

Tesla-Bellota Sub-Area Definition

The transmission facilities that establish the boundary of the Tesla-Bellota sub-area are:

- Bellota 230/115 kV Transformer #1
- Bellota 230/115 kV Transformer #2
- Tesla-Tracy 115 kV Line
- Tesla-Salado 115 kV Line
- Tesla-Salado-Manteca 115 kV line
- Tesla-Schulte #1 115 kV Line
- Tesla-Schulte #2 115kV line

The substations that delineate the Tesla-Bellota Sub-area are:

- Bellota 230 kV is out Bellota 115 kV is in
- Bellota 230 kV is out Bellota 115 kV is in
- Tesla is out Tracy is in
- Tesla is out Salado is in
- Tesla is out Salado and Manteca are in
- Tesla is out Schulte is in
- Tesla is out Schulte is in

Lockeford Sub-Area Definition

The transmission facilities that establish the boundary of the Lockeford Sub-area are:

- Lockeford-Industrial 60 kV line
- Lockeford-Lodi #1 60 kV line
- Lockeford-Lodi #2 60 kV line
- Lockeford-Lodi #3 60 kV line

The substations that delineate the Lockeford Sub-area are:

- Lockeford is out Industrial is in
- Lockeford is out Lodi is in

- Lockeford is out Lodi is in
- Lockeford is out Lodi is in

Weber Sub-Area Definition

The transmission facilities that establish the boundary of the Weber Sub-area are:

- Weber 230/60 kV Transformer #1
- Weber 230/60 kV Transformer #2

The substations that delineate the Weber Sub-area are:

- Weber 230 kV is out Weber 60 kV is in
- Weber 230 kV is out Weber 60 kV is in

3.3.4.1.1 Stockton LCR Area Diagram

The Stockton LCR Area is comprised of the individual noncontiguous Sub-areas with diagrams provided for each of the Sub-areas below.

3.3.4.1.2 Stockton LCR Area Load and Resources

Table 3.3-21 provides the forecast load and resources in the area. The list of generators within the LCR area are provided in Attachment A.

In year 2020 the estimated time of local area peak is 19:10 PM.

At the local area peak time the estimated, behind the meter, solar output is 0.00%.

At the local area peak time the estimated, ISO metered, solar output is 2.00%.

If required, all non-solar technology type resources are dispatched at NQC.

Table 3.3-21 Stockton LCR Area 2020 Forecast Load and Resources

Load (MW)		Generation (MW)	NQC	At Peak
Gross Load	1270	Market and Net Seller	497	497
AAEE	-16	MUNI	137	137
Behind the meter DG	0	QF	18	18
Net Load	1254	Solar	1	0
Transmission Losses	21	Existing 20-minute Demand Response	0	0
Pumps	0	Mothballed	0	0
Load + Losses + Pumps	1275	Total	653	652

3.3.4.1.3 Stockton LCR Area Hourly Profiles

The Stockton LCR Area is comprised of the individual noncontiguous Sub-areas with profiles provided for each of the Sub-areas below.

3.3.4.1.4 Approved transmission projects modeled

- Weber-Stockton “A” #1 and #2 60 kV Reconductoring
- Ripon 115 kV line

3.3.4.2 Weber Sub-area

Weber is a Sub-area of the Stockton LCR Area.

3.3.4.2.1 Weber LCR Sub-area Diagram

Figure 3.3-31 Weber LCR Sub-area

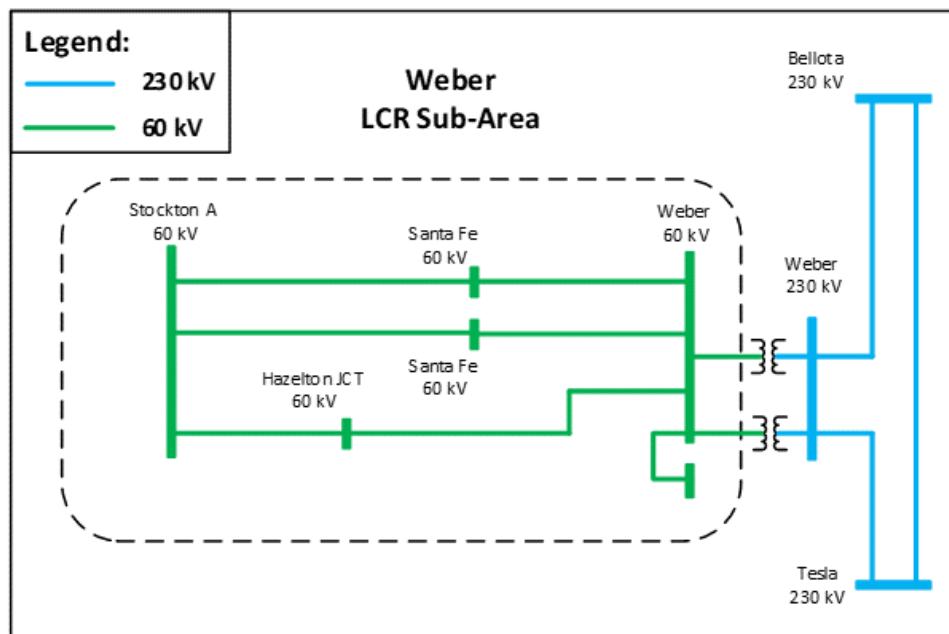

3.3.4.2.2 Weber LCR Sub-area Load and Resources

Table 3.3-22 provides the forecasted load and resources. The list of generators within the LCR Sub-area are provided in Attachment A.

Table 3.3-22 Weber LCR Sub-area 2020 Forecast Load and Resources

Load (MW)		Generation (MW)	NQC	At Peak
Gross Load	239	Market	49	49
AAEE	-3	MUNI	0	0
Behind the meter DG	0	QF	1	1

Net Load	236	Solar	0	0
Transmission Losses	2	Existing 20-minute Demand Response	0	0
Pumps	0	Mothballed	0	0
Load + Losses + Pumps	238	Total	50	50

3.3.4.2.3 Weber LCR Sub-area Hourly Profiles

Figure 3.3-32 illustrates the forecast 2020 profile for the summer peak, winter peak and spring off-peak days for the Weber LCR Sub-area with the Category C (Multiple Contingency) transmission capability without resources. Figure 3.3-33 illustrates the forecast 2020 hourly profile for Weber LCR Sub-area with the Category C (Multiple Contingency) transmission capability without resources.

Figure 3.3-32 Weber LCR Sub-area 2020 Peak Day Forecast Profiles



Figure 3.3-33 Weber LCR Sub-area 2020 Forecast Hourly Profiles

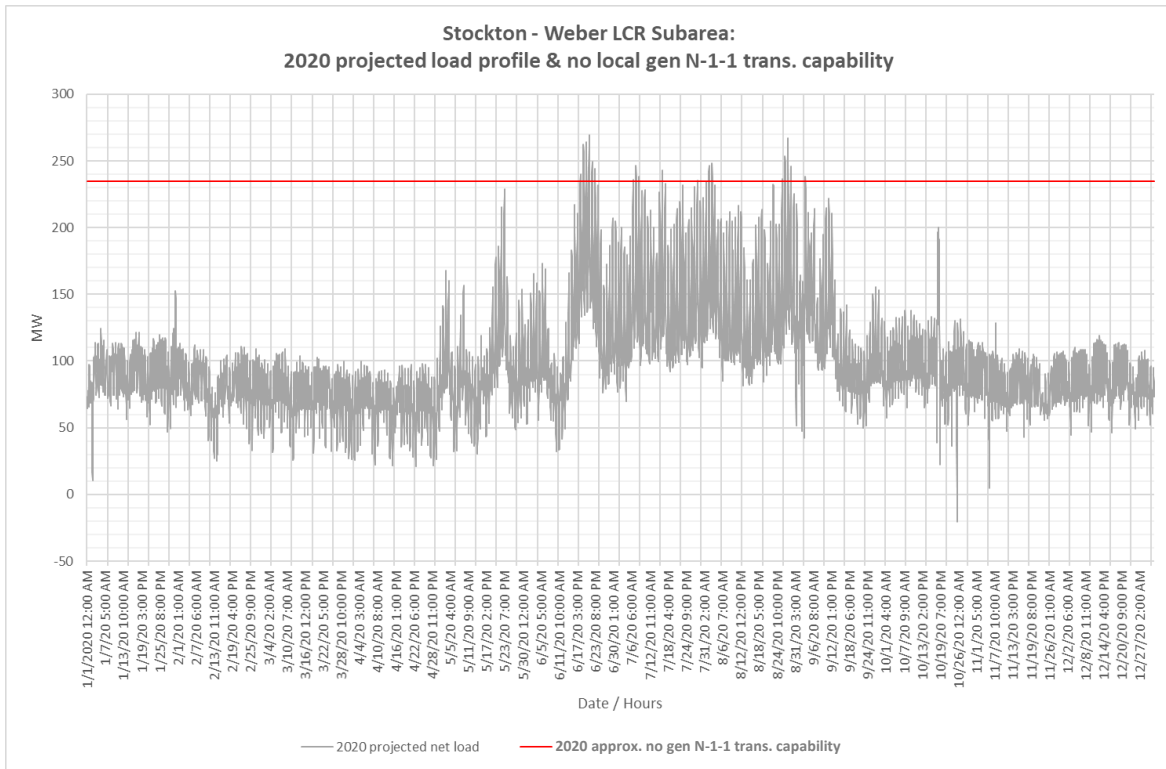

3.3.4.2.4 Weber LCR Sub-area Requirement

Table 3.3-23 identifies the sub-area requirements. There is no LCR requirement for Category B (Single Contingency) and the LCR Requirement for a Category C (Multiple Contingency) is 26 MW.

Table 3.3-23 Weber LCR Sub-area Requirements

Year	Limit	Category	Limiting Facility	Contingency	LCR (MW) (Deficiency)
2020	First Limit	B	None	None	0
2020	First Limit	C	Stockton A-Weber #3 60 kV	Stockton A-Weber #1 & #2 60 kV	26

3.3.4.2.5 Effectiveness factors:

All units within this sub-area have the same effectiveness factor.

For most helpful procurement information please read procedure 2210Z Effectiveness Factors under 7110 (T-138Z) posted at: <http://www.caiso.com/Documents/2210Z.pdf>

3.3.4.3 Lockeford Sub-area

Lockeford is a Sub-area of the Stockton LCR Area.

3.3.4.3.1 Lockeford LCR Sub-area Diagram

Figure 3.3-34 Lockeford LCR Sub-area

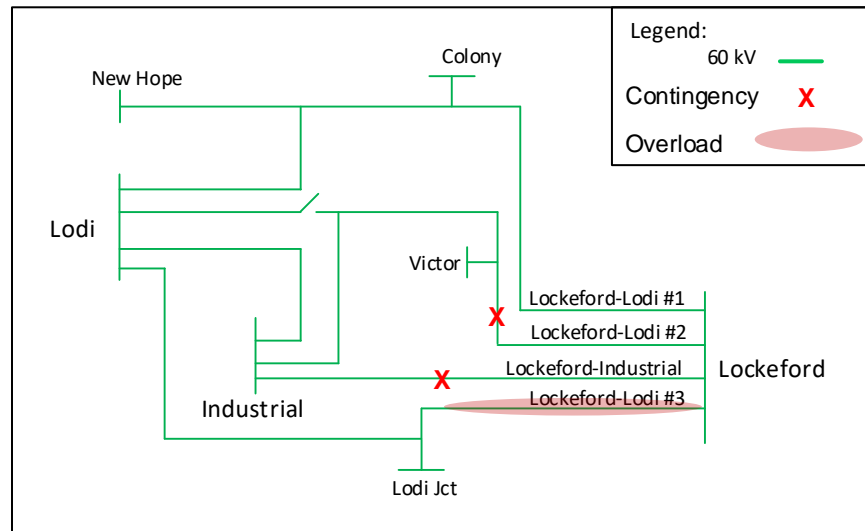

3.3.4.3.2 Lockeford LCR Sub-area Load and Resources

Table 3.3-24 provides the forecasted load and resources. The list of generators within the LCR Sub-area are provided in Attachment A.

Table 3.3-24 Lockeford LCR Sub-area 2020 Forecast Load and Resources

Load (MW)		Generation (MW)	NQC	At Peak
Gross Load	191	Market	0	0
AAEE	-3	MUNI	24	24
Behind the meter DG	0	QF	0	0
Net Load	188	Solar	0	0
Transmission Losses	2	Existing 20-minute Demand Response	0	0
Pumps	0	Mothballed	0	0
Load + Losses + Pumps	190	Total	24	24

3.3.4.3.3 Lockeford LCR Sub-area Hourly Profiles

Figure 3.3-35 illustrates the forecast 2020 profile for the summer peak, winter peak and spring off-peak days for the Lockeford LCR Sub-area with the Category C (Multiple Contingency) transmission capability without resources. Figure 3.3-36 illustrates the forecast 2020 hourly profile

for Lockeford LCR Sub-area with the Category C (Multiple Contingency) transmission capability without resources.

Figure 3.3-35 Lockeford LCR Sub-area 2020 Peak Day Forecast Profiles

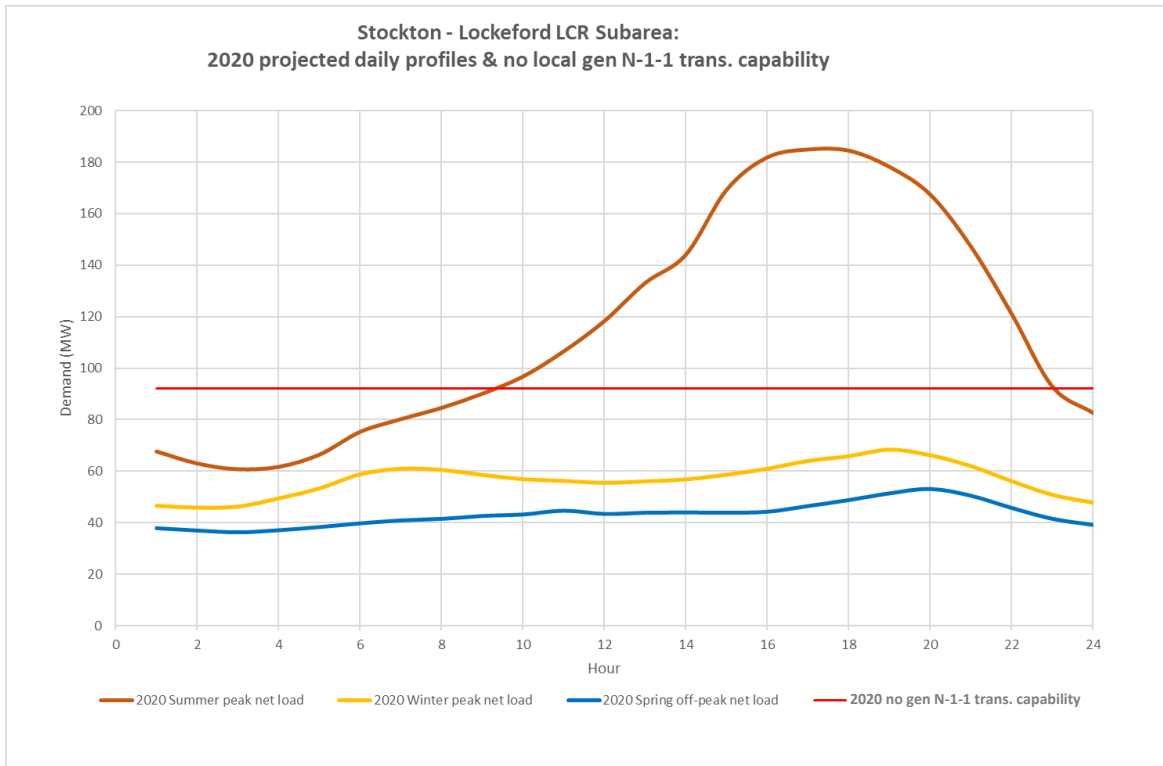
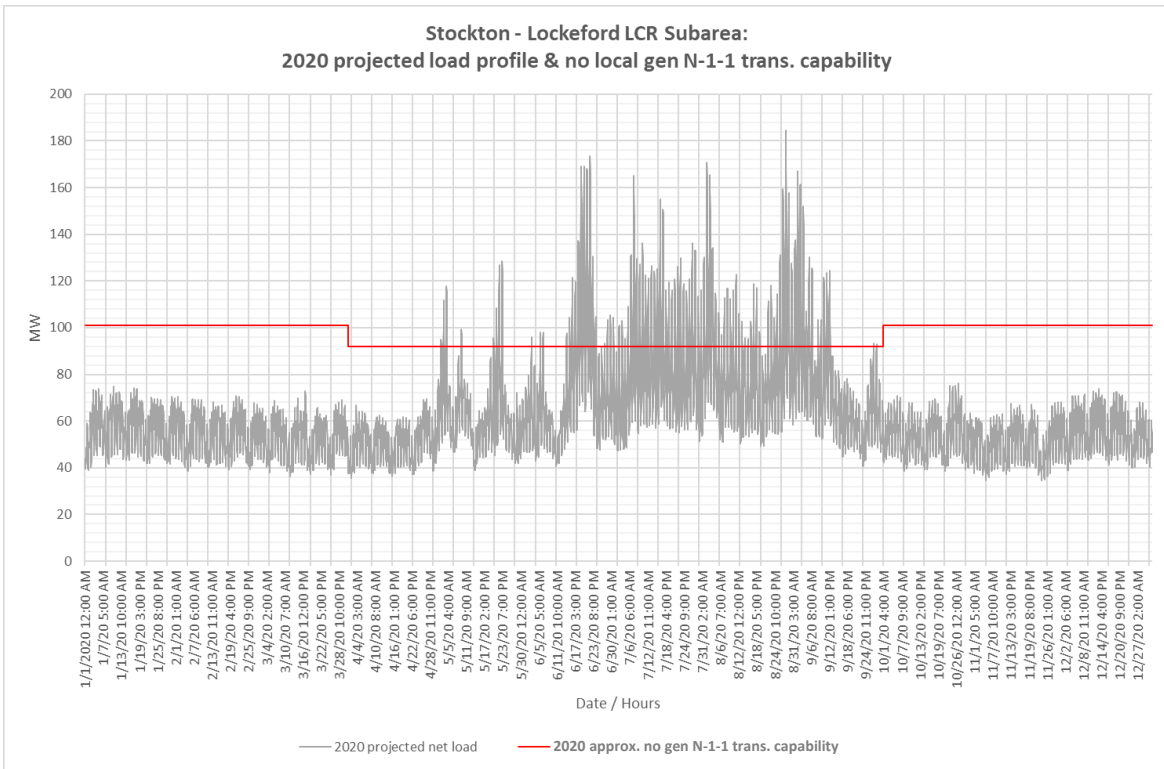

Figure 3.3-36 Lockeford LCR Sub-area 2020 Forecast Hourly Profiles



3.3.4.3.4 Lockeford LCR Sub-area Requirement

Table 3.3-25 identifies the sub-area requirements. The LCR requirement for Category B (Single Contingency) is 48 MW including 24 MW of NQC and at peak deficiency and the LCR Requirement for a Category C (Multiple Contingency) is 97 MW including 73 MW of NQC and at peak deficiency.

Table 3.3-25 Lockeford LCR Sub-area Requirements

Year	Limit	Category	Limiting Facility	Contingency	LCR (MW) (Deficiency)
2020	First Limit	B	Lockeford-Lodi #3 60 kV	Lockeford-Industrial 60 kV & Lodi CT	48 (24)
2020	First Limit	C	Lockeford-Lodi #3 60 kV	Lockeford-Industrial 60 kV & Lockeford-Lodi #2 60 kV	97 (73)

3.3.4.3.5 Effectiveness factors:

All units within this sub-area are needed therefore no effectiveness factor is required.

For most helpful procurement information please read procedure 2210Z Effectiveness Factors under 7110 (T-138Z) posted at: <http://www.caiso.com/Documents/2210Z.pdf>

3.3.4.4 Stanislaus Sub-area

Stanislaus is a Sub-area of the Stockton LCR Area.

3.3.4.4.1 Stanislaus LCR Sub-area Diagram

Figure 3.3-37 Stanislaus LCR Sub-area

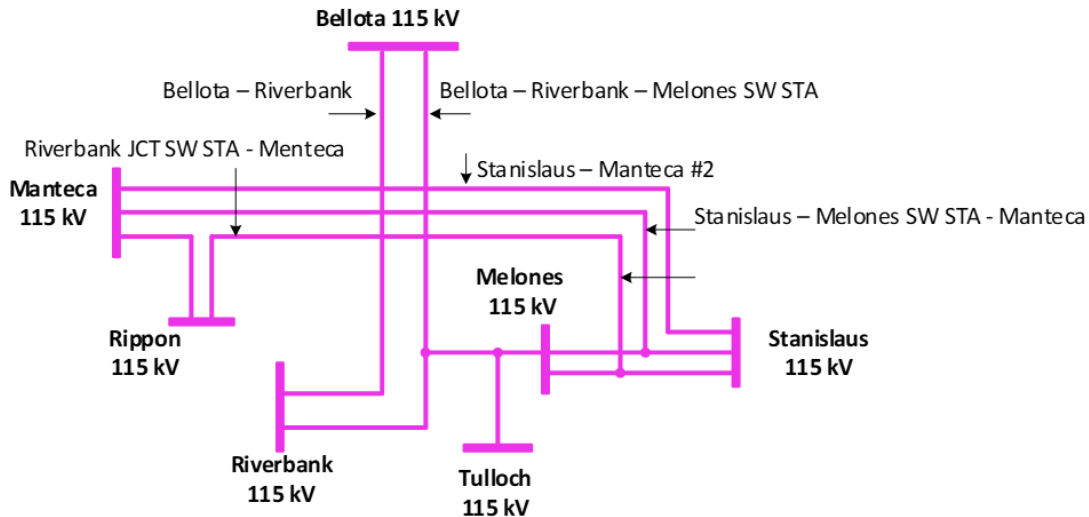

3.3.4.4.2 Stanislaus LCR Sub-area Load and Resources

The Stanislaus Sub-area does not have a defined load pocket with the limits based upon power flow through the area. Table 3.3-26 provides the forecasted resources in the sub-area. The list of generators within the LCR sub-area are provided in Attachment A.

Table 3.3-26 Stanislaus LCR Sub-area 2020 Forecast Load and Resources

Load (MW)	Generation (MW)	NQC	At Peak
The Stanislaus Sub-area does not have a defined load pocket with the limits based upon power flow through the area.	Market and Net Seller	100	100
	MUNI	94	94
	QF	16	16
	Solar	1	0
	Existing 20-minute Demand Response	0	0
	Mothballed	0	0
	Total		211

3.3.4.4.3 Stanislaus LCR Sub-area Hourly Profiles

Figure 3.3-38 illustrates the 2017 Category C (Multiple Contingency) post contingency flows on the limiting facility for the summer peak, winter peak and spring off-peak days for the Stanislaus Sub-area transmission capability without resources. Figure 3.3-39 illustrates the 2017 hourly profile of the Category C (Multiple Contingency) post contingency flows on the limiting facility for Stanislaus LCR Sub-area without resources.

Figure 3.3-38 Stanislaus LCR Sub-area 2017 Limiting Post Contingency Peak Day Profiles

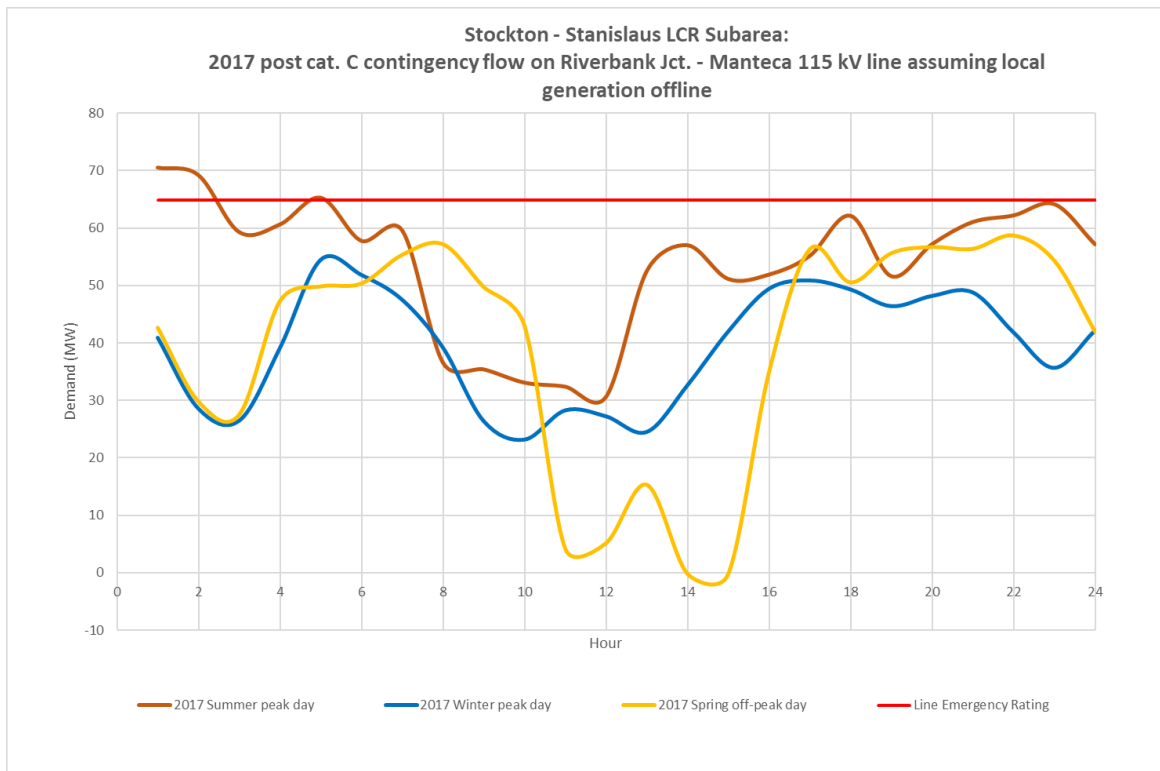
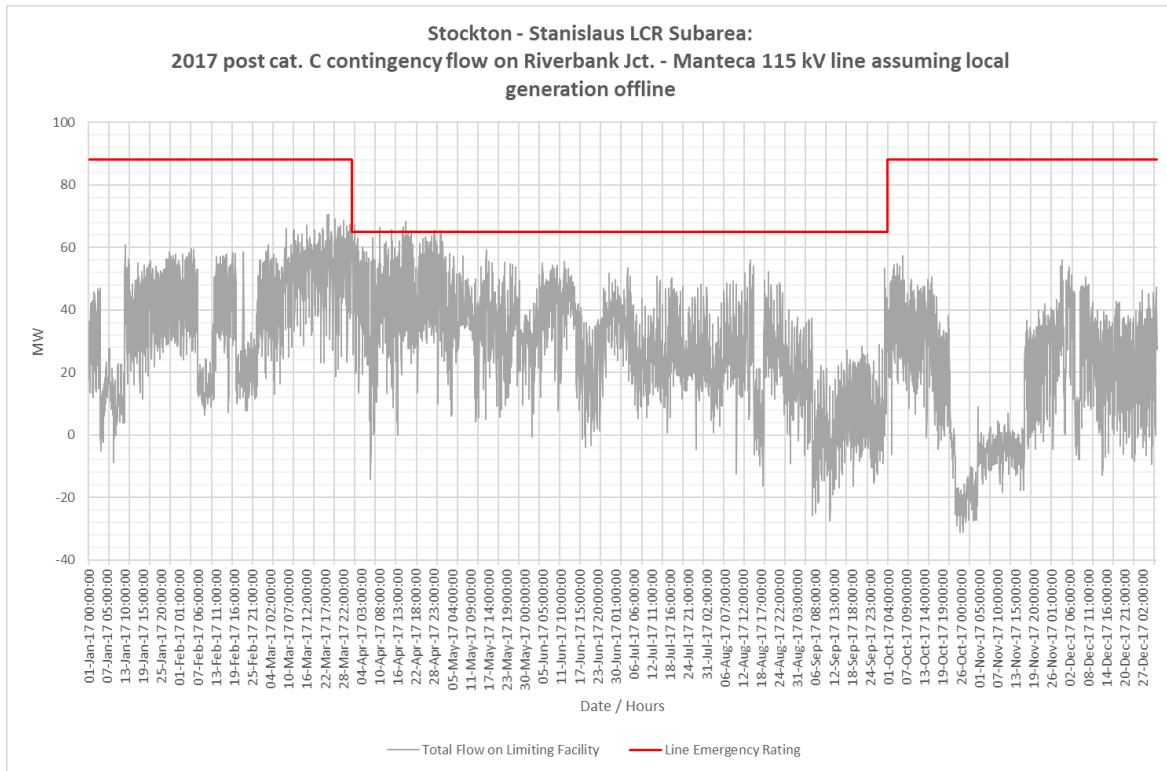

Figure 3.3-39 Stanislaus LCR Sub-area 2017 Limiting Post Contingency Hourly Profiles



3.3.4.4.4 Stanislaus LCR Sub-area Requirement

Table 3.3-27 identifies the sub-area requirements. The LCR requirement for Category B (Single Contingency) is 179 MW and Category C (Multiple Contingency) requirement is the same.

Table 3.3-27 Stanislaus LCR Sub-area Requirements

Year	Limit	Category	Limiting Facility	Contingency	LCR (MW) (Deficiency)
2020	First limit	B/C	River Bank Jct. – Manteca 115 kV	Bellota-Riverbank-Melones 115 kV and Stanislaus PH	179

3.3.4.4.5 Effectiveness factors:

All units within this sub-area have the same effectiveness factor.

For most helpful procurement information please read procedure 2210Z Effectiveness Factors under 7110 (T-138Z) posted at: <http://www.aiso.com/Documents/2210Z.pdf>

3.3.4.5 Tesla-Bellota Sub-area

Tesla-Bellota is a Sub-area of the Stockton LCR Area.

3.3.4.5.1 Tesla-Bellota LCR Sub-area Diagram

Figure 3.3-40 Tesla-Bellota LCR Sub-area

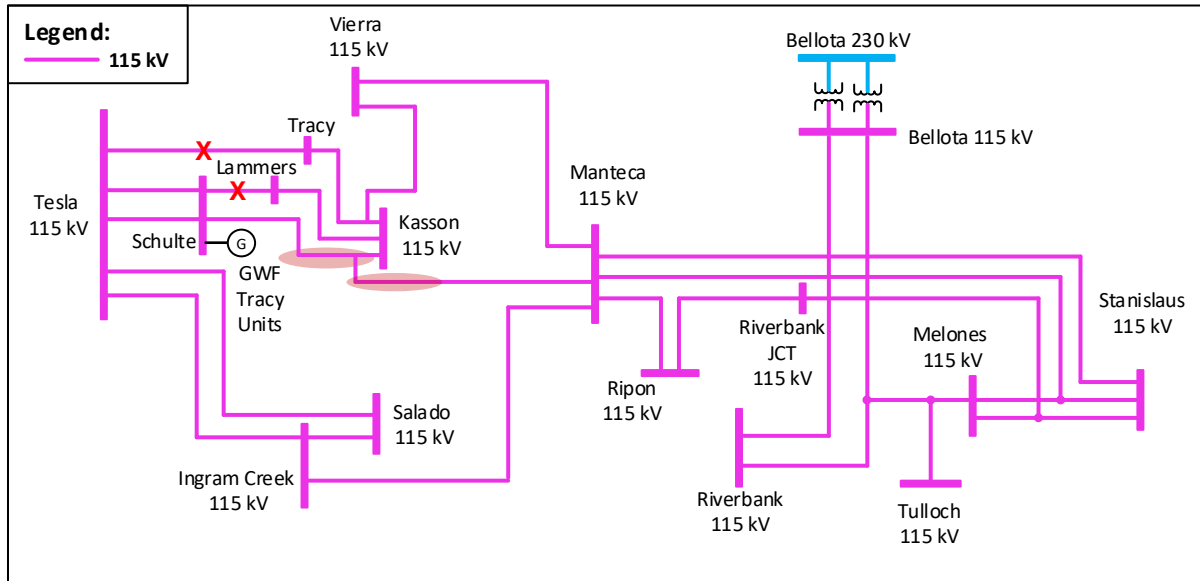

3.3.4.5.2 Tesla Bellota LCR Sub-area Load and Resources

Table 3.3-28 provides the forecasted load and resources. The list of generators within the LCR Sub-area are provided in Attachment A.

Table 3.3-28 Tesla-Bellota LCR Sub-area 2020 Forecast Load and Resources

Load (MW)		Generation (MW)	NQC	At Peak
Gross Load	840	Market and Net Seller	449	449
AAEE	-10	MUNI	113	113
Behind the meter DG	0	QF	16	16
Net Load	830	Solar	1	0
Transmission Losses	19	Existing 20-minute Demand Response	0	0
Pumps	0	Mothballed	0	0
Load + Losses + Pumps	848	Total	579	578

All of the resources needed to meet the Stanislaus sub-area count towards the Tesla-Bellota sub-area LCR need.

3.3.4.5.3 Tesla-Bellota LCR Sub-area Hourly Profiles

Figure 3.3-41 illustrates the 2017 Category C (Multiple Contingency) post contingency flows on the limiting facility for the summer peak, winter peak and spring off-peak days for the Tesla-Bellota

Sub-area transmission capability without resources. Figure 3.3-42Figure 3.3-25 illustrates the 2017 hourly profile of the Category C (Multiple Contingency) post contingency flows on the limiting facility for Tesla-Bellota LCR Sub-area without resources.

Figure 3.3-41 Tesla-Bellota LCR Sub-area 2017 Limiting Post Contingency Peak Day Profiles

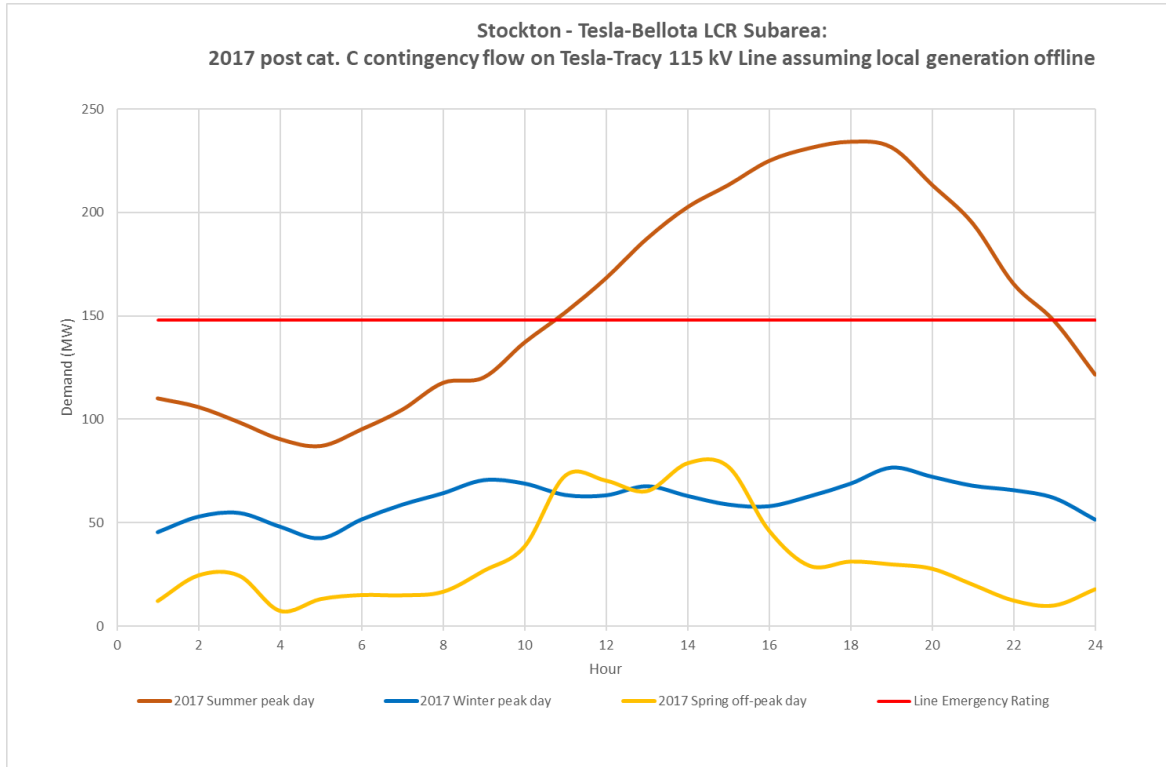
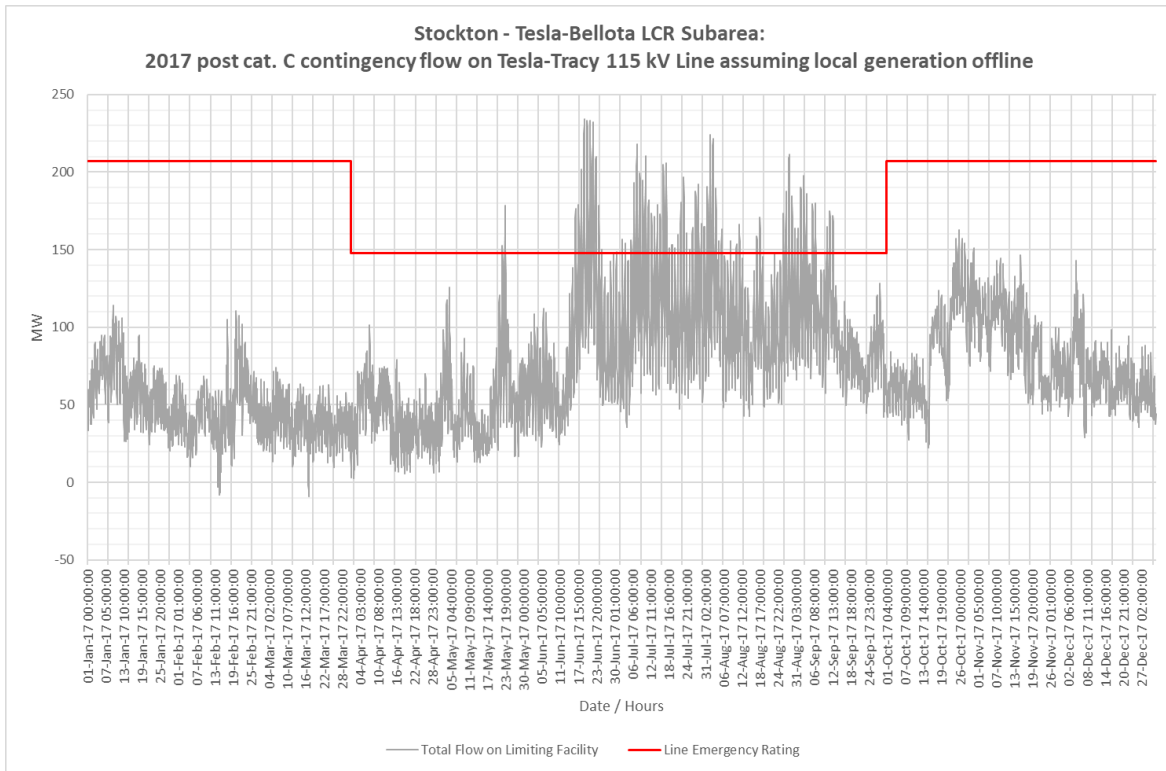

Figure 3.3-42 Tesla-Bellota LCR Sub-area 2017 Limiting Post Contingency Hourly Profiles



3.3.4.5.4 Tesla-Bellota LCR Sub-area Requirement

Table 3.3-29 identifies the sub-area requirements. The LCR requirement for Category B (Single Contingency) is 639 MW including a 60 MW NQC and 61 MW at peak deficiency and for Category C (Multiple Contingency) is 1117 MW including a 538 MW NQC and 539 MW at peak deficiency.

Table 3.3-29 Tesla-Bellota LCR Sub-area Requirements

Year	Limit	Category	Limiting Facility	Contingency	LCR (MW) (Deficiency)
2020	First limit	B	Tesla – Tracy 115 kV	Schulte - Lammers 115 kV & GWF Tracy #3 unit	639 (60 NQC/ 61 Peak)
2020	First limit	C	Schulte-Kasson-Manteca 115 kV	Schulte – Lammers 115 kV & Tesla – Tracy 115 kV	1117 (538 NQC/ 539 Peak)

3.3.4.5.5 Effectiveness factors:

All units within this sub-area are needed therefore no effectiveness factor is required.

For most helpful procurement information please read procedure 2210Z Effectiveness Factors under 7110 (T-138Z) posted at: <http://www.caiso.com/Documents/2210Z.pdf>

3.3.4.6 Stockton Overall

3.3.4.6.1 Stockton LCR Area Overall Requirement

The requirement for this area is driven by the sum of requirements for the Tesla-Bellota and Weber sub-areas. Table 3.3-30 identifies the area requirements. The LCR requirement for Category B (Single Contingency) is 687 MW including 84 MW of NQC deficiency or 85 MW of at peak deficiency and for Category C (Multiple Contingency) is 1240 MW with a 611 MW NQC deficiency or 612 MW at peak deficiency.

Table 3.3-30 Stockton LCR Sub-area Overall Requirements

Year	Limit	Category	Limiting Facility	Contingency	LCR (MW) (Deficiency)
2020		B	Stockton Overall		687 (84 NQC/ 85 Peak)
2020		C	Stockton Overall		1240 (611 NQC/ 612 Peak)

3.3.4.6.2 Changes compared to 2019 LCT study

The load forecast went up by 101 MW and the total LCR need has increased by 463 MW due to increase in load. The load has a much higher effectiveness factor than the most effective resource.

3.3.5 Greater Bay Area

3.3.5.1 Area Definition:

The transmission tie lines into the Greater Bay Area are:

- Lakeville-Sobrante 230 kV
- Ignacio-Sobrante 230 kV
- Parkway-Moraga 230 kV
- Bahia-Moraga 230 kV
- Lambie SW Sta-Vaca Dixon 230 kV
- Peabody-Contra Costa P.P. 230 kV
- Tesla-Kelso 230 kV
- Tesla-Delta Switching Yard 230 kV

- Tesla-Pittsburg #1 230 kV
- Tesla-Pittsburg #2 230 kV
- Tesla-Newark #1 230 kV
- Tesla-Newark #2 230 kV
- Tesla-Ravenswood 230 kV
- Tesla-Metcalf 500 kV
- Moss Landing-Metcalf 500 kV
- Moss Landing-Metcalf #1 230 kV
- Moss Landing-Metcalf #2 230 kV
- Oakdale TID-Newark #1 115 kV
- Oakdale TID-Newark #2 115 kV

The substations that delineate the Greater Bay Area are:

- Lakeville is out Sobrante is in
- Ignacio is out Sobrante is in
- Parkway is out Moraga is in
- Bahia is out Moraga is in
- Lambie SW Sta is in Vaca Dixon is out
- Peabody is out Contra Costa P.P. is in
- Tesla is out Kelso is in
- Tesla is out Delta Switching Yard is in
- Tesla is out Pittsburg is in
- Tesla is out Pittsburg is in
- Tesla is out Newark is in
- Tesla is out Newark is in
- Tesla is out Ravenswood is in
- Tesla is out Metcalf is in
- Moss Landing is out Metcalf is in
- Moss Landing is out Metcalf is in
- Moss Landing is out Metcalf is in
- Oakdale TID is out Newark is in

- Oakdale TID is out Newark is in

3.3.5.1.1 Greater Bay LCR Area Diagram

Figure 3.3-43 Greater Bay LCR Area

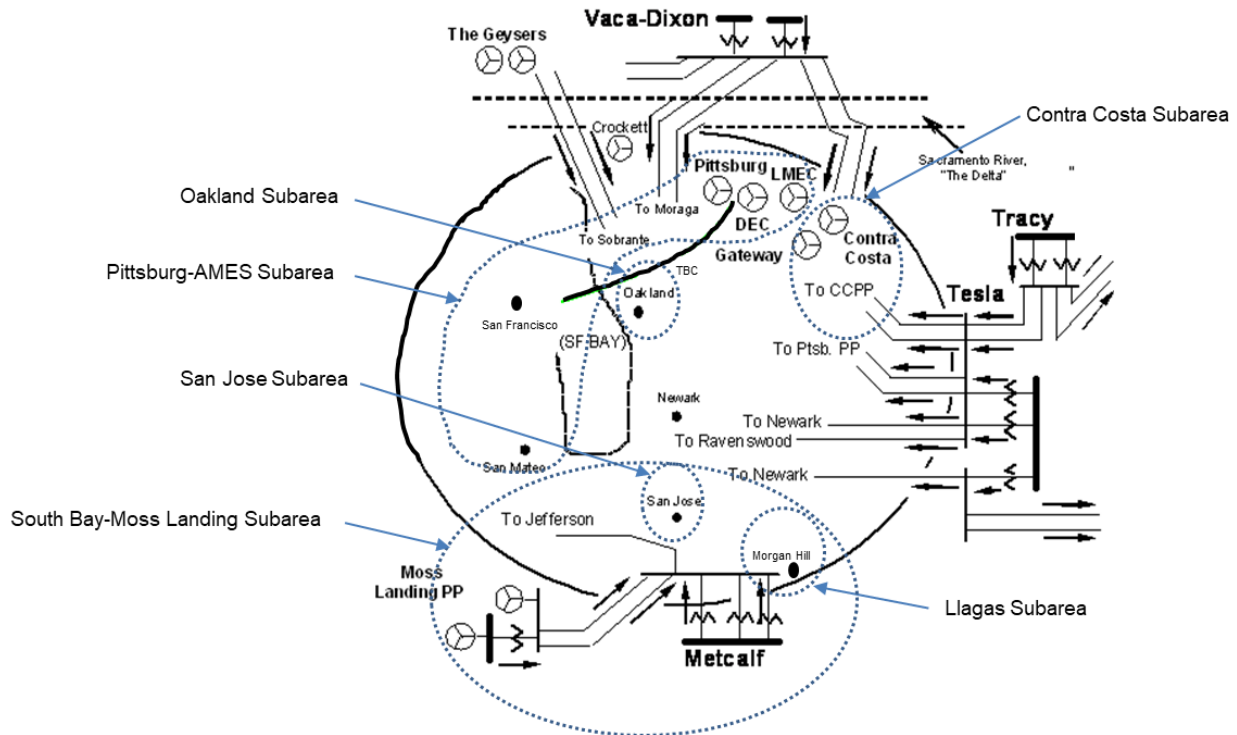

3.3.5.1.2 Greater Bay LCR Area Load and Resources

Table 3.3-31 provides the forecasted load and resources. The list of generators within the LCR area are provided in Attachment A.

In year 2020 the estimated time of local area peak is 17:50 PM.

At the local area peak time the estimated, behind the meter, solar output is 14.46%.

At the local area peak time the estimated, ISO metered, solar output is 44.00%.

If required, all technology type resources, including solar, are dispatched at NQC.

Table 3.3-31 Greater Bay Area LCR Area 2020 Forecast Load and Resources

Load (MW)		Generation (MW)	NQC	At Peak
Gross Load	10336	Market, Net Seller, Wind, Battery	6438	6438
AAEE	-118	MUNI	382	382
Behind the meter DG	-235	QF	235	235

Net Load	9983	Solar	12	12
Transmission Losses	241	Existing 20-minute Demand Response	0	0
Pumps	264	Mothballed	0	0
Load + Losses + Pumps	10488	Total	7067	7067

3.3.5.1.3 Approved transmission projects modeled

- Metcalf-Evergreen 115 kV Line Reconductoring
- Trimble-San Jose B 115 kV Line Limiting Facility Upgrade
- Trimble-San Jose B 115 kV Series Reactor
- Moss Landing-Panoche 230 kV Path Upgrade
- South of San Mateo Capacity Increase

3.3.5.2 Llagas Sub-area

Llagas is a Sub-area of the Greater Bay LCR Area.

3.3.5.2.1 Llagas LCR Sub-area Diagram

Figure 3.3-44 Llagas LCR Sub-area

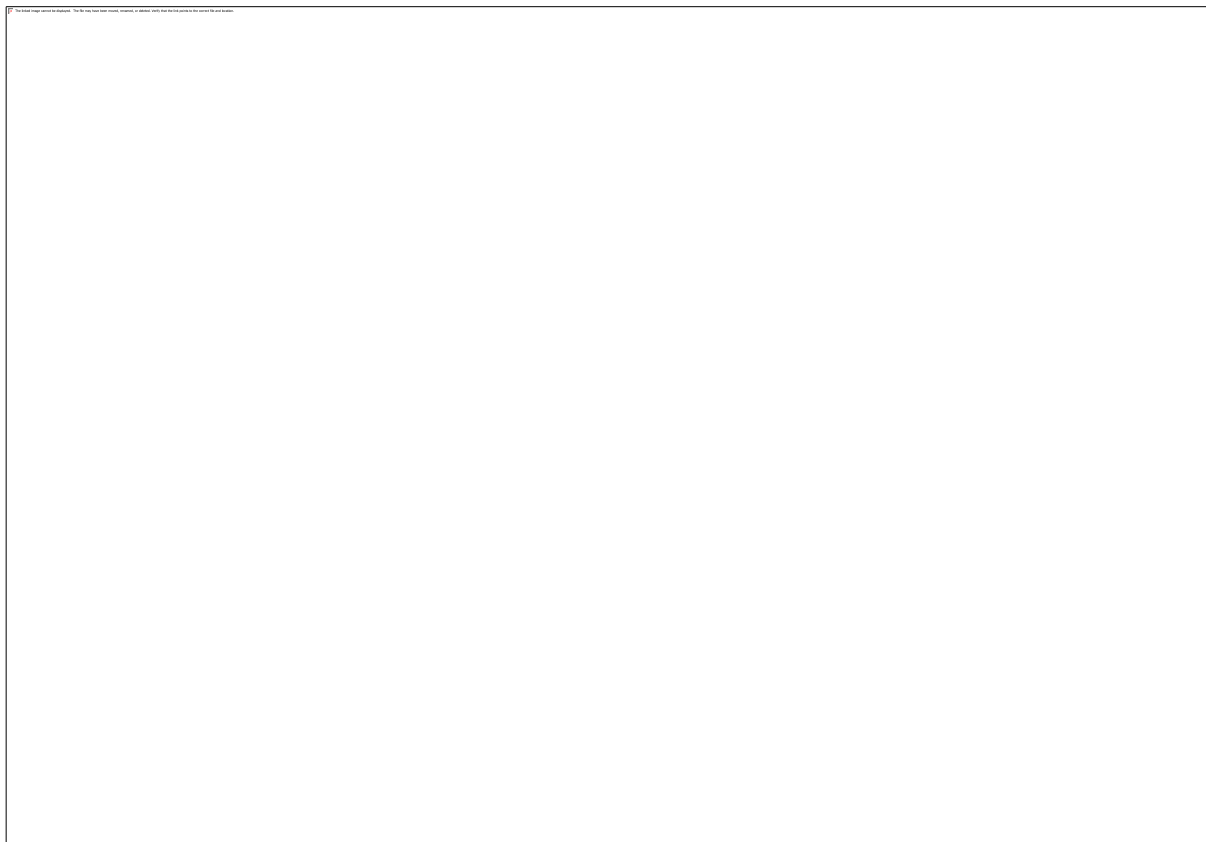

3.3.5.2.2 Llagas LCR Sub-area Load and Resources

Table 3.3-32 provides the forecasted load and resources. The list of generators within the LCR Sub-area are provided in Attachment A.

Table 3.3-32 Llagas LCR Sub-area 2020 Forecast Load and Resources

Load (MW)		Generation (MW)	NQC	At Peak
Gross Load	190	Market	246	246
AAEE	-2	MUNI	0	0
Behind the meter DG	-8	QF	0	0
Net Load	180	LTPP Preferred Resources	0	0
Transmission Losses	0	Existing 20-minute Demand Response	0	0
Pumps	0	Mothballed	0	0
Load + Losses + Pumps	180	Total	246	246

3.3.5.2.3 Llagas LCR Sub-area Hourly Profiles

Figure 3.3-45 illustrates the forecast 2020 profile for the summer peak, winter peak and spring off-peak days for the Llagas LCR Sub-area with the Category C (Multiple Contingency) transmission capability without resources. Figure 3.3-46 illustrates the forecast 2020 hourly profile for Llagas LCR Sub-area with the Category C (Multiple Contingency) transmission capability without resources.

Figure 3.3-45 Llagas LCR Sub-area 2020 Peak Day Forecast Profiles

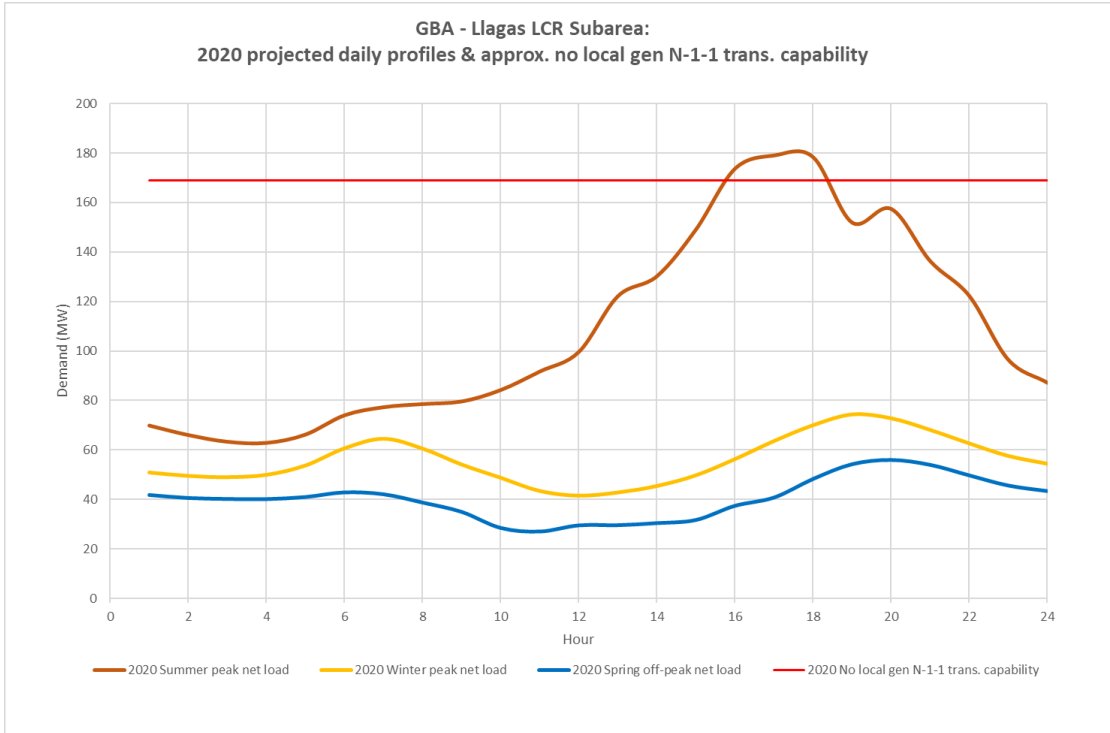
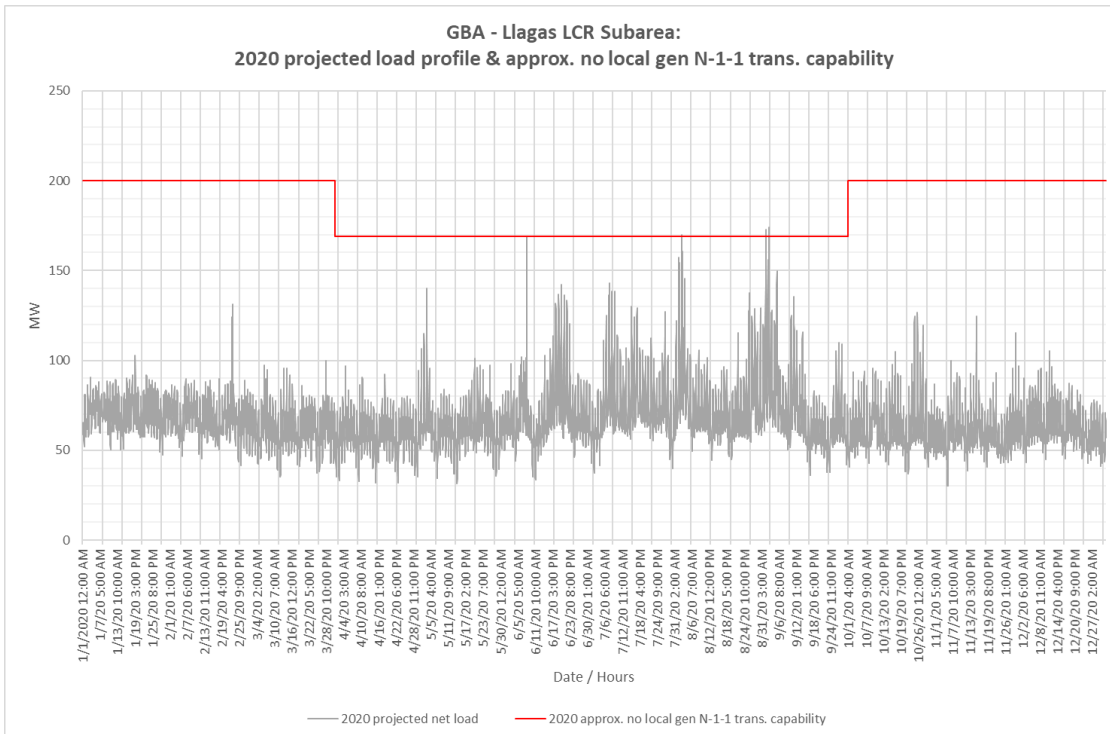

Figure 3.3-46 Llagas LCR Sub-area 2020 Forecast Hourly Profiles



3.3.5.2.4 Llagas LCR Sub-area Requirement

Table 3.3-33 identifies the sub-area requirements. The LCR requirement for Category B (Single Contingency) and Category C (Multiple Contingency) is the same 79 MW.

Table 3.3-33 Llagas LCR Sub-area Requirements

Year	Limit	Category	Limiting Facility	Contingency	LCR (MW) (Deficiency)
2020	First limit	B/C	Morgan Hill-Llagas 115 kV	Metcalf "D"-Morgan Hill 115 kV & one Gilroy peaker of-line	79

3.3.5.2.5 Effectiveness factors:

All units within this sub-area have the same effectiveness factor.

For most helpful procurement information please read procedure 2210Z Effectiveness Factors under 7110 (T-138Z) posted at: <http://www.caiso.com/Documents/2210Z.pdf>

3.3.5.3 San Jose Sub-area

San Jose is a Sub-area of the Greater Bay LCR Area.

3.3.5.3.1 San Jose LCR Sub-area Diagram

The San Jose LCR Sub-area is identified in Figure 3.3-43.

3.3.5.3.2 San Jose LCR Sub-area Load and Resources

Table 3.3-34 provides the forecast load and resources in San Jose LCR Sub-area in 2020. The list of generators within the LCR Sub-area are provided in Attachment A.

Table 3.3-34 San Jose LCR Sub-area 2020 Forecast Load and Resources

Load (MW)		Generation (MW)	NQC	At Peak
Gross Load	2465	Market, Net Seller, Battery	338	338
AAEE	-34	MUNI	202	202
Behind the meter DG	-46	QF	0	0
Net Load	2385	LTPP Preferred Resources	0	0
Transmission Losses	67	Existing 20-minute Demand Response	0	0
Pumps	0	Mothballed	0	0
Load + Losses + Pumps	2452	Total	540	540

3.3.5.3.3 San Jose LCR Sub-area Hourly Profiles

Figure 3.3-47 illustrates the forecast 2020 profile for the summer peak, winter peak and spring off-peak days for the San Jose LCR Sub-area with the Category C (Multiple Contingency)

transmission capability without resources. Figure 3.3-48 illustrates the forecast 2020 hourly profile for San Jose LCR Sub-area with the Category C (Multiple Contingency) transmission capability without resources.

Figure 3.3-47 San Jose LCR Sub-area 2020 Peak Day Forecast Profiles

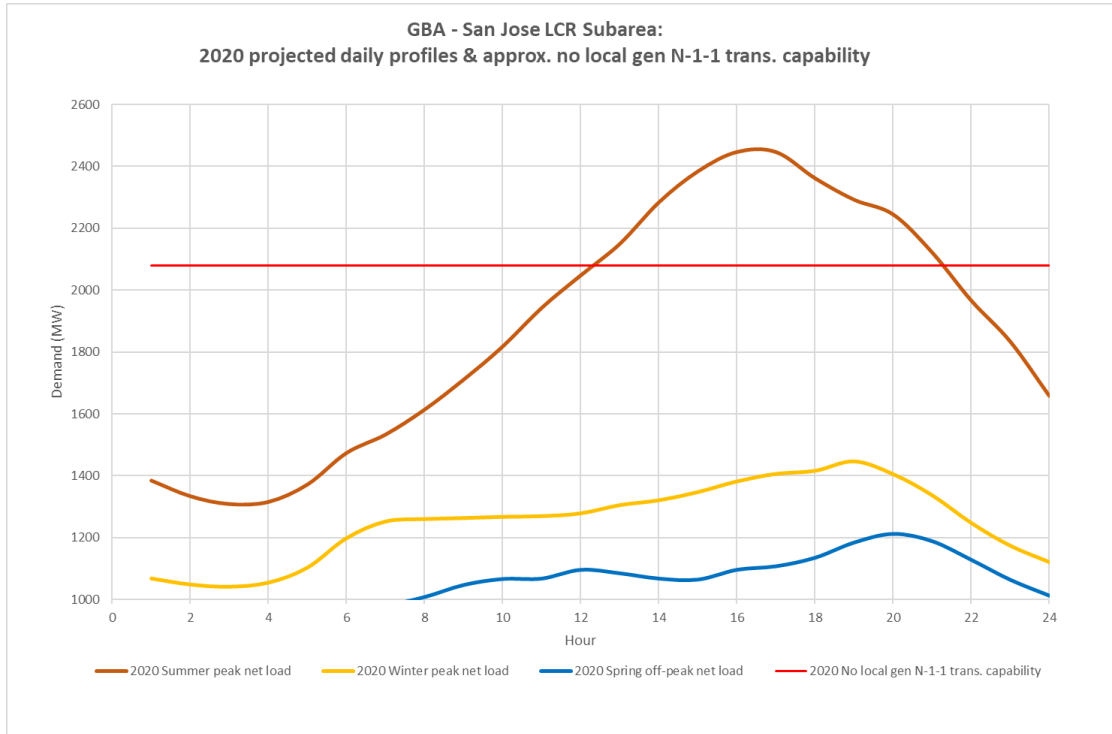
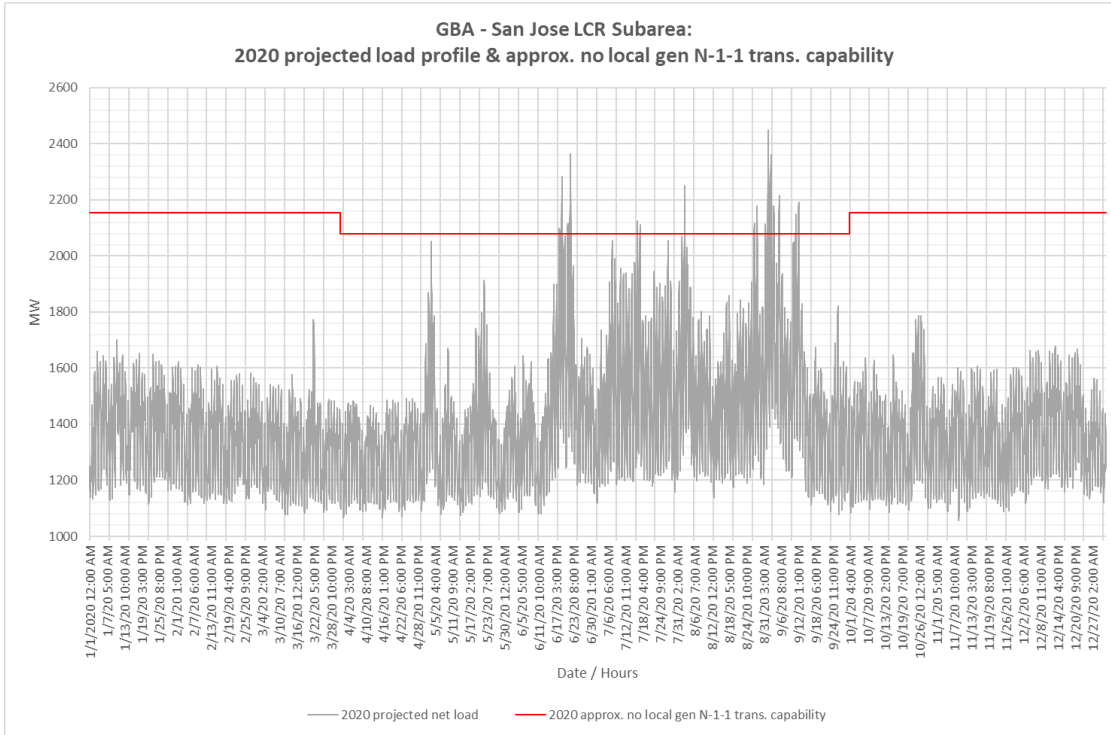

Figure 3.3-48 San Jose LCR Sub-area 2020 Forecast Hourly Profiles



3.3.5.3.4 San Jose LCR Sub-area Requirement

Table 3.3-35 identifies the sub-area LCR requirements. There was no LCR requirement for Category B (Single Contingency) and the LCR requirement for Category C (Multiple Contingency) is 305 MW.

Table 3.3-35 San Jose LCR Sub-area Requirements

Year	Limit	Category	Limiting Facility	Contingency	LCR (MW) (Deficiency)
2020	First limit	B	No requirement		
2020	First limit	C	El Patio-San Jose 'A' 115 kV	Stone-Evergreen-Metcalf 115 kV & Metcalf-Evergreen 115 kV	305

3.3.5.3.5 Effectiveness factors:

Effective factors for generators in the San Jose LCR Sub-area are in Attachment B table titled [San Jose](#).

For other helpful procurement information please read procedure 2210Z Effectiveness Factors under 7320 (T-165Z) posted at: <http://www.caiso.com/Documents/2210Z.pdf>

3.3.5.4 South Bay-Moss Landing Sub-area

South Bay-Moss Landing is a Sub-area of the Greater Bay LCR Area.

3.3.5.4.1 South Bay-Moss Landing LCR Sub-area Diagram

The South Bay-Moss Landing LCR Sub-area is identified in Figure 3.3-44.

3.3.5.4.2 South Bay-Moss Landing LCR Sub-area Load and Resources

Table 3.3-36 provides the forecast load and resources in South Bay-Moss Landing LCR Sub-area in 2020. The list of generators within the LCR Sub-area are provided in Attachment A.

Table 3.3-36 South Bay-Moss Landing LCR Sub-area 2020 Forecast Load and Resources

Load (MW)		Generation (MW)	NQC	At Peak
Gross Load	4089	Market, Net Seller, Battery	2175	2175
AAEE	-52	MUNI	202	202
Behind the meter DG	-93	QF	0	0
Net Load	3944	LTPP Preferred Resources	0	0
Transmission Losses	108	Existing 20-minute Demand Response	0	0
Pumps	0	Mothballed	0	0
Load + Losses + Pumps	4052	Total	2377	2377

3.3.5.4.3 South Bay-Moss Landing LCR Sub-area Hourly Profiles

Figure 3.3-49 illustrates the forecast 2020 profile for the summer peak, winter peak and spring off-peak days for the South Bay-Moss Landing LCR Sub-area with the Category C (Multiple Contingency) transmission capability without resources. Figure 3.3-50 illustrates the forecast 2020 hourly profile for South Bay-Moss Landing LCR Sub-area with the Category C (Multiple Contingency) transmission capability without resources.

Figure 3.3-49 South Bay-Moss Landing LCR Sub-area 2020 Peak Day Forecast Profiles

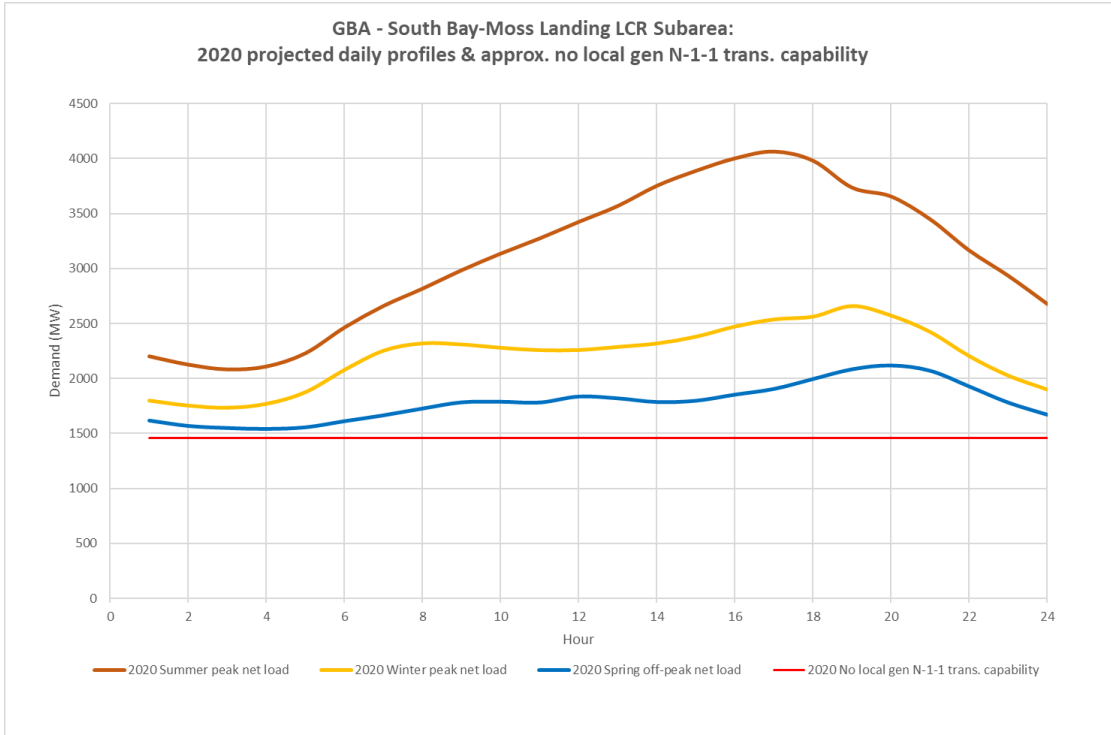
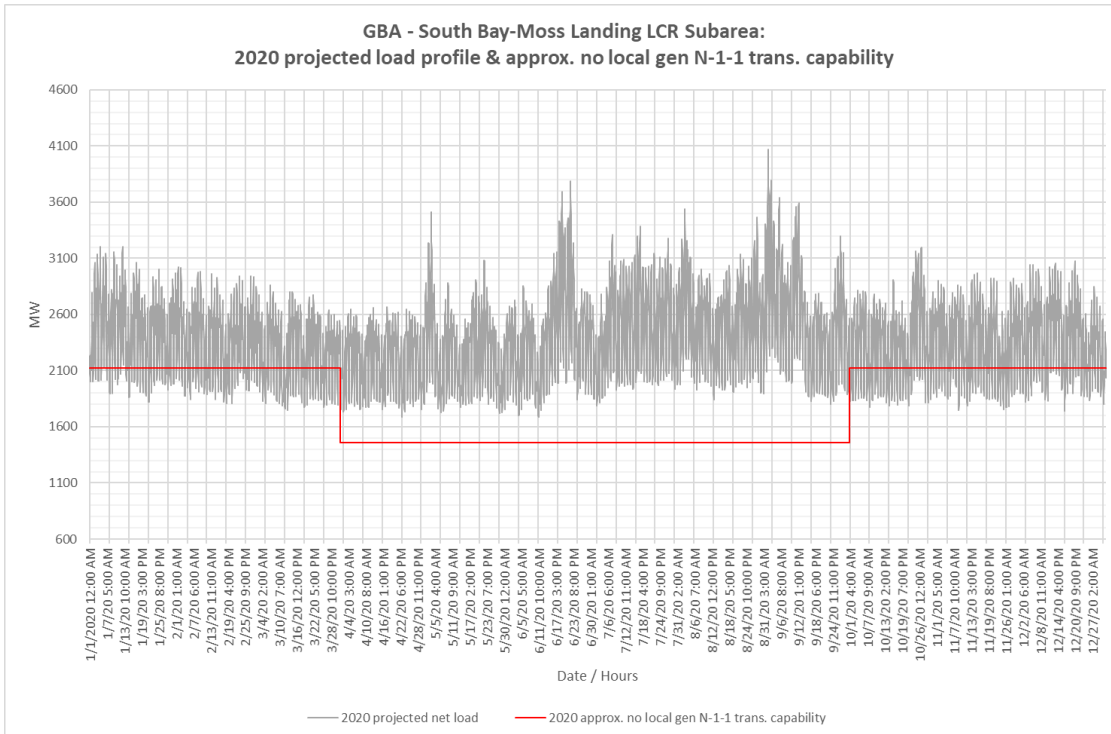

Figure 3.3-50 South Bay-Moss Landing LCR Sub-area 2020 Forecast Hourly Profiles



3.3.5.4.4 South Bay-Moss Landing LCR Sub- Requirement

Table 3.3-37 identifies the sub-area LCR requirements. There LCR requirement for Category B (Single Contingency) is non-binding and the LCR Requirement for a Category C (Multiple Contingency) is 1781 MW.

Table 3.3-37 South Bay-Moss Landing LCR Sub-area Requirements

Year	Limit	Category	Limiting Facility	Contingency	LCR (MW) (Deficiency)
2020	First Limit	B	None-binding	None-binding	
2020	First Limit	C	Moss Landing-Las Aguilas 230 kV	Tesla-Metcalf 500 kV and Moss Landing-Los Banos 500 kV	1781

3.3.5.4.5 Effectiveness factors:

Effective factors for generators in the South Bay-Moss Landing LCR Sub-area are in Attachment B table titled [South Bay-Moss Landing](#).

For other helpful procurement information please read procedure 2210Z Effectiveness Factors under 7320 (T-165Z) posted at: <http://www.caiso.com/Documents/2210Z.pdf>

3.3.5.5 Oakland Sub-area

Oakland is a Sub-area of the Greater Bay LCR Area.

3.3.5.5.1 Oakland LCR Sub-area Diagram

Figure 3.3-51 Oakland LCR Sub-area

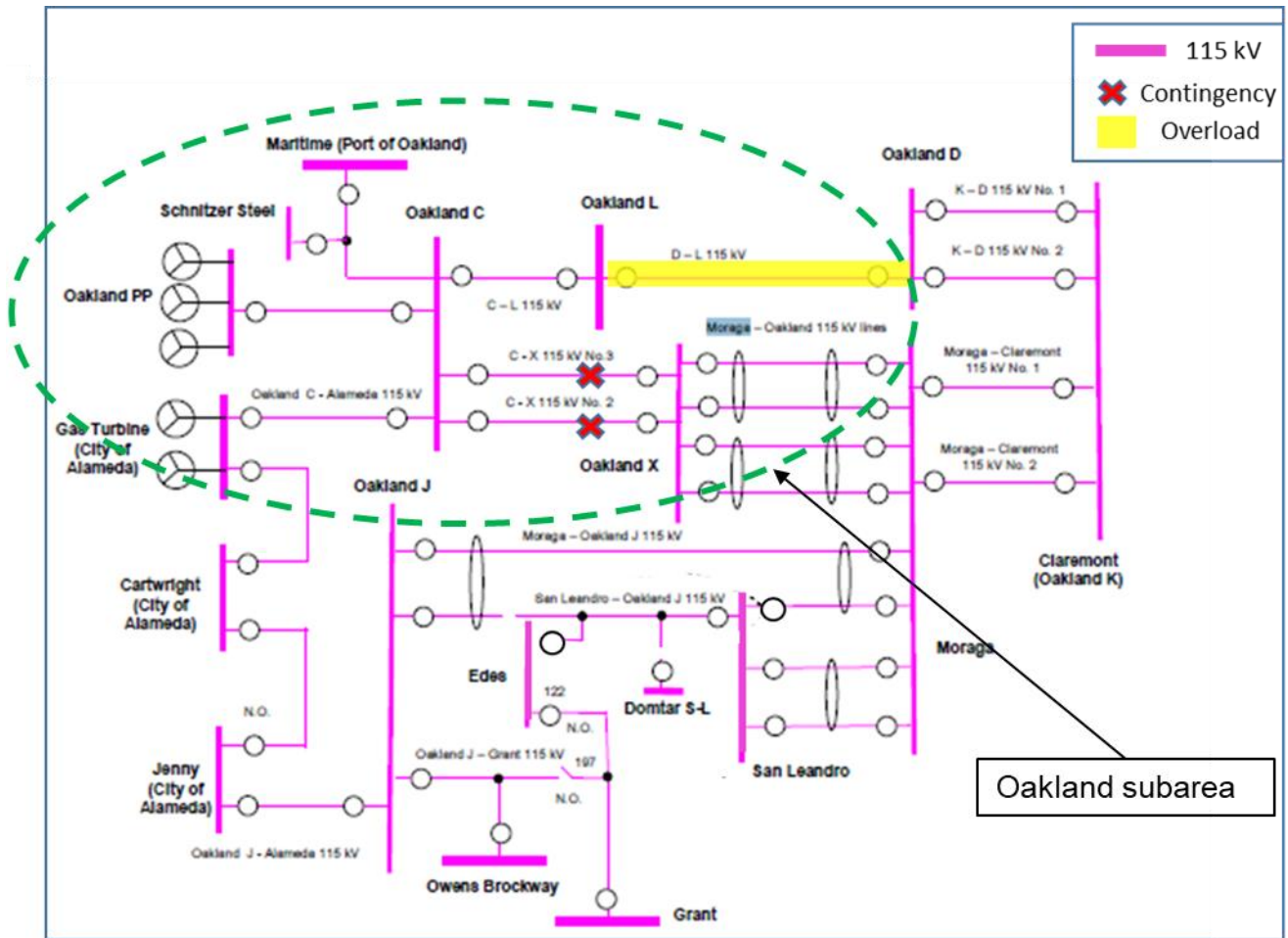

3.3.5.5.2 Oakland LCR Sub-area Load and Resources

Table 3.3-38 provides the forecast load and resources in Oakland LCR Sub-area in 2020. The list of generators within the LCR Sub-area are provided in Attachment A.

Table 3.3-38 Oakland LCR Sub-area 2020 Forecast Load and Resources

Load (MW)		Generation (MW)	NQC	At Peak
Gross Load	196	Market	165	165
AAEE	-3	MUNI	48	48
Behind the meter DG	-6	QF	0	0
Net Load	187	LTPP Preferred Resources	0	0
Transmission Losses	0	Existing 20-minute Demand Response	0	0
Pumps	0	Mothballed	0	0
Load + Losses + Pumps	187	Total	213	213

3.3.5.5.3 Oakland LCR Sub-area Hourly Profiles

Figure 3.3-52 illustrates the forecast 2020 profile for the summer peak, winter peak and spring off-peak days for the Oakland LCR Sub-area with the Category C (Multiple Contingency) transmission capability without resources. Figure 3.3-53 illustrates the forecast 2020 hourly profile for Oakland LCR Sub-area with the Category C (Multiple Contingency) transmission capability without resources.

Figure 3.3-52 Oakland LCR Sub-area 2020 Peak Day Forecast Profiles

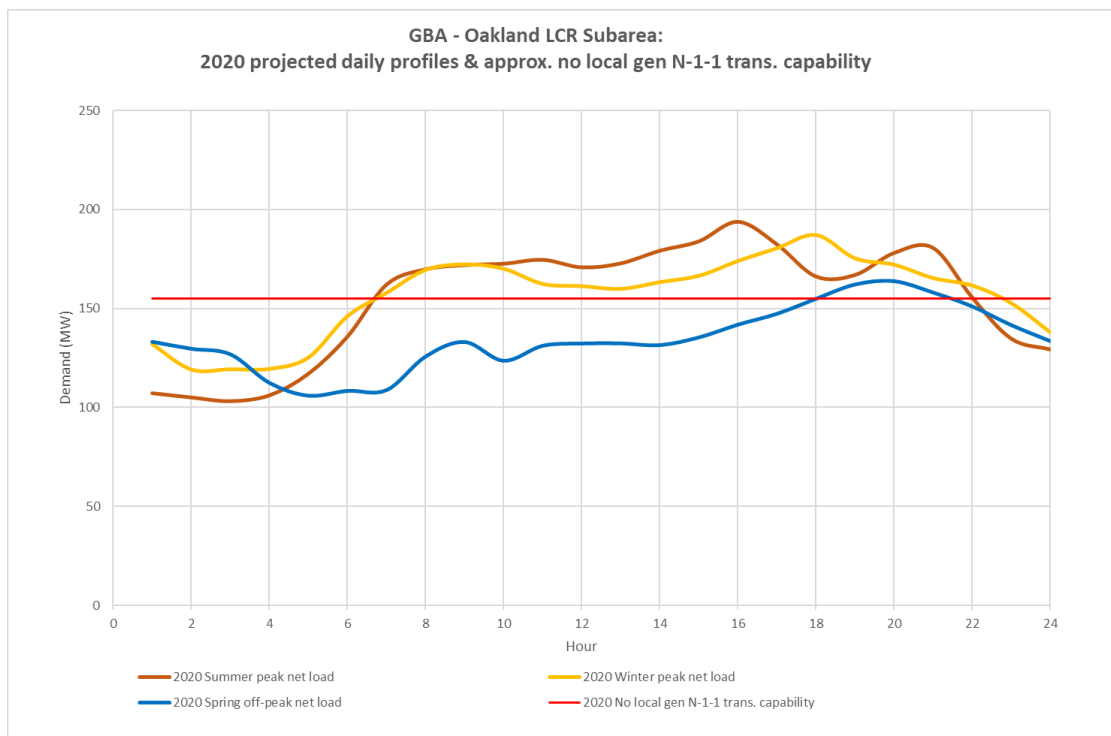
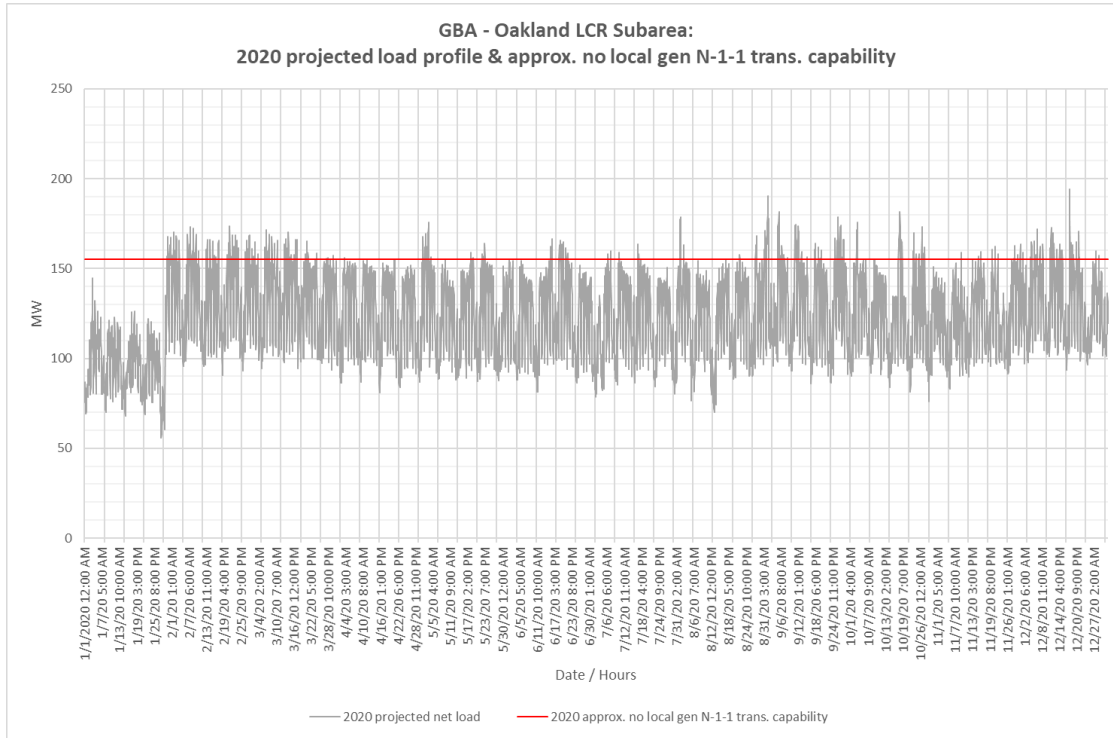

Figure 3.3-53 Oakland LCR Sub-area 2020 Forecast Hourly Profiles



3.3.5.5.4 Oakland LCR Sub-area Requirement

Table 3.3-39 identifies the sub-area requirements. There is no LCR requirement for Category B (Single Contingency) and the LCR Requirement for a Category C (Multiple Contingency) is 32 MW.

Table 3.3-39 Oakland LCR Sub-area Requirements

Year	Limit	Category	Limiting Facility	Contingency	LCR (MW) (Deficiency)
2020	First limit	B	None	None	0
2020	First limit	C	Oakland D-L 115 kV cable	Oakland C-X #2 & #3 115 kV	32

3.3.5.5.5 Effectiveness factors:

All units within the Oakland Sub-area have the same effectiveness factor.

For most helpful procurement information please read procedure 2210Z Effectiveness Factors under 7110 (T-138Z) posted at: <http://www.caiso.com/Documents/2210Z.pdf>

3.3.5.6 Ames-Pittsburg-Oakland Sub-areas Combined

Ames-Pittsburg-Oakland is a Sub-area of the Greater Bay LCR Area.

3.3.5.6.1 Ames-Pittsburg-Oakland LCR Sub-area Diagram

Figure 3.3-54 Ames-Pittsburg-Oakland LCR Sub-area

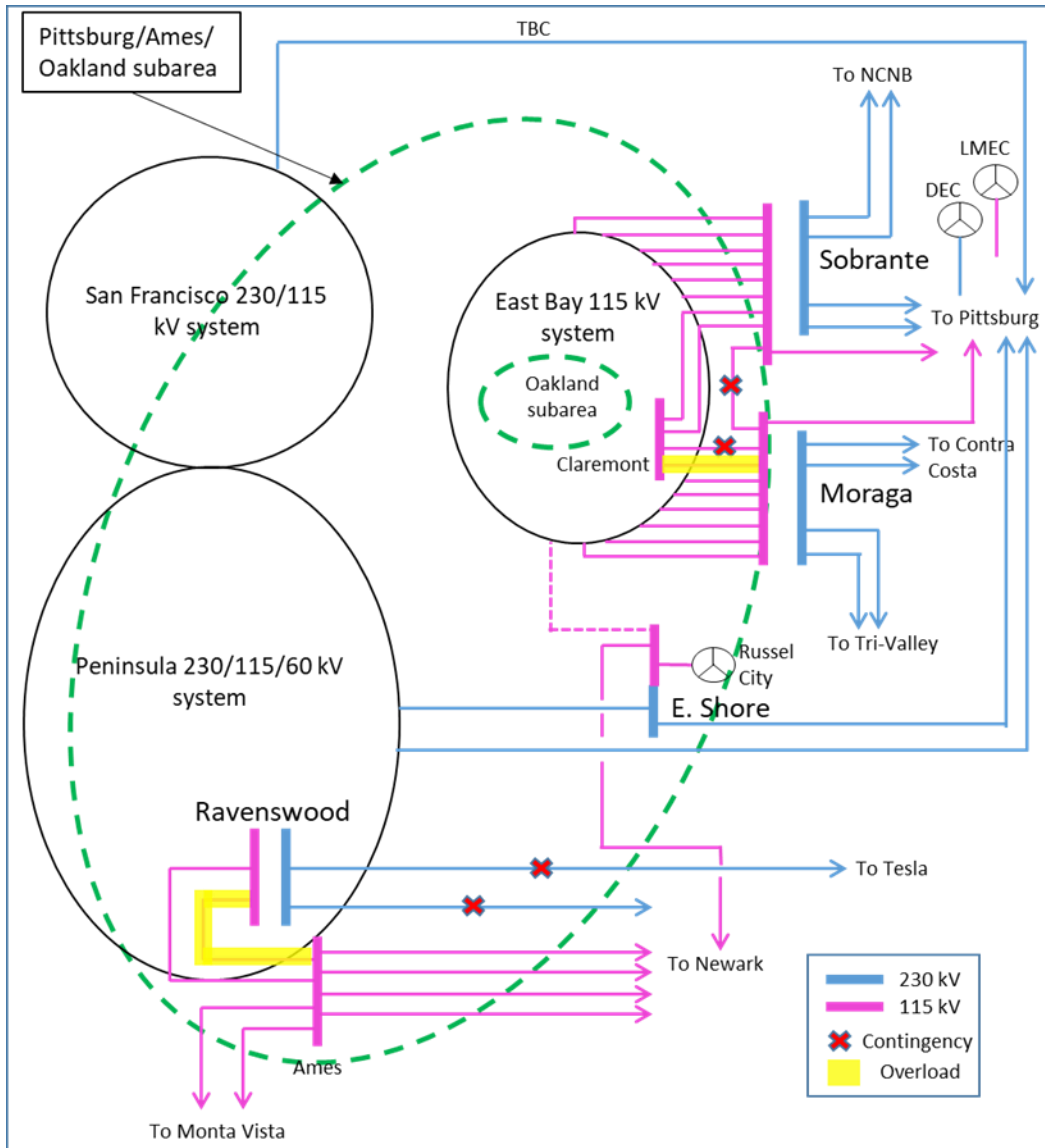

3.3.5.6.2 Ames-Pittsburg-Oakland LCR Sub-area Load and Resources

Table 3.3-40 provides the forecast load and resources in Ames-Pittsburg-Oakland LCR Sub-area in 2020. The list of generators within the LCR Sub-area are provided in Attachment A.

Table 3.3-40 Ames-Pittsburg-Oakland LCR Sub-area 2020 Forecast Load and Resources

Load (MW)	Generation (MW)	NQC	At Peak
The Ames-Pittsburg-Oakland Sub-area does not has a defined load pocket with the limits based upon power flow through the area.	Market, Net Seller	2182	2182
	MUNI	48	48
	QF	232	232
	Solar	8	8
	Existing 20-minute Demand Response	0	0
	Mothballed	0	0
	Total	2470	2470

3.3.5.6.3 Ames-Pittsburg-Oakland LCR Sub-area Hourly Profiles

The Ames-Pittsburg-Oakland Sub-area does not has a defined load pocket with the limits based upon power flow through the area. There are two limiting paths within the Ames-Pittsburg-Oakland Sub-area, Moraga-Claremont #2 115 kV line and Ames-Ravenswood #1 115 kV line. Figure 3.3-55 illustrates the 2017 Category C (Multiple Contingency) post contingency flows on the limiting facility (Moraga-Claremont #2 115 kV line) for the summer peak, winter peak and spring off-peak days for the Ames-Pittsburg-Oakland Sub-area transmission capability without resources. Figure 3.3-56 illustrates the 2017 hourly profile of the Category C (Multiple Contingency) post contingency flows on the limiting facility (Moraga-Claremont #2 115 kV line) for Ames-Pittsburg-Oakland LCR Sub-area without resources.

Figure 3.3-57 illustrates the 2017 Category C (Multiple Contingency) post contingency flows on the limiting facility (Ames-Ravenswood #1 115 kV line) for the summer peak, winter peak and spring off-peak days for the Ames-Pittsburg-Oakland Sub-area transmission capability without resources. Figure 3.3-58 illustrates the 2017 hourly profile of the Category C (Multiple Contingency) post contingency flows on the limiting facility (Ames-Ravenswood #1 115 kV line) for Ames-Pittsburg-Oakland LCR Sub-area without resources.

Figure 3.3-55 Ames-Pittsburg-Oakland LCR Sub-area 2017 Limiting Post Contingency Peak Day Profiles (Moraga-Claremont #2 115 kV line)

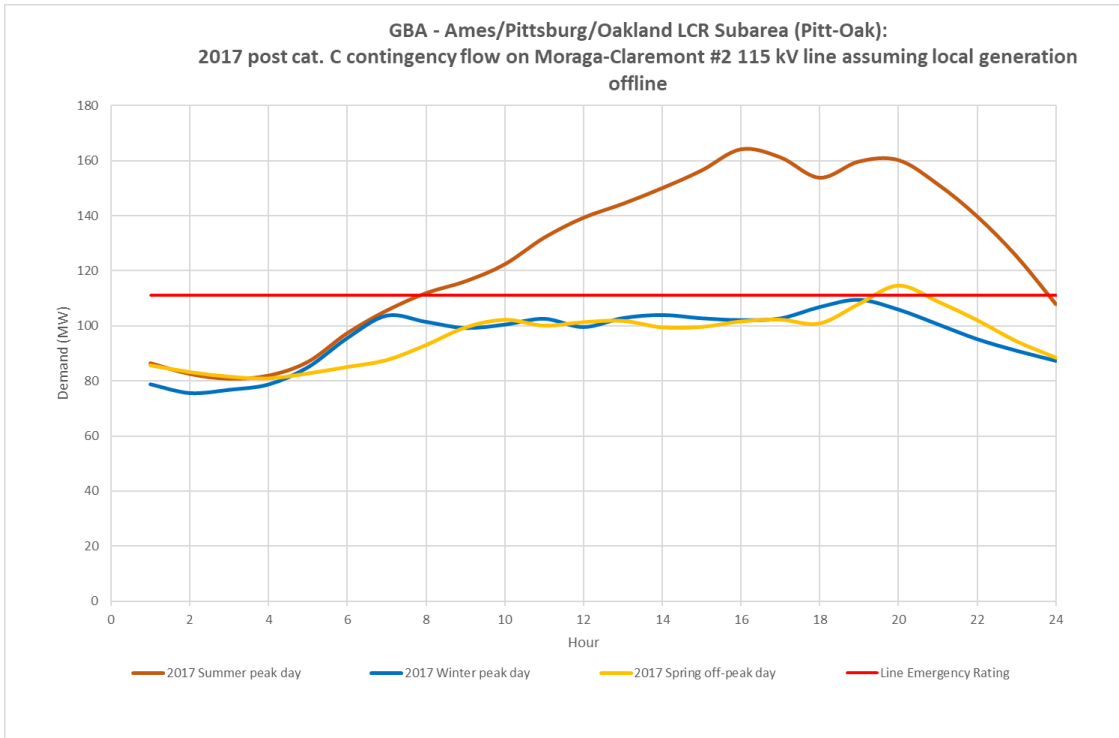

Figure 3.3-56 Ames-Pittsburg-Oakland LCR Sub-area 2017 Limiting Post Contingency Hourly Profiles (Moraga-Claremont #2 115 kV line)

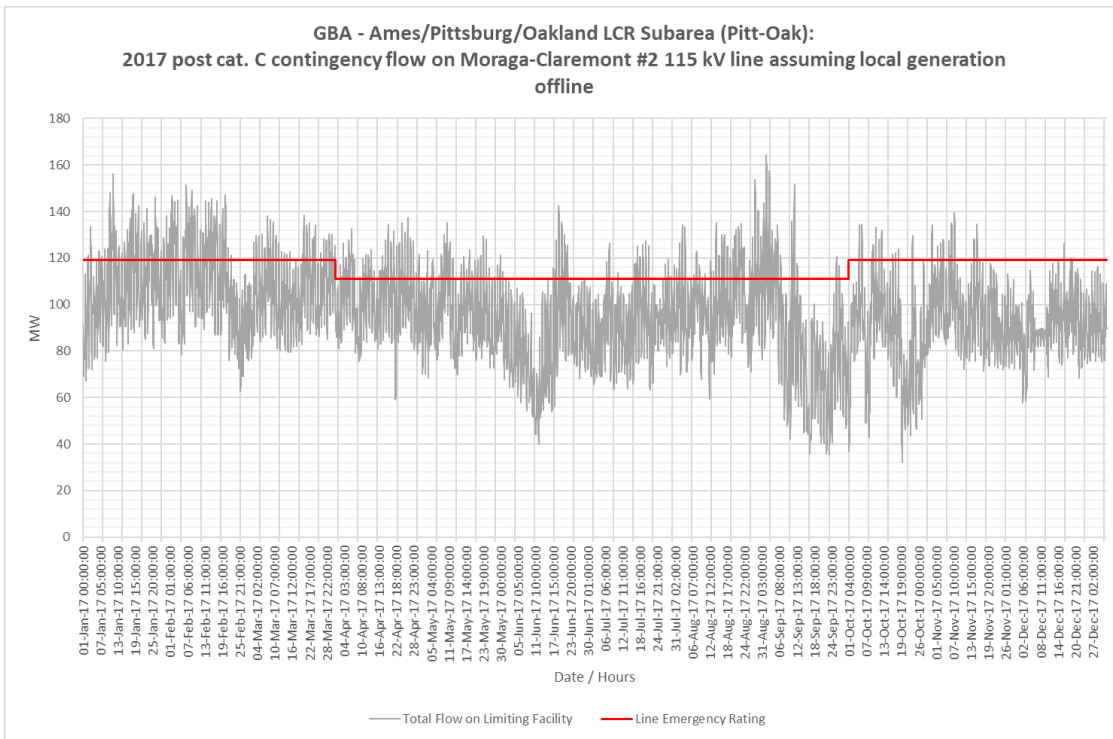

Figure 3.3-57 Ames-Pittsburg-Oakland LCR Sub-area 2017 Limiting Post Contingency Peak Day Profiles (Ames-Ravenswood #1 115 kV line)

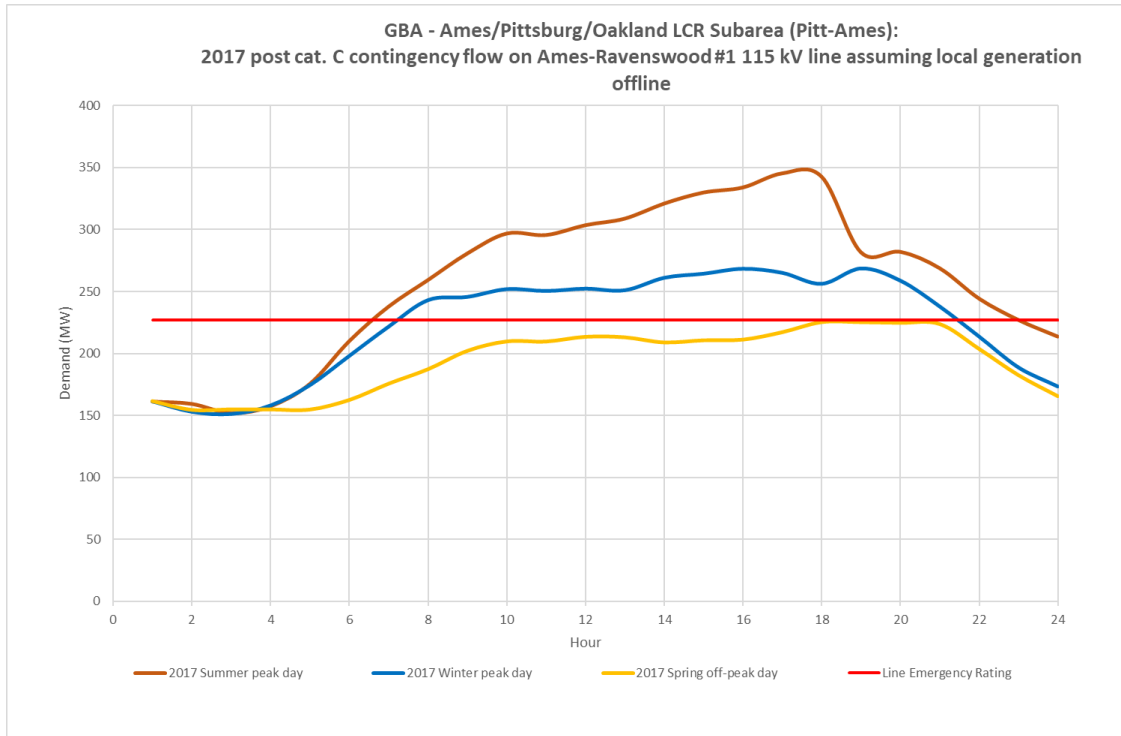
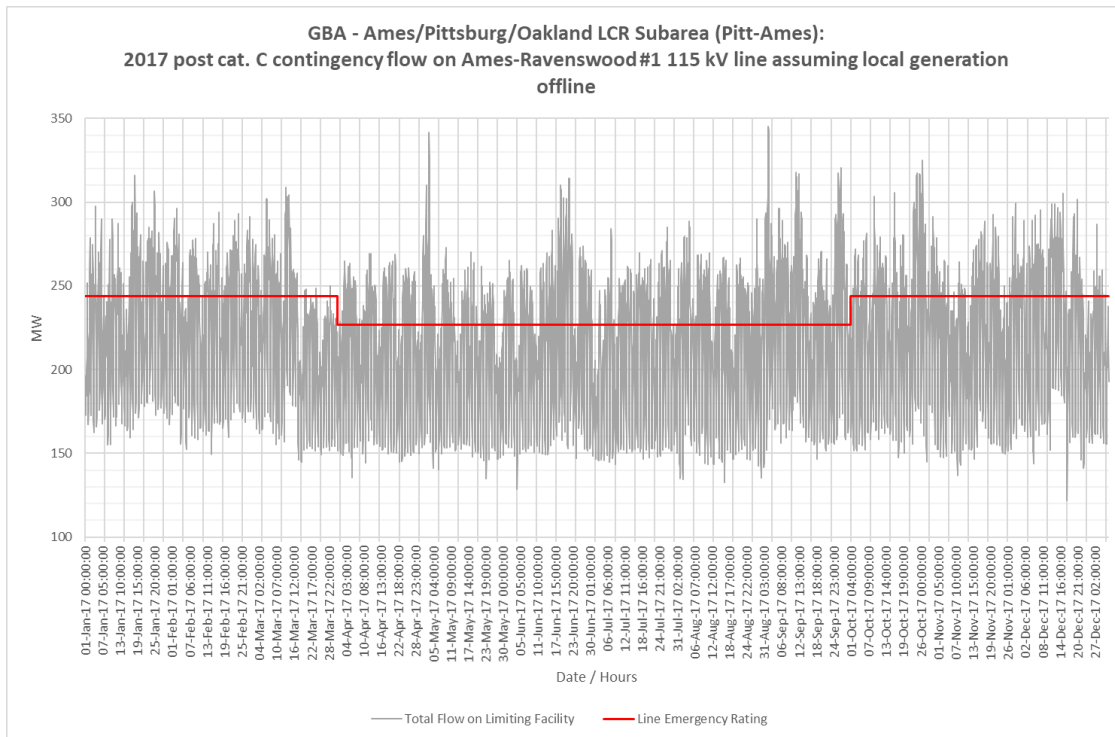

Figure 3.3-58 Ames-Pittsburg-Oakland LCR Sub-area 2017 Limiting Post Contingency Hourly Profiles (Ames-Ravenswood #1 115 kV line)



3.3.5.6.4 Ames-Pittsburg-Oakland LCR Sub-area Requirement

Table 3.3-41 identifies the sub-area LCR requirements. There LCR requirement for Category B (Single Contingency) is non-binding and the LCR Requirement for a Category C (Multiple Contingency) is 1614 MW.

Table 3.3-41 Ames-Pittsburg-Oakland LCR Sub-area Requirements

Year	Limit	Category	Limiting Facility	Contingency	LCR (MW) (Deficiency)
2020	First limit	B	None-binding	None-binding	
2020	First limit	C	Ames-Ravenswood #1 115 kV line	Newark-Ravenswood 230 kV & Tesla-Ravenswood 230 kV	1614
			Moraga-Claremont #2 115 kV line	Moraga-Sobrante 115 kV & Moraga-Claremont #1 115 kV	

3.3.5.6.5 Effectiveness factors:

Effective factors for generators in the Ames-Pittsburg-Oakland LCR Sub-area are in Attachment B table titled [Ames/Pittsburg/Oakland](#).

For other helpful procurement information please read procedure 2210Z Effectiveness Factors under 7320 (T-165Z) posted at: <http://www.caiso.com/Documents/2210Z.pdf>

3.3.5.7 Contra Costa Sub-area

Contra Costa is a Sub-area of the Greater Bay LCR Area.

3.3.5.7.1 Contra Costa LCR Sub-area Diagram

Figure 3.3-59 Contra Costa LCR Sub-area

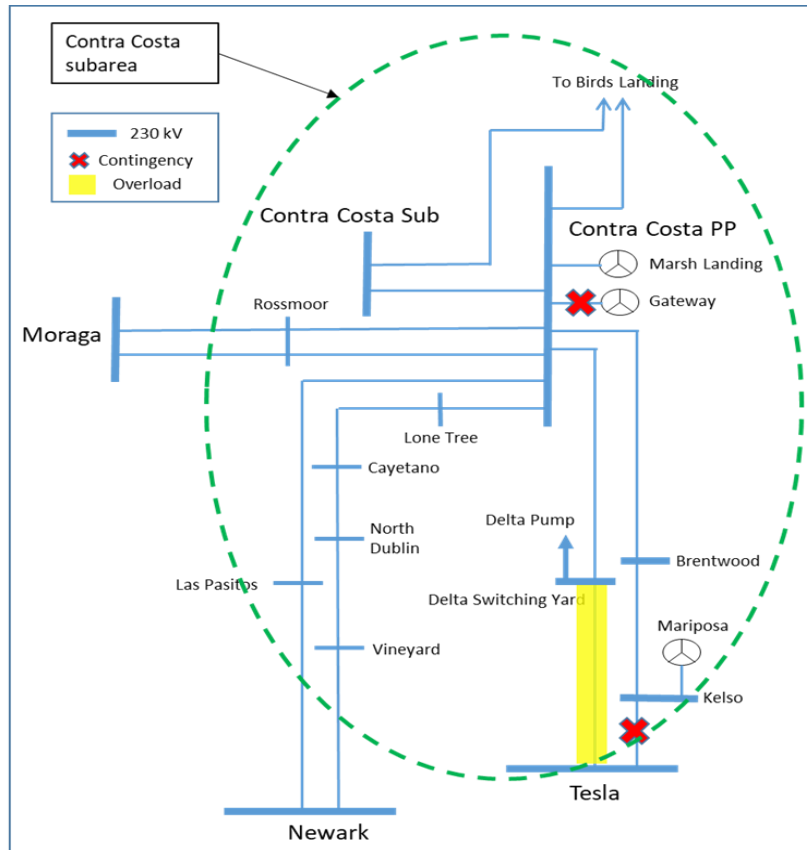

3.3.5.7.2 Contra Costa LCR Sub-area Load and Resources

Table 3.3-42 provides the forecast load and resources in Contra Costa LCR Sub-area in 2020. The list of generators within the LCR Sub-area are provided in Attachment A.

Table 3.3-42 Contra Costa LCR Sub-area 2020 Forecast Load and Resources

Load (MW)	Generation (MW)	NQC	At Peak
The Contra Costa Sub-area does not has a defined load pocket with the limits based upon power flow through the area.	Market, Net Seller, Wind	2055	2055
	MUNI	127	127
	QF	0	0
	Solar	0	0
	Existing 20-minute Demand Response	0	0
	Mothballed	0	0
	Total		2182

3.3.5.7.3 Contra Costa LCR Sub-area Hourly Profiles

The Contra Costa Sub-area does not have a defined load pocket with the limits based upon power flow through the area.

Figure 3.3-60 illustrates the 2017 Category C (Multiple Contingency) post contingency flows on the limiting facility for the summer peak, winter peak and spring off-peak days for the Contra Costa Sub-area transmission capability without resources. Figure 3.3-61 illustrates the 2017 hourly profile of the Category C (Multiple Contingency) post contingency flows on the limiting facility for Contra Costa LCR Sub-area without resources.

Figure 3.3-60 Contra Costa LCR Sub-area 2017 Limiting Post Contingency Peak Day Profiles

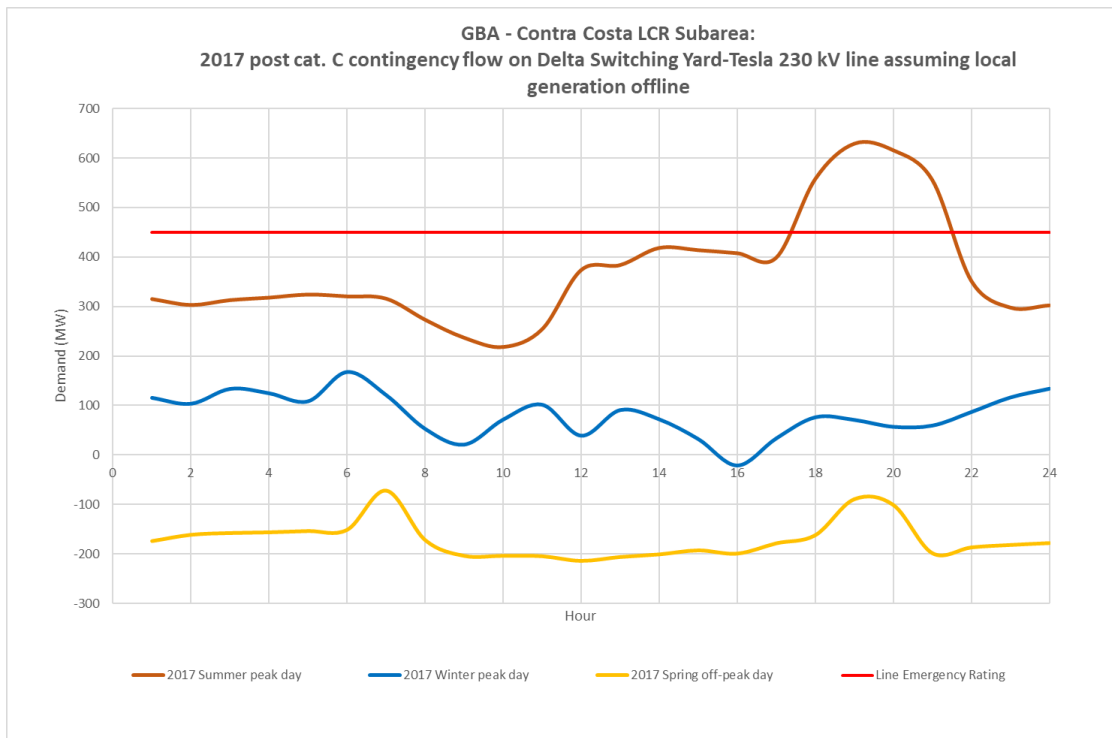
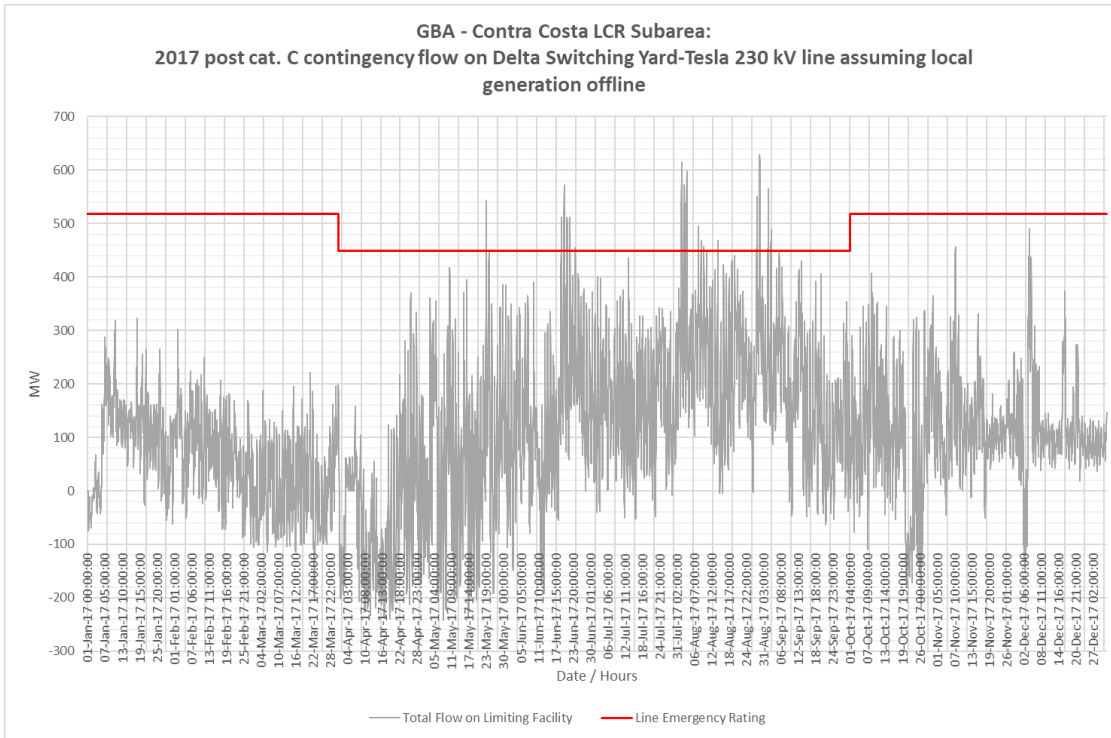

Figure 3.3-61 Contra Costa LCR Sub-area 2017 Limiting Post Contingency Hourly Profiles



3.3.5.7.4 Contra Costa LCR Sub-area Requirement

Table 3.3-43 identifies the sub-area LCR requirements. The LCR requirement for Category B (Single Contingency) and Category C (Multiple Contingency) is the same 1155 MW.

Table 3.3-43 Contra Costa LCR Sub-area Requirements

Year	Limit	Category	Limiting Facility	Contingency	LCR (MW) (Deficiency)
2020	First limit	B/C	Delta Switching Yard-Tesla 230 kV	Kelso-Tesla 230 kV line and Gateway unit	1155

3.3.5.7.5 Effectiveness factors:

For other helpful procurement information please read procedure 2210Z Effectiveness Factors under 7230 (T-165Z) posted at: <http://www.caiso.com/Documents/2210Z.pdf>

3.3.5.8 Bay Area overall

3.3.5.8.1 Greater Bay LCR Area Overall Requirement

Table 3.3-44 identifies the area LCR requirements. The LCR requirement for Category B (Single Contingency) is 3970 MW and for Category C (Multiple Contingency) is 4550 MW.

Table 3.3-44 Bay Area LCR Overall area Requirements

Year	Limit	Category	Limiting Facility	Contingency	LCR (MW) (Deficiency)
2020	First limit	B	Reactive margin	Tesla-Metcalf 500 kV line & DEC unit	3970
2020	First Limit	C	Aggregate of Sub-area requirements.		4550

3.3.5.8.2 Changes compared to 2019 requirements

Compared to 2019 load forecast went up by 258 MW and total LCR need went up by 89 MW mainly due to load increase.

3.3.6 Greater Fresno Area

3.3.6.1 Area Definition:

The transmission facilities coming into the Greater Fresno area are:

- Gates-Mustang #1 230 kV
- Gates-Mustang #2 230 kV
- Gates #5 230/70 kV Transformer Bank
- Mercy Spring 230 /70 Bank # 1
- Los Banos #3 230/70 Transformer Bank
- Los Banos #4 230/70 Transformer Bank
- Warnerville-Wilson 230kV
- Melones-North Merced 230 kV line
- Panoche-Tranquility #1 230 kV
- Panoche-Tranquility #2 230 kV
- Panoche #1 230/115 kV Transformer Bank
- Panoche #2 230/115 kV Transformer Bank
- Corcoran-Smyrna 115kV
- Coalinga #1-San Miguel 70 kV

The substations that delineate the Greater Fresno area are:

- Gates is out Mustang is in
- Gates is out Mustang is in

- Gates 230 is out Gates 70 is in
- Mercy Springs 230 is out Mercy Springs 70 is in
- Los Banos 230 is out Los Banos 70 is in
- Los Banos 230 is out Los Banos 70 is in
- Warnerville is out Wilson is in
- Melones is out North Merced is in
- Panoche is out Tranquility #1 is in
- Panoche is out Tranquility #2 is in
- Panoche 230 is out Panoche 115 is in
- Panoche 230 is out Panoche 115 is in
- Corcoran is in Smyrna is out
- Coalinga is in San Miguel is out

3.3.6.1.2 Fresno LCR Area Diagram

Figure 3.3-62 Fresno LCR Area

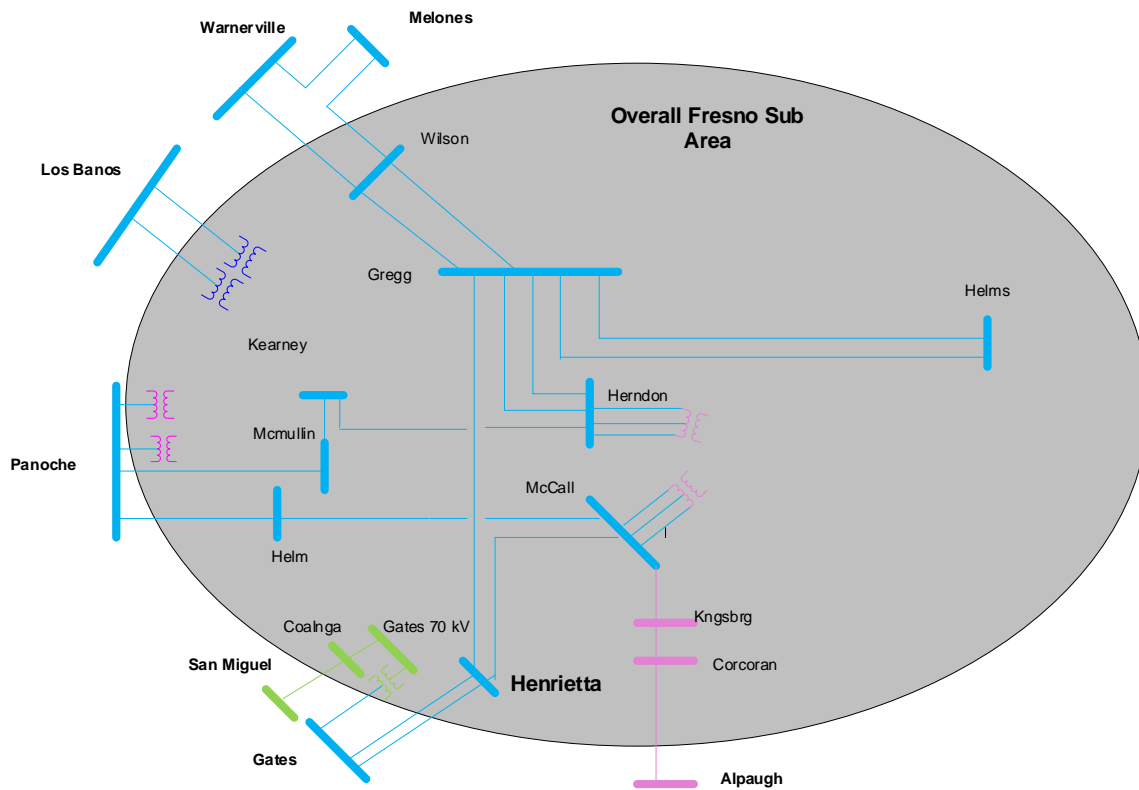

3.3.6.1.3 Fresno LCR Area Load and Resources

In year 2020 the estimated time of local area peak is 18:40 PM.

At the local area peak time the estimated, behind the meter, solar output is 0.00%.

At the local area peak time the estimated, ISO metered, solar output is 12.00%.

If required, all non-solar technology type resources are dispatched at NQC.

Table 3.3-45 provides the forecast load and resources in Fresno LCR Area in 2020. The list of generators within the LCR Sub-area are provided in Attachment A.

In year 2020 the estimated time of local area peak is 18:40 PM.

At the local area peak time the estimated, behind the meter, solar output is 0.00%.

At the local area peak time the estimated, ISO metered, solar output is 12.00%.

If required, all non-solar technology type resources are dispatched at NQC.

Table 3.3-45 Fresno LCR Area 2020 Forecast Load and Resources

Load (MW)		Generation (MW)	NQC	At Peak
Gross Load	3220	Market, Net Seller, Battery	2548	2548
AAEE	-43	MUNI	199	199
Behind the meter DG	-3	QF	23	23
Net Load	3174	Solar	372	0
Transmission Losses	104	Existing 20-minute Demand Response	0	0
Pumps	0	Mothballed	35	0
Load + Losses + Pumps	3278	Total	3177	2770

3.3.6.1.4 Approved transmission projects modeled

- Borden 230 kV Voltage Support (Feb 2019)
- Kearney-Herndon 230 kV Line Reconductoring (May 2019)
- Gates #12 500/230 Transformer Bank addition (Dec 2019)
- Wilson 115 kV SVC (Dec 2019)
- Northern Fresno 115 kV Reinforcement (Revised scope – Mar 2020)
- Oro Loma 70 kV Reinforcement (May 2020)

3.3.6.2 Hanford Sub-area

Hanford is a Sub-area of the Fresno LCR Area.

3.3.6.2.1 Hanford LCR Sub-area Diagram

Figure 3.3-63 Hanford LCR Sub-area

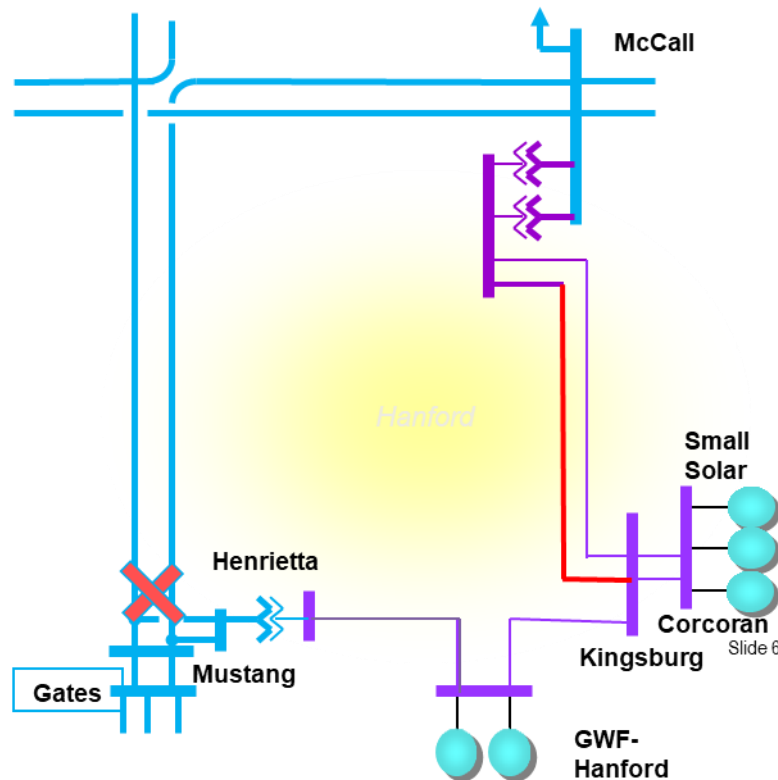

3.3.6.2.2 Hanford LCR Sub-area Load and Resources

Table 3.3-46 provides the forecast load and resources in Hanford LCR Sub-area in 2020. The list of generators within the LCR Sub-area are provided in Attachment A.

Table 3.3-46 Hanford LCR Sub-area 2020 Forecast Load and Resources

Load (MW)		Generation (MW)	NQC	At Peak
Gross Load	224	Market, Net Seller	133	133
AAEE	-3	MUNI	0	0
Behind the meter DG	-3	QF	0	0
Net Load	218	Solar	37	0
Transmission Losses	8	Existing 20-minute Demand Response	0	0

Pumps	0	Mothballed	0	0
Load + Losses + Pumps	226	Total	170	133

3.3.6.2.3 Hanford LCR Sub-area Hourly Profiles

Figure 3.3-64 illustrates the forecast 2020 profile for the summer peak, winter peak and spring off-peak days for the Hanford LCR Sub-area with the Category C (Multiple Contingency) transmission capability without resources. Figure 3.3-65 illustrates the forecast 2020 hourly profile for Hanford LCR Sub-area with the Category C (Multiple Contingency) transmission capability without resources.

Figure 3.3-64 Hanford LCR Sub-area 2020 Peak Day Forecast Profiles

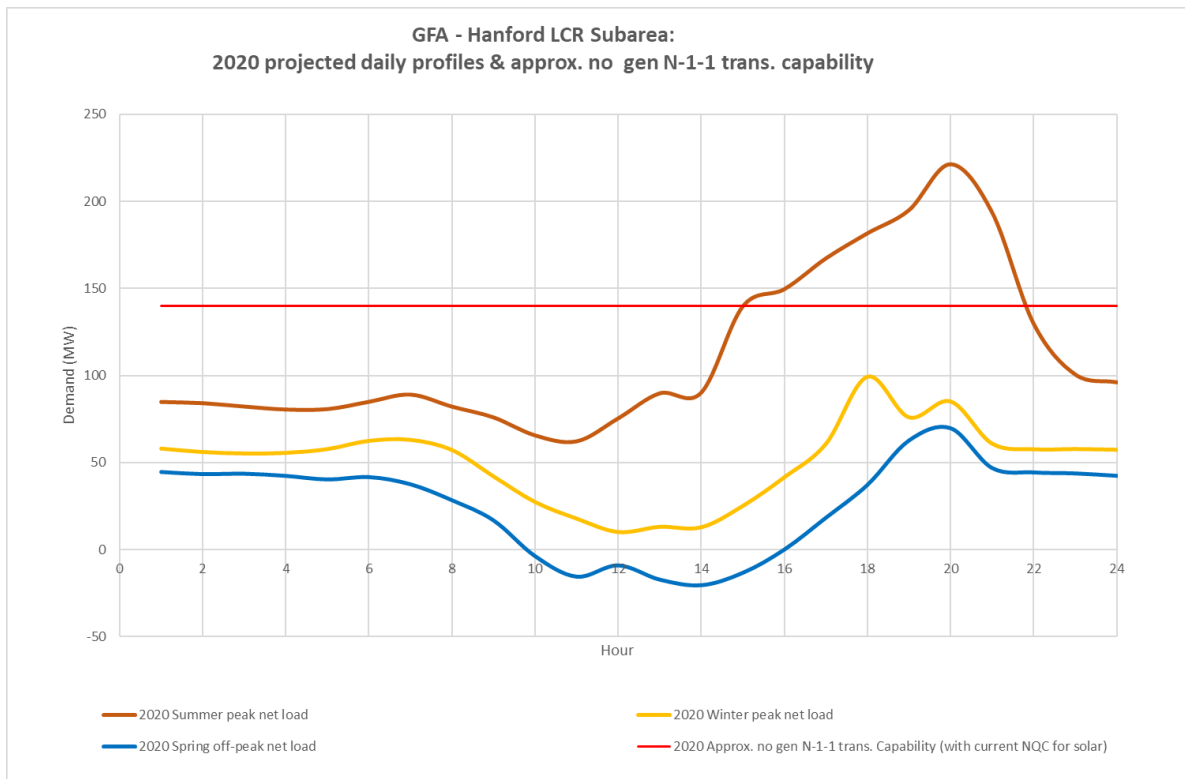
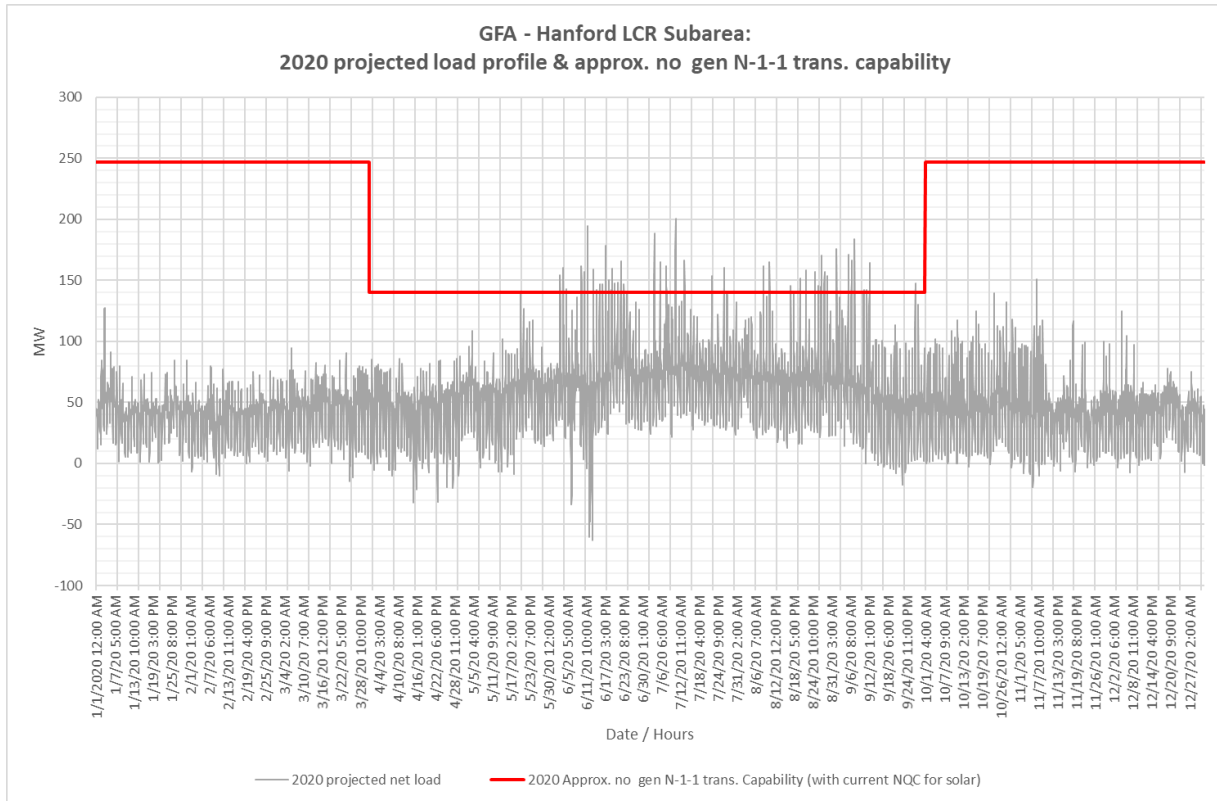

Figure 3.3-65 Hanford LCR Sub-area 2020 Forecast Hourly Profiles



3.3.6.2.4 Hanford LCR Sub-area Requirement

Table 3.3-47 identifies the sub-area requirements. There is no LCR requirement for Category B (Single Contingency) and the LCR Requirement for a Category C (Multiple Contingency) is 82 MW.

Table 3.3-47 Hanford LCR Sub-area Requirements

Year	Limit	Category	Limiting Facility	Contingency	LCR (MW) (Deficiency)
2020	First limit	B	None	None	0
2020	First Limit	C	McCall-Kingsburg #1 115 kV	Mustang-Gates #1 and #2 230 kV	82

3.3.6.2.5 Effectiveness factors:

All units within the Hanford Sub-area have the same effectiveness factor.

For most helpful procurement information please read procedure 2210Z Effectiveness Factors under 7110 (T-138Z) posted at: <http://www.aiso.com/Documents/2210Z.pdf>

3.3.6.3 Coalinga Sub-area

Coalinga is a Sub-area of the Fresno LCR Area.

3.3.6.3.1 Coalinga LCR Sub-area Diagram

Figure 3.3-66 Coalinga LCR Sub-area

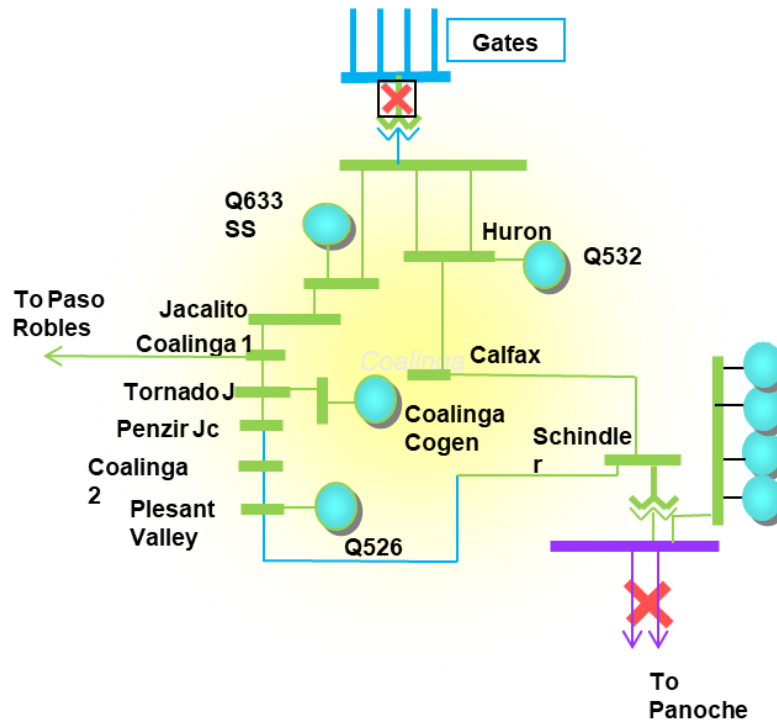

3.3.6.3.2 Coalinga LCR Sub-area Load and Resources

Table 3.3-48 provides the forecast load and resources in Coalinga LCR Sub-area in 2020. The list of generators within the LCR Sub-area are provided in Attachment A.

Table 3.3-48 Coalinga LCR Sub-area 2020 Forecast Load and Resources

Load (MW)		Generation (MW)	NQC	At Peak
Gross Load	90	Market, Net Seller	0	0
AAEE	-1	MUNI	0	0
Behind the meter DG	0	QF	3	3
Net Load	89	Solar	38	0
Transmission Losses	2	Existing 20-minute Demand Response	0	0
Pumps	0	Mothballed	34	0
Load + Losses + Pumps	91	Total	75	3

3.3.6.3.3 Coalinga LCR Sub-area Hourly Profiles

Figure 3.3-67 illustrates the forecast 2020 profile for the summer peak, winter peak and spring off-peak days for the Coalinga LCR Sub-area with the Category C (Multiple Contingency) transmission capability without resources. Figure 3.3-68 illustrates the forecast 2020 hourly profile for Coalinga LCR Sub-area with the Category C (Multiple Contingency) transmission capability without resources.

Figure 3.3-67 Coalinga LCR Sub-area 2020 Peak Day Forecast Profiles

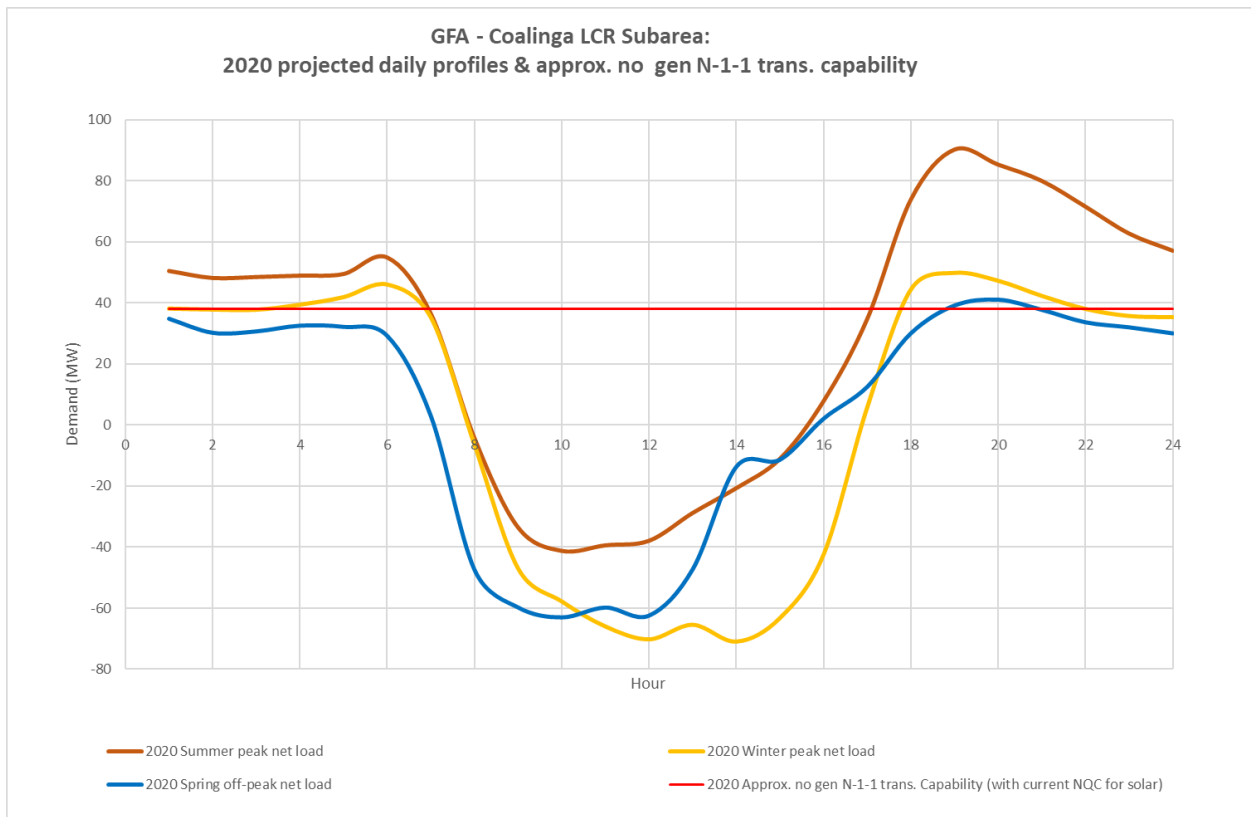
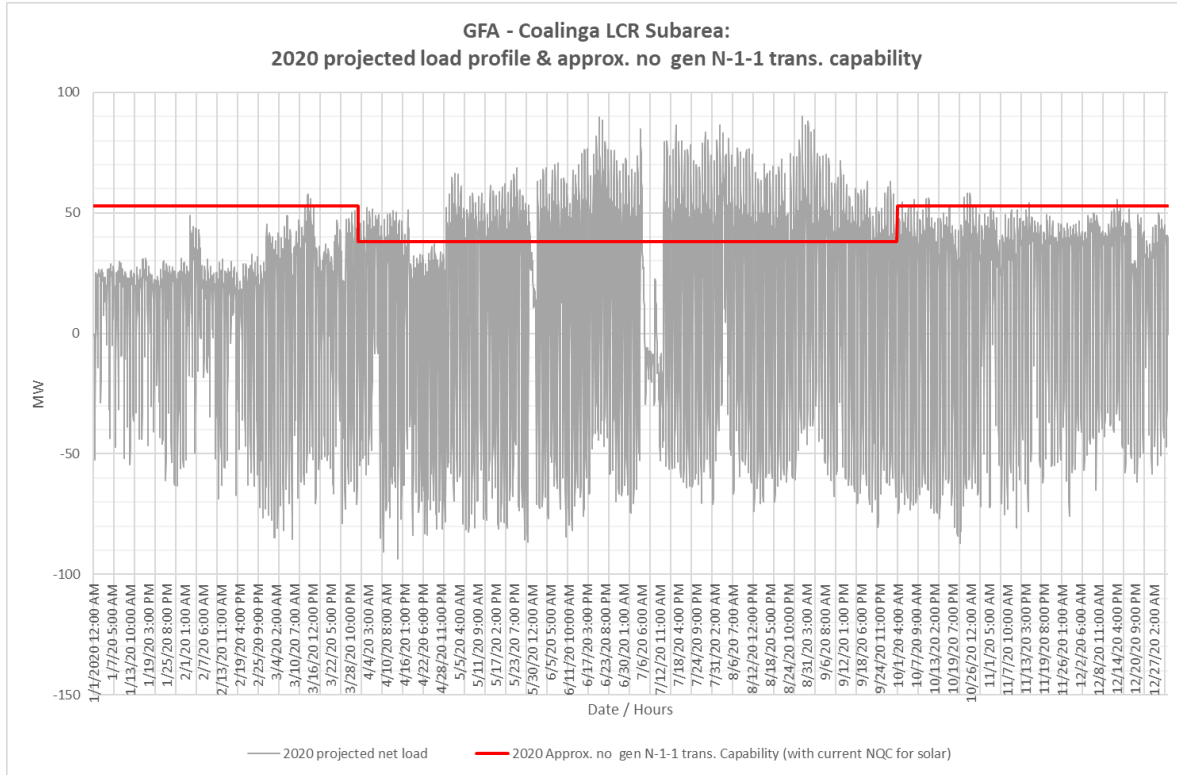

Figure 3.3-68 Coalinga LCR Sub-area 2020 Forecast Hourly Profiles



3.3.6.3.4 Coalinga LCR Sub-area Requirement

Table 3.3-49 identifies the sub-area requirements. There is no LCR requirement for Category B (Single Contingency) and the LCR Requirement for a Category C (Multiple Contingency) is 35 MW including a 32 MW at peak deficiency. This sub-area is not deficient in NQC.

Table 3.3-49 Coalinga LCR Sub-area Requirements

Year	Limit	Category	Limiting Facility	Contingency	LCR (MW) (Deficiency)
2020	First Limit	B	None	None	0
2020	First Limit	C	Voltage Instability	Gates #5 230/70 kV Tx followed by Panoche-Schindler #1 & #2 115 kV DCTL	35 (32 Peak)

3.3.6.3.5 Effectiveness factors:

All units within the Coalinga Sub-area have the same effectiveness factor.

For most helpful procurement information please read procedure 2210Z Effectiveness Factors under 7110 (T-138Z) posted at: <http://www.aiso.com/Documents/2210Z.pdf>

3.3.6.4 Borden Sub-area

Borden is a Sub-area of the Fresno LCR Area.

3.3.6.4.1 Borden LCR Sub-area Diagram

Figure 3.3-69 Borden LCR Sub-area

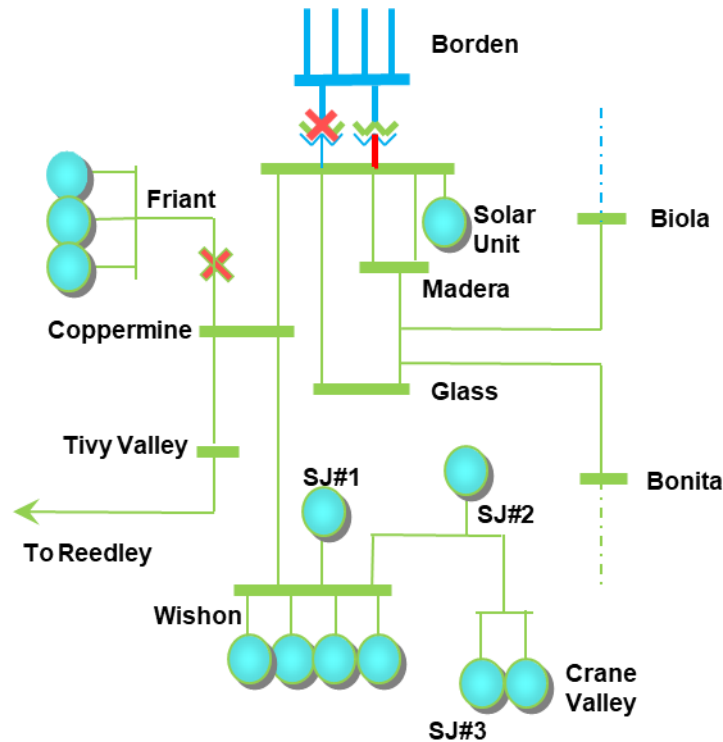

3.3.6.4.2 Borden LCR Sub-area Load and Resources

Table 3.3-50 provides the forecast load and resources in Borden LCR Sub-area in 2020. The list of generators within the LCR Sub-area are provided in Attachment A.

Table 3.3-50 Borden LCR Sub-area 2020 Forecast Load and Resources

Load (MW)		Generation (MW)	NQC	At Peak
Gross Load	143	Market	35	35
AAEE	-2	MUNI	0	0
Behind the meter DG	0	QF	0	0
Net Load	141	LTPP Preferred Resources	0	0
Transmission Losses	2	Existing 20-minute Demand Response	0	0
Pumps	0	Mothballed	0	0
Load + Losses + Pumps	143	Total	35	35

3.3.6.4.3 Borden LCR Sub-area Hourly Profiles

Figure 3.3-70 illustrates the forecast 2020 profile for the summer peak, winter peak and spring off-peak days for the Borden LCR Sub-area with the Category C (Multiple Contingency) transmission capability without resources. Figure 3.3-71 illustrates the forecast 2020 hourly profile for Borden LCR Sub-area with the Category C (Multiple Contingency) transmission capability without resources.

Figure 3.3-70 Borden LCR Sub-area 2020 Peak Day Forecast Profiles

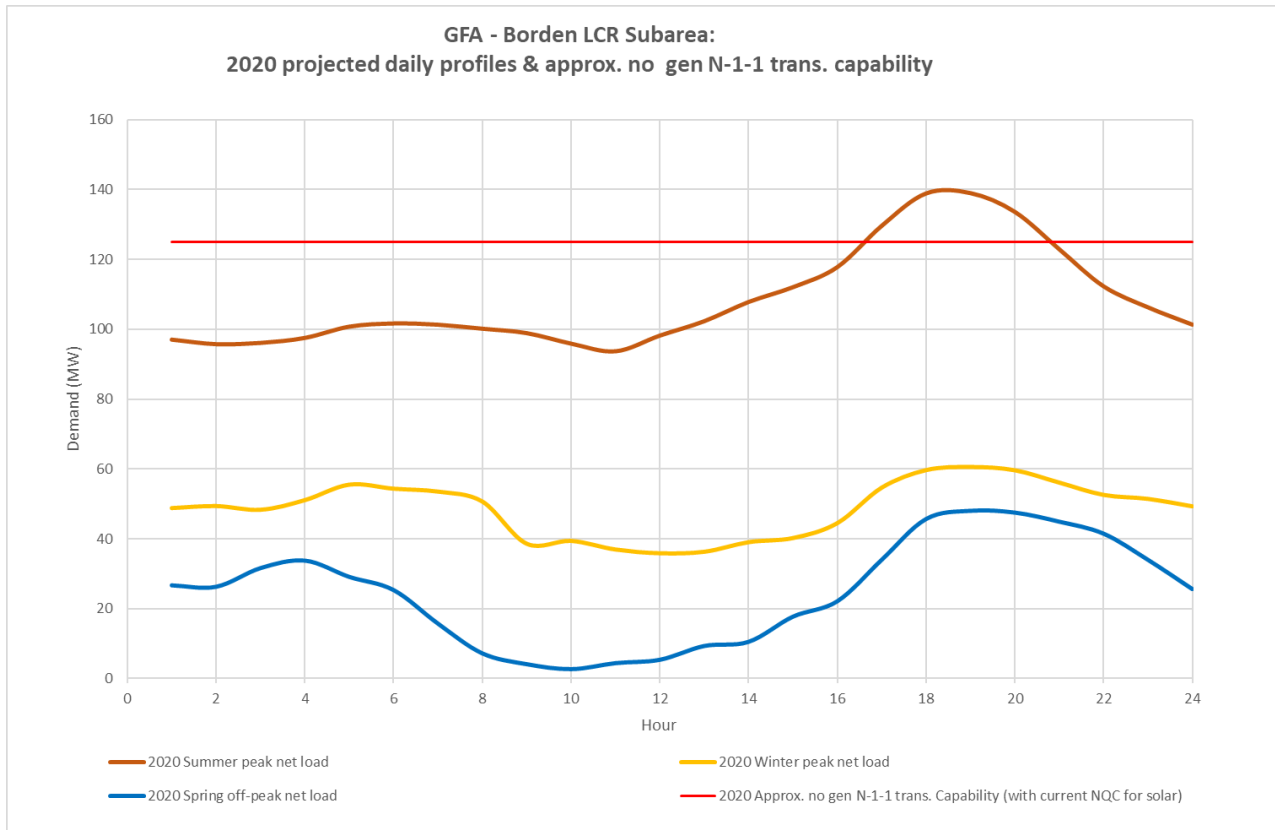
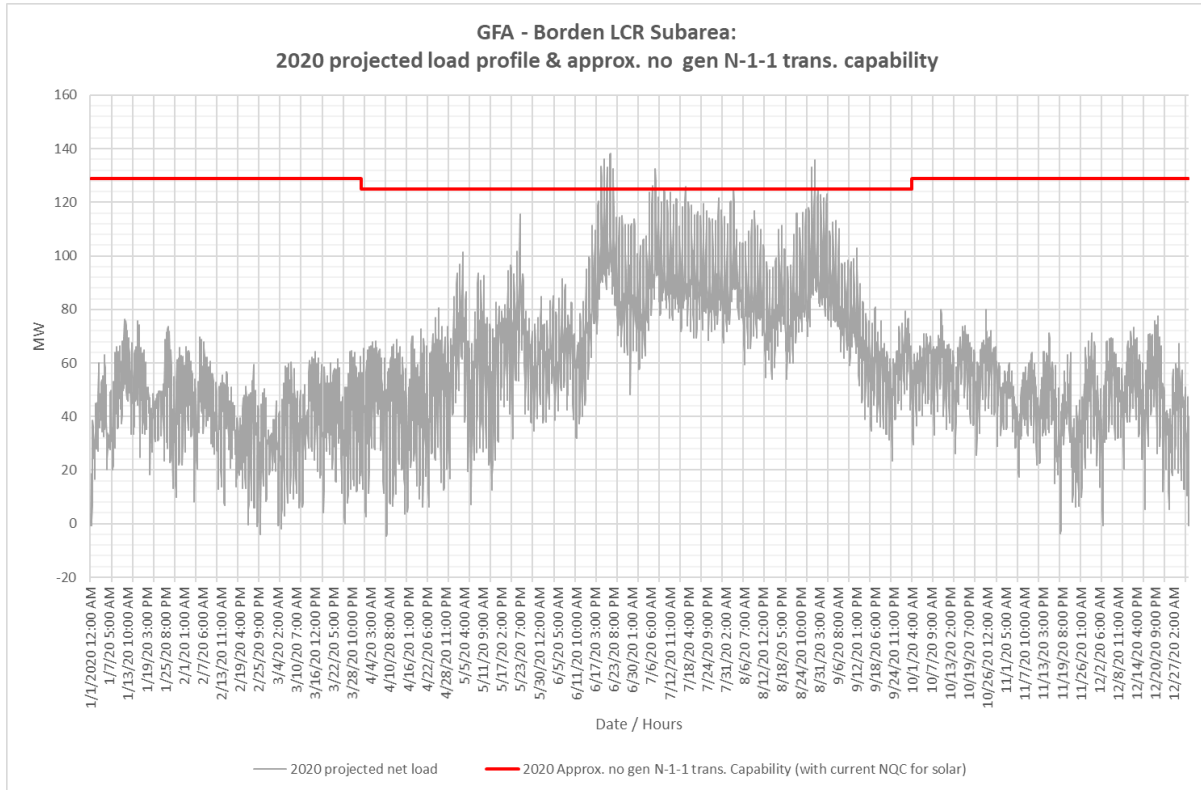

Figure 3.3-71 Borden LCR Sub-area 2020 Forecast Hourly Profiles



3.3.6.4.4 Borden LCR Sub-area Requirement

Table 3.3-51 identifies the sub-area LCR requirements. The LCR requirement for Category B (Single Contingency) is 13 MW and the LCR requirement for Category C (Multiple Contingency) is 19 MW.

Table 3.3-51 Borden LCR Sub-area Requirements

Year	Limit	Category	Limiting Facility	Contingency	LCR (MW) (Deficiency)
2020	First Limit	B	Borden 230/70 kV TB # 1	Borden 230/70 kV # 4	13
2020	First Limit	C	Borden #1 230/70 kV Tx	Friant - Coppermine 70 kV & Borden #2 230/70 kV Tx	19

3.3.6.4.5 Effectiveness factors:

All units within the Borden Sub-area have the same effectiveness factor.

For most helpful procurement information please read procedure 2210Z Effectiveness Factors under 7110 (T-138Z) posted at: <http://www.caiso.com/Documents/2210Z.pdf>

3.3.6.5 Reedley Sub-area

Reedley is a Sub-area of the Fresno LCR Area.

3.3.6.5.1 Reedley LCR Sub-area Diagram

Figure 3.3-72 Reedley LCR Sub-area

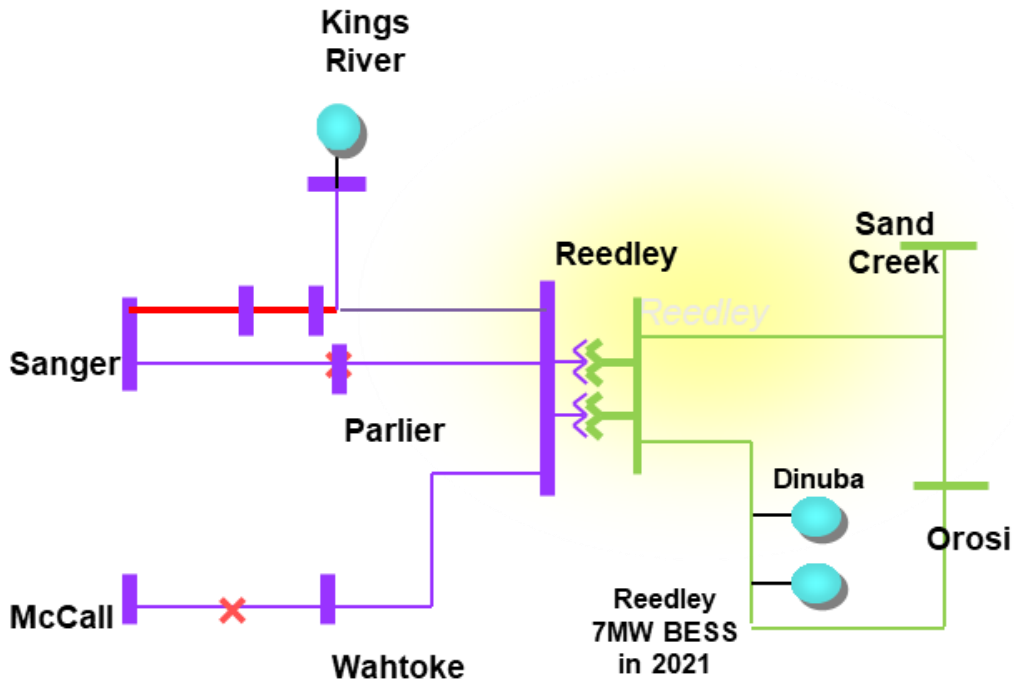

3.3.6.5.2 Reedley LCR Sub-area Load and Resources

Table 3.3-52 provides the forecast load and resources in Coalinga LCR Sub-area in 2020. The list of generators within the LCR Sub-area are provided in Attachment A.

Table 3.3-52 Reedley LCR Sub-area 2020 Forecast Load and Resources

Load (MW)		Generation (MW)	NQC	At Peak
Gross Load	215	Market, Net Seller	54	54
AAEE	-3	MUNI	0	0
Behind the meter DG	0	QF	0	0
Net Load	212	LTPP Preferred Resources	0	0
Transmission Losses	31	Existing 20-minute Demand Response	0	0

Pumps	0	Mothballed	0	0
Load + Losses + Pumps	243	Total	54	54

3.3.6.5.3 Reedley LCR Sub-area Hourly Profiles

Figure 3.3-73 illustrates the forecast 2020 profile for the summer peak, winter peak and spring off-peak days for the Reedley LCR Sub-area with the Category C (Multiple Contingency) transmission capability without resources. Figure 3.3-74 illustrates the forecast 2020 hourly profile for Reedley LCR Sub-area with the Category C (Multiple Contingency) transmission capability without resources.

Figure 3.3-73 Reedley LCR Sub-area 2020 Peak Day Forecast Profiles

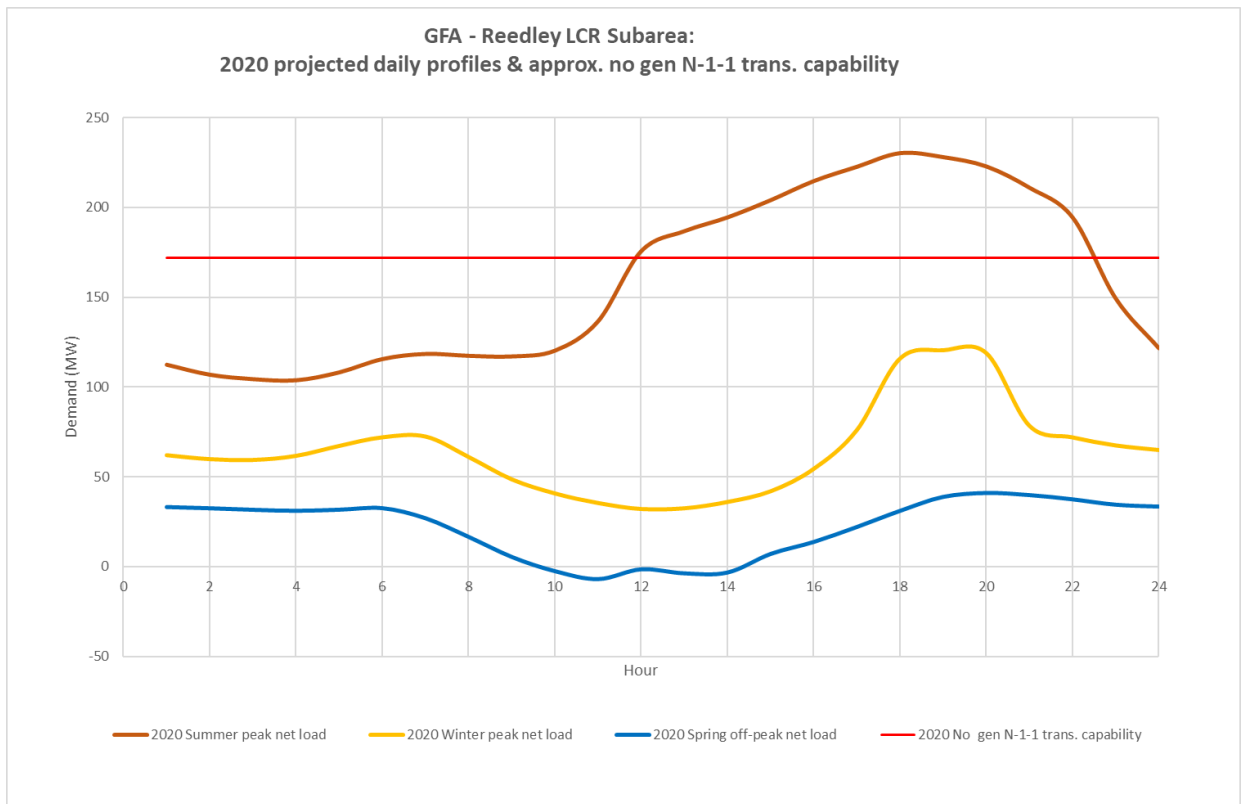
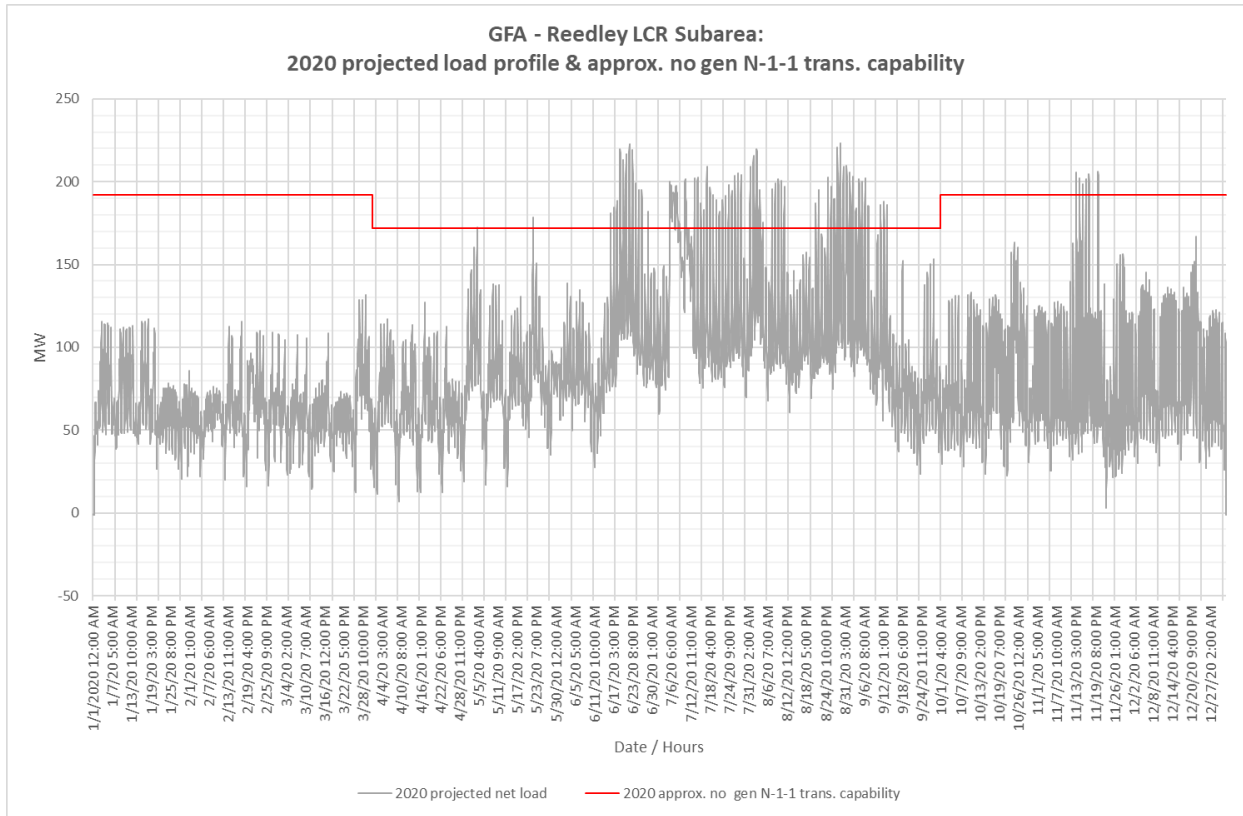

Figure 3.3-74 Reedley LCR Sub-area 2020 Forecast Hourly Profiles



3.3.6.5.4 Reedley LCR Sub-area Requirement

Table 3.3-53 identifies the sub-area requirements. There is no LCR requirement for Category B (Single Contingency) and the LCR Requirement for a Category C (Multiple Contingency) is 35 MW.

Table 3.3-53 Reedley LCR Sub-area Requirements

Year	Limit	Category	Limiting Facility	Contingency	LCR (MW) (Deficiency)
2020	First Limit	B	None	None	0
2020	First Limit	C	Kings River-Sanger-Reedley 115 kV	McCall-Reedley 115 kV & Sanger-Reedley 115 kV	35

3.3.6.5.5 Effectiveness factors:

All units within the Reedley Sub-area have the same effectiveness factor.

For most helpful procurement information please read procedure 2210Z Effectiveness Factors under 7110 (T-138Z) posted at: <http://www.caiso.com/Documents/2210Z.pdf>

3.3.6.6 Herndon Sub-area

Herndon is a Sub-area of the Fresno LCR Area.

3.3.6.6.1 Herndon LCR Sub-area Diagram

Figure 3.3-75 Herndon LCR Sub-area

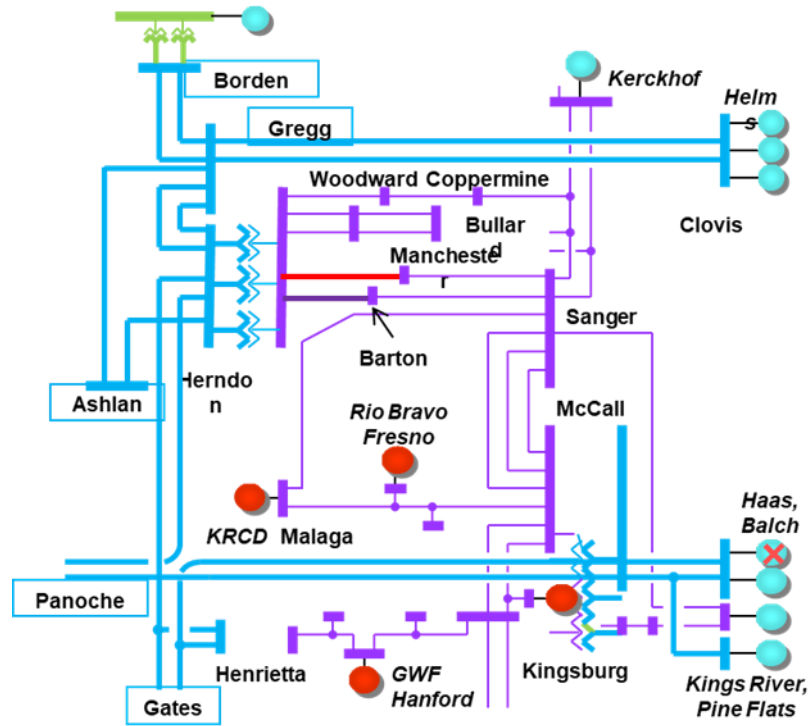

3.3.6.6.2 Herndon LCR Sub-area Load and Resources

Table 3.3-54 provides the forecast load and resources in Herndon LCR Sub-area in 2020. The list of generators within the LCR Sub-area are provided in Attachment A.

Table 3.3-54 Herndon LCR Sub-area 2020 Forecast Load and Resources

Load (MW)		Generation (MW)	NQC	At Peak
Gross Load	1562	Market, Net Seller	962	962
AAEE	-19	MUNI	80	80
Behind the meter DG	-3	QF	0	0
Net Load	1540	Solar	47	0
Transmission Losses	29	Existing 20-minute Demand Response	0	0
Pumps	0	Mothballed	0	0
Load + Losses + Pumps	1569	Total	1089	1042

3.3.6.6.3 Herndon LCR Sub-area Hourly Profiles

Figure 3.3-76 illustrates the forecast 2020 profile for the summer peak, winter peak and spring off-peak days for the Herndon LCR Sub-area with the Category C (Multiple Contingency) transmission capability without resources. Figure 3.3-77 illustrates the forecast 2020 hourly profile for Herndon LCR Sub-area with the Category C (Multiple Contingency) transmission capability without resources.

Figure 3.3-76 Herndon LCR Sub-area 2020 Peak Day Forecast Profiles

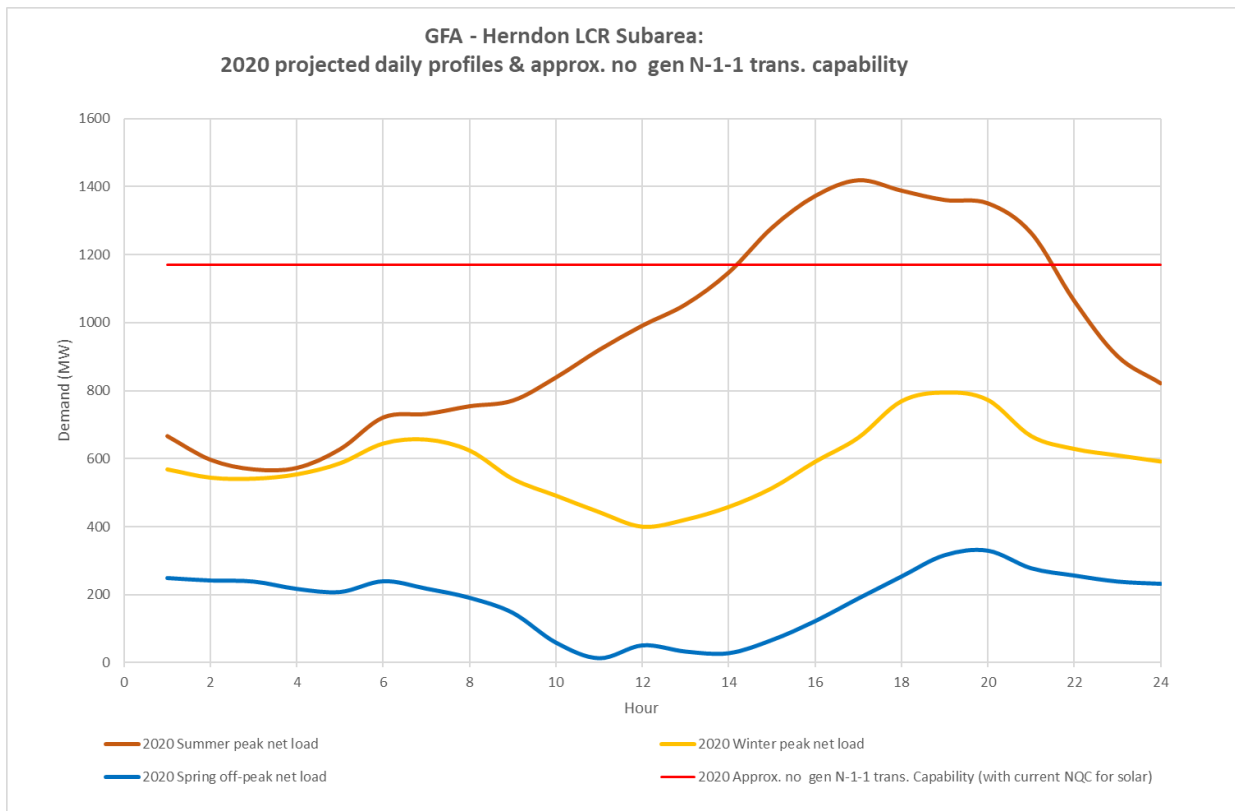
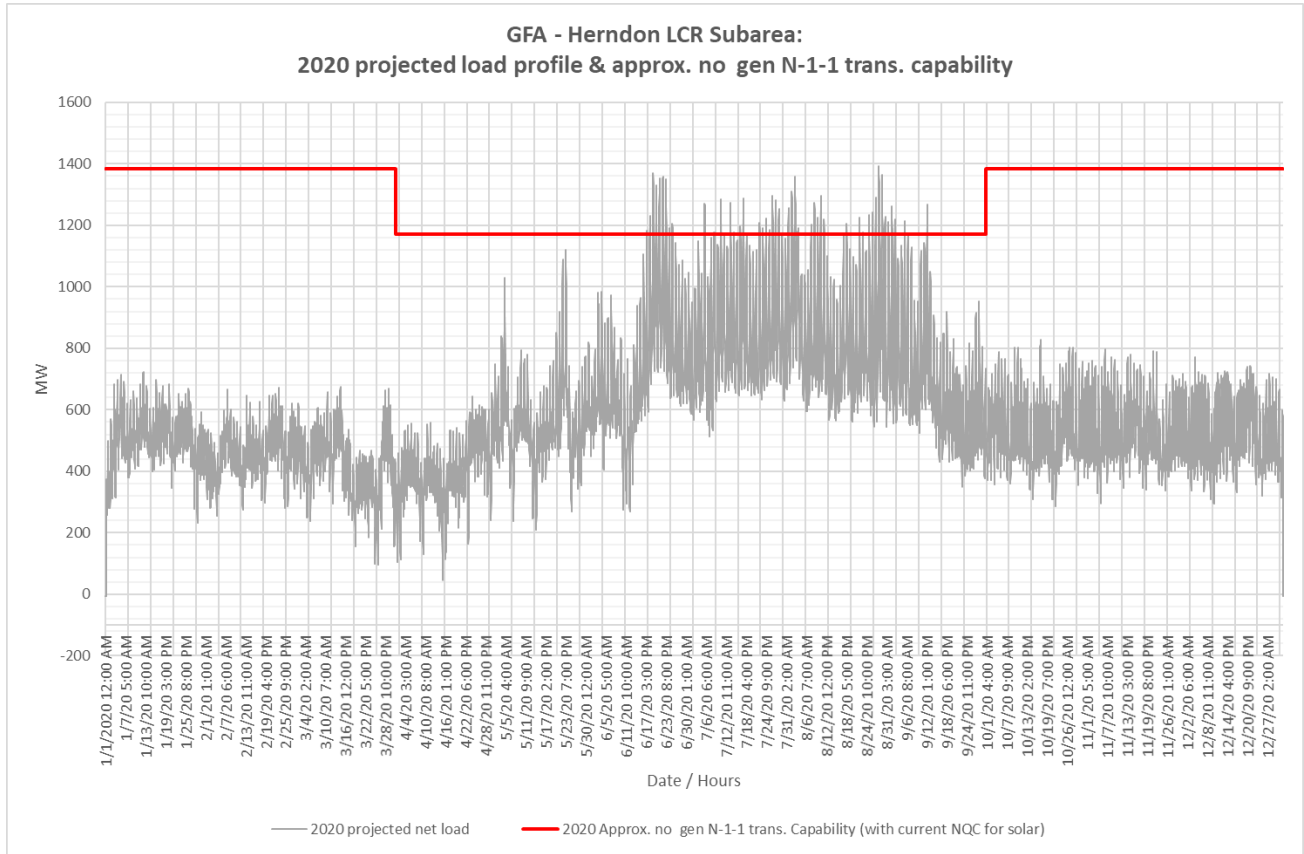

Figure 3.3-77 Herndon LCR Sub-area 2020 Forecast Hourly Profiles



3.3.6.6.4 Herndon LCR Sub-area Requirement

Table 3.3-55 identifies the sub-area LCR requirements. The LCR requirement for Category B (Single Contingency) is not binding and the LCR Requirement for a Category C (Multiple Contingency) is 436 MW.

Table 3.3-55 Herndon LCR Sub-area Requirements

Year	Limit	Category	Limiting Facility	Contingency	LCR (MW) (Deficiency)
2020	First limit	B	Herndon-Manchester 115 kV	Balch Unit 1 & Herndon-Barton 115 kV	Not Binding
2020	First limit	C	Herndon-Manchester 115 kV	Herndon-Woodward 115 kV line & Herndon-Barton 115 kV line	436

3.3.6.6.5 **Effectiveness factors:**

Effective factors for generators in the Herndon LCR Sub-area are in Attachment B table titled [Herndon](#).

For other helpful procurement information please read procedure 2210Z Effectiveness Factors under 7430 (T-129) posted at: <http://www.caiso.com/Documents/2210Z.pdf>

3.3.6.7 **Fresno Overall area**

3.3.6.7.1 **Fresno LCR area Diagram**

Figure 3.3-78 Fresno LCR area

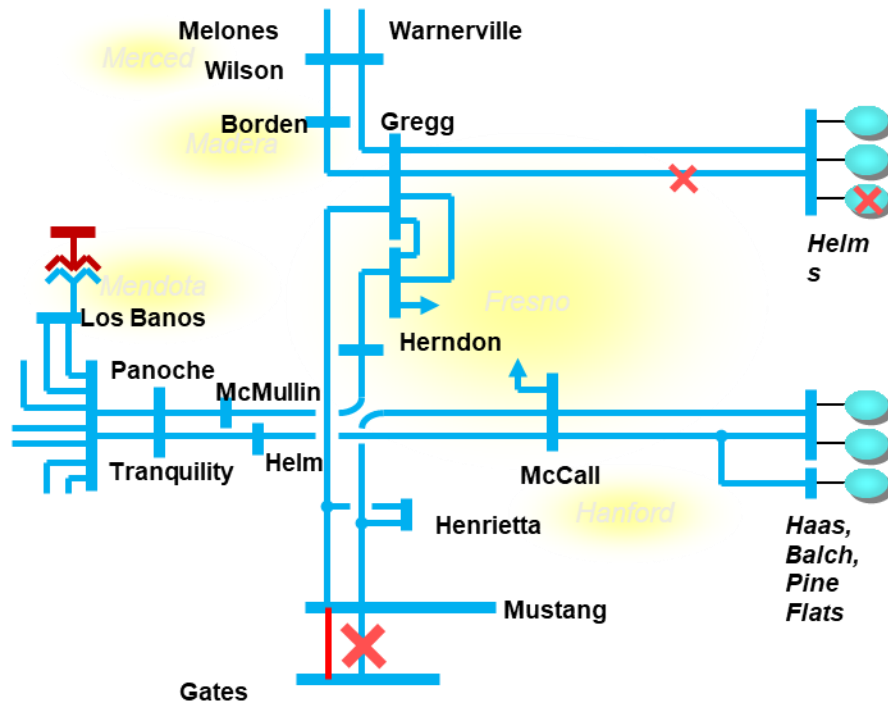

3.3.6.7.2 **Fresno Overall LCR area Load and Resources**

Table 3.3-45 provides the forecast load and resources in Fresno LCR area in 2020. The list of generators within the LCR Sub-area are provided in Attachment A.

3.3.6.7.3 **Fresno Overall LCR area Hourly Profiles**

Figure 3.3-79 illustrates the forecast 2020 profile for the summer peak, winter peak and spring off-peak days for the Fresno Overall LCR area with the Category C (Multiple Contingency) transmission capability without resources. Figure 3.3-80 illustrates the forecast 2020 hourly profile for Wilson LCR Sub-area with the Category C (Multiple Contingency) transmission capability without resources.

Figure 3.3-79 Fresno LCR area 2020 Peak Day Forecast Profiles

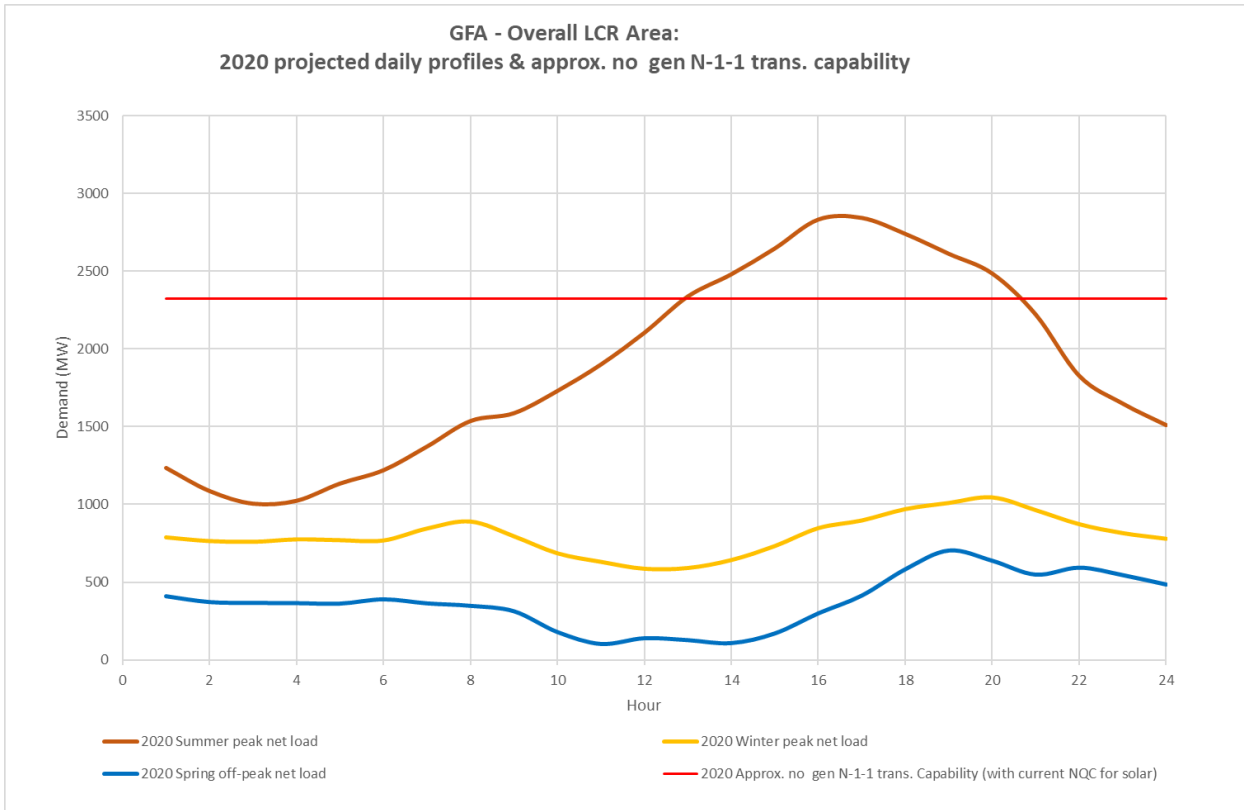
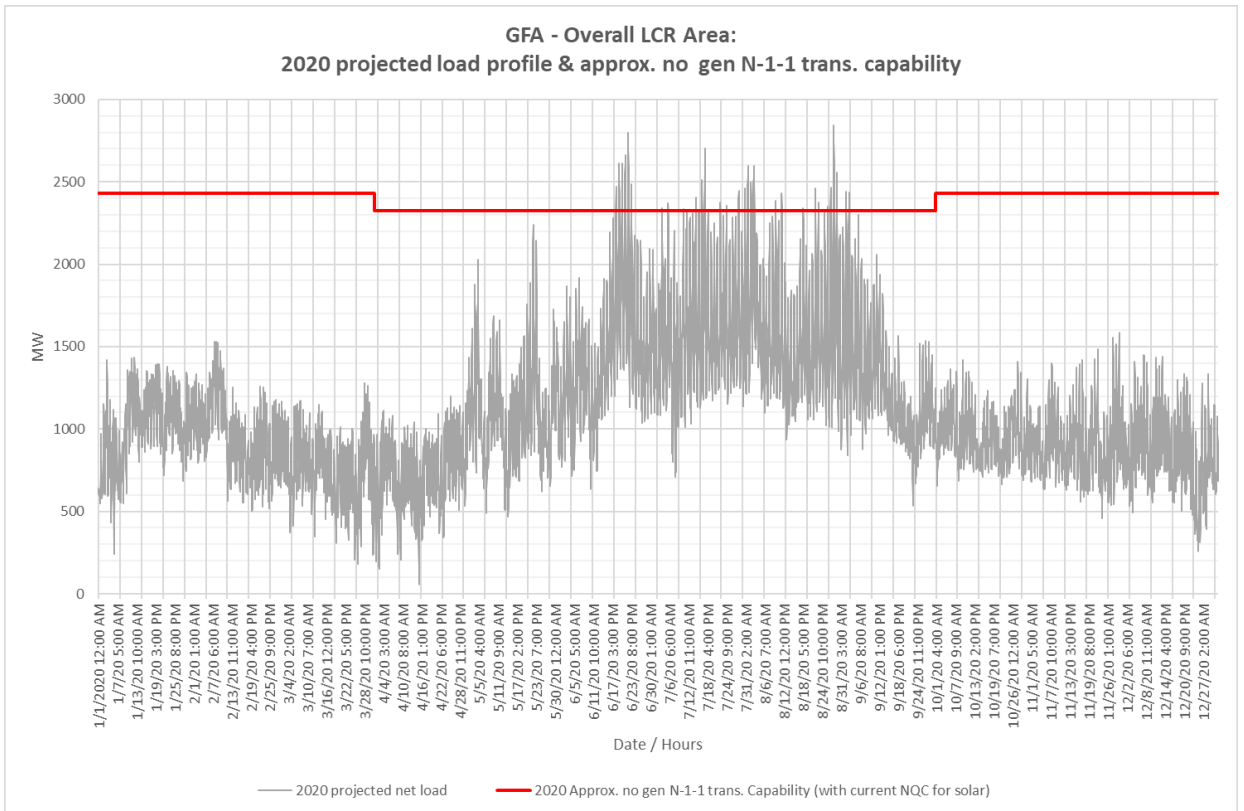

Figure 3.3-80 Fresno LCR area 2020 Forecast Hourly Profiles



3.3.6.7.4 Fresno Overall LCR Area Requirement

Table 3.3-56 identifies the area LCR requirements. The LCR requirement for Category B (Single Contingency) is 1694 MW and the LCR Requirement for a Category C (Multiple Contingency) is 1694 MW.

Table 3.3-56 Fresno Overall LCR Area Requirements

Year	Limit	Category	Limiting Facility	Contingency	LCR (MW) (Deficiency)
2020	First limit	B	Remaining Gates-Mustang 230 kV	Gates-Mustang 230 kV #1 or #2 with one Helms unit out	1694
2020	First limit	C	Remaining Gates-Mustang 230 kV	Gates-Mustang #1 or #2 230 kV and Helms-Gregg #1 230 kV	1694

3.3.6.7.5 Effectiveness factors:

For most helpful procurement information please read procedure 2210Z Effectiveness Factors under 7430 (T-129) posted at: <http://www.caiso.com/Documents/2210Z.pdf>

3.3.6.7.6 Changes compared to 2019 requirements

Compared with 2019 the load forecast increased by 208 MW and the LCR has increased by 24 MW, due to load increase.

3.3.7 Kern Area

3.3.7.1 Area Definition:

The transmission facilities coming into the Kern PP sub-area are:

- Midway-Kern PP #1 230 kV Line
- Midway-Kern PP #3 230 kV Line
- Midway-Kern PP #4 230 kV Line
- Famoso-Lerdo 115 kV Line (Normal Open)
- Wasco-Famoso 70 kV Line (Normal Open)
- Copus-Old River 70 kV Line (Normal Open)
- Copus-Old River 70 kV Line (Normal Open)
- Weedpatch CB 32 70 kV (Normal Open)

The substations that delineate the Kern-PP sub-area are:

- Midway 230 kV is out and Bakersfield 230 kV is in
- Midway 230 kV is out and Stockdale 230 kV is in
- Midway 230 kV is out Kern PP 230 kV is in
- Famoso 115 kV is out Cawelo 115 kV is in
- Wasco 70 kV is out Mc Farland 70 kV is in
- Copus 70 kV is out, South Kern Solar 70 kV is in
- Lakeview 70 kV is out, San Emidio Junction 70 kV is in
- Weedpatch 70 kV is out, Wellfield 70 kV is in

3.3.7.1.1 Kern LCR Area Diagram

Figure 3.3-81 Kern LCR Area

SR

3.3.7.1.2 Kern LCR Area Load and Resources

Table 3.3-57 provides the forecast load and resources in Kern LCR Area in 2020. The list of generators within the LCR Sub-area are provided in Attachment A.

In year 2020 the estimated time of local area peak is 19:20 PM.

At the local area peak time the estimated, behind the meter, solar output is 0.00%.

At the local area peak time the estimated, ISO metered, solar output is 0.00%.

If required, all non-solar technology type resources are dispatched at NQC.

Table 3.3-57 Kern LCR Area 2020 Forecast Load and Resources

Load (MW)		Generation (MW)	NQC	At Peak
Gross Load	1170	Market, Net Seller	354	354
AAEE	-15	MUNI	0	0
Behind the meter DG	0	QF	8	8
Net Load	1155	Solar	103	0
Transmission Losses	14	Existing 20-minute Demand Response	0	0
Pumps	0	Mothballed	0	0
Load + Losses + Pumps	1169	Total	465	362

3.3.7.1.3 Approved transmission projects modeled

None

3.3.7.2 Kern 70 kV Sub-area

Kern 70 kV is a Sub-area of the Kern LCR Area.

3.3.7.2.1 Kern 70 kV LCR Sub-area Diagram

Figure 3.3-82 Kern 70 kV LCR Sub-area

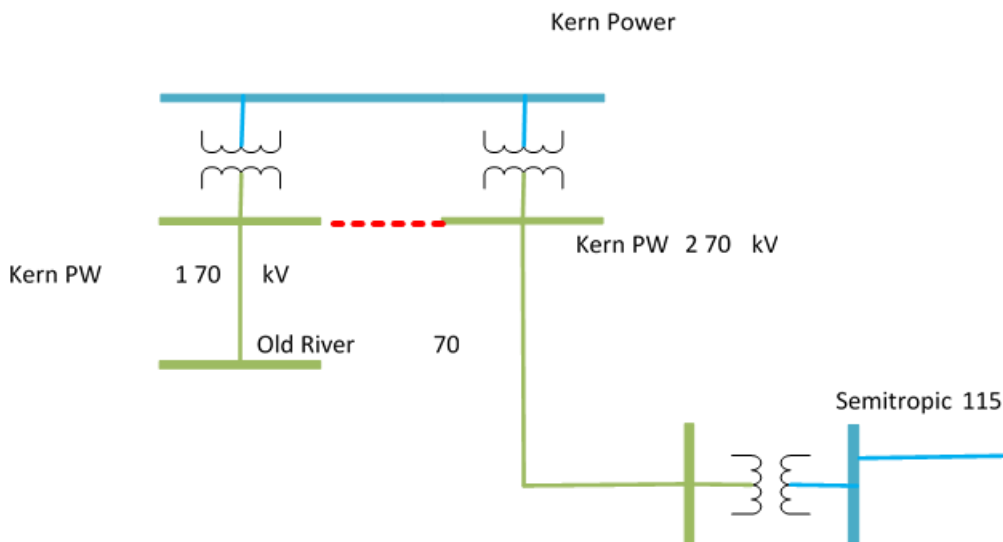

3.3.7.2.2 Kern 70 kV LCR Sub-area Load and Resources

Table 3.3-58 provides the forecast load and resources in Kern 70 kV LCR Sub-area in 2020. The list of generators within the LCR Sub-area are provided in Attachment A.

Table 3.3-58 Kern 70 kV LCR Sub-area 2020 Forecast Load and Resources

Load (MW)		Generation (MW)	NQC	At Peak
Gross Load	147	Market, Net Seller	4	4
AAEE	-2	MUNI	0	0
Behind the meter DG	0	QF	0	0
Net Load	145	Solar	20	0
Transmission Losses	2	Existing 20-minute Demand Response	0	0
Pumps	0	Mothballed	0	0
Load + Losses + Pumps	147	Total	24	4

3.3.7.2.3 Kern 70 kV LCR Sub-area Hourly Profiles

Figure 3.3-85 illustrates the forecast 2020 profile for the summer peak, winter peak and spring off-peak days for the Kern 70 kV LCR Sub-area with the Category C (Multiple Contingency) transmission capability without resources. Figure 3.3-86 illustrates the forecast 2020 hourly profile for Kern 70 kV LCR Sub-area with the Category C (Multiple Contingency) transmission capability without resources.

Figure 3.3-83 Kern 70 kV LCR Sub-area 2020 Peak Day Forecast Profiles

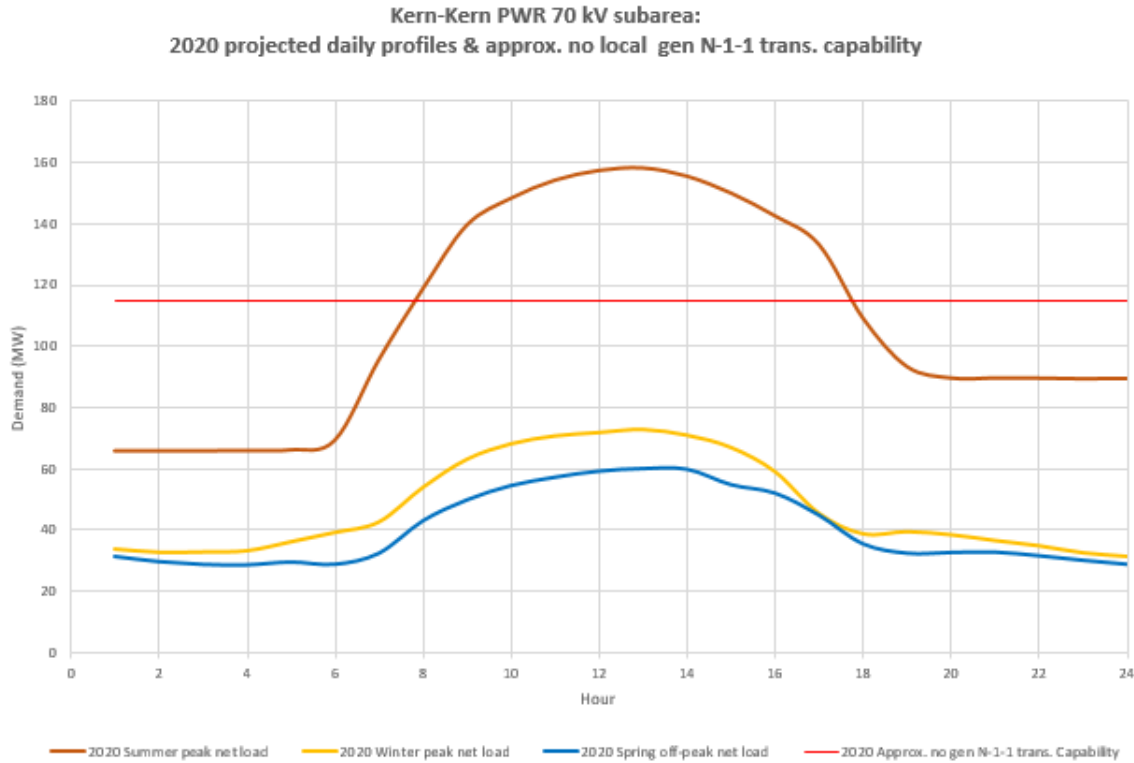
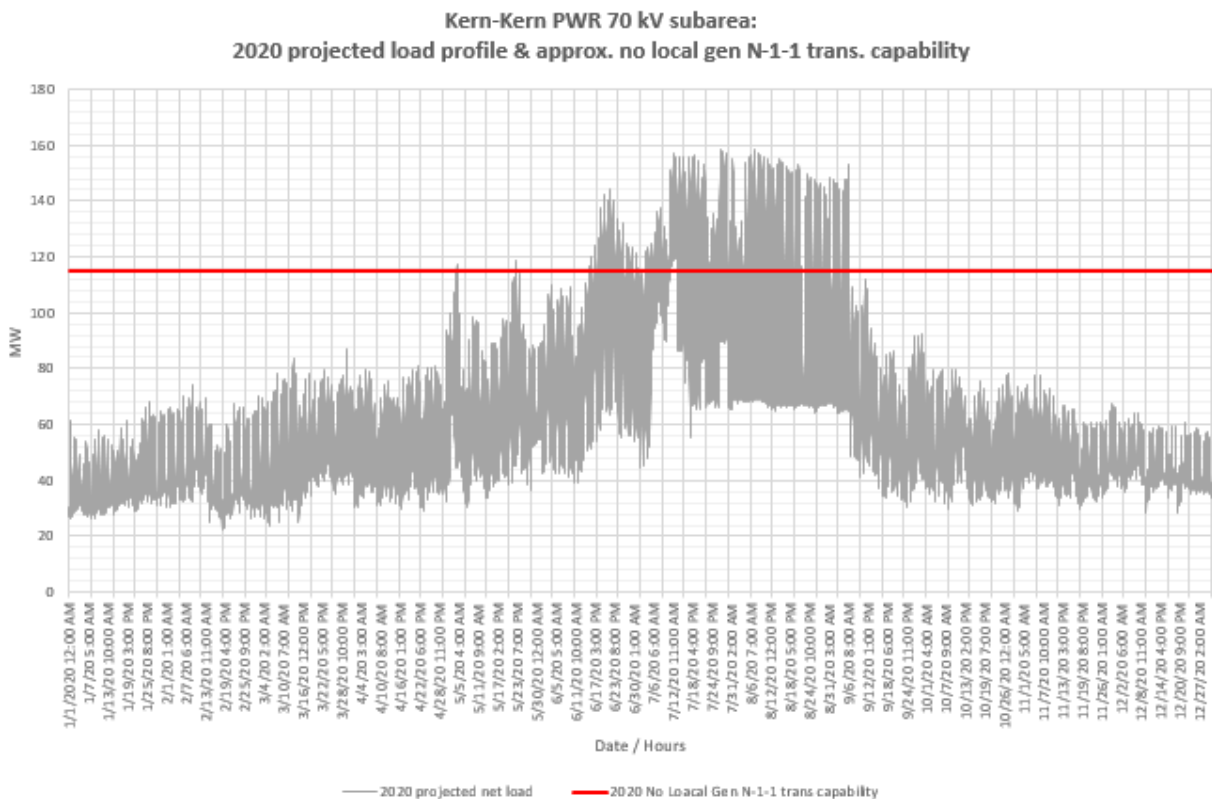

Figure 3.3-84 Kern 70 kV LCR Sub-area 2020 Forecast Hourly Profiles



3.3.7.2.4 Kern 70 kV LCR Sub-area Requirement

Table 3.3-59 identifies the sub-area LCR requirements. The LCR requirement for Category B (Single Contingency) and Category C (Multiple Contingency) are the same 65 MW including a 41 MW NQC deficiency or 61 MW at peak deficiency.

Table 3.3-59 Kern 70 kV LCR Sub-area Requirements

Year	Limit	Category	Limiting Facility	Contingency	LCR (MW) (Deficiency)
2020	First Limit	B	None	None	0
2020	First Limit	C	Kern PW2 to Kern PW1 70 kV Bus Tie	Kern PW2 #1 115/70 T/F & Midway-Smyrna-Semitropic 115 kV	65 (41 NQC/ 61 Peak)

3.3.7.2.5 Effectiveness factors:

All units within the Kern 70 kV Sub-area have the same effectiveness factor.

For most helpful procurement information please read procedure 2210Z Effectiveness Factors under 7110 (T-138Z) posted at: <http://www.caiso.com/Documents/2210Z.pdf>

3.3.7.3 Westpark Sub-area

Westpark is a Sub-area of the Kern LCR Area.

3.3.7.3.1 Westpark LCR Sub-area Diagram

Please see Figure 3.3-81 for Westpark Sub-area diagram.

3.3.7.3.2 Westpark LCR Sub-area Load and Resources

Table 3.3-60 provides the forecast load and resources in Westpark LCR Sub-area in 2020. The list of generators within the LCR Sub-area are provided in Attachment A.

Table 3.3-60 Westpark LCR Sub-area 2020 Forecast Load and Resources

Load (MW)		Generation (MW)	NQC	At Peak
Gross Load	166	Market, Net Seller	47	47
AAEE	-2	MUNI	0	0
Behind the meter DG	0	QF	0	0
Net Load	164	LTPP Preferred Resources	0	0

Transmission Losses	0	Existing 20-minute Demand Response	0	0
Pumps	0	Mothballed	0	0
Load + Losses + Pumps	164	Total	47	47

3.3.7.3.3 Westpark LCR Sub-area Hourly Profiles

Figure 3.3-85 illustrates the forecast 2020 profile for the summer peak, winter peak and spring off-peak days for the Westpark LCR Sub-area with the Category C (Multiple Contingency) transmission capability without resources. Figure 3.3-86 illustrates the forecast 2020 hourly profile for Westpark LCR Sub-area with the Category C (Multiple Contingency) transmission capability without resources.

Figure 3.3-85 Westpark LCR Sub-area 2020 Peak Day Forecast Profiles

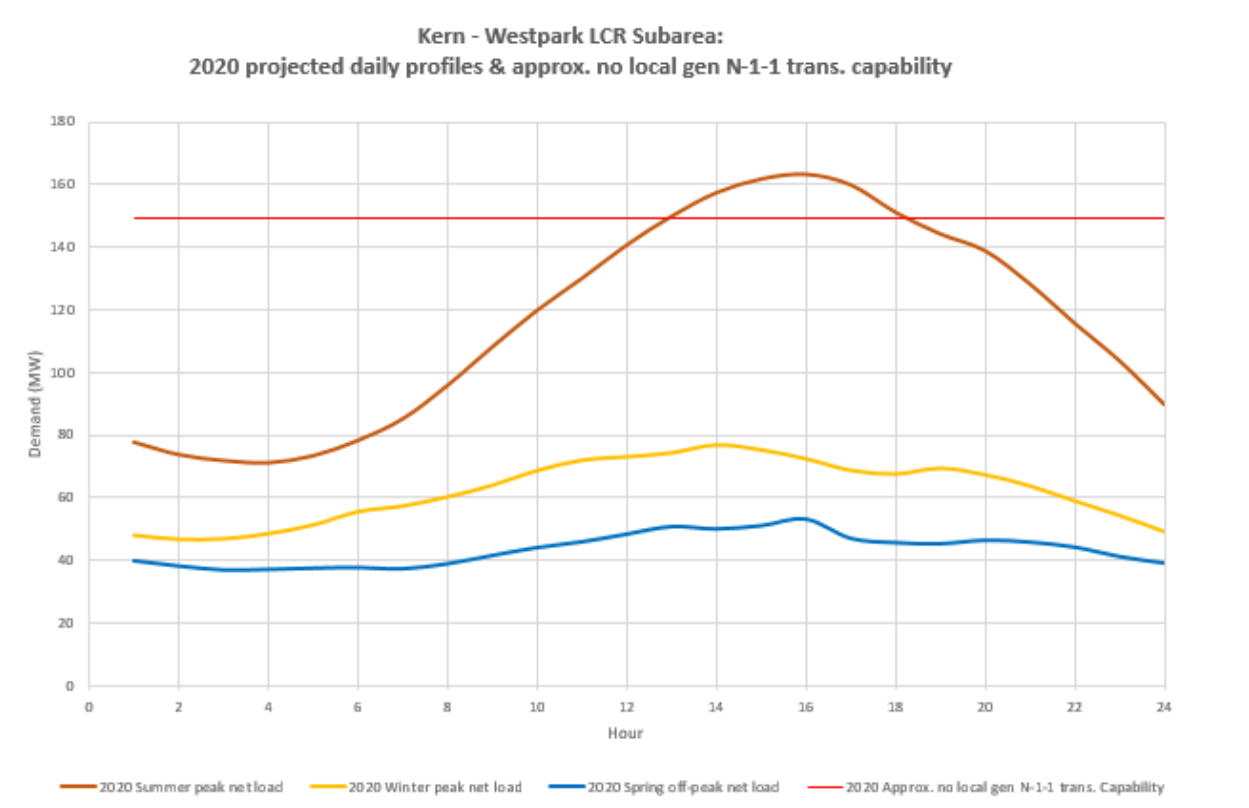
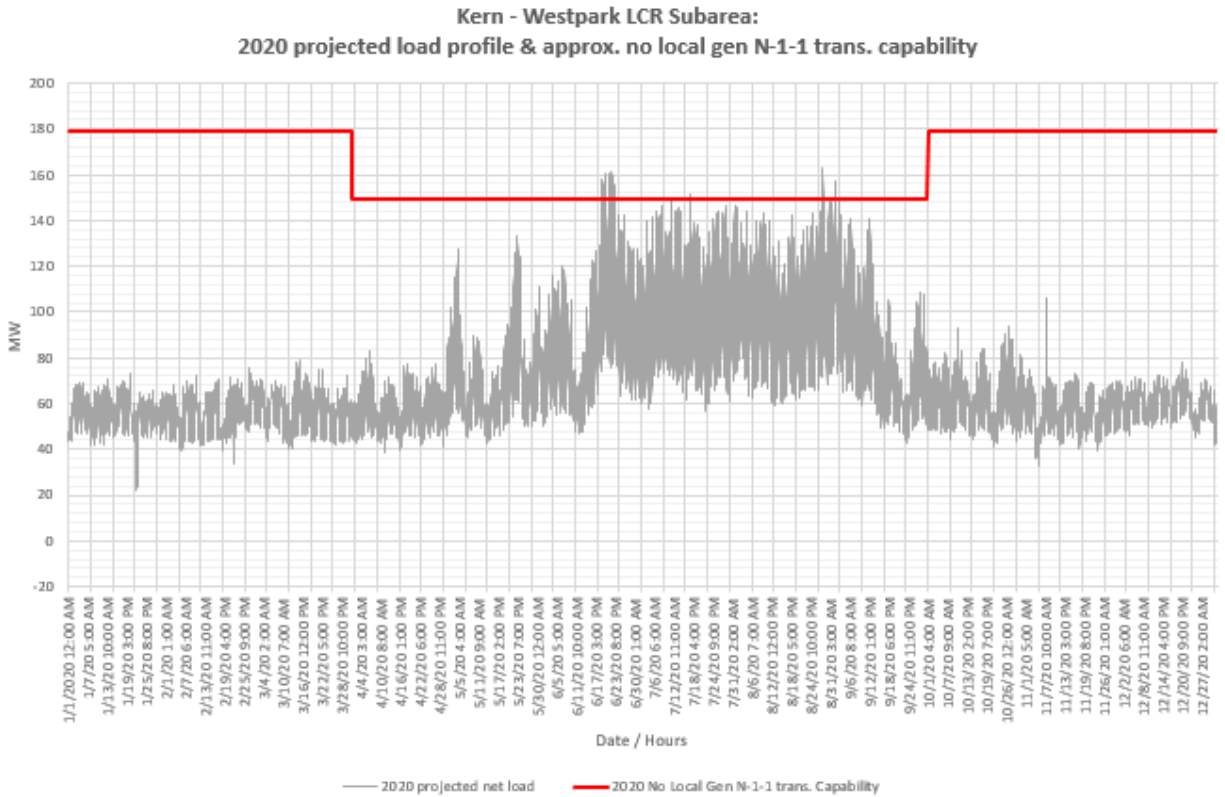

Figure 3.3-86 Westpark LCR Sub-area 2020 Forecast Hourly Profiles



3.3.7.3.4 Westpark LCR Sub-area Requirement

Table 3.3-61 identifies the sub-area LCR requirements. The LCR requirement for Category B (Single Contingency) and Category C (Multiple Contingency) are the same 60 MW including a 13 MW NQC and at peak deficiency.

Table 3.3-61 Westpark LCR Sub-area Requirements

Year	Limit	Category	Limiting Facility	Contingency	LCR (MW) (Deficiency)
2020	First Limit	B/C	Remaining Kern-West Park #1 or #2 115 kV	Kern-West Park #1 or #2 115 kV with PSE Bear out of service	60 (13)

3.3.7.3.5 Effectiveness factors:

All units within the Westpark Sub-area have the same effectiveness factor.

For most helpful procurement information please read procedure 2210Z Effectiveness Factors under 7110 (T-138Z) posted at: <http://www.caiso.com/Documents/2210Z.pdf>

3.3.7.4 Kern Oil Sub-area

Kern Oil is a Sub-area of the Kern LCR Area.

3.3.7.4.1 Kern Oil LCR Sub-area Diagram

Figure 3.3-87 Kern Oil LCR Sub-area

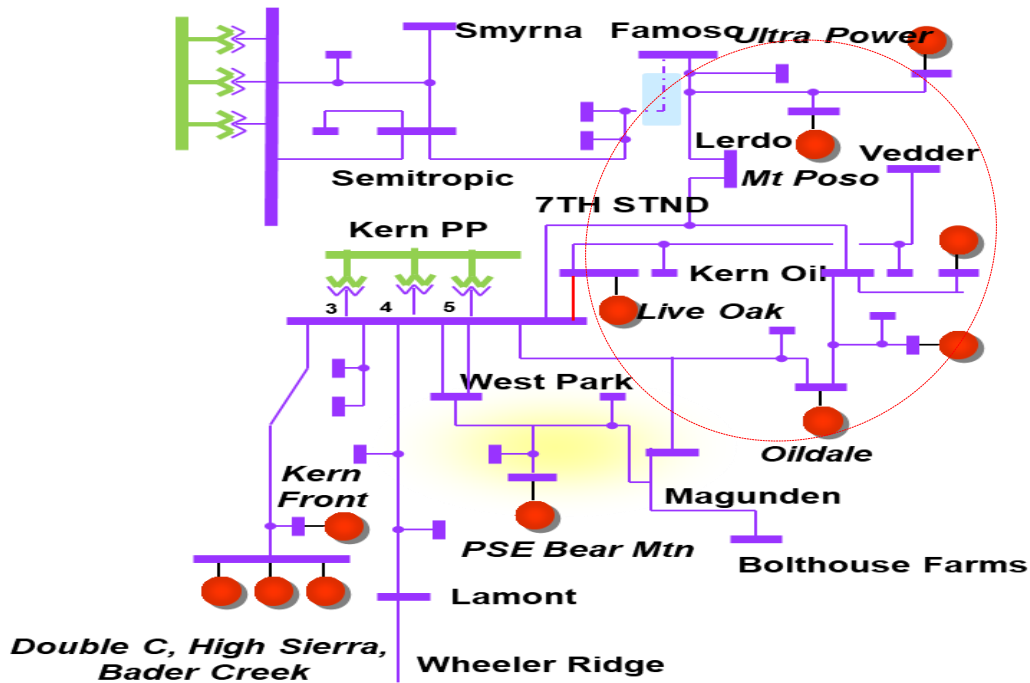

3.3.7.4.2 Kern Oil LCR Sub-area Load and Resources

Table 3.3-62 provides the forecast load and resources in Kern Oil LCR Sub-area in 2020. The list of generators within the LCR Sub-area are provided in Attachment A.

Table 3.3-62 Kern Oil LCR Sub-area 2020 Forecast Load and Resources

Load (MW)		Generation (MW)	NQC	At Peak
Gross Load	280	Market, Net Seller	103	103
AAEE	-4	MUNI	0	0
Behind the meter DG	0	QF	8	8
Net Load	276	Solar	11	0
Transmission Losses	2	Existing 20-minute Demand Response	0	0
Pumps	0	Mothballed	0	0
Load + Losses + Pumps	278	Total	122	111

3.3.7.4.3 Kern Oil LCR Sub-area Hourly Profiles

Figure 3.3-88 illustrates the forecast 2020 profile for the summer peak, winter peak and spring off-peak days for the Kern Oil LCR Sub-area with the Category C (Multiple Contingency) transmission capability without resources. Figure 3.3-89 illustrates the forecast 2020 hourly profile for Kern Oil LCR Sub-area with the Category C (Multiple Contingency) transmission capability without resources.

Figure 3.3-88 Kern Oil LCR Sub-area 2020 Peak Day Forecast Profiles

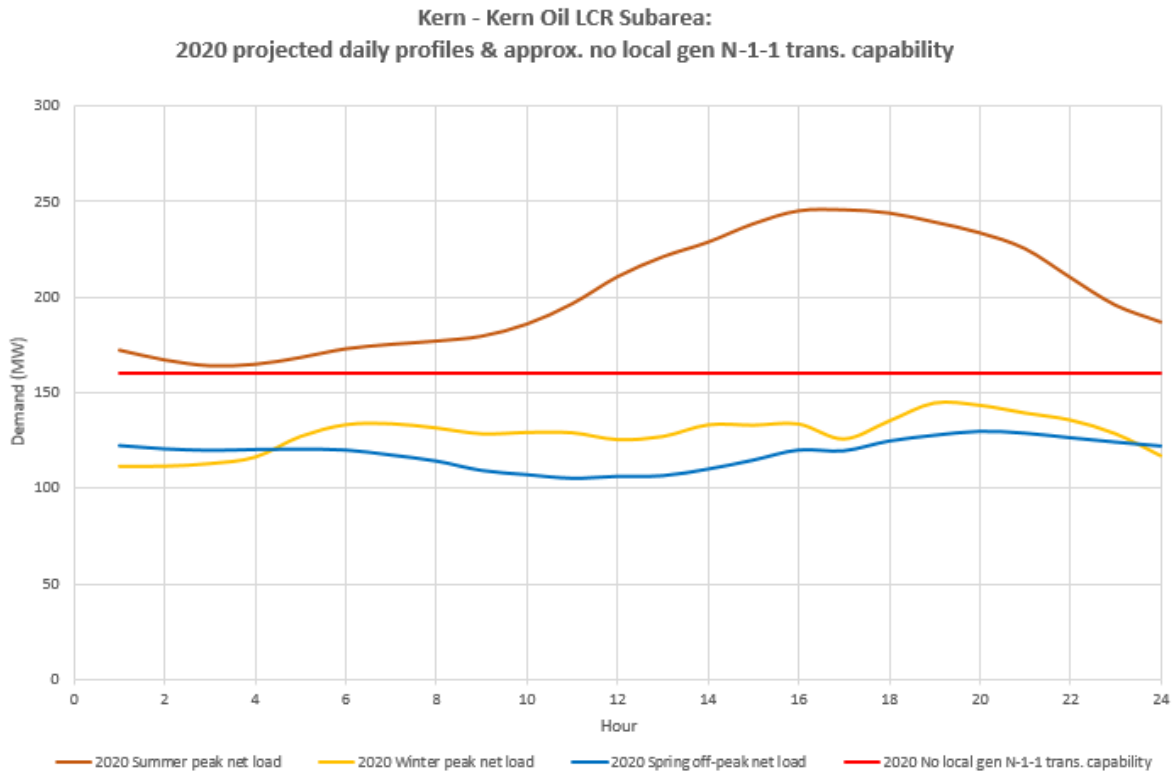
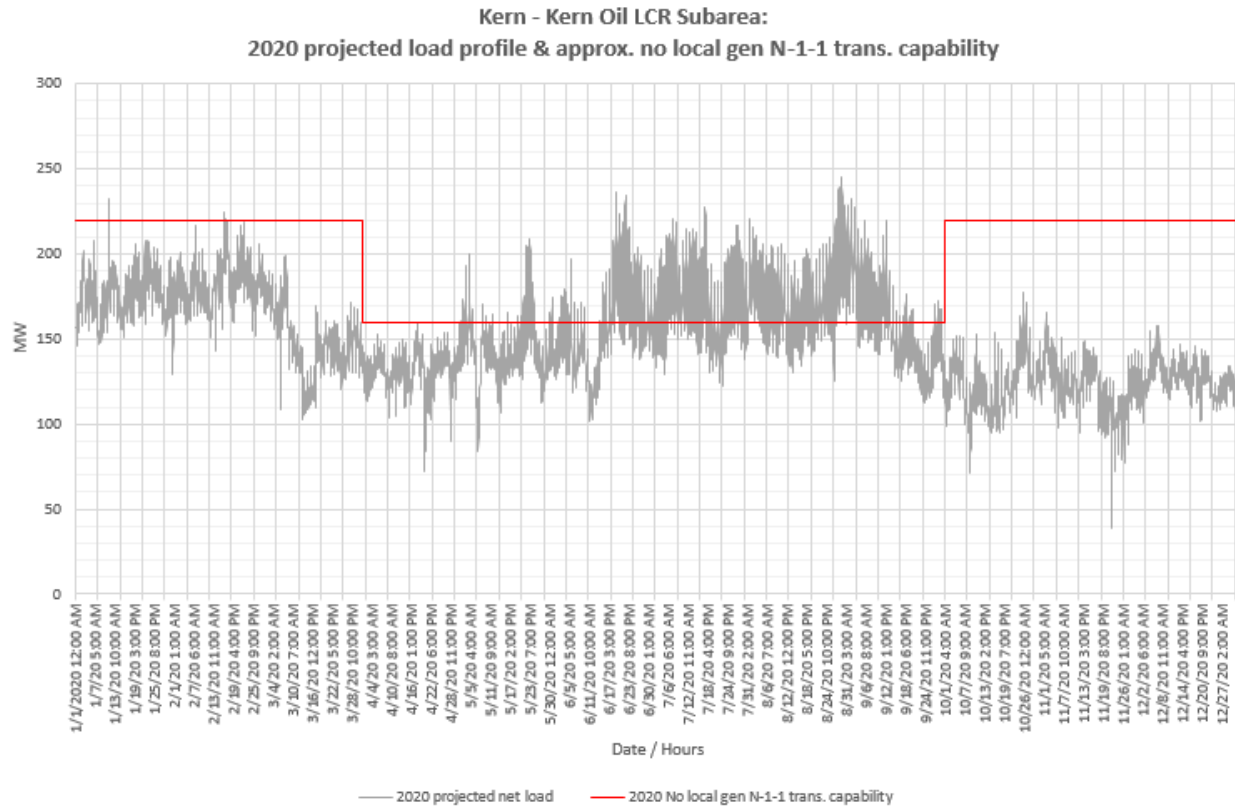

Figure 3.3-89 Kern Oil LCR Sub-area 2020 Forecast Hourly Profiles



3.3.7.4.4 Kern Oil LCR Sub-area Requirement

Table 3.3-63 identifies the sub-area LCR requirements. The LCR requirement for Category B (Single Contingency) and for Category C (Multiple Contingency) is 131 MW including a 9 MW NQC deficiency or 20 MW at peak deficiency.

Table 3.3-63 Kern Oil LCR Sub-area Requirements

Year	Limit	Category	Limiting Facility	Contingency	LCR (MW) (Deficiency)
2020	First limit	B	Kern PP-Magunden-Witco 115 kV Line (Kern PP-Kern Water section)	Kern PP-7 th Standard 115 kV with Mount Poso out of service	131 (9 NQC/ 20 Peak)
2020	First Limit	C	Kern PP-Magunden-Witco 115 kV Line (Kern PP-Kern Water section)	Kern-Live Oak 115 kV & Kern PP-7 th Standard 115 kV	131 (9 NQC/ 20 Peak)

3.3.7.4.5 Effectiveness factors:

All units within the Kern Oil Sub-area have the same effectiveness factor.

For most helpful procurement information please read procedure 2210Z Effectiveness Factors under 7110 (T-138Z) posted at: <http://www.caiso.com/Documents/2210Z.pdf>

3.3.7.5 South Kern PP Sub-area

South Kern PP is Sub-area of the Kern LCR Area.

3.3.7.5.1 South Kern PP LCR Sub-area Diagram

Figure 3.3-90 South Kern PP LCR Sub-area

3.3.7.5.2 South Kern PP LCR Sub-area Load and Resources

Refer to Table3.3-58 Kern Area Load and Resources table.

3.3.7.5.3 South Kern PP LCR Sub-area Hourly Profiles

Figure 3.3-91 illustrates the forecast 2020 profile for the summer peak, winter peak and spring off-peak days for the South Kern PP LCR Sub-area with the Category C (Multiple Contingency) transmission capability without resources. Figure 3.3-92 illustrates the forecast 2020 hourly profile for South Kern PP LCR Sub-area with the Category C (Multiple Contingency) transmission capability without resources.

Figure 3.3-91 South Kern PP LCR Sub-area 2020 Peak Day Forecast Profiles

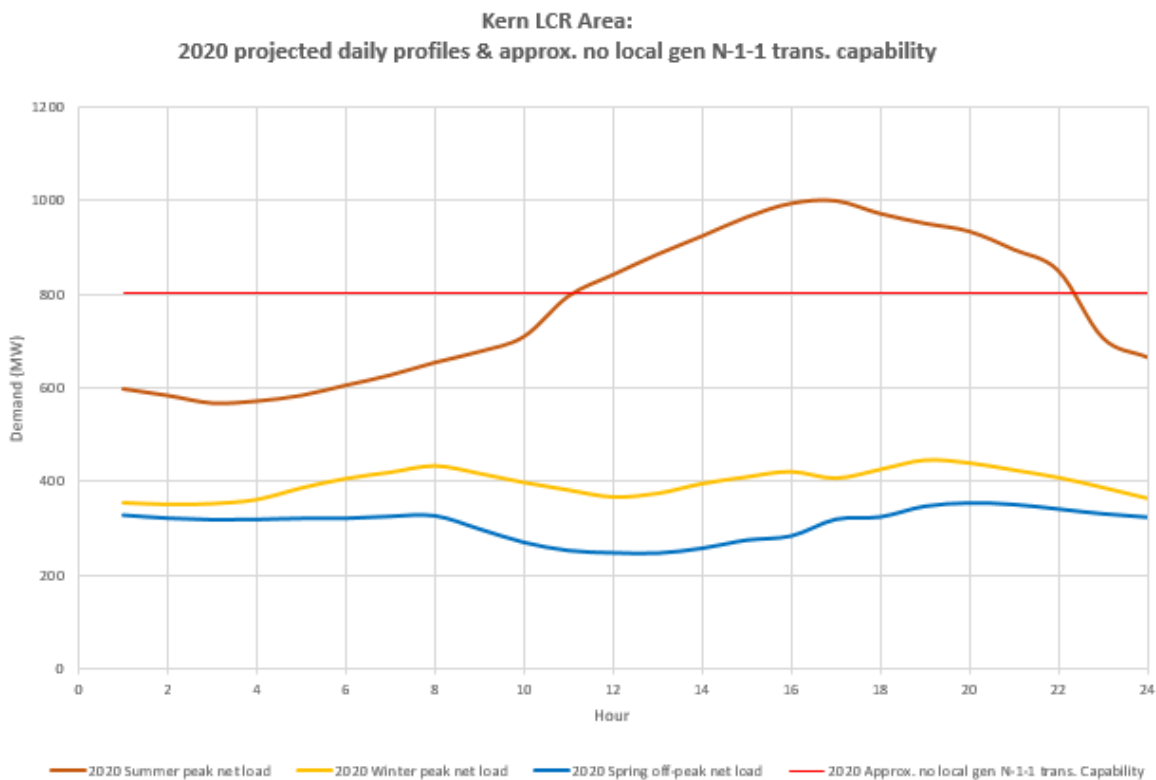
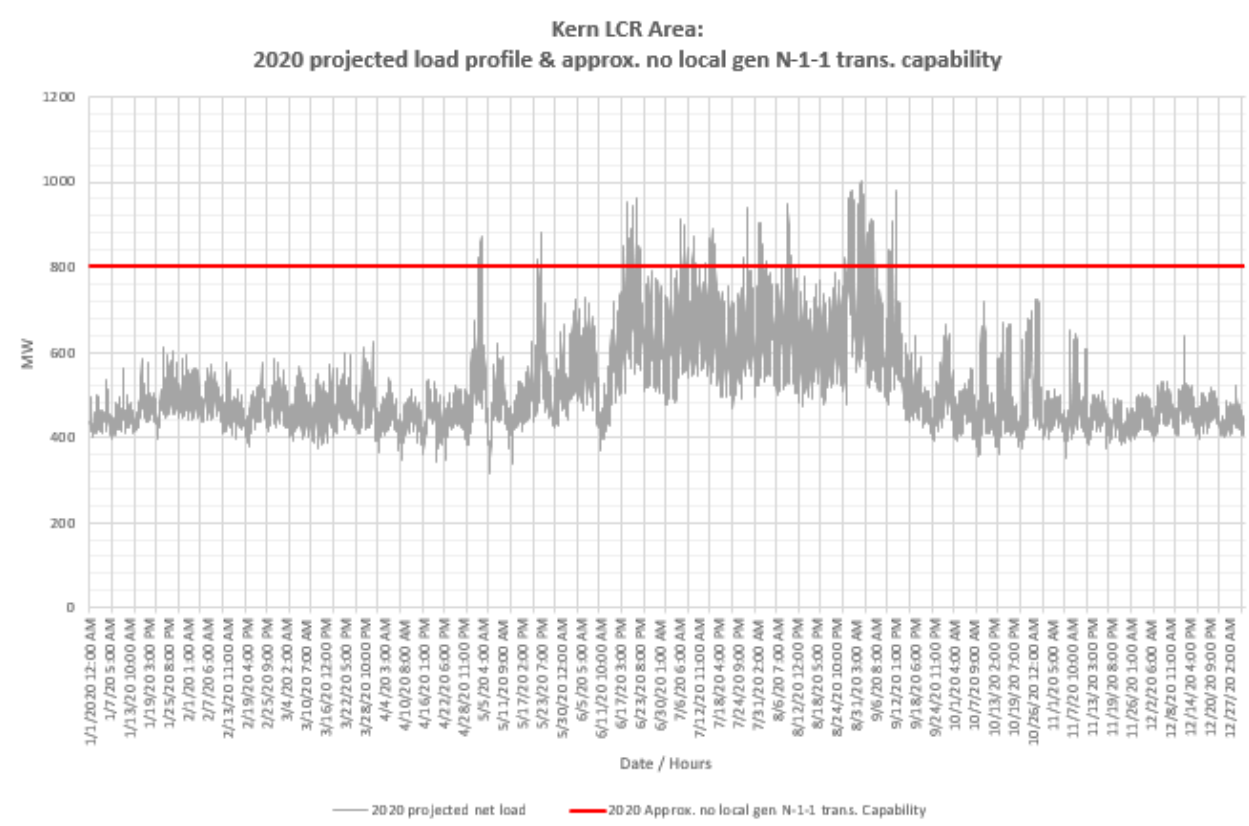

Figure 3.3-92 South Kern PP LCR Sub-area 2020 Forecast Hourly Profiles



3.3.7.5.4 South Kern PP LCR Sub-area Requirement

Table 3.3-64 identifies the sub-area LCR requirements. The LCR requirement for Category B (Single Contingency) is 136 MW and for Category C (Multiple Contingency) is 592 MW including 127 MW of NQC deficiency or 230 MW at peak deficiency.

Table 3.3-64 South Kern PP LCR Sub-area Requirements

Year	Limit	Category	Limiting Facility	Contingency	LCR (MW) (Deficiency)
2020	First limit	B	Midway-Kern PP #2 230 kV	Midway-Kern PP #3 230 kV with High Sierra out of service	136
2020	First Limit	C	Midway-Kern PP #4 230 kV	Midway-Kern PP #2 & #3 230 kV	592 (127 NQC/ 230 Peak)

3.3.7.5.5 Effectiveness factors:

All units within the South Kern PP Sub-area have the same effectiveness factor.

For most helpful procurement information please read procedure 2210Z Effectiveness Factors under 7450 (New) posted at: <http://www.caiso.com/Documents/2210Z.pdf>

3.3.7.6 Kern Area Overall Requirements

3.3.7.6.1 Kern LCR Area Overall Requirement

Table 3.3-65 identifies the limiting facility and contingency that establishes the Kern Area 2020 LCR requirements. The LCR requirement for Category B (Single Contingency) is 191 MW including 22 MW of NQC deficiency or 33 MW of at peak deficiency and for Category C (Multiple Contingency) the LCR requirement is 592 MW including a 127 MW deficiency.

Table 3.3-65 Kern Overall LCR Sub-area Requirements

Year	Limit	Category	Limiting Facility	Contingency	LCR (MW) (Deficiency)
2020	First limit	B	Aggregate of Sub-areas.		191 (22 NQC/ 33 Peak)
2020	First Limit	C	Aggregate of Sub-areas.		592 (127 NQC/ 230 Peak)

3.3.7.6.2 Kern Overall LCR Area Hourly Profile

Refer to South Kern PP LCR area profiles.

3.3.7.6.3 Changes compared to 2019 requirements

Compared with 2019 the load forecast increased by 81 MW and the LCR requirement has increased by 114 MW. The capacity needed from existing resources has decrease by7 MW due to decrease in NQC values.

3.3.8 Big Creek/Ventura Area

3.3.8.1 Area Definition:

The transmission tie lines into the Big Creek/Ventura Area are:

- Antelope #1 500/230 kV Transformer
- Antelope #2 500/230 kV Transformer
- Sylmar - Pardee 230 kV #1 and #2 Lines
- Vincent - Pardee 230 kV #2 Line
- Vincent - Santa Clara 230 kV Line

The substations that delineate the Big Creek/Ventura Area are:

- Antelope 500 kV is out Antelope 230 kV is in

- Antelope 500 kV is out Antelope 230 kV is in
- Sylmar is out Pardee is in
- Vincent is out Pardee is in
- Vincent is out Santa Clara is in

3.3.8.1.1 Big Creek/Ventura LCR Area Diagram

Figure 3.3-93 Big Creek/Ventura LCR Area

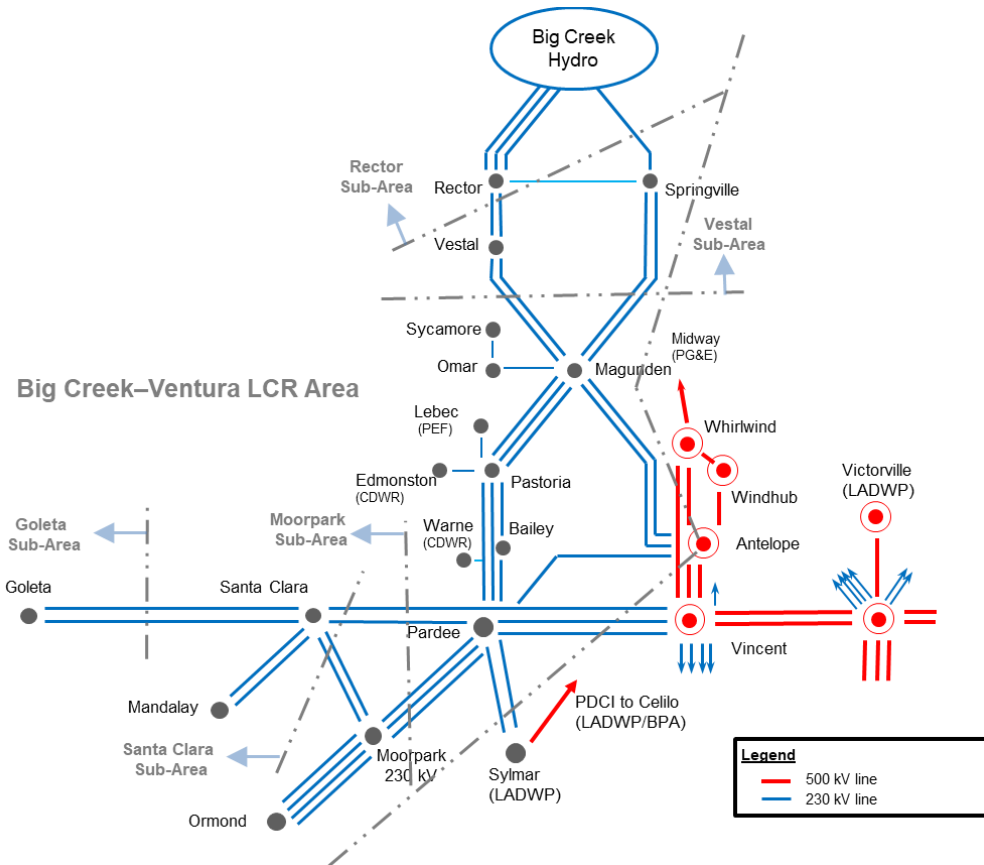

3.3.8.1.2 Big Creek/Ventura LCR Area Load and Resources

Table 3.3-66 provides the forecast load and resources in the Big Creek/Ventura LCR Area in 2020. The list of generators within the LCR area are provided in Attachment A and does not include new LTPP preferred resources as well as existing 20-minute DR.

In year 2020 the estimated time of local area peak is 5:00 PM.

At the local area peak time the estimated, behind the meter, solar output is 55.0%.

At the local area peak time the estimated, ISO metered, solar output is about 70.00%, therefore solar resources are dispatched at NQC.

If required, all non-solar technology type resources are dispatched at NQC.

Table 3.3-66 Big Creek/Ventura LCR Area 2020 Forecast Load and Resources

Load (MW)		Generation (MW)	NQC	At Peak
Gross Load	4882	Market, Net Seller, Solar	4594	4594
AAEE	-47	MUNI	342	342
Behind the meter DG	-323	QF	63	63
Net Load	4512	LTPP Preferred Resources	0	0
Transmission Losses	75	Existing 20-minute Demand Response	100	100
Pumps	369	Mothballed	0	0
Load + Losses + Pumps	4956	Total	5099	5099

3.3.8.1.3 Approved transmission projects modeled:

- Big Creek Corridor Rating Increase Project (ISD - 04/01/2020).

3.3.8.2 Rector Sub-area

LCR need is satisfied by the need in the larger Vestal sub-area.

3.3.8.3 Vestal Sub-area

Vestal is a Sub-area of the Big Creek/Ventura LCR Area.

3.3.8.3.1 Vestal LCR Sub-area Diagram

Figure 3.3-94 Vestal LCR Sub-area

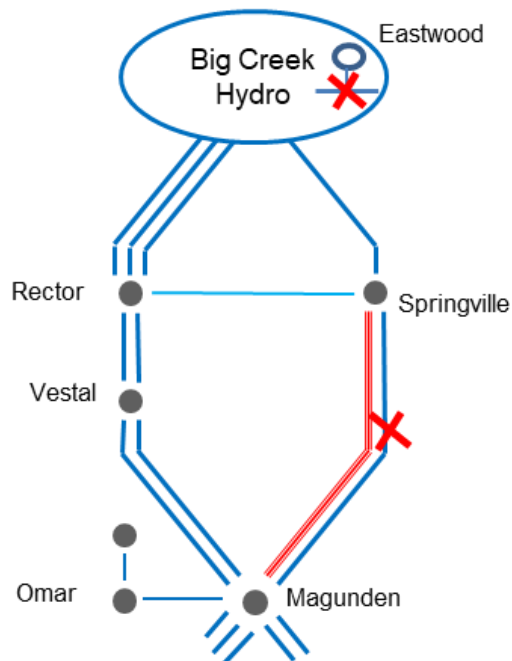

3.3.8.3.2 Vestal LCR Sub-area Load and Resources

Table 3.3-67 provides the forecast load and resources in Vestal LCR Sub-area in 2020. The list of generators within the LCR Sub-area are provided in Attachment A.

Table 3.3-67 Vestal LCR Sub-area 2020 Forecast Load and Resources

Load (MW)		Generation (MW)	NQC	At Peak
Gross Load	N/A	Market, Net Seller, Solar	1117	1117
AAEE	N/A	MUNI	0	0
Behind the meter DG	N/A	QF	15	15
Net Load	1315	LTPP Preferred Resources	0	0
Transmission Losses	22	Existing 20-minute Demand Response	57	57
Pumps	0	Mothballed	0	0
Load + Losses + Pumps	1337	Total	1189	1189

3.3.8.3.3 Vestal LCR Sub-area Hourly Profiles

Figure 3.3-95 illustrates the forecast 2020 profile for the summer peak day in the Vestal LCR Sub-area.

Figure 3.3-95 Vestal LCR Sub-area 2020 Peak Day Forecast Profiles

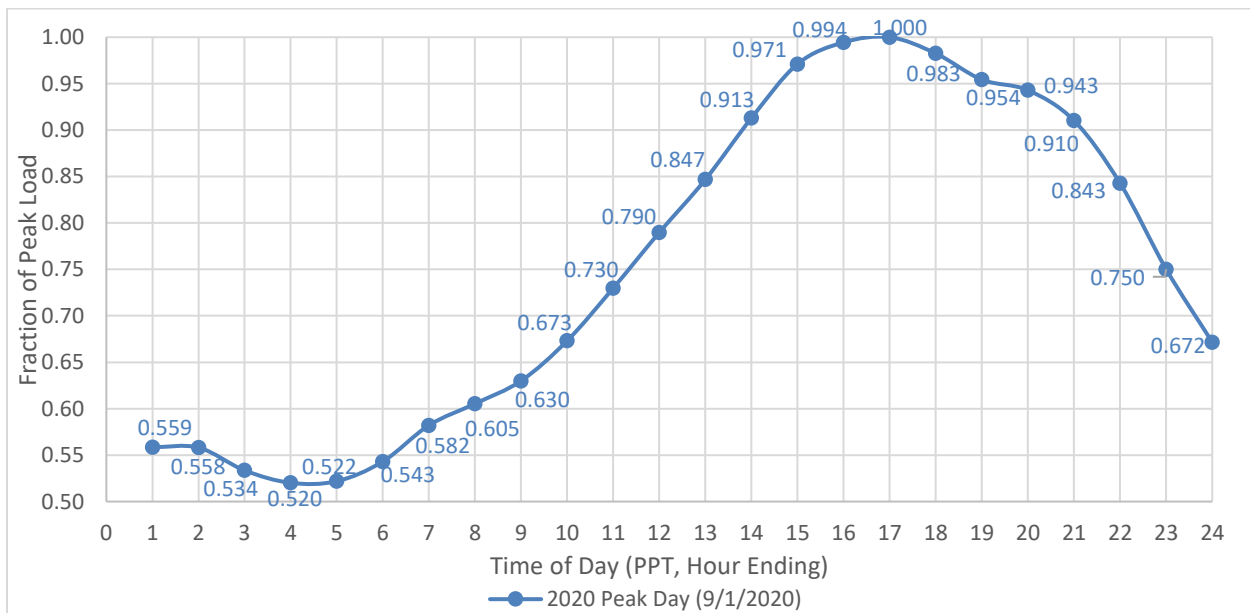

3.3.8.3.4 Vestal LCR Sub-area Requirement

Table 3.3-68 identifies the sub-area LCR requirements. The Category B (Single Contingency) LCR requirement and the LCR requirement for Category C (Multiple Contingency) are 425 MW.

Table 3.3-68 Vestal LCR Sub-area Requirements

Year	Limit	Category	Limiting Facility	Contingency	LCR (MW) (Deficiency)
2020	First Limit	B/C	Magunden-Springville #2 230 kV	Magunden-Springville #1 230 kV with Eastwood out of service	425

3.3.8.3.5 Effectiveness factors:

For helpful procurement information please read procedure 2210Z Effectiveness Factors under 7500 posted at: <http://www.caiso.com/Documents/2210Z.pdf>

3.3.8.4 Goleta Sub-area

LCR need is satisfied by the need in the larger Santa Clara sub-area.

3.3.8.5 Santa Clara Sub-area

Santa Clara is a Sub-area of the Big Creek/Ventura LCR Area.

3.3.8.5.1 Santa Clara LCR Sub-area Diagram

Figure 3.3-96 Santa Clara LCR Sub-area

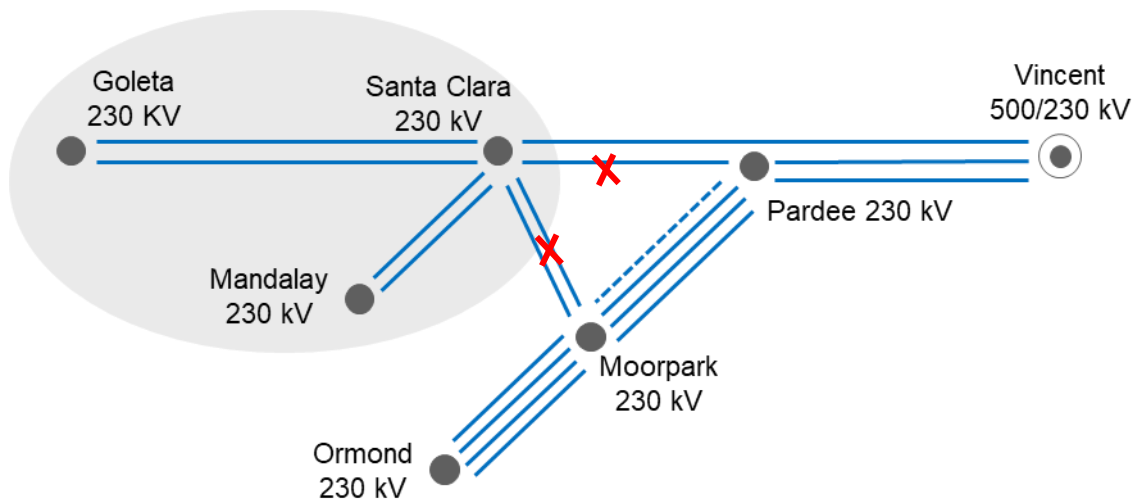

3.3.8.5.2 Santa Clara LCR Sub-area Load and Resources

Table 3.3-69 provides the forecast load and resources in Santa Clara LCR Sub-area in 2020. The list of generators within the LCR Sub-area are provided in Attachment A.

Table 3.3-69 Santa Clara LCR Sub-area 2020 Forecast Load and Resources

Load (MW)		Generation (MW)	NQC	At Peak
Gross Load	N/A	Market, Net Seller, Solar	202	202
AAEE	N/A	MUNI	0	0
Behind the meter DG	N/A	QF	42	42
Net Load	898	LTPP Preferred Resources	0	0
Transmission Losses	3	Existing 20-minute Demand Response	9	9
Pumps	0	Mothballed	0	0
Load + Losses + Pumps	901	Total	253	253

3.3.8.5.3 Santa Clara LCR Sub-area Hourly Profiles

Figure 3.3-97 illustrates the forecast 2020 profile for the summer peak day in the Santa Clara LCR Sub-area.

Figure 3.3-97 Santa Clara LCR Sub-area 2020 Peak Day Forecast Profiles

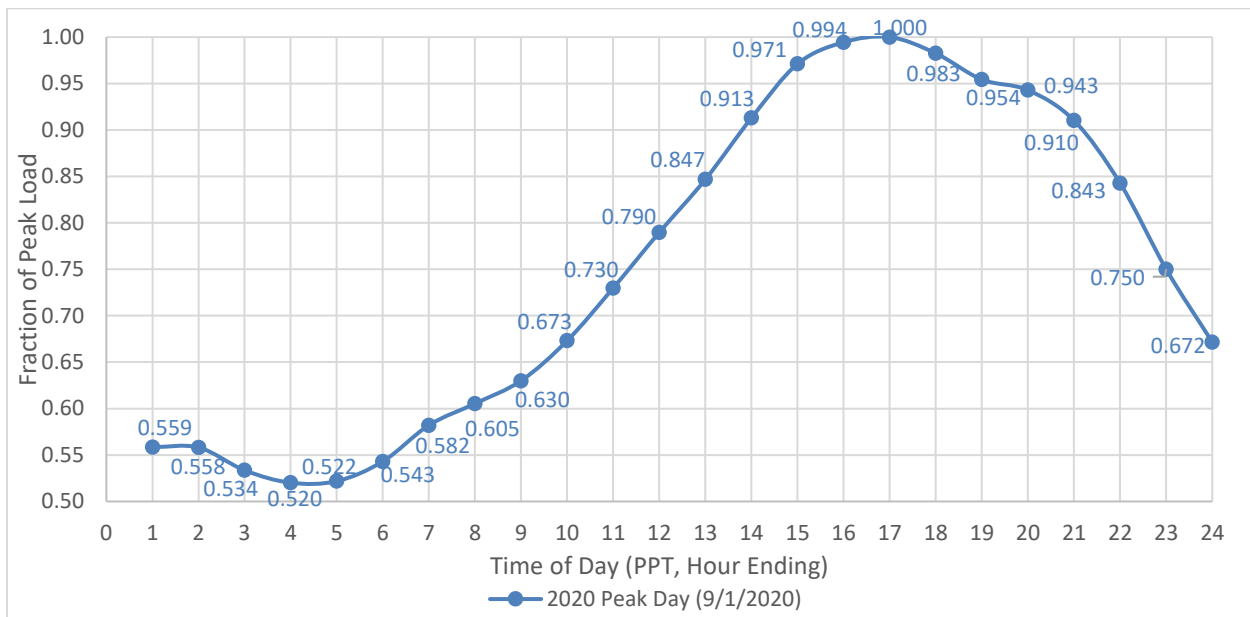

3.3.8.5.4 Santa Clara LCR Sub-area Requirement

Table 3.3-70 identifies the sub-area requirements. There is no Category B (Single Contingency) LCR requirement and the LCR requirement for Category C (Multiple Contingency) is 288 MW including 35 MW of deficiency.

Table 3.3-70 Santa Clara LCR Sub-area Requirements

Year	Limit	Category	Limiting Facility	Contingency	LCR (MW) (Deficiency)
2020	First Limit	B	None	None	0
2020	First Limit	C	Voltage collapse	Pardee - Santa Clara 230 kV followed by Moorpark - Santa Clara #1 & #2 230 kV	288 (35)

3.3.8.5.5 Effectiveness factors:

For helpful procurement information please read procedure 2210Z Effectiveness Factors under 7500 posted at: <http://www.caiso.com/Documents/2210Z.pdf>

3.3.8.6 Moorpark Sub-area

Moorpark is a Sub-area of the Big Creek/Ventura LCR Area.

3.3.8.6.1 Moorpark LCR Sub-area Diagram

Figure 3.3-98 Moorpark LCR Sub-area

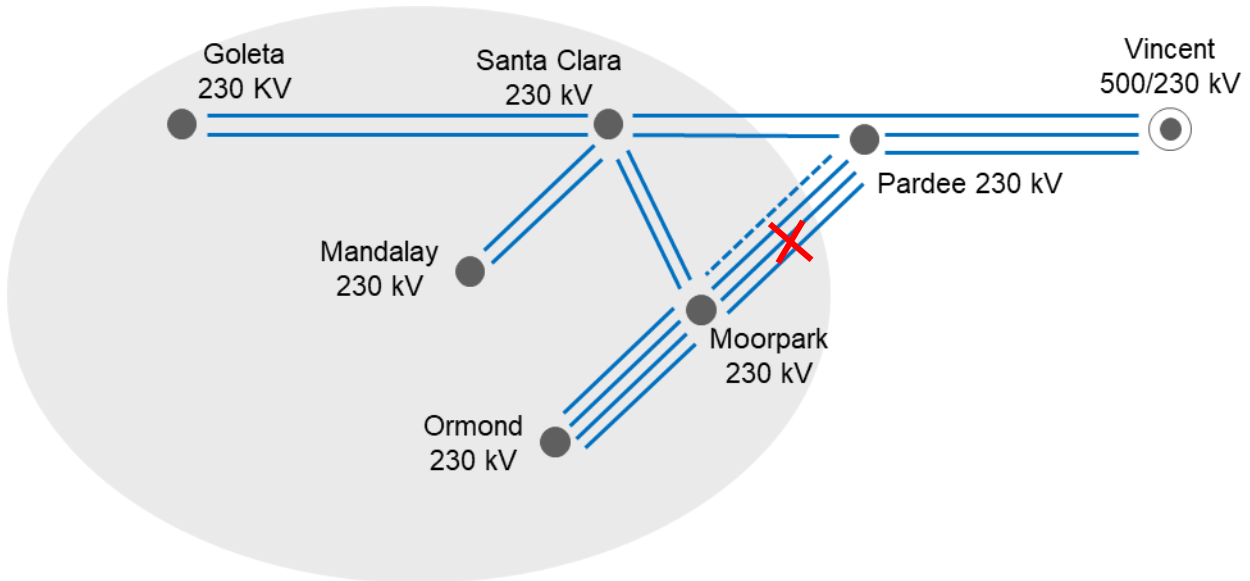

3.3.8.6.2 Moorpark LCR Sub-area Load and Resources

Table 3.3-71 provides the forecast load and resources in Moorpark LCR Sub-area in 2020. The list of generators within the LCR Sub-area are provided in Attachment A.

Table 3.3-71 Moorpark LCR Sub-area 2020 Forecast Load and Resources

Load (MW)	Generation (MW)	NQC	At Peak

Gross Load	N/A	Market, Net Seller, Solar	1724	1724
AAEE	N/A	MUNI	0	0
Behind the meter DG	N/A	QF	42	42
Net Load	1780	LTPP Preferred Resources	0	0
Transmission Losses	15	Existing 20-minute Demand Response	20	20
Pumps	0	Mothballed	0	0
Load + Losses + Pumps	1795	Total	1786	1786

3.3.8.6.3 Moorpark LCR Sub-area Hourly Profiles

Figure 3.3-99 illustrates the forecast 2020 profile for the summer peak day in the Moorpark LCR Sub-area.

Figure 3.3-99 Moorpark LCR Sub-area 2020 Peak Day Forecast Profiles

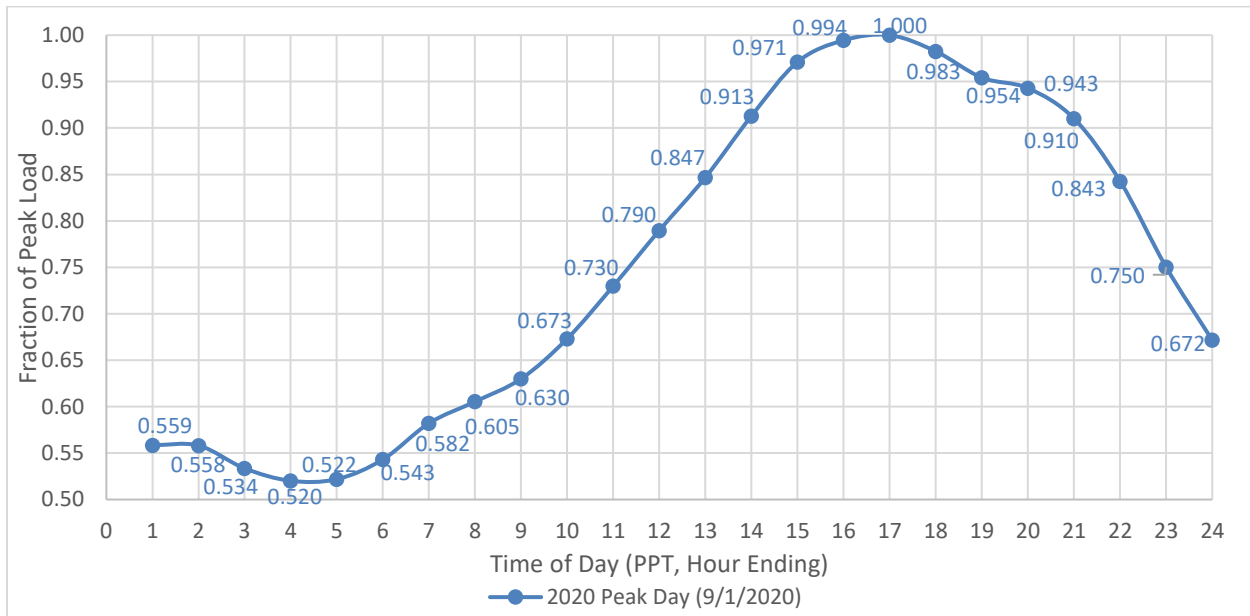

3.3.8.6.4 Moorpark LCR Sub-area Requirement

Table 3.3-72 identifies the sub-area requirements. There is no Category B (Single Contingency) LCR requirement and the LCR requirement for Category C (Multiple Contingency) is 514 MW.

Table 3.3-72 Moorpark LCR Sub-area Requirements

Year	Limit	Category	Limiting Facility	Contingency	LCR (MW) (Deficiency)

2020	First Limit	B	None	None	0
2020	First Limit	C	Voltage collapse	Pardee – Moorpark #3 230 kV followed by Pardee - Moorpark #1 & #2 230 kV	514

3.3.8.6.5 Effectiveness factors:

For helpful procurement information please read procedure 2210Z Effectiveness Factors under 7500 posted at: <http://www.caiso.com/Documents/2210Z.pdf>

3.3.8.7 Big Creek/Ventura Overall

3.3.8.7.1 Big Creek/Ventura LCR Sub-area Hourly Profiles

Figure 3.3-100 illustrates the forecast 2020 profile for the summer peak day in the Big Creek/Ventura LCR area.

Figure 3.3-100 Big Creek/Ventura LCR area 2020 Peak Day Forecast Profiles

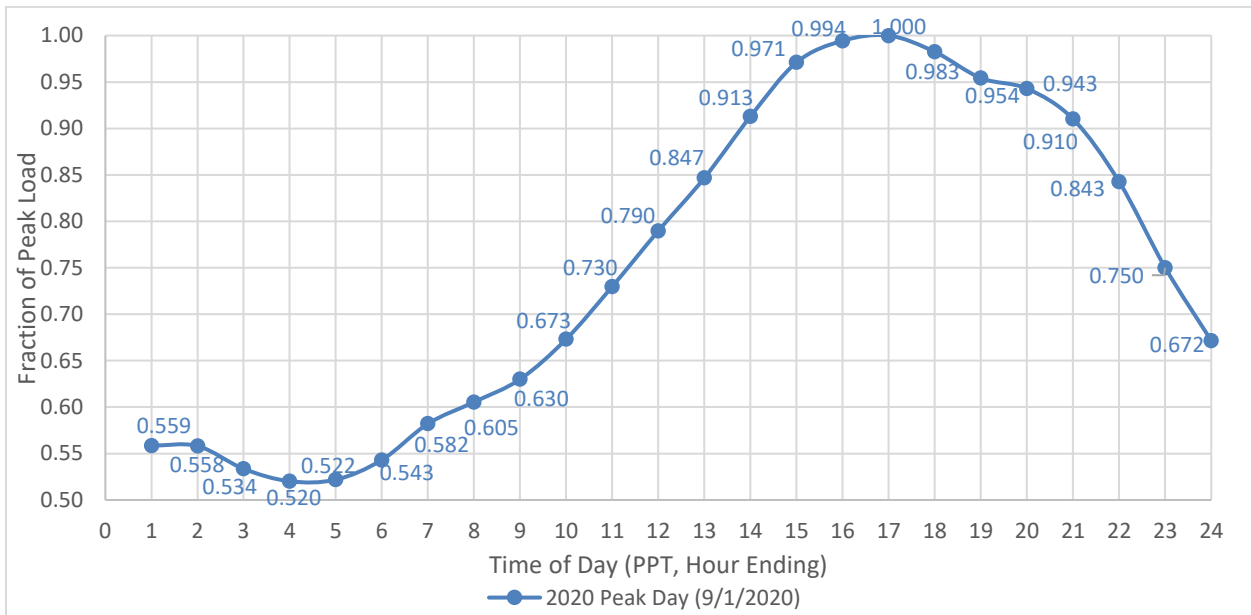

3.3.8.7.2 Big Creek/Ventura LCR area Requirement

Table 3.3-73 identifies the area LCR requirements. The LCR requirement for Category B (Single Contingency) is 2154 MW and for Category C (Multiple Contingency) is 2410 MW.

Table 3.3-73 Big Creek/Ventura LCR area Requirements

Year	Limit	Category	Limiting Facility	Contingency	LCR (MW) (Deficiency)
2020	First Limit	B	Remaining Sylmar - Pardee 230 kV	One of the Sylmar - Pardee 230 kV lines with Ormond Beach #2 out of service	2154
2020	First Limit	C	Remaining Sylmar - Pardee 230 kV	Lugo - Victorville 500 kV line followed by one of the Sylmar - Pardee #1 or #2 230 kV lines	2410
2020	Sensitivity ¹²	C	Remaining Sylmar - Pardee 230 kV	Lugo - Victorville 500 kV line followed by one of the Sylmar - Pardee #1 or #2 230 kV lines	3500

3.3.8.7.3 Effectiveness factors:

For helpful procurement information please read procedure 2210Z Effectiveness Factors under 7680 (T-130Z), 7510 (T-163Z), 7550 (T-159Z) and 8610 (T-131Z) posted at: <http://www.caiso.com/Documents/2210Z.pdf>

3.3.8.7.4 Changes compared to 2019 LCT study

Compared with the results for 2019, the load forecast is down by 206 MW and the LCR has decreased by 204 MW due to the decrease in the load forecast.

3.3.9 LA Basin Area

3.3.9.1 Area Definition:

The transmission tie lines into the LA Basin Area are:

- San Onofre - San Luis Rey #1, #2, and #3 230 kV Lines
- San Onofre - Talega #1 & #2 230 kV Lines
- Lugo - Mira Loma #2 & #3 500 kV Lines
- Lugo - Rancho Vista #1 500 kV Line
- Vincent – Mira Loma 500 kV Line
- Sylmar - Eagle Rock 230 kV Line
- Sylmar - Gould 230 kV Line

¹² The sensitivity assessment was performed in response to SCE's request to determine the impact on LCR of a long-term planned outage of the Eldorado-Lugo 500 kV line if the outage is scheduled during the summer peak load period.

- Vincent - Mesa #1 & #2 230 kV Lines
- Vincent - Rio Hondo #1 & #2 230 kV Lines
- Devers - Red Bluff 500 kV #1 and #2 Lines
- Mirage – Coachella Valley # 1 230 kV Line
- Mirage - Ramon # 1 230 kV Line
- Mirage - Julian Hinds 230 kV Line

The substations that delineate the LA Basin Area are:

- San Onofre is in San Luis Rey is out
- San Onofre is in Talega is out
- Mira Loma is in Lugo is out
- Rancho Vista is in Lugo is out
- Eagle Rock is in Sylmar is out
- Gould is in Sylmar is out
- Mira Loma is in Vincent is out
- Mesa is in Vincent is out
- Rio Hondo is in Vincent is out
- Devers is in Red Bluff is out
- Mirage is in Coachella Valley is out
- Mirage is in Ramon is out
- Mirage is in Julian Hinds is out

3.3.9.1.1 LA Basin LCR Area Diagram

Figure 3.3-101 LA Basin LCR Area

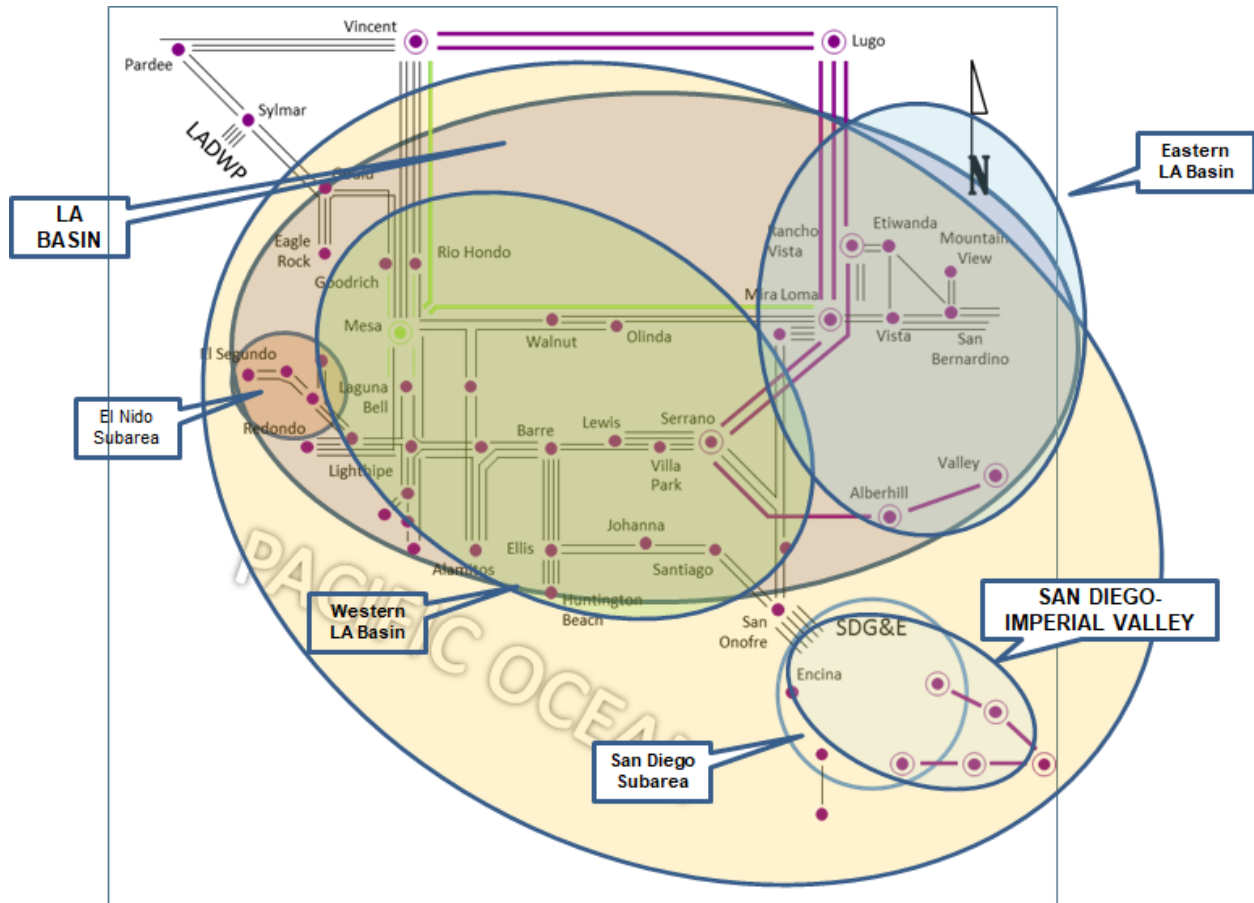

3.3.9.1.2 LA Basin LCR Area Load and Resources

Table 3.3-74 provides the forecast load and resources in the LA Basin LCR Area in 2020. The list of generators within the LCR area are provided in Attachment A and does not include new LTPP preferred resources as well as existing 20-minute DR.

In year 2020 the estimated time of local area peak is 5:00 PM (PDT) based on the CEC hourly forecast for the 2018-2030 California Energy Demand Updated (CEDU) Forecast.

At the local area peak time the estimated, behind the meter, solar output is 26%.

At the local area peak time the estimated, ISO metered, solar output is 33.4%.

If required, all non-solar technology type resources are dispatched at NQC.

Table 3.3-74 LA Basin LCR Area 2020 Forecast Load and Resources

Load (MW)		Generation (MW)	NQC	At Peak
Gross Load	20684	Market, Net Seller, Wind, Battery, Solar	8216	8216
AAEE + AAPV	-277	MUNI	1110	1110

Behind the meter DG	-1450	QF	234	234
Net Load	18957	LTPP Preferred Resources	248	248
Transmission Losses	284	Existing 20-minute Demand Response	295	295
Pumps	20	Mothballed	335	0
Load + Losses + Pumps	19261	Total	10439	10104

The total load plus losses and pump loads above is for the LA Basin geographic area (same area from the CEC’s demand forecast for the LA Basin in the LSE/BA Table). However, the electrically defined LA Basin LCR area does not include Saugus substation load, which is 725 MW. When this is subtracted to the geographically defined LA Basin load, the total load plus losses and pump load for the electrically defined LA Basin is estimated to be 18,536 MW.

3.3.9.1.3 Approved transmission projects modeled:

- Hassayampa – North Gila #2 500 kV Line (APS)
- Alamitos repowering (640 MW)
- Huntington Beach repowering (644 MW)
- Stanton Energy Reliability Center (98 MW)
- Retirement of about 830 MW of once-through-cooled generation at Alamitos generating facility, 480 MW at Redondo Beach generating facility and 215 MW at Huntington Beach generating facility.

3.3.9.2 El Nido Sub-area

El Nido is a Sub-area of the LA Basin LCR Area.

3.3.9.2.1 El Nido LCR Sub-area Diagram

Please refer to Figure 3.3-101 above.

3.3.9.2.2 El Nido LCR Sub-area Load and Resources

Table 3.3-75 provides the forecast load and resources in El Nido LCR Sub-area in 2020. The list of generators within the LCR Sub-area are provided in Attachment A.

Table 3.3-75 El Nido LCR Sub-area 2020 Forecast Load and Resources

Load (MW)		Generation (MW)	NQC	At Peak
Gross Load	1003	Market, Net Seller	536	536
AAEE	-13	MUNI	0	0

Behind the meter DG	-31	QF	0	0
Net Load	959	LTPP Preferred Resources	20	20
Transmission Losses	2	Existing 20-minute Demand Response	7	7
Pumps	0	Mothballed	0	0
Load + Losses + Pumps	961	Total	563	563

3.3.9.2.3 El Nido LCR Sub-area Hourly Profiles

Figure 3.3-102 illustrates the forecast 2020 profile for the summer peak day in the El Nido LCR Sub-area.

Figure 3.3-102 El Nido LCR Sub-area 2020 Peak Day Forecast Profiles

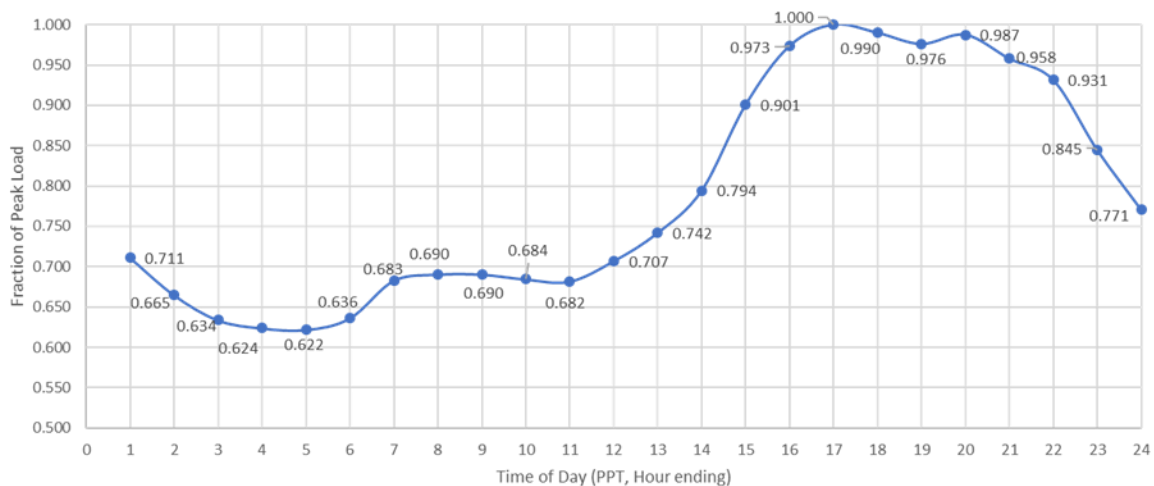

3.3.9.2.4 El Nido LCR Sub-area Requirement

Table 3.3-76 identifies the sub-area requirements. There is no Category B (Single Contingency) LCR requirement and the LCR requirement for Category C (Multiple Contingency) is 365 MW.

Table 3.3-76 El Nido LCR Sub-area Requirements

Year	Limit	Category	Limiting Facility	Contingency	LCR (MW) (Deficiency)
2020	First Limit	B	None	None	0
2020	First Limit	C	La Fresa-La Cienega 230 kV	La Fresa – El Nido #3 & #4 230 kV	365

3.3.9.2.5 Effectiveness factors:

All units within the El Nido Sub-area have the same effectiveness factor.

For most helpful procurement information please read procedure 2210Z Effectiveness Factors under 7630 (G-219Z) posted at: <http://www.caiso.com/Documents/2210Z.pdf>

3.3.9.3 Western LA Basin Sub-area

Western LA Basin is a sub-area of the LA Basin LCR Area.

3.3.9.3.1 Western LA Basin LCR Sub-area Diagram

Please refer to Figure 3.3-101 above.

3.3.9.3.2 Western LA Basin LCR Sub-area Load and Resources

Table 3.3-77 provides the forecast load and resources in Western LA Basin LCR Sub-area in 2020. The list of generators within the LCR Sub-area are provided in Attachment A.

Table 3.3-77 Western LA Basin Sub-area 2020 Forecast Load and Resources

Load (MW)		Generation (MW)	NQC	At Peak
Gross Load	11695	Market, Net Seller, Battery, Solar	5511	5511
AAEE	-135	MUNI	582	582
Behind the meter DG	-464	QF	57	57
Net Load	11096	LTPP Preferred Resources	248	248
Transmission Losses	166	Existing 20-minute Demand Response	154	154
Pumps	0	Mothballed	0	0
Load + Losses + Pumps	11262	Total	6552	6552

3.3.9.3.3 Western LA Basin LCR Sub-area Hourly Profiles

Figure 3.3-103 illustrates the forecast 2020 profile for the summer peak day in the Western LA Basin LCR Sub-area.

Figure 3.3-103 Western LA Basin LCR Sub-area 2020 Peak Day Forecast Profiles

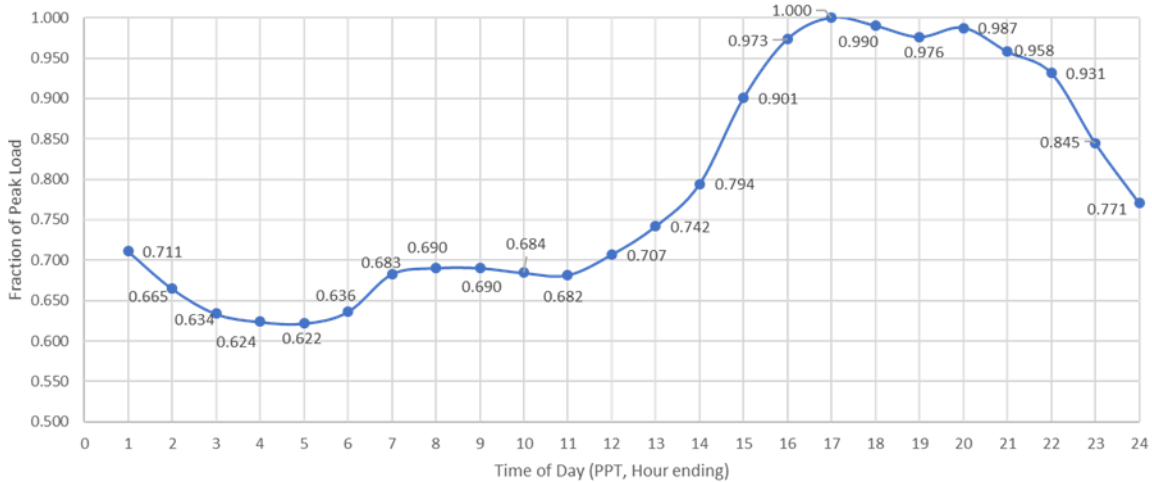

3.3.9.3.4 Western LA Basin LCR Sub-area Requirement

Table 3.3-78 identifies the Western LA Basin 2020 LCR Sub-area requirements. The Category B (Single Contingency) LCR requirement and the LCR requirement for Category C (Multiple Contingency) are the same 3,706 MW.

Table 3.3-78 Western LA Basin LCR Sub-area Requirements

Year	Limit	Category	Limiting Facility	Contingency	LCR (MW) (Deficiency)
2020	First Limit	B/C	Barre-Lewis 230 kV line	Barre-Villa Park 230 kV line with Huntington Beach CC out of service	3706

3.3.9.3.5 Effectiveness factors:

See Attachment B - Table titled [LA Basin](#).

For other helpful procurement information please read procedure 2210Z Effectiveness Factors under 7630 (G-219Z) posted at: <http://www.caiso.com/Documents/2210Z.pdf>

There are other combinations of contingencies in the area that could overload a significant number of 230 kV lines in this sub-area have less LCR need. As such, anyone of them (combination of contingencies) could become binding for any given set of procured resources. As a result, these effectiveness factors may not be the best indicator towards informed procurement.

3.3.9.4 West of Devers Sub-area

West of Devers is a Sub-area of the LA Basin LCR Area. The 2019 LCT study identified that the West of Devers Sub-area need is satisfied by the need in the larger Eastern LA Basin sub-area.

3.3.9.5 Valley-Devers Sub-area

Valley-Devers is a Sub-area of the LA Basin LCR Area. The 2019 LCT study identified that the Valley-Devers Sub-area need is satisfied by the need in the larger Eastern LA Basin sub-area.

3.3.9.6 Valley Sub-area

Valley is a Sub-area of the LA Basin LCR Area. The 2019 LCT study identified that the Valley Sub-area need is satisfied by the need in the larger Eastern LA Basin sub-area.

3.3.9.7 Eastern LA Basin Sub-area

Eastern LA Basin is a sub-area of the LA Basin LCR Area.

3.3.9.7.1 Eastern LA Basin LCR Sub-area Diagram

Please refer to Figure 3.3-101 above.

3.3.9.7.2 Eastern LA Basin LCR Sub-area Load and Resources

Table 3.3-79 provides the forecast load and resources in Eastern LA Basin LCR Sub-area in 2020. The list of generators within the LCR Sub-area are provided in Attachment A.

Table 3.3-79 Eastern LA Basin Sub-area 2020 Forecast Load and Resources

Load (MW)		Generation (MW)	NQC	At Peak
Gross Load	7692	Market, Net Seller, battery, Wind, Solar	2706	2706
AAEE	61	MUNI	528	528
Behind the meter DG	493	QF	177	177
Net Load	7138	LTPP Preferred Resources	0	0
Transmission Losses	107	Existing 20-minute Demand Response	141	141
Pumps	21	Mothballed	335	0
Load + Losses + Pumps	7266	Total	3887	3552

3.3.9.7.3 Eastern LA Basin LCR Sub-area Hourly Profiles

Figure 3.3-104 illustrates the forecast 2020 profile for the summer peak day in the Eastern LA Basin LCR Sub-area.

Figure 3.3-104 Eastern LA Basin LCR Sub-area 2020 Peak Day Forecast Profiles

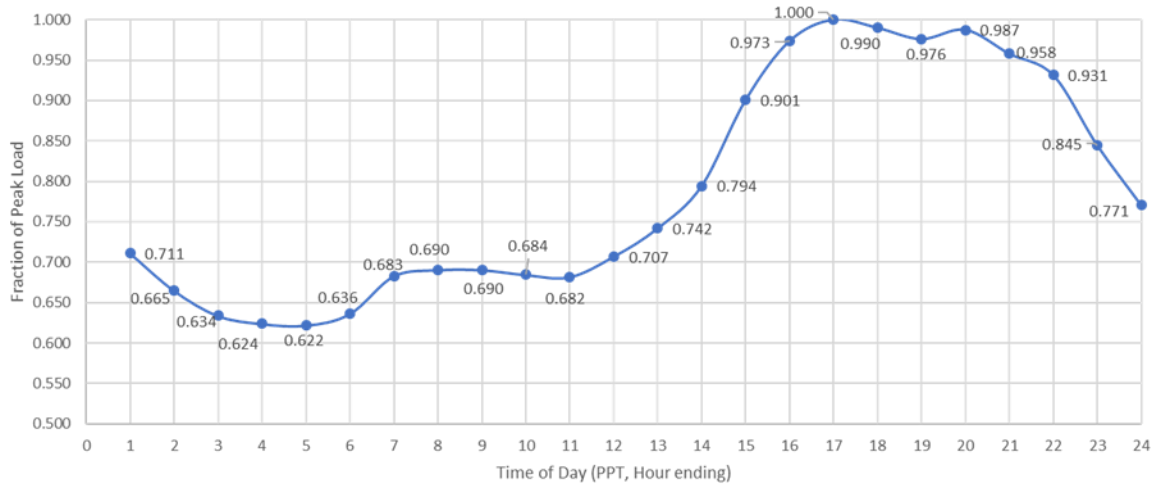

3.3.9.7.4 Eastern LA Basin LCR Sub-area Requirement

Table 3.3-80 identifies the sub-area LCR requirements. The Category B (Single Contingency) LCR requirement is non-binding and the LCR requirement for Category C (Multiple Contingency) is 2537 MW.

Table 3.3-80 Eastern LA Basin LCR Sub-area Requirements

Year	Limit	Category	Limiting Facility	Contingency	LCR (MW) (Deficiency)
2020	First Limit	B	Non-binding	Multiple combinations possible	N/A
2020	First Limit	C	Post transient voltage stability	Serrano – Valley 500 kV, followed by Devers – Red Bluff #1 and #2 500 kV	2537

3.3.9.7.5 Effectiveness factors:

All units within the Eastern LA Basin Sub-area have the same effectiveness factor.

For most helpful procurement information please read procedure 2210Z Effectiveness Factors under 7630 (G-219Z) posted at: <http://www.caiso.com/Documents/2210Z.pdf>

3.3.9.8 LA Basin Overall

3.3.9.8.1 LA Basin LCR Sub-area Hourly Profiles

Figure 3.3-105 illustrates the forecast 2020 profile for the summer peak day in the LA Basin LCR area.

Figure 3.3-105 LA Basin LCR area 2020 Peak Day Forecast Profiles

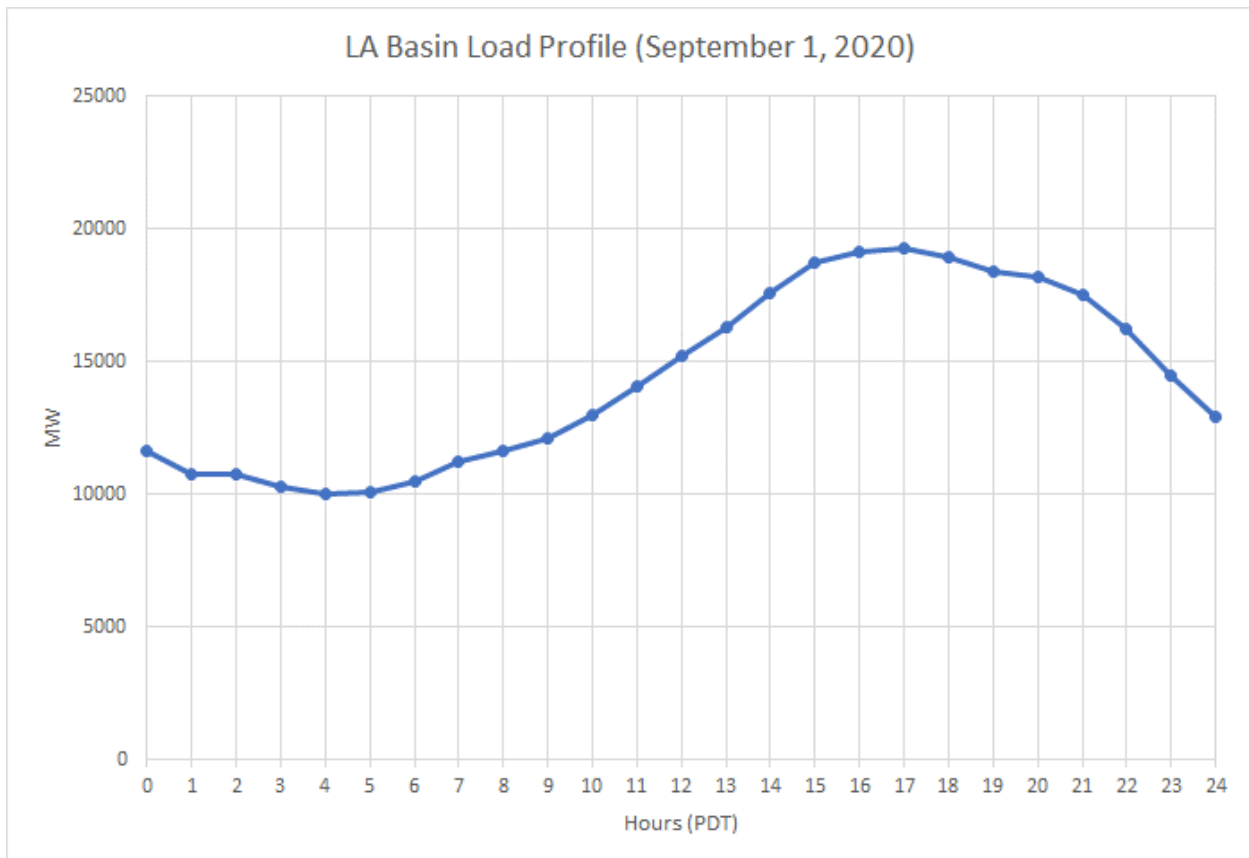

3.3.9.8.2 LA Basin LCR area Requirement

Table 3.3-81 identifies the area requirements. The Category B requirement (Single Contingency) and the LCR requirement for Category C (Multiple Contingency) are the same 7364 MW.

Table 3.3-81 LA Basin LCR area Requirements

Year	Limit	Category	Limiting Facility	Contingency	LCR (MW) (Deficiency)

2020	First Limit	B/C	Imperial Valley – El Centro 230 kV Line (S-Line)	TDM, system readjustment followed by Imperial Valley – North Gila 500 kV	7364
------	-------------	-----	--	--	------

Detailed explanation regarding coordination between LA Basin and San Diego-Imperial Valley:

To arrive at the above local capacity requirement, the ISO performed the study for the LA Basin in coordination with the San Diego-Imperial Valley area as these two areas are electrically interdependent due to retirement of San Onofre Nuclear Generating Station (SONGS) and other once-through-cooled generation in the area.

For this year’s local capacity requirement study, there are two major factors that affect the change in LCR need for the San Diego-Imperial Valley area, which subsequently affect the change in the LCR for the LA Basin as well:

- Modeling of expected solar generation output (i.e., 0 MW) at the time of forecast peak load (for San Diego area, the peak load is forecast to be at 8 p.m. PDT). This represents approximately 439 MW of unavailable local capacity at effective locations for the most constraint reliability concern for the area.
- Modeling San Diego peak load based on the CEC-adopted 2018 – 2030 California Energy Demand Update forecast, reflecting 201 MW higher than the previous year’s 2018-2030 CED forecast (2017 IEPR).

Anticipating potential reliability concerns due to the two major factors mentioned above for the San Diego-Imperial Valley local capacity area, the ISO performed the analyses to determine the local capacity need for the following scenarios:

- Scenario 1: Assess the LCR need for the San Diego – Imperial Valley area without increasing LA Basin local capacity. Identified the amount of deficient local capacity by assuming the additional capacity is located in the most effective location.
- Scenario 2: Assess the LCR need for the San Diego – Imperial Valley area based on all available and effective resources in San Diego and LA Basin. Increase local capacity in the LA Basin to help offset local capacity deficiency in the San Diego – Imperial Valley area as much as possible.
- Scenario 3: same as Scenario 2 but implementing actions to curtail imports to SDG&E via the southern 500 kV and 230 kV lines

The following table includes the study results for the three scenarios mentioned above.

Year	Limit	Category	Limiting Facility	Contingency	SD-IV LCR (MW) (Deficiency)	LA Basin LCR (MW) (Deficiency)
------	-------	----------	-------------------	-------------	-----------------------------	--------------------------------

2020	First Limit	B/C (S1)	Imperial Valley – El Centro 230 kV Line (S-Line)	TDM, system readjustment followed by Imperial Valley – North Gila 500 kV	4434 (100 NQC/ 539 Peak)	6214
2020	First Limit	B/C (S2)	Imperial Valley – El Centro 230 kV Line (S-Line)	TDM, system readjustment followed by Imperial Valley – North Gila 500 kV	4028 (133 Peak)	9650
2020	First Limit	B/C (S3)	Imperial Valley – El Centro 230 kV Line (S-Line)	TDM, system readjustment followed by Imperial Valley – North Gila 500 kV	3895	7364

3.3.9.8.3 Effectiveness factors:

See Attachment B - Table titled [LA Basin](#).

For other helpful procurement information please read procedure 2210Z Effectiveness Factors under 7570 (T-144Z), 7580 (T-139Z), 7590 (T-137Z, 6750) and 7680 (T-130Z) posted at: <http://www.caiso.com/Documents/2210Z.pdf>

There are other combinations of contingencies in the area that could overload other 230 kV lines in this sub-area resulting in less LCR need. As such, anyone of them (combination of contingencies) could become binding for any given set of procured resources. As a result, these effectiveness factors may not be the best indicator towards informed procurement.

3.3.9.8.4 Changes compared to 2019 LCT study

Compared with 2019, the CEC load forecast is lower by 812 MW and the LCR needs have decreased by 752 MW.

3.3.9.8.5 Sensitivity Study with the Lugo-Eldorado 500kV Line Out of Service

The ISO performed a sensitivity study with the Lugo-Eldorado 500 kV line out of service for maintenance, regarding the LCR need to the overall LA Basin–San Diego-Imperial Valley combined area. The ISO found the following:

- The S line loading concern was still the most limiting facility. Since there is no further available resources in the San Diego-Imperial Valley, an additional 311 MW would need to be dispatched in the LA Basin to mitigate S line loading concern.
- Therefore the LCR need in the LA Basin to be 7675 MW.

3.3.10 San Diego-Imperial Valley Area

3.3.10.1 *Area Definition:*

The transmission tie lines forming a boundary around the Greater San Diego-Imperial Valley area include:

- Imperial Valley – North Gila 500 kV Line
- Otay Mesa – Tijuana 230 kV Line
- San Onofre - San Luis Rey #1 230 kV Line
- San Onofre - San Luis Rey #2 230 kV Line
- San Onofre - San Luis Rey #3 230 kV Line
- San Onofre – Talega 230 kV #1 and #2 Lines
- Imperial Valley – El Centro 230 kV Line
- Imperial Valley – La Rosita 230 kV Line

The substations that delineate the Greater San Diego-Imperial Valley area are:

- Imperial Valley is in North Gila is out
- Otay Mesa is in Tijuana is out
- San Onofre is out San Luis Rey is in
- San Onofre is out San Luis Rey is in
- San Onofre is out San Luis Rey is in
- San Onofre is out Talega is in
- San Onofre is out Capistrano is in
- Imperial Valley is in El Centro is out
- Imperial Valley is in La Rosita is out

3.3.10.1.1 San Diego-Imperial Valley LCR Area Diagram

Figure 3.3-106 San Diego-Imperial Valley LCR Area

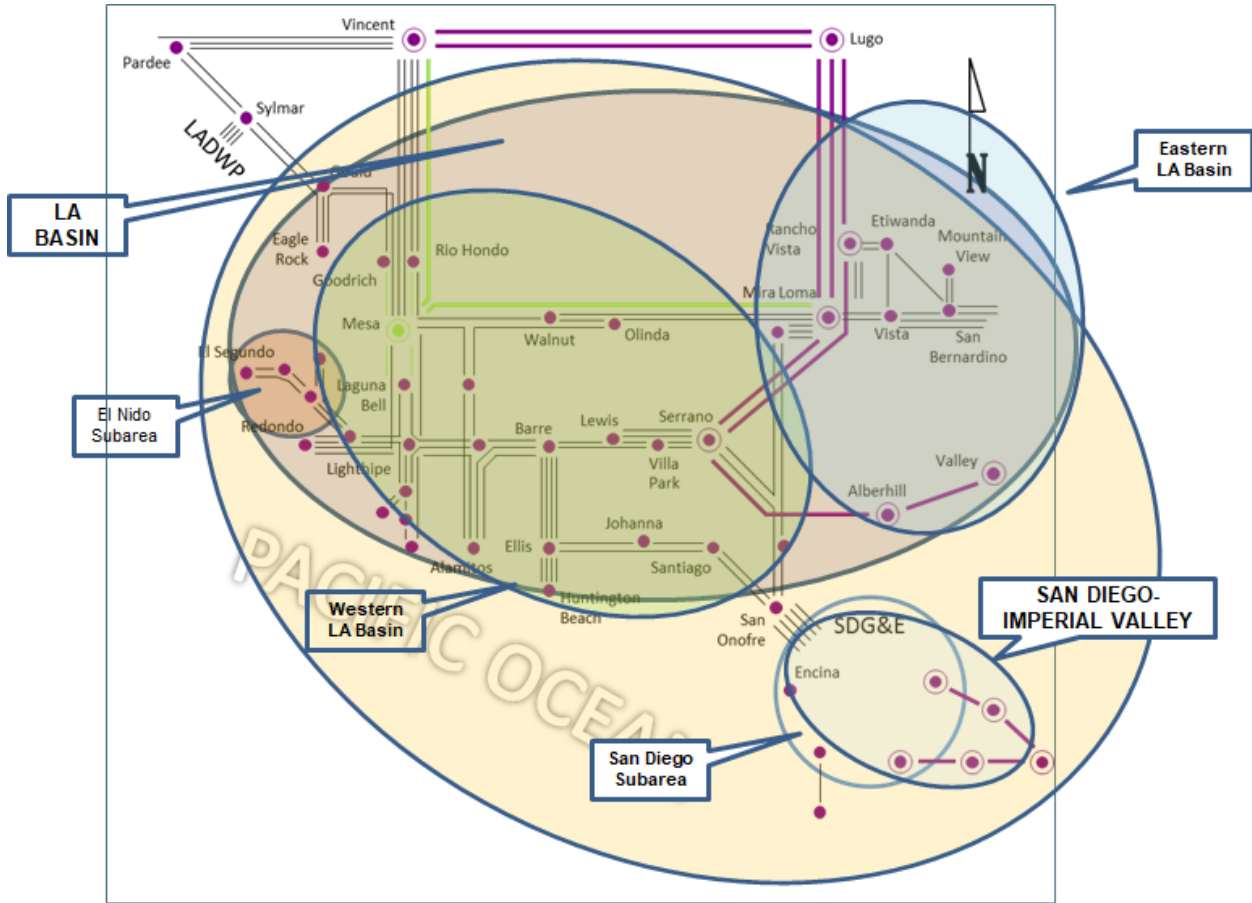

3.3.10.1.2 San Diego-Imperial Valley LCR Area Load and Resources

Table 3.3-82 provides the forecast load and resources in the San Diego-Imperial Valley LCR Area in 2020. The list of generators within the LCR area are provided in Attachment A.

In year 2020 the estimated time of local area peak is 8:00 PM (PDT).

At the local area peak time the estimated, behind the meter, solar output is 0.00%.

At the local area peak time the estimated, ISO metered, solar output is 0.00%.

If required, all non-solar technology type resources are dispatched at NQC.

Table 3.3-82 San Diego-Imperial Valley LCR Area 2020 Forecast Load and Resources

Load (MW)		Generation (MW)	NQC	At Peak
Gross Load	4648	Market, Net Seller, Battery, Wind	3875	3875
AAEE	-159	Solar	439	0
Behind the meter DG	0	QF	4	4

Net Load	4489	LTPP Preferred Resources	0	0
Transmission Losses	124	Existing 20-minute Demand Response	16	16
Pumps	0	Mothballed	0	0
Load + Losses + Pumps	4613	Total	4334	3895

3.3.10.1.3 Approved transmission projects modeled:

- Ocean Ranch 69 kV substation
- Mesa Height TL600 Loop-in
- Re-conductor of Mission-Mesa Heights 69 kV
- Re-conductor of Kearny-Mission 69 kV line
- Upgrade Bernardo - Rancho Carmel 69 kV line
- Re-conductor of Japanese Mesa–Baseline–Talega Tap 69 kV lines
- 2nd Miguel–Bay Boulevard 230 kV line
- 2nd Mission 230/69 kV bank
- Suncrest SVC project
- By-passing 500 kV series capacitor banks on the Southwest Powerlink and Sunrise Powerlink lines
- Generation retirements at Encina, North Island, and Division Naval Station)
- Carlsbad Energy Center (Encina repower) (5x100 MW)
- Battery energy storage projects (total of 113 MW) at various locations
- TL632 Granite loop-in and TL6914 reconfiguration
- 2nd Poway–Pomerado 69 kV line
- Imperial Valley bank #80 replacement

3.3.10.2 El Cajon Sub-area

El Cajon is Sub-area of the San Diego-Imperial Valley LCR Area.

3.3.10.2.1 El Cajon LCR Sub-area Diagram

Figure 3.3-107 El Cajon LCR Sub-area

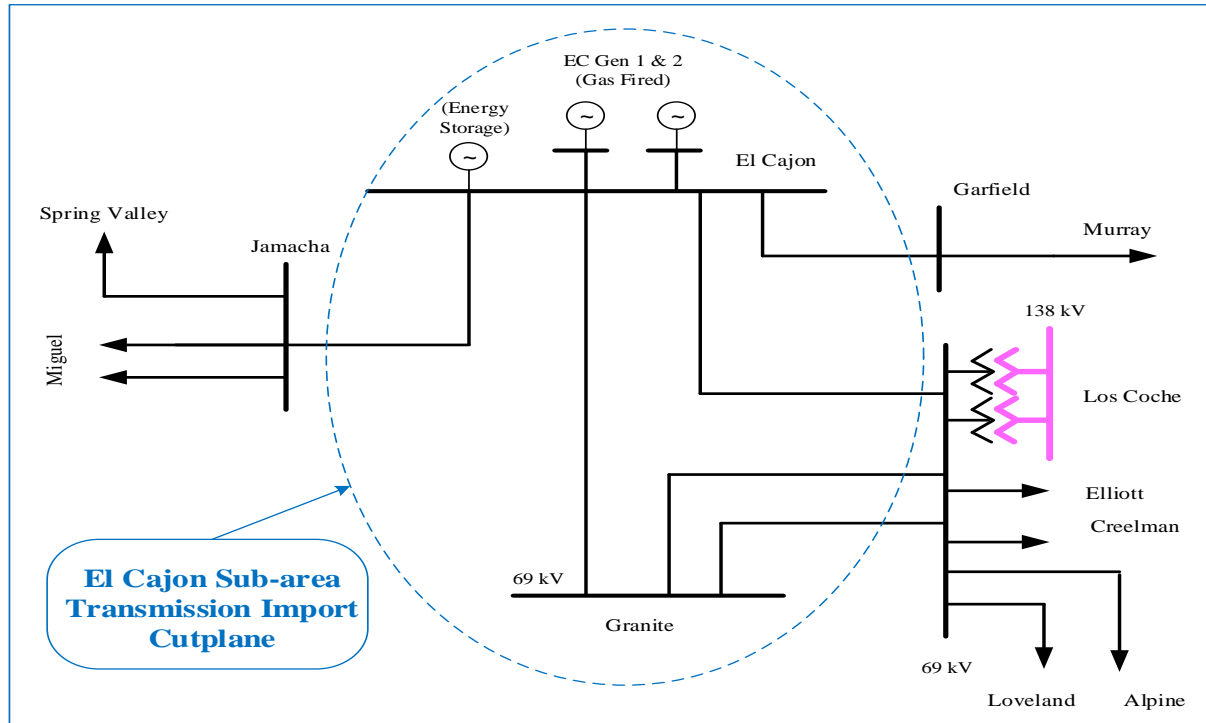

3.3.10.2.2 El Cajon LCR Sub-area Load and Resources

Table 3.3-83 provides the forecast load and resources in El Cajon LCR Sub-area in 2020. The list of generators within the LCR Sub-area are provided in Attachment A.

Table 3.3-83 El Cajon LCR Sub-area 2020 Forecast Load and Resources

Load (MW)		Generation (MW)	NQC	At Peak
Gross Load	172	Market, Net Seller, Battery	101	101
AAEE	-5	MUNI	0	0
Behind the meter DG	0	QF	0	0
Net Load	167	LTPP Preferred Resources	0	0
Transmission Losses	3	Existing 20-minute Demand Response	0	0
Pumps	0	Mothballed	0	0
Load + Losses + Pumps	170	Total	101	101

3.3.10.2.3 El Cajon LCR Sub-area Hourly Profiles

Figure 3.3-108 illustrates the forecast 2020 profile for the summer peak day in the El Cajon LCR Sub-area with the Category C (Multiple Contingency) transmission capability.

Figure 3.3-108 El Cajon LCR Sub-area 2020 Peak Day Forecast Profiles

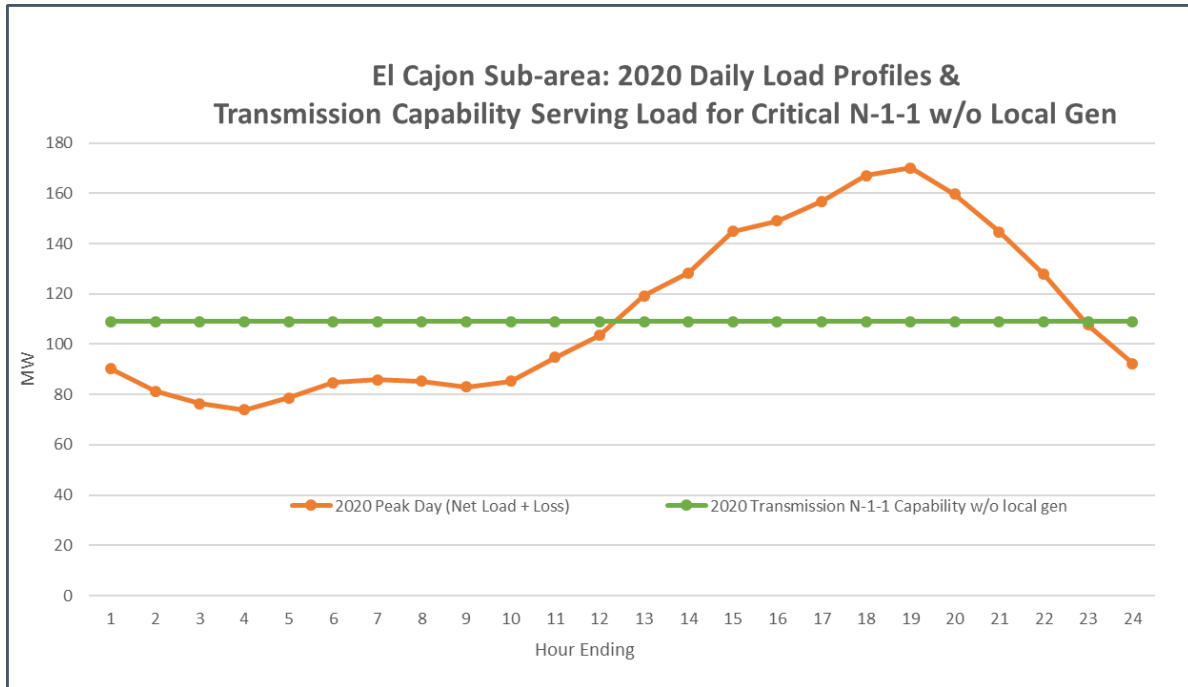

3.3.10.2.4 El Cajon LCR Sub-area Requirement

Table 3.3-84 identifies the sub-area LCR requirements. There are no LCR requirements for Category B (Single Contingency) and Category C (Multiple Contingency) is 78 MW.

Table 3.3-84 El Cajon LCR Sub-area Requirements

Year	Limit	Category	Limiting Facility	Contingency	LCR (MW) (Deficiency)
2020	First Limit	B	None	None	0
2020	First Limit	C	El Cajon – Los Coches 69 kV	Granite – Los Coches #1 & #2 69 kV	78

3.3.10.2.5 Effectiveness factors:

All units within the El Cajon Sub-area have the same effectiveness factor.

3.3.10.3 Mission Sub-area

Mission is a Sub-area of the San Diego-Imperial Valley LCR Area. The 2020 LCT study identified that the Mission Sub-area will no longer be required due to the TL600 Mesa Heights 69 kV Loop-in and the TL676 Mission-Mesa Heights 69 kV Reconductoring projects being in-service.

3.3.10.4 Esco Sub-area

Esco is Sub-area of the San Diego-Imperial Valley LCR Area.

3.3.10.4.1 Esco LCR Sub-area Diagram

Figure 3.3-109 Esco LCR Sub-area

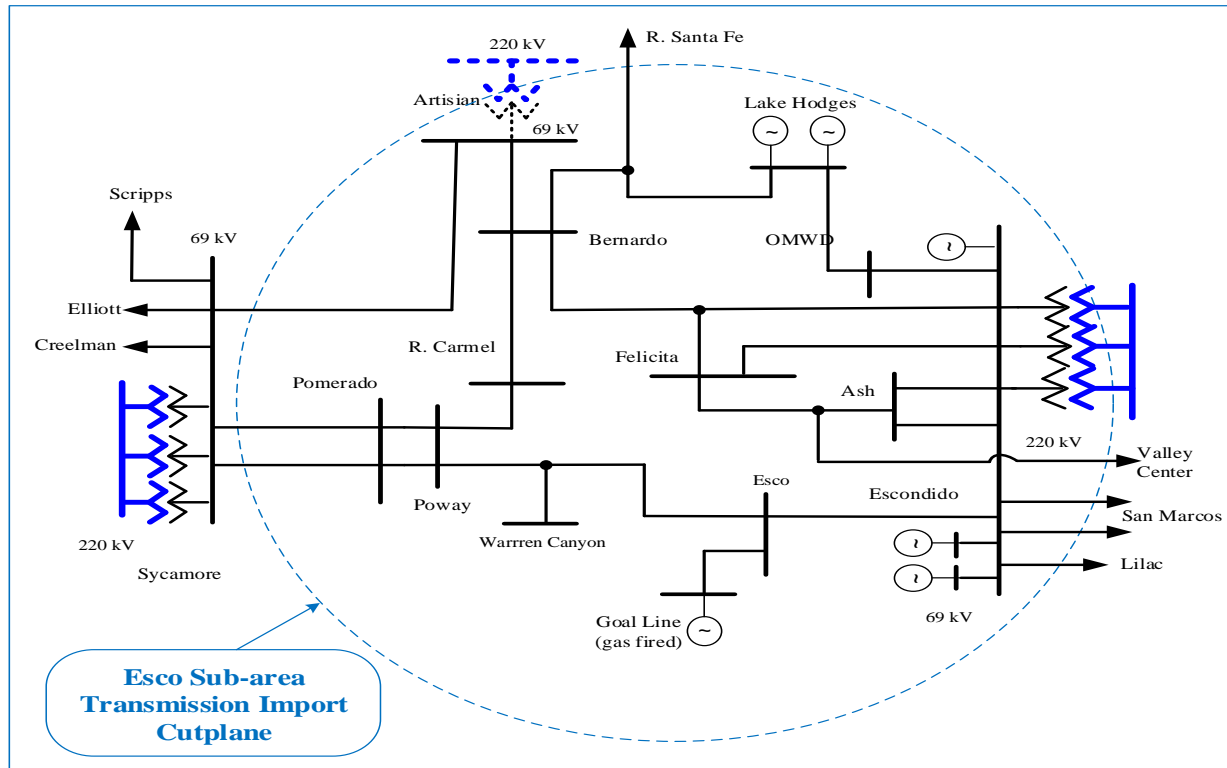

3.3.10.4.2 Esco LCR Sub-area Load and Resources

Table 3.3-85 provides the forecast load and resources in Esco LCR Sub-area in 2020. The list of generators within the LCR Sub-area are provided in Attachment A.

Table 3.3-85 Esco Sub-area 2020 Forecast Load and Resources

Load (MW)		Generation (MW)	NQC	At Peak
Gross Load	529	Market, Net Seller, Battery	203	203
AAEE	-17	MUNI	0	0
Behind the meter DG	0	QF	0	0
Net Load	512	Solar	4	0
Transmission Losses	5	Existing 20-minute Demand Response	0	0
Pumps	0	Mothballed	0	0

Load + Losses + Pumps	517	Total	207	203
-----------------------	-----	-------	-----	-----

3.3.10.4.3 Esco LCR Sub-area Hourly Profiles

Figure 3.3-110 illustrates the forecast 2020 profile for the summer day for in the Esco LCR Sub-area with the Category C (Multiple Contingency) transmission capability.

Figure 3.3-110 Esco LCR Sub-area 2020 Peak Day Forecast Profiles

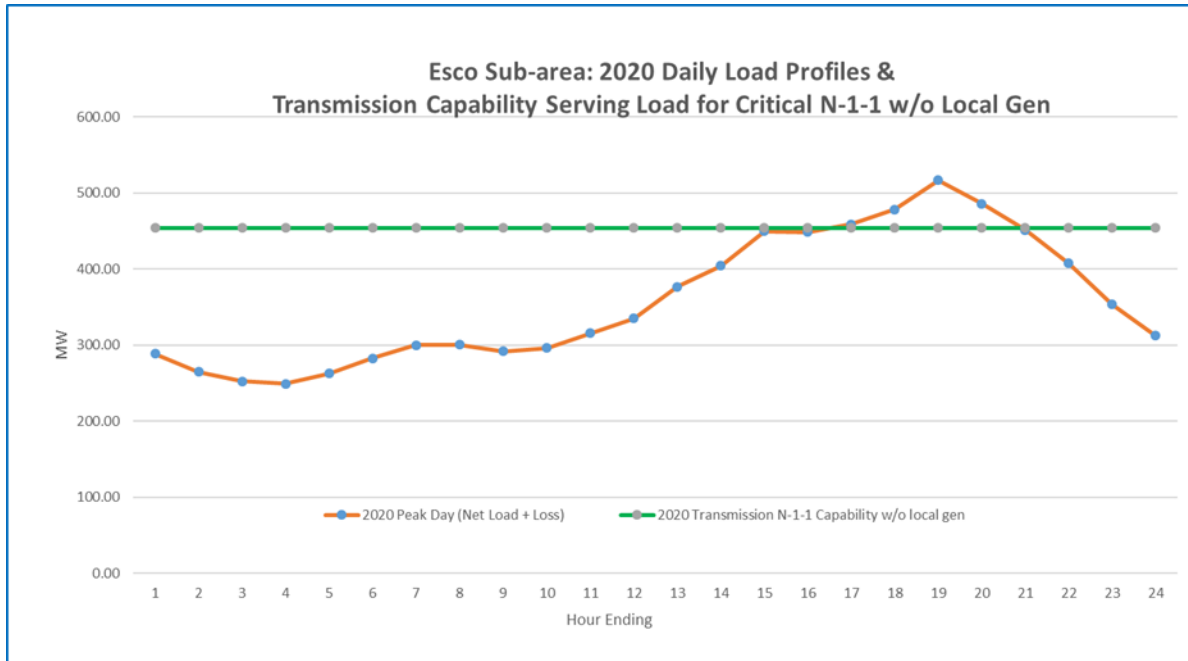

3.3.10.4.4 Esco LCR Sub-area Requirement

Table 3.3-86 identifies the sub-area requirements. There is no Category B (Single Contingency) LCR requirement and the Category C (Multiple Contingency) LCR requirement is 100 MW.

Table 3.3-86 Esco LCR Sub-area Requirements

Year	Limit	Category	Limiting Facility	Contingency	LCR (MW) (Deficiency)
2020	First Limit	B	None	None	0
2020	First Limit	C	Remaining Sycamore-Pomerado 69 kV line	One of Sycamore-Pomerado 69 kV (TL6915 or TL6924) and Sycamore-Artesian 69 kV (TL6920) lines	100

3.3.10.4.5 Effectiveness factors:

All units within the Esco Sub-area have the same effectiveness factor.

3.3.10.5 Pala Inner Sub-area

Pala Inner is Sub-area of the San Diego-Imperial Valley LCR Area.

3.3.10.5.1 Pala Inner LCR Sub-area Diagram

Figure 3.3-111 Pala Inner LCR Sub-area

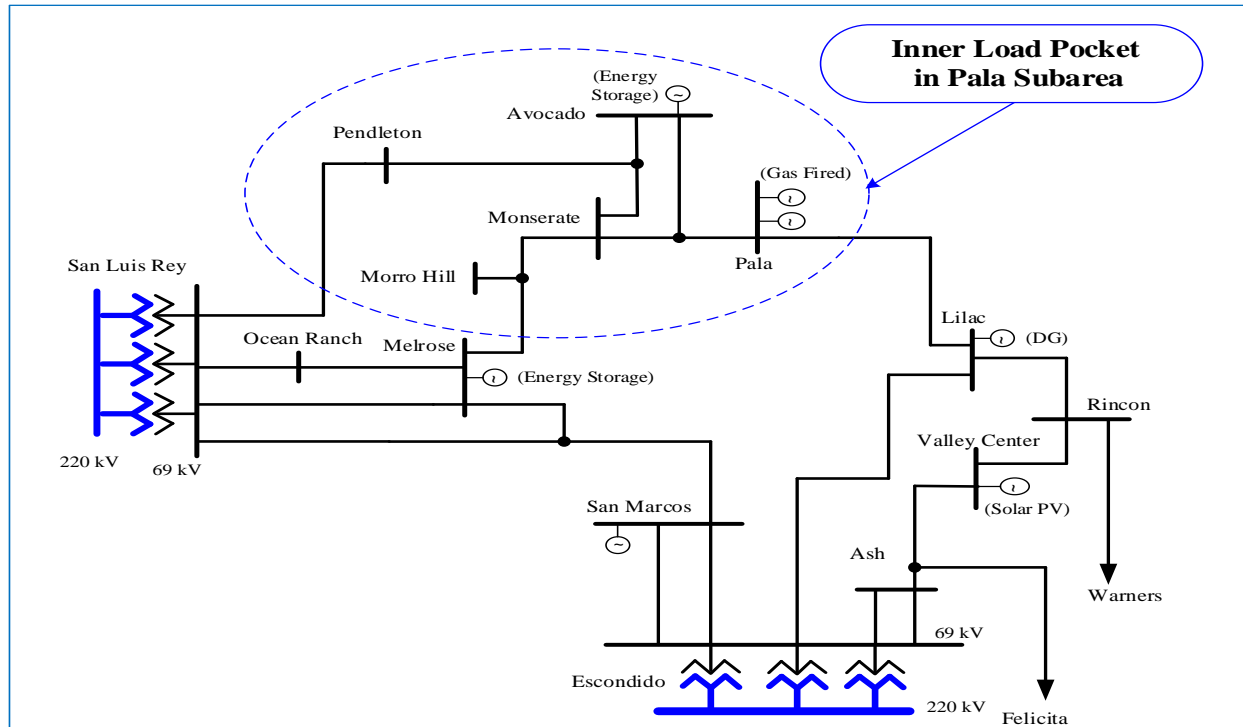

3.3.10.5.2 Pala Inner LCR Sub-area Load and Resources

Table 3.3-87 provides the forecast load and resources in Pala Inner LCR Sub-area in 2020. The list of generators within the LCR Sub-area are provided in Attachment A.

Table 3.3-87 Pala Inner Sub-area 2020 Forecast Load and Resources

Load (MW)		Generation (MW)	NQC	At Peak
Gross Load	163	Market, Net Seller, Battery	98	98
AEE	-7	MUNI	0	0
Behind the meter DG	0	QF	0	0
Net Load	156	LTPP Preferred Resources	0	0
Transmission Losses	5	Existing 20-minute Demand Response	0	0

Pumps	0	Mothballed	0	0
Load + Losses + Pumps	161	Total	98	98

3.3.10.5.3 Pala Inner LCR Sub-area Hourly Profiles

Figure 3.3-112 illustrates the forecast 2020 profile for the summer peak day for the Pala Inner LCR Sub-area with the Category C (Multiple Contingency) transmission capability.

Figure 3.3-112 Pala Inner LCR Sub-area 2020 Peak Day Forecast Profiles

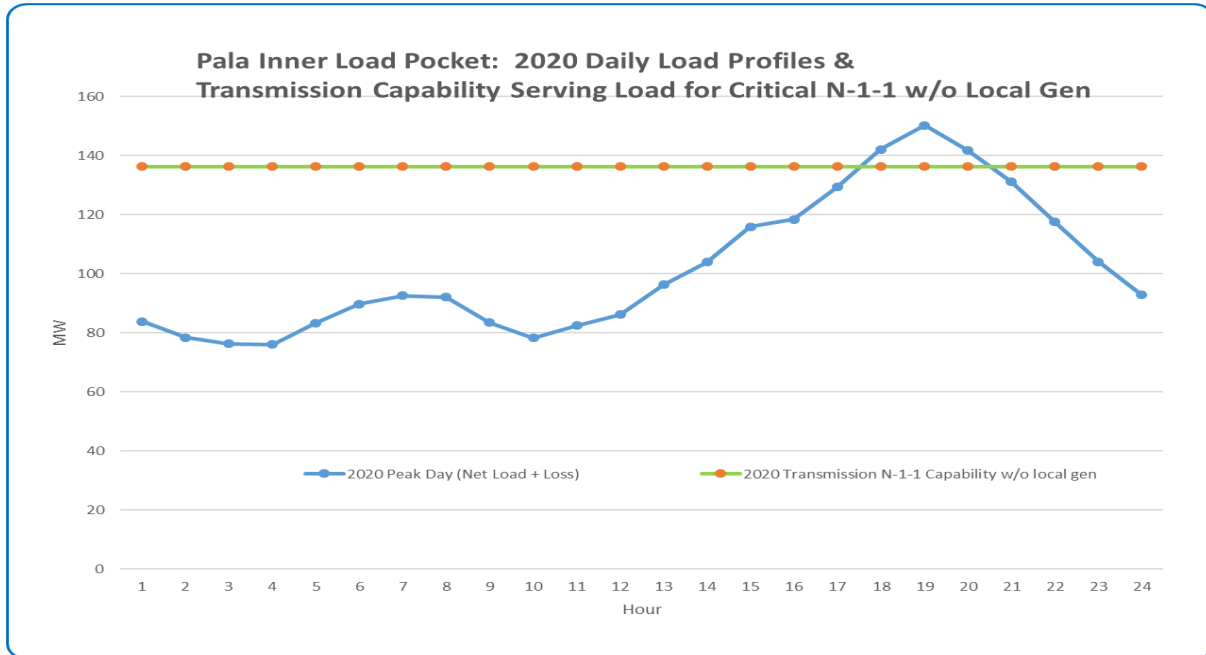

3.3.10.5.4 Pala Inner LCR Sub-area Requirement

Table 3.3-88 identifies the sub-area requirements. There is no Category B (Single Contingency) LCR requirement and the LCR requirement for Category C (Multiple Contingency) is 19 MW.

Table 3.3-88 Pala Inner LCR Sub-area Requirements

Year	Limit	Category	Limiting Facility	Contingency	LCR (MW) (Deficiency)
2020	First Limit	B	None	None	0
2020	First Limit	C	Melrose – Morro Hill Tap 69 kV (TL694)	Pendleton – San Luis Rey 69 kV (TL6912) & Lilac – Pala 69 kV (TL6932)	19

3.3.10.5.5 Effectiveness factors:

All units within the Pala Inner Sub-area have the same effectiveness factor.

3.3.10.6 Pala Outer Sub-area

Pala Outer is Sub-area of the San Diego-Imperial Valley LCR Area.

3.3.10.6.1 Pala Outer LCR Sub-area Diagram

Figure 3.3-113 Pala Outer LCR Sub-area

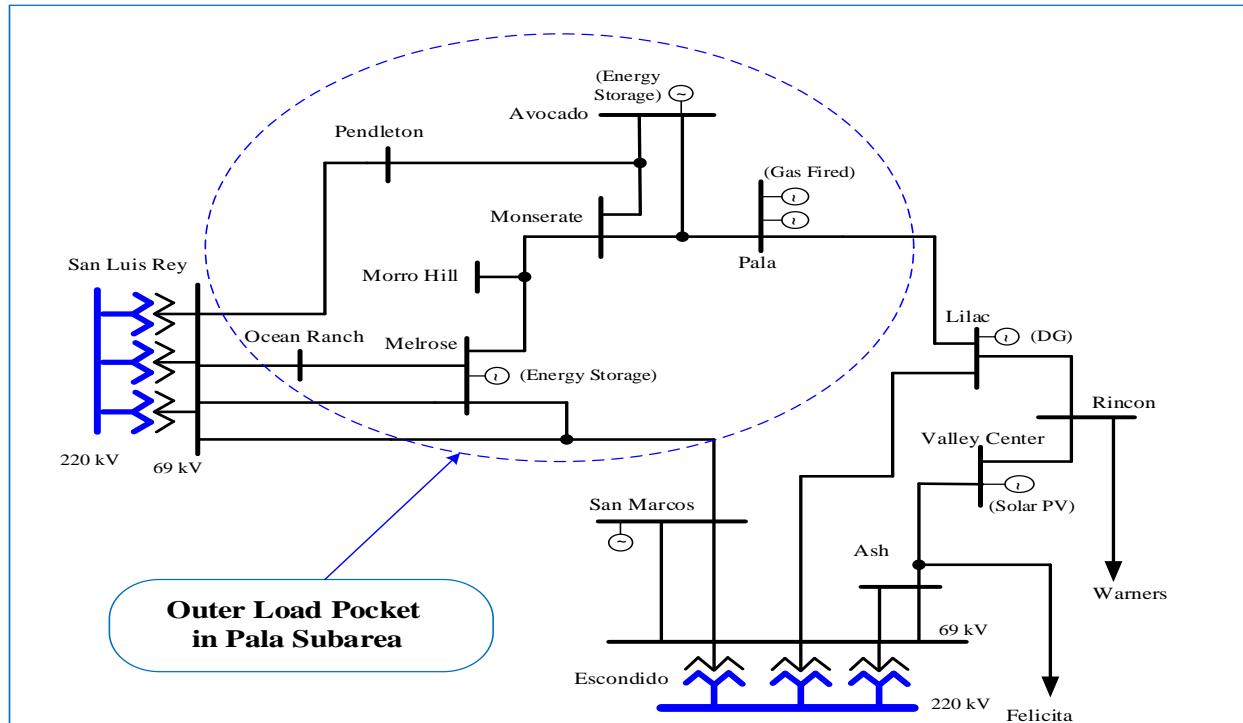

3.3.10.6.2 Pala Outer LCR Sub-area Load and Resources

Table 3.3-89 provides the forecast load and resources in Pala Outer LCR Sub-area in 2020. The list of generators within the LCR Sub-area are provided in Attachment A.

Table 3.3-89 Pala Outer Sub-area 2020 Forecast Load and Resources

Load (MW)		Generation (MW)		NQC	At Peak
Gross Load	262	Market		109	109
AAEE	-10	MUNI		0	0
Behind the meter DG	0	QF		0	0
Net Load	252	LTPP Preferred Resources		0	0

Transmission Losses	7	Existing 20-minute Demand Response	0	0
Pumps	0	Mothballed	0	0
Load + Losses + Pumps	259	Total	109	109

3.3.10.6.3 Pala Outer LCR Sub-area Hourly Profiles

Figure 3.3-114 illustrates the forecast 2020 profile for the summer peak day for the Pala Outer LCR Sub-area with the Category C (Multiple Contingency) transmission capability.

Figure 3.3-114 Pala Outer LCR Sub-area 2020 Peak Day Forecast Profiles

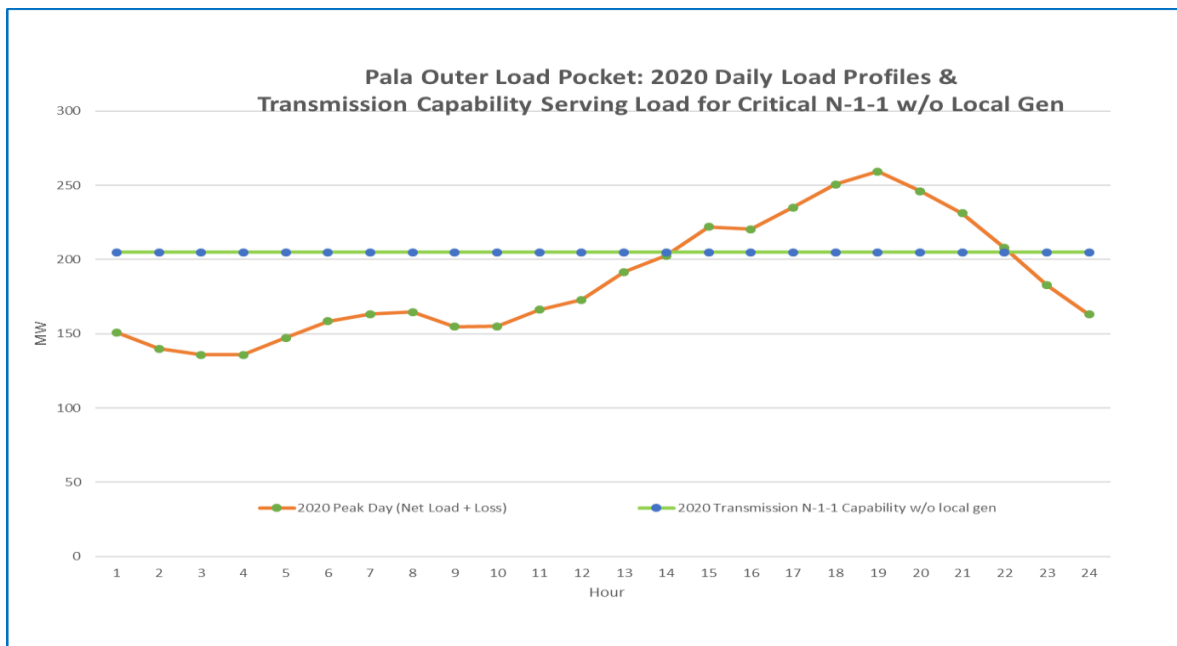

3.3.10.6.4 Pala Outer LCR Sub-area Requirement

Table 3.3-90 identifies the sub-area requirements. There is no Category B (Single Contingency) LCR requirement and the LCR requirement for Category C (Multiple Contingency) is 65 MW.

Table 3.3-90 Pala Outer LCR Sub-area Requirements

Year	Limit	Category	Limiting Facility	Contingency	LCR (MW) (Deficiency)
2020	First Limit	B	None	None	0

2020	First Limit	C	San Luis Rey – Ocean Ranch 69 kV	San Luis Rey-Melrose (TL693) and San Luis Rey-Melrose-San Marcos 3-terminal (TL680) 69 kV lines	65
------	-------------	---	----------------------------------	---	----

3.3.10.6.5 Effectiveness factors:

All units within the Pala Outer Sub-area have the same effectiveness factor.

3.3.10.7 Border Sub-area

Border is Sub-area of the San Diego-Imperial Valley LCR Area.

3.3.10.7.1 Border LCR Sub-area Diagram

Figure 3.3-115 Border LCR Sub-area

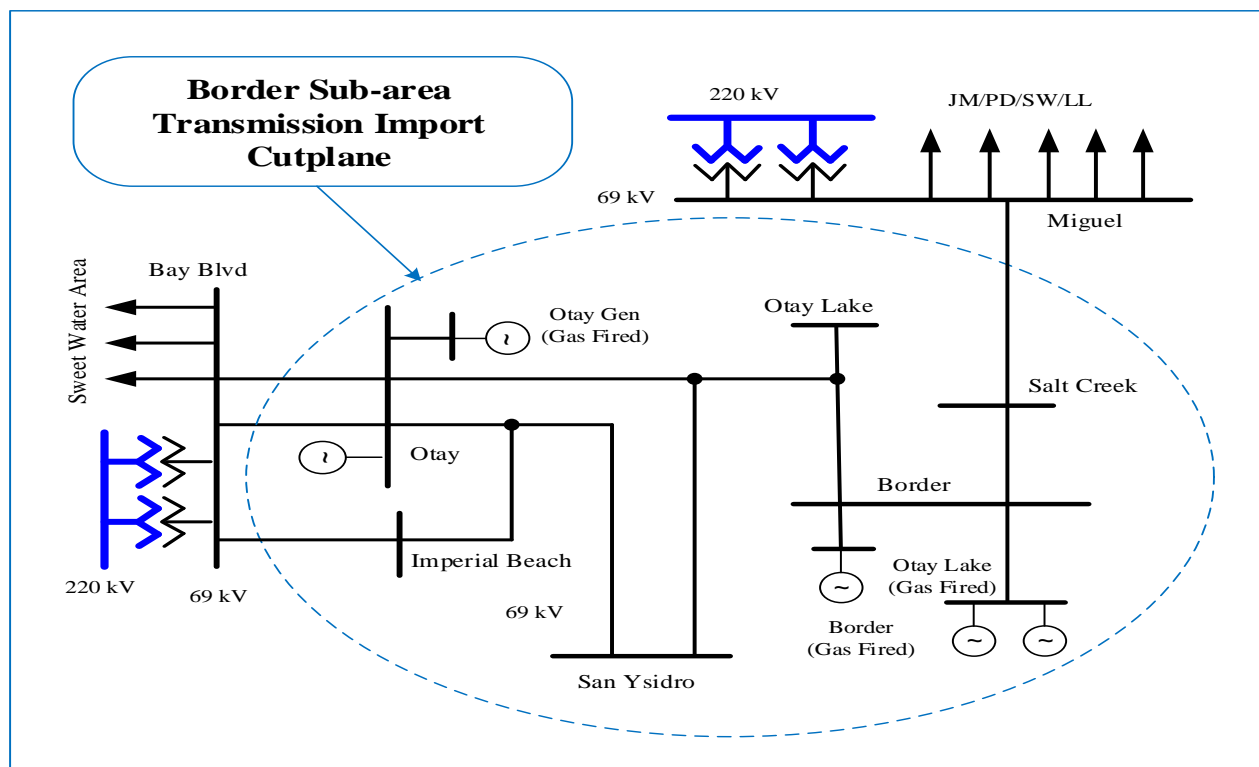

3.3.10.7.2 Border LCR Sub-area Load and Resources

Table 3.3-91 provides the forecast load and resources in Border LCR Sub-area in 2020. The list of generators within the LCR Sub-area are provided in Attachment A.

Table 3.3-91 Border Sub-area 2020 Forecast Load and Resources

Load (MW)	Generation (MW)	NQC	At Peak
-----------	-----------------	-----	---------

Gross Load	165	Market, Net Seller, Battery	178	178
AAEE	-8	MUNI	0	0
Behind the meter DG	0	QF	0	0
Net Load	157	LTPP Preferred Resources	0	0
Transmission Losses	2	Existing 20-minute Demand Response	0	0
Pumps	0	Mothballed	0	0
Load + Losses + Pumps	159	Total	178	178

3.3.10.7.3 Border LCR Sub-area Hourly Profiles

Figure 3.3-116 illustrates the forecast 2020 profile for the summer peak day for the Border LCR Sub-area with the Category C (Multiple Contingency) transmission capability.

Figure 3.3-116 Border LCR Sub-area 2020 Peak Day Forecast Profiles

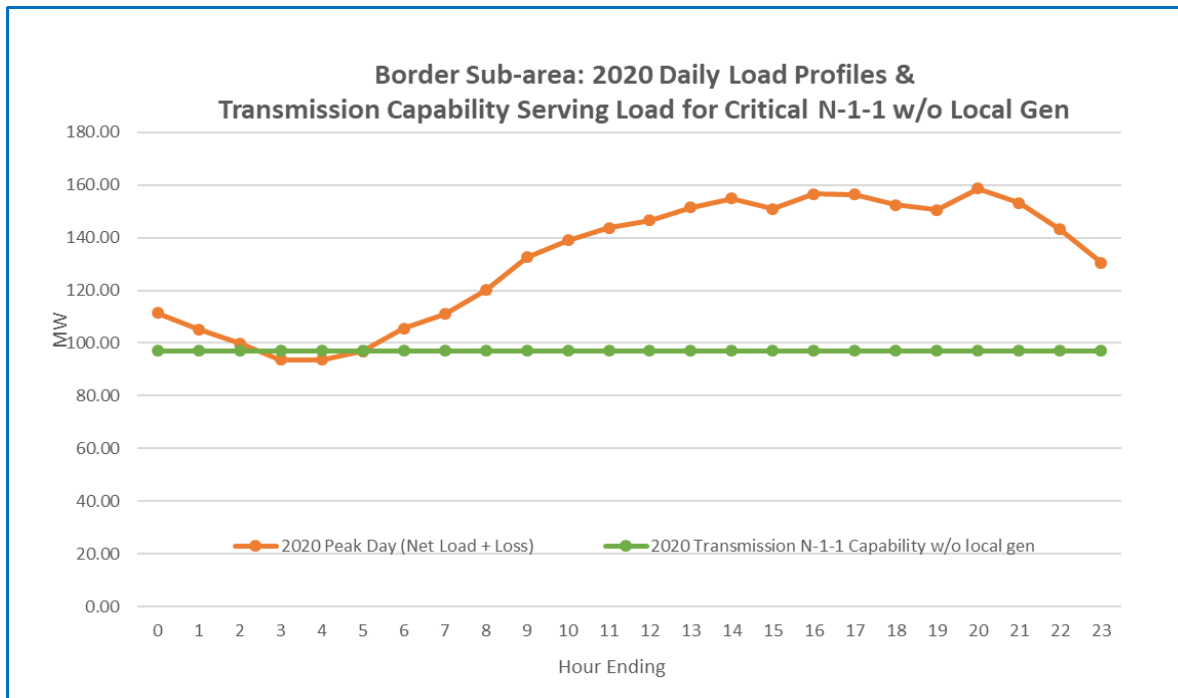

3.3.10.7.4 Border LCR Sub-area Requirement

Table 3.3-92 identifies the sub-area requirements. The LCR requirement for Category B (Single Contingency) is 61 MW and for Category C (Multiple Contingency) is 65 MW.

Table 3.3-92 Border LCR Sub-area Requirements

Year	Limit	Category	Limiting Facility	Contingency	LCR (MW) (Deficiency)
2020	First Limit	B	Otay – Otay Lake Tap 69 kV	Miguel – Salt Creek 69 kV with Border unit out of service	61
2020	First Limit	C	Imperial Beach – Bay Boulevard 69 kV	Bay Boulevard – Otay #1 69 kV Bay Boulevard – Otay #2 69 kV	65

3.3.10.7.5 Effectiveness factors:

All units within the Border Sub-area have the same effectiveness factor.

3.3.10.8 San Diego Sub-area

San Diego is Sub-area of the San Diego-Imperial Valley LCR Area.

3.3.10.8.1 San Diego LCR Sub-area Diagram

Please refer to Figure 3.3-106 above.

3.3.10.8.2 San Diego LCR Sub-area Load and Resources

Table 3.3-93 provides the forecast load and resources in San Diego LCR Sub-area in 2020. The list of generators within the LCR Sub-area are provided in Attachment A.

Table 3.3-93 San Diego Sub-area 2020 Forecast Load and Resources

Load (MW)		Generation (MW)	NQC	At Peak
Gross Load	4648	Market, Net Seller, Battery, Wind	2788	2788
AAEE	-159	Solar	23	0
Behind the meter DG	0	QF	4	4
Net Load	4489	LTPP Preferred Resources	0	0
Transmission Losses	124	Existing 20-minute Demand Response	16	16
Pumps	0	Mothballed	0	0
Load + Losses + Pumps	4613	Total	2831	2808

3.3.10.8.3 San Diego LCR Sub-area Hourly Profiles

Figure 3.3-117 illustrates the forecast 2020 profile for the summer peak day for the San Diego LCR Sub-area.

Figure 3.3-117 San Diego LCR Sub-area 2020 Peak Day Forecast Profiles

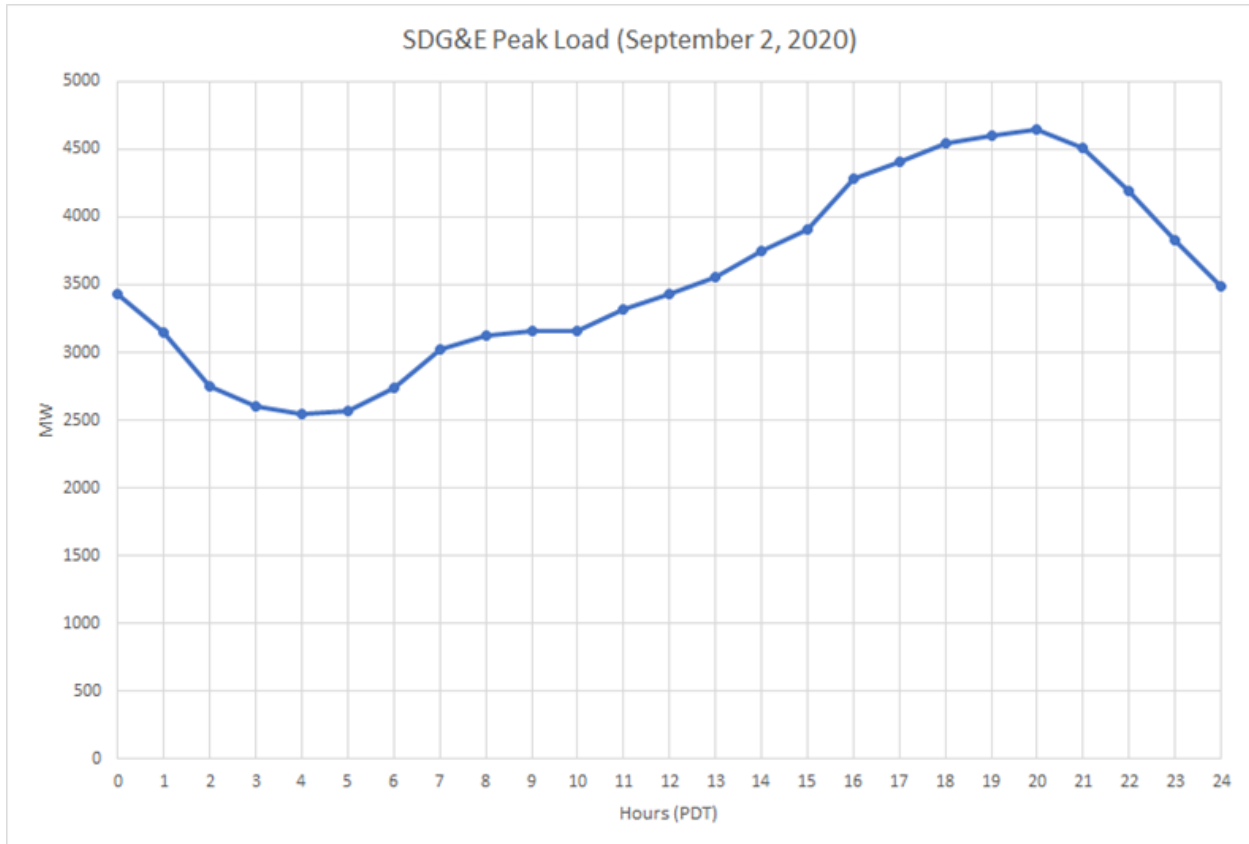

3.3.10.8.4 San Diego LCR Sub-area Requirement

Table 3.3-94 identifies the sub-area LCR requirements. The Category B (Single Contingency) LCR requirement is non-binding and the LCR requirement for Category C (Multiple Contingency) is 2642 MW.

Table 3.3-94 San Diego LCR Sub-area Requirements

Year	Limit	Category	Limiting Facility	Contingency	LCR (MW) (Deficiency)
2020	First Limit	B	Non-binding	Multiple combinations possible.	N/A

2020	First Limit	C	Remaining Sycamore – Suncrest 230 kV	Eco – Miguel 500 kV, system readjustment followed by one of the Sycamore – Suncrest 230 kV lines	2642
------	-------------	---	--------------------------------------	--	------

3.3.10.8.5 Effectiveness factors:

See Attachment B - Table titled [San Diego](#).

For other helpful procurement information please read procedure 2210Z Effectiveness Factors under 7820 (T-132Z) posted at: <http://www.aiso.com/Documents/2210Z.pdf>

3.3.10.9 San Diego-Imperial Valley Overall

3.3.10.9.1 San Diego-Imperial Valley LCR area Hourly Profiles

Same as San Diego Sub-area (see Figure 3.3-118 above).

3.3.10.9.2 San Diego-Imperial Valley LCR area Requirement

Table 3.3-95 identifies the area LCR requirements. The LCR requirement for Category B (Single Contingency) and Category C (Multiple Contingency) is the same 3895 MW.

Table 3.3-95 San Diego-Imperial Valley LCR area Requirements

Year	Limit	Category	Limiting Facility	Contingency	LCR (MW) (Deficiency)
2020	First Limit	B/C	Imperial Valley-El Centro 230 kV	TDM, system readjustment and Imperial Valley–North Gila 500 kV	3895

Detailed explanation regarding coordination between LA Basin and San Diego-Imperial Valley can be found in section 3.3.9.8.2 above.

3.3.10.9.3 Effectiveness factors:

See Attachment B - Table titled [San Diego](#).

For other helpful procurement information please read procedure 2210Z Effectiveness Factors under 7820 (T-132Z) posted at: <http://www.aiso.com/Documents/2210Z.pdf>

3.3.10.9.4 Changes compared to 2019 LCT Study

Compared with the 2019 LCT Study results, the demand forecast is higher by 201 MW. The overall LCR needs for the San Diego-Imperial Valley has decreased by 131 MW. The reasons for the decrease in the LCR need are:

- With the peak load shifts to early evening hour, the San Diego –Imperial Valley loses the local capacity contribution from the solar generation in the area. The 3,895 MW is the total available local capacity for the LCR area at the 8 p.m. peak load.
- A combination of mitigation measures were evaluated, including curtailment of imports that flow on the southern 500 kV and 230 kV transmission lines into San Diego. Generation redispatch on the available resources, mainly in the SCE area, was also included. The Yucca 69 kV Overload Scheme was assumed to be an active RAS based on the Arizona Security Monitoring Manual.

3.3.11 Valley Electric Area

Valley Electric Association LCR area has been eliminated on the basis of the following:

- No generation exists in this area
- No category B issues were observed in this area
- Category C and beyond –
 - No common-mode N-2 issues were observed
 - No issues were observed for category B outage followed by a common-mode N-2 outage
 - All the N-1-1 issues that were observed can either be mitigated by the existing UVLS or by an operating procedure

Attachment A – List of physical resources by PTO, local area and market ID

PTO	MKT/SCHED RESOURCE ID	BUS #	BUS NAME	kV	NQC	UNIT ID	LCR AREA NAME	LCR SUB-AREA NAME	NQC Comments	CAISO Tag
PG&E	ALMEGT_1_UNIT 1	38118	ALMDACT1	13.8	23.40	1	Bay Area	Oakland		MUNI
PG&E	ALMEGT_1_UNIT 2	38119	ALMDACT2	13.8	23.50	1	Bay Area	Oakland		MUNI
PG&E	BANKPP_2_NSPIN	38820	DELTA A	13.2	11.55	1	Bay Area	Contra Costa	Pumps	MUNI
PG&E	BANKPP_2_NSPIN	38820	DELTA A	13.2	11.55	2	Bay Area	Contra Costa	Pumps	MUNI
PG&E	BANKPP_2_NSPIN	38820	DELTA A	13.2	11.55	3	Bay Area	Contra Costa	Pumps	MUNI
PG&E	BANKPP_2_NSPIN	38815	DELTA B	13.2	11.55	4	Bay Area	Contra Costa	Pumps	MUNI
PG&E	BANKPP_2_NSPIN	38815	DELTA B	13.2	11.55	5	Bay Area	Contra Costa	Pumps	MUNI
PG&E	BANKPP_2_NSPIN	38770	DELTA C	13.2	11.55	6	Bay Area	Contra Costa	Pumps	MUNI
PG&E	BANKPP_2_NSPIN	38770	DELTA C	13.2	11.55	7	Bay Area	Contra Costa	Pumps	MUNI
PG&E	BANKPP_2_NSPIN	38765	DELTA D	13.2	11.55	8	Bay Area	Contra Costa	Pumps	MUNI
PG&E	BANKPP_2_NSPIN	38765	DELTA D	13.2	11.55	9	Bay Area	Contra Costa	Pumps	MUNI
PG&E	BANKPP_2_NSPIN	38760	DELTA E	13.2	11.55	10	Bay Area	Contra Costa	Pumps	MUNI
PG&E	BANKPP_2_NSPIN	38760	DELTA E	13.2	11.55	11	Bay Area	Contra Costa	Pumps	MUNI
PG&E	BRDSLD_2_HIWIND	32172	HIGHWINDS	34.5	42.93	1	Bay Area	Contra Costa	Aug NQC	Wind
PG&E	BRDSLD_2_MTZUM2	32179	MNTZUMA2	0.69	20.72	1	Bay Area	Contra Costa	Aug NQC	Wind
PG&E	BRDSLD_2_MTZUMA	32188	HIGHWND3	0.69	9.75	1	Bay Area	Contra Costa	Aug NQC	Wind
PG&E	BRDSLD_2_SHILO1	32176	SHILOH	34.5	39.75	1	Bay Area	Contra Costa	Aug NQC	Wind
PG&E	BRDSLD_2_SHILO2	32177	SHILOH 2	34.5	39.75	1	Bay Area	Contra Costa	Aug NQC	Wind
PG&E	BRDSLD_2_SHLO3A	32191	SHILOH3	0.58	27.16	1	Bay Area	Contra Costa	Aug NQC	Wind
PG&E	BRDSLD_2_SHLO3B	32194	SHILOH4	0.58	26.50	1	Bay Area	Contra Costa	Aug NQC	Wind
PG&E	CALPIN_1_AGNEW	35860	OLS-AGNE	9.11	28.56	1	Bay Area	San Jose, South Bay-Moss Landing	Aug NQC	Market
PG&E	CAYTNO_2_VASCO	30531	0162-WD	230	4.30	FW	Bay Area	Contra Costa	Aug NQC	Market
PG&E	CLRMTK_1_QF				0.00		Bay Area	Oakland	Not modeled	QF/Selfgen
PG&E	COCOPP_2_CTG1	33188	MARSHCT1	16.4	200.30	1	Bay Area	Contra Costa	Aug NQC	Market

Attachment A - List of physical resources by PTO, local area and market ID

PG&E	COCOPP_2_CTG2	33188	MARSHCT2	16.4	199.70	2	Bay Area	Contra Costa	Aug NQC	Market
PG&E	COCOPP_2_CTG3	33189	MARSHCT3	16.4	199.00	3	Bay Area	Contra Costa	Aug NQC	Market
PG&E	COCOPP_2_CTG4	33189	MARSHCT4	16.4	199.70	4	Bay Area	Contra Costa	Aug NQC	Market
PG&E	COCOSB_6_SOLAR				0.00		Bay Area	Contra Costa	Not modeled Energy Only	Solar
PG&E	CROKET_7_UNIT	32900	CRCKTCOG	18	220.00	1	Bay Area	Pittsburg	Aug NQC	QF/Selfgen
PG&E	CSCCOG_1_UNIT 1	36859	Laf300	12	3.00	1	Bay Area	San Jose, South Bay-Moss Landing		MUNI
PG&E	CSCCOG_1_UNIT 1	36859	Laf300	12	3.00	2	Bay Area	San Jose, South Bay-Moss Landing		MUNI
PG&E	CSCGNR_1_UNIT 1	36858	Gia100	13.8	24.00	1	Bay Area	San Jose, South Bay-Moss Landing		MUNI
PG&E	CSCGNR_1_UNIT 2	36895	Gia200	13.8	24.00	2	Bay Area	San Jose, South Bay-Moss Landing		MUNI
PG&E	CUMBIA_1_SOLAR	33102	COLUMBIA	0.38	7.79	1	Bay Area	Pittsburg	Aug NQC	Solar
PG&E	DELTA_2_PL1X4	33108	DEC CTG1	18	181.13	1	Bay Area	Pittsburg	Aug NQC	Market
PG&E	DELTA_2_PL1X4	33109	DEC CTG2	18	181.13	1	Bay Area	Pittsburg	Aug NQC	Market
PG&E	DELTA_2_PL1X4	33110	DEC CTG3	18	181.13	1	Bay Area	Pittsburg	Aug NQC	Market
PG&E	DELTA_2_PL1X4	33107	DEC STG1	24	269.60	1	Bay Area	Pittsburg	Aug NQC	Market
PG&E	DIXNLD_1_LNDFL				1.02		Bay Area		Not modeled Aug NQC	Market
PG&E	DUANE_1_PL1X3	36865	DVRaST3	13.8	48.36	1	Bay Area	San Jose, South Bay-Moss Landing		MUNI
PG&E	DUANE_1_PL1X3	36863	DVRaGT1	13.8	49.72	1	Bay Area	San Jose, South Bay-Moss Landing		MUNI
PG&E	DUANE_1_PL1X3	36864	DVRbGT2	13.8	49.72	1	Bay Area	San Jose, South Bay-Moss Landing		MUNI
PG&E	GATWAY_2_PL1X3	33119	GATEWAY2	18	181.50	1	Bay Area	Contra Costa	Aug NQC	Market
PG&E	GATWAY_2_PL1X3	33120	GATEWAY3	18	181.50	1	Bay Area	Contra Costa	Aug NQC	Market
PG&E	GATWAY_2_PL1X3	33118	GATEWAY1	18	191.69	1	Bay Area	Contra Costa	Aug NQC	Market
PG&E	GILROY_1_UNIT	35850	GLRY COG	13.8	69.00	1	Bay Area	Llagas, South Bay-Moss Landing	Aug NQC	Market
PG&E	GILROY_1_UNIT	35850	GLRY COG	13.8	36.00	2	Bay Area	Llagas, South Bay-Moss Landing	Aug NQC	Market
PG&E	GILRPP_1_PL1X2	35851	GROYPKR1	13.8	47.60	1	Bay Area	Llagas, South Bay-Moss Landing	Aug NQC	Market
PG&E	GILRPP_1_PL1X2	35852	GROYPKR2	13.8	47.60	1	Bay Area	Llagas, South Bay-Moss Landing	Aug NQC	Market

Attachment A - List of physical resources by PTO, local area and market ID

PG&E	GILRPP_1_PL3X4	35853	GROYPKR3	13.8	46.20	1	Bay Area	Llagas, South Bay-Moss Landing	Aug NQC	Market
PG&E	GRZZLY_1_BERKLY	32741	HILLSIDE_12	12.4 7	23.47	1	Bay Area		Aug NQC	Net Seller
PG&E	KELSO_2_UNITS	33813	MARIPCT1	13.8	49.51	1	Bay Area	Contra Costa	Aug NQC	Market
PG&E	KELSO_2_UNITS	33815	MARIPCT2	13.8	49.51	2	Bay Area	Contra Costa	Aug NQC	Market
PG&E	KELSO_2_UNITS	33817	MARIPCT3	13.8	49.51	3	Bay Area	Contra Costa	Aug NQC	Market
PG&E	KELSO_2_UNITS	33819	MARIPCT4	13.8	49.51	4	Bay Area	Contra Costa	Aug NQC	Market
PG&E	KIRKER_7_KELCYN				3.21		Bay Area	Pittsburg	Not modeled	Market
PG&E	LAWRNC_7_SUNYVL				0.18		Bay Area		Not modeled Aug NQC	Market
PG&E	LECEF_1_UNITS	35854	LECEFGT1	13.8	47.81	1	Bay Area	San Jose, South Bay-Moss Landing	Aug NQC	Market
PG&E	LECEF_1_UNITS	35855	LECEFGT2	13.8	47.81	1	Bay Area	San Jose, South Bay-Moss Landing	Aug NQC	Market
PG&E	LECEF_1_UNITS	35856	LECEFGT3	13.8	47.81	1	Bay Area	San Jose, South Bay-Moss Landing	Aug NQC	Market
PG&E	LECEF_1_UNITS	35857	LECEFGT4	13.8	47.81	1	Bay Area	San Jose, South Bay-Moss Landing	Aug NQC	Market
PG&E	LECEF_1_UNITS	35858	LECEFST1	13.8	114.75	1	Bay Area	San Jose, South Bay-Moss Landing		Market
PG&E	LMBEPK_2_UNITA1	32173	LAMBGT1	13.8	47.50	1	Bay Area	Contra Costa	Aug NQC	Market
PG&E	LMBEPK_2_UNITA2	32174	GOOSEHGT	13.8	47.60	2	Bay Area	Contra Costa	Aug NQC	Market
PG&E	LMBEPK_2_UNITA3	32175	CREEDGT1	13.8	47.40	3	Bay Area	Contra Costa	Aug NQC	Market
PG&E	LMEC_1_PL1X3	33111	LMECCT2	18	160.07	1	Bay Area	Pittsburg	Aug NQC	Market
PG&E	LMEC_1_PL1X3	33112	LMECCT1	18	160.07	1	Bay Area	Pittsburg	Aug NQC	Market
PG&E	LMEC_1_PL1X3	33113	LMECST1	18	235.85	1	Bay Area	Pittsburg	Aug NQC	Market
PG&E	MARTIN_1_SUNSET				1.85		Bay Area		Not modeled Aug NQC	QF/Selfgen
PG&E	METCLF_1_QF				0.22		Bay Area		Not modeled Aug NQC	QF/Selfgen
PG&E	METEC_2_PL1X3	35881	MEC CTG1	18	178.43	1	Bay Area	South Bay-Moss Landing	Aug NQC	Market
PG&E	METEC_2_PL1X3	35882	MEC CTG2	18	178.43	1	Bay Area	South Bay-Moss Landing	Aug NQC	Market
PG&E	METEC_2_PL1X3	35883	MEC STG1	18	213.13	1	Bay Area	South Bay-Moss Landing	Aug NQC	Market

Attachment A - List of physical resources by PTO, local area and market ID

PG&E	MISSIX_1_QF				0.01		Bay Area		Not modeled Aug NQC	QF/Selfgen
PG&E	MLPTAS_7_QFUNTS				0.01		Bay Area	San Jose, South Bay-Moss Landing	Not modeled Aug NQC	QF/Selfgen
PG&E	MOSSLD_1_QF				0.00		Bay Area		Not modeled Aug NQC	Market
PG&E	MOSSLD_2_PSP1	36221	DUKMOSS1	18	163.20	1	Bay Area	South Bay-Moss Landing	78% starting 2021	Market
PG&E	MOSSLD_2_PSP1	36222	DUKMOSS2	18	163.20	1	Bay Area	South Bay-Moss Landing	78% starting 2021	Market
PG&E	MOSSLD_2_PSP1	36223	DUKMOSS3	18	183.60	1	Bay Area	South Bay-Moss Landing	78% starting 2021	Market
PG&E	MOSSLD_2_PSP2	36224	DUKMOSS4	18	163.20	1	Bay Area	South Bay-Moss Landing	78% starting 2021	Market
PG&E	MOSSLD_2_PSP2	36225	DUKMOSS5	18	163.20	1	Bay Area	South Bay-Moss Landing	78% starting 2021	Market
PG&E	MOSSLD_2_PSP2	36226	DUKMOSS6	18	183.60	1	Bay Area	South Bay-Moss Landing	78% starting 2021	Market
PG&E	NEWARK_1_QF				0.29		Bay Area		Not modeled Aug NQC	QF/Selfgen
PG&E	OAK C_1_EBMUD				1.50		Bay Area	Oakland	Not modeled Aug NQC	MUNI
PG&E	OAK C_7_UNIT 1	32901	OAKLND 1	13.8	55.00	1	Bay Area	Oakland		Market
PG&E	OAK C_7_UNIT 2	32902	OAKLND 2	13.8	55.00	1	Bay Area	Oakland		Market
PG&E	OAK C_7_UNIT 3	32903	OAKLND 3	13.8	55.00	1	Bay Area	Oakland		Market
PG&E	OAK L_1_GTG1				0.00		Bay Area	Oakland	Not modeled Energy Only	Market
PG&E	OXMTN_6_LNDFIL	33469	OX_MTN	4.16	1.45	1	Bay Area	Ames		Market
PG&E	OXMTN_6_LNDFIL	33469	OX_MTN	4.16	1.45	2	Bay Area	Ames		Market
PG&E	OXMTN_6_LNDFIL	33469	OX_MTN	4.16	1.45	3	Bay Area	Ames		Market
PG&E	OXMTN_6_LNDFIL	33469	OX_MTN	4.16	1.45	4	Bay Area	Ames		Market
PG&E	OXMTN_6_LNDFIL	33469	OX_MTN	4.16	1.45	5	Bay Area	Ames		Market
PG&E	OXMTN_6_LNDFIL	33469	OX_MTN	4.16	1.45	6	Bay Area	Ames		Market
PG&E	OXMTN_6_LNDFIL	33469	OX_MTN	4.16	1.45	7	Bay Area	Ames		Market
PG&E	PALALT_7_COBUG				4.50		Bay Area		Not modeled	MUNI
PG&E	RICHMN_1_CHVSR2				3.48		Bay Area		Not modeled Aug NQC	Solar

Attachment A - List of physical resources by PTO, local area and market ID

PG&E	RICHMN_1_SOLAR				0.82		Bay Area		Not modeled Aug NQC	Solar
PG&E	RICHMN_7_BAYENV				2.00		Bay Area		Not modeled Aug NQC	Market
PG&E	RUSCTY_2_UNITS	35304	RUSELCT1	15	187.12	1	Bay Area	Ames	No NQC - Pmax	Market
PG&E	RUSCTY_2_UNITS	35305	RUSELCT2	15	187.12	2	Bay Area	Ames	No NQC - Pmax	Market
PG&E	RUSCTY_2_UNITS	35306	RUSELST1	15	246.26	3	Bay Area	Ames	No NQC - Pmax	Market
PG&E	RVRVEW_1_UNITA1	33178	RVEC_GEN	13.8	47.60	1	Bay Area	Contra Costa	Aug NQC	Market
PG&E	SRINTL_6_UNIT	33468	SRI INTL	9.11	0.81	1	Bay Area		Aug NQC	QF/Selfgen
PG&E	STAUFF_1_UNIT	33139	STAUFER	9.11	0.01	1	Bay Area		Aug NQC	QF/Selfgen
PG&E	STOILS_1_UNITS	32921	CHEVGEN1	13.8	1.08	1	Bay Area	Pittsburg	Aug NQC	Market
PG&E	STOILS_1_UNITS	32922	CHEVGEN2	13.8	1.08	1	Bay Area	Pittsburg	Aug NQC	Market
PG&E	STOILS_1_UNITS	32923	CHEVGEN3	13.8	0.50	3	Bay Area	Pittsburg	Aug NQC	Market
PG&E	TIDWTR_2_UNITS	33151	FOSTER W	12.4 7	4.02	1	Bay Area	Pittsburg	Aug NQC	Net Seller
PG&E	TIDWTR_2_UNITS	33151	FOSTER W	12.4 7	4.02	2	Bay Area	Pittsburg	Aug NQC	Net Seller
PG&E	TIDWTR_2_UNITS	33151	FOSTER W	12.4 7	3.06	3	Bay Area	Pittsburg	Aug NQC	Net Seller
PG&E	UNCHEM_1_UNIT	32920	UNION CH	9.11	12.44	1	Bay Area	Pittsburg	Aug NQC	QF/Selfgen
PG&E	UNOCAL_1_UNITS	32910	UNOCAL	12	0.01	1	Bay Area	Pittsburg	Aug NQC	QF/Selfgen
PG&E	UNOCAL_1_UNITS	32910	UNOCAL	12	0.01	2	Bay Area	Pittsburg	Aug NQC	QF/Selfgen
PG&E	UNOCAL_1_UNITS	32910	UNOCAL	12	0.01	3	Bay Area	Pittsburg	Aug NQC	QF/Selfgen
PG&E	USWNRD_2_SMUD	32169	SOLANOWP	21	27.08	1	Bay Area	Contra Costa	Aug NQC	Wind
PG&E	USWNRD_2_SMUD2	32186	SOLANO	34.5	33.87	1	Bay Area	Contra Costa	Aug NQC	Wind
PG&E	USWNRD_2_UNITS	32168	EXNCO	9.11	2.12	1	Bay Area	Contra Costa	Aug NQC	Wind
PG&E	USWPJR_2_UNITS	39233	GRNRDG	0.69	20.72	1	Bay Area	Contra Costa	Aug NQC	Wind
PG&E	WNDMAS_2_UNIT 1	33170	WINDMSTR	9.11	10.07	1	Bay Area	Contra Costa	Aug NQC	Wind
PG&E	ZOND_6_UNIT	35316	ZOND SYS	9.11	4.53	1	Bay Area	Contra Costa	Aug NQC	Wind
PG&E	ZZ_IBMCTL_1_UNIT 1	35637	IBM-CTLE	115	0.00	1	Bay Area	San Jose, South Bay-Moss Landing	No NQC - hist. data	Market
PG&E	ZZ_IMHOFF_1_UNIT 1	33136	CCCSD	12.4 7	0.00	1	Bay Area	Pittsburg	No NQC - hist. data	QF/Selfgen

Attachment A - List of physical resources by PTO, local area and market ID

PG&E	ZZ_MARKHM_1_CATLST	35863	CATALYST	9.11	0.00	1	Bay Area	San Jose, South Bay-Moss Landing		QF/Selfgen
PG&E	ZZ_NA	36209	SLD ENRG	12.47	0.00	1	Bay Area	South Bay-Moss Landing		QF/Selfgen
PG&E	ZZ_NA	35861	SJ-SCL W	4.3	0.00	1	Bay Area	San Jose, South Bay-Moss Landing	No NQC - hist. data	QF/Selfgen
PG&E	ZZ_SEAWST_6_LAPOS	35312	FOREBAYW	22.01	0.00	1	Bay Area	Contra Costa	No NQC - est. data	Wind
PG&E	ZZ_SHELRF_1_UNITS	33141	SHELL 1	12.47	0.00	1	Bay Area	Pittsburg	No NQC - hist. data	Net Seller
PG&E	ZZ_SHELRF_1_UNITS	33142	SHELL 2	12.47	0.00	1	Bay Area	Pittsburg	No NQC - hist. data	Net Seller
PG&E	ZZ_SHELRF_1_UNITS	33143	SHELL 3	12.47	0.00	1	Bay Area	Pittsburg	No NQC - hist. data	Net Seller
PG&E	ZZ_USWPFK_6_FRICK	35320	FRICKWND	12	1.90	1	Bay Area	Contra Costa	Aug NQC	Wind
PG&E	ZZ_USWPFK_6_FRICK	35320	FRICKWND	12	0.00	2	Bay Area	Contra Costa	Aug NQC	Wind
PG&E	ZZ_ZANKER_1_UNIT 1	35861	SJ-SCL W	4.3	0.00	RN	Bay Area	San Jose, South Bay-Moss Landing	No NQC - hist. data	QF/Selfgen
PG&E	ZZZ_New Unit	35623	SWIFT	21	4.00	BT	Bay Area	San Jose, South Bay-Moss Landing	No NQC - Pmax	Battery
PG&E	ZZZ_New Unit	30522	0354-WD	21	1.83	EW	Bay Area	Contra Costa	No NQC - Pmax	Market
PG&E	ZZZ_New Unit	35302	NUMMI-LV	12.56	0.00	RN	Bay Area		Energy Only	Market
PG&E	ZZZ_New Unit	35859	HGST-LV	12.41	0.00	RN	Bay Area		Energy Only	Market
PG&E	ZZZ_New Unit	35307	A100US-L	12.56	0.00	RN	Bay Area		Energy Only	Market
PG&E	ZZZZZ_COCOPP_7_UNIT 6	33116	C.COS 6	18	0.00	RT	Bay Area	Contra Costa	Retired	Market
PG&E	ZZZZZ_COCOPP_7_UNIT 7	33117	C.COS 7	18	0.00	RT	Bay Area	Contra Costa	Retired	Market
PG&E	ZZZZZ_CONTAN_1_UNIT	36856	CCA100	13.8	0.00	1	Bay Area	San Jose, South Bay-Moss Landing	Retired	MUNI
PG&E	ZZZZZ_FLOWD1_6_ALTP P1	35318	FLOWDPTR	9.11	0.00	1	Bay Area	Contra Costa	Retired	Wind
PG&E	ZZZZZ_LFC 51_2_UNIT 1	35310	PPASSWND	21	0.00	1	Bay Area		Retired	Wind
PG&E	ZZZZZ_MOSSLD_7_UNIT 6	36405	MOSSLND6	22	0.00	1	Bay Area	South Bay-Moss Landing	Retired	Market

Attachment A - List of physical resources by PTO, local area and market ID

PG&E	ZZZZZ_MOSSLD_7_UNIT 7	36406	MOSSLND7	22	0.00	1	Bay Area	South Bay-Moss Landing	Retired	Market
PG&E	ZZZZZ_PITTSP_7_UNIT 5	33105	PTSB 5	18	0.00	RT	Bay Area	Pittsburg	Retired	Market
PG&E	ZZZZZ_PITTSP_7_UNIT 6	33106	PTSB 6	18	0.00	RT	Bay Area	Pittsburg	Retired	Market
PG&E	ZZZZZ_PITTSP_7_UNIT 7	30000	PTSB 7	20	0.00	RT	Bay Area	Pittsburg	Retired	Market
PG&E	ZZZZZ_UNTDQF_7_UNIT S	33466	UNTED CO	9.11	0.00	1	Bay Area		Retired	QF/Selfgen
PG&E	ADERA_1_SOLAR1	34319	Q644	0.48	0.00	1	Fresno	Herndon	Aug NQC	Solar
PG&E	ADMEST_6_SOLAR	34315	ADAMS_E	12.47	0.00	1	Fresno	Herndon	Energy Only	Solar
PG&E	AGRICO_6_PL3N5	34608	AGRICO	13.8	22.69	3	Fresno	Herndon		Market
PG&E	AGRICO_7_UNIT	34608	AGRICO	13.8	7.47	2	Fresno	Herndon		Market
PG&E	AGRICO_7_UNIT	34608	AGRICO	13.8	43.13	4	Fresno	Herndon		Market
PG&E	AVENAL_6_AVPARK	34265	AVENAL P	12	2.46	1	Fresno	Coalinga	Aug NQC	Solar
PG&E	AVENAL_6_AVSLR1	34691	AVENAL_1	21	0.00	EW	Fresno	Coalinga	Energy Only	Solar
PG&E	AVENAL_6_AVSLR2	34691	AVENAL_1	21	0.00	EW	Fresno	Coalinga	Energy Only	Solar
PG&E	AVENAL_6_SANDDG	34263	SANDDRAG	12	6.54	1	Fresno	Coalinga	Aug NQC	Solar
PG&E	AVENAL_6_SUNCTY	34257	SUNCTY D	12	8.20	1	Fresno	Coalinga	Aug NQC	Solar
PG&E	BALCHS_7_UNIT 1	34624	BALCH	13.2	33.00	1	Fresno	Herndon	Aug NQC	Market
PG&E	BALCHS_7_UNIT 2	34612	BLCH	13.8	52.50	1	Fresno	Herndon	Aug NQC	Market
PG&E	BALCHS_7_UNIT 3	34614	BLCH	13.8	54.60	1	Fresno	Herndon	Aug NQC	Market
PG&E	CANTUA_1_SOLAR	34349	CANTUA_D	12.47	4.10	1	Fresno		Aug NQC	Solar
PG&E	CANTUA_1_SOLAR	34349	CANTUA_D	12.47	4.10	2	Fresno		Aug NQC	Solar
PG&E	CHEVCO_6_UNIT 1	34652	CHV.COAL	9.11	1.94	1	Fresno	Coalinga	Aug NQC	QF/Selfgen
PG&E	CHEVCO_6_UNIT 2	34652	CHV.COAL	9.11	0.92	2	Fresno	Coalinga	Aug NQC	QF/Selfgen
PG&E	CHWCHL_1_BIOMAS	34305	CHWCHLA2	13.8	9.66	1	Fresno	Herndon	Aug NQC	Market
PG&E	CHWCHL_1_UNIT	34301	CHOWCOGN	13.8	48.00	1	Fresno	Herndon		Market
PG&E	COLGA1_6_SHELLW	34654	COLNGAGN	9.11	34.70	1	Fresno	Coalinga	Mothballed	Net Seller
PG&E	CORCAN_1_SOLAR1	34690	CORCORAN	12.47	8.20	FW	Fresno	Herndon, Hanford	Aug NQC	Solar
PG&E	CORCAN_1_SOLAR2	34692	CORCORAN	12.47	4.51	FW	Fresno	Herndon, Hanford	Aug NQC	Solar

Attachment A - List of physical resources by PTO, local area and market ID

PG&E	CRESSY_1_PARKER	34140	CRESSEY	115	0.84		Fresno		Not modeled Aug NQC	MUNI
PG&E	CRNEVL_6_CRNVA	34634	CRANEVLY	12	0.00	1	Fresno	Borden	Aug NQC	Market
PG&E	CRNEVL_6_SJQN 2	34631	SJ2GEN	9.11	0.00	1	Fresno	Borden	Aug NQC	Market
PG&E	CRNEVL_6_SJQN 3	34633	SJ3GEN	9.11	0.00	1	Fresno	Borden	Aug NQC	Market
PG&E	CURTIS_1_CANLCK				0.00		Fresno		Not modeled Aug NQC	Market
PG&E	CURTIS_1_FARFLD				0.29		Fresno		Not modeled Aug NQC	Market
PG&E	DINUBA_6_UNIT	34648	DINUBA E	13.8	2.58	1	Fresno	Herndon, Reedley		Market
PG&E	EEKTMN_6_SOLAR1	34629	KETTLEMN	0.8	0.00	1	Fresno		Energy Only	Solar
PG&E	ELCAP_1_SOLAR				0.62		Fresno		Not Modeled Aug NQC	Solar
PG&E	ELNIDP_6_BIOMAS	34330	ELNIDO	13.8	9.84	1	Fresno		Aug NQC	Market
PG&E	EXCHEC_7_UNIT 1	34306	EXCHQUER	13.8	90.72	1	Fresno		Aug NQC	MUNI
PG&E	EXCLSG_1_SOLAR	34623	Q678	0.5	24.60	1	Fresno		Aug NQC	Solar
PG&E	FRESHW_1_SOLAR1	34699	Q529	0.38 5	0.00	1	Fresno	Herndon	Energy Only	Solar
PG&E	FRIANT_6_UNITS	34636	FRIANTDM	6.6	10.04	2	Fresno	Borden	Aug NQC	Net Seller
PG&E	FRIANT_6_UNITS	34636	FRIANTDM	6.6	5.36	3	Fresno	Borden	Aug NQC	Net Seller
PG&E	FRIANT_6_UNITS	34636	FRIANTDM	6.6	1.42	4	Fresno	Borden	Aug NQC	Net Seller
PG&E	GIFENS_6_BUGSL1	34644	Q679	0.55	8.20	1	Fresno		Aug NQC	Solar
PG&E	GIFFEN_6_SOLAR	34467	GIFFEN_DIST	12.4 7	4.10	1	Fresno	Herndon	Aug NQC	Solar
PG&E	GUERNS_6_SOLAR	34463	GUERNSEY_ D2	12.4 7	4.10	5	Fresno		Aug NQC	Solar
PG&E	GUERNS_6_SOLAR	34461	GUERNSEY_ D1	12.4 7	4.10	8	Fresno		Aug NQC	Solar
PG&E	GWFPWR_1_UNITS	34431	GWF_HEP1	13.8	49.23	1	Fresno	Herndon, Hanford		Market
PG&E	GWFPWR_1_UNITS	34433	GWF_HEP2	13.8	49.23	1	Fresno	Herndon, Hanford		Market
PG&E	HAASPH_7_PL1X2	34610	HAAS	13.8	72.00	1	Fresno	Herndon	Aug NQC	Market
PG&E	HAASPH_7_PL1X2	34610	HAAS	13.8	72.00	2	Fresno	Herndon	Aug NQC	Market
PG&E	HELMPG_7_UNIT 1	34600	HELMS	18	407.00	1	Fresno		Aug NQC	Market
PG&E	HELMPG_7_UNIT 2	34602	HELMS	18	407.00	2	Fresno		Aug NQC	Market
PG&E	HELMPG_7_UNIT 3	34604	HELMS	18	404.00	3	Fresno		Aug NQC	Market
PG&E	HENRTA_6_SOLAR1				0.62		Fresno		Not modeled Aug NQC	Solar

Attachment A - List of physical resources by PTO, local area and market ID

PG&E	HENRTA_6_SOLAR2				0.00		Fresno		Not modeled Energy Only	Solar
PG&E	HENRTA_6_UNITA1	34539	GWF_GT1	13.8	49.98	1	Fresno			Market
PG&E	HENRTA_6_UNITA2	34541	GWF_GT2	13.8	49.42	1	Fresno			Market
PG&E	HENRTS_1_SOLAR	34617	Q581	0.38	41.00	1	Fresno		Aug NQC	Solar
PG&E	HURON_6_SOLAR	34557	HURON_DI	12.4 7	4.10	1	Fresno	Coalinga	Aug NQC	Solar
PG&E	HURON_6_SOLAR	34557	HURON_DI	12.4 7	4.10	2	Fresno	Coalinga	Aug NQC	Solar
PG&E	JAYNE_6_WLSLR	34639	WESTLNDS	0.48	0.00	1	Fresno	Coalinga	Energy Only	Solar
PG&E	KANSAS_6_SOLAR	34666	KANSASS_S	12.4 7	0.00	F	Fresno		Energy Only	Solar
PG&E	KERKH1_7_UNIT 1	34344	KERCK1-1	6.6	13.00	1	Fresno	Herndon	Aug NQC	Market
PG&E	KERKH1_7_UNIT 3	34345	KERCK1-3	6.6	12.80	3	Fresno	Herndon	Aug NQC	Market
PG&E	KERKH2_7_UNIT 1	34308	KERCKHOF	13.8	153.90	1	Fresno	Herndon	Aug NQC	Market
PG&E	KERMAN_6_SOLAR1				0.00		Fresno		Not modeled Energy Only	Solar
PG&E	KERMAN_6_SOLAR2				0.00		Fresno		Not modeled Energy Only	Solar
PG&E	KINGCO_1_KINGBR	34642	KINGSBUR	9.11	34.50	1	Fresno	Herndon, Hanford	Aug NQC	Net Seller
PG&E	KINGRV_7_UNIT 1	34616	KINGSRIV	13.8	51.20	1	Fresno	Herndon, Reedley	Aug NQC	Market
PG&E	KNGBRG_1_KBSLR1				0.00		Fresno		Not modeled Energy Only	Solar
PG&E	KNGBRG_1_KBSLR2				0.00		Fresno		Not modeled Energy Only	Solar
PG&E	KNTSTH_6_SOLAR	34694	KENT_S	0.8	0.00	1	Fresno		Energy Only	Solar
PG&E	LEPRFD_1_KANSAS	34680	KANSAS	12.4 7	8.20	1	Fresno	Hanford	Aug NQC	Solar
PG&E	MALAGA_1_PL1X2	34671	KRCDPCT1	13.8	48.00	1	Fresno	Herndon		Market
PG&E	MALAGA_1_PL1X2	34672	KRCDPCT2	13.8	48.00	1	Fresno	Herndon		Market
PG&E	MCCALL_1_QF	34219	MCCALL 4	12.4 7	0.48	QF	Fresno	Herndon	Aug NQC	QF/Selfgen
PG&E	MCSWAN_6_UNITS	34320	MCSWAIN	9.11	9.60	1	Fresno		Aug NQC	MUNI
PG&E	MENBIO_6_RENEW1	34339	CALRENEW	12.5	2.05	1	Fresno	Herndon	Aug NQC	Net Seller
PG&E	MENBIO_6_UNIT	34334	BIO PWR	9.11	19.24	1	Fresno		Aug NQC	QF/Selfgen
PG&E	MERCED_1_SOLAR1				0.00		Fresno		Not modeled Energy Only	Solar

Attachment A - List of physical resources by PTO, local area and market ID

PG&E	MERCED_1_SOLAR2				0.00		Fresno		Not modeled Energy Only	Solar
PG&E	MERCFL_6_UNIT	34322	MERCEDFL	9.11	3.36	1	Fresno		Aug NQC	Market
PG&E	MNDOTA_1_SOLAR1	34313	NORTHSTAR	0.2	24.60	1	Fresno		Aug NQC	Solar
PG&E	MNDOTA_1_SOLAR2				0.00		Fresno		Not modeled Energy Only	Solar
PG&E	MSTANG_2_SOLAR	34683	Q643W	0.8	12.30	1	Fresno		Aug NQC	Solar
PG&E	MSTANG_2_SOLAR3	34683	Q643W	0.8	16.40	1	Fresno		Aug NQC	Solar
PG&E	MSTANG_2_SOLAR4	34683	Q643W	0.8	12.30	1	Fresno		Aug NQC	Solar
PG&E	ONLLPP_6_UNITS	34316	ONEILPMP	9.11	18.11	1	Fresno		Aug NQC	MUNI
PG&E	OROLOM_1_SOLAR1	34689	ORO LOMA_3	12.4 7	0.00	EW	Fresno		Energy Only	Solar
PG&E	OROLOM_1_SOLAR2	34689	ORO LOMA_3	12.4 7	0.00	EW	Fresno		Energy Only	Solar
PG&E	ORTGA_6_ME1SL1				0.00		Fresno		Not modeled Energy Only	Solar
PG&E	PAIGES_6_SOLAR	34653	Q526	0.55	0.00	1	Fresno	Coalinga	Energy Only	Solar
PG&E	PINFLT_7_UNITS	38720	PINEFLAT	13.8	26.55	1	Fresno	Herndon	Aug NQC	MUNI
PG&E	PINFLT_7_UNITS	38720	PINEFLAT	13.8	26.55	2	Fresno	Herndon	Aug NQC	MUNI
PG&E	PINFLT_7_UNITS	38720	PINEFLAT	13.8	26.55	3	Fresno	Herndon	Aug NQC	MUNI
PG&E	PNCHPP_1_PL1X2	34328	STARGT1	13.8	59.96	1	Fresno			Market
PG&E	PNCHPP_1_PL1X2	34329	STARGT2	13.8	59.96	2	Fresno			Market
PG&E	PNOCHE_1_PL1X2	34142	WHD_PAN2	13.8	49.97	1	Fresno	Herndon		Market
PG&E	PNOCHE_1_UNITA1	34186	DG_PAN1	13.8	48.00	1	Fresno			Market
PG&E	REEDLY_6_SOLAR				0.00		Fresno	Herndon, Reedley	Not modeled Energy Only	Solar
PG&E	S_RITA_6_SOLAR1				0.00		Fresno		Not modeled Energy Only	Solar
PG&E	SCHNDR_1_FIVPTS	34353	SCHINDLER_D	12.4 7	4.10	1	Fresno	Coalinga	Aug NQC	Solar
PG&E	SCHNDR_1_FIVPTS	34353	SCHINDLER_D	12.4 7	2.05	2	Fresno	Coalinga	Aug NQC	Solar
PG&E	SCHNDR_1_WSTSDE	34353	SCHINDLER_D	12.4 7	4.10	3	Fresno	Coalinga	Aug NQC	Solar
PG&E	SCHNDR_1_WSTSDE	34353	SCHINDLER_D	12.4 7	2.05	4	Fresno	Coalinga	Aug NQC	Solar
PG&E	SGREGY_6_SANGER	34646	SANGERCO	13.8	38.77	1	Fresno		Aug NQC	Market
PG&E	SGREGY_6_SANGER	34646	SANGERCO	13.8	9.31	2	Fresno		Aug NQC	Market

Attachment A - List of physical resources by PTO, local area and market ID

PG&E	STOREY_2_MDRCH2	34253	BORDEN D	12.4 7	0.34		Fresno		Not modeled Aug NQC	Market
PG&E	STOREY_2_MDRCH3	34253	BORDEN D	12.4 7	0.23		Fresno		Not modeled Aug NQC	Market
PG&E	STOREY_2_MDRCH4	34253	BORDEN D	12.4 7	0.42		Fresno		Not modeled Aug NQC	Market
PG&E	STOREY_7_MDRCHW	34209	STOREY D	12.4 7	0.66	1	Fresno		Aug NQC	Net Seller
PG&E	STROUD_6_SOLAR	34563	STROUD_D	12.4 7	4.10	1	Fresno	Herndon	Aug NQC	Solar
PG&E	STROUD_6_SOLAR	34563	STROUD_D	12.4 7	4.10	2	Fresno	Herndon	Aug NQC	Solar
PG&E	TRNQL8_2_AMASR1	36551 4	Q1032G1	0.55	8.20	1	Fresno		Aug NQC	Solar
PG&E	TRNQL8_2_AZUSR1	36551 7	Q1032G2	0.55	8.20	2	Fresno		Aug NQC	Solar
PG&E	TRNQL8_2_ROJSR1	36552 0	Q1032G3	0.55	15.58	3	Fresno		Aug NQC	Solar
PG&E	TRNQL8_2_VERSR1	36552 0	Q1032G3	0.55	0.00	3	Fresno		Aug NQC	Solar
PG&E	TRNQLT_2_SOLAR	34340	Q643X	0.8	82.00	1	Fresno		Aug NQC	Solar
PG&E	ULTPFR_1_UNIT 1	34640	ULTR.PWR	9.11	24.07	1	Fresno	Herndon	Aug NQC	Market
PG&E	VEGA_6_SOLAR1	34314	VEGA	34.5	0.00	1	Fresno		Energy Only	Solar
PG&E	WAUKNA_1_SOLAR	34696	CORCORANP V_S	21	8.20	1	Fresno	Herndon, Hanford	Aug NQC	Solar
PG&E	WAUKNA_1_SOLAR2	34677	Q558	21	8.10	1	Fresno	Herndon, Hanford	No NQC - Pmax	Solar
PG&E	WFRESN_1_SOLAR				0.00		Fresno		Not modeled Energy Only	Solar
PG&E	WHITNY_6_SOLAR	34673	Q532	0.55	0.00	1	Fresno	Coalinga	Energy Only	Solar
PG&E	WISHON_6_UNITS	34658	WISHON	2.3	4.51	1	Fresno	Borden	Aug NQC	Market
PG&E	WISHON_6_UNITS	34658	WISHON	2.3	4.51	2	Fresno	Borden	Aug NQC	Market
PG&E	WISHON_6_UNITS	34658	WISHON	2.3	4.51	3	Fresno	Borden	Aug NQC	Market
PG&E	WISHON_6_UNITS	34658	WISHON	2.3	4.51	4	Fresno	Borden	Aug NQC	Market
PG&E	WISHON_6_UNITS	34658	WISHON	2.3	0.36	SJ	Fresno	Borden	Aug NQC	Market
PG&E	WOODWR_1_HYDRO				0.00		Fresno		Not modeled Energy Only	Market
PG&E	WRGHTP_7_AMENGY	34207	WRIGHT D	12.4 7	0.28	QF	Fresno		Aug NQC	QF/Selfgen

Attachment A - List of physical resources by PTO, local area and market ID

PG&E	ZZ_BORDEN_2_QF	34253	BORDEN D	12.4 7	1.30	QF	Fresno		No NQC - hist. data	Net Seller
PG&E	ZZ_BULLRD_7_SAGNES	34213	BULLD 12	12.4 7	0.06	1	Fresno		Aug NQC	QF/Selfgen
PG&E	ZZ_JRWOOD_1_UNIT 1	34332	JRWCOGEN	9.11	0.00	1	Fresno			QF/Selfgen
PG&E	ZZ_KERKH1_7_UNIT 2	34343	KERCK1-2	6.6	8.50	2	Fresno	Herndon	No NQC - hist. data	Market
PG&E	ZZ_NA	34485	FRESNOWW	12.5	0.00	1	Fresno		No NQC - hist. data	QF/Selfgen
PG&E	ZZ_NA	34485	FRESNOWW	12.5	0.10	2	Fresno		No NQC - hist. data	QF/Selfgen
PG&E	ZZ_NA	34485	FRESNOWW	12.5	0.00	3	Fresno		No NQC - hist. data	QF/Selfgen
PG&E	ZZ_New Unit	34651	JACALITO-LV	0.55	1.22	RN	Fresno		No NQC - Pmax	Market
PG&E	ZZZ_New Unit	34649	Q965	0.36	5.53	1	Fresno	Herndon	No NQC - est. data	Solar
PG&E	ZZZ_New Unit	36550 2	Q632BC1	0.55	8.28	1	Fresno		No NQC - est. data	Solar
PG&E	ZZZ_New Unit	34603	JGBSWLT	12.4 7	0.00	ST	Fresno	Herndon	Energy Only	Market
PG&E	ZZZZ_CAPMAD_1_UNIT 1	34179	MADERA_G	13.8	0.00	RT	Fresno		Retired	Market
PG&E	ZZZZ_GATES_6_PL1X2	34553	WHD_GAT2	13.8	0.00	RT	Fresno	Coalinga	Retired	Market
PG&E	ZZZZ_INTTRB_6_UNIT	34342	INT.TURB	9.11	0.00	1	Fresno		Aug NQC	Market
PG&E	BRDGV_L_7_BAKER				0.00		Humboldt		Not modeled Aug NQC	Net Seller
PG&E	FAIRHV_6_UNIT	31150	FAIRHAVN	13.8	13.58	1	Humboldt		Aug NQC	Net Seller
PG&E	FTSWRD_6_TRFORK				0.16		Humboldt		Not modeled Aug NQC	Market
PG&E	FTSWRD_7_QFUNTS				0.00		Humboldt		Not modeled Aug NQC	QF/Selfgen
PG&E	GRSCRK_6_BGCKWW				0.00		Humboldt		Not modeled Aug NQC	Market
PG&E	HUMBPP_1_UNITS3	31180	HUMB_G1	13.8	16.32	1	Humboldt			Market
PG&E	HUMBPP_1_UNITS3	31180	HUMB_G1	13.8	15.85	2	Humboldt			Market
PG&E	HUMBPP_1_UNITS3	31180	HUMB_G1	13.8	16.69	3	Humboldt			Market
PG&E	HUMBPP_1_UNITS3	31180	HUMB_G1	13.8	16.22	4	Humboldt			Market

Attachment A - List of physical resources by PTO, local area and market ID

PG&E	HUMBPP_6_UNITS	31181	HUMB_G2	13.8	16.14	5	Humboldt			Market
PG&E	HUMBPP_6_UNITS	31181	HUMB_G2	13.8	16.33	6	Humboldt			Market
PG&E	HUMBPP_6_UNITS	31181	HUMB_G2	13.8	16.24	7	Humboldt			Market
PG&E	HUMBPP_6_UNITS	31182	HUMB_G3	13.8	16.62	8	Humboldt			Market
PG&E	HUMBPP_6_UNITS	31182	HUMB_G3	13.8	16.33	9	Humboldt			Market
PG&E	HUMBPP_6_UNITS	31182	HUMB_G3	13.8	15.95	10	Humboldt			Market
PG&E	HUMBSB_1_QF				0.00		Humboldt		Not modeled Aug NQC	QF/Selfgen
PG&E	KEKAWK_6_UNIT	31166	KEKAWAK	9.1	0.00	1	Humboldt		Aug NQC	Net Seller
PG&E	LAPAC_6_UNIT	31158	LP SAMOA	12.5	0.00	1	Humboldt			Market
PG&E	LOWGAP_1_SUPHR				0.00		Humboldt		Not modeled Aug NQC	Market
PG&E	PACLUM_6_UNIT	31152	PAC.LUMB	13.8	7.88	1	Humboldt		Aug NQC	Net Seller
PG&E	PACLUM_6_UNIT	31152	PAC.LUMB	13.8	7.88	2	Humboldt		Aug NQC	Net Seller
PG&E	PACLUM_6_UNIT	31153	PAC.LUMB	2.4	4.73	3	Humboldt		Aug NQC	Net Seller
PG&E	ZZZZ_BULKE_6_BLUEL K	31156	BLUELKPP	12.5	0.00	1	Humboldt		Retired	Market
PG&E	7STDRD_1_SOLAR1	35065	7STNDRD_1	21	8.20	FW	Kern	South Kern PP, Kern Oil	Aug NQC	Solar
PG&E	ADOBEE_1_SOLAR	35021	Q622B	34.5	8.20	1	Kern	South Kern PP	Aug NQC	Solar
PG&E	BDGRCK_1_UNITS	35029	BADGERCK	13.8	42.90	1	Kern	South Kern PP	Aug NQC	Net Seller
PG&E	BEARMT_1_UNIT	35066	PSE-BEAR	13.8	46.60	1	Kern	South Kern PP, Westpark	Aug NQC	Net Seller
PG&E	BKRFLD_2_SOLAR1				0.57		Kern	South Kern PP	Not modeled Aug NQC	Solar
PG&E	DEXZEL_1_UNIT	35024	DEXEL +	13.8	11.98	1	Kern	South Kern PP, Kern Oil	Aug NQC	Net Seller
PG&E	DISCOV_1_CHEVRN	35062	DISCOVERY	13.8	3.53	1	Kern	South Kern PP, Kern Oil	Aug NQC	QF/Selfgen
PG&E	DOUBLC_1_UNITS	35023	DOUBLE C	13.8	52.23	1	Kern	South Kern PP	Aug NQC	Net Seller
PG&E	KERNFT_1_UNITS	35026	KERNFRNT	9.11	52.40	1	Kern	South Kern PP	Aug NQC	Net Seller
PG&E	LAMONT_1_SOLAR1	35019	REGULUS	0.4	24.60	1	Kern	South Kern PP	Aug NQC	Solar
PG&E	LAMONT_1_SOLAR2	35092	Q744G4	0.38	8.20	1	Kern	South Kern PP	Aug NQC	Solar
PG&E	LAMONT_1_SOLAR3	35087	Q744G3	0.4	6.15	3	Kern	South Kern PP	Aug NQC	Solar
PG&E	LAMONT_1_SOLAR4	35059	Q744G2	0.4	17.26	2	Kern	South Kern PP	Aug NQC	Solar
PG&E	LAMONT_1_SOLAR5	35054	Q744G1	0.4	6.83	1	Kern	South Kern PP	Aug NQC	Solar

Attachment A - List of physical resources by PTO, local area and market ID

PG&E	LIVOAK_1_UNIT 1	35058	PSE-LVOK	9.1	44.90	1	Kern	South Kern PP, Kern Oil	Aug NQC	Net Seller
PG&E	MAGUND_1_BKISR1				0.41		Kern	South Kern PP, Kern Oil	Not modeled Aug NQC	Solar
PG&E	MAGUND_1_BKSSR2				2.15		Kern	South Kern PP, Kern Oil	Not modeled Aug NQC	Solar
PG&E	MTNPOS_1_UNIT	35036	MT POSO	13.8	46.64	1	Kern	South Kern PP, Kern Oil	Aug NQC	Net Seller
PG&E	OLDRIV_6_BIOGAS				1.70		Kern	South Kern PP, Kern 70 kV	Not modeled Aug NQC	Market
PG&E	OLDRIV_6_CESDBM				0.94		Kern	South Kern PP, Kern 70 kV	Not modeled Aug NQC	Market
PG&E	OLDRIV_6_LKVBM1				0.94		Kern	South Kern PP, Kern 70 kV	Not modeled Aug NQC	Market
PG&E	OLDRV1_6_SOLAR	35091	OLD_RVR1	12.5	8.20	1	Kern	South Kern PP, Kern 70 kV	Aug NQC	Solar
PG&E	SIERRA_1_UNITS	35027	HISIERRA	9.11	52.43	1	Kern	South Kern PP	Aug NQC	Market
PG&E	SKERN_6_SOLAR1	35089	S_KERN	0.48	8.20	1	Kern	South Kern PP, Kern 70 kV	Aug NQC	Solar
PG&E	SKERN_6_SOLAR2	36556 3	Q885	0.36	4.10	1	Kern	South Kern PP, Kern 70 kV	Aug NQC	Solar
PG&E	VEDDER_1_SEKERN	35046	SEKR	9.11	4.31	1	Kern	South Kern PP, Kern Oil	Aug NQC	QF/Selfgen
PG&E	ZZZZ_KRNCNY_6_UNIT	35018	KERNCNYN	11	0.00	1	Kern	South Kern PP, Kern 70 kV	Aug NQC	Market
PG&E	ZZZZ_OILDAL_1_UNIT 1	35028	OILDALE	9.11	0.00	RT	Kern	South Kern PP, Kern Oil	Retired	Net Seller
PG&E	ZZZZ_RIOBRV_6_UNIT 1	35020	RIOBRAVO	9.1	0.00	1	Kern	South Kern PP, Kern 70 kV	Aug NQC	Market
PG&E	ZZZZ_ULTOGL_1_POSO	35035	ULTR PWR	9.11	0.00	1	Kern	South Kern PP, Kern Oil	Retired	QF/Selfgen
PG&E	ADLIN_1_UNITS	31435	GEO.ENGY	9.1	8.00	1	NCNB	Eagle Rock, Fulton		Market
PG&E	ADLIN_1_UNITS	31435	GEO.ENGY	9.1	8.00	2	NCNB	Eagle Rock, Fulton		Market
PG&E	CLOVDL_1_SOLAR				0.62		NCNB	Eagle Rock, Fulton	Not modeled Aug NQC	Solar
PG&E	CSTOGA_6_LNDFIL				0.00		NCNB	Fulton	Not modeled Energy Only	Market

Attachment A - List of physical resources by PTO, local area and market ID

PG&E	FULTON_1_QF				0.05		NCNB	Fulton	Not modeled Aug NQC	QF/Selfgen
PG&E	GEYS11_7_UNIT11	31412	GEYSER11	13.8	68.00	1	NCNB	Eagle Rock, Fulton		Market
PG&E	GEYS12_7_UNIT12	31414	GEYSER12	13.8	50.00	1	NCNB	Fulton		Market
PG&E	GEYS13_7_UNIT13	31416	GEYSER13	13.8	56.00	1	NCNB			Market
PG&E	GEYS14_7_UNIT14	31418	GEYSER14	13.8	50.00	1	NCNB	Fulton		Market
PG&E	GEYS16_7_UNIT16	31420	GEYSER16	13.8	49.00	1	NCNB	Fulton		Market
PG&E	GEYS17_7_UNIT17	31422	GEYSER17	13.8	56.00	1	NCNB	Fulton		Market
PG&E	GEYS18_7_UNIT18	31424	GEYSER18	13.8	45.00	1	NCNB			Market
PG&E	GEYS20_7_UNIT20	31426	GEYSER20	13.8	40.00	1	NCNB			Market
PG&E	GYS5X6_7_UNITS	31406	GEYSR5-6	13.8	42.50	1	NCNB	Eagle Rock, Fulton		Market
PG&E	GYS5X6_7_UNITS	31406	GEYSR5-6	13.8	42.50	2	NCNB	Eagle Rock, Fulton		Market
PG&E	GYS7X8_7_UNITS	31408	GEYSER78	13.8	38.00	1	NCNB	Eagle Rock, Fulton		Market
PG&E	GYS7X8_7_UNITS	31408	GEYSER78	13.8	38.00	2	NCNB	Eagle Rock, Fulton		Market
PG&E	GYSRVL_7_WSPRNG				0.87		NCNB	Fulton	Not modeled Aug NQC	QF/Selfgen
PG&E	HILAND_7_YOLOWD				0.00		NCNB	Eagle Rock, Fulton	Not Modeled. Energy Only	Market
PG&E	IGNACO_1_QF				0.13		NCNB		Not modeled Aug NQC	QF/Selfgen
PG&E	INDVLY_1_UNITS	31436	INDIAN V	9.1	0.79	1	NCNB	Eagle Rock, Fulton	Aug NQC	Net Seller
PG&E	MONTPH_7_UNITS	32700	MONTICLO	9.1	3.02	1	NCNB	Fulton	Aug NQC	Market
PG&E	MONTPH_7_UNITS	32700	MONTICLO	9.1	3.02	2	NCNB	Fulton	Aug NQC	Market
PG&E	MONTPH_7_UNITS	32700	MONTICLO	9.1	0.91	3	NCNB	Fulton	Aug NQC	Market
PG&E	NCPA_7_GP1UN1	38106	NCPA1GY1	13.8	31.00	1	NCNB		Aug NQC	MUNI
PG&E	NCPA_7_GP1UN2	38108	NCPA1GY2	13.8	28.00	1	NCNB		Aug NQC	MUNI
PG&E	NCPA_7_GP2UN3	38110	NCPA2GY1	13.8	0.00	1	NCNB	Fulton	Aug NQC	MUNI
PG&E	NCPA_7_GP2UN4	38112	NCPA2GY2	13.8	52.73	1	NCNB	Fulton	Aug NQC	MUNI
PG&E	NOVATO_6_LNDFL				3.67		NCNB		Not modeled Aug NQC	Market
PG&E	POTTER_6_UNITS	31433	POTTRVLY	2.4	1.25	1	NCNB	Eagle Rock, Fulton	Aug NQC	Market

Attachment A - List of physical resources by PTO, local area and market ID

PG&E	POTTER_6_UNITS	31433	POTTRVLY	2.4	0.57	3	NCNB	Eagle Rock, Fulton	Aug NQC	Market
PG&E	POTTER_6_UNITS	31433	POTTRVLY	2.4	0.57	4	NCNB	Eagle Rock, Fulton	Aug NQC	Market
PG&E	POTTER_7_VECINO				0.01		NCNB	Eagle Rock, Fulton	Not modeled Aug NQC	QF/Selfgen
PG&E	SANTFG_7_UNITS	31400	SANTA FE	13.8	31.50	1	NCNB			Market
PG&E	SANTFG_7_UNITS	31400	SANTA FE	13.8	31.50	2	NCNB			Market
PG&E	SMUDGO_7_UNIT 1	31430	SMUDGE01	13.8	47.00	1	NCNB			Market
PG&E	SNMALF_6_UNITS	31446	SONMA LF	9.1	3.56	1	NCNB	Fulton	Aug NQC	QF/Selfgen
PG&E	UKIAH_7_LAKEMN	38020	CITY UKH	115	0.49	1	NCNB	Eagle Rock, Fulton	Aug NQC	MUNI
PG&E	UKIAH_7_LAKEMN	38020	CITY UKH	115	1.21	2	NCNB	Eagle Rock, Fulton	Aug NQC	MUNI
PG&E	ZZZZ_BEARN_2_UNITS	31402	BEAR CAN	13.8	0.00	1	NCNB	Fulton	Retired	Market
PG&E	ZZZZ_BEARN_2_UNITS	31402	BEAR CAN	13.8	0.00	2	NCNB	Fulton	Retired	Market
PG&E	ZZZZ_WDFRDF_2_UNIT S	31404	WEST FOR	13.8	0.00	1	NCNB	Fulton		Market
PG&E	ZZZZ_WDFRDF_2_UNIT S	31404	WEST FOR	13.8	0.00	2	NCNB	Fulton		Market
PG&E	ZZZZ_GEYS17_2_BOTR CK	31421	BOTTLERK	13.8	0.00	1	NCNB	Fulton	Retired	Market
PG&E	ALLGNY_6_HYDRO1				0.03		Sierra		Not modeled Aug NQC	Market
PG&E	APLHIL_1_SLABCK				0.00	1	Sierra	South of Rio Oso, South of Palermo	Not modeled Energy Only	Market
PG&E	BANGOR_6_HYDRO				1.00		Sierra		Not modeled Aug NQC	Market
PG&E	BELDEN_7_UNIT 1	31784	BELDEN	13.8	119.00	1	Sierra	South of Palermo	Aug NQC	Market
PG&E	BIOMAS_1_UNIT 1	32156	WOODLAND	9.11	24.79	1	Sierra	Drum-Rio Oso, South of Palermo	Aug NQC	Net Seller
PG&E	BNNIEN_7_ALTAPH	32376	BONNIE N	60	0.57		Sierra	Placer, Drum-Rio Oso, South of Rio Oso, South of Palermo	Not modeled Aug NQC	Market
PG&E	BOGUE_1_UNITA1	32451	FREC	13.8	47.60	1	Sierra	Bogue, Drum-Rio Oso	Aug NQC	Market

Attachment A - List of physical resources by PTO, local area and market ID

PG&E	BOWMN_6_HYDRO	32480	BOWMAN	9.11	2.57	1	Sierra	Drum-Rio Oso, South of Palermo	Aug NQC	MUNI
PG&E	BUCKCK_2_HYDRO				0.28		Sierra	South of Palermo	Not modeled Aug NQC	Market
PG&E	BUCKCK_7_OAKFLT				1.30		Sierra	South of Palermo	Not modeled Aug NQC	Market
PG&E	BUCKCK_7_PL1X2	31820	BCKS CRK	11	30.63	1	Sierra	South of Palermo	Aug NQC	Market
PG&E	BUCKCK_7_PL1X2	31820	BCKS CRK	11	26.62	2	Sierra	South of Palermo	Aug NQC	Market
PG&E	CAMPFW_7_FARWST	32470	CMP.FARW	9.11	2.90	1	Sierra		Aug NQC	MUNI
PG&E	CHICPK_7_UNIT 1	32462	CHI.PARK	11.5	42.00	1	Sierra	Placer, Drum-Rio Oso, South of Rio Oso, South of Palermo	Aug NQC	MUNI
PG&E	COLGAT_7_UNIT 1	32450	COLGATE1	13.8	161.65	1	Sierra		Aug NQC	MUNI
PG&E	COLGAT_7_UNIT 2	32452	COLGATE2	13.8	161.68	1	Sierra		Aug NQC	MUNI
PG&E	CRESTA_7_PL1X2	31812	CRESTA	11.5	34.86	1	Sierra	South of Palermo	Aug NQC	Market
PG&E	CRESTA_7_PL1X2	31812	CRESTA	11.5	35.54	2	Sierra	South of Palermo	Aug NQC	Market
PG&E	DAVIS_1_SOLAR1				0.41		Sierra	Drum-Rio Oso, South of Palermo	Not modeled Aug NQC	Solar
PG&E	DAVIS_1_SOLAR2				0.41		Sierra	Drum-Rio Oso, South of Palermo	Not modeled Aug NQC	Solar
PG&E	DAVIS_7_MNMETH				1.52		Sierra	Drum-Rio Oso, South of Palermo	Not modeled Aug NQC	Market
PG&E	DEADCK_1_UNIT	31862	DEADWOOD	9.11	0.00	1	Sierra	Drum-Rio Oso	Aug NQC	MUNI
PG&E	DEERCR_6_UNIT 1	32474	DEER CRK	9.11	3.04	1	Sierra	Drum-Rio Oso, South of Palermo	Aug NQC	Market
PG&E	DRUM_7_PL1X2	32504	DRUM 1-2	6.6	13.00	1	Sierra	Drum-Rio Oso, South of Palermo	Aug NQC	Market
PG&E	DRUM_7_PL1X2	32504	DRUM 1-2	6.6	13.00	2	Sierra	Drum-Rio Oso, South of Palermo	Aug NQC	Market
PG&E	DRUM_7_PL3X4	32506	DRUM 3-4	6.6	13.26	1	Sierra	Drum-Rio Oso, South of Palermo	Aug NQC	Market
PG&E	DRUM_7_PL3X4	32506	DRUM 3-4	6.6	15.64	2	Sierra	Drum-Rio Oso, South of Palermo	Aug NQC	Market
PG&E	DRUM_7_UNIT 5	32454	DRUM 5	13.8	50.00	1	Sierra	Drum-Rio Oso, South of Palermo	Aug NQC	Market

Attachment A - List of physical resources by PTO, local area and market ID

PG&E	DUTCH1_7_UNIT 1	32464	DTCHFLT1	11	22.00	1	Sierra	Placer, Drum-Rio Oso, South of Rio Oso, South of Palermo	Aug NQC	Market
PG&E	DUTCH2_7_UNIT 1	32502	DTCHFLT2	6.9	26.00	1	Sierra	Drum-Rio Oso, South of Palermo	Aug NQC	MUNI
PG&E	ELDORO_7_UNIT 1	32513	ELDRADO1	21.6	11.00	1	Sierra	South of Rio Oso, South of Palermo		Market
PG&E	ELDORO_7_UNIT 2	32514	ELDRADO2	21.6	11.00	1	Sierra	South of Rio Oso, South of Palermo		Market
PG&E	FMEADO_6_HELLHL	32486	HELLHOLE	9.11	0.37	1	Sierra	South of Rio Oso, South of Palermo	Aug NQC	MUNI
PG&E	FMEADO_7_UNIT	32508	FRNCH MD	4.2	16.00	1	Sierra	South of Rio Oso, South of Palermo	Aug NQC	MUNI
PG&E	FORBST_7_UNIT 1	31814	FORBSTWN	11.5	37.50	1	Sierra	Drum-Rio Oso	Aug NQC	MUNI
PG&E	GRIDLY_6_SOLAR	38054	GRIDLEY	60	0.00	1	Sierra	Pease	Energy Only	Solar
PG&E	GRNLF1_1_UNITS	32490	GRNLEAF1	13.8	33.36	1	Sierra	Bogue, Drum-Rio Oso	Aug NQC	Market
PG&E	GRNLF1_1_UNITS	32491	GRNLEAF1	13.8	15.84	2	Sierra	Bogue, Drum-Rio Oso	Aug NQC	Market
PG&E	GRNLF2_1_UNIT	32492	GRNLEAF2	13.8	37.77	1	Sierra	Pease, Drum-Rio Oso	Aug NQC	QF/Selfgen
PG&E	HALSEY_6_UNIT	32478	HALSEY F	9.11	13.50	1	Sierra	Placer, Drum-Rio Oso, South of Rio Oso, South of Palermo	Aug NQC	Market
PG&E	HAYPRS_6_QFUNTS	32488	HAYPRES+	9.11	0.04	1	Sierra	Drum-Rio Oso, South of Palermo	Aug NQC	QF/Selfgen
PG&E	HAYPRS_6_QFUNTS	32488	HAYPRES+	9.11	0.05	2	Sierra	Drum-Rio Oso, South of Palermo	Aug NQC	QF/Selfgen
PG&E	HIGGNS_1_COMBIE				0.11		Sierra	Drum-Rio Oso, South of Rio Oso, South of Palermo	Not modeled Aug NQC	Market
PG&E	HIGGNS_7_QFUNTS				0.22		Sierra	Drum-Rio Oso, South of Rio Oso, South of Palermo	Not modeled Aug NQC	QF/Selfgen
PG&E	KANAKA_1_UNIT				0.00		Sierra	Drum-Rio Oso	Not modeled Aug NQC	MUNI
PG&E	KELYRG_6_UNIT	31834	KELLYRDG	9.11	11.00	1	Sierra	Drum-Rio Oso	Aug NQC	MUNI

Attachment A - List of physical resources by PTO, local area and market ID

PG&E	LIVEOK_6_SOLAR				0.51		Sierra	Pease	Not modeled Aug NQC	Solar
PG&E	LODIEC_2_PL1X2	38124	LODI ST1	18	103.55	1	Sierra	South of Rio Oso, South of Palermo		MUNI
PG&E	LODIEC_2_PL1X2	38123	LODI CT1	18	199.03	1	Sierra	South of Rio Oso, South of Palermo		MUNI
PG&E	MDFKRL_2_PROJCT	32456	MIDLFORK	13.8	63.94	1	Sierra	South of Rio Oso, South of Palermo	Aug NQC	MUNI
PG&E	MDFKRL_2_PROJCT	32458	RALSTON	13.8	82.13	1	Sierra	South of Rio Oso, South of Palermo	Aug NQC	MUNI
PG&E	MDFKRL_2_PROJCT	32456	MIDLFORK	13.8	63.94	2	Sierra	South of Rio Oso, South of Palermo	Aug NQC	MUNI
PG&E	NAROW1_2_UNIT	32466	NARROWS1	9.1	12.00	1	Sierra		Aug NQC	Market
PG&E	NAROW2_2_UNIT	32468	NARROWS2	9.1	28.51	1	Sierra		Aug NQC	MUNI
PG&E	NWCSTL_7_UNIT 1	32460	NEWCASTLE	13.2	0.06	1	Sierra	Placer, Drum-Rio Oso, South of Rio Oso, South of Palermo	Aug NQC	Market
PG&E	OROVIL_6_UNIT	31888	OROVILLE	9.11	7.50	1	Sierra	Drum-Rio Oso	Aug NQC	Market
PG&E	OXBOW_6_DRUM	32484	OXBOW F	9.11	3.37	1	Sierra	Drum-Rio Oso, South of Palermo	Aug NQC	MUNI
PG&E	PLACVL_1_CHILIB	32510	CHILIBAR	4.2	8.40	1	Sierra	South of Rio Oso, South of Palermo	Aug NQC	Market
PG&E	PLACVL_1_RCKCRE				2.39		Sierra	South of Rio Oso, South of Palermo	Not modeled Aug NQC	Market
PG&E	PLSNTG_7_LNCLND	32408	PLSNT GR	60	3.06		Sierra	Drum-Rio Oso, South of Rio Oso, South of Palermo	Not modeled Aug NQC	Market
PG&E	POEPH_7_UNIT 1	31790	POE 1	13.8	60.00	1	Sierra	South of Palermo	Aug NQC	Market
PG&E	POEPH_7_UNIT 2	31792	POE 2	13.8	60.00	1	Sierra	South of Palermo	Aug NQC	Market
PG&E	RCKCRK_7_UNIT 1	31786	ROCK CK1	13.8	57.00	1	Sierra	South of Palermo	Aug NQC	Market
PG&E	RCKCRK_7_UNIT 2	31788	ROCK CK2	13.8	56.90	1	Sierra	South of Palermo	Aug NQC	Market
PG&E	RIOOSO_1_QF				0.94		Sierra	Drum-Rio Oso, South of Palermo	Not modeled Aug NQC	QF/Selfgen
PG&E	ROLLIN_6_UNIT	32476	ROLLINSF	9.11	13.50	1	Sierra	Drum-Rio Oso, South of Palermo	Aug NQC	MUNI
PG&E	SLYCRK_1_UNIT 1	31832	SLY.CR.	9.11	13.00	1	Sierra	Drum-Rio Oso	Aug NQC	Market

Attachment A - List of physical resources by PTO, local area and market ID

PG&E	SPAULD_6_UNIT 3	32472	SPAULDG	9.11	3.27	3	Sierra	Drum-Rio Oso, South of Palermo	Aug NQC	Market
PG&E	SPAULD_6_UNIT12	32472	SPAULDG	9.11	7.00	1	Sierra	Drum-Rio Oso, South of Palermo	Aug NQC	Market
PG&E	SPAULD_6_UNIT12	32472	SPAULDG	9.11	4.40	2	Sierra	Drum-Rio Oso, South of Palermo	Aug NQC	Market
PG&E	SPI LI_2_UNIT 1	32498	SPILINCF	12.5	10.19	1	Sierra	Drum-Rio Oso, South of Rio Oso, South of Palermo	Aug NQC	Net Seller
PG&E	STIGCT_2_LODI	38114	Stig CC	13.8	49.50	1	Sierra	South of Rio Oso, South of Palermo		MUNI
PG&E	ULTRCK_2_UNIT	32500	ULTR RCK	9.11	22.83	1	Sierra	Drum-Rio Oso, South of Rio Oso, South of Palermo	Aug NQC	Market
PG&E	WDLEAF_7_UNIT 1	31794	WOODLEAF	13.8	60.00	1	Sierra	Drum-Rio Oso	Aug NQC	MUNI
PG&E	WHEATL_6_LNDFIL	32350	WHEATLND	60	3.55		Sierra		Not modeled Aug NQC	Market
PG&E	WISE_1_UNIT 1	32512	WISE	12	14.50	1	Sierra	Placer, Drum-Rio Oso, South of Rio Oso, South of Palermo	Aug NQC	Market
PG&E	WISE_1_UNIT 2	32512	WISE	12	3.20	1	Sierra	Placer, Drum-Rio Oso, South of Rio Oso, South of Palermo	Aug NQC	Market
PG&E	YUBACT_1_SUNSWT	32494	YUBA CTY	9.11	49.97	1	Sierra	Pease, Drum-Rio Oso	Aug NQC	Net Seller
PG&E	YUBACT_6_UNITA1	32496	YCEC	13.8	47.60	1	Sierra	Pease, Drum-Rio Oso		Market
PG&E	ZZ_NA	32162	RIV.DLTA	9.11	0.00	1	Sierra	Drum-Rio Oso, South of Palermo	No NQC - hist. data	QF/Selfgen
PG&E	ZZ_UCDAVS_1_UNIT	32166	UC DAVIS	9.11	0.00	RN	Sierra	Drum-Rio Oso, South of Palermo	No NQC - hist. data	QF/Selfgen
PG&E	ZZZ_New Unit	365510	Q653F	0.48	4.92	1	Sierra	Drum-Rio Oso, South of Palermo	No NQC - est. data	Solar
PG&E	ZZZZ_GOLDHL_1_QF				0.00		Sierra	South of Rio Oso, South of Palermo	Not modeled	QF/Selfgen
PG&E	ZZZZ_PACORO_6_UNIT	31890	PO POWER	9.11	0.00	1	Sierra	Drum-Rio Oso	Retired	QF/Selfgen

Attachment A - List of physical resources by PTO, local area and market ID

PG&E	ZZZZ_PACORO_6_UNIT	31890	PO POWER	9.11	0.00	2	Sierra	Drum-Rio Oso	Retired	QF/Selfgen
PG&E	BEARDS_7_UNIT 1	34074	BEARDSLY	6.9	8.36	1	Stockton	Tesla-Bellota, Stanislaus	Aug NQC	MUNI
PG&E	CAMCHE_1_PL1X3	33850	CAMANCHE	4.2	0.79	1	Stockton	Tesla-Bellota	Aug NQC	MUNI
PG&E	CAMCHE_1_PL1X3	33850	CAMANCHE	4.2	0.79	2	Stockton	Tesla-Bellota	Aug NQC	MUNI
PG&E	CAMCHE_1_PL1X3	33850	CAMANCHE	4.2	0.79	3	Stockton	Tesla-Bellota	Aug NQC	MUNI
PG&E	COGNAT_1_UNIT	33818	STCKNBIOMASS	13.8	44.35	1	Stockton	Weber	Aug NQC	Net Seller
PG&E	CRWCKS_1_SOLAR1	34051	Q539	34.5	0.00	1	Stockton	Tesla-Bellota	Energy Only	Solar
PG&E	DONNLS_7_UNIT	34058	DONNELLS	13.8	72.00	1	Stockton	Tesla-Bellota, Stanislaus	Aug NQC	MUNI
PG&E	FROGTN_1_UTICAA				1.40		Stockton	Tesla-Bellota, Stanislaus	Not Modeled Aug NQC	Market
PG&E	LOCKFD_1_BEARCK				0.62		Stockton	Tesla-Bellota	Not Modeled Aug NQC	Market
PG&E	LOCKFD_1_KSOLAR				0.41		Stockton	Tesla-Bellota	Not Modeled Aug NQC	Solar
PG&E	LODI25_2_UNIT 1	38120	LODI25CT	9.11	23.80	1	Stockton	Lockeford		MUNI
PG&E	MANTEC_1_ML1SR1				0.00		Stockton	Tesla-Bellota	Not modeled Energy Only	Solar
PG&E	PEORIA_1_SOLAR				0.62		Stockton	Tesla-Bellota, Stanislaus	Not modeled Aug NQC	Solar
PG&E	PHOENX_1_UNIT				0.82		Stockton	Tesla-Bellota, Stanislaus	Not modeled Aug NQC	Market
PG&E	SCHLTE_1_PL1X3	33805	GWFTRCY1	13.8	91.07	1	Stockton	Tesla-Bellota		Market
PG&E	SCHLTE_1_PL1X3	33807	GWFTRCY2	13.8	91.07	1	Stockton	Tesla-Bellota		Market
PG&E	SCHLTE_1_PL1X3	33811	GWFTRCY3	13.8	146.76	1	Stockton	Tesla-Bellota		Market
PG&E	SNDBAR_7_UNIT 1	34060	SANDBAR	13.8	12.93	1	Stockton	Tesla-Bellota, Stanislaus	Aug NQC	MUNI
PG&E	SPIFBD_1_PL1X2	34055	SPISONORA	13.8	7.05	1	Stockton	Tesla-Bellota, Stanislaus	Aug NQC	Market
PG&E	SPRGAP_1_UNIT 1	34078	SPRNG GP	6	0.00	1	Stockton	Tesla-Bellota, Stanislaus	Aug NQC	Market
PG&E	STANIS_7_UNIT 1	34062	STANISLS	13.8	91.00	1	Stockton	Tesla-Bellota, Stanislaus	Aug NQC	Market
PG&E	STNRES_1_UNIT	34056	STNSLSRP	13.8	19.04	1	Stockton	Tesla-Bellota	Aug NQC	Net Seller
PG&E	TULLCK_7_UNITS	34076	TULLOCH	6.9	5.95	1	Stockton	Tesla-Bellota	Aug NQC	MUNI

Attachment A - List of physical resources by PTO, local area and market ID

PG&E	TULLCK_7_UNITS	34076	TULLOCH	6.9	6.70	2	Stockton	Tesla-Bellota	Aug NQC	MUNI
PG&E	TULLCK_7_UNITS	34076	TULLOCH	6.9	4.40	3	Stockton	Tesla-Bellota	Aug NQC	MUNI
PG&E	ULTPCH_1_UNIT 1	34050	CH.STN.	13.8	16.19	1	Stockton	Tesla-Bellota, Stanislaus	Aug NQC	QF/Selfgen
PG&E	VLYHOM_7_SSID				0.57		Stockton	Tesla-Bellota, Stanislaus	Not modeled Aug NQC	MUNI
PG&E	WEBER_6_FORWRD				4.20		Stockton	Weber	Not modeled Aug NQC	Market
PG&E	ZZ_NA	33687	STKTN WW	60	1.50	1	Stockton	Weber	No NQC - hist. data	QF/Selfgen
PG&E	ZZ_NA	33821	PAC_ETH	12.5	0.00	RN	Stockton	Weber	No NQC - hist. data	QF/Selfgen
PG&E	ZZZZ_FROGTN_7_UTICA				0.00		Stockton	Tesla-Bellota, Stanislaus	Not modeled Energy Only	Market
PG&E	ZZZZ_STOKCG_1_UNIT 1	33814	INGREDION	12.5	0.00	RN	Stockton	Tesla-Bellota	Retired	QF/Selfgen
PG&E	ZZZZZ_NA	33830	GEN.MILL	9.11	0.00	1	Stockton	Lockeford	Retired	QF/Selfgen
SCE	ACACIA_6_SOLAR	29878	ACACIA_G	0.48	8.20	EQ	BC/Ventura		Energy Only	Solar
SCE	ALAMO_6_UNIT	25653	ALAMO SC	13.8	15.07	1	BC/Ventura		Aug NQC	MUNI
SCE	BGSKYN_2_AS2SR1	29773	ANTLOP2_G1	0.42	43.05	EQ	BC/Ventura		Aug NQC	Solar
SCE	BIGCRK_2_EXESWD	24323	PORTAL	4.8	9.45	1	BC/Ventura	Rector, Vestal	Aug NQC	Market
SCE	BIGCRK_2_EXESWD	24306	B CRK1-1	7.2	19.58	1	BC/Ventura	Rector, Vestal	Aug NQC	Market
SCE	BIGCRK_2_EXESWD	24311	B CRK3-1	13.8	34.44	1	BC/Ventura	Rector, Vestal	Aug NQC	Market
SCE	BIGCRK_2_EXESWD	24308	B CRK2-1	13.8	49.99	1	BC/Ventura	Rector, Vestal	Aug NQC	Market
SCE	BIGCRK_2_EXESWD	24317	MAMOTH1G	13.8	92.02	1	BC/Ventura	Rector, Vestal	Aug NQC	Market
SCE	BIGCRK_2_EXESWD	24306	B CRK1-1	7.2	21.26	2	BC/Ventura	Rector, Vestal	Aug NQC	Market
SCE	BIGCRK_2_EXESWD	24311	B CRK3-1	13.8	33.46	2	BC/Ventura	Rector, Vestal	Aug NQC	Market
SCE	BIGCRK_2_EXESWD	24308	B CRK2-1	13.8	51.18	2	BC/Ventura	Rector, Vestal	Aug NQC	Market
SCE	BIGCRK_2_EXESWD	24318	MAMOTH2G	13.8	92.02	2	BC/Ventura	Rector, Vestal	Aug NQC	Market
SCE	BIGCRK_2_EXESWD	24309	B CRK2-2	7.2	18.40	3	BC/Ventura	Rector, Vestal	Aug NQC	Market
SCE	BIGCRK_2_EXESWD	24307	B CRK1-2	13.8	21.26	3	BC/Ventura	Rector, Vestal	Aug NQC	Market
SCE	BIGCRK_2_EXESWD	24312	B CRK3-2	13.8	34.44	3	BC/Ventura	Rector, Vestal	Aug NQC	Market
SCE	BIGCRK_2_EXESWD	24309	B CRK2-2	7.2	19.39	4	BC/Ventura	Rector, Vestal	Aug NQC	Market
SCE	BIGCRK_2_EXESWD	24307	B CRK1-2	13.8	30.71	4	BC/Ventura	Rector, Vestal	Aug NQC	Market
SCE	BIGCRK_2_EXESWD	24312	B CRK3-2	13.8	35.43	4	BC/Ventura	Rector, Vestal	Aug NQC	Market
SCE	BIGCRK_2_EXESWD	24310	B CRK2-3	7.2	16.73	5	BC/Ventura	Rector, Vestal	Aug NQC	Market

Attachment A - List of physical resources by PTO, local area and market ID

SCE	BIGCRK_2_EXESWD	24313	B CRK3-3	13.8	35.92	5	BC/Ventura	Rector, Vestal	Aug NQC	Market
SCE	BIGCRK_2_EXESWD	24310	B CRK2-3	7.2	18.21	6	BC/Ventura	Rector, Vestal	Aug NQC	Market
SCE	BIGCRK_2_EXESWD	24314	B CRK 4	11.5	49.60	41	BC/Ventura	Rector, Vestal	Aug NQC	Market
SCE	BIGCRK_2_EXESWD	24314	B CRK 4	11.5	49.80	42	BC/Ventura	Rector, Vestal	Aug NQC	Market
SCE	BIGCRK_2_EXESWD	24315	B CRK 8	13.8	24.01	81	BC/Ventura	Rector, Vestal	Aug NQC	Market
SCE	BIGCRK_2_EXESWD	24315	B CRK 8	13.8	43.30	82	BC/Ventura	Rector, Vestal	Aug NQC	Market
SCE	BIGCRK_7_DAM7				0.00		BC/Ventura	Rector, Vestal	Not modeled Energy Only	Market
SCE	BIGCRK_7_MAMRES				0.00		BC/Ventura	Rector, Vestal	Not modeled Energy Only	Market
SCE	BIGSKY_2_BSKSR6	29742	BSKY G BC	0.42	8.20	1	BC/Ventura		Aug NQC	Solar
SCE	BIGSKY_2_BSKSR7	29703	BSKY G WABS	0.42	8.20	1	BC/Ventura		Aug NQC	Solar
SCE	BIGSKY_2_BSKSR8	29724	BSKY G ABSR	0.38	8.20	1	BC/Ventura		Aug NQC	Solar
SCE	BIGSKY_2_SOLAR1	29727	BSKY G SMR	0.42	8.20	1	BC/Ventura		Aug NQC	Solar
SCE	BIGSKY_2_SOLAR2	29701	BSKY_G_ESC	0.42	34.41	1	BC/Ventura		Aug NQC	Solar
SCE	BIGSKY_2_SOLAR3	29745	BSKY_G_BD	0.42	8.20	1	BC/Ventura		Aug NQC	Solar
SCE	BIGSKY_2_SOLAR4	29736	BSKY_G_BA	0.42	20.00	1	BC/Ventura		Aug NQC	Solar
SCE	BIGSKY_2_SOLAR5	29739	BSKY_G_BB	0.42	2.05	1	BC/Ventura		Aug NQC	Solar
SCE	BIGSKY_2_SOLAR6	29730	BSKY_G_SOL V	0.42	34.85	1	BC/Ventura		Aug NQC	Solar
SCE	BIGSKY_2_SOLAR7	29733	BSKY_G_ADS R	0.42	20.50	1	BC/Ventura		Aug NQC	Solar
SCE	CEDUCR_2_SOLAR1	25049	DUCOR1	0.38 5	0.00	EQ	BC/Ventura	Vestal	Energy Only	Solar
SCE	CEDUCR_2_SOLAR2	25052	DUCOR2	0.38 5	0.00	EQ	BC/Ventura	Vestal	Energy Only	Solar
SCE	CEDUCR_2_SOLAR3	25055	DUCOR3	0.38 5	0.00	EQ	BC/Ventura	Vestal	Energy Only	Solar
SCE	CEDUCR_2_SOLAR4	25058	DUCOR4	0.38 5	0.00	EQ	BC/Ventura	Vestal	Energy Only	Solar
SCE	DELSUR_6_BSOLAR				1.23		BC/Ventura		Not modeled Aug NQC	Solar
SCE	DELSUR_6_CREST	24411	DELSUR_DIS T	66	0.00	A2	BC/Ventura		Energy Only	Market
SCE	DELSUR_6_DRYFRB	24411	DELSUR_DIS T	66	2.05	A2	BC/Ventura		Aug NQC	Market
SCE	DELSUR_6_SOLAR1	24411	DELSUR_DIS T	66	2.67	AS	BC/Ventura		Aug NQC	Solar

Attachment A - List of physical resources by PTO, local area and market ID

SCE	EASTWD_7_UNIT	24319	EASTWOOD	13.8	199.00	1	BC/Ventura	Rector, Vestal		Market
SCE	EDMONS_2_NSPIN	25605	EDMON1AP	14.4	16.86	1	BC/Ventura		Pumps	MUNI
SCE	EDMONS_2_NSPIN	25606	EDMON2AP	14.4	16.86	2	BC/Ventura		Pumps	MUNI
SCE	EDMONS_2_NSPIN	25607	EDMON3AP	14.4	16.86	3	BC/Ventura		Pumps	MUNI
SCE	EDMONS_2_NSPIN	25607	EDMON3AP	14.4	16.86	4	BC/Ventura		Pumps	MUNI
SCE	EDMONS_2_NSPIN	25608	EDMON4AP	14.4	16.86	5	BC/Ventura		Pumps	MUNI
SCE	EDMONS_2_NSPIN	25608	EDMON4AP	14.4	16.86	6	BC/Ventura		Pumps	MUNI
SCE	EDMONS_2_NSPIN	25609	EDMON5AP	14.4	16.86	7	BC/Ventura		Pumps	MUNI
SCE	EDMONS_2_NSPIN	25609	EDMON5AP	14.4	16.86	8	BC/Ventura		Pumps	MUNI
SCE	EDMONS_2_NSPIN	25610	EDMON6AP	14.4	16.86	9	BC/Ventura		Pumps	MUNI
SCE	EDMONS_2_NSPIN	25610	EDMON6AP	14.4	16.86	10	BC/Ventura		Pumps	MUNI
SCE	EDMONS_2_NSPIN	25611	EDMON7AP	14.4	16.85	11	BC/Ventura		Pumps	MUNI
SCE	EDMONS_2_NSPIN	25611	EDMON7AP	14.4	16.85	12	BC/Ventura		Pumps	MUNI
SCE	EDMONS_2_NSPIN	25612	EDMON8AP	14.4	16.85	13	BC/Ventura		Pumps	MUNI
SCE	EDMONS_2_NSPIN	25612	EDMON8AP	14.4	16.85	14	BC/Ventura		Pumps	MUNI
SCE	GLDFGR_6_SOLAR1	25079	PRIDE B G	0.64	8.20	1	BC/Ventura		Aug NQC	Solar
SCE	GLDFGR_6_SOLAR2	25169	PRIDE C G	0.64	4.67	1	BC/Ventura		Aug NQC	Solar
SCE	GLOW_6_SOLAR	29896	APPINV	0.42	0.00	EQ	BC/Ventura		Energy Only	Solar
SCE	GOLETA_2_QF	25335	GOLETA_DIST	66	0.05	S1	BC/Ventura	S.Clara, Moorpark, Goleta	Aug NQC	QF/Selfgen
SCE	GOLETA_6_ELLWOD	29004	ELLWOOD	13.8	54.00	1	BC/Ventura	S.Clara, Moorpark, Goleta	Retirement requested effective date January 1, 2019	Market
SCE	GOLETA_6_EXGEN	24362	EXGEN2	13.8	2.02	G1	BC/Ventura	S.Clara, Moorpark, Goleta	Aug NQC - Currently out of service	QF/Selfgen
SCE	GOLETA_6_EXGEN	24326	EXGEN1	13.8	1.39	S1	BC/Ventura	S.Clara, Moorpark, Goleta	Aug NQC - Currently out of service	QF/Selfgen
SCE	GOLETA_6_GAVOTA	25335	GOLETA_DIST	66	0.01	S1	BC/Ventura	S.Clara, Moorpark, Goleta	Aug NQC	Market
SCE	GOLETA_6_TAJIGS	25335	GOLETA_DIST	66	2.84	S1	BC/Ventura	S.Clara, Moorpark, Goleta	Aug NQC	Market
SCE	LEBECS_2_UNITS	29051	PSTRIAG1	18	165.58	G1	BC/Ventura		Aug NQC	Market

Attachment A - List of physical resources by PTO, local area and market ID

SCE	LEBECS_2_UNITS	29052	PSTRIAG2	18	165.58	G2	BC/Ventura		Aug NQC	Market
SCE	LEBECS_2_UNITS	29054	PSTRIAG3	18	165.58	G3	BC/Ventura		Aug NQC	Market
SCE	LEBECS_2_UNITS	29053	PSTRIAS1	18	170.45	S1	BC/Ventura		Aug NQC	Market
SCE	LEBECS_2_UNITS	29055	PSTRIAS2	18	82.79	S2	BC/Ventura		Aug NQC	Market
SCE	LITLRK_6_GBCSR1	24419	LTLRCK_DIST	66	1.23	AS	BC/Ventura		Aug NQC	Solar
SCE	LITLRK_6_SEPV01	24419	LTLRCK_DIST	66	0.00	AS	BC/Ventura		Energy Only	Market
SCE	LITLRK_6_SOLAR1	24419	LTLRCK_DIST	66	2.05	AS	BC/Ventura		Aug NQC	Solar
SCE	LITLRK_6_SOLAR2	24419	LTLRCK_DIST	66	0.82	AS	BC/Ventura		Aug NQC	Solar
SCE	LITLRK_6_SOLAR3	24419	LTLRCK_DIST	66	0.82	AS	BC/Ventura		Aug NQC	Solar
SCE	LITLRK_6_SOLAR4	24419	LTLRCK_DIST	66	1.23	AS	BC/Ventura		Aug NQC	Solar
SCE	LNCSTR_6_CREST				0.00		BC/Ventura		Not modeled Energy Only	Market
SCE	MNDALY_6_MCGRTH	29306	MCGPKGEN	13.8	47.20	1	BC/Ventura	S.Clara, Moorpark		Market
SCE	MOORPK_2_CALABS	25081	WDT251	13.8	5.03	EQ	BC/Ventura	Moorpark	Aug NQC	Market
SCE	MOORPK_6_QF				0.80		BC/Ventura	Moorpark	Not modeled Aug NQC	Market
SCE	NEENCH_6_SOLAR	29900	ALPINE_G	0.48	27.06	EQ	BC/Ventura		Aug NQC	Solar
SCE	OASIS_6_CREST	24421	OASIS_DIST	66	0.00	AS	BC/Ventura		Energy Only	Market
SCE	OASIS_6_GBDSR4				1.23		BC/Ventura		Not modeled Aug NQC	Solar
SCE	OASIS_6_SOLAR1	25095	SOLARISG2	0.2	0.00	EQ	BC/Ventura		Not modeled Energy Only	Solar
SCE	OASIS_6_SOLAR2	25075	SOLARISG	0.2	8.20	EQ	BC/Ventura		Aug NQC	Solar
SCE	OASIS_6_SOLAR3				0.00		BC/Ventura		Not modeled Energy Only	Solar
SCE	OMAR_2_UNIT 1	24102	OMAR 1G	13.8	74.40	1	BC/Ventura			Net Seller
SCE	OMAR_2_UNIT 2	24103	OMAR 2G	13.8	75.80	2	BC/Ventura			Net Seller
SCE	OMAR_2_UNIT 3	24104	OMAR 3G	13.8	78.60	3	BC/Ventura			Net Seller
SCE	OMAR_2_UNIT 4	24105	OMAR 4G	13.8	81.44	4	BC/Ventura			Net Seller
SCE	ORMOND_7_UNIT 1	24107	ORMOND1G	26	741.27	1	BC/Ventura	Moorpark	Retirement requested effective date October 1, 2018	Market

Attachment A - List of physical resources by PTO, local area and market ID

SCE	ORMOND_7_UNIT 2	24108	ORMOND2G	26	775.00	2	BC/Ventura	Moorpark	Retirement requested effective date October 1, 2018	Market
SCE	OSO_6_NSPIN	25614	OSO A P	13.2	2.25	1	BC/Ventura		Pumps	MUNI
SCE	OSO_6_NSPIN	25614	OSO A P	13.2	2.25	2	BC/Ventura		Pumps	MUNI
SCE	OSO_6_NSPIN	25614	OSO A P	13.2	2.25	3	BC/Ventura		Pumps	MUNI
SCE	OSO_6_NSPIN	25614	OSO A P	13.2	2.25	4	BC/Ventura		Pumps	MUNI
SCE	OSO_6_NSPIN	25615	OSO B P	13.2	2.25	5	BC/Ventura		Pumps	MUNI
SCE	OSO_6_NSPIN	25615	OSO B P	13.2	2.25	6	BC/Ventura		Pumps	MUNI
SCE	OSO_6_NSPIN	25615	OSO B P	13.2	2.25	7	BC/Ventura		Pumps	MUNI
SCE	OSO_6_NSPIN	25615	OSO B P	13.2	2.25	8	BC/Ventura		Pumps	MUNI
SCE	PANDOL_6_UNIT	24113	PANDOL	13.8	23.32	1	BC/Ventura	Vestal	Aug NQC	Market
SCE	PANDOL_6_UNIT	24113	PANDOL	13.8	23.32	2	BC/Ventura	Vestal	Aug NQC	Market
SCE	PLAINV_6_BSOLAR	29917	SSOLAR)GR WKS	0.8	0.00	1	BC/Ventura		Energy Only	Solar
SCE	PLAINV_6_DSOLAR	29914	WADR_PV	0.42	4.10	1	BC/Ventura		Aug NQC	Solar
SCE	PLAINV_6_NLRSR1	29921	NLR_INVTR	0.42	0.00	1	BC/Ventura		Aug NQC	Solar
SCE	PLAINV_6_SOLAR3	25089	CNTRL ANT G	0.42	0.00	1	BC/Ventura		Energy Only	Solar
SCE	PLAINV_6_SOLARC	25086	SIRA SOLAR G	0.8	0.00	1	BC/Ventura		Energy Only	Solar
SCE	PMDLET_6_SOLAR1				4.10		BC/Ventura		Not modeled Aug NQC	Solar
SCE	RECTOR_2_CREST	25333	RECTOR_DIS T	66	0.00	S1	BC/Ventura	Rector, Vestal	Aug NQC	Market
SCE	RECTOR_2_KAWEAH	24370	KAWGEN	13.8	1.77	1	BC/Ventura	Rector, Vestal	Aug NQC	Market
SCE	RECTOR_2_KAWH 1	24370	KAWGEN	13.8	0.65	1	BC/Ventura	Rector, Vestal	Aug NQC	Market
SCE	RECTOR_2_QF	25333	RECTOR_DIS T	66	0.07	S1	BC/Ventura	Rector, Vestal	Aug NQC	QF/Selfgen
SCE	RECTOR_7_TULARE	25333	RECTOR_DIS T	66	0.00	S1	BC/Ventura	Rector, Vestal	Aug NQC	Market
SCE	REDMAN_2_SOLAR	24425	REDMAN_DIS T	66	1.54	AS	BC/Ventura		Aug NQC	Solar
SCE	ROSMND_6_SOLAR	24434	ROSAMOND_DIS	66	1.23	AS	BC/Ventura		Aug NQC	Solar
SCE	RSMSLR_6_SOLAR1	29984	DAWNGEN	0.8	8.20	EQ	BC/Ventura		Aug NQC	Solar
SCE	RSMSLR_6_SOLAR2	29888	TWILGHTG	0.8	8.20	EQ	BC/Ventura		Aug NQC	Solar

Attachment A - List of physical resources by PTO, local area and market ID

SCE	SAUGUS_2_TOLAND	24135	SAUGUS	66	0.00		BC/Ventura		Not modeled Energy Only	Market
SCE	SAUGUS_6_MWDFTH	25336	SAUGUS_MW D	66	8.76	S1	BC/Ventura		Aug NQC	MUNI
SCE	SAUGUS_6_PTCHGN	24118	PITCHGEN	13.8	20.64	D1	BC/Ventura		Aug NQC	MUNI
SCE	SAUGUS_6_QF	24135	SAUGUS	66	0.62		BC/Ventura		Not modeled Aug NQC	QF/Selfgen
SCE	SAUGUS_7_CHIQCN	24135	SAUGUS	66	5.71		BC/Ventura		Not modeled Aug NQC	Market
SCE	SAUGUS_7_LOPEZ	24135	SAUGUS	66	5.34		BC/Ventura		Not modeled Aug NQC	QF/Selfgen
SCE	SHUTLE_6_CREST	24426	SHUTTLE_DIS T	66	0.00	AS	BC/Ventura		Energy Only	Market
SCE	SNCLRA_2_HOWLNG	25080	SANTACL_R_D IS	13.8	10.07	EQ	BC/Ventura	S.Clara, Moorpark	Aug NQC	Market
SCE	SNCLRA_2_SPRHYD	25080	SANTACL_R_D IS	13.8	0.37	EQ	BC/Ventura	S.Clara, Moorpark	Aug NQC	Market
SCE	SNCLRA_2_UNIT	29952	CAMGEN	13.8	24.49	D1	BC/Ventura	S.Clara, Moorpark	Aug NQC	Market
SCE	SNCLRA_2_UNIT1	24159	WILLAMET	3.8	17.54	D1	BC/Ventura	S.Clara, Moorpark	Aug NQC	Market
SCE	SNCLRA_6_OXGEN	24110	OXGEN	13.8	35.10	D1	BC/Ventura	S.Clara, Moorpark	Aug NQC	QF/Selfgen
SCE	SNCLRA_6_PROCGN	24119	PROCGEN	13.8	45.79	D1	BC/Ventura	S.Clara, Moorpark	Aug NQC	Market
SCE	SNCLRA_6_QF	25080	SANTACL_R_D IS	13.8	0.27	EQ	BC/Ventura	S.Clara, Moorpark	Aug NQC	QF/Selfgen
SCE	SPRGVL_2_CREST	25334	SPRNGVL_DI ST	66	0.00	S1	BC/Ventura	Rector, Vestal	Energy Only	Market
SCE	SPRGVL_2_QF	25334	SPRNGVL_DI ST	66	0.12	S1	BC/Ventura	Rector, Vestal	Aug NQC	QF/Selfgen
SCE	SPRGVL_2_TULE	25334	SPRNGVL_DI ST	66	0.00	S1	BC/Ventura	Rector, Vestal	Aug NQC	Market
SCE	SPRGVL_2_TULESC	25334	SPRNGVL_DI ST	66	0.47	S1	BC/Ventura	Rector, Vestal	Aug NQC	Market
SCE	SUNSHN_2_LNDFL	29954	WDT273	13.6 6	3.34	1	BC/Ventura		Aug NQC	Market
SCE	SUNSHN_2_LNDFL	29954	WDT273	13.6 6	3.34	2	BC/Ventura		Aug NQC	Market
SCE	SUNSHN_2_LNDFL	29954	WDT273	13.6 6	3.34	3	BC/Ventura		Aug NQC	Market
SCE	SUNSHN_2_LNDFL	29954	WDT273	13.6 6	3.34	4	BC/Ventura		Aug NQC	Market

Attachment A - List of physical resources by PTO, local area and market ID

SCE	SUNSHN_2_LNDFL	29954	WDT273	13.6 6	3.34	5	BC/Ventura		Aug NQC	Market
SCE	SYCAMR_2_UNIT 1	24143	SYCCYN1G	13.8	85.00	1	BC/Ventura		Aug NQC	Net Seller
SCE	SYCAMR_2_UNIT 2	24144	SYCCYN2G	13.8	85.00	2	BC/Ventura		Aug NQC	Net Seller
SCE	SYCAMR_2_UNIT 3	24145	SYCCYN3G	13.8	85.00	3	BC/Ventura		Aug NQC	Net Seller
SCE	SYCAMR_2_UNIT 4	24146	SYCCYN4G	13.8	85.00	4	BC/Ventura		Aug NQC	Net Seller
SCE	TENGEN_2_PL1X2	24148	TENNGEN1	13.8	18.81	D1	BC/Ventura		Aug NQC	Net Seller
SCE	TENGEN_2_PL1X2	24149	TENNGEN2	13.8	18.81	D2	BC/Ventura		Aug NQC	Net Seller
SCE	VESTAL_2_KERN	24372	KR 3-1	11	5.65	1	BC/Ventura	Vestal	Aug NQC	QF/Selfgen
SCE	VESTAL_2_KERN	24373	KR 3-2	11	5.32	2	BC/Ventura	Vestal	Aug NQC	QF/Selfgen
SCE	VESTAL_2_RTS042				0.00		BC/Ventura	Vestal	Not modeled Energy Only	Market
SCE	VESTAL_2_SOLAR1	25064	TULRESLR_1	0.39	8.20	1	BC/Ventura	Vestal	Aug NQC	Solar
SCE	VESTAL_2_SOLAR2	25065	TULRESLR_2	0.39	5.74	1	BC/Ventura	Vestal	Aug NQC	Solar
SCE	VESTAL_2_UNIT1				4.77		BC/Ventura	Vestal	Not modeled Aug NQC	Market
SCE	VESTAL_2_WELLHD	24116	WELLGEN	13.8	49.00	1	BC/Ventura	Vestal		Market
SCE	VESTAL_6_QF	29008	LAKEGEN	13.8	4.18	1	BC/Ventura	Vestal	Aug NQC	QF/Selfgen
SCE	WARNE_2_UNIT	25651	WARNE1	13.8	21.80	1	BC/Ventura		Aug NQC	MUNI
SCE	WARNE_2_UNIT	25652	WARNE2	13.8	21.80	2	BC/Ventura		Aug NQC	MUNI
SCE	ZZ_NA	24340	CHARMIN	13.8	2.80	1	BC/Ventura	S.Clara, Moorpark	No NQC - hist. data	QF/Selfgen
SCE	ZZZZ_APPGEN_6_UNIT 1	24009	APPGEN1G	13.8	0.00	1	BC/Ventura		Retired	Market
SCE	ZZZZ_APPGEN_6_UNIT 1	24010	APPGEN2G	13.8	0.00	2	BC/Ventura		Retired	Market
SCE	ZZZZ_APPGEN_6_UNIT 1	24361	APPGEN3G	13.8	0.00	3	BC/Ventura		Retired	Market
SCE	ZZZZ_MNDALY_7_UNIT 1	24089	MANDLY1G	13.8	0.00	1	BC/Ventura	S.Clara, Moorpark	Retired	Market
SCE	ZZZZ_MNDALY_7_UNIT 2	24090	MANDLY2G	13.8	0.00	2	BC/Ventura	S.Clara, Moorpark	Retired	Market
SCE	ZZZZ_MNDALY_7_UNIT 3	24222	MANDLY3G	16	0.00	3	BC/Ventura	S.Clara, Moorpark	Retired	Market
SCE	ZZZZ_MOORPK_7_UNIT A1	24098	MOORPARK	66	0.00		BC/Ventura	Moorpark	Not modeled Aug NQC	Market

Attachment A - List of physical resources by PTO, local area and market ID

SCE	ZZZZ_SNCLRA_6_WILLM T	24159	WILLAMET	13.8	0.00	D1	BC/Ventura	S.Clara, Moorpark	Replaced by SNCLRA_2_ UNIT1	QF/Selfgen
SCE	ZZZZ_VESTAL_6_ULTRG N	24150	ULTRAGEN	13.8	0.00	1	BC/Ventura	Vestal	Retired	QF/Selfgen
SCE	ALAMIT_7_UNIT 1	24001	ALAMT1 G	18	0.00	1	LA Basin	Western	Retired by 12/31/2019	Market
SCE	ALAMIT_7_UNIT 2	24002	ALAMT2 G	18	0.00	2	LA Basin	Western	Retired by 12/31/2019	Market
SCE	ALAMIT_7_UNIT 3	24003	ALAMT3 G	18	332.18	3	LA Basin	Western	Retired by 2021	Market
SCE	ALAMIT_7_UNIT 4	24004	ALAMT4 G	18	335.67	4	LA Basin	Western	Retired by 2021	Market
SCE	ALAMIT_7_UNIT 5	24005	ALAMT5 G	20	497.97	5	LA Basin	Western	Retired by 2021	Market
SCE	ALAMIT_7_UNIT 6	24161	ALAMT6 G	20	0.00	6	LA Basin	Western	Retired by 12/31/2019	Market
SCE	ALTWD_1_QF	25635	ALTWIND	115	3.82	Q1	LA Basin	Eastern, Valley- Devers	Aug NQC	QF/Selfgen
SCE	ALTWD_1_QF	25635	ALTWIND	115	3.82	Q2	LA Basin	Eastern, Valley- Devers	Aug NQC	QF/Selfgen
SCE	ANAHM_2_CANYN1	25211	CanyonGT 1	13.8	49.40	1	LA Basin	Western		MUNI
SCE	ANAHM_2_CANYN2	25212	CanyonGT 2	13.8	48.00	2	LA Basin	Western		MUNI
SCE	ANAHM_2_CANYN3	25213	CanyonGT 3	13.8	48.00	3	LA Basin	Western		MUNI
SCE	ANAHM_2_CANYN4	25214	CanyonGT 4	13.8	49.40	4	LA Basin	Western		MUNI
SCE	ANAHM_7_CT	25208	DowlingCTG	13.8	40.64	1	LA Basin	Western	Aug NQC	MUNI
SCE	ARCOGN_2_UNITS	24011	ARCO 1G	13.8	52.07	1	LA Basin	Western	Aug NQC	Net Seller
SCE	ARCOGN_2_UNITS	24012	ARCO 2G	13.8	52.07	2	LA Basin	Western	Aug NQC	Net Seller
SCE	ARCOGN_2_UNITS	24013	ARCO 3G	13.8	52.07	3	LA Basin	Western	Aug NQC	Net Seller
SCE	ARCOGN_2_UNITS	24014	ARCO 4G	13.8	52.07	4	LA Basin	Western	Aug NQC	Net Seller
SCE	ARCOGN_2_UNITS	24163	ARCO 5G	13.8	26.03	5	LA Basin	Western	Aug NQC	Net Seller
SCE	ARCOGN_2_UNITS	24164	ARCO 6G	13.8	26.03	6	LA Basin	Western	Aug NQC	Net Seller
SCE	BARRE_2_QF	24016	BARRE	230	0.00		LA Basin	Western	Not modeled	QF/Selfgen
SCE	BARRE_6_PEAKER	29309	BARPKGEN	13.8	47.00	1	LA Basin	Western		Market
SCE	BLAST_1_WIND	24839	BLAST	115	12.99	1	LA Basin	Eastern, Valley- Devers	Aug NQC	Wind

Attachment A - List of physical resources by PTO, local area and market ID

SCE	BUCKWD_1_NPALM1	25634	BUCKWIND	115	0.98		LA Basin	Eastern, Valley-Devers	Not modeled Aug NQC	Wind
SCE	BUCKWD_1_QF	25634	BUCKWIND	115	4.37	QF	LA Basin	Eastern, Valley-Devers	Aug NQC	QF/Selfgen
SCE	BUCKWD_7_WINTCV	25634	BUCKWIND	115	0.35	W5	LA Basin	Eastern, Valley-Devers	Aug NQC	Wind
SCE	CABZON_1_WINDA1	29290	CABAZON	33	10.87	1	LA Basin	Eastern, Valley-Devers	Aug NQC	Wind
SCE	CAPWD_1_QF	25633	CAPWIND	115	5.18	QF	LA Basin	Eastern, Valley-Devers	Aug NQC	QF/Selfgen
SCE	CENTER_2_RHONDO	24203	CENTER S	66	1.91		LA Basin	Western	Not modeled	QF/Selfgen
SCE	CENTER_2_SOLAR1				0.00		LA Basin	Western	Not modeled Energy Only	Solar
SCE	CENTER_2_TECNG1				0.00		LA Basin	Western	Not modeled Energy Only	Market
SCE	CENTER_6_PEAKER	29308	CTRPKGEN	13.8	47.00	1	LA Basin	Western		Market
SCE	CENTRY_6_PL1X4	25302	CLTNCTRY	13.8	36.00	1	LA Basin	Eastern	Aug NQC	MUNI
SCE	CHEVMN_2_UNITS	24022	CHEVGEN1	13.8	4.61	1	LA Basin	Western, El Nido	Aug NQC	Net Seller
SCE	CHEVMN_2_UNITS	24023	CHEVGEN2	13.8	4.61	2	LA Basin	Western, El Nido	Aug NQC	Net Seller
SCE	CHINO_2_APEBT1	25180	WDT1250BES S_	0.48	20.00	1	LA Basin	Eastern	Aug NQC	Battery
SCE	CHINO_2_JURUPA				0.00		LA Basin	Eastern	Not modeled Energy Only	Market
SCE	CHINO_2_QF				0.58		LA Basin	Eastern	Not modeled Aug NQC	QF/Selfgen
SCE	CHINO_2_SASOLR				0.00		LA Basin	Eastern	Not modeled Energy Only	Solar
SCE	CHINO_2_SOLAR				0.41		LA Basin	Eastern	Not modeled	Solar
SCE	CHINO_2_SOLAR2				0.00		LA Basin	Eastern	Not modeled Energy Only	Solar
SCE	CHINO_6_CIMGEN	24026	CIMGEN	13.8	25.51	D1	LA Basin	Eastern	Aug NQC	QF/Selfgen
SCE	CHINO_6_SMPPAP	24140	SIMPSON	13.8	22.78	D1	LA Basin	Eastern	Aug NQC	QF/Selfgen
SCE	CHINO_7_MILIKN	24024	CHINO	66	1.19		LA Basin	Eastern	Not modeled Aug NQC	Market
SCE	COLTON_6_AGUAM1	25303	CLTNAGUA	13.8	43.00	1	LA Basin	Eastern	Aug NQC	MUNI
SCE	CORONS_2_SOLAR				0.00		LA Basin	Eastern	Not modeled Energy Only	Solar
SCE	CORONS_6_CLRWTR	29338	CLRWTRCT	13.8	20.72	G1	LA Basin	Eastern		MUNI

Attachment A - List of physical resources by PTO, local area and market ID

SCE	CORONS_6_CLRWTR	29340	CLRWTRST	13.8	7.28	S1	LA Basin	Eastern		MUNI
SCE	DELAMO_2_SOLAR1				0.62		LA Basin	Western	Not modeled Aug NQC	Solar
SCE	DELAMO_2_SOLAR2				0.72		LA Basin	Western	Not modeled Aug NQC	Solar
SCE	DELAMO_2_SOLAR3				0.51		LA Basin	Western	Not modeled Aug NQC	Solar
SCE	DELAMO_2_SOLAR4				0.53		LA Basin	Western	Not modeled Aug NQC	Solar
SCE	DELAMO_2_SOLAR5				0.41		LA Basin	Western	Not modeled Aug NQC	Solar
SCE	DELAMO_2_SOLAR6				0.82		LA Basin	Western	Not modeled Aug NQC	Solar
SCE	DELAMO_2_SOLRC1				0.00		LA Basin	Western	Not modeled Energy Only	Solar
SCE	DELAMO_2_SOLRD				0.00		LA Basin	Western	Not modeled Energy Only	Solar
SCE	DEVERS_1_QF	25632	TERAWND	115	8.63	QF	LA Basin	Eastern, Valley-Devers	Aug NQC	QF/Selfgen
SCE	DEVERS_1_QF	25639	SEAWIND	115	10.35	QF	LA Basin	Eastern, Valley-Devers	Aug NQC	QF/Selfgen
SCE	DEVERS_1_SEPV05				0.00		LA Basin	Eastern, Valley-Devers	Not modeled Energy Only	Market
SCE	DEVERS_1_SOLAR				0.00		LA Basin	Eastern, Valley-Devers	Not modeled Energy Only	Solar
SCE	DEVERS_1_SOLAR1				0.00		LA Basin	Eastern, Valley-Devers	Not modeled Energy Only	Solar
SCE	DEVERS_1_SOLAR2				0.00		LA Basin	Eastern, Valley-Devers	Not modeled Energy Only	Solar
SCE	DEVERS_2_CS2SR4				0.00		LA Basin	Eastern, Valley-Devers	Not modeled Energy Only	Solar
SCE	DEVERS_2_DHSPG2				0.00		LA Basin	Eastern, Valley-Devers	Not modeled Energy Only	Market
SCE	DMDVLY_1_UNITS	25425	ESRP P2	6.9	1.64	8	LA Basin	Eastern	Aug NQC	QF/Selfgen
SCE	DREWS_6_PL1X4	25301	CLTNDREW	13.8	36.00	1	LA Basin	Eastern	Aug NQC	MUNI
SCE	DVLCYN_1_UNITS	25648	DVLCYN1G	13.8	39.40	1	LA Basin	Eastern	Aug NQC	MUNI
SCE	DVLCYN_1_UNITS	25649	DVLCYN2G	13.8	39.40	2	LA Basin	Eastern	Aug NQC	MUNI
SCE	DVLCYN_1_UNITS	25603	DVLCYN3G	13.8	52.54	3	LA Basin	Eastern	Aug NQC	MUNI

Attachment A - List of physical resources by PTO, local area and market ID

SCE	DVLCYN_1_UNITS	25604	DVLCYN4G	13.8	52.54	4	LA Basin	Eastern	Aug NQC	MUNI
SCE	ELLIS_2_QF	24325	ORCOGEN	13.8	0.04	1	LA Basin	Western	Aug NQC	QF/Selfgen
SCE	ELSEGN_2_UN1011	29904	ELSEG5GT	16.5	131.50	5	LA Basin	Western, El Nido	Aug NQC	Market
SCE	ELSEGN_2_UN1011	29903	ELSEG6ST	13.8	131.50	6	LA Basin	Western, El Nido	Aug NQC	Market
SCE	ELSEGN_2_UN2021	29902	ELSEG7GT	16.5	131.84	7	LA Basin	Western, El Nido	Aug NQC	Market
SCE	ELSEGN_2_UN2021	29901	ELSEG8ST	13.8	131.84	8	LA Basin	Western, El Nido	Aug NQC	Market
SCE	ETIWND_2_CHMPNE				0.00		LA Basin	Eastern	Not modeled Energy Only	Market
SCE	ETIWND_2_FONTNA	24055	ETIWANDA	66	0.22		LA Basin	Eastern	Not modeled Aug NQC	QF/Selfgen
SCE	ETIWND_2_RTS010	24055	ETIWANDA	66	0.62		LA Basin	Eastern	Not modeled Aug NQC	Market
SCE	ETIWND_2_RTS015	24055	ETIWANDA	66	1.23		LA Basin	Eastern	Not modeled Aug NQC	Market
SCE	ETIWND_2_RTS017	24055	ETIWANDA	66	1.44		LA Basin	Eastern	Not modeled Aug NQC	Market
SCE	ETIWND_2_RTS018	24055	ETIWANDA	66	0.62		LA Basin	Eastern	Not modeled Aug NQC	Market
SCE	ETIWND_2_RTS023	24055	ETIWANDA	66	1.03		LA Basin	Eastern	Not modeled Aug NQC	Market
SCE	ETIWND_2_RTS026	24055	ETIWANDA	66	2.46		LA Basin	Eastern	Not modeled Aug NQC	Market
SCE	ETIWND_2_RTS027	24055	ETIWANDA	66	0.82		LA Basin	Eastern	Not modeled Aug NQC	Market
SCE	ETIWND_2_SOLAR1				0.00		LA Basin	Eastern	Not modeled Energy Only	Solar
SCE	ETIWND_2_SOLAR2				0.00		LA Basin	Eastern	Not modeled Energy Only	Solar
SCE	ETIWND_2_SOLAR5				0.00		LA Basin	Eastern	Not modeled Energy Only	Solar
SCE	ETIWND_2_UNIT1	24071	INLAND	13.8	16.88	1	LA Basin	Eastern	Aug NQC	QF/Selfgen
SCE	ETIWND_6_GRPLND	29305	ETWPKGEN	13.8	46.00	1	LA Basin	Eastern		Market
SCE	ETIWND_6_MWDETI	25422	ETI MWDG	13.8	5.94	1	LA Basin	Eastern	Aug NQC	Market
SCE	GARNET_1_SOLAR	24815	GARNET	115	0.00		LA Basin	Eastern, Valley- Devers	Not modeled Energy Only	Solar
SCE	GARNET_1_SOLAR2	24815	GARNET	115	1.64		LA Basin	Eastern, Valley- Devers	Not modeled Aug NQC	Solar

Attachment A - List of physical resources by PTO, local area and market ID

SCE	GARNET_1_UNITS	24815	GARNET	115	2.06	G1	LA Basin	Eastern, Valley-Devers	Aug NQC	Market
SCE	GARNET_1_UNITS	24815	GARNET	115	0.71	G2	LA Basin	Eastern, Valley-Devers	Aug NQC	Market
SCE	GARNET_1_UNITS	24815	GARNET	115	1.61	G3	LA Basin	Eastern, Valley-Devers	Aug NQC	Market
SCE	GARNET_1_WIND	24815	GARNET	115	1.72		LA Basin	Eastern, Valley-Devers	Not modeled Aug NQC	Wind
SCE	GARNET_1_WINDS	24815	GARNET	115	5.96	W2	LA Basin	Eastern, Valley-Devers	Aug NQC	Wind
SCE	GARNET_1_WT3WWD	24815	GARNET	115	0.00	W3	LA Basin	Eastern, Valley-Devers	Aug NQC	Market
SCE	GARNET_2_DIFWD1	24815	GARNET	115	2.09		LA Basin	Eastern, Valley-Devers	Aug NQC	Market
SCE	GARNET_2_HYDRO	24815	GARNET	115	0.80	QF	LA Basin	Eastern, Valley-Devers	Aug NQC	Market
SCE	GARNET_2_WIND1	24815	GARNET	115	2.97		LA Basin	Eastern, Valley-Devers	Not modeled Aug NQC	Wind
SCE	GARNET_2_WIND2	24815	GARNET	115	3.10		LA Basin	Eastern, Valley-Devers	Not modeled Aug NQC	Wind
SCE	GARNET_2_WIND3	24815	GARNET	115	3.34		LA Basin	Eastern, Valley-Devers	Not modeled Aug NQC	Wind
SCE	GARNET_2_WIND4	24815	GARNET	115	2.60		LA Basin	Eastern, Valley-Devers	Not modeled Aug NQC	Wind
SCE	GARNET_2_WIND5	24815	GARNET	115	0.80		LA Basin	Eastern, Valley-Devers	Not modeled Aug NQC	Wind
SCE	GARNET_2_WPMWD6	24815	GARNET	115	1.57		LA Basin	Eastern, Valley-Devers	Not modeled Aug NQC	Wind
SCE	GLNARM_2_UNIT 5	29013	GLENARM5_C T	13.8	50.00	CT	LA Basin	Western		MUNI
SCE	GLNARM_2_UNIT 5	29014	GLENARM5_S T	13.8	15.00	ST	LA Basin	Western		MUNI
SCE	GLNARM_7_UNIT 1	29005	PASADNA1	13.8	22.07	1	LA Basin	Western		MUNI
SCE	GLNARM_7_UNIT 2	29006	PASADNA2	13.8	22.30	1	LA Basin	Western		MUNI
SCE	GLNARM_7_UNIT 3	25042	PASADNA3	13.8	44.83	1	LA Basin	Western		MUNI
SCE	GLNARM_7_UNIT 4	25043	PASADNA4	13.8	42.42	1	LA Basin	Western		MUNI
SCE	HARBGN_7_UNITS	24062	HARBOR G	13.8	76.27	1	LA Basin	Western		Market
SCE	HARBGN_7_UNITS	24062	HARBOR G	13.8	11.86	HP	LA Basin	Western		Market
SCE	HARBGN_7_UNITS	25510	HARBORG4	4.16	11.86	LP	LA Basin	Western		Market

Attachment A - List of physical resources by PTO, local area and market ID

SCE	HINSON_6_CARBGN	24020	CARBGEN1	13.8	14.78	1	LA Basin	Western	Aug NQC	Market
SCE	HINSON_6_CARBGN	24328	CARBGEN2	13.8	14.78	1	LA Basin	Western	Aug NQC	Market
SCE	HINSON_6_LBECH1	24170	LBEACH12	13.8	65.00	1	LA Basin	Western		Market
SCE	HINSON_6_LBECH2	24170	LBEACH12	13.8	65.00	2	LA Basin	Western		Market
SCE	HINSON_6_LBECH3	24171	LBEACH34	13.8	65.00	3	LA Basin	Western		Market
SCE	HINSON_6_LBECH4	24171	LBEACH34	13.8	65.00	4	LA Basin	Western		Market
SCE	HINSON_6_SERRGN	24139	SERRFGEN	13.8	28.93	D1	LA Basin	Western	Aug NQC	Market
SCE	HNTGBH_7_UNIT 1	24066	HUNT1 G	13.8	0.00	1	LA Basin	Western	Retired by 12/31/2019	Market
SCE	HNTGBH_7_UNIT 2	24067	HUNT2 G	13.8	225.80	2	LA Basin	Western	Retired by 2021	Market
SCE	INDIGO_1_UNIT 1	29190	WINTECX2	13.8	42.00	1	LA Basin	Eastern, Valley-Devers		Market
SCE	INDIGO_1_UNIT 2	29191	WINTECX1	13.8	42.00	1	LA Basin	Eastern, Valley-Devers		Market
SCE	INDIGO_1_UNIT 3	29180	WINTEC8	13.8	42.00	1	LA Basin	Eastern, Valley-Devers		Market
SCE	INLDEM_5_UNIT 1	29041	IIEEC-G1	19.5	335.00	1	LA Basin	Eastern, Valley, Valley-Devers	Aug NQC	Market
SCE	INLDEM_5_UNIT 2	29042	IIEEC-G2	19.5	335.00	1	LA Basin	Eastern, Valley, Valley-Devers	Mothballed	Market
SCE	LACIEN_2_VENICE	24337	VENICE	13.8	0.00	1	LA Basin	Western, El Nido	Aug NQC	MUNI
SCE	LAGBEL_6_QF	29951	REFUSE	13.8	0.35	D1	LA Basin	Western	Aug NQC	QF/Selfgen
SCE	LGHTHP_6_ICEGEN	24070	ICEGEN	13.8	48.00	1	LA Basin	Western	Aug NQC	QF/Selfgen
SCE	MESAS_2_QF	24209	MESA CAL	66	0.00		LA Basin	Western	Not modeled Aug NQC	QF/Selfgen
SCE	MIRLOM_2_CORONA				1.70		LA Basin	Eastern	Not modeled Aug NQC	QF/Selfgen
SCE	MIRLOM_2_LNDFL				1.23		LA Basin	Eastern	Not modeled Aug NQC	Market
SCE	MIRLOM_2_MLBBTA	25185	WDT1425_G1	0.48	10.00	1	LA Basin	Eastern	Aug NQC	Battery
SCE	MIRLOM_2_MLBBTB	25186	WDT1426_G2	0.48	10.00	1	LA Basin	Eastern	Aug NQC	Battery
SCE	MIRLOM_2_ONTARO				2.26		LA Basin	Eastern	Not modeled Aug NQC	Market
SCE	MIRLOM_2_RTS032				0.62		LA Basin	Eastern	Not modeled Aug NQC	Market
SCE	MIRLOM_2_RTS033				0.41		LA Basin	Eastern	Not modeled Aug NQC	Market

Attachment A - List of physical resources by PTO, local area and market ID

SCE	MIRLOM_2_TEMESC				1.07		LA Basin	Eastern	Not modeled Aug NQC	QF/Selfgen
SCE	MIRLOM_6_PEAKER	29307	MRLPKGEN	13.8	46.00	1	LA Basin	Eastern		Market
SCE	MIRLOM_7_MWDLKM	24210	MIRALOMA	66	5.00		LA Basin	Eastern	Not modeled Aug NQC	MUNI
SCE	MOJAVE_1_SIPHON	25657	MJVSPHN1	13.8	4.04	1	LA Basin	Eastern	Aug NQC	Market
SCE	MOJAVE_1_SIPHON	25658	MJVSPHN1	13.8	4.04	2	LA Basin	Eastern	Aug NQC	Market
SCE	MOJAVE_1_SIPHON	25659	MJVSPHN1	13.8	4.04	3	LA Basin	Eastern	Aug NQC	Market
SCE	MTWIND_1_UNIT 1	29060	MOUNTWND	115	11.77	S1	LA Basin	Eastern, Valley- Devers	Aug NQC	Wind
SCE	MTWIND_1_UNIT 2	29060	MOUNTWND	115	5.88	S2	LA Basin	Eastern, Valley- Devers	Aug NQC	Wind
SCE	MTWIND_1_UNIT 3	29060	MOUNTWND	115	5.95	S3	LA Basin	Eastern, Valley- Devers	Aug NQC	Wind
SCE	OLINDA_2_COYCRK	24211	OLINDA	66	3.13		LA Basin	Western	Not modeled	QF/Selfgen
SCE	OLINDA_2_LNDFL2	29011	BREAPWR2	13.8	4.07	C1	LA Basin	Western	Aug NQC	Market
SCE	OLINDA_2_LNDFL2	29011	BREAPWR2	13.8	4.07	C2	LA Basin	Western	Aug NQC	Market
SCE	OLINDA_2_LNDFL2	29011	BREAPWR2	13.8	4.07	C3	LA Basin	Western	Aug NQC	Market
SCE	OLINDA_2_LNDFL2	29011	BREAPWR2	13.8	4.07	C4	LA Basin	Western	Aug NQC	Market
SCE	OLINDA_2_LNDFL2	29011	BREAPWR2	13.8	7.28	S1	LA Basin	Western	Aug NQC	Market
SCE	OLINDA_2_QF	24211	OLINDA	66	0.01		LA Basin	Western	Not modeled Aug NQC	QF/Selfgen
SCE	OLINDA_7_BLKSNL	24211	OLINDA	66	0.41		LA Basin	Western	Not modeled Aug NQC	Market
SCE	OLINDA_7_LNDFIL	24211	OLINDA	66	0.00		LA Basin	Western	Not modeled Aug NQC	QF/Selfgen
SCE	PADUA_2_ONTARO	24111	PADUA	66	0.35		LA Basin	Eastern	Not modeled Aug NQC	QF/Selfgen
SCE	PADUA_2_SOLAR1	24111	PADUA	66	0.00		LA Basin	Eastern	Not modeled Energy Only	Solar
SCE	PADUA_6_MWDSM	24111	PADUA	66	2.74		LA Basin	Eastern	Not modeled Aug NQC	MUNI
SCE	PADUA_6_QF	24111	PADUA	66	0.38		LA Basin	Eastern	Not modeled Aug NQC	QF/Selfgen
SCE	PADUA_7_SDIMAS	24111	PADUA	66	1.05		LA Basin	Eastern	Not modeled Aug NQC	Market
SCE	PANSEA_1_PANARO	25640	PANAERO	115	7.95	QF	LA Basin	Eastern, Valley- Devers	Aug NQC	Wind

Attachment A - List of physical resources by PTO, local area and market ID

SCE	PWEST_1_UNIT	24815	GARNET	115	0.56	PC	LA Basin	Western	Aug NQC	Market
SCE	REDOND_7_UNIT 5	24121	REDON5 G	18	178.87	5	LA Basin	Western	Retired by 2021	Market
SCE	REDOND_7_UNIT 6	24122	REDON6 G	18	175.00	6	LA Basin	Western	Retired by 2021	Market
SCE	REDOND_7_UNIT 7	24123	REDON7 G	20	0.00	7	LA Basin	Western	Retired by 12/31/2019	Market
SCE	REDOND_7_UNIT 8	24124	REDON8 G	20	495.90	8	LA Basin	Western	Retired by 2021	Market
SCE	RENWD_1_QF	25636	RENWIND	115	1.33	Q1	LA Basin	Eastern, Valley-Devers	Aug NQC	QF/Selfgen
SCE	RENWD_1_QF	25636	RENWIND	115	1.32	Q2	LA Basin	Eastern, Valley-Devers	Aug NQC	QF/Selfgen
SCE	RHONDO_6_PUENTE	24213	RIOHONDO	66	0.00		LA Basin	Western	Not modeled Aug NQC	Net Seller
SCE	RVSIIDE_2_RERCU3	24299	RERC2G3	13.8	48.50	1	LA Basin	Eastern		MUNI
SCE	RVSIIDE_2_RERCU4	24300	RERC2G4	13.8	48.50	1	LA Basin	Eastern		MUNI
SCE	RVSIIDE_6_RERCU1	24242	RERC1G	13.8	48.35	1	LA Basin	Eastern		MUNI
SCE	RVSIIDE_6_RERCU2	24243	RERC2G	13.8	48.50	1	LA Basin	Eastern		MUNI
SCE	RVSIIDE_6_SOLAR1	24244	SPRINGEN	13.8	3.08		LA Basin	Eastern	Not modeled Aug NQC	Solar
SCE	RVSIIDE_6_SPRING	24244	SPRINGEN	13.8	36.00	1	LA Basin	Eastern		Market
SCE	SANITR_6_UNITS	24324	SANIGEN	13.8	42.00	D1	LA Basin	Eastern	Aug NQC	QF/Selfgen
SCE	SANTGO_2_LNDFL1	24341	COYGEN	13.8	19.16	1	LA Basin	Western	Aug NQC	Market
SCE	SANTGO_2_MABBT1	25192	WDT1406_G	0.48	2.00	1	LA Basin	Western	Aug NQC	Battery
SCE	SANWD_1_QF	25646	SANWIND	115	4.11	Q1	LA Basin	Eastern, Valley-Devers	Aug NQC	Wind
SCE	SANWD_1_QF	25646	SANWIND	115	4.11	Q2	LA Basin	Eastern, Valley-Devers	Aug NQC	Wind
SCE	SBERDO_2_PSP3	24921	MNTV-CT1	18	140.56	1	LA Basin	Eastern, West of Devers		Market
SCE	SBERDO_2_PSP3	24922	MNTV-CT2	18	140.56	1	LA Basin	Eastern, West of Devers		Market
SCE	SBERDO_2_PSP3	24923	MNTV-ST1	18	243.89	1	LA Basin	Eastern, West of Devers		Market
SCE	SBERDO_2_PSP4	24924	MNTV-CT3	18	140.56	1	LA Basin	Eastern, West of Devers		Market

Attachment A - List of physical resources by PTO, local area and market ID

SCE	SBERDO_2_PSP4	24925	MNTV-CT4	18	140.56	1	LA Basin	Eastern, West of Devers		Market
SCE	SBERDO_2_PSP4	24926	MNTV-ST2	18	243.89	1	LA Basin	Eastern, West of Devers		Market
SCE	SBERDO_2_QF	24214	SANBRDNO	66	0.26		LA Basin	Eastern, West of Devers	Not modeled Aug NQC	QF/Selfgen
SCE	SBERDO_2_REDLND	24214	SANBRDNO	66	0.82		LA Basin	Eastern, West of Devers	Not modeled Aug NQC	Market
SCE	SBERDO_2_RTS005	24214	SANBRDNO	66	1.03		LA Basin	Eastern, West of Devers	Not modeled Aug NQC	Market
SCE	SBERDO_2_RTS007	24214	SANBRDNO	66	1.03		LA Basin	Eastern, West of Devers	Not modeled Aug NQC	Market
SCE	SBERDO_2_RTS011	24214	SANBRDNO	66	1.44		LA Basin	Eastern, West of Devers	Not modeled Aug NQC	Market
SCE	SBERDO_2_RTS013	24214	SANBRDNO	66	1.44		LA Basin	Eastern, West of Devers	Not modeled Aug NQC	Market
SCE	SBERDO_2_RTS016	24214	SANBRDNO	66	0.62		LA Basin	Eastern, West of Devers	Not modeled Aug NQC	Market
SCE	SBERDO_2_RTS048	24214	SANBRDNO	66	0.00		LA Basin	Eastern, West of Devers	Not modeled Energy Only	Market
SCE	SBERDO_2_SNTANA	24214	SANBRDNO	66	0.32		LA Basin	Eastern, West of Devers	Not modeled Aug NQC	QF/Selfgen
SCE	SBERDO_6_MILLCK	24214	SANBRDNO	66	1.04		LA Basin	Eastern, West of Devers	Not modeled Aug NQC	QF/Selfgen
SCE	SENTNL_2_CTG1	29101	SENTINEL_G1	13.8	103.76	1	LA Basin	Eastern, Valley-Devers		Market
SCE	SENTNL_2_CTG2	29102	SENTINEL_G2	13.8	95.34	1	LA Basin	Eastern, Valley-Devers		Market
SCE	SENTNL_2_CTG3	29103	SENTINEL_G3	13.8	96.85	1	LA Basin	Eastern, Valley-Devers		Market
SCE	SENTNL_2_CTG4	29104	SENTINEL_G4	13.8	102.47	1	LA Basin	Eastern, Valley-Devers		Market
SCE	SENTNL_2_CTG5	29105	SENTINEL_G5	13.8	103.81	1	LA Basin	Eastern, Valley-Devers		Market
SCE	SENTNL_2_CTG6	29106	SENTINEL_G6	13.8	100.99	1	LA Basin	Eastern, Valley-Devers		Market
SCE	SENTNL_2_CTG7	29107	SENTINEL_G7	13.8	97.06	1	LA Basin	Eastern, Valley-Devers		Market
SCE	SENTNL_2_CTG8	29108	SENTINEL_G8	13.8	101.80	1	LA Basin	Eastern, Valley-Devers		Market

Attachment A - List of physical resources by PTO, local area and market ID

SCE	TIFFNY_1_DILLON	29021	WINTEC6	115	11.93	1	LA Basin	Eastern, Valley-Devers	Aug NQC	Wind
SCE	TRNSWD_1_QF	25637	TRANWIND	115	10.33	QF	LA Basin	Eastern, Valley-Devers	Aug NQC	Wind
SCE	TULEWD_1_TULWD1				33.81		LA Basin	Eastern, Valley-Devers	Not modeled Aug NQC	Wind
SCE	VALLEY_5_PERRIS	24160	VALLEYSC	115	7.94		LA Basin	Eastern, Valley, Valley-Devers	Not modeled Aug NQC	QF/Selfgen
SCE	VALLEY_5_REDMTN	24160	VALLEYSC	115	3.50		LA Basin	Eastern, Valley, Valley-Devers	Not modeled Aug NQC	QF/Selfgen
SCE	VALLEY_5_RTS044	24160	VALLEYSC	115	3.28		LA Basin	Eastern, Valley, Valley-Devers	Not modeled Aug NQC	Market
SCE	VALLEY_5_SOLAR1	24160	VALLEYSC	115	0.00		LA Basin	Eastern, Valley, Valley-Devers	Not modeled Energy Only	Solar
SCE	VALLEY_5_SOLAR2	25082	WDT786	34.5	8.20	EQ	LA Basin	Eastern, Valley, Valley-Devers	Aug NQC	Solar
SCE	VENWD_1_WIND1	25645	VENWIND	115	2.50	Q1	LA Basin	Eastern, Valley-Devers	Aug NQC	QF/Selfgen
SCE	VENWD_1_WIND2	25645	VENWIND	115	4.25	Q2	LA Basin	Eastern, Valley-Devers	Aug NQC	QF/Selfgen
SCE	VENWD_1_WIND3	25645	VENWIND	115	5.05	EU	LA Basin	Eastern, Valley-Devers	Aug NQC	QF/Selfgen
SCE	VERNON_6_GONZL1	24342	FEDGEN	13.8	5.75	1	LA Basin	Western		MUNI
SCE	VERNON_6_GONZL2	24342	FEDGEN	13.8	5.75	1	LA Basin	Western		MUNI
SCE	VERNON_6_MALBRG	24239	MALBRG1G	13.8	42.37	C1	LA Basin	Western		MUNI
SCE	VERNON_6_MALBRG	24240	MALBRG2G	13.8	42.37	C2	LA Basin	Western		MUNI
SCE	VERNON_6_MALBRG	24241	MALBRG3G	13.8	49.26	S3	LA Basin	Western		MUNI
SCE	VILLPK_2_VALLYV	24216	VILLA PK	66	4.10	DG	LA Basin	Western	Aug NQC	QF/Selfgen
SCE	VILLPK_6_MWDYOR	24216	VILLA PK	66	3.99		LA Basin	Western	Not modeled Aug NQC	MUNI
SCE	VISTA_2_RIALTO	24901	VSTA	230	0.41		LA Basin	Eastern	Not modeled	Market
SCE	VISTA_2_RTS028	24901	VSTA	230	1.44		LA Basin	Eastern	Not modeled Aug NQC	Market
SCE	VISTA_6_QF	24902	VSTA	66	0.06		LA Basin	Eastern	Not modeled Aug NQC	QF/Selfgen
SCE	WALCRK_2_CTG1	29201	WALCRKG1	13.8	96.00	1	LA Basin	Western		Market
SCE	WALCRK_2_CTG2	29202	WALCRKG2	13.8	96.00	1	LA Basin	Western		Market
SCE	WALCRK_2_CTG3	29203	WALCRKG3	13.8	96.00	1	LA Basin	Western		Market

Attachment A - List of physical resources by PTO, local area and market ID

SCE	WALCRK_2_CTG4	29204	WALCRKG4	13.8	96.00	1	LA Basin	Western		Market
SCE	WALCRK_2_CTG5	29205	WALCRKG5	13.8	96.65	1	LA Basin	Western		Market
SCE	WALNUT_2_SOLAR				0.00		LA Basin	Western	Not modeled Energy Only	Solar
SCE	WALNUT_6_HILLGEN	24063	HILLGEN	13.8	39.44	D1	LA Basin	Western	Aug NQC	Net Seller
SCE	WALNUT_7_WCOVCT	24157	WALNUT	66	3.45		LA Basin	Western	Not modeled Aug NQC	Market
SCE	WALNUT_7_WCOVST	24157	WALNUT	66	5.61		LA Basin	Western	Not modeled Aug NQC	Market
SCE	WHTWTR_1_WINDA1	29061	WHITEWTR	33	16.30	1	LA Basin	Eastern, Valley- Devers	Aug NQC	Wind
SCE	ZZ_ARCOGN_2_UNITS	24018	BRIGEN	13.8	0.00	1	LA Basin	Western	No NQC - hist. data	Net Seller
SCE	ZZ_HINSON_6_QF	24064	HINSON	66	0.00	1	LA Basin	Western	No NQC - hist. data	QF/Selfgen
SCE	ZZ_LAFRES_6_QF	24332	PALOGEN	13.8	0.00	D1	LA Basin	Western, El Nido	No NQC - hist. data	QF/Selfgen
SCE	ZZ_MOBGEN_6_UNIT 1	24094	MOBGEN	13.8	0.00	1	LA Basin	Western, El Nido	No NQC - hist. data	QF/Selfgen
SCE	ZZ_NA	24327	THUMSGEN	13.8	0.00	1	LA Basin	Western	No NQC - hist. data	QF/Selfgen
SCE	ZZ_NA	24329	MOBGEN2	13.8	0.00	1	LA Basin	Western, El Nido	No NQC - hist. data	QF/Selfgen
SCE	ZZ_NA	24330	OUTFALL1	13.8	0.00	1	LA Basin	Western, El Nido	No NQC - hist. data	QF/Selfgen
SCE	ZZ_NA	24331	OUTFALL2	13.8	0.00	1	LA Basin	Western, El Nido	No NQC - hist. data	QF/Selfgen
SCE	ZZ_NA	29260	ALTAMSA4	115	0.00	1	LA Basin	Eastern, Valley- Devers	No NQC - hist. data	Wind
SCE	ZZZ_New	97624	WH_STN_1	13.8	49.00	1	LA Basin	Western	No NQC - Pmax	Market
SCE	ZZZ_New	97625	WH_STN_2	13.8	49.00	1	LA Basin	Western	No NQC - Pmax	Market
SCE	ZZZ_New	24575	ALMT CTG1	18	200.00	G1	LA Basin	Western	No NQC - Pmax	Market
SCE	ZZZ_New	24580	HUNTBCH CTG1	18	202.00	G1	LA Basin	Western	No NQC - Pmax	Market
SCE	ZZZ_New	24576	ALMT CTG2	18	200.00	G2	LA Basin	Western	No NQC - Pmax	Market

Attachment A - List of physical resources by PTO, local area and market ID

SCE	ZZZ_New	24581	HUNTBCH CTG2	18	202.00	G2	LA Basin	Western	No NQC - Pmax	Market
SCE	ZZZ_New	24577	ALMT STG	18	240.00	S1	LA Basin	Western	No NQC - Pmax	Market
SCE	ZZZ_New	24582	HUNTBCH STG	18	240.00	S1	LA Basin	Western	No NQC - Pmax	Market
SCE	ZZZZZ_BRDWAY_7_UNIT 3	29007	BRODWYSC	13.8	0.00		LA Basin	Western	Retired	MUNI
SCE	ZZZZZ_CENTER_2_QF	29953	SIGGEN	13.8	0.00	D1	LA Basin	Western	Aug NQC	QF/Selfgen
SCE	ZZZZZ_ETIWND_7_MIDVLY	24055	ETIWANDA	66	0.00		LA Basin	Eastern	Not modeled Aug NQC	QF/Selfgen
SCE	ZZZZZ_ETIWND_7_UNIT 3	24052	MTNVIST3	18	0.00	3	LA Basin	Eastern	Retired	Market
SCE	ZZZZZ_ETIWND_7_UNIT 4	24053	MTNVIST4	18	0.00	4	LA Basin	Eastern	Retired	Market
SCE	ZZZZZ_LAGBEL_2_STG1				0.00		LA Basin	Western	Retired	Market
SCE	ZZZZZ_MIRLOM_6_DELGEN	29339	DELGEN	13.8	0.00	1	LA Basin	Eastern	Aug NQC	QF/Selfgen
SCE	ZZZZZ_RHONDO_2_QF	24213	RIOHONDO	66	0.00	DG	LA Basin	Western	Aug NQC	QF/Selfgen
SCE	ZZZZZ_VALLEY_7_BADLND	24160	VALLEYSC	115	0.00		LA Basin	Eastern, Valley, Valley-Devers	Retired	Market
SCE	ZZZZZ_VALLEY_7_UNITA 1	24160	VALLEYSC	115	0.00		LA Basin	Eastern, Valley, Valley-Devers	Not modeled Aug NQC	Market
SCE	ZZZZZZ_ELSEGN_7_UNIT 4	24048	ELSEG4 G	18	0.00	4	LA Basin	Western, El Nido	Retired	Market
SDG&E	BORDER_6_UNITA1	22149	CALPK_BD	13.8	48.00	1	SD-IV	San Diego, Border		Market
SDG&E	BREGGO_6_DEGRSL	22085	BORREGO	12.5	2.58	DG	SD-IV	San Diego	Aug NQC	Solar
SDG&E	BREGGO_6_SOLAR	22082	BR GEN1	0.21	10.66	1	SD-IV	San Diego	Aug NQC	Solar
SDG&E	CARLS1_2_CARCT1	22783	EA5 REPOWER1	13.8	105.50	1	SD-IV	San Diego	Aug NQC	Market
SDG&E	CARLS1_2_CARCT1	22784	EA5 REPOWER2	13.8	105.50	1	SD-IV	San Diego	Aug NQC	Market
SDG&E	CARLS1_2_CARCT1	22786	EA5 REPOWER4	13.8	105.50	1	SD-IV	San Diego	Aug NQC	Market
SDG&E	CARLS1_2_CARCT1	22788	EA5 REPOWER3	13.8	105.50	1	SD-IV	San Diego	Aug NQC	Market
SDG&E	CARLS2_1_CARCT1	22787	EA5 REPOWER5	13.8	105.50	1	SD-IV	San Diego	Aug NQC	Market

Attachment A - List of physical resources by PTO, local area and market ID

SDG&E	CCRITA_7_RPPCHF	22124	CHCARITA	138	2.31	1	SD-IV	San Diego	Aug NQC	Market
SDG&E	CHILLS_1_SYCENG	22120	CARLTNHS	138	0.71	1	SD-IV	San Diego	Aug NQC	QF/Selfgen
SDG&E	CHILLS_7_UNITA1	22120	CARLTNHS	138	1.52	2	SD-IV	San Diego	Aug NQC	QF/Selfgen
SDG&E	CNTNLA_2_SOLAR1	23463	DW GEN3&4	0.33	51.25	1	SD-IV		Aug NQC	Solar
SDG&E	CNTNLA_2_SOLAR2	23463	DW GEN3&4	0.33	0.00	2	SD-IV		Energy Only	Solar
SDG&E	CPSTNO_7_PRMA DS	22112	CAPSTRNO	138	5.88	1	SD-IV	San Diego	Aug NQC	Market
SDG&E	CPVERD_2_SOLAR	23309	IV GEN3 G1	0.31	31.66	G1	SD-IV		Aug NQC	Solar
SDG&E	CPVERD_2_SOLAR	23301	IV GEN3 G2	0.31	25.33	G2	SD-IV		Aug NQC	Solar
SDG&E	CRELMN_6_RAMON1	22152	CREELMAN	69	0.82	DG	SD-IV	San Diego	Aug NQC	Solar
SDG&E	CRELMN_6_RAMON2	22152	CREELMAN	69	2.05	DG	SD-IV	San Diego	Aug NQC	Solar
SDG&E	CRELMN_6_RAMSR3				1.42		SD-IV	San Diego	Not modeled Aug NQC	Solar
SDG&E	CRSTWD_6_KUMYAY	22915	KUMEYAAY	0.69	13.25	1	SD-IV	San Diego	Aug NQC	Wind
SDG&E	CSLR4S_2_SOLAR	23298	DW GEN1 G1	0.31 5	26.65	G1	SD-IV		Aug NQC	Solar
SDG&E	CSLR4S_2_SOLAR	23299	DW GEN1 G2	0.31 5	26.65	G2	SD-IV		Aug NQC	Solar
SDG&E	ELCAJN_6_EB1BT1	22208	EL CAJON	69	7.50	1	SD-IV	San Diego, El Cajon		Battery
SDG&E	ELCAJN_6_LM6K	23320	EC GEN2	13.8	48.10	1	SD-IV	San Diego, El Cajon		Market
SDG&E	ELCAJN_6_UNITA1	22150	EC GEN1	13.8	45.42	1	SD-IV	San Diego, El Cajon		Market
SDG&E	ENERSJ_2_WIND	23100	ECO GEN1 G1	0.69	41.10	G1	SD-IV		Aug NQC	Wind
SDG&E	ESCND0_6_EB1BT1	22256	ESCNDIDO	69	10.00	1	SD-IV	San Diego, Esco		Battery
SDG&E	ESCND0_6_EB2BT2	22256	ESCNDIDO	69	10.00	1	SD-IV	San Diego, Esco		Battery
SDG&E	ESCND0_6_EB3BT3	22256	ESCNDIDO	69	10.00	1	SD-IV	San Diego, Esco		Battery
SDG&E	ESCND0_6_PL1X2	22257	ESGEN	13.8	48.71	1	SD-IV	San Diego, Esco		Market
SDG&E	ESCND0_6_UNITB1	22153	CALPK_ES	13.8	48.00	1	SD-IV	San Diego, Esco		Market
SDG&E	ESCO_6_GLMQF	22332	GOALLINE	69	36.41	1	SD-IV	San Diego, Esco	Aug NQC	Net Seller
SDG&E	IVSLRP_2_SOLAR1	23440	DW GEN2 G1	0.36	82.00	1	SD-IV		Aug NQC	Solar
SDG&E	IWEST_2_SOLAR1	23155	DU GEN1 G1	0.2	33.27	G1	SD-IV		Aug NQC	Solar
SDG&E	IWEST_2_SOLAR1	23156	DU GEN1 G2	0.2	28.23	G2	SD-IV		Aug NQC	Solar
SDG&E	JACMSR_1_JACSR1	23352	ECO GEN2	0.55	8.20	1	SD-IV		Aug NQC	Solar
SDG&E	LAKHDG_6_UNIT 1	22625	LKHODG1	13.8	20.00	1	SD-IV	San Diego, Esco		Market
SDG&E	LAKHDG_6_UNIT 2	22626	LKHODG2	13.8	20.00	2	SD-IV	San Diego, Esco		Market

Attachment A - List of physical resources by PTO, local area and market ID

SDG&E	LARKSP_6_UNIT 1	22074	LRKSPBD1	13.8	46.00	1	SD-IV	San Diego, Border		Market
SDG&E	LARKSP_6_UNIT 2	22075	LRKSPBD2	13.8	46.00	1	SD-IV	San Diego, Border		Market
SDG&E	LAROA1_2_UNITA1	20187	LRP-U1	16	0.00	1	SD-IV		Connect to GENACE/CF E grid for the summer – not available for ISO BAA RA purpose	Market
SDG&E	LAROA2_2_UNITA1	22996	INTBST	18	145.19	1	SD-IV			Market
SDG&E	LAROA2_2_UNITA1	22997	INTBCT	16	176.81	1	SD-IV			Market
SDG&E	LILIAC_6_SOLAR	22404	LILIAC	69	1.23	DG	SD-IV	San Diego		Solar
SDG&E	MRGT_6_MEF2	22487	MEF_MR2	13.8	44.00	1	SD-IV	San Diego		Market
SDG&E	MRGT_6_MMAREF	22486	MEF_MR1	13.8	45.00	1	SD-IV	San Diego		Market
SDG&E	MSHGTS_6_MMARLF	22448	MESAHGTS	69	4.37	1	SD-IV	San Diego, Mission	Aug NQC	Market
SDG&E	MSSION_2_QF	22496	MISSION	69	0.65	1	SD-IV	San Diego	Aug NQC	Market
SDG&E	MURRAY_6_UNIT	22532	MURRAY	69	0.00		SD-IV	San Diego	Not modeled Energy Only	Market
SDG&E	OCTILO_5_WIND	23314	OCO GEN G1	0.69	35.12	G1	SD-IV		Aug NQC	Wind
SDG&E	OCTILO_5_WIND	23318	OCO GEN G2	0.69	35.12	G2	SD-IV		Aug NQC	Wind
SDG&E	OGROVE_6_PL1X2	22628	PA GEN1	13.8	48.00	1	SD-IV	San Diego, Pala Inner, Pala Outer		Market
SDG&E	OGROVE_6_PL1X2	22629	PA GEN2	13.8	48.00	1	SD-IV	San Diego, Pala Inner, Pala Outer		Market
SDG&E	OTAY_6_LNDFL5	22604	OTAY	69	0.00		SD-IV	San Diego, Border	Not modeled Energy Only	Market
SDG&E	OTAY_6_LNDFL6	22604	OTAY	69	0.00		SD-IV	San Diego, Border	Not modeled Energy Only	Market
SDG&E	OTAY_6_PL1X2	22617	OYGEN	13.8	35.50	1	SD-IV	San Diego, Border		Market
SDG&E	OTAY_6_UNITB1	22604	OTAY	69	2.03	1	SD-IV	San Diego, Border	Aug NQC	Market
SDG&E	OTMESA_2_PL1X3	22605	OTAYMGT1	18	165.16	1	SD-IV	San Diego		Market
SDG&E	OTMESA_2_PL1X3	22606	OTAYMGT2	18	166.17	1	SD-IV	San Diego		Market
SDG&E	OTMESA_2_PL1X3	22607	OTAYMST1	16	272.27	1	SD-IV	San Diego		Market
SDG&E	PALOMR_2_PL1X3	22262	PEN_CT1	18	170.18	1	SD-IV	San Diego		Market
SDG&E	PALOMR_2_PL1X3	22263	PEN_CT2	18	170.18	1	SD-IV	San Diego		Market
SDG&E	PALOMR_2_PL1X3	22265	PEN_ST	18	225.24	1	SD-IV	San Diego		Market

Attachment A - List of physical resources by PTO, local area and market ID

SDG&E	PIOPIC_2_CTG1	23162	PIO PICO CT1	13.8	106.00	1	SD-IV	San Diego	No NQC - Pmax	Market
SDG&E	PIOPIC_2_CTG2	23163	PIO PICO CT2	13.8	106.00	1	SD-IV	San Diego	No NQC - Pmax	Market
SDG&E	PIOPIC_2_CTG3	23164	PIO PICO CT3	13.8	106.00	1	SD-IV	San Diego	No NQC - Pmax	Market
SDG&E	PTLOMA_6_NTCCGN	22660	POINTLMA	69	2.23	2	SD-IV	San Diego	Aug NQC	QF/Selfgen
SDG&E	SAMPSN_6_KELCO1	22704	SAMPSON	12.5	3.06	1	SD-IV	San Diego	Aug NQC	Net Seller
SDG&E	SMRCOS_6_LNDFIL	22724	SANMRCOS	69	1.50	1	SD-IV	San Diego	Aug NQC	Market
SDG&E	TERMEX_2_PL1X3	22982	TDM CTG2	18	156.44	1	SD-IV			Market
SDG&E	TERMEX_2_PL1X3	22983	TDM CTG3	18	156.44	1	SD-IV			Market
SDG&E	TERMEX_2_PL1X3	22981	TDM STG	21	280.13	1	SD-IV			Market
SDG&E	VLCNTR_6_VCCLR	22870	VALCNTR	69	0.96	DG	SD-IV	San Diego, Esco	Aug NQC	Solar
SDG&E	VLCNTR_6_VCCLR1	22870	VALCNTR	69	1.03	DG	SD-IV	San Diego, Esco	Aug NQC	Solar
SDG&E	VLCNTR_6_VCCLR2	22870	VALCNTR	69	2.05	DG	SD-IV	San Diego, Esco	Aug NQC	Solar
SDG&E	VSTAES_6_VESBT1	23541	Q1061_BESS	0.48	5.50	1	SD-IV	San Diego, Pala Outer	No NQC - est. data	Battery
SDG&E	VSTAES_6_VESBT1	23216	Q1294_BESS	0.48	5.50	C9	SD-IV	San Diego, Pala Outer	No NQC - est. data	Battery
SDG&E	WISTRA_2_WRSSR1	23287	Q429_G1	0.31	41.00	1	SD-IV		Aug NQC	Solar
SDG&E	ZZ_NA	22916	PFC-AVC	0.6	0.00	1	SD-IV	San Diego	No NQC - hist. data	QF/Selfgen
SDG&E	ZZZ_New Unit	23597	Q1175_BESS	0.48	0.00	1	SD-IV		Energy Only	Battery
SDG&E	ZZZ_New Unit	23441	DW GEN2 G2	0.42	61.60	1	SD-IV		Aug NQC	Solar
SDG&E	ZZZ_New Unit	23710	Q1170_BESS	0.48	62.50	1	SD-IV	San Diego	No NQC - Pmax	Battery
SDG&E	ZZZ_New Unit	22942	BUE GEN 1_G1	0.69	11.60	G1	SD-IV		No NQC - est. data	Wind
SDG&E	ZZZ_New Unit	22945	BUE GEN 1_G2	0.69	11.60	G2	SD-IV		No NQC - est. data	Wind
SDG&E	ZZZ_New Unit	22947	BUE GEN 1_G3	0.69	11.60	G3	SD-IV		No NQC - est. data	Wind
SDG&E	ZZZ_New Unit	22949	BUE GEN 1_G4	0.69	26.00	G3	SD-IV		No NQC - est. data	Wind
SDG&E	ZZZ_New Unit	22020	AVOCADO	69	2.00	S2	SD-IV	San Diego, Pala Inner, Pala Outer	No NQC - Pmax	Battery
SDG&E	ZZZZ_CBRLLLO_6_PLSTP 1	22092	CABRILLO	69	0.00	1	SD-IV	San Diego	Aug NQC	Market

Attachment A - List of physical resources by PTO, local area and market ID

SDG&E	ZZZZ_DIVSON_6_NSQF	22172	DIVISION	69	0.00	1	SD-IV	San Diego	Retired	QF/Selfgen
SDG&E	ZZZZ_ELCAJN_7_GT1	22212	ELCAJNGT	12.5	0.00	1	SD-IV	San Diego, El Cajon	Retired	Market
SDG&E	ZZZZ_ENCINA_7_EA1	22233	ENCINA 1	14.4	0.00	1	SD-IV	San Diego, Encina	Retired	Market
SDG&E	ZZZZ_ENCINA_7_EA2	22234	ENCINA 2	14.4	0.00	1	SD-IV	San Diego, Encina	Retired by 2019	Market
SDG&E	ZZZZ_ENCINA_7_EA3	22236	ENCINA 3	14.4	0.00	1	SD-IV	San Diego, Encina	Retired by 2019	Market
SDG&E	ZZZZ_ENCINA_7_EA4	22240	ENCINA 4	22	0.00	1	SD-IV	San Diego, Encina	Retired by 2019	Market
SDG&E	ZZZZ_ENCINA_7_EA5	22244	ENCINA 5	24	0.00	1	SD-IV	San Diego, Encina	Retired by 2019	Market
SDG&E	ZZZZ_ENCINA_7_GT1	22248	ENCINAGT	12.5	0.00	1	SD-IV	San Diego, Encina	Retired by 2019	Market
SDG&E	ZZZZ_KEARNY_7_KY2	22373	KEARN2AB	12.5	0.00	1	SD-IV	San Diego, Mission	Retired	Market
SDG&E	ZZZZ_KEARNY_7_KY2	22374	KEARN2CD	12.5	0.00	1	SD-IV	San Diego, Mission	Retired	Market
SDG&E	ZZZZ_KEARNY_7_KY2	22373	KEARN2AB	12.5	0.00	2	SD-IV	San Diego, Mission	Retired	Market
SDG&E	ZZZZ_KEARNY_7_KY2	22374	KEARN2CD	12.5	0.00	2	SD-IV	San Diego, Mission	Retired	Market
SDG&E	ZZZZ_KEARNY_7_KY3	22375	KEARN3AB	12.5	0.00	1	SD-IV	San Diego, Mission	Retired	Market
SDG&E	ZZZZ_KEARNY_7_KY3	22376	KEARN3CD	12.5	0.00	1	SD-IV	San Diego, Mission	Retired	Market
SDG&E	ZZZZ_KEARNY_7_KY3	22375	KEARN3AB	12.5	0.00	2	SD-IV	San Diego, Mission	Retired	Market
SDG&E	ZZZZ_KEARNY_7_KY3	22376	KEARN3CD	12.5	0.00	2	SD-IV	San Diego, Mission	Retired	Market
SDG&E	ZZZZ_MRGT_7_UNITS	22488	MIRAMRGT	12.5	0.00	1	SD-IV	San Diego	Retired	Market
SDG&E	ZZZZ_MRGT_7_UNITS	22488	MIRAMRGT	12.5	0.00	2	SD-IV	San Diego	Retired	Market
SDG&E	ZZZZ_NIMTG_6_NIQF	22576	NOISLMTR	69	0.00	1	SD-IV	San Diego	Retired	QF/Selfgen
SDG&E	ZZZZ_OTAY_7_UNITC1	22604	OTAY	69	0.00	3	SD-IV	San Diego, Border	Aug NQC	QF/Selfgen
SDG&E	ZZZZ_PTLOMA_6_NTCQ F	22660	POINTLMA	69	0.00	1	SD-IV	San Diego	Retired	QF/Selfgen

o

Attachment B – Effectiveness factors for procurement guidance

Table - Eagle Rock.

Effectiveness factors to the Eagle Rock-Cortina 115 kV line:

Gen Bus	Gen Name	Gen ID	Eff Factor (%)
31406	GEYSR5-6	1	36
31406	GEYSR5-6	2	36
31408	GEYSER78	1	36
31408	GEYSER78	2	36
31412	GEYSER11	1	37
31435	GEO.ENGY	1	35
31435	GEO.ENGY	2	35
31433	POTTRVLY	1	34
31433	POTTRVLY	3	34
31433	POTTRVLY	4	34
38020	CITY UKH	1	32
38020	CITY UKH	2	32

Table - Fulton

Effectiveness factors to the Lakeville-Petaluma-Cotati 60 kV line:

Gen Bus	Gen Name	Gen ID	Eff Factor (%)
31466	SONMA LF	1	52
31422	GEYSER17	1	12
31404	WEST FOR	1	12
31404	WEST FOR	2	12
31414	GEYSER12	1	12
31418	GEYSER14	1	12
31420	GEYSER16	1	12
31402	BEAR CAN	1	12
31402	BEAR CAN	2	12

Attachment B – Effectiveness factors for procurement guidance

Gen Bus	Gen Name	Gen ID	Eff Factor (%)
38110	NCPA2GY1	1	12
38112	NCPA2GY2	1	12
32700	MONTICLO	1	10
32700	MONTICLO	2	10
32700	MONTICLO	3	10
31435	GEO.ENGY	1	6
31435	GEO.ENGY	2	6
31408	GEYSER78	1	6
31408	GEYSER78	2	6
31412	GEYSER11	1	6
31406	GEYSR5-6	1	6
31406	GEYSR5-6	2	6

Table – North Coast and North Bay

Effectiveness factors to the Vaca Dixon-Lakeville 230 kV line:

Gen Bus	Gen Name	Gen ID	Eff Factor (%)
31400	SANTA FE	2	38
31430	SMUDGE01	1	38
31400	SANTA FE	1	38
31416	GEYSER13	1	38
31424	GEYSER18	1	38
31426	GEYSER20	1	38
38106	NCPA1GY1	1	38
38108	NCPA1GY2	1	38
31421	BOTTLERK	1	36
31404	WEST FOR	2	36
31402	BEAR CAN	1	36
31402	BEAR CAN	2	36
31404	WEST FOR	1	36
31414	GEYSER12	1	36
31418	GEYSER14	1	36
31420	GEYSER16	1	36

Attachment B – Effectiveness factors for procurement guidance

Gen Bus	Gen Name	Gen ID	Eff Factor (%)
31422	GEYSER17	1	36
38110	NCPA2GY1	1	36
38112	NCPA2GY2	1	36
31446	SONMA LF	1	36
32700	MONTICLO	1	31
32700	MONTICLO	2	31
32700	MONTICLO	3	31
31406	GEYSR5-6	1	18
31406	GEYSR5-6	2	18
31405	RPSP1014	1	18
31408	GEYSER78	1	18
31408	GEYSER78	2	18
31412	GEYSER11	1	18
31435	GEO.ENGY	1	18
31435	GEO.ENGY	2	18
31433	POTTRVLY	1	15
31433	POTTRVLY	2	15
31433	POTTRVLY	3	15
38020	CITY UKH	1	15
38020	CITY UKH	2	15

Table – Rio Oso

Effectiveness factors to the Rio Oso-Atlantic 230 kV line:

Gen Bus	Gen Name	Gen ID	Eff Factor. (%)
32498	SPILINCF	1	49
32500	ULTR RCK	1	49
32456	MIDLFORK	1	33
32456	MIDLFORK	2	33
32458	RALSTON	1	33

Attachment B – Effectiveness factors for procurement guidance

32513	ELDRADO1	1	32
32514	ELDRADO2	1	32
32510	CHILIBAR	1	32
32486	HELLHOLE	1	31
32508	FRNCH MD	1	30
32460	NEWCASTLE	1	26
32478	HALSEY F	1	24
32512	WISE	1	24
38114	Stig CC	1	14
38123	Q267CT	1	14
38124	Q267ST	1	14
32462	CHI.PARK	1	8
32464	DTCHFLT1	1	4

Table – South of Table Mountain

Effectiveness factors to the Caribou-Palermo 115 kV line:

Gen Bus	Gen Name	Gen ID	Eff Factor. (%)
31814	FORBSTWN	1	7
31794	WOODLEAF	1	7
31832	SLY.CR.	1	7
31862	DEADWOOD	1	7
31890	PO POWER	1	6
31890	PO POWER	2	6
31888	OROVILLE	1	6
31834	KELLYRDG	1	6
32450	COLGATE1	1	4

Attachment B – Effectiveness factors for procurement guidance

Gen Bus	Gen Name	Gen ID	Eff Factor. (%)
32466	NARROWS1	1	4
32468	NARROWS2	1	4
32452	COLGATE2	1	4
32470	CMP.FARW	1	4
32451	FREC	1	4
32490	GRNLEAF1	1	4
32490	GRNLEAF1	2	4
32496	YCEC	1	4
32494	YUBA CTY	1	4
32492	GRNLEAF2	1	4
32498	SPILINCF	1	2
31788	ROCK CK2	1	2
31812	CRESTA	1	2
31812	CRESTA	2	2
31820	BCKS CRK	1	2
31820	BCKS CRK	2	2
31786	ROCK CK1	1	2
31790	POE 1	1	2
31792	POE 2	1	2
31784	BELDEN	1	2
32500	ULTR RCK	1	2
32156	WOODLAND	1	2
32510	CHILIBAR	1	2
32513	ELDRADO1	1	2
32514	ELDRADO2	1	2
32478	HALSEY F	1	2
32460	NEWCASTLE	1	1

Attachment B – Effectiveness factors for procurement guidance

Gen Bus	Gen Name	Gen ID	Eff Factor. (%)
32458	RALSTON	1	1
32512	WISE	1	1
32456	MIDLFORK	1	1
32456	MIDLFORK	2	1
32486	HELLHOLE	1	1
32508	FRNCH MD	1	1
32162	RIV.DLTA	1	1
32502	DTCHFLT2	1	1
32462	CHI.PARK	1	1
32464	DTCHFLT1	1	1
32454	DRUM 5	1	1
32476	ROLLINSF	1	1
32484	OXBOW F	1	1
32474	DEER CRK	1	1
32504	DRUM 1-2	1	1
32504	DRUM 1-2	2	1
32506	DRUM 3-4	1	1
32506	DRUM 3-4	2	1
32166	UC DAVIS	1	1
32472	SPAULDG	1	1
32472	SPAULDG	2	1
32472	SPAULDG	3	1
32480	BOWMAN	1	1
32488	HAYPRES+	1	1
32488	HAYPRES+	2	1
38124	LODI ST1	1	1
38123	LODI CT1	1	1

Attachment B – Effectiveness factors for procurement guidance

Gen Bus	Gen Name	Gen ID	Eff Factor. (%)
38114	STIG CC	1	1

Table – San Jose

Effectiveness factors to the El Patio-San Jose 'A' 115 kV line:

Gen Bus	Gen Name	Gen ID	Eff Factor (%)
35863	CATALYST	1	36
36863	DVRaGT1	1	13
36864	DVRbGt2	1	13
36865	DVRaST3	1	13
36859	Laf300	2	13
36859	Laf300	1	13
36856	CCA100	1	13
36858	Gia100	1	12
36895	Gia200	1	12
35861	SJ-SCL W	1	9
35854	LECEFGT1	1	9
35855	LECEFGT2	1	9
35856	LECEFGT3	1	9
35857	LECEFGT4	1	9
35858	LECEFST1	1	9
35860	OLS-AGNE	1	9

Table – South Bay-Moss Landing

Effectiveness factors to the Moss Landing-Las Aguillas 230 kV line:

Gen Bus	Gen Name	Gen ID	Eff Factor. (%)
36209	SLD ENRG	1	20
36221	DUKMOSS1	1	20
36222	DUKMOSS2	1	20

Attachment B – Effectiveness factors for procurement guidance

36223	DUKMOSS3	1	20
36224	DUKMOSS4	1	20
36225	DUKMOSS5	1	20
36226	DUKMOSS6	1	20
36405	MOSSLND6	1	17
36406	MOSSLND7	1	17
35881	MEC CTG1	1	13
35882	MEC CTG2	1	13
35883	MEC STG1	1	13
35850	GLRY COG	1	12
35850	GLRY COG	2	12
35851	GROYPKR1	1	12
35852	GROYPKR2	1	12
35853	GROYPKR3	1	12
35623	SWIFT	BT	10
35863	CATALYST	1	10
36863	DVRaGT1	1	8
36864	DVRbGt2	1	8
36865	DVRaST3	1	8
36859	Laf300	2	8
36859	Laf300	1	8
36858	Gia100	1	7
36895	Gia200	1	7
35854	LECEFGT1	1	7
35855	LECEFGT2	1	7

Attachment B – Effectiveness factors for procurement guidance

35856	LECEFGT3	1	7
35857	LECEFGT4	1	7
35858	LECEFST1	1	7
35860	OLS-AGNE	1	7

Table – Ames/Pittsburg/Oakland

Effectiveness factors to the Ames-Ravenswood #1 115 kV line:

Gen Bus	Gen Name	Gen ID	Eff Factor. (%)
35304	RUSELCT1	1	10
35305	RUSELCT2	2	10
35306	RUSELST1	3	10
33469	OX_MTN	1	10
33469	OX_MTN	2	10
33469	OX_MTN	3	10
33469	OX_MTN	4	10
33469	OX_MTN	5	10
33469	OX_MTN	6	10
33469	OX_MTN	7	10
33107	DEC STG1	1	3
33108	DEC CTG1	1	3
33109	DEC CTG2	1	3
33110	DEC CTG3	1	3
33102	COLUMBIA	1	3
33111	LMECCT2	1	3
33112	LMECCT1	1	3

Attachment B – Effectiveness factors for procurement guidance

33113	LMECST1	1	3
33151	FOSTER W	1	2
33151	FOSTER W	2	2
33151	FOSTER W	3	2
33136	CCCSD	1	2
33141	SHELL 1	1	2
33142	SHELL 2	1	2
33143	SHELL 3	1	2
32900	CRCKTCOG	1	2
32910	UNOCAL	1	2
32910	UNOCAL	2	2
32910	UNOCAL	3	2
32920	UNION CH	1	2
32921	ChevGen1	1	2
32922	ChevGen2	1	2
32923	ChevGen3	3	2
32741	HILLSIDE_12	1	2
32901	OAKLND 1	1	1
32902	OAKLND 2	2	1
32903	OAKLND 3	3	1
38118	ALMDACT1	1	1
38119	ALMDACT2	1	1

Effectiveness factors to the Moraga-Clairemont #2 115 kV line:

Gen Bus	Gen Name	Gen ID	Eff Factor. (%)
---------	----------	--------	-----------------

Attachment B – Effectiveness factors for procurement guidance

32741	HILLSIDE_12	1	15
32921	ChevGen1	1	15
32922	ChevGen2	1	15
32923	ChevGen3	3	15
32920	UNION CH	1	14
32910	UNOCAL	1	13
32910	UNOCAL	2	13
32910	UNOCAL	3	13
32901	OAKLND 1	1	10
32902	OAKLND 2	2	10
32903	OAKLND 3	3	10
38118	ALMDACT1	1	10
38119	ALMDACT2	1	10
33141	SHELL 1	1	9
33142	SHELL 2	1	9
33143	SHELL 3	1	9
33136	CCCSD	1	8
32900	CRCKTCOG	1	7
33151	FOSTER W	1	6
33151	FOSTER W	2	6
33151	FOSTER W	3	6
33102	COLUMBIA	1	3
33111	LMECCT2	1	3
33112	LMECCT1	1	3
33113	LMECST1	1	3

Attachment B – Effectiveness factors for procurement guidance

33107	DEC STG1	1	3
33108	DEC CTG1	1	3
33109	DEC CTG2	1	3
33110	DEC CTG3	1	3

Table – Herndon

Effectiveness factors to the Herndon-Manchester 115 kV line:

Gen Bus	Gen Name	Gen ID	Eff Factor. (%)
34624	BALCH 1	1	22
34616	KINGSRIV	1	21
34648	DINUBA E	1	20
34671	KRCDPCT1	1	19
34672	KRCDPCT2	1	19
34308	KERCKHOF	1	18
34344	KERCK1-1	1	18
34345	KERCK1-3	3	18
34677	Q558	1	15
34690	CORCORAN_3	FW	15
34692	CORCORAN_4	FW	15
34696	CORCORANPV_S	1	15
34610	HAAS	1	13
34610	HAAS	2	13
34612	BLCH 2-2	1	13
34614	BLCH 2-3	1	13
34431	GWF_HEP1	1	8

Attachment B – Effectiveness factors for procurement guidance

34433	GWF_HEP2	1	8
34617	Q581	1	5
34680	KANSAS	1	5
34467	GIFFEN_DIST	1	4
34563	STROUD_DIST	2	4
34563	STROUD_DIST	1	4
34608	AGRICO	2	4
34608	AGRICO	3	4
34608	AGRICO	4	4
34644	Q679	1	4
365502	Q632BC1	1	4

Table – LA Basin

Effectiveness factors to the Mesa – Laguna Bell #1 230 kV line:

Gen Bus	Gen Name	Gen ID	Eff Factor. (%)
29951	REFUSE	D1	35
24239	MALBRG1G	C1	34
24240	MALBRG1G	C2	34
24241	MALBRG1G	S3	34
29903	ELSEG6ST	6	27
29904	ELSEG5GT	5	27
29902	ELSEG7ST	7	27
29901	ELSEG8GT	8	27
24337	VENICE	1	26
24094	MOBGEN1	1	26

Attachment B – Effectiveness factors for procurement guidance

24329	MOBGEN2	1	26
24332	PALOGEN	D1	26
24011	ARCO 1G	1	23
24012	ARCO 2G	2	23
24013	ARCO 3G	3	23
24014	ARCO 4G	4	23
24163	ARCO 5G	5	23
24164	ARCO 6G	6	23
24062	HARBOR G	1	23
24062	HARBOR G	HP	23
25510	HARBORG4	LP	23
24327	THUMSGEN	1	23
24020	CARBGEN1	1	23
24328	CARBGEN2	1	23
24139	SERRFGEN	D1	23
24070	ICEGEN	1	22
24001	ALAMT1 G	1	18
24002	ALAMT2 G	2	18
24003	ALAMT3 G	3	18
24004	ALAMT4 G	4	18
24005	ALAMT5 G	5	18
24161	ALAMT6 G	6	18
90000	ALMT-GT1	X1	18
90001	ALMT-GT2	X2	18
90002	ALMT-ST1	X3	18

Attachment B – Effectiveness factors for procurement guidance

29308	CTRPKGEN	1	18
29953	SIGGEN	D1	18
29309	BARPKGEN	1	13
29201	WALCRKG1	1	12
29202	WALCRKG2	1	12
29203	WALCRKG3	1	12
29204	WALCRKG4	1	12
29205	WALCRKG5	1	12
29011	BREAPWR2	C1	12
29011	BREAPWR2	C2	12
29011	BREAPWR2	C3	12
29011	BREAPWR2	C4	12
29011	BREAPWR2	S1	12
24325	ORCOGEN	I	12
24341	COYGEN	I	11
25192	WDT1406_G	I	11
25208	DowlingCTG	1	10
25211	CanyonGT 1	1	10
25212	CanyonGT 2	2	10
25213	CanyonGT 3	3	10
25214	CanyonGT 4	4	10
24216	VILLA PK	DG	9

Table – Rector

Effectiveness factors to the Rector-Vestal 230 kV line:

Attachment B – Effectiveness factors for procurement guidance

Gen Bus	Gen Name	Gen ID	MW Eff Factor (%)
24370	KAWGEN	1	51
24306	B CRK1-1	1	45
24306	B CRK1-1	2	45
24307	B CRK1-2	3	45
24307	B CRK1-2	4	45
24319	EASTWOOD	1	45
24323	PORTAL	1	45
24308	B CRK2-1	1	45
24308	B CRK2-1	2	45
24309	B CRK2-2	3	45
24309	B CRK2-2	4	45
24310	B CRK2-3	5	45
24310	B CRK2-3	6	45
24315	B CRK 8	81	45
24315	B CRK 8	82	45
24311	B CRK3-1	1	45
24311	B CRK3-1	2	45
24312	B CRK3-2	3	45
24312	B CRK3-2	4	45
24313	B CRK3-3	5	45
24317	MAMOTH1G	1	45
24318	MAMOTH2G	2	45
24314	B CRK 4	41	43
24314	B CRK 4	42	43

Table – San Diego

Effectiveness factors to the Imperial Valley – El Centro 230 kV line (i.e., the “S” line):

Attachment B – Effectiveness factors for procurement guidance

Gen Bus	Gen Name	Gen ID	Eff Factor. (%)
22982	TDM CTG2	1	25
22983	TDM CTG3	1	25
22981	TDM STG	1	25
22997	INTBCT	1	25
22996	INTBST	1	25
23440	DW GEN2 G1	1	25
23298	DW GEN1 G1	G1	25
23156	DU GEN1 G2	G2	25
23299	DW GEN1 G2	G2	25
23155	DU GEN1 G1	G1	25
23441	DW GEN2 G2	1	25
23442	DW GEN2 G3A	1	25
23443	DW GEN2 G3B	1	25
23314	OCO GEN G1	G1	23
23318	OCO GEN G2	G2	23
23100	ECO GEN1 G	G1	22
23352	ECO GEN2 G	1	21
22605	OTAYMGT1	1	18
22606	OTAYMGT2	1	18
22607	OTAYMST1	1	18
23162	PIO PICO CT1	1	18
23163	PIO PICO CT2	1	18
23164	PIO PICO CT3	1	18
22915	KUMEYAAY	1	17

Attachment B – Effectiveness factors for procurement guidance

23320	EC GEN2	1	17
22150	EC GEN1	1	17
22617	OY GEN	1	17
22604	OTAY	1	17
22604	OTAY	3	17
22172	DIVISION	1	17
22576	NOISLMTR	1	17
22704	SAMPSON	1	17
22092	CABRILLO	1	17
22074	LRKSPBD1	1	17
22075	LRKSPBD2	1	17
22660	POINTLMA	1	17
22660	POINTLMA	2	17
22149	CALPK_BD	1	17
22448	MESAHGTS	1	16
22120	CARLTNHS	1	16
22120	CARLTNHS	2	16
22496	MISSION	1	16
22486	MEF MR1	1	16
22124	CHCARITA	1	16
22487	MEF MR2	1	16
22625	LkHodG1	1	16
22626	LkHodG2	2	16
22332	GOALLINE	1	15
22262	PEN_CT1	1	15

Attachment B – Effectiveness factors for procurement guidance

22153	CALPK_ES	1	15
22786	EA GEN1 U6	1	15
22787	EA GEN1 U7	1	15
22783	EA GEN1 U8	1	15
22784	EA GEN1 U9	1	15
22789	EA GEN1 U10	1	15
22257	ES GEN	1	15
22263	PEN_CT2	1	15
22265	PEN_ST	1	15
22724	SANMRCOS	1	15
22628	PA GEN1	1	14
22629	PA GEN2	1	14
22082	BR GEN1	1	14
22112	CAPSTRNO	1	12