

2025 LOCAL CAPACITY TECHNICAL STUDY

DRAFT REPORT AND STUDY RESULTS

Intentionally left blank

Executive Summary

This Report documents the results and recommendations of the 2025 Long-Term Local Capacity Technical (LCT) Study. The LCT Study assumptions, processes, and criteria were discussed and recommended through the 2021 Local Capacity Technical Study Criteria, Methodology and Assumptions Stakeholder Meeting held on October 31, 2019. On balance, the assumptions, processes, and criteria used for the 2025 Long-Term LCT Study mirror those used in the 2007-2020 LCT Studies, which were previously discussed and recommended through the LCT Study Advisory Group (“LSAG”)¹, an advisory group formed by the CAISO to assist the CAISO in its preparation for performing prior LCT Studies.

The load forecast used in this study is based on the final adopted California Energy Demand 2020-2030 Revised Forecast, developed by the CEC; namely the load-serving entity (LSE) and balancing authority (BA) mid baseline demand with low additional achievable energy efficiency and photo voltaic (AAEE-AAPV), posted on 3/4/2020: <https://efiling.energy.ca.gov/GetDocument.aspx?tn=232305&DocumentContentId=64305>.

To aide procurement, this LCT study provides load profiles and transmission capacity information that shows the effectiveness of local resources in meeting temporal local reliability needs.

Overall, the capacity needed for LCR has increased by about 153 MW or about 0.7% from 2024 to 2025.

The LCR needs have decreased in the following areas: Stockton due to new transmission projects and changes to the LCR criteria, Big Creek/Ventura and San Diego due to load forecast decrease and new transmission projects, Humboldt requirement is the same.

The LCR needs have increased in the following areas: North Coast/North Bay and Fresno due to change in the LCR criteria, Bay Area, Sierra and Kern due to load forecast increase and changes to the LCR criteria, LA Basin due to CEC and SCE reallocation of substation loads resulting in a higher amount in Western LA Basin..

The narrative for each Local Capacity Area lists important new projects included in the base cases as well as a description of reason for changes between the 2024 and 2025 LCT study results.

The 2024 and 2025 total LCR needs are provided below for comparison:

¹ The LSAG consists of a representative cross-section of stakeholders, technically qualified to assess the issues related to the study assumptions, process and criteria of the existing LCT Study methodology and to recommend changes, where needed.

2025 Local Capacity Needs

Local Area Name	Qualifying Capacity				Capacity Available at Peak	2025 LCR Need Category C
	QF/ Muni (MW)	Non-Solar (MW)	Solar (MW)	Total (MW)	Total (MW)	Capacity Needed
Humboldt	0	191	0	191	191	132
North Coast/ North Bay	119	723	0	842	842	837
Sierra	1183	920	5	2108	2103	1367*
Stockton	116	491	12	619	607	619*
Greater Bay	604	6732	8	7344	7344	6110*
Greater Fresno	216	2815	361	3392	3191	1971*
Kern	5	330	78	413	335	186*
Big Creek/ Ventura	424	2963	250	3637	3637	1002
LA Basin	1197	6215	11	7423	7423	6309
San Diego/ Imperial Valley	2	4438	378	4818	4440	3557
Total	3866	25818	1103	30787	30113	22090

2024 Local Capacity Needs

Local Area Name	Qualifying Capacity				Capacity Available at Peak	2024 LCR Need Category B	2024 LCR Need Category C
	QF/ Muni (MW)	Non-Solar (MW)	Solar (MW)	Total (MW)	Total (MW)	Capacity Needed	Capacity Needed
Humboldt	0	197	0	197	197	83	132
North Coast/ North Bay	117	715	1	833	832	706	706
Sierra	1168	986	6	2160	2154	788	1304
Stockton	137	680	1	699	698	388*	675*
Greater Bay	617	7011	12	7640	7640	3494	4395
Greater Fresno	203	2733	393	3329	2901	1711	1711*
Kern	8	354	103	465	362	0	152*
Big Creek/ Ventura	402	2774	305	3481	3481	2083*	2577*
LA Basin	1344	7038	17	8399	8399	6224	6260
San Diego/ Imperial Valley	4	4032	523	4559	4036	4025	4025
Total	4000	26520	1361	31762	30700	19502	21937

* No local area is “overall deficient”. Details about magnitude of deficiencies can be found in the applicable section below. Resource deficient sub-area implies that in order to comply with the criteria, at summer peak, load may be shed immediately after the first contingency.

** Since “deficiency” cannot be mitigated by any available resource, the “Existing Capacity Needed” will be split among LSEs on a load share ratio during the assignment of local area resource responsibility.

Intentionally left blank

Table of Contents

Executive Summary	1
1 Overview of the Study: Inputs, Outputs and Options.....	6
1.1 Objectives	6
1.2 Key Study Assumptions	6
1.2.1 Inputs, Assumptions and Methodology	6
1.3 Grid Reliability	8
1.4 Application of N-1, N-1-1, and N-2 Criteria	8
1.5 Performance Criteria	9
1.5.1 Performance Criteria	9
1.5.2 CAISO Statutory Obligation Regarding Safe Operation	10
2 Assumption Details: How the Study was Conducted.....	14
2.1 System Planning Criteria.....	14
2.1.1 Power Flow Assessment:	17
2.1.2 Post Transient Load Flow Assessment:.....	18
2.1.3 Stability Assessment:	18
2.2 Load Forecast	18
2.2.1 System Forecast	18
2.2.2 Base Case Load Development Method	18
2.3 Power Flow Program Used in the LCR analysis	20
3 Locational Capacity Requirement Study Results	21
3.1 Summary of Study Results	21
3.2 Summary of Results by Local Area	23
3.2.1 Humboldt Area	23
3.2.2 North Coast / North Bay Area	26
3.2.3 Sierra Area	38
3.2.4 Stockton Area.....	48
3.2.5 Greater Bay Area	55
3.2.6 Greater Fresno Area	73
3.2.7 Kern Area	97
3.2.8 Big Creek/Ventura Area.....	109
3.2.9 LA Basin Area	119
3.2.10 San Diego-Imperial Valley Area.....	129
3.2.11 Valley Electric Area	140
Attachment A – List of physical resources by PTO, local area and market ID	141
Attachment B – Effectiveness factors for procurement guidance.....	185

Intentionally left blank

1 Overview of the Study: Inputs, Outputs and Options

1.1 Objectives

The intent of the 2025 Long-Term LCT Study is to identify specific areas within the CAISO Balancing Authority Area that have limited import capability and determine the minimum generation capacity (MW) necessary to mitigate the local reliability problems in those areas, as was the objective of all previous Local Capacity Technical Studies.

To aide procurement, this LCT study provides load profiles and transmission capacity information that shows the effectiveness of local resources in meeting temporal local reliability needs.

1.2 Key Study Assumptions

1.2.1 Inputs, Assumptions and Methodology

The inputs, assumptions and methodology were discussed and agreed to by stakeholders at the 2021 LCT Study Criteria, Methodology and Assumptions Stakeholder Meeting held on October 31, 2019. They are similar to those used and incorporated in previous LCT studies. The following table sets forth a summary of the approved inputs and methodology that have been used in this 2025 Long-Term LCT Study:

Table 1.2-1 Summary Table of Inputs and Methodology Used in this LCT Study:

Issue	How Incorporated into this LCT Study:
Input Assumptions:	
Transmission System Configuration	The existing transmission system has been modeled, including all projects operational on or before June 1, of the study year and all other feasible operational solutions brought forth by the PTOs and as agreed to by the CAISO.
Generation Modeled	The existing generation resources has been modeled and also includes all projects that will be on-line and commercial on or before June 1, of the study year
Load Forecast	Uses a 1-in-10 year summer peak load forecast
Methodology:	

Maximize Import Capability	Import capability into the load pocket has been maximized, thus minimizing the generation required in the load pocket to meet applicable reliability requirements.
QF/Nuclear/State/Federal Units	Regulatory Must-take and similarly situated units like QF/Nuclear/State/Federal resources have been modeled on-line at qualifying capacity output values for purposes of this LCT Study.
Maintaining Path Flows	Path flows have been maintained below all established path ratings into the load pockets, including the 500 kV. For clarification, given the existing transmission system configuration, the only 500 kV path that flows directly into a load pocket and will, therefore, be considered in this LCT Study is the South of Lugo transfer path flowing into the LA Basin.
Performance Criteria:	
All Performance Levels, including incorporation of PTO operational solutions	This LCT Study is being published based on the most stringent of all mandatory reliability standards. In addition, the CAISO will incorporate all new projects and other feasible and CAISO-approved operational solutions brought forth by the PTOs that can be operational on or before June 1, of the study year. Any such solutions that can reduce the need for procurement to meet the mandatory standards will be incorporated into the LCT Study.
Load Pocket:	
Fixed Boundary, including limited reference to published effectiveness factors	This LCT Study has been produced based on load pockets defined by a fixed boundary. The CAISO only publishes effectiveness factors where they are useful in facilitating procurement where excess capacity exists within a load pocket.

Further details regarding the 2025 Long-Term LCT Study methodology and assumptions are provided in Section III, below.

1.3 Grid Reliability

Service reliability builds from grid reliability because grid reliability is reflected in the Reliability Standards of the North American Electric Reliability Council (NERC) and the Western Electricity Coordinating Council (“WECC”) Regional Criteria (collectively “Reliability Standards”). The Reliability Standards apply to the interconnected electric system in the United States and are intended to address the reality that within an integrated network, whatever one Balancing Authority Area does can affect the reliability of other Balancing Authority Areas. Consistent with the mandatory nature of the Reliability Standards, the CAISO is under a statutory obligation to ensure efficient use and reliable operation of the transmission grid consistent with achievement of the Reliability Standards.² The CAISO is further under an obligation, pursuant to its FERC-approved Transmission Control Agreement, to secure compliance with all “Applicable Reliability Criteria.” Applicable Reliability Criteria consists of the Reliability Standards as well as reliability criteria adopted by the CAISO (Grid Planning Standards).

The Reliability Standards define reliability on interconnected electric systems using the terms “adequacy” and “security.” “Adequacy” is the ability of the electric systems to supply the aggregate electrical demand and energy requirements of their customers at all times, taking into account physical characteristics of the transmission system such as transmission ratings and scheduled and reasonably expected unscheduled outages of system elements. “Security” is the ability of the electric systems to withstand sudden disturbances such as electric short circuits or unanticipated loss of system elements. The Reliability Standards are organized by Performance Categories. Certain categories require that the grid operator not only ensure that grid integrity is maintained under certain adverse system conditions (e.g., security), but also that all customers continue to receive electric supply to meet demand (e.g., adequacy). In that case, grid reliability and service reliability would overlap. But there are other levels of performance where security can be maintained without ensuring adequacy.

1.4 Application of N-1, N-1-1, and N-2 Criteria

The CAISO will maintain the system in a safe operating mode at all times. This obligation translates into respecting the Reliability Criteria at all times, for example during normal operating conditions (N-0) the CAISO must protect for all single contingencies (N-1) and common mode (N-2) double line outages. Also, after a single contingency, the CAISO must re-adjust the system to support the loss of the next most stringent contingency. This is referred to as the N-1-1 condition.

The N-1-1 vs N-2 terminology was introduced only as a temporal differentiation between two existing NERC Category P6 and P7 events. N-1-1 represents NERC Category C6 (“category P1 contingency, manual system adjustment, followed by another category P1 contingency”). The N-2 represents NERC Category P7 (“any two circuits of a multiple circuit tower line”) as well as WECC-S2 (for 500 kV only) (“any two circuits in the same right-of-way”) with no manual system adjustment between the two contingencies.

² Pub. Utilities Code § 345

1.5 Performance Criteria

As set forth on the Summary Table of Inputs and Methodology, this LCR Report is based on the most stringent mandatory standard (NERC, WECC or CAISO). The CAISO tests the electric system in regards to thermal overloads as well as dynamic and reactive margin compliance with the existing standards.

1.5.1 Performance Criteria

Category P0, P1 & P3 system performance requires that all thermal and voltage limits must be within their “Applicable Rating,” which, in this case, are the emergency ratings as generally determined by the PTO or facility owner. Applicable Rating includes a temporal element such that emergency ratings can only be maintained for certain duration. Under this category, load cannot be shed in order to assure the Applicable Ratings are met however there is no guarantee that facilities are returned to within normal ratings or to a state where it is safe to continue to operate the system in a reliable manner such that the next element out will not cause a violation of the Applicable Ratings.

The NERC Planning Standards require system operators to “look forward” to make sure they safely prepare for the “next” N-1 following the loss of the “first” N-1 (stay within Applicable Ratings after the “next” N-1). This is commonly referred to as N-1-1. Because it is assumed that some time exists between the “first” and “next” element losses, operating personnel may make any reasonable and feasible adjustments to the system to prepare for the loss of the second element, including, operating procedures, dispatching generation, moving load from one substation to another to reduce equipment loading, dispatching operating personnel to specific station locations to manually adjust load from the substation site, or installing a “Special Protection Scheme” that would remove pre-identified load from service upon the loss of the “next “ element.³ All Category P2, P4, P5, P6, P7 and extreme event requirements in this report refer to situations when in real time (N-0) or after the first contingency (N-1) the system requires additional readjustment in order to prepare for the next worst contingency. In this time frame, load drop is not allowed per existing planning criteria.

Generally, Category P2, P4, P5, P6, P7 and extreme event describes system performance that is expected following the loss of two or more system elements. This loss of two elements is generally expected to happen simultaneously, referred to as N-2. It should be noted that once the “next” element is lost after the first contingency, as discussed above under the Performance Criteria P1, the event is effectively a Category P6 or N-1-1 scenario. As noted above, depending on system design and expected system impacts, the **planned and controlled** interruption of

³ A Special Protection Scheme is typically proposed as an operational solution that does not require additional generation and permits operators to effectively prepare for the next event as well as ensure security should the next event occur. However, these systems have their own risks, which limit the extent to which they could be deployed as a solution for grid reliability augmentation. While they provide the value of protecting against the next event without the need for pre-contingency load shedding, they add points of potential failure to the transmission network. This increases the potential for load interruptions because sometimes these systems will operate when not required and other times they will not operate when needed.

supply to customers (load shedding), the removal from service of certain generators and curtailment of exports may be utilized to maintain grid “security.”

1.5.2 CAISO Statutory Obligation Regarding Safe Operation

The ISO must maintain the system in a safe operating mode at all times. This obligation translates into respecting the Reliability Criteria at all times. For example, during normal operating conditions (8760 hours per year), the ISO must protect for all single contingencies (P1, P2) and multiple contingencies (P4, P5) as well as common mode double line outages (P7). As a further example, after a single contingency, the ISO must readjust the system in order to be able to support the loss of the next most stringent contingency (P3, P6 and P1+P7 resulting in potential voltage collapse or dynamic instability).

Figure 1.5-1 Temporal graph of LCR Category P0-P7

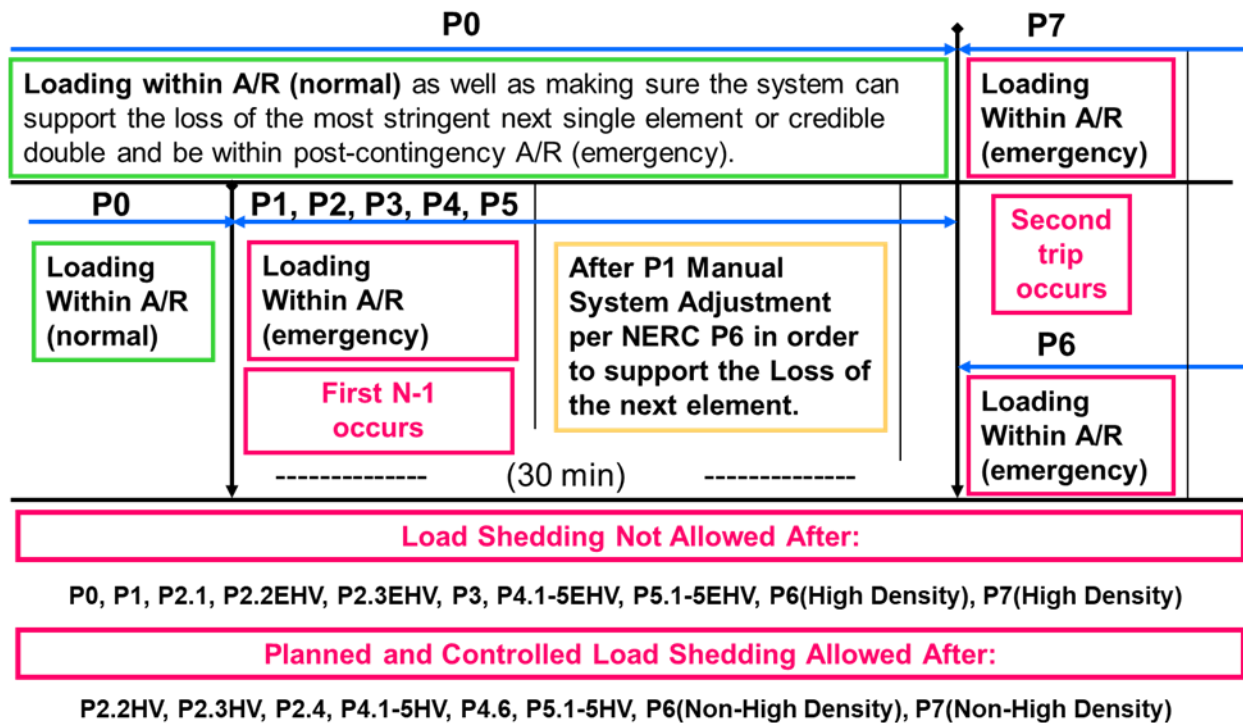

The following definitions guide the CAISO’s interpretation of the Reliability Criteria governing safe mode operation and are used in this LCT Study:

Applicable Rating:

This represents the equipment rating that will be used under certain contingency conditions.

Normal rating is to be used under normal conditions.

Long-term emergency ratings, if available, will be used in all emergency conditions as long as “system readjustment” is provided in the amount of time given (specific to each element) to reduce the flow to within the normal ratings. If not available, the normal rating is to be used.

Short-term emergency ratings, if available, can be used as long as “system readjustment” is provided in the “short-time” available in order to reduce the flow to within the long-term emergency ratings where the element can be kept for another length of time (specific to each element) before the flow needs to be reduced the below the normal ratings. If not available long-term emergency rating should be used.

Temperature-adjusted ratings shall not be used because this is a year-ahead study, not a real-time tool, and as such the worst-case scenario must be covered. In case temperature-adjusted ratings are the only ratings available then the minimum rating (highest temperature) given the study conditions shall be used.

CAISO Transmission Register is the only official keeper of all existing ratings mentioned above.

Ratings for future projects provided by PTO and agreed upon by the CAISO shall be used.

Other short-term ratings not included in the CAISO Transmission Register may be used as long as they are engineered, studied and enforced through clear operating procedures that can be followed by real-time operators.

Path Ratings need to be maintained within their limits in order to assure that proper capacity is available in order to operate the system in real-time in a safe operating zone.

Controlled load drop:

This is achieved with the use of a Special Protection Scheme.

Planned load drop:

This is achieved when the most limiting equipment has short-term emergency ratings AND the operators have an operating procedure that clearly describes the actions that need to be taken in order to shed load.

Special Protection Scheme:

All known SPS shall be assumed. New SPS must be verified and approved by the CAISO and must comply with the new SPS guideline described in the CAISO Planning Standards.

System Readjustment:

This represents the actions taken by operators in order to bring the system within a safe operating zone after any given contingency in the system.

Actions that can be taken as system readjustment after a Category P1, P2.1, P2.2(EHV), P2.3(EHV), P3, P4.1-5(EHV), P5.1-5(EHV), P6(high density area)&P7(high density area) contingency:

1. System configuration change – based on validated and approved operating procedures
2. Generation re-dispatch

- a. Decrease generation (up to 1150 MW) – limit given by single contingency SPS as part of the ISO Grid Planning standards (ISO SPS3)
- b. Increase generation – this generation will become part of the LCR need

Actions, which shall not be taken as system readjustment after a Category P1, P2.1, P2.2(EHV), P2.3(EHV), P3, P4.1-5(EHV), P5.1-5(EHV), P6(high density area)&P7(high density area) contingency:

1. Load drop – based on the intent of the ISO/WECC and NERC criteria for category P1 contingencies.

An objective of the planning process is to minimize the likelihood and magnitude of Non-Consequential Load Loss following Contingency events. NERC and ISO Planning standards mandate that no load shedding should be done immediately after a Category P1, P2.1, P2.2(EHV), P2.3(EHV), P3, P4.1-5(EHV), P5.1-5(EHV), P6(high density area)&P7(high density area) contingency. The system should be planned with no load shedding regardless of when it may occur (immediately or within 15-30 minutes after the first contingency). It follows that load shedding may not be utilized as part of the system readjustment period – in order to protect for the next most limiting contingency. Therefore, if there are available resources in the local area, such resources should be used during the manual adjustment period (and included in the LCR need) before resorting to shedding firm load.

Firm load shedding is allowed in a planned and controlled manner after the first contingency in P2.2(HV), P2.3(HV), P2.4, P4.1-5(HV), P4.6, P5.1-5(HV) and after the second contingency in P6(non-high density area), P7(non-high density area) & P1 system adjusted followed by P7 category events.

This interpretation tends to guarantee that firm load shedding is used to address Category P1, P2.1, P2.2(EHV), P2.3(EHV), P3, P4.1-5(EHV), P5.1-5(EHV), P6(high density area)&P7(high density area) conditions only under the limited circumstances where no other resource or validated operational measure is available. A contrary interpretation would constitute a departure from existing practice and degrade current service expectations by increasing load's exposure to service interruptions.

Time allowed for manual readjustment:

Tariff Section 40.3.1.1, requires the CAISO, in performing the Local Capacity Technical Study, to apply the following reliability criterion:

Time Allowed for Manual Adjustment: This is the amount of time required for the Operator to take all actions necessary to prepare the system for the next Contingency. The time should not be more than thirty (30) minutes.

The CAISO Planning Standards also impose this manual readjustment requirement. As a parameter of the Local Capacity Technical Study, the CAISO must assume that as the system operator the CAISO will have sufficient time to:

- (1) make an informed assessment of system conditions after a contingency has occurred;
- (2) identify available resources and make prudent decisions about the most effective system redispatch;
- (3) manually readjust the system within safe operating limits after a first contingency to be prepared for the next contingency; and
- (4) allow sufficient time for resources to ramp and respond according to the operator's redispatch instructions. This all must be accomplished within 30 minutes.

Local capacity resources can meet this requirement by either (1) responding with sufficient speed, allowing the operator the necessary time to assess and redispatch resources to effectively reposition the system within 30 minutes after the first contingency, or (2) have sufficient energy available for frequent dispatch on a pre-contingency basis to ensure the operator can meet minimum online commitment constraints or reposition the system within 30 minutes after the first contingency occurs. Accordingly, when evaluating resources that satisfy the requirements of the CAISO Local Capacity Technical Study, the CAISO assumes that local capacity resources need to be available in no longer than 20 minutes so the CAISO and demand response providers have a reasonable opportunity to perform their respective and necessary tasks and enable the CAISO to reposition the system within the 30 minutes in accordance with applicable reliability criteria.

2 Assumption Details: How the Study was Conducted

2.1 System Planning Criteria

The following table provides a comparison of system planning criteria, based on the NERC performance standards, used in the study:

Table 2.1-1: Criteria Comparison for Bulk Electric System contingencies

Contingency Component(s)	Mandatory Reliability Standards	Old Local Capacity Criteria	New Local Capacity Criteria
<u>P0 – No Contingencies</u>	X	X	X
<u>P1 – Single Contingency</u>			
1. Generator (G-1)	X	X ¹	X ¹
2. Transmission Circuit (L-1)	X	X ¹	X ¹
3. Transformer (T-1)	X	X ^{1,2}	X ¹
4. Shunt Device	X		X ¹
5. Single Pole (dc) Line	X	X ¹	X ¹
<u>P2 – Single contingency</u>			
1. Opening a line section w/o a fault	X		X
2. Bus Section fault	X		X
3. Internal Breaker fault (non-Bus-tie Breaker)	X		X
4. Internal Breaker fault (Bus-tie Breaker)	X		X
<u>P3 – Multiple Contingency – G-1 + system adjustment and:</u>			
1. Generator (G-1)	X	X	X
2. Transmission Circuit (L-1)	X	X	X
3. Transformer (T-1)	X	X ²	X
4. Shunt Device	X		X
5. Single Pole (dc) Line	X	X	X
<u>P4 – Multiple Contingency - Fault plus stuck breaker</u>			
1. Generator (G-1)	X		X
2. Transmission Circuit (L-1)	X		X
3. Transformer (T-1)	X		X
4. Shunt Device	X		X
5. Bus section	X		X
6. Bus-tie breaker	X		X
<u>P5 – Multiple Contingency – Relay failure (delayed clearing)</u>			
1. Generator (G-1)	X		X
2. Transmission Circuit (L-1)	X		X
3. Transformer (T-1)	X		X
4. Shunt Device	X		X
5. Bus section	X		X

<u>P6 – Multiple Contingency – P1.2-P1.5 system adjustment and:</u>			
1. Transmission Circuit (L-1)	X	x	X
2. Transformer (T-1)	X	x	X
3. Shunt Device	X		X
4. Bus section	X		X
<u>P7 – Multiple Contingency - Fault plus stuck breaker</u>			
1. Two circuits on common structure (L-2)	X	X	X
2. Bipolar DC line	X	X	X
<u>Extreme event – loss of two or more elements</u>			
Two generators (Common Mode) G-2	X ⁴	X	X ⁴
Any P1.1-P1.3 & P1.5 system readjusted (Common Mode) L-2	X ⁴	X ³	X ⁵
All other extreme combinations.	X ⁴		X ⁴
¹ System must be able to readjust to a safe operating zone in order to be able to support the loss of the next contingency. ² A thermal or voltage criterion violation resulting from a transformer outage may not be cause for a local area reliability requirement if the violation is considered marginal (e.g. acceptable loss of facility life or low voltage), otherwise, such a violation will necessitate creation of a requirement. ³ Evaluate for risks and consequence, per NERC standards. No voltage collapse or dynamic instability allowed. ⁴ Evaluate for risks and consequence, per NERC standards. ⁵ Expanded to include any P1 system readjustment followed by any P7 without stuck breaker. For voltage collapse or dynamic instability situations mitigation is required “if there is a risk of cascading” beyond a relatively small predetermined area – less than 250 MW - directly affected by the outage.			

Table 2.1-2: Criteria Comparison for non-Bulk Electric System contingencies

Contingency Component(s)	Mandatory Reliability Standards	Old Local Capacity Criteria	New Local Capacity Criteria
<u>P0 – No Contingencies</u>	X	X	X
<u>P1 – Single Contingency</u>			
1. Generator (G-1)	X	X ¹	X
2. Transmission Circuit (L-1)	X	X ¹	X
3. Transformer (T-1)	X	X ^{1,2}	X
4. Shunt Device	X		X
5. Single Pole (dc) Line	X	X ¹	X
<u>P2 – Single contingency</u>			
1. Opening a line section w/o a fault			
2. Bus Section fault			
3. Internal Breaker fault (non-Bus-tie Breaker)			
4. Internal Breaker fault (Bus-tie Breaker)			

<u>P3 – Multiple Contingency – G-1 + system adjustment and:</u> 1. Generator (G-1) 2. Transmission Circuit (L-1) 3. Transformer (T-1) 4. Shunt Device 5. Single Pole (dc) Line	X X X X X	X X X ² X	X X X X X
<u>P4 – Multiple Contingency - Fault plus stuck breaker</u> 1. Generator (G-1) 2. Transmission Circuit (L-1) 3. Transformer (T-1) 4. Shunt Device 5. Bus section 6. Bus-tie breaker			
<u>P5 – Multiple Contingency – Relay failure (delayed clearing)</u> 1. Generator (G-1) 2. Transmission Circuit (L-1) 3. Transformer (T-1) 4. Shunt Device 5. Bus section			
<u>P6 – Multiple Contingency – P1.2-P1.5 system adjustment and:</u> 1. Transmission Circuit (L-1) 2. Transformer (T-1) 3. Shunt Device 4. Bus section		x x	
<u>P7 – Multiple Contingency - Fault plus stuck breaker</u> 1. Two circuits on common structure (L-2) 2. Bipolar DC line		X X	
<u>Extreme event – loss of two or more elements</u> Two generators (Common Mode) G-2 Any P1.1-P1.3 & P1.5 system readjusted (Common Mode) L-2 All other extreme combinations.		X X ³	
¹ System must be able to readjust to a safe operating zone in order to be able to support the loss of the next contingency. ² A thermal or voltage criterion violation resulting from a transformer outage may not be cause for a local area reliability requirement if the violation is considered marginal (e.g. acceptable loss of facility life or low voltage), otherwise, such a violation will necessitate creation of a requirement. ³ Evaluate for risks and consequence, per NERC standards. No voltage collapse or dynamic instability allowed.			

A significant number of simulations were run to determine the most critical contingencies within each local area. Using power flow, post-transient load flow, and stability assessment tools, the system performance results of all tested contingencies were measured against the system performance requirements defined by the criteria shown in Tables 1 and 2. Where the specific system performance requirements were not met, generation was adjusted until performance requirements were met for the local area. The adjusted generation constitutes the minimum

generation needed in the local area. The following describes how the criteria were tested for the specific type of analysis performed.

2.1.1 Power Flow Assessment:

Table 2.1-3 Power flow criteria

Contingencies	Thermal Criteria ¹	Voltage Criteria ²
P0	Applicable Rating	Applicable Rating
P1 ³	Applicable Rating	Applicable Rating
P2	Applicable Rating	Applicable Rating
P3	Applicable Rating	Applicable Rating
P4	Applicable Rating	Applicable Rating
P5	Applicable Rating	Applicable Rating
P6 ⁴	Applicable Rating	Applicable Rating
P7	Applicable Rating	Applicable Rating
P1 + P7 ⁴	-	No Voltage Collapse

- ¹ Applicable Rating – Based on CAISO Transmission Register or facility upgrade plans including established Path ratings.
- ² Applicable Rating – CAISO Grid Planning Criteria or facility owner criteria as appropriate.
- ³ Following the first contingency (N-1), the generation must be sufficient to allow the operators to bring the system back to within acceptable operating range (voltage and loading) and/or appropriate OTC following the studied outage conditions and be able to safely prepare for the loss of the next most stringent element and be within Applicable Rating after the loss of the second element.
- ⁴ During normal operation or following the first contingency (N-1), the generation must be sufficient to allow the operators to prepare for the next worst N-1 or common mode N-2 without pre-contingency interruptible or firm load shedding. SPS/RAS/Safety Nets may be utilized to satisfy the criteria after the second N-1 or common mode N-2 except if the problem is of a thermal nature such that short-term ratings could be utilized to provide the operators time to shed either interruptible or firm load.

2.1.2 Post Transient Load Flow Assessment:

Table 2.1-4 Post transient load flow criteria

Contingencies	Reactive Margin Criteria ²
Selected ¹	Applicable Rating

¹ If power flow results indicate significant low voltages for a given power flow contingency, simulate that outage using the post transient load flow program. The post-transient assessment will develop appropriate Q/V and/or P/V curves.

² Applicable Rating – positive margin based on the higher of imports or load increase by 5% for N-1 contingencies, and 2.5% for N-2 contingencies.

2.1.3 Stability Assessment:

Table 2.1-5 Stability criteria

Contingencies	Stability Criteria ²
Selected ¹	Applicable Rating

¹ Base on historical information, engineering judgment and/or if power flow or post transient study results indicate significant low voltages or marginal reactive margin for a given contingency.

² Applicable Rating – CAISO Grid Planning Criteria or facility owner criteria as appropriate.

2.2 Load Forecast

2.2.1 System Forecast

The California Energy Commission (CEC) derives the load forecast at the system and Participating Transmission Owner (PTO) levels. This relevant CEC forecast is then distributed across the entire system, down to the local area, division and substation level. The PTOs use an econometric equation to forecast the system load. The predominant parameters affecting the system load are (1) number of households, (2) economic activity (gross metropolitan products, GMP), (3) temperature and (4) increased energy efficiency and distributed generation programs.

2.2.2 Base Case Load Development Method

The method used to develop the load in the base case is a melding process that extracts, adjusts and modifies the information from the system, distribution and municipal utility forecasts. The melding process consists of two parts: Part 1 deals with the PTO load and Part 2 deals with the

municipal utility load. There may be small differences between the methodologies used by each PTO to disaggregate the CEC load forecast to their level of local area as well as bar-bus model.

2.2.2.1 *PTO Loads in Base Case*

The methods used to determine the PTO loads are, for the most part, similar. One part of the method deals with the determination of the division⁴ loads that would meet the requirements of 1-in-5 or 1-in-10 system or area base cases and the other part deals with the allocation of the division load to the transmission buses.

a. Determination of division loads

The annual division load is determined by summing the previous year division load and the current division load growth. Thus, the key steps are the determination of the initial year division load and the annual load growth. The initial year for the base case development method is based heavily on recorded data. The division load growth in the system base case is determined in two steps. First, the total PTO load growth for the year is determined, as the product of the PTO load and the load growth rate from the system load forecast. Then this total PTO load growth is allocated to the division, based on the relative magnitude of the load growth projected for the divisions by the distribution planners. For example, for the 1-in-10 area base case, the division load growth determined for the system base case is adjusted to the 1-in-10 temperature using the load temperature relation determined from the latest peak load and temperature data of the division.

b. Allocation of division load to transmission bus level

Since the loads in the base case are modeled at the various transmission buses, the division loads developed must be allocated to those buses. The allocation process is different depending on the load types. For the most part, each PTO classifies its loads into four types: conforming, non-conforming, self-generation and generation-plant loads. Since the non-conforming and self-generation loads are assumed to not vary with temperature, their magnitude would be the same in the system or area base cases of the same year. The remaining load (the total division load developed above, less the quantity of non-conforming and self-generation load) is the conforming load. The remaining load is allocated to the transmission buses based on the relative magnitude of the distribution forecast. The summation of all base case loads is generally higher than the load forecast because some load, i.e., self-generation and generation-plant, are behind the meter and must be modeled in the base cases. However, for the most part, metered or aggregated data with telemetry is used to come up with the load forecast.

2.2.2.2 *Municipal Loads in Base Case*

The municipal utility forecasts that have been provided to the CEC and PTOs for the purposes of their base cases were also used for this study.

⁴ Each PTO divides its territory in a number of smaller area named divisions. These are usually smaller and compact areas that have the same temperature profile.

2.3 Power Flow Program Used in the LCR analysis

The technical studies were conducted using General Electric's Power System Load Flow (GE PSLF) program version 21.0_07 and PowerGem's Transmission Adequacy and Reliability Assessment (TARA) program version 1902. This GE PSLF program is available directly from GE or through the Western System Electricity Council (WECC) to any member and TARA program is commercially available.

To evaluate Local Capacity Areas, the starting base case was adjusted to reflect the latest generation and transmission projects as well as the one-in-ten-year peak load forecast for each Local Capacity Area as provided to the CAISO by the PTOs.

Electronic contingency files provided by the PTOs were utilized to perform the numerous contingencies required to identify the LCR. These contingency files include remedial action and special protection schemes that are expected to be in operation during the year of study. A CAISO created EPCL (a GE programming language contained within the GE PSLF package) routine and/or TARA software were used to run the combination of contingencies; however, other routines are available from WECC with the GE PSFL package or can be developed by third parties to identify the most limiting combination of contingencies requiring the highest amount of generation within the local area to maintain power flows within applicable ratings.

3 Locational Capacity Requirement Study Results

3.1 Summary of Study Results

LCR is defined as the amount of resource capacity that is needed within a Local Capacity Area to reliably serve the load located within this area. The results of the CAISO's analysis are summarized in the Executive Summary Tables.

Table 3.1-1 2025 Local Capacity Needs vs. Peak Load and Local Area Resources

	2025 Total LCR (MW)	Peak Load (1 in10) (MW)	2025 LCR as % of Peak Load	Total NQC Local Area Resources (MW)	2025 LCR as % of Total NQC
Humboldt	132	153	86%	191	69%
North Coast/North Bay	837	1481	57%	842	99%
Sierra	1367	1918	71%	2108	65%
Stockton	619	950	65%	619	100%
Greater Bay	6110	10743	57%	7344	83%
Greater Fresno	1971	3279	60%	3392	58%
Kern	186	1651	11%	413	45%
Big Creek/Ventura	1002	4429	23%	3637	28%
LA Basin	6309	18826	34%	7423	85%
San Diego/Imperial Valley	3557	4675	76%	4818	74%
Total	22090	48105	46%	30787	72%

Table 3.1-2 2024 Local Capacity Needs vs. Peak Load and Local Area Resources

	2024 Total LCR (MW)	Peak Load (1 in10) (MW)	2024 LCR as % of Peak Load	Total Dependable Local Area Resources (MW)	2024 LCR as % of Total Area Resources
Humboldt	132	153	86%	197	67%
North Coast/North Bay	706	1537	46%	833	85%
Sierra	1304	1864	70%	2160	60%
Stockton	675	1329	51%	699	97%
Greater Bay	4395	10427	42%	7640	58%
Greater Fresno	1711	3336	51%	3329	51%
Kern	152	903	17%	465	33%
LA Basin	2577	4958	52%	3481	74%
Big Creek/Ventura	6260	19295	32%	8399	75%
San Diego/Imperial Valley	4025	4805	84%	4559	88%
Total	21937	48607	45%	31762	69%

* Value shown only illustrative, since each local area peaks at a different time.

** Resource deficient LCA (or with sub-area that are deficient) – deficiency included in LCR. Resource deficient area implies that in order to comply with the criteria, at summer peak, load must be shed immediately after the first contingency.

Table 3.1-1 and Table 3.1-2 shows how much of the Local Capacity Area load is dependent on local resources and how many local resources must be available in order to serve the load in those Local Capacity Areas in a manner consistent with the Reliability Criteria. These tables also indicate where new transmission projects, new resource additions or demand side management programs would be most useful in order to reduce the dependency on existing, generally older and less efficient local area resources.

The term “Qualifying Capacity” used in this report is the “Net Qualifying Capacity” (“NQC”) posted on the CAISO web site at:

<http://www.caiso.com/planning/Pages/ReliabilityRequirements/Default.aspx>

The NQC list includes the area (if applicable) where each resource is located for units already operational. Neither the NQC list nor this report incorporates Demand Side Management programs and their related NQC. Units scheduled to become operational before June 1 of 2025 have been included in this 2025 Long-Term LCT Study Report and added to the total NQC values for those respective areas (see detail write-up for each area).

Regarding the main tables up front (page 2), the first column, “August Qualifying Capacity,” reflects three sets of resources. The first set is comprised of resources that would normally be expected to be on-line such as Municipal and Regulatory Must-take resources (state, federal, municipal and QFs). The second set is “market” based resources (market, net seller, wind and battery). The third set are solar resources, since they may or may not be available during the actual peak hour for the respective local area. The second column, “Capacity at Peak” identifies how much of the August Qualifying Capacity is expected to be available during the peak time for each particular local area. The third column, “YEAR LCR Need”, sets forth the local capacity requirements, without the deficiencies that must be addressed, necessary to attain a service reliability level required to comply with NERC/WECC/CAISO mandatory reliability standards.

3.2 Summary of Results by Local Area

Each Local Capacity Area’s overall requirement is determined by also achieving each sub-area requirement. Because these areas are a part of the interconnected electric system, the total for each Local Capacity Area is not simply a summation of the sub-area needs. For example, some sub-areas may overlap and therefore the same units may count for meeting the needs in both sub-areas.

3.2.1 Humboldt Area

3.2.1.1 Area Definition

The transmission tie lines into the area include:

- Bridgeville-Cottonwood 115 kV line #1
- Humboldt-Trinity 115 kV line #1
- Laytonville-Garberville 60 kV line #1
- Trinity-Maple Creek 60 kV line #1

The substations that delineate the Humboldt Area are:

- Bridgeville is in, Low Gap, Wildwood and Cottonwood are out
- Humboldt is in, Trinity is out
- Kekawaka and Garberville are in, Laytonville is out
- Maple Creek is in, Trinity and Ridge Cabin are out

3.2.1.1.1 Humboldt LCR Area Diagram

Figure 3.2-1 Humboldt LCR Area

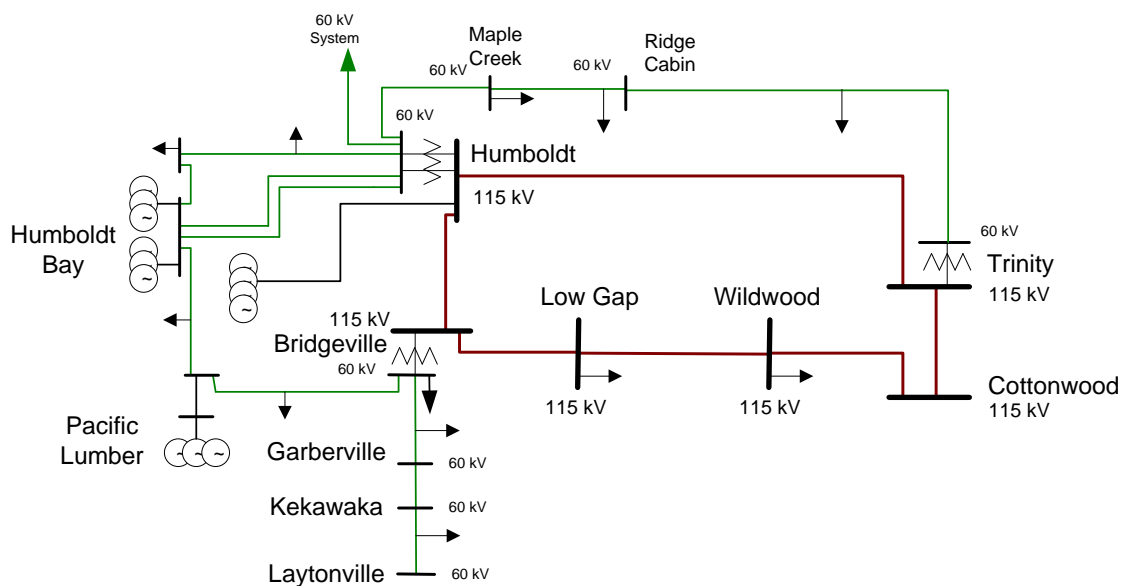

3.2.1.1.2 Humboldt LCR Area Load and Resources

Table 3.2-1 provides the forecasted load and resources. The list of generators within the LCR area are provided in Attachment A.

In year 2025 the estimated time of local area peak is 18:40 PM.

This area does not contain models of solar resources capable of providing resource adequacy.

If required, all non-solar technology type resources are dispatched at NQC.

Table 3.2-1 Humboldt LCR Area 2025 Forecast Load and Resources

Load (MW)		Generation (MW)	Aug NQC	At Peak
Gross Load	151	Market	191	191
AAEE	-8	MUNI	0	0
Behind the meter DG	0	QF	0	0
Net Load	143	LTPP Preferred Resources	0	0
Transmission Losses	10	Existing 20-minute Demand Response	0	0
Pumps	0	Mothballed	0	0
Load + Losses + Pumps	153	Total	191	191

3.2.1.1.3 Humboldt LCR Area Hourly Profiles

Figure 3.2-2 illustrates the forecast 2025 profile for the summer peak, winter peak and spring off-peak days for the Humboldt LCR area with the Category P6 transmission capability without resources. Figure 3.2-3 illustrates the forecast 2025 hourly profile for Humboldt LCR area with the Category P6 transmission capability without resources.

Figure 3.2-2 Humboldt 2025 Peak Day Forecast Profiles

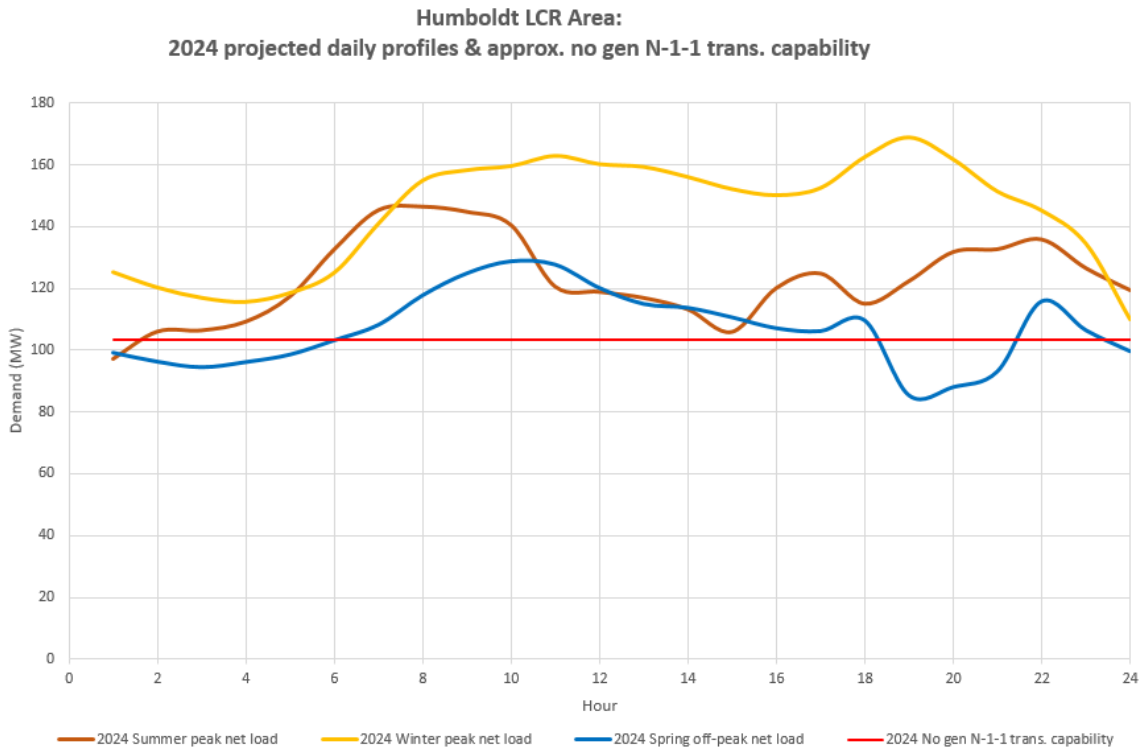
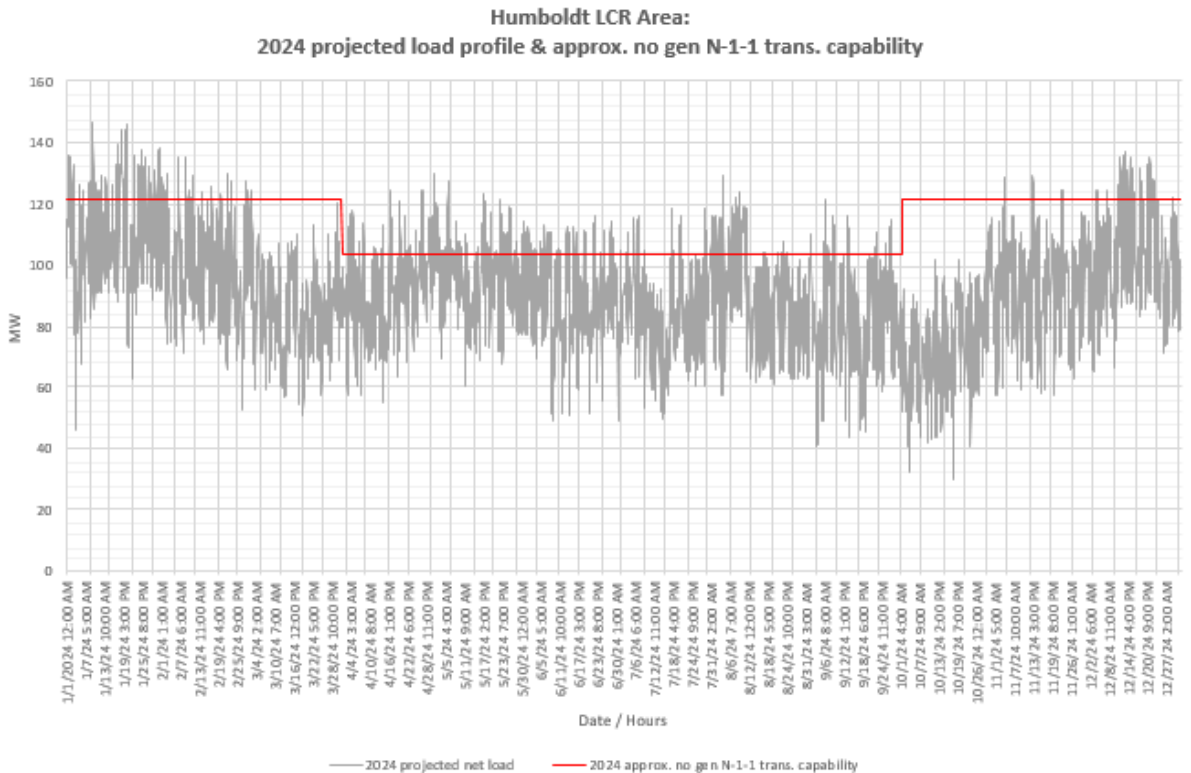

Figure 3.2-3 Humboldt 2025 Forecast Hourly Profile



3.2.1.1.4 Approved transmission projects included in base cases

None

3.2.1.2 Humboldt Overall LCR Requirement

Table 3.2-2 identifies the area LCR requirements. The LCR requirement for Category P6 contingency is 132 MW.

Table 3.2-2 Humboldt LCR Area Requirements

Year	Limit	Category	Limiting Facility	Contingency	LCR (MW) (Deficiency)
2025	First Limit	P6	Humboldt-Trinity 115 kV	Cottonwood-Bridgeville 115 kV & Humboldt - Humboldt Bay 115 kV	132

3.2.1.2.1 Effectiveness factors

For most helpful procurement information please read procedure 2210Z Effectiveness Factors under 7110 (T-138Z) posted at: <http://www.caiso.com/Documents/2210Z.pdf>

3.2.1.2.2 Changes compared to last year’s results

Compared with 2024 the load forecast is the same and so is the LCR need.

3.2.2 North Coast / North Bay Area

3.2.2.1 Area Definition

The transmission tie facilities coming into the North Coast/North Bay area are:

- Cortina-Mendocino 115 kV Line
- Cortina-Eagle Rock 115 kV Line
- Willits-Garberville 60 kV line #1
- Vaca Dixon-Lakeville 230 kV line #1
- Tuluca-Vaca Dixon 230 kV line #1
- Lakeville-Sobrante 230 kV line #1
- Ignacio-Sobrante 230 kV line #1

The substations that delineate the North Coast/North Bay area are:

Cortina is out, Mendocino and Indian Valley are in
 Cortina is out, Eagle Rock, Highlands and Homestake are in
 Willits and Lytonville are in, Kekawaka and Garberville are out
 Vaca Dixon is out, Lakeville is in
 Tulucay is in, Vaca Dixon is out
 Lakeville is in, Sobrante is out
 Ignacio is in, Sobrante and Crocket are out

3.2.2.1.1 North Coast and North Bay LCR Area Diagram

Figure 3.2-4 North Coast and North Bay LCR Area

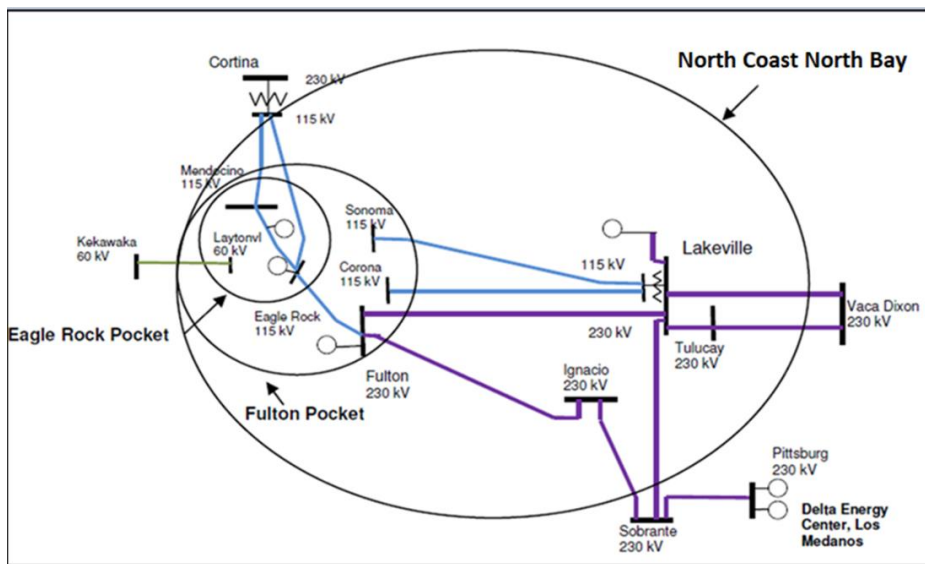

3.2.2.1.2 North Coast and North Bay LCR Area Load and Resources

Table 3.2-3 provides the forecasted load and resources. The list of generators within the LCR area are provided in Attachment A.

In year 2025 the estimated time of local area peak is 18:20 PM.

This area does not contain models of solar resources capable of providing resource adequacy.

If required, all non-solar technology type resources are dispatched at NQC.

Table 3.2-3 North Coast and North Bay LCR Area 2025 Forecast Load and Resources

Load (MW)		Generation (MW)	Aug NQC	At Peak
Gross Load	1458	Market, Net Seller	723	723
AAEE	-16	MUNI	114	114
Behind the meter DG	0	QF	5	5

Net Load	1442	Solar	0	0
Transmission Losses	39	Existing 20-minute Demand Response	0	0
Pumps	0	Mothballed	0	0
Load + Losses + Pumps	1481	Total	842	842

3.2.2.1.3 North Coast and North Bay LCR Area Hourly Profiles

Figure 3.2-5 illustrates the forecast 2025 profile for the peak day for the North Coast North Bay LCR sub-area with the Category P2-4 normal and emergency load serving capabilities without local gas resources. The chart also includes an estimated amount of energy storage that can be added to this local area from charging restriction perspective. Figure 3.2-6 illustrates the forecast 2025 hourly profile for North Coast North Bay LCR sub-area with the Category P2-4 emergency load serving capability without local gas resources.

Figure 3.2-5 North Coast and North Bay 2025 Peak Day Forecast Profiles

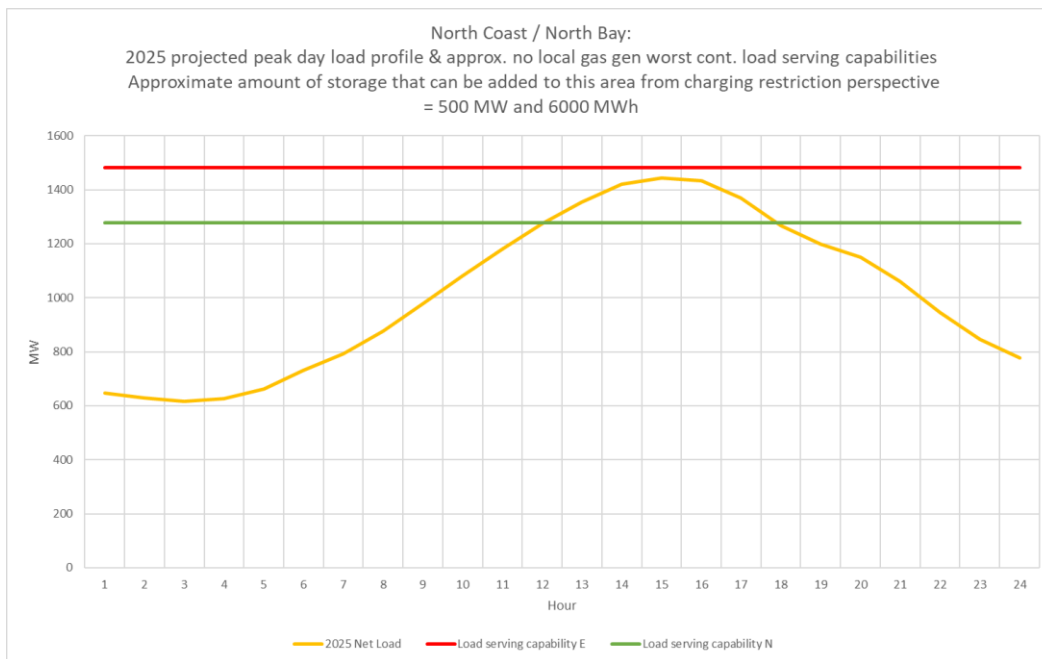
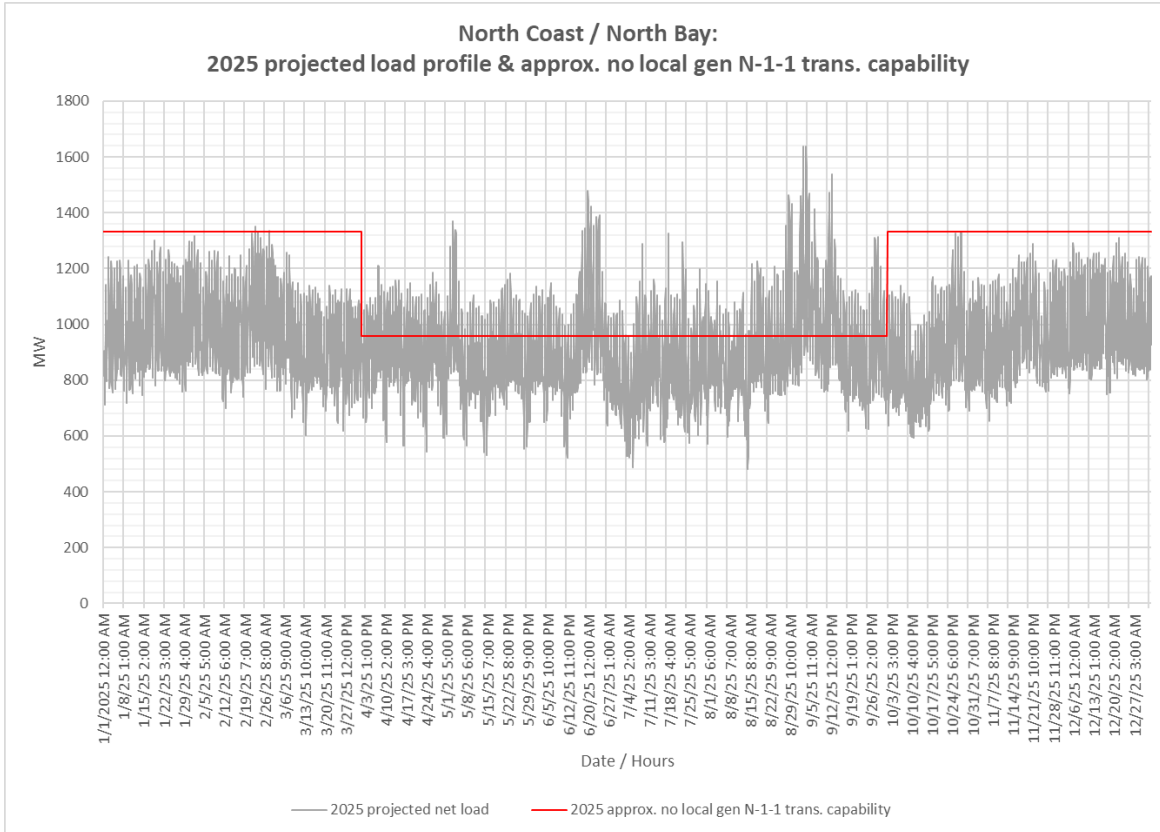

Figure 3.2-6 North Coast and North Bay 2025 Forecast Hourly Profile



3.2.2.1.4 Approved transmission projects modeled in base cases

- Lakeville 60 kV Area Reinforcement
- Clear Lake 60 kV System Reinforcement
- Ignacio Area Upgrade

3.2.2.2 Eagle Rock LCR Sub-area

Eagle Rock is a Sub-area of the North Coast and North Bay LCR Area.

3.2.2.2.1 Eagle Rock LCR Sub-area Diagram

Figure 3.2-7 Eagle Rock LCR Sub-area

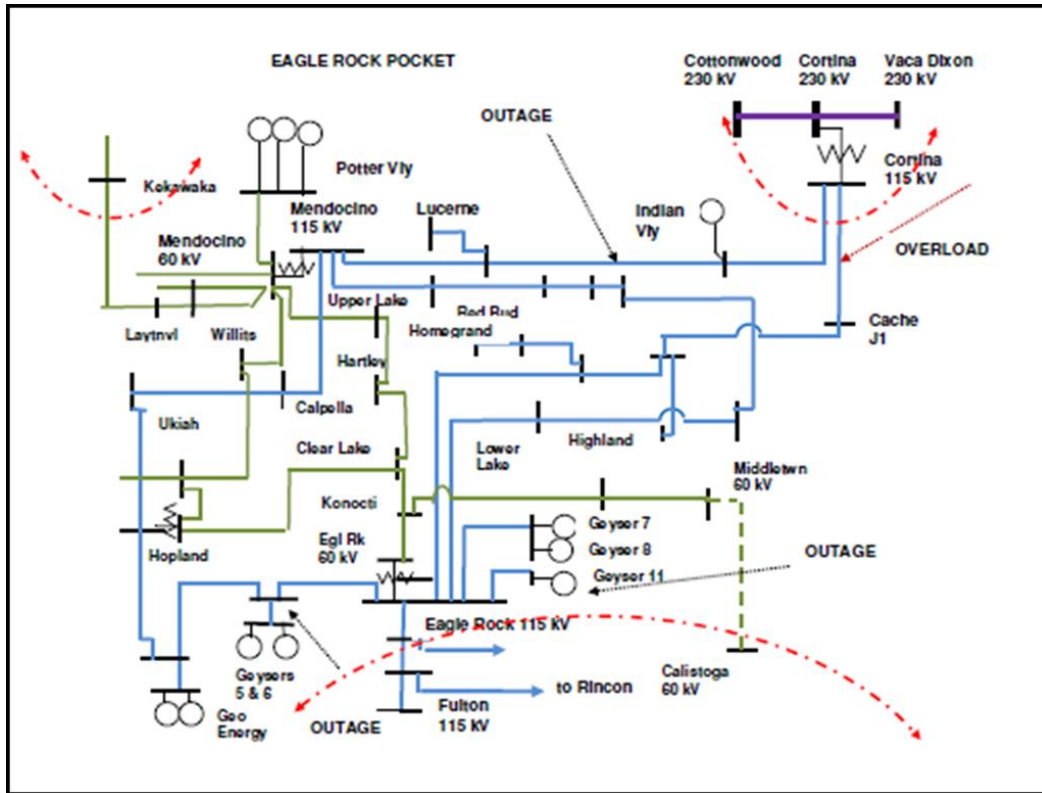

3.2.2.2.2 Eagle Rock LCR sub-area Load and Resources

Table 3.2-4 provides the forecasted load and resources. The list of generators within the LCR sub-area are provided in Attachment A.

Table 3.2-4 Eagle Rock LCR Area 2025 Forecast Load and Resources

Load (MW)		Generation (MW)	Aug NQC	At Peak
Gross Load	226	Market, Net Seller	248	248
AAEE	-2	MUNI	2	2
Behind the meter DG	0	QF	0	0
Net Load	224	Solar	0	0
Transmission Losses	11	Existing 20-minute Demand Response	0	0
Pumps	0	Mothballed	0	0
Load + Losses + Pumps	235	Total	250	250

3.2.2.2.3 Eagle Rock LCR Sub-area Hourly Profiles

Figure 3.2-8 illustrates the forecast 2025 profile for the peak day for the Eagle Rock LCR Sub-area with the Category P3 normal and emergency load serving capabilities without local gas

resources. The chart also includes an estimated amount of energy storage that can be added to this local area from charging restriction perspective. Figure 3.2-9 illustrates the forecast 2025 hourly profile for North Coast North Bay LCR Sub-area with the Category P3 emergency load serving capability without local gas resources.

Figure 3.2-8 Eagle Rock LCR Sub-area 2025 Peak Day Forecast Profiles

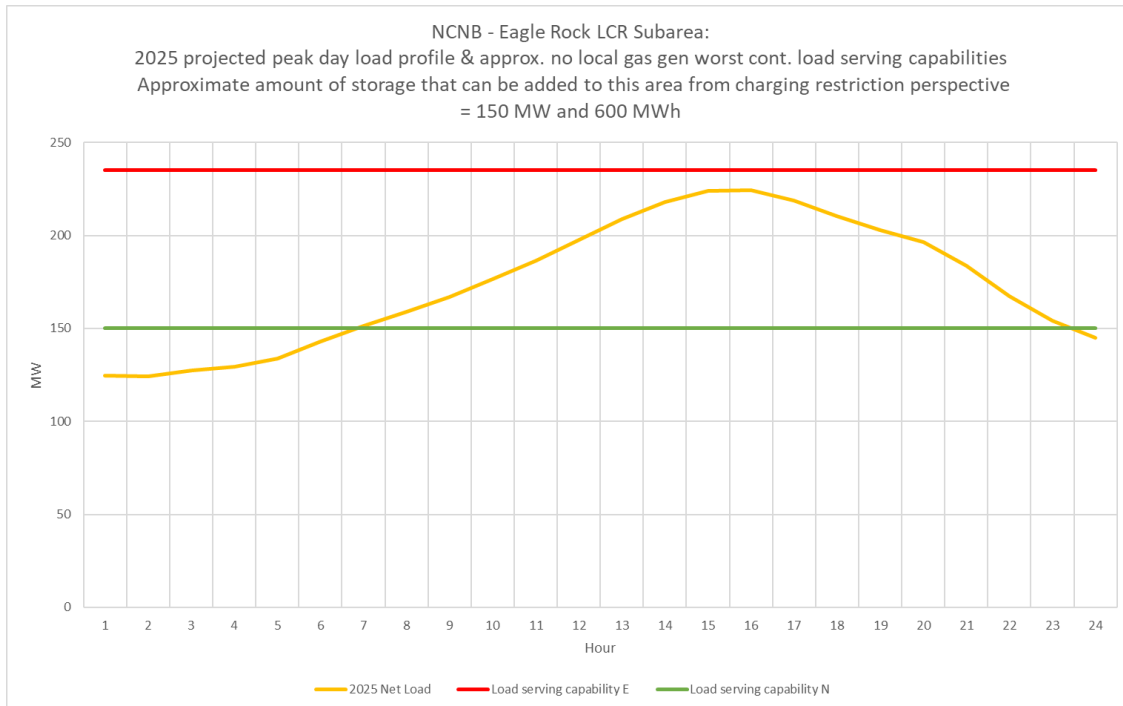
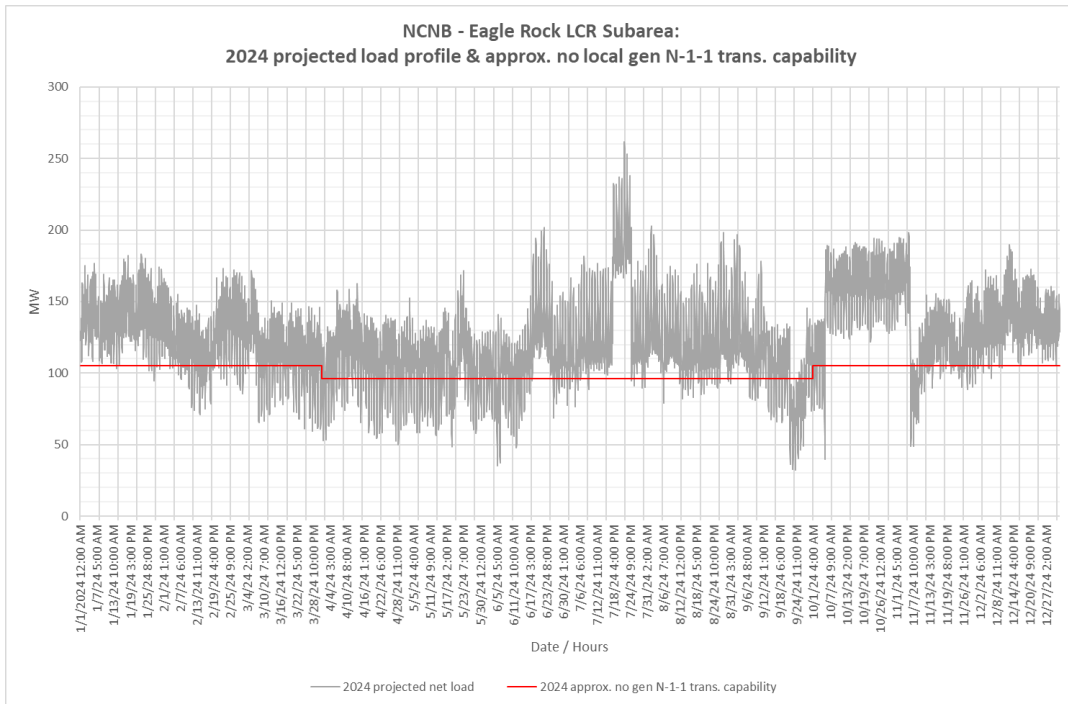
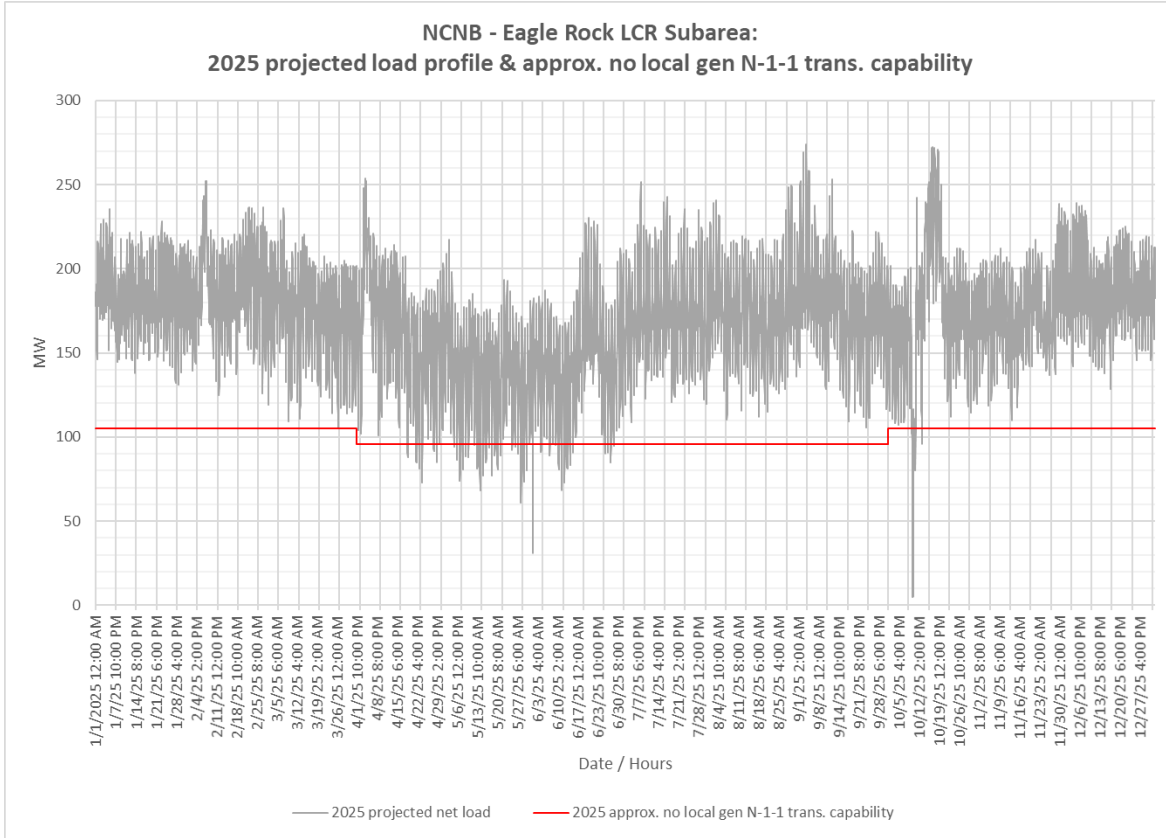

Figure 3.2-9 Eagle Rock LCR Sub-area 2025 Forecast Hourly Profiles



3.2.2.2.4 Eagle Rock LCR Sub-area Requirement

Table 3.2-5 identifies the sub-area LCR requirements. The LCR requirement for Category P3 contingency is 184 MW.

Table 3.2-5 Eagle Rock LCR Sub-area Requirements

Year	Limit	Category	Limiting Facility	Contingency	LCR (MW) (Deficiency)
2025	First Limit	P3	Eagle Rock-Cortina 115 kV line	Cortina-Mendocino 115 kV with Geyser #11 unit out	184

3.2.2.2.5 Effectiveness factors

Effectiveness factors for generators in the Eagle Rock LCR sub-area are in Attachment B table titled [Eagle Rock](#).

For most helpful procurement information please read procedure 2210Z Effectiveness Factors under 7110 (T-138Z) posted at: <http://www.caiso.com/Documents/2210Z.pdf>

3.2.2.3 Fulton Sub-area

Fulton is a Sub-area of the North Coast and North Bay LCR Area.

3.2.2.3.1 Fulton LCR Sub-area Diagram

Figure 3.2-10 Fulton LCR Sub-area

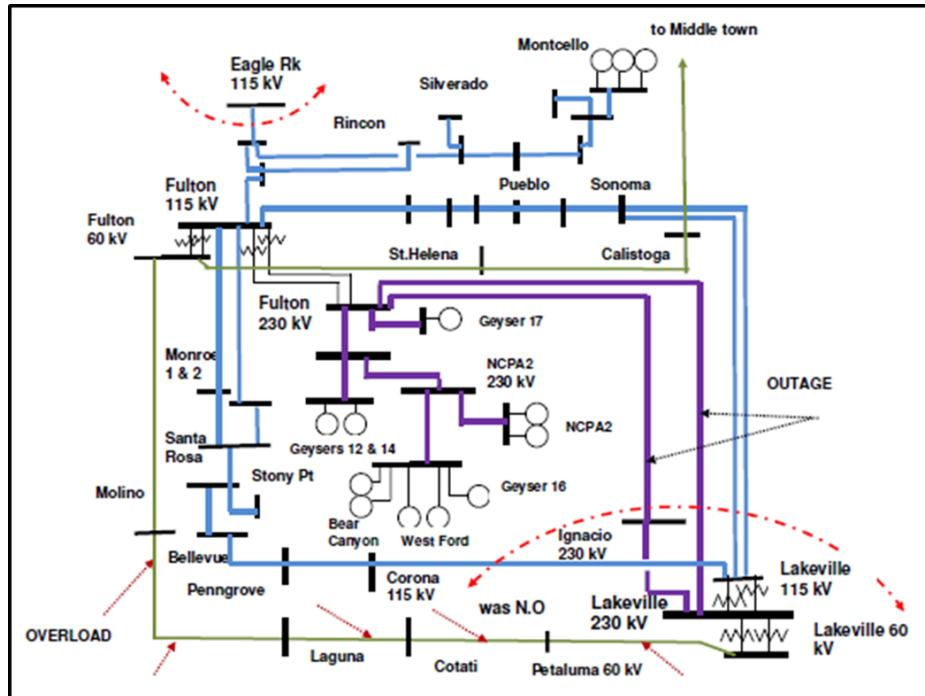

3.2.2.3.2 Fulton LCR Sub-area Load and Resources

Table 3.2-6 provides the forecasted load and resources. The list of generators within the LCR sub-area are provided in Attachment A.

Table 3.2-6 Fulton LCR Area 2025 Forecast Load and Resources

Load (MW)		Generation (MW)	Aug NQC	At Peak
Gross Load	859	Market, Net Seller	469	469
AAEE	-9	MUNI	54	54
Behind the meter DG	0	QF	5	5
Net Load	850	Solar	0	0
Transmission Losses	22	Existing 20-minute Demand Response	0	0
Pumps	0	Mothballed	0	0
Load + Losses + Pumps	872	Total	528	528

3.2.2.3.3 Fulton LCR Sub-area Hourly Profiles

Figure 3.2-11 illustrates the forecast 2025 profile for the peak day for the Fulton LCR Sub-area with the Category P6 normal and emergency load serving capabilities without local gas resources. The chart also includes an estimated amount of energy storage that can be added to this local area from charging restriction perspective. Figure 3.2-12 illustrates the forecast 2025 hourly

profile for North Coast North Bay LCR Sub-area with the Category P6 emergency load serving capability without local gas resources.

Figure 3.2-11 Fulton LCR Sub-area 2025 Peak Day Forecast Profiles

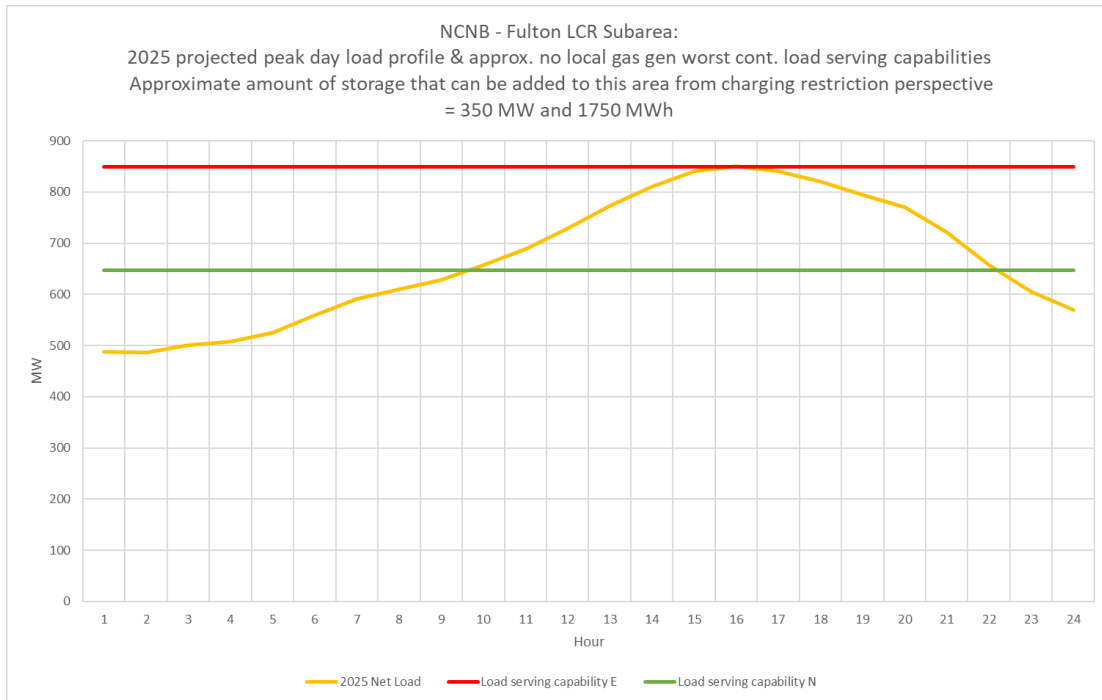
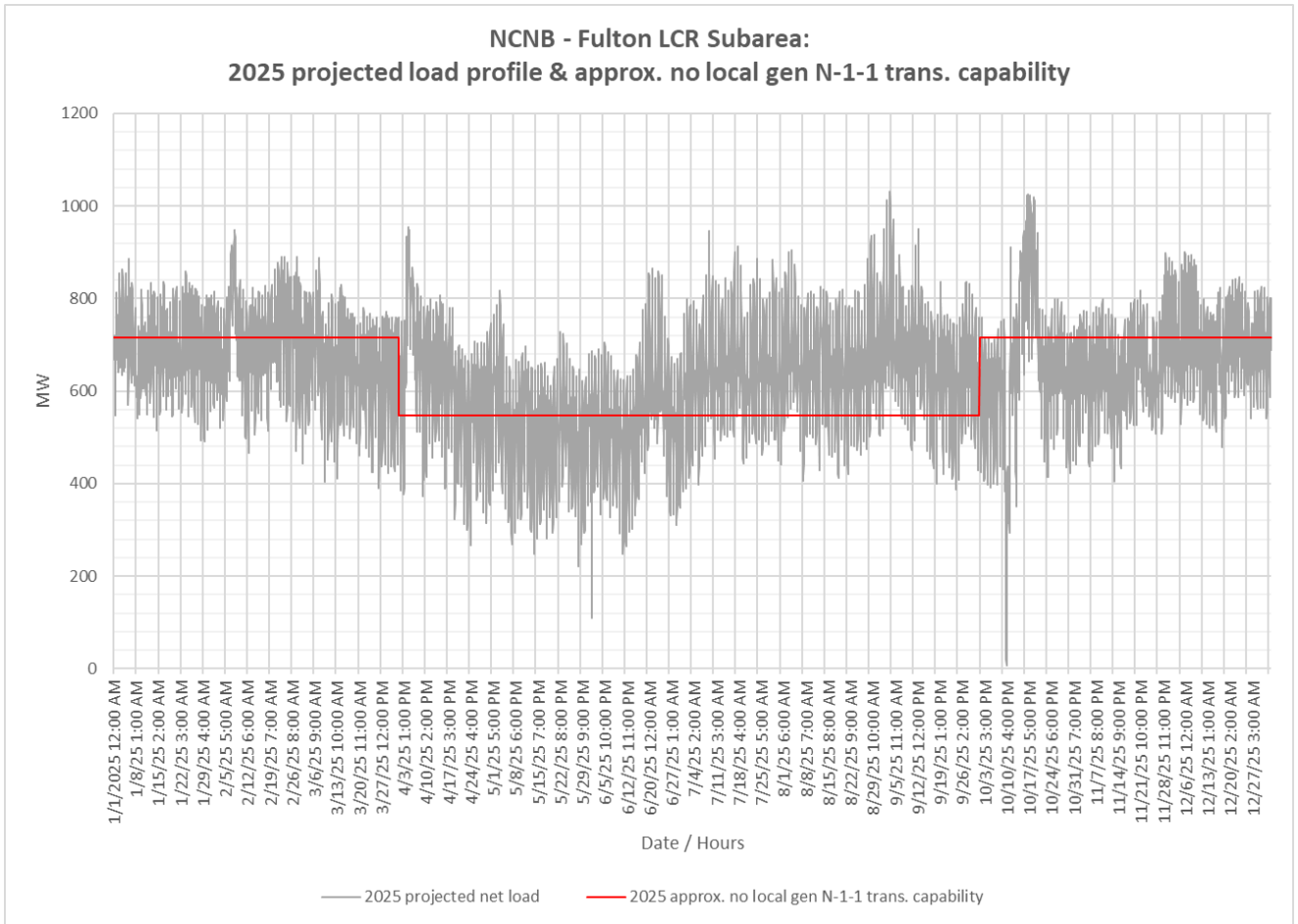

Figure 3.2-12 Fulton LCR Sub-area 2025 Forecast Hourly Profiles



3.2.2.3.4 Fulton LCR Sub-area Requirement

Table 3.2-7 identifies the sub-area LCR requirements. The LCR requirement for Category P6 contingency is 272 MW. There is a significant LCR reduction because of the Lakeville 60 kV Area Reinforcement project in service in 2021 – to open the 60 kV line between Cotati and Petaluma.

Table 3.2-7 Fulton LCR Sub-area Requirements

Year	Limit	Category	Limiting Facility	Contingency	LCR (MW) (Deficiency)
2025	First Limit	P6	Pengrove-Corona 115 kV line	Fulton-Lakeville #1 230 kV & Fulton-Ignacio #1 230 kV	272

3.2.2.3.5 Effectiveness factors

Effectiveness factors for generators in the Fulton LCR sub-area are in Attachment B table titled [Fulton](#).

For most helpful procurement information please read procedure 2210Z Effectiveness Factors under 7110 (T-138Z) posted at: <http://www.caiso.com/Documents/2210Z.pdf>

3.2.2.4 North Coast and North Bay Overall

Lakeville Sub-area represents the North Coast and North Bay LCR overall requirement.

3.2.2.4.1 North Coast and North Bay Overall Requirement

Table 3.2-8 identifies the sub-area LCR requirements. The LCR requirement for Category P2-4 contingency is 837 and for Category P3 contingency are 739 MW.

Table 3.2-8 North Coast and North Bay LCR area Requirements

Year	Limit	Category	Limiting Facility	Contingency	LCR (MW) (Deficiency)
2025	First Limit	P2-4	Tulucay - Vaca Dixon 230 kV Line	Lakeville 230kV – Section 2E & 1E	837
2025	Second Limit	P3	Vaca Dixon-Lakeville 230 kV	Vaca Dixon-Tulucay 230 kV with DEC power plant out of service	739

3.2.2.4.2 Effectiveness factors

Effectiveness factors for generators in the Lakeville LCR Sub-area and North Coast and North Bay LCR area are in Attachment B table titled [Lakeville](#).

For most helpful procurement information please read procedure 2210Z Effectiveness Factors under 7110 (T-138Z) posted at: <http://www.caiso.com/Documents/2210Z.pdf>

3.2.2.4.3 Changes compared to last year’s results

Compared to 2024 load forecast went down by 56 MW; however, the total LCR need went up by 131 MW due to new contingency methodology (irrespective of) load decrease LCR criteria.

3.2.3 Sierra Area

3.2.3.1 Area Definition

The transmission tie lines into the Sierra Area are:

- Table Mountain-Rio Oso 230 kV line
- Table Mountain-Palermo 230 kV line
- Table Mt-Pease 60 kV line
- Caribou-Palermo 115 kV line
- Drum-Summit 115 kV line #1
- Drum-Summit 115 kV line #2
- Spaulding-Summit 60 kV line
- Brighton-Bellota 230 kV line
- Rio Oso-Lockeford 230 kV line
- Gold Hill-Eight Mile Road 230 kV line
- Lodi-Eight Mile Road 230 kV line
- Gold Hill-Lake 230 kV line

The substations that delineate the Sierra Area are:

- Table Mountain is out Rio Oso is in
- Table Mountain is out Palermo is in
- Table Mt is out Pease is in
- Caribou is out Palermo is in
- Drum is in Summit is out
- Drum is in Summit is out
- Spaulding is in Summit is out
- Brighton is in Bellota is out
- Rio Oso is in Lockeford is out
- Gold Hill is in Eight Mile is out
- Lodi is in Eight Mile is out
- Gold Hill is in Lake is out

3.2.3.1.1 Sierra LCR Area Diagram

Figure 3.2-13 Sierra LCR Area

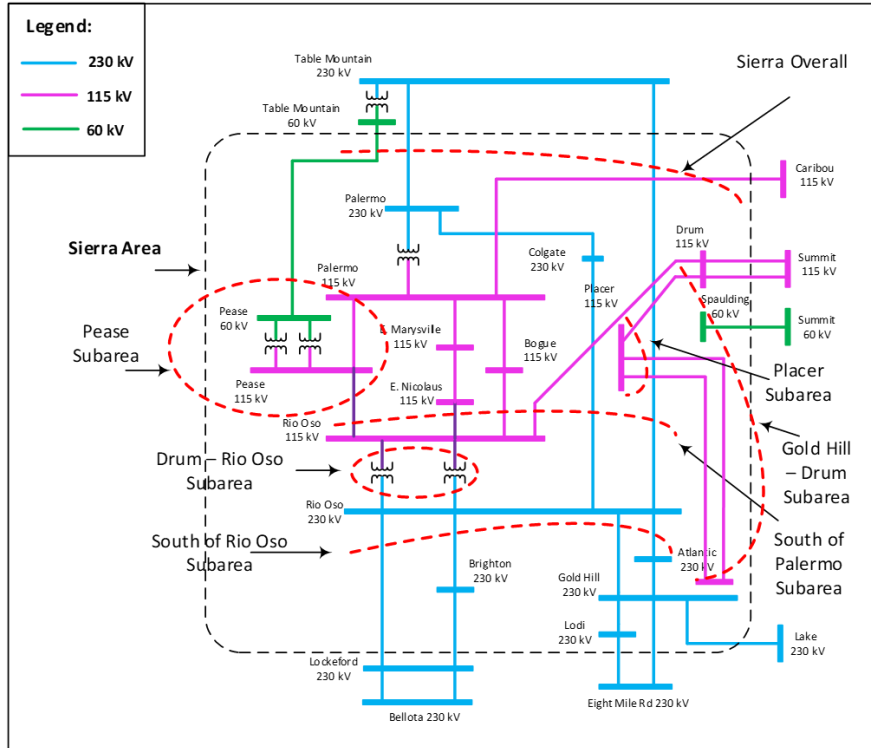

3.2.3.1.2 Sierra LCR Area Load and Resources

Table 3.2-9 provides the forecasted load and resources. The list of generators within the LCR area are provided in Attachment A.

In year 2025 the estimated time of local area peak is 19:00 PM.

At the local area peak time the estimated, ISO metered, solar output is 2.00%.

If required, all non-solar technology type resources are dispatched at NQC.

Table 3.2-9 Sierra LCR Area 2025 Forecast Load and Resources

Load (MW)		Generation (MW)	Aug NQC	At Peak
Gross Load	1849	Market, Net Seller	920	920
AAEE	-16	MUNI	1142	1142
Behind the meter DG	0	QF	41	41
Net Load	1833	Solar	5	0
Transmission Losses	85	Existing 20-minute Demand Response	0	0
Pumps	0	Mothballed	0	0
Load + Losses + Pumps	1918	Total	2108	2103

3.2.3.1.3 Approved transmission projects modeled:

- Rio Oso 230/115 kV transformer upgrade
- Pease 115/60 kV transformer addition
- South of Palermo 115 kV Reinforcement
- Vaca Dixon Area Reinforcement
- Rio Oso Area 230 kV Voltage Support
- East Marysville 115/60 kV
- Gold Hill 230/115 kV Transformer Addition

3.2.3.2 Placer Sub-area

Placer is Sub-area of the Sierra LCR Area.

3.2.3.2.1 Placer LCR Sub-area Diagram

Figure 3.2-14 Placer LCR Sub-area

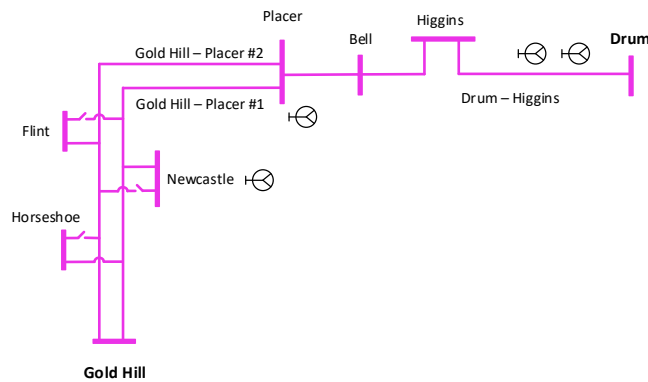

3.2.3.2.2 Placer LCR Sub-area Load and Resources

Table 3.2-10 provides the forecasted load and resources. The list of generators within the LCR sub-area are provided in Attachment A.

Table 3.2-10 Placer LCR Sub-area 2025 Forecast Load and Resources

Load (MW)		Generation (MW)	Aug NQC	At Peak
Gross Load	175	Market, Net Seller	54	54
AAEE	-1	MUNI	42	42
Behind the meter DG	0	QF	0	0
Net Load	174	Solar	0	0
Transmission Losses	5	Existing 20-minute Demand Response	0	0

Pumps	0	Mothballed	0	0
Load + Losses + Pumps	179	Total	96	96

3.2.3.2.3 Placer LCR Sub-area Hourly Profiles

Figure 3.2-15 illustrates the forecast 2025 profile for the peak day for the Placer LCR sub-area with the Category P6 normal and emergency capabilities without local gas resources. The chart also includes an estimated amount of energy storage that can be added to this local area from charging restriction perspective. Figure 3.2-16 illustrates the forecast 2025 hourly profile for Placer LCR sub-area with the Category P6 emergency load serving capability without local gas resources.

Figure 3.2-15 Placer LCR Sub-area 2025 Peak Day Forecast Profiles

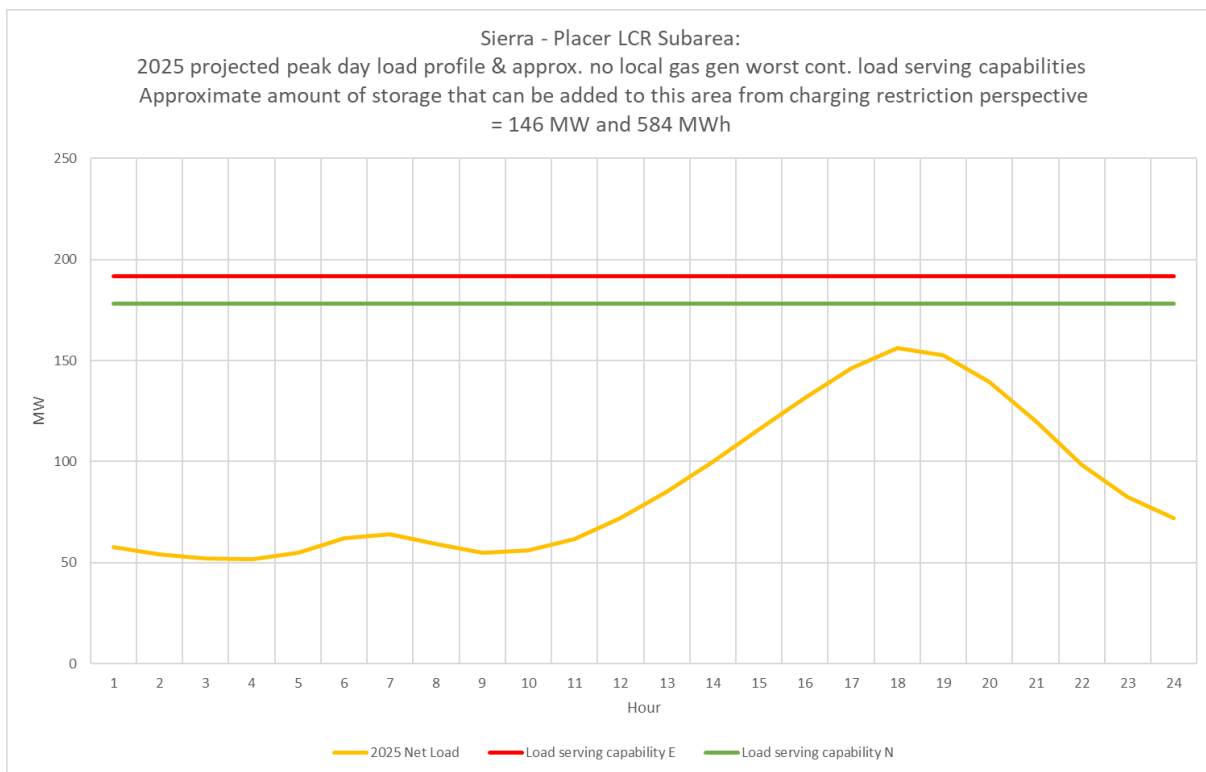
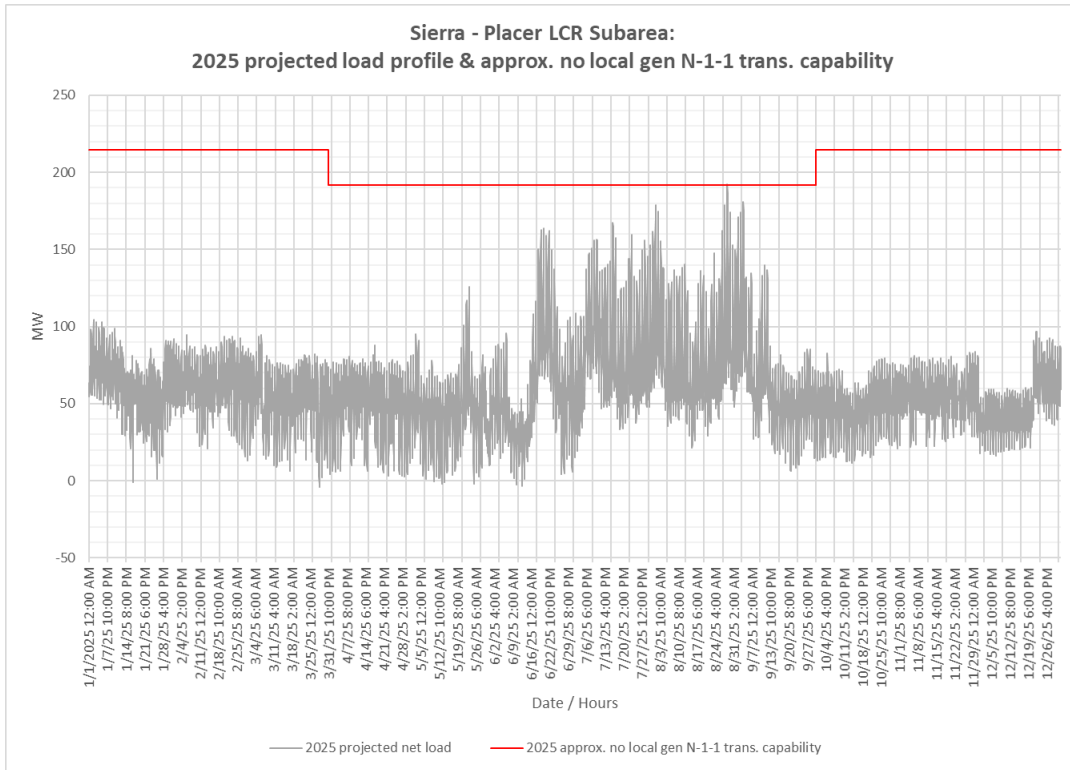

Figure 3.2-16 Placer LCR Sub-area 2025 Forecast Hourly Profiles



3.2.3.2.4 Placer LCR Sub-area Requirement

Table 3.2-11 identifies the sub-area LCR requirements. The LCR requirement for Category P6 contingency is 93 MW.

Table 3.2-11 Placer LCR Sub-area Requirements

Year	Limit	Category	Limiting Facility	Contingency	LCR (MW) (Deficiency)
2025	First Limit	P6	Drum-Higgins 115 kV	Gold Hill-Placer #1 115 kV & Gold Hill-Placer #2 115 kV	93

3.2.3.2.5 Effectiveness factors

All units within the Placer Sub-area have the same effectiveness factor.

For most helpful procurement information please read procedure 2210Z Effectiveness Factors under 7240 posted at: <http://www.aiso.com/Documents/2210Z.pdf>

3.2.3.3 Pease Sub-area

Pease is Sub-area of the Sierra LCR Area.

Pease Sub-area will be eliminated due to the East Marysville 115/60 kV transmission project .

3.2.3.4 Drum-Rio Oso Sub-area

Drum-Rio Oso is a Sub-area of the Sierra LCR Area.

Drum-Rio Oso Sub-area will be eliminated due to the Rio Oso 230/115 kV transformer upgrade transmission project.

3.2.3.5 Gold Hill-Drum Sub-area

Gold Hill-Drum is Sub-area of the Sierra LCR Area.

3.2.3.5.1 Gold Hill-Drum LCR Sub-area Diagram

Figure 3.2-17 Gold Hill-Drum LCR Sub-area

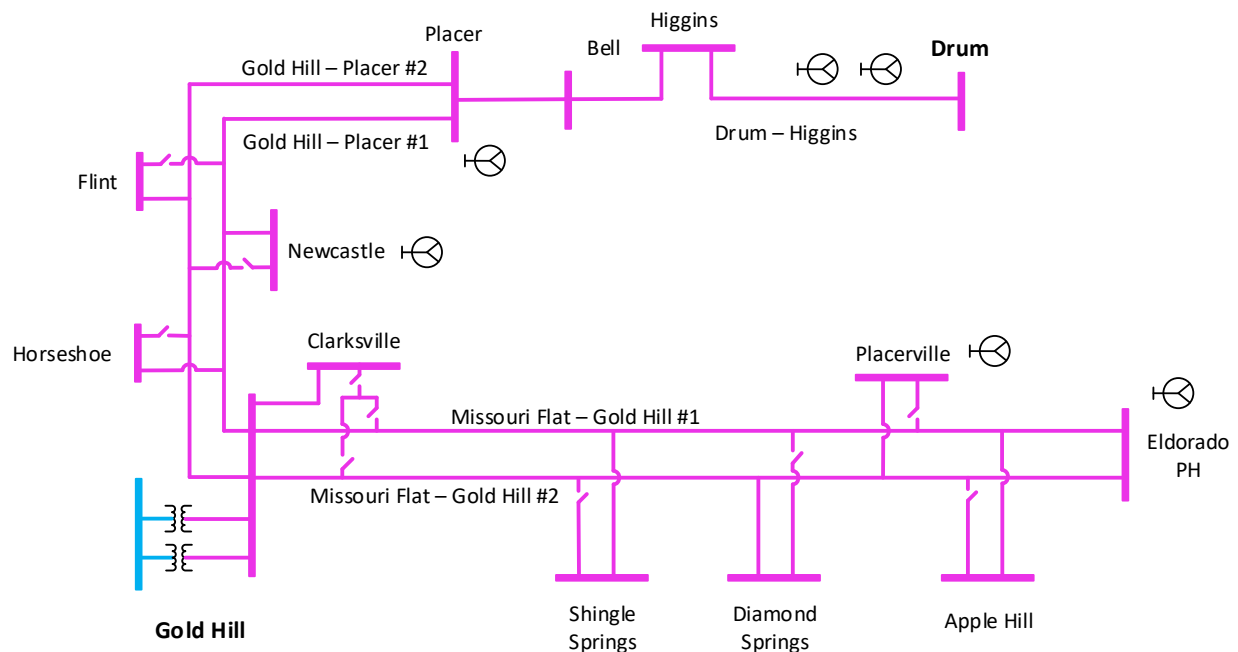

3.2.3.5.2 Gold Hill-Drum LCR Sub-area Load and Resources

Table 3.2-12 provides the forecasted load and resources. The list of generators within the LCR sub-area are provided in Attachment A.

Table 3.2-12 Gold Hill-Drum LCR Sub-area 2025 Forecast Load and Resources

Load (MW)		Generation (MW)	Aug NQC	At Peak
Gross Load	507	Market and Net Seller	85	85
AAEE	-4	MUNI	42	42
Behind the meter DG	0	QF	0	0
Net Load	503	Solar	0	0

Transmission Losses	9	Existing 20-minute Demand Response	0	0
Pumps	0	Mothballed	0	0
Load + Losses + Pumps	512	Total	127	127

3.2.3.5.3 Gold Hill-Drum LCR Sub-area Hourly Profiles

Figure 3.2-18 illustrates the forecast 2025 profile for the peak day for the Gold Hill-Drum LCR sub-area with the Category P6 normal and emergency load serving capabilities without local gas resources. The chart also includes an estimated amount of energy storage that can be added to this local area from charging restriction perspective. Figure 3.2-19 illustrates the forecast 2021 hourly profile for Gold Hill-Drum LCR sub-area with the Category P6 load serving capability without local gas resources.

Figure 3.2-18 Gold Hill-Drum LCR Sub-area 2025 Peak Day Forecast Profiles

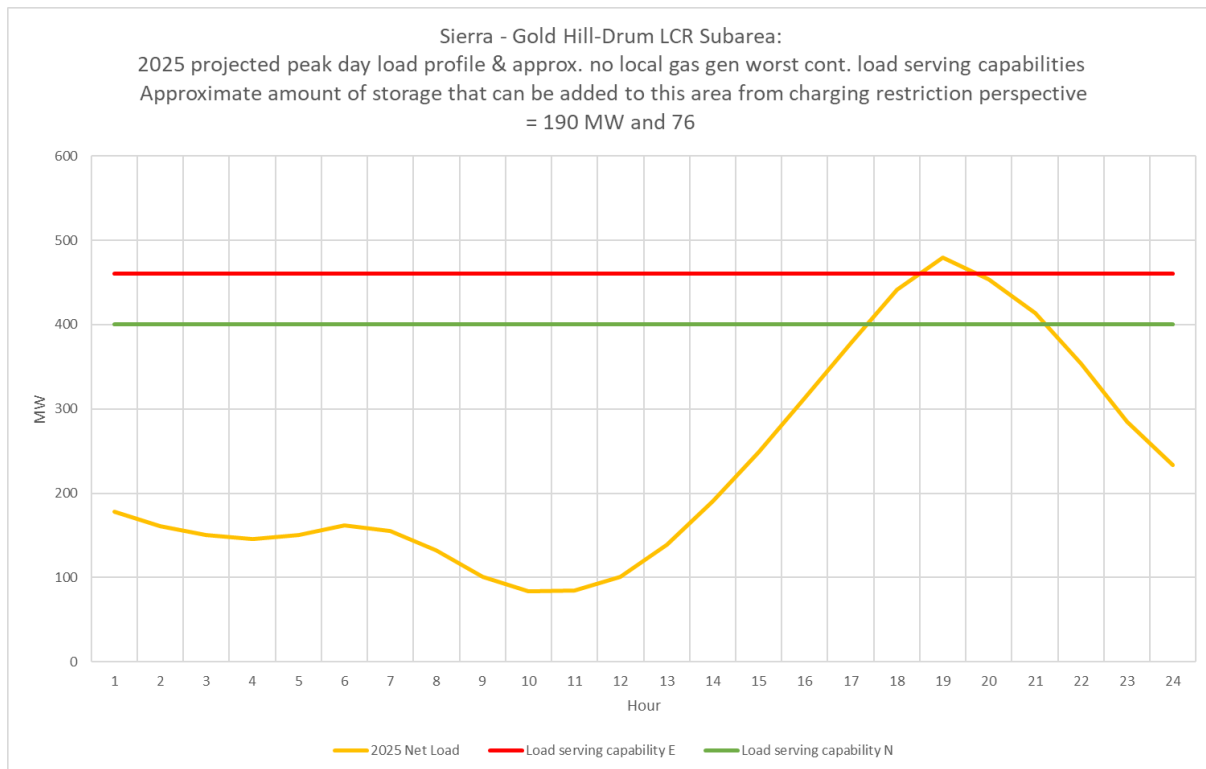
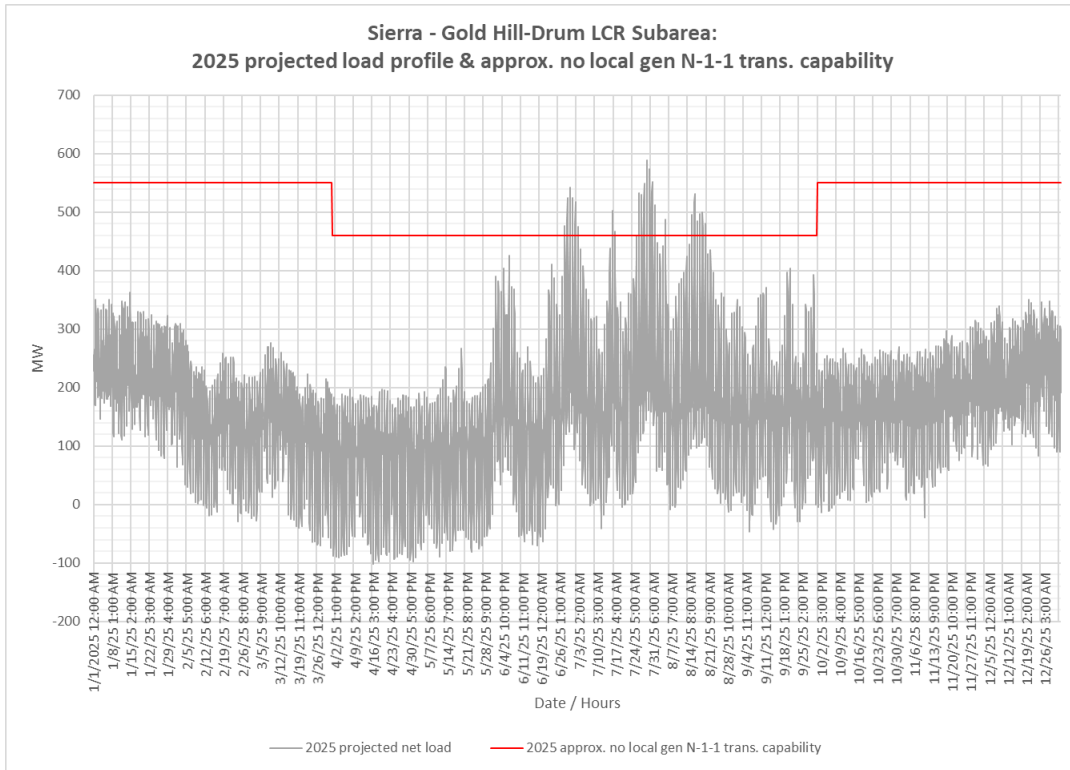

Figure 3.2-19 Gold Hill-Drum LCR Sub-area 2025 Forecast Hourly Profiles



3.2.3.5.4 Gold Hill-Drum LCR Sub-area Requirement

Table 3.2-13 identifies the sub-area LCR requirements. The Category P6 LCR requirement is 142 MW including 45 MW of NQC and peak deficiency .

Table 3.2-13 Gold Hill-Drum LCR Sub-area Requirements

Year	Limit	Category	Limiting Facility	Contingency	LCR (MW) (Deficiency)
2025	First Limit	P6	Drum – Higgins 115 kV	Bus-tie-breaker (P2-4) at Gold Hill 115 kV substation	142 (45)

3.2.3.5.5 Effectiveness factors:

All units within the Gold Hill-Drum sub-area have the same effectiveness factor.

For most helpful procurement information please read procedure 2210Z Effectiveness Factors under 7230 posted at: <http://www.aiso.com/Documents/2210Z.pdf>

3.2.3.6 South of Rio Oso Sub-area

South of Rio Oso is a Sub-area of the Sierra LCR Area.

3.2.3.6.1 South of Rio Oso LCR Sub-area Diagram

Figure 3.2-20 South of Rio Oso LCR Sub-area

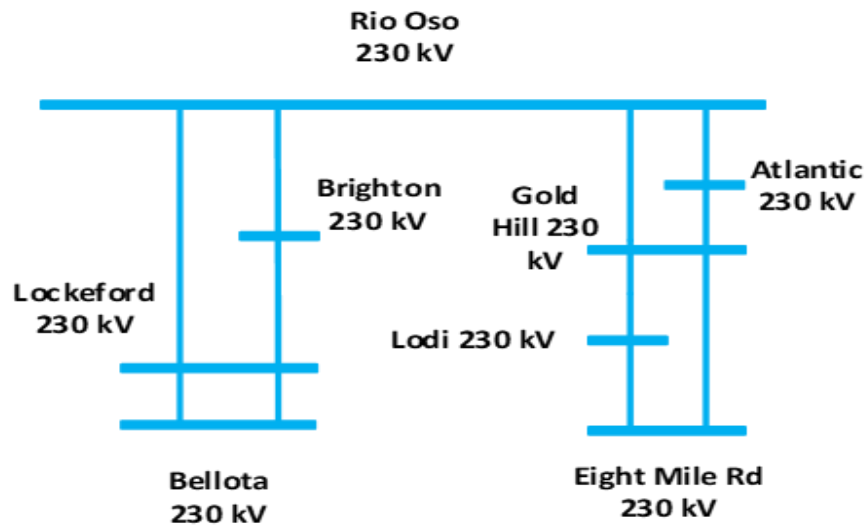

3.2.3.6.2 South of Rio Oso LCR Sub-area Load and Resources

The South of Rio Oso sub-area does not have a defined load pocket with the limits based upon power flow through the area. Table 3.2-14 provides the forecasted resources in the sub-area. The list of generators within the LCR area are provided in Attachment A.

Table 3.2-14 South of Rio Oso LCR Sub-area 2025 Forecast Load and Resources

Load (MW)	Generation (MW)	Aug NQC	At Peak
The South of Rio Oso Sub-area does not have a defined load pocket with the limits based upon power flow through the area.	Market	122	122
	MUNI	621	621
	QF	0	0
	LTPP Preferred Resources	0	0
	Existing 20-minute Demand Response	0	0
	Mothballed	0	0
	Total	743	743

3.2.3.6.3 South of Rio Oso LCR Sub-area Hourly Profiles

The South of Rio Oso Sub-area does not have a defined load pocket with the limits based upon power flow through the area. As such, no load profile is provided for this sub-area.

3.2.3.6.4 South of Rio Oso LCR Sub-area Requirement

Table 3.2-15 identifies the sub-area LCR requirements. The LCR requirements for Category P6 contingency is 223 MW.

Table 3.2-15 South of Rio Oso LCR Sub-area Requirements

Year	Limit	Category	Limiting Facility	Contingency	LCR (MW) (Deficiency)
2025	First limit	P6	Rio Oso – Atlantic 230 kV	Rio Oso – Gold Hill 230 kV Rio Oso – Brighton 230 kV	223

3.2.3.6.5 Effectiveness factors:

Effectiveness factors for generators in the South of Rio Oso LCR sub-area are in Attachment B table titled [Rio Oso](#).

For other helpful procurement information please read procedure 2210Z Effectiveness Factors under 7230 (T-165Z) posted at: <http://www.caiso.com/Documents/2210Z.pdf>

3.2.3.7 South of Palermo Sub-area

South of Palermo sub-area will be eliminated due to the South of Palermo transmission project.

3.2.3.8 Sierra Area Overall

3.2.3.8.1 Sierra LCR Area Hourly Profiles

The Sierra LCR Area limits are based upon power flow through the area. As such, no load profile is provided for the area.

3.2.3.8.2 Sierra LCR Area Requirement

Table 3.2-16 identifies the area requirements. The LCR requirement for Category P6 contingency is 1367 MW.

Table 3.2-16 Sierra Area Requirements

Year	Limit	Category	Limiting Facility	Contingency	LCR (MW) (Deficiency)
2025	First limit	P6	Table Mountain – Pease 60 kV	Table Mountain – Palermo 230 kV Table Mountain – Rio Oso 230 kV	1367

3.2.3.8.3 Effectiveness factors:

Effectiveness factors for generators in the Sierra overall area are in Attachment B table titled [Sierra Overall](#).

For other helpful procurement information please read procedure 2210Z Effectiveness Factors under 7230 (T-165Z) posted at: <http://www.caiso.com/Documents/2210Z.pdf>

3.2.3.8.4 Changes compared to last year's results:

The load forecast went up by 54 MW. The total LCR need has increased by 109 MW and the total existing capacity required has increased by 63 MW mostly due to increase in load forecast.

3.2.4 Stockton Area

The LCR requirement for the Stockton Area is driven by the Tesla-Bellota sub-area.

3.2.4.1 Area Definition

Tesla-Bellota Sub-Area Definition

The transmission facilities that establish the boundary of the Tesla-Bellota sub-area are:

Bellota 230/115 kV Transformer #1

Bellota 230/115 kV Transformer #2

Tesla-Tracy 115 kV Line

Tesla-Salado 115 kV Line

Tesla-Salado-Manteca 115 kV line

Tesla-Schulte #1 115 kV Line

Tesla-Schulte #2 115kV line

The substations that delineate the Tesla-Bellota Sub-area are:

Bellota 230 kV is out Bellota 115 kV is in

Bellota 230 kV is out Bellota 115 kV is in

Tesla is out Tracy is in

Tesla is out Salado is in

Tesla is out Salado and Manteca are in

Tesla is out Schulte is in

Tesla is out Schulte is in

3.2.4.1.1 Stockton LCR Area Diagram

The Stockton LCR Area is comprised of the individual noncontiguous sub-areas with diagrams provided for each of the sub-areas below.

3.2.4.1.2 Stockton LCR Area Load and Resources

Table 3.2-17 provides the forecast load and resources in the area. The list of generators within the LCR area are provided in Attachment A.

In year 2025 the estimated time of local area peak is 19:10 PM.

At the local area peak time the estimated, ISO metered, solar output is 2.00%.

If required, all non-solar technology type resources are dispatched at NQC.

Table 3.2-17 Stockton LCR Area 2025 Forecast Load and Resources

Load (MW)		Generation (MW)	NQC	At Peak
Gross Load	938	Market, Net Seller	491	491
AAEE	-7	MUNI	116	116
Behind the meter DG	0	QF	0	0
Net Load	931	Solar	12	0
Transmission Losses	19	Existing 20-minute Demand Response	0	0
Pumps	0	Mothballed	0	0
Load + Losses + Pumps	950	Total	619	607

3.2.4.1.3 Stockton LCR Area Hourly Profiles

The Stockton LCR Area is comprised of the individual noncontiguous sub-areas with profiles provided for each of the sub-areas below.

3.2.4.1.4 Approved transmission projects modeled

Weber-Stockton "A" #1 and #2 60 kV Reconductoring

Ripon 115 kV line

Vierra 115 kV Looping Project

Tesla 230 kV Bus Series Reactor

Lockeford-Lodi Area 230 kV Development

3.2.4.2 Weber Sub-area

Weber sub-area has been eliminated due to change in LCR criteria.

3.2.4.3 Lockeford Sub-area

Lockeford sub-area will be eliminated due to the Lockeford-Lodi Area 230 kV Development transmission project.

3.2.4.4 Stanislaus Sub-area

Stanislaus is a Sub-area within the Tesla-Bellota Sub-area of the Stockton LCR Area.

3.2.4.4.1 Stanislaus LCR Sub-area Diagram

Figure 3.2-21 Stanislaus LCR Sub-area

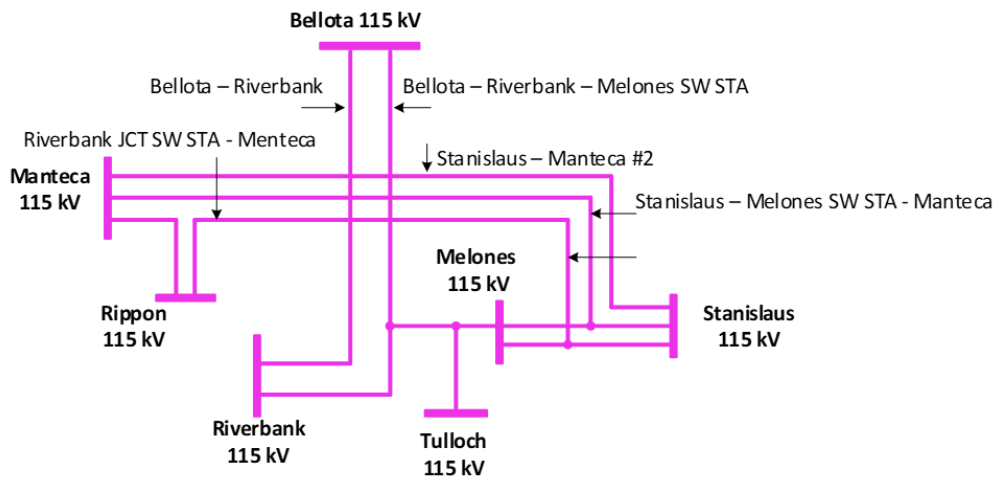

3.2.4.4.2 Stanislaus LCR Sub-area Load and Resources

The Stanislaus sub-area does not have a defined load pocket with the limits based upon power flow through the area. Table 3.2-18 provides the forecasted resources in the sub-area. The list of generators within the LCR sub-area are provided in Attachment A.

Table 3.2-18 Stanislaus LCR Sub-area 2025 Forecast Load and Resources

Load (MW)	Generation (MW)	Aug NQC	At Peak
The Stanislaus Sub-area does not have a defined load pocket with the limits based upon power flow through the area.	Market, Net Seller	117	117
	MUNI	94	94
	QF	0	0
	Solar	0	0
	Existing 20-minute Demand Response	0	0
	Mothballed	0	0
	Total		211

3.2.4.4.3 Stanislaus LCR Sub-area Hourly Profiles

The Stanislaus Sub-area does not have a defined load pocket with the limits based upon power flow through the area. As such, no load profile is provided for this sub-area.

3.2.4.4.4 Stanislaus LCR Sub-area Requirement

Table 3.2-19 identifies the sub-area requirements. The LCR requirement for Category P3 contingency is 213 MW including 2 MW deficiency.

Table 3.2-19 Stanislaus LCR Sub-area Requirements

Year	Limit	Category	Limiting Facility	Contingency	LCR (MW) (Deficiency)
2025	First limit	P3	Manteca – Ripon 115 kV	Bellota-Riverbank-Melones 115 kV and Stanislaus PH	213 (2)

3.2.4.4.5 Effectiveness factors:

All units within this sub-area have the same effectiveness factor.

For most helpful procurement information please read procedure 2210Z Effectiveness Factors under 7110 (T-138Z) posted at: <http://www.caiso.com/Documents/2210Z.pdf>

3.2.4.5 Tesla-Bellota Sub-area

Tesla-Bellota is a Sub-area of the Stockton LCR Area.

3.2.4.5.1 Tesla-Bellota LCR Sub-area Diagram

Figure 3.2-22 Tesla-Bellota LCR Sub-area

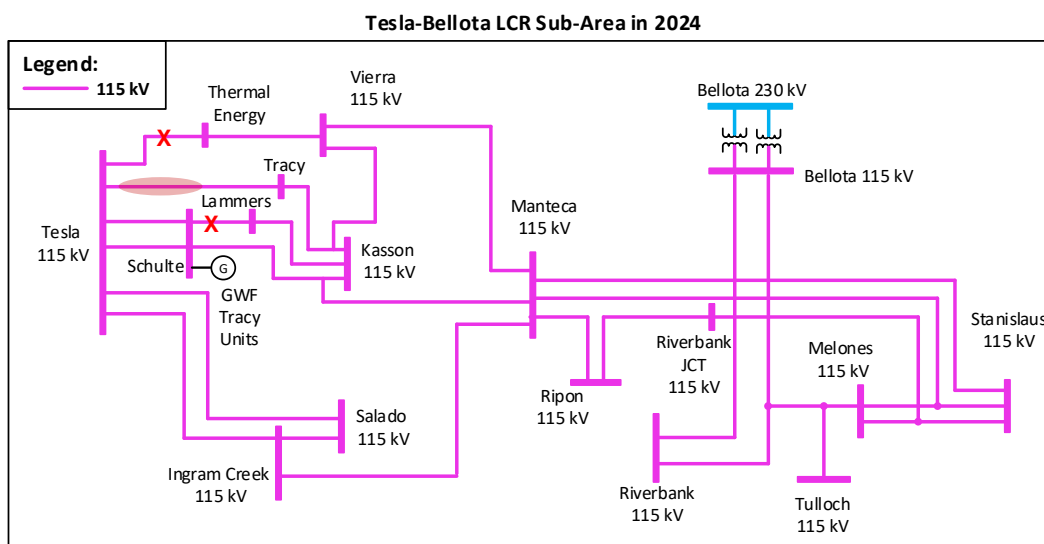

3.2.4.5.2 Tesla Bellota LCR Sub-area Load and Resources

Table 3.2-20 provides the forecasted load and resources. The list of generators within the LCR sub-area are provided in Attachment A.

Table 3.2-20 Tesla-Bellota LCR Sub-area 2025 Forecast Load and Resources

Load (MW)		Generation (MW)	Aug NQC	At Peak
Gross Load	938	Market, Net Seller	491	491
AAEE	-7	MUNI	116	116
Behind the meter DG	0	QF	0	0
Net Load	931	LTPP Preferred Resources	12	0
Transmission Losses	19	Existing 20-minute Demand Response	0	0
Pumps	0	Mothballed	0	0
Load + Losses + Pumps	950	Total	619	607

All of the resources needed to meet the Stanislaus sub-area count towards the Tesla-Bellota sub-area LCR need.

3.2.4.5.3 Tesla-Bellota LCR Sub-area Hourly Profiles

Figure 3.2-23 illustrates the forecast 2025 profile for the peak day for the Tesla-Bellota sub-area with the Category P6 normal and emergency load serving capabilities without local gas resources. The chart also includes an estimated amount of energy storage that can be added to this local area from charging restriction perspective. Figure 3.2-24 illustrates the forecast 2025 hourly profile for Tesla-Bellota sub-area with of the Category P6 emergency load serving capability without local gas resources.

Figure 3.2-23 Tesla-Bellota LCR Sub-area 2025 Peak Day Forecast Profiles

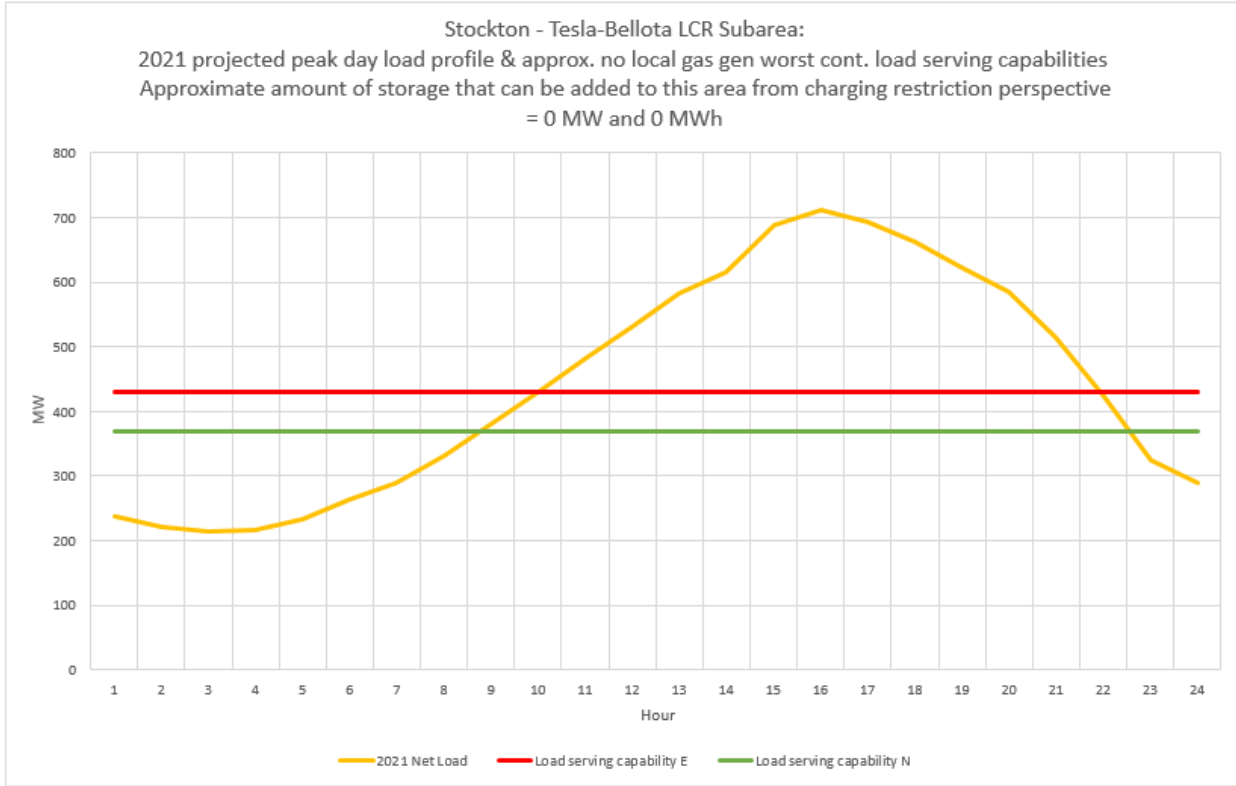
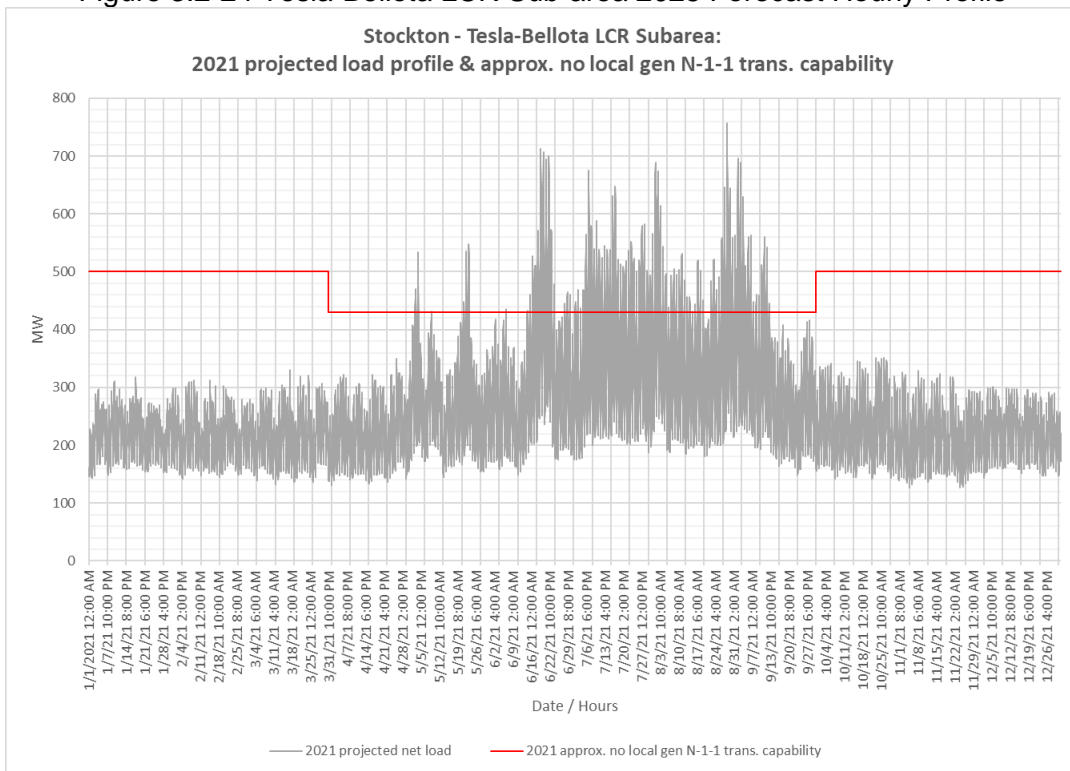

Figure 3.2-24 Tesla-Bellota LCR Sub-area 2025 Forecast Hourly Profile



3.2.4.5.4 Tesla-Bellota LCR Sub-area Requirement

Table 3.2-21 identifies the sub-area LCR requirements. The LCR requirement for Category P6 contingency is 741 MW including a 122 MW of NQC deficiency or 134 MW of at peak deficiency.

Table 3.2-21 Tesla-Bellota LCR Sub-area Requirements

Year	Limit	Category	Limiting Facility	Contingency	LCR (MW) (Deficiency)
2025	First limit	P6	Stanislaus – Melones – Riverbank Jct 115 kV	Tesla 115 kV Bus	674 (55 NQC/ 67 Peak)
2025	First limit	P6	Tesla – Vierra 115 kV	Schulte – Lammers 115 kV & Schulte-Kasson-Manteca 115 kV	431 (122 NQC/ 134 Peak)
Total LCR Need for Tesla – Bellota Sub-area in 2025					741 (122 NQC/ 134 Peak)

3.2.4.5.5 Effectiveness factors:

All units within this sub-area are needed therefore no effectiveness factor is required.

For most helpful procurement information please read procedure 2210Z Effectiveness Factors under 7110 (T-138Z) posted at: <http://www.caiso.com/Documents/2210Z.pdf>

3.2.4.6 Stockton Overall

3.2.4.6.1 Stockton LCR Area Overall Requirement

The requirement for this area is driven by the requirement for the Tesla-Bellota sub-area. Table 3.2-22 identifies the area requirements. The LCR requirement for Category P6 contingency is 741 MW with a 122 MW NQC deficiency or 134 MW at peak deficiency.

Table 3.2-22 Stockton LCR Sub-area Overall Requirements

Year	Limit	Category	Limiting Facility	Contingency	LCR (MW) (Deficiency)
2025		P6	Stockton Overall		741 (122 NQC/ 134 Peak)

3.2.4.6.2 Changes compared to 2024 LCT study

The load forecast went down by 379 MW due to the elimination of the Weber and Lockeford sub-areas, otherwise the load forecast would have gone up by 65 MW. The total LCR need has decreased by 268 MW due to transmission development and change in criteria.

3.2.5 Greater Bay Area

3.2.5.1 *Area Definition:*

The transmission tie lines into the Greater Bay Area are:

Lakeville-Sobrante 230 kV
Ignacio-Sobrante 230 kV
Parkway-Moraga 230 kV
Bahia-Moraga 230 kV
Lambie SW Sta-Vaca Dixon 230 kV
Peabody-Contra Costa P.P. 230 kV
Tesla-Kelso 230 kV
Tesla-Delta Switching Yard 230 kV
Tesla-Pittsburg #1 230 kV
Tesla-Pittsburg #2 230 kV
Tesla-Newark #1 230 kV
Tesla-Newark #2 230 kV
Tesla-Ravenswood 230 kV
Tesla-Metcalf 500 kV
Moss Landing-Metcalf 500 kV
Moss Landing-Metcalf #1 230 kV
Moss Landing-Metcalf #2 230 kV
Oakdale TID-Newark #1 115 kV
Oakdale TID-Newark #2 115 kV

The substations that delineate the Greater Bay Area are:

Lakeville is out Sobrante is in
Ignacio is out Sobrante is in
Parkway is out Moraga is in
Bahia is out Moraga is in
Lambie SW Sta is in Vaca Dixon is out
Peabody is out Contra Costa P.P. is in
Tesla is out Kelso is in
Tesla is out Delta Switching Yard is in

Tesla is out Pittsburg is in
 Tesla is out Pittsburg is in
 Tesla is out Newark is in
 Tesla is out Newark is in
 Tesla is out Ravenswood is in
 Tesla is out Metcalf is in
 Moss Landing is out Metcalf is in
 Moss Landing is out Metcalf is in
 Moss Landing is out Metcalf is in
 Oakdale TID is out Newark is in
 Oakdale TID is out Newark is in

3.2.5.1.1 Greater Bay LCR Area Diagram

Figure 3.2-25 Greater Bay LCR Area

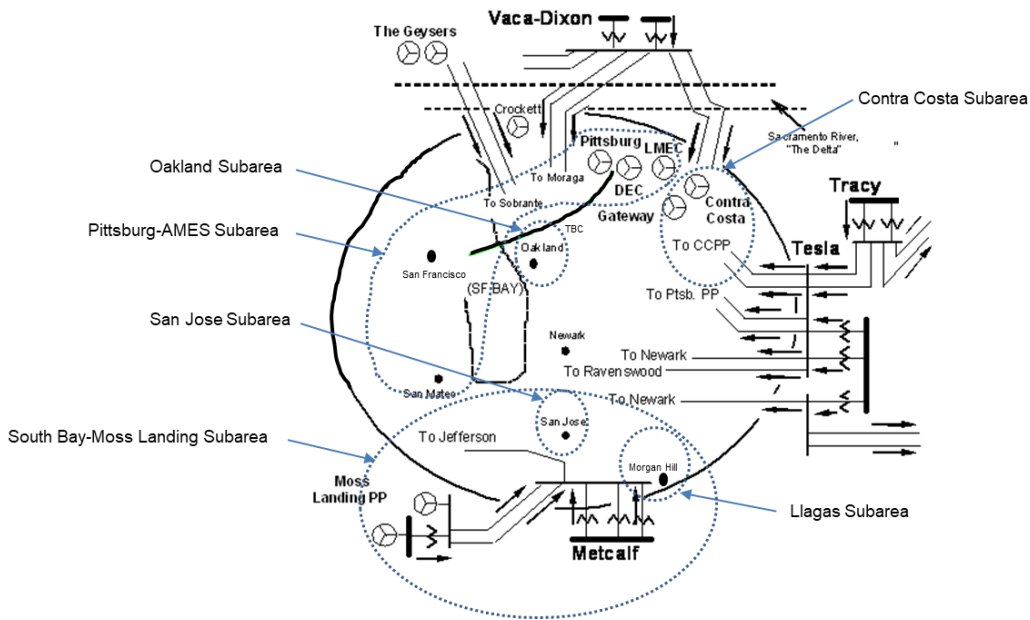

3.2.5.1.2 Greater Bay LCR Area Load and Resources

Table 3.2-23 provides the forecasted load and resources. The list of generators within the LCR area are provided in Attachment A.

In year 2025 the estimated time of local area peak is 17:50 PM.

At the local area peak time the estimated, ISO metered, solar output is 44.00%.

If required, all technology type resources, including solar, are dispatched at NQC.

Table 3.2-23 Greater Bay Area LCR Area 2025 Forecast Load and Resources

Load (MW)		Generation (MW)	Aug NQC	At Peak
Gross Load	10606	Market, Net Seller, Battery, Wind	6138	6138
AAEE	-120	MUNI	377	377
Behind the meter DG	-247	QF	227	227
Net Load	10239	Solar	8	8
Transmission Losses	240	Existing 20-minute Demand Response	0	0
Pumps	264	Future preferred resource and energy storage	594	594
Load + Losses + Pumps	10743	Total	7344	7344

3.2.5.1.3 Approved transmission projects modeled

- Oakland Clean Energy Initiative Project (Oakland CTs are assumed retired)
- Morgan Hill Area Reinforcement (revised scope)
- Metcalf-Piercy & Swift and Newark-Dixon Landing 115 kV Upgrade
- East Shore-Oakland J 115 kV Reconductoring Project
- Vaca Dixon-Lakeville 230 kV Corridor Series Compensation

3.2.5.2 Llagas Sub-area

Llagas is a Sub-area of the Greater Bay LCR Area.

3.2.5.2.1 Llagas LCR Sub-area Diagram

Figure 3.2-26 Llagas LCR Sub-area

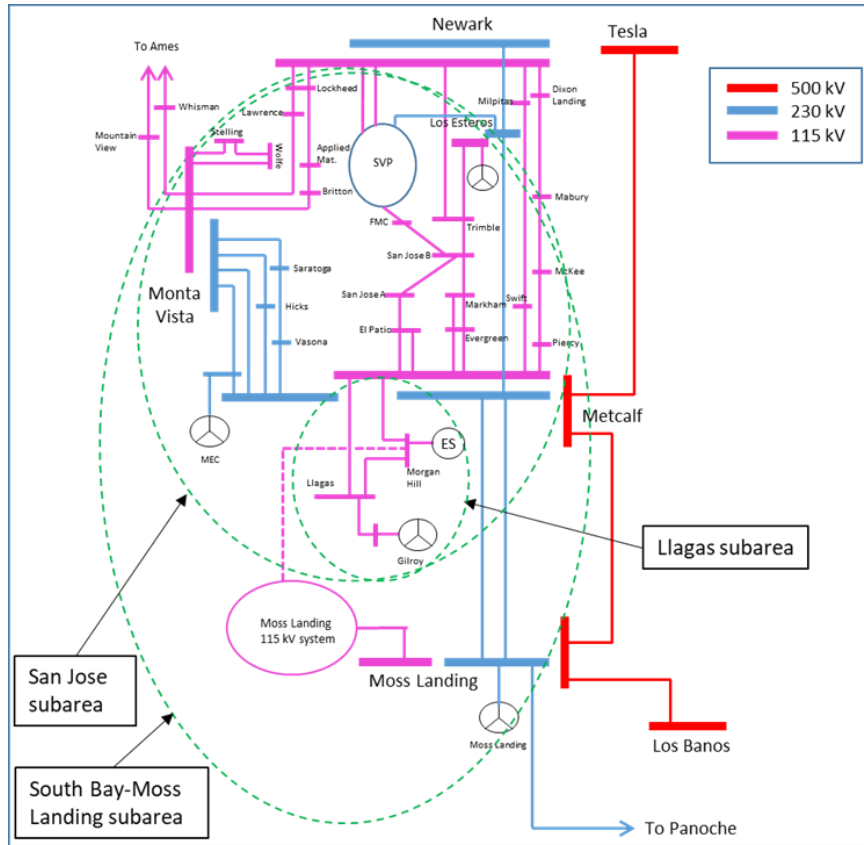

3.2.5.2.2 Llagas LCR Sub-area Load and Resources

Table 3.2-24 provides the forecasted load and resources. The list of generators within the LCR sub-area are provided in Attachment A.

Table 3.2-24 Llagas LCR Sub-area 2025 Forecast Load and Resources

Load (MW)		Generation (MW)	Aug NQC	At Peak
Gross Load	212	Market, Net Seller, Battery, Solar	246	246
AAEE	-3	MUNI	0	0
Behind the meter DG	-8	QF	0	0
Net Load	201	LTPP Preferred Resources	0	0
Transmission Losses	0	Existing 20-minute Demand Response	0	0
Pumps	0	Mothballed	0	0
Load + Losses + Pumps	201	Total	246	246

3.2.5.2.3 Llagas LCR Sub-area Hourly Profiles

Figure 3.2-27 illustrates the forecast 2025 profile for the peak day for the Llagas LCR sub-area with the Category P6 normal and emergency load serving capabilities without local gas resources. The chart also includes an estimated amount of energy storage that can be added to this local area from charging restriction perspective. Figure 3.2-28 illustrates the forecast 2025 hourly profile for Llagas LCR sub-area with the Category P6 emergency load serving capability without local gas resources.

Figure 3.2-27 Llagas LCR Sub-area 2025 Peak Day Forecast Profiles

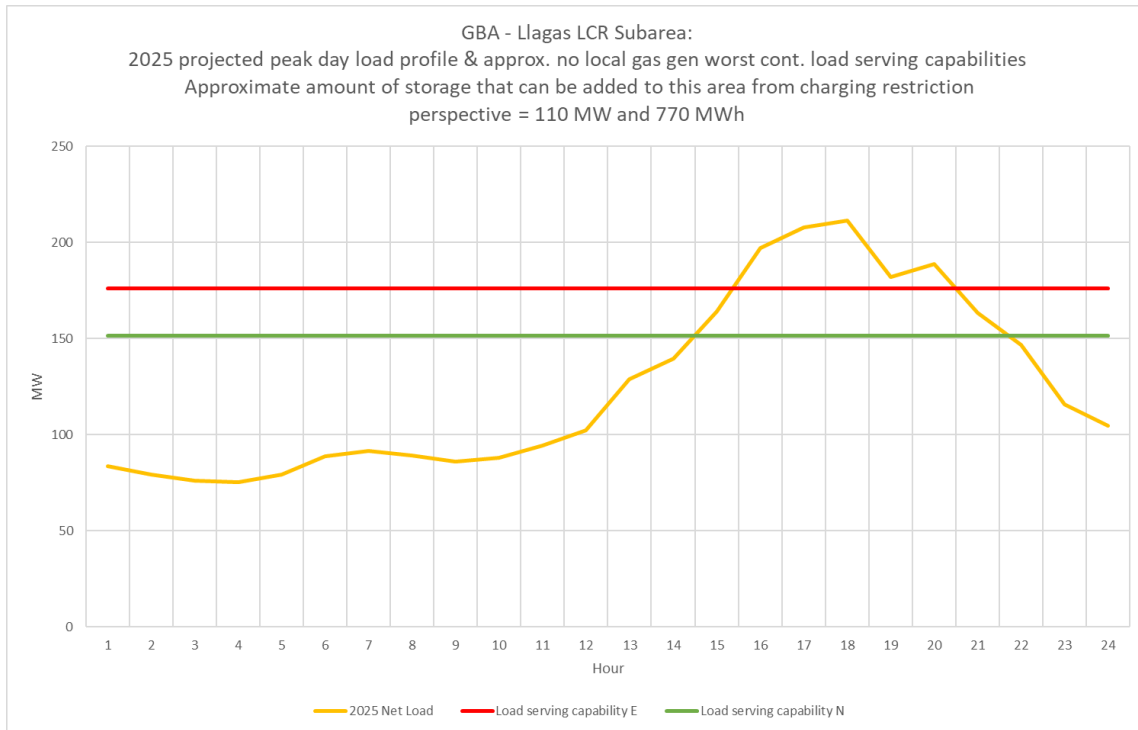
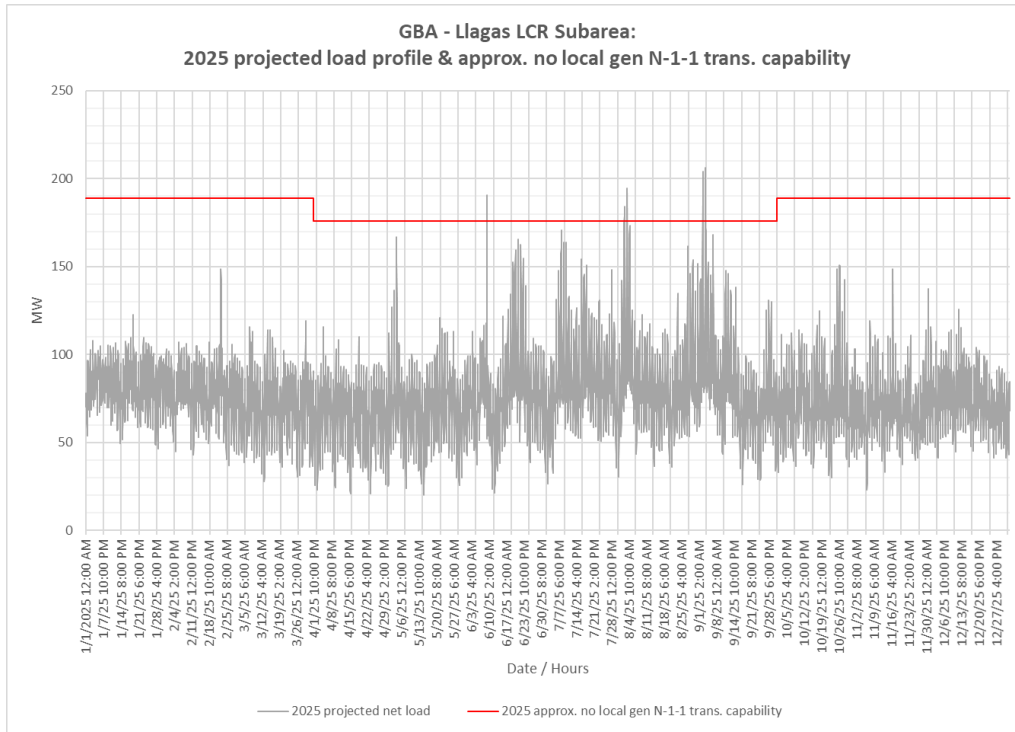

Figure 3.2-28 Llagas LCR Sub-area 2025 Forecast Hourly Profiles



3.2.5.2.4 Llagas LCR Sub-area Requirement

Table 3.2-25 identifies the sub-area LCR requirements. The LCR requirement for the Category P6 contingency is 33 MW.

Table 3.2-25 Llagas LCR Sub-area Requirements

Year	Limit	Category	Limiting Facility	Contingency	LCR (MW)
2025	First limit	P6	Metcalf-Llagas 115 kV	Metcalf-Morgan Hill 115 kV & Morgan Hill-Green Valley 115 kV	33

3.2.5.2.5 Effectiveness factors:

All units within this sub-area have the same effectiveness factor.

For most helpful procurement information please read procedure 2210Z Effectiveness Factors under 7110 (T-138Z) posted at: <http://www.caiso.com/Documents/2210Z.pdf>

3.2.5.3 San Jose Sub-area

San Jose is a Sub-area of the Greater Bay LCR Area.

3.2.5.3.1 San Jose LCR Sub-area Diagram

The San Jose LCR Sub-area is identified in Figure 3.2-25.

3.2.5.3.2 San Jose LCR Sub-area Load and Resources

Table 3.2-26 provides the forecast load and resources in San Jose LCR sub-area in 2025. The list of generators within the LCR sub-area are provided in Attachment A.

Table 3.2-26 San Jose LCR Sub-area 2025 Forecast Load and Resources

Load (MW)		Generation (MW)	Aug NQC	At Peak
Gross Load	2544	Market, Net Seller, Battery, Solar	575	575
AAEE	-32	MUNI	198	198
Behind the meter DG	-53	QF	0	0
Net Load	2459	LTPP Preferred Resources	75	75
Transmission Losses	68	Existing 20-minute Demand Response	0	0
Pumps	0	Mothballed	0	0
Load + Losses + Pumps	2527	Total	848	848

3.2.5.3.3 San Jose LCR Sub-area Hourly Profiles

Figure 3.2-29 illustrates the forecast 2025 profile for the peak day for the San Jose LCR sub-area with the Category P2 normal and emergency load serving capabilities without local gas resources. The chart also includes an estimated amount of energy storage that can be added to this local area from charging restriction perspective. Figure 3.2-30 illustrates the forecast 2025 hourly profile for San Jose LCR sub-area with the Category P2 emergency load serving capability without local gas resources.

Figure 3.2-29 San Jose LCR Sub-area 2025 Peak Day Forecast Profiles

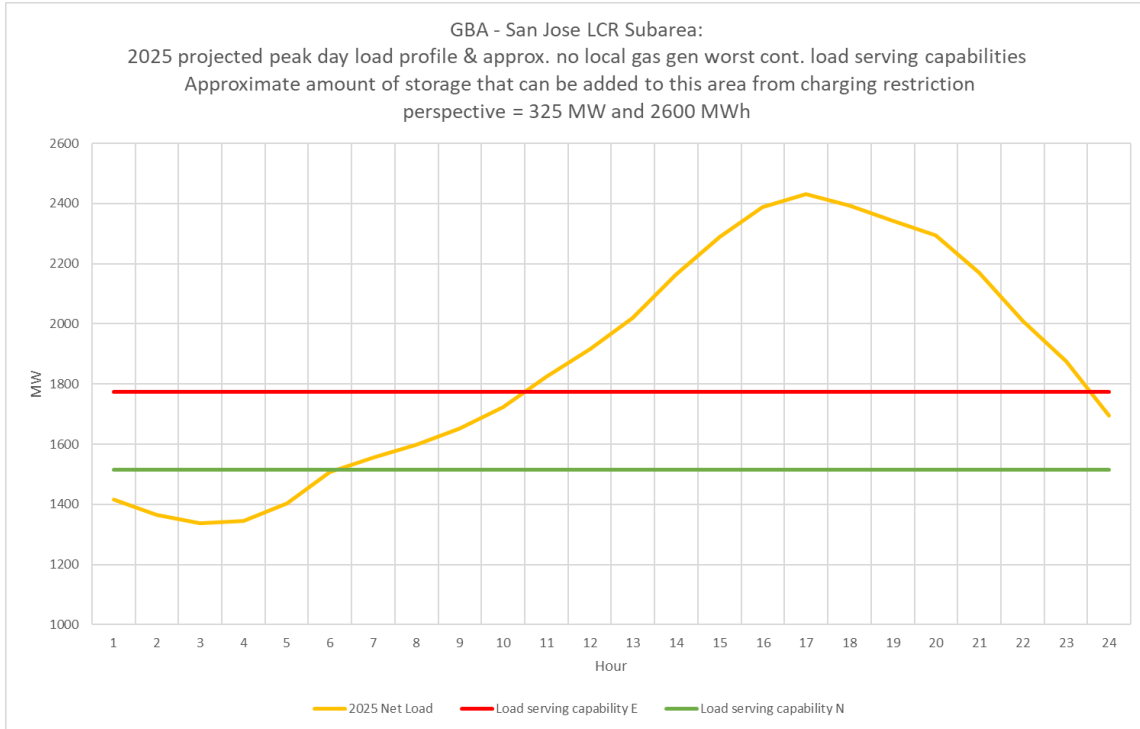
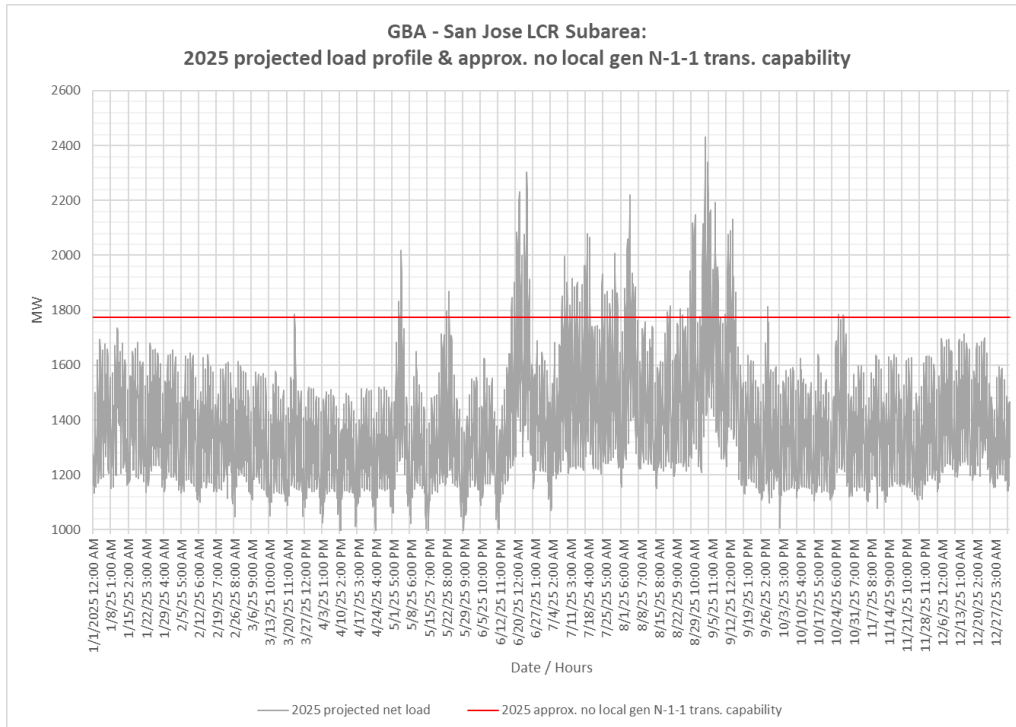

Figure 3.2-30 San Jose LCR Sub-area 2025 Forecast Hourly Profiles



3.2.5.3.4 San Jose LCR Sub-area Requirement

Table 3.2-27 identifies the sub-area LCR requirements. The LCR requirement for the Category P2 contingency is 862 MW which includes deficiency of 14 MW.

Table 3.2-27 San Jose LCR Sub-area Requirements

Year	Limit	Category	Limiting Facility	Contingency	LCR (MW) (Deficiency)
2025	First limit	P2	Metcalf 230/115 kV transformer # 1 or # 3	Metcalf 230kV - Section 2D & 2E	862 (14)

3.2.5.3.5 Effectiveness factors:

Effectiveness factors for generators in the San Jose LCR sub-area are in Attachment B table titled [San Jose](#).

For other helpful procurement information please read procedure 2210Z Effectiveness Factors under 7320 (T-165Z) posted at: <http://www.caiso.com/Documents/2210Z.pdf>

3.2.5.4 South Bay-Moss Landing Sub-area

South Bay-Moss Landing is a Sub-area of the Greater Bay LCR Area.

3.2.5.4.1 South Bay-Moss Landing LCR Sub-area Diagram

The South Bay-Moss Landing LCR sub-area is identified in Figure 3.2-26.

3.2.5.4.2 South Bay-Moss Landing LCR Sub-area Load and Resources

Table 3.2-28 provides the forecast load and resources in South Bay-Moss Landing LCR sub-area in 2025. The list of generators within the LCR sub-area are provided in Attachment A.

Table 3.2-28 South Bay-Moss Landing LCR Sub-area 2025 Forecast Load and Resources

Load (MW)		Generation (MW)	Aug NQC	At Peak
Gross Load	4165	Market, Net Seller, Battery, Solar	2165	2165
AAEE	-52	MUNI	198	198
Behind the meter DG	-101	QF	0	0
Net Load	4012	LTPP Preferred Resources	558	558
Transmission Losses	112	Existing 20-minute Demand Response	0	0
Pumps	0	Mothballed	0	0
Load + Losses + Pumps	4124	Total	2921	2921

3.2.5.4.3 South Bay-Moss Landing LCR Sub-area Hourly Profiles

Figure 3.2-31 illustrates the forecast 2025 profile for the peak day for the South Bay-Moss Landing LCR sub-area with the Category P6 normal and emergency load serving capabilities without local

gas resources. The chart also includes an estimated amount of energy storage that can be added to this local area from charging restriction perspective. The energy storage amount is incremental to the existing system and doesn't include approved energy storage. Figure 3.2-32 illustrates the forecast 2025 hourly profile for South Bay-Moss Landing LCR sub-area with the Category P6 emergency load serving capability without local gas resources.

Figure 3.2-31 South Bay-Moss Landing LCR Sub-area 2025 Peak Day Forecast Profiles

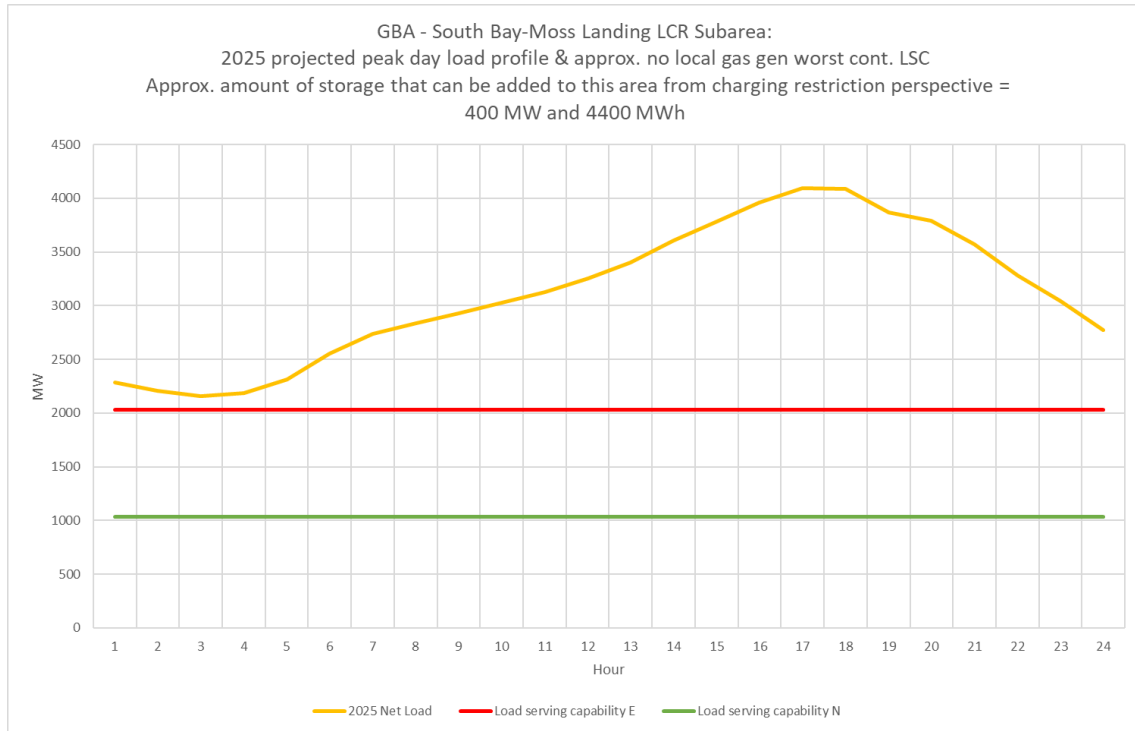
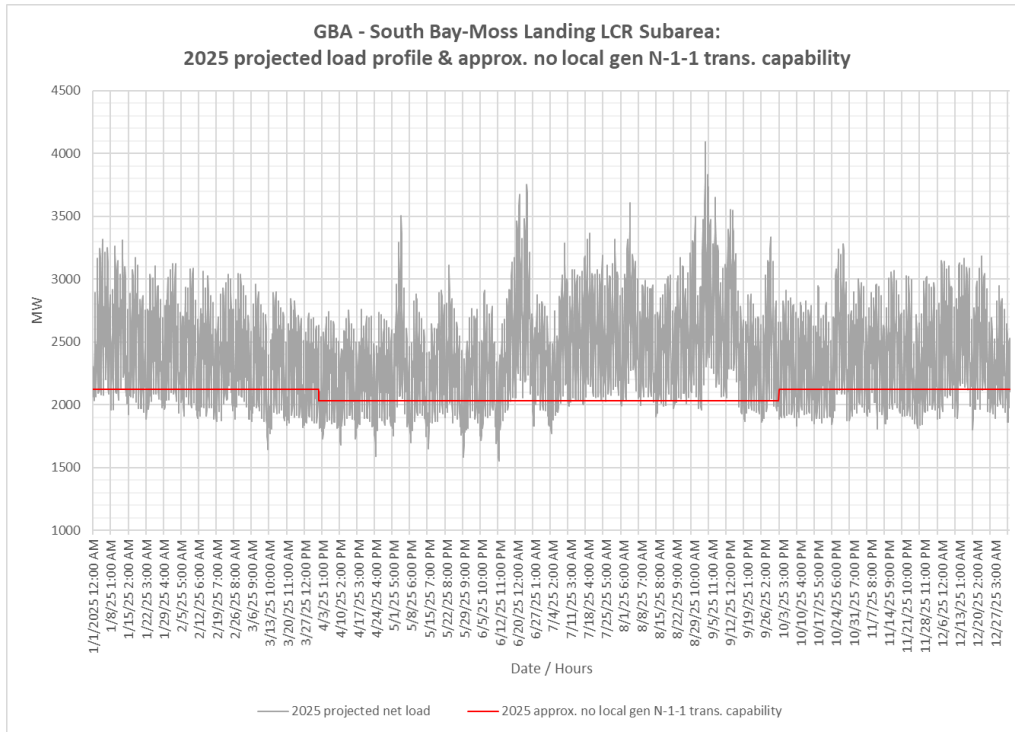

Figure 3.2-32 South Bay-Moss Landing LCR Sub-area 2025 Forecast Hourly Profiles



3.2.5.4.4 South Bay-Moss Landing LCR Sub- Requirement

Table 3.2-29 identifies the sub-area LCR requirements. The LCR requirement for the Category P6 contingency is 1784 MW.

Table 3.2-29 South Bay-Moss Landing LCR Sub-area Requirements

Year	Limit	Category	Limiting Facility	Contingency	LCR (MW)
2025	First Limit	P6	Moss Landing-Las Aguilas 230 kV	Tesla-Metcalf 500 kV and Moss Landing-Los Banos 500 kV	1784

3.2.5.4.5 Effectiveness factors:

Effectiveness factors for generators in the South Bay-Moss Landing LCR sub-area are in Attachment B table titled [South Bay-Moss Landing](#).

For other helpful procurement information please read procedure 2210Z Effectiveness Factors under 7320 (T-165Z) posted at: <http://www.caiso.com/Documents/2210Z.pdf>

3.2.5.5 Oakland Sub-area

Oakland is a Sub-area of the Greater Bay LCR Area.

3.2.5.5.1 Oakland LCR Sub-area Diagram

Figure 3.2-33 Oakland LCR Sub-area

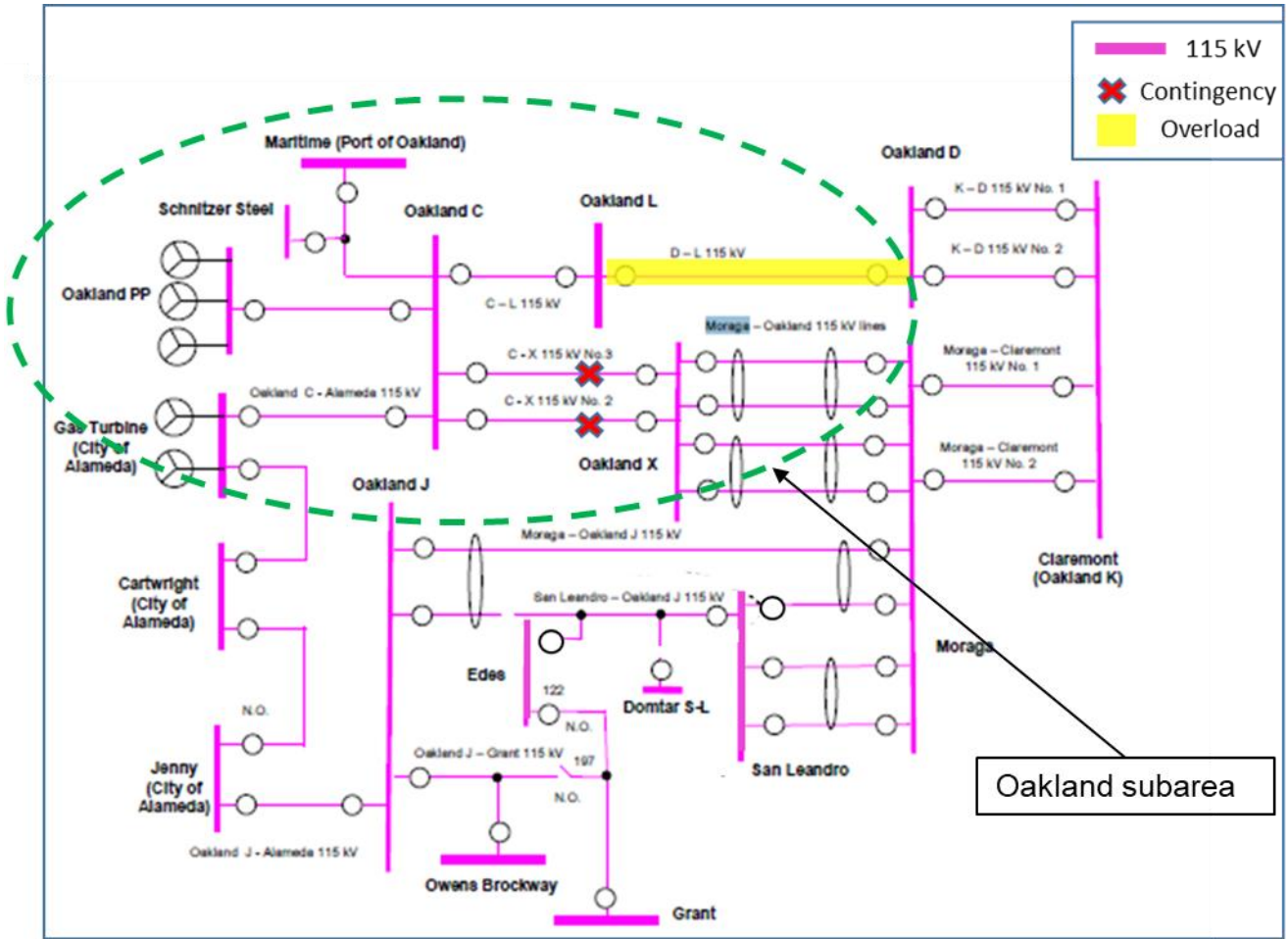

3.2.5.5.2 Oakland LCR Sub-area Load and Resources

Table 3.2-30 provides the forecast load and resources in Oakland LCR sub-area in 2025. The list of generators within the LCR sub-area are provided in Attachment A.

Table 3.2-30 Oakland LCR Sub-area 2025 Forecast Load and Resources

Load (MW)		Generation (MW)	Aug NQC	At Peak
Gross Load	225	Market, Net Seller, Battery, Solar	0	0
AAEE	-3	MUNI	48	48
Behind the meter DG	-3	QF	0	0
Net Load	219	LTPP Preferred Resources	36	36
Transmission Losses	0	Existing 20-minute Demand Response	0	0
Pumps	0	Mothballed	0	0

Load + Losses + Pumps	219	Total	84	84
-----------------------	-----	-------	----	----

3.2.5.5.3 Oakland LCR Sub-area Hourly Profiles

Figure 3.2-34 illustrates the forecast 2025 profile for the peak day for the Oakland LCR sub-area with the Category P6 normal and emergency load serving capabilities without local gas resources. The chart also includes an estimated amount of energy storage that can be added to this local area from charging restriction perspective. Figure 3.2-35 illustrates the forecast 2025 hourly profile for Oakland LCR sub-area with the Category P6 emergency load serving capability without local gas resources.

Figure 3.2-34 Oakland LCR Sub-area 2025 Peak Day Forecast Profiles

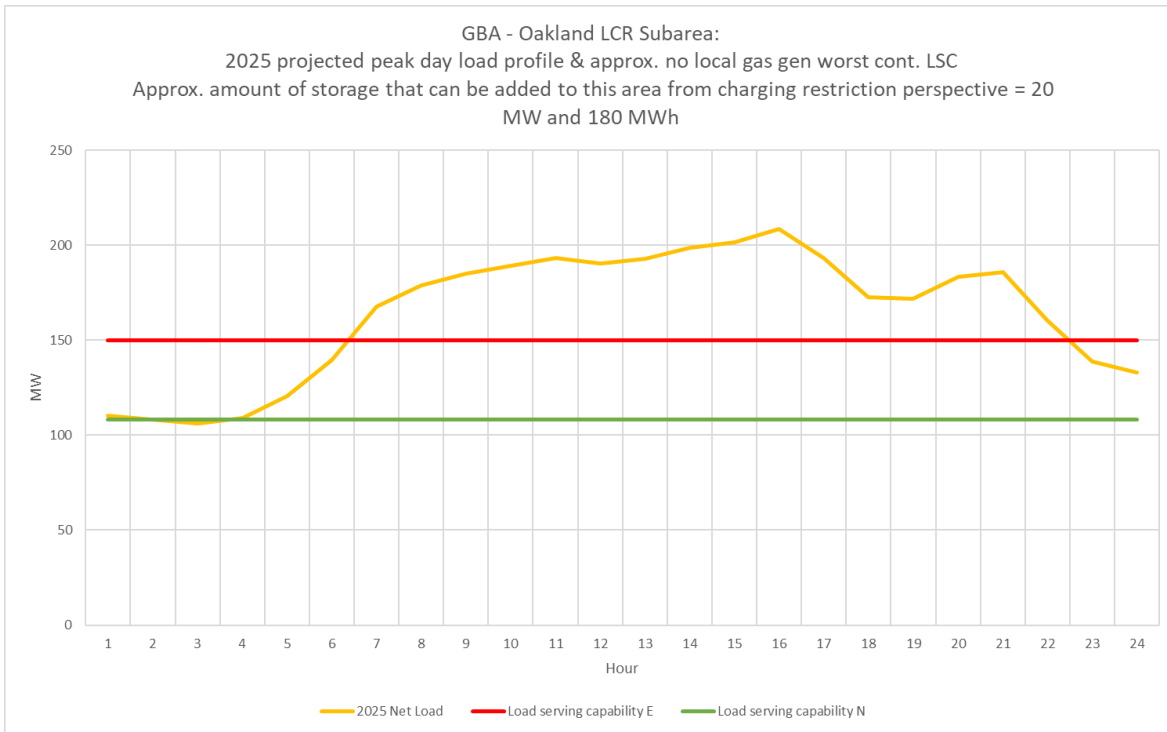
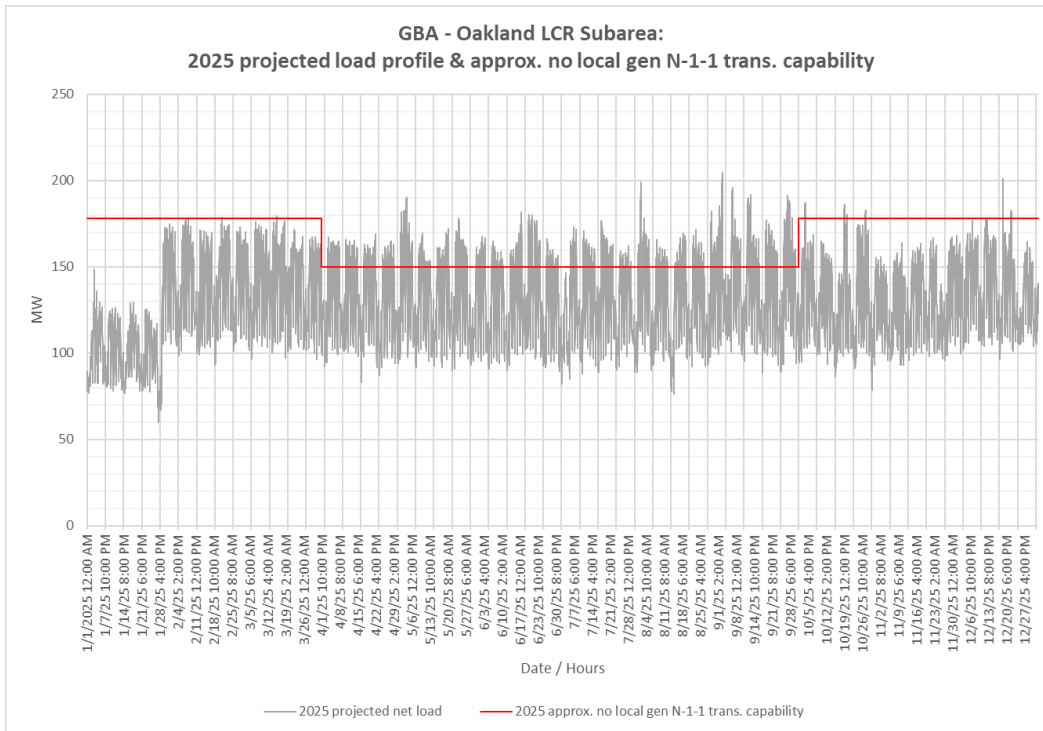

Figure 3.2-35 Oakland LCR Sub-area 2025 Forecast Hourly Profiles



3.2.5.5.4 Oakland LCR Sub-area Requirement

Table 3.2-31 identifies the sub-area requirements. The LCR requirement for the Category P6 contingency is 71 MW.

Table 3.2-31 Oakland LCR Sub-area Requirements

Year	Limit	Category	Limiting Facility	Contingency	LCR (MW)
2025	First limit	P6	Moraga-Claremont #2 115 kV cable	Oakland C-X #2 & #3 115 kV	71 ⁵

3.2.5.5.5 Effectiveness factors:

All units within the Oakland sub-area have the same effectiveness factor.

For most helpful procurement information please read procedure 2210Z Effectiveness Factors under 7110 (T-138Z) posted at: <http://www.caiso.com/Documents/2210Z.pdf>

⁵ This requirement doesn't reflect potential load transfer that could occur following the first contingency. An approved operating procedure including this load transfer could reduce this requirement.

3.2.5.6 Ames-Pittsburg-Oakland Sub-areas Combined

Ames-Pittsburg-Oakland is a Sub-area of the Greater Bay LCR Area.

3.2.5.6.1 Ames-Pittsburg-Oakland LCR Sub-area Diagram

Figure 3.2-36 Ames-Pittsburg-Oakland LCR Sub-area

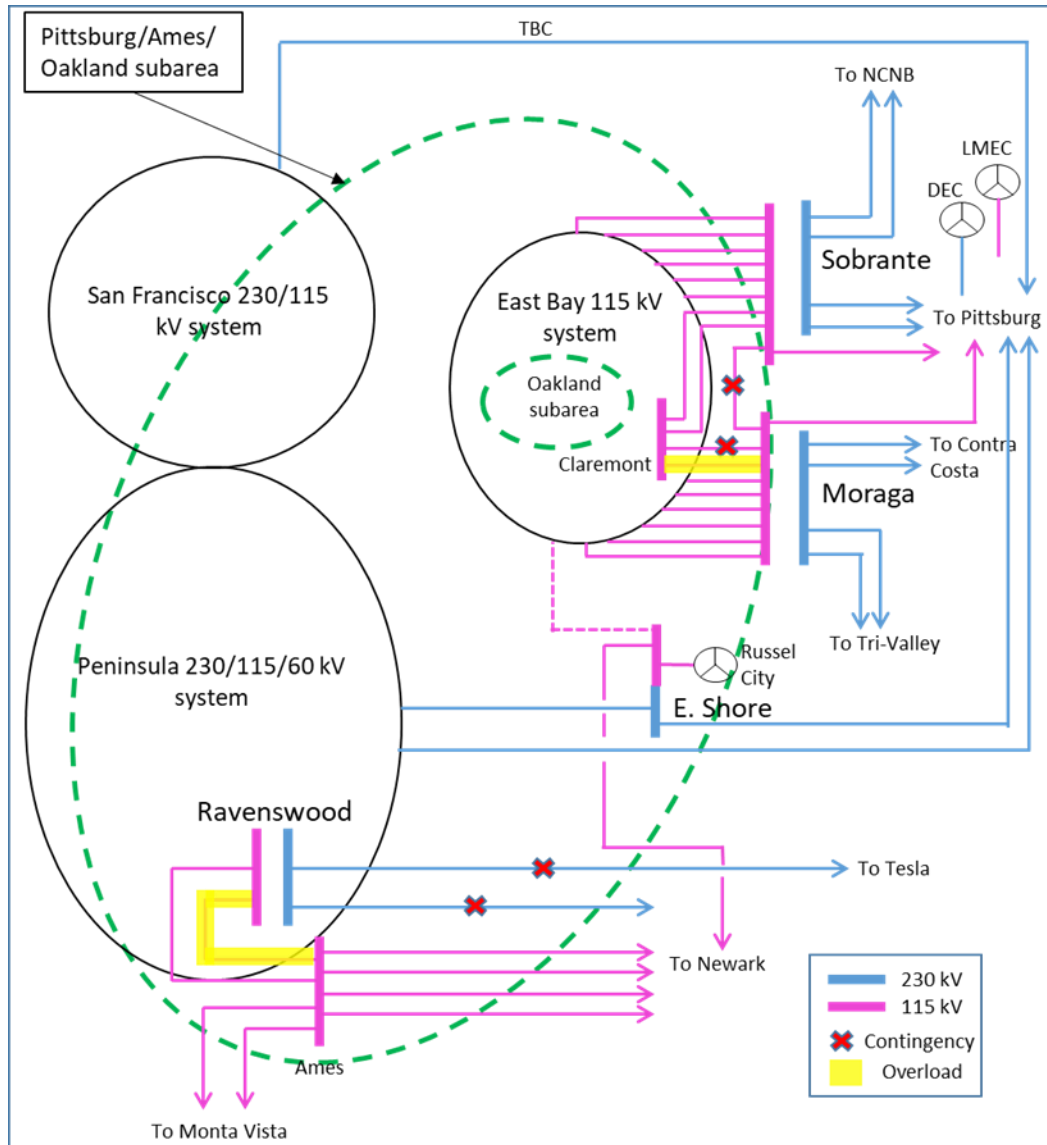

3.2.5.6.2 Ames-Pittsburg-Oakland LCR Sub-area Load and Resources

Table 3.2-32 provides the forecast load and resources in Ames-Pittsburg-Oakland LCR sub-area in 2025. The list of generators within the LCR sub-area are provided in Attachment A.

Table 3.2-32 Ames-Pittsburg-Oakland LCR Sub-area 2025 Forecast Load and Resources

Load (MW)	Generation (MW)	Aug NQC	At Peak
-----------	-----------------	---------	---------

The Ames-Pittsburg-Oakland Sub-area does not has a defined load pocket with the limits based upon power flow through the area.	Market, Net Seller, Battery, Wind	2152	2152
	MUNI	48	48
	QF	225	225
	Solar	5	5
	Existing 20-minute Demand Response	0	0
	LTPP Preferred Resources	36	36
	Total	2466	2466

3.2.5.6.3 Ames-Pittsburg-Oakland LCR Sub-area Hourly Profiles

The Ames-Pittsburg-Oakland Sub-area does not has a defined load pocket with the limits based upon power flow through the area. As such, no load profile is provided for this sub-area.

3.2.5.6.4 Ames-Pittsburg-Oakland LCR Sub-area Requirement

Table 3.2-33 identifies the sub-area LCR requirements. The LCR requirement for the Category P7 or P2 contingency is 1761 MW.

Table 3.2-33 Ames-Pittsburg-Oakland LCR Sub-area Requirements

Year	Limit	Category	Limiting Facility	Contingency	LCR (MW)
2025	First limit	P7	Ames-Ravenswood #1 115 kV line	Newark-Ravenswood 230 kV & Tesla-Ravenswood 230 kV	1761
		P2	Martinez-Sobrante 115 kV line	Pittsburg Section 1D & 1E 230kV	

3.2.5.6.5 Effectiveness factors:

Effectiveness factors for generators in the Ames-Pittsburg-Oakland LCR sub-area are in Attachment B table titled [Ames/Pittsburg/Oakland](#).

For other helpful procurement information please read procedure 2210Z Effectiveness Factors under 7320 (T-165Z) posted at: <http://www.caiso.com/Documents/2210Z.pdf>

3.2.5.7 Contra Costa Sub-area

Contra Costa is a Sub-area of the Greater Bay LCR Area.

3.2.5.7.1 Contra Costa LCR Sub-area Diagram

Figure 3.2-37 Contra Costa LCR Sub-area

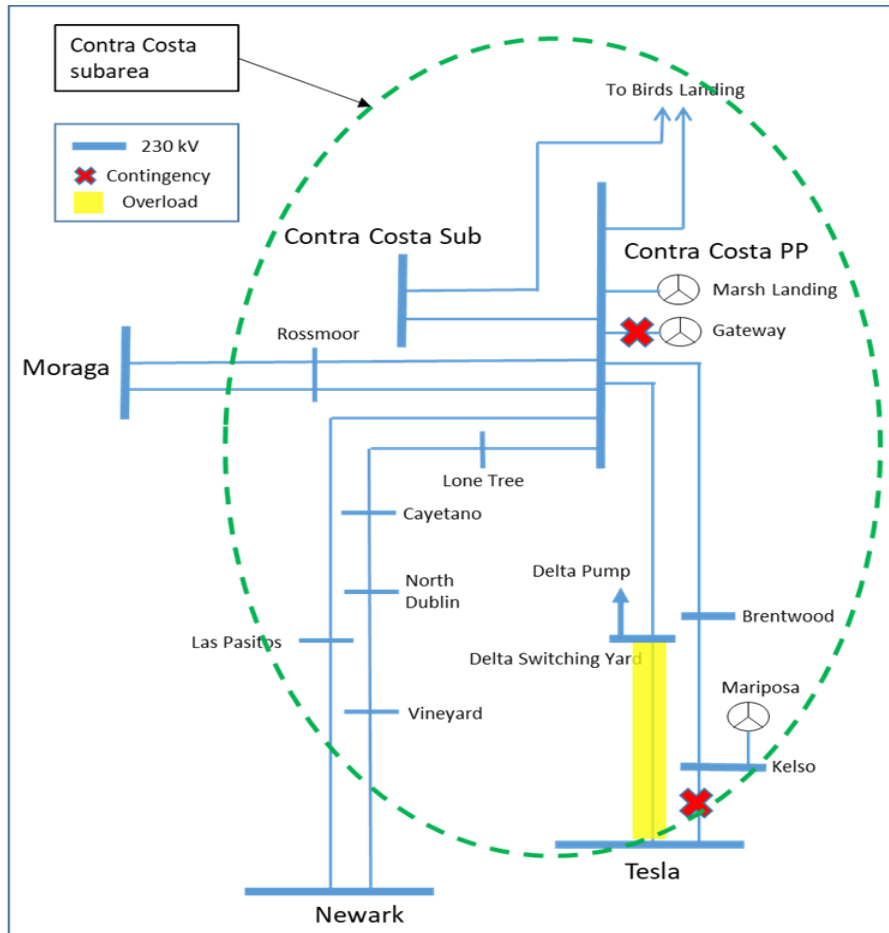

3.2.5.7.2 Contra Costa LCR Sub-area Load and Resources

Table 3.2-34 provides the forecast load and resources in Contra Costa LCR sub-area in 2025. The list of generators within the LCR sub-area are provided in Attachment A.

Table 3.2-34 Contra Costa LCR Sub-area 2025 Forecast Load and Resources

Load (MW)	Generation (MW)	Aug NQC	At Peak
The Contra Costa Sub-area does not has a defined load pocket with the limits based upon power flow through the area.	Market, Net Seller, Battery, Solar	1669	1669
	MUNI	127	127
	QF	0	0
	Wind	244	244
	Existing 20-minute Demand Response	0	0
	Mothballed	0	0
	Total	2040	2040

3.2.5.7.3 Contra Costa LCR Sub-area Hourly Profiles

The Contra Costa Sub-area does not has a defined load pocket with the limits based upon power flow through the area. As such, no load profile is provided for this sub-area.

3.2.5.7.4 Contra Costa LCR Sub-area Requirement

Table 3.2-35 identifies the sub-area LCR requirements. The LCR requirement for the Category P6 contingency is 1417 MW.

Table 3.2-35 Contra Costa LCR Sub-area Requirements

Year	Limit	Category	Limiting Facility	Contingency	LCR (MW)
2025	First limit	P3	Delta Switching Yard-Tesla 230 kV	Kelso-Tesla 230 kV line and Gateway unit	1417

3.2.5.7.5 Effectiveness factors:

For other helpful procurement information please read procedure 2210Z Effectiveness Factors under 7230 (T-165Z) posted at: <http://www.caiso.com/Documents/2210Z.pdf>

3.2.5.8 Bay Area overall

3.2.5.8.1 Greater Bay LCR Area Overall Requirement

Table 3.2-36 identifies the area LCR requirements. The LCR requirement for the Category P6 contingency is 6110 MW.

Table 3.2-36 Bay Area LCR Overall area Requirements

Year	Limit	Category	Limiting Facility	Contingency	LCR (MW)
2025	First limit	P6	Metcalf 500/230 kV #13 transformer	Metcalf 500/230 kV #11 & #12 transformers	6110

3.2.5.8.2 Changes compared to 2024 requirements

Load forecast went up by 316 MW and total LCR need went up by 1715 MW mainly due to the new LCR criteria.

3.2.6 Greater Fresno Area

3.2.6.1 *Area Definition:*

The transmission facilities coming into the Greater Fresno area are:

- Gates-Mustang #1 230 kV
- Gates-Mustang #2 230 kV
- Gates #5 230/70 kV Transformer Bank
- Mercy Spring 230 /70 Bank # 1
- Los Banos #3 230/70 Transformer Bank
- Los Banos #4 230/70 Transformer Bank
- Warnerville-Wilson 230kV
- Melones-North Merced 230 kV line
- Panoche-Tranquility #1 230 kV
- Panoche-Tranquility #2 230 kV
- Panoche #1 230/115 kV Transformer Bank
- Panoche #2 230/115 kV Transformer Bank
- Corcoran-Smyrna 115kV
- Coalinga #1-San Miguel 70 kV

The substations that delineate the Greater Fresno area are:

- Gates is out Mustang is in
- Gates is out Mustang is in
- Gates 230 is out Gates 70 is in
- Mercy Springs 230 is out Mercy Springs 70 is in
- Los Banos 230 is out Los Banos 70 is in
- Los Banos 230 is out Los Banos 70 is in
- Warnerville is out Wilson is in
- Melones is out North Merced is in
- Panoche is out Tranquility #1 is in
- Panoche is out Tranquility #2 is in
- Panoche 230 is out Panoche 115 is in
- Panoche 230 is out Panoche 115 is in
- Corcoran is in Smyrna is out

Coalinga is in San Miguel is out

3.2.6.1.2 Fresno LCR Area Diagram

Figure 3.2-38 Fresno LCR Area

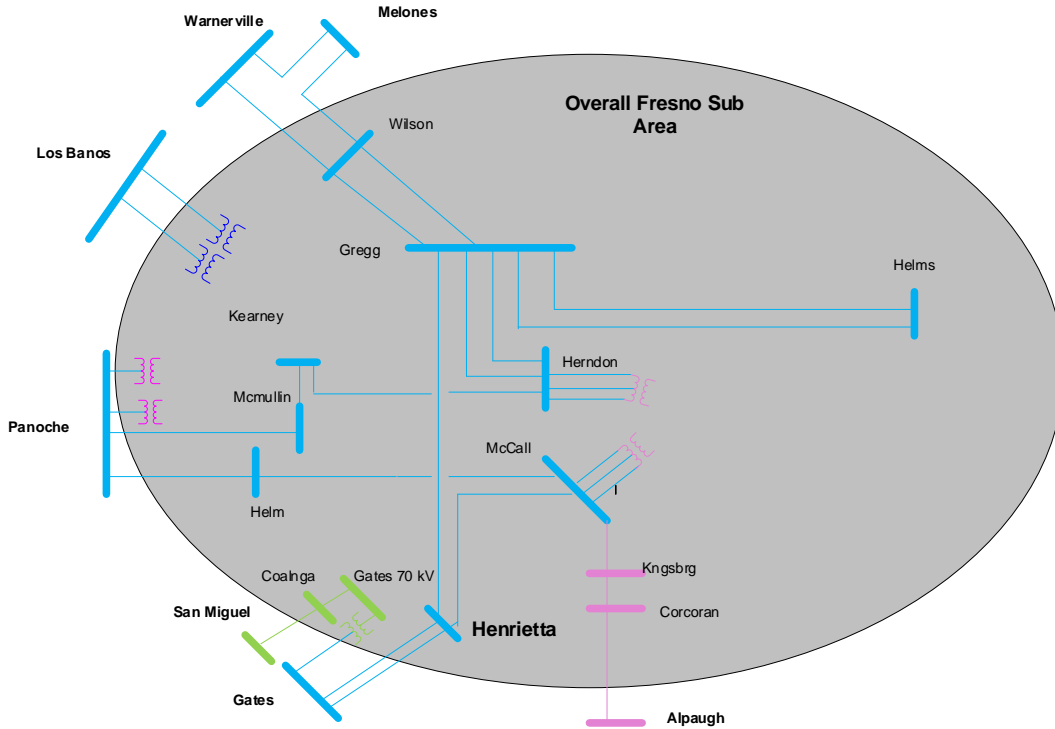

3.2.6.1.3 Fresno LCR Area Load and Resources

Table 3.2-37 provides the forecast load and resources in Fresno LCR Area in 2025. The list of generators within the LCR sub-area are provided in Attachment A.

In year 2025 the estimated time of local area peak is 18:40 PM.

At the local area peak time the estimated, ISO metered, solar output is 12.00%.

If required, all non-solar technology type resources are dispatched at NQC.

Table 3.2-37 Fresno LCR Area 2025 Forecast Load and Resources

Load (MW)		Generation (MW)	Aug NQC	At Peak
Gross Load	3217	Market, Net Seller, Battery	2815	2815
AAEE	-26	MUNI	212	212
Behind the meter DG	-5	QF	4	4

Net Load	3186	Solar	361	160
Transmission Losses	93	Existing 20-minute Demand Response	0	0
Pumps	0	Mothballed	0	0
Load + Losses + Pumps	3279	Total	3392	3191

3.2.6.1.4 Approved transmission projects modeled

- Northern Fresno 115 kV Reinforcement (Revised scope – Mar 2021)
- Gregg-Herndon #2 230 kV Line Circuit Breaker Upgrade (Jan 2021)
- Wilson-Legrand 115 kV Reconductoring (Apr 2020)
- Panoche-Oro Loma 115 kV Reconductoring (Apr 2021)
- Oro Loma 70 kV Reinforcement (May 2020)
- Reedley 70 kV Reinforcement Projects (Dec 2021)
- Herndon-Bullard Reconductoring Projects (Jan 2021)
- Wilson 115 kV Area Reinforcement (May 2023)
- Bellota-Warnerville 230 kV Line Reconductoring (Dec 2023)

3.2.6.2 Hanford Sub-area

Hanford is a Sub-area of the Fresno LCR Area.

3.2.6.2.1 Hanford LCR Sub-area Diagram

Figure 3.2-39 Hanford LCR Sub-area

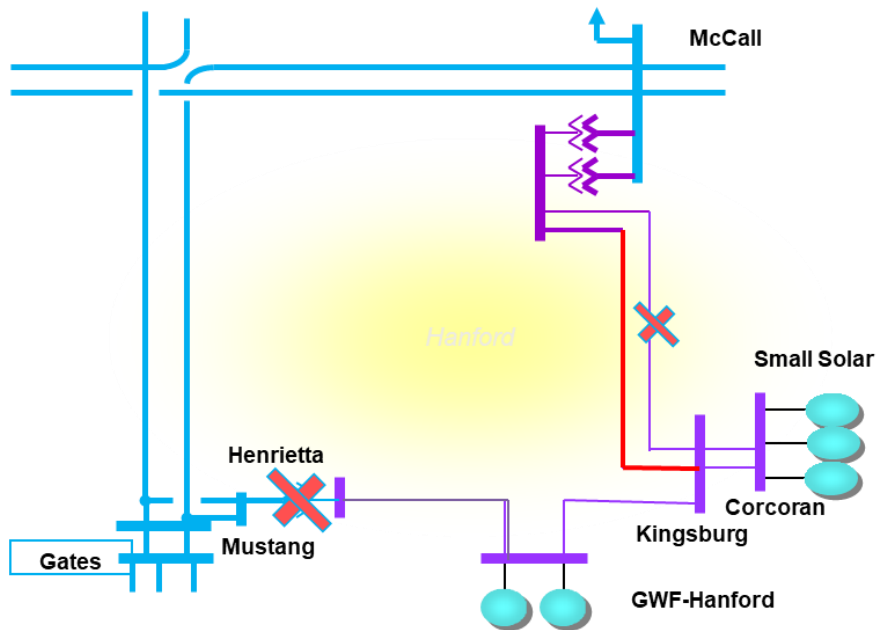

3.2.6.2.2 Hanford LCR Sub-area Load and Resources

Table 3.2-38 provides the forecast load and resources in Hanford LCR sub-area in 2025. The list of generators within the LCR sub-area are provided in Attachment A.

Table 3.2-38 Hanford LCR Sub-area 2025 Forecast Load and Resources

Load (MW)		Generation (MW)	Aug NQC	At Peak
Gross Load	209	Market, Net Seller, Battery	125	125
AAEE	-1	MUNI	0	0
Behind the meter DG	-3	QF	0	0
Net Load	205	Solar	25	11
Transmission Losses	5	Existing 20-minute Demand Response	0	0
Pumps	0	Mothballed	0	0
Load + Losses + Pumps	210	Total	150	136

3.2.6.2.3 Hanford LCR Sub-area Hourly Profiles

Figure 3.2-40 illustrates the forecast 2025 profile for the peak day for the Hanford LCR sub-area with the Category P6 normal and emergency load serving capabilities without local gas resources. The chart also includes an estimated amount of energy storage that can be added to this local area from charging restriction perspective. The energy storage amount is incremental to the existing system and doesn't include approved energy storage. Figure 3.2-41 illustrates the forecast 2025 hourly profile for Hanford LCR sub-area with the Category P6 emergency load serving capability without local gas resources.

Figure 3.2-40 Hanford LCR Sub-area 2025 Peak Day Forecast Profiles

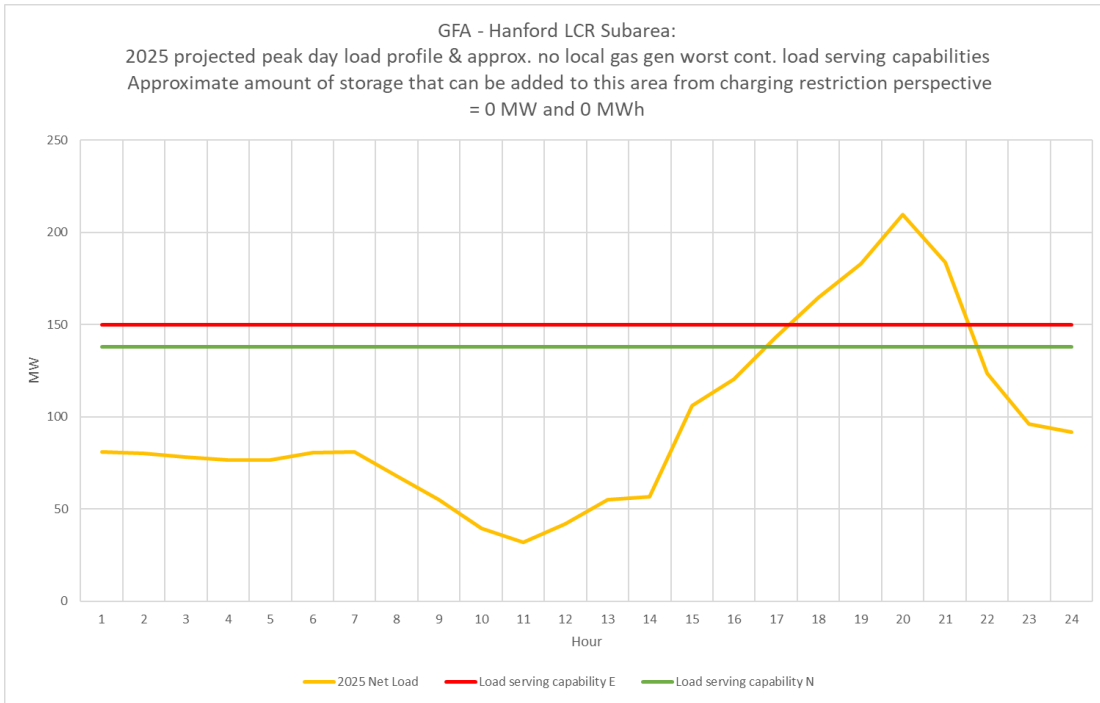
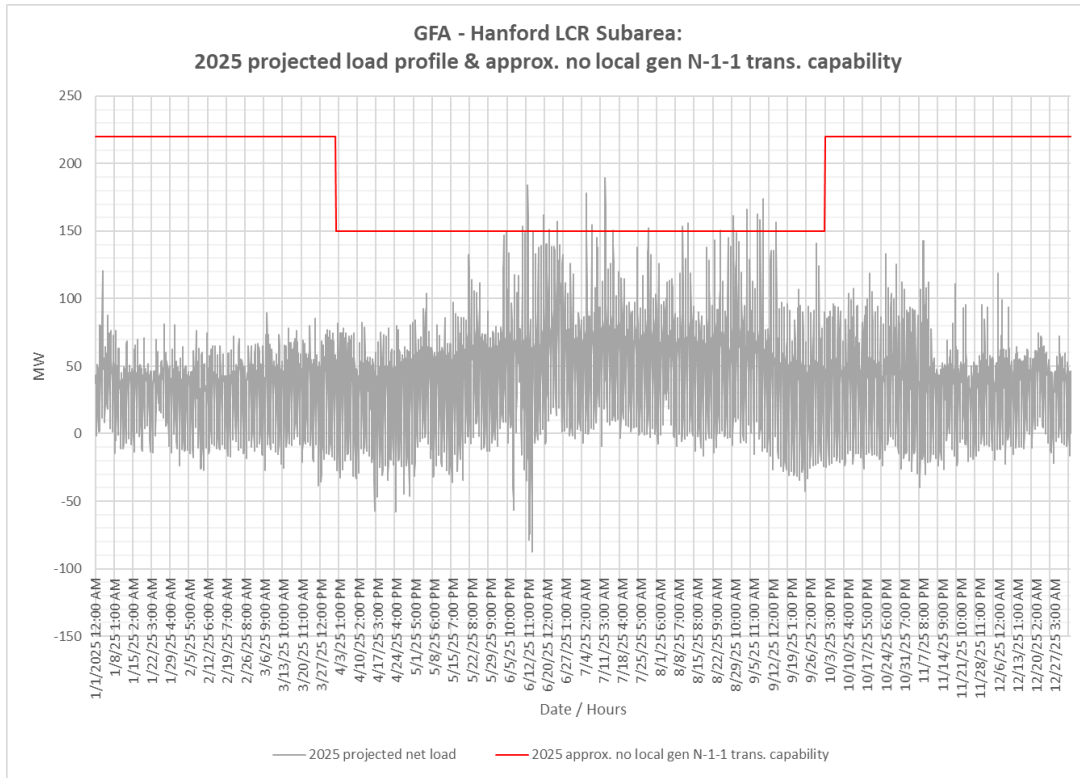

Figure 3.2-41 Hanford LCR Sub-area 2025 Forecast Hourly Profiles



3.2.6.2.4 Hanford LCR Sub-area Requirement

Table 3.2-39 identifies the sub-area requirements. The LCR Requirement for a Category P6 contingency is 58 MW.

Table 3.2-39 Hanford LCR Sub-area Requirements

Year	Limit	Category	Limiting Facility	Contingency	LCR (MW) (Deficiency)
2025	First Limit	P6	McCall-Kingsburg #2 115 kV	McCall-Kingsburg #1 115kV line and Henrietta 230/115kV TB#3	58

3.2.6.2.5 Effectiveness factors:

All units within the Hanford sub-area have the same effectiveness factor.

For most helpful procurement information please read procedure 2210Z Effectiveness Factors under 7110 (T-138Z) posted at: <http://www.caiso.com/Documents/2210Z.pdf>

3.2.6.3 Coalinga Sub-area

Coalinga is a Sub-area of the Fresno LCR Area.

3.2.6.3.1 Coalinga LCR Sub-area Diagram

Figure 3.2-42 Coalinga LCR Sub-area

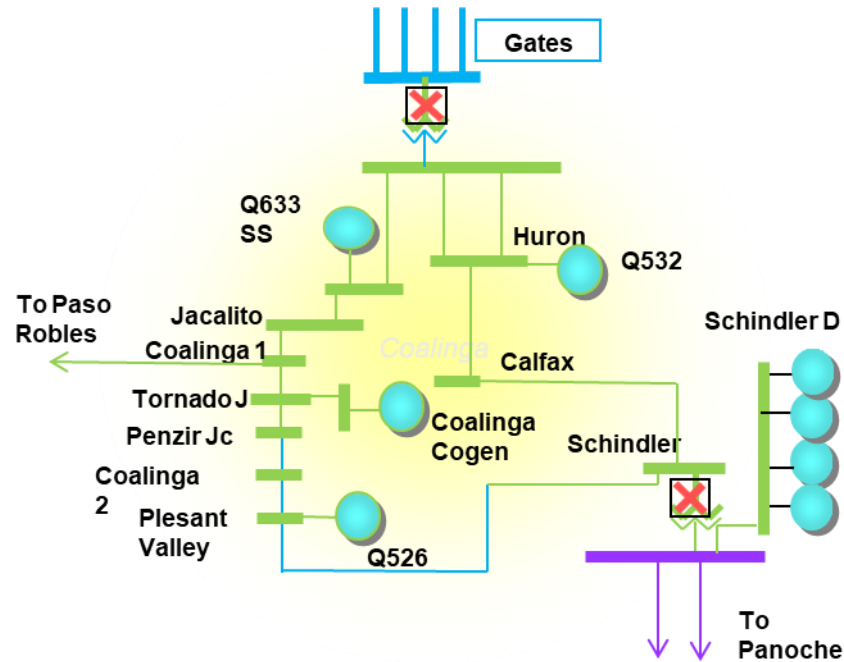

3.2.6.3.2 Coalinga LCR Sub-area Load and Resources

Table 3.2-40 provides the forecast load and resources in Coalinga LCR sub-area in 2025. The list of generators within the LCR sub-area are provided in Attachment A.

Table 3.2-40 Coalinga LCR Sub-area 2025 Forecast Load and Resources

Load (MW)		Generation (MW)	Aug NQC	At Peak
Gross Load	89	Market, Net Seller, Battery	0	0
AAEE	-1	MUNI	0	0
Behind the meter DG	0	QF	3	3
Net Load	88	Solar	13	6
Transmission Losses	1	Existing 20-minute Demand Response	0	0
Pumps	0	Mothballed	0	0
Load + Losses + Pumps	89	Total	16	9

3.2.6.3.3 Coalinga LCR Sub-area Hourly Profiles

Figure 3.2-43 illustrates the forecast 2025 profile for the peak day for the Coalinga LCR sub-area with the Category P6 normal and emergency load serving capabilities without local gas resources. The chart also includes an estimated amount of energy storage that can be added to this local area from charging restriction perspective. The energy storage amount is incremental to the existing system and doesn't include approved energy storage. Figure 3.2-44 illustrates the

forecast 2025 hourly profile for Coalinga LCR sub-area with the Category P6 emergency load serving capability without local gas resources.

Figure 3.2-43 Coalinga LCR Sub-area 2025 Peak Day Forecast Profiles

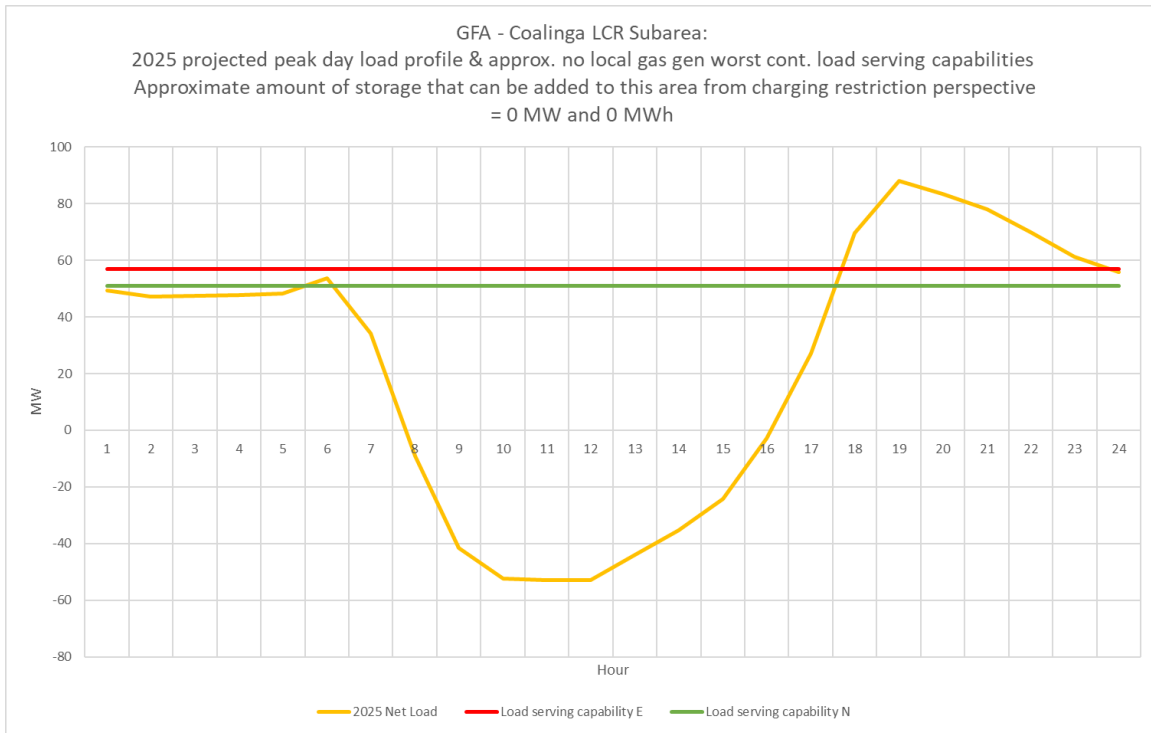
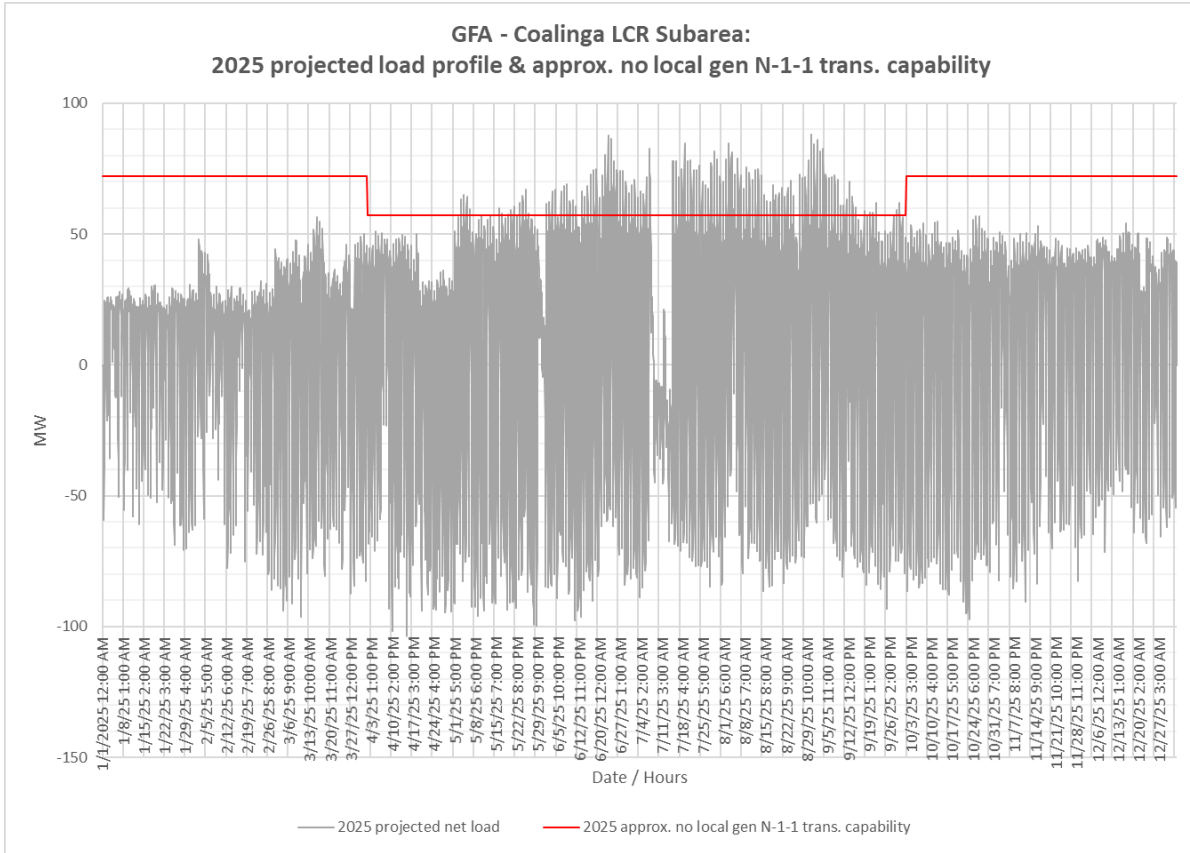

Figure 3.2-44 Coalinga LCR Sub-area 2025 Forecast Hourly Profiles



3.2.6.3.4 Coalinga LCR Sub-area Requirement

Table 3.2-41 identifies the sub-area requirements. The LCR Requirement for a Category P6 contingency is 52 MW including a 43 MW at peak deficiency and 36 MW NQC deficiency.

Table 3.2-41 Coalinga LCR Sub-area Requirements

Year	Limit	Category	Limiting Facility	Contingency	LCR (MW) (Deficiency)
2025	First Limit	P6	Overload on San-Miguel-Coalinga 70kV Line and Voltage Instability	T-1/T-1: Gates 230/70kV TB #5 and Schindler 115/70 kV TB#1	52 (43 Peak) (36 NQC)

3.2.6.3.5 Effectiveness factors:

All units within the Coalinga sub-area have the same effectiveness factor.

For most helpful procurement information please read procedure 2210Z Effectiveness Factors under 7110 (T-138Z) posted at: <http://www.caiso.com/Documents/2210Z.pdf>

3.2.6.4 Borden Sub-area

Borden is a sub-area of the Fresno LCR Area.

3.2.6.4.1 Borden LCR Sub-area Diagram

Figure 3.2-45 Borden LCR Sub-area

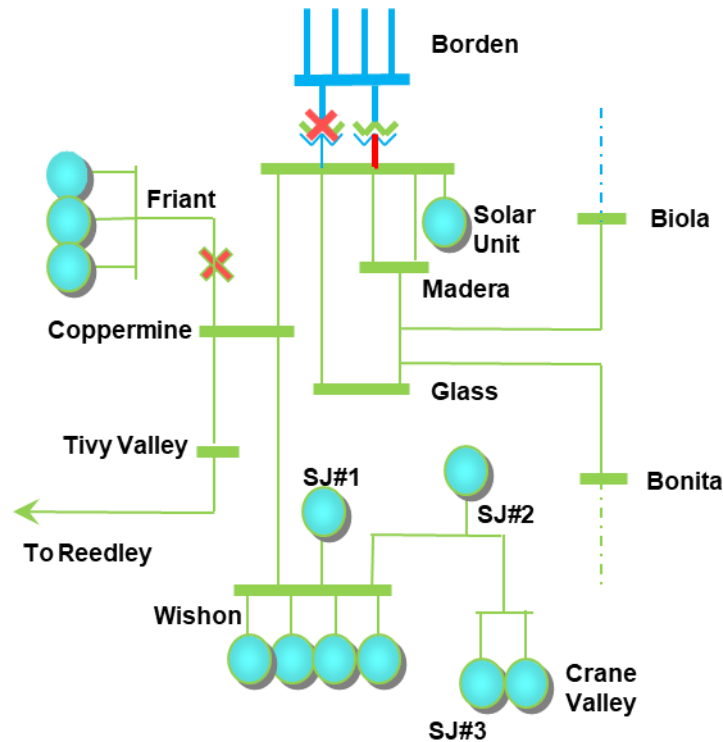

3.2.6.4.2 Borden LCR Sub-area Load and Resources

Table 3.2-42 provides the forecast load and resources in Borden LCR sub-area in 2025. The list of generators within the LCR sub-area are provided in Attachment A.

Table 3.2-42 Borden LCR Sub-area 2025 Forecast Load and Resources

Load (MW)		Generation (MW)	Aug NQC	At Peak
Gross Load	136	Market, Net Seller, Battery	33	33
AAEE	-1	MUNI	0	0
Behind the meter DG	0	QF	0	0
Net Load	135	Solar	13	6
Transmission Losses	2	Existing 20-minute Demand Response	0	0
Pumps	0	Mothballed	0	0
Load + Losses + Pumps	137	Total	46	39

3.2.6.4.3 Borden LCR Sub-area Hourly Profiles

Figure 3.2-46 illustrates the forecast 2025 profile for the peak day for the Borden LCR sub-area with the Category P6 normal and emergency load serving capabilities without local gas resources. The chart also includes an estimated amount of energy storage that can be added to this local area from charging restriction perspective. The energy storage amount is incremental to the existing system and doesn't include approved energy storage. Figure 3.2-47 illustrates the forecast 2025 hourly profile for Borden LCR sub-area with the Category P6 emergency load serving capability without local gas resources.

Figure 3.2-46 Borden LCR Sub-area 2025 Peak Day Forecast Profiles

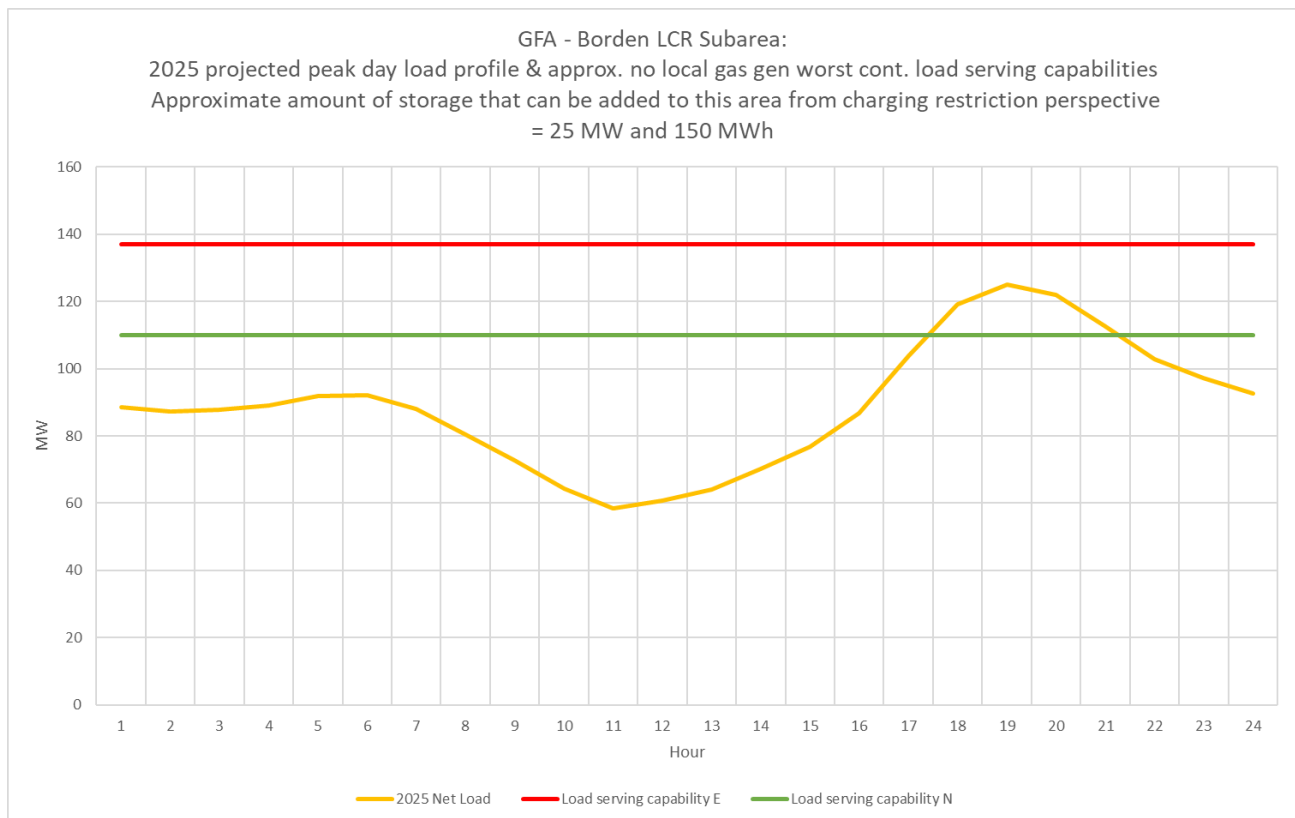
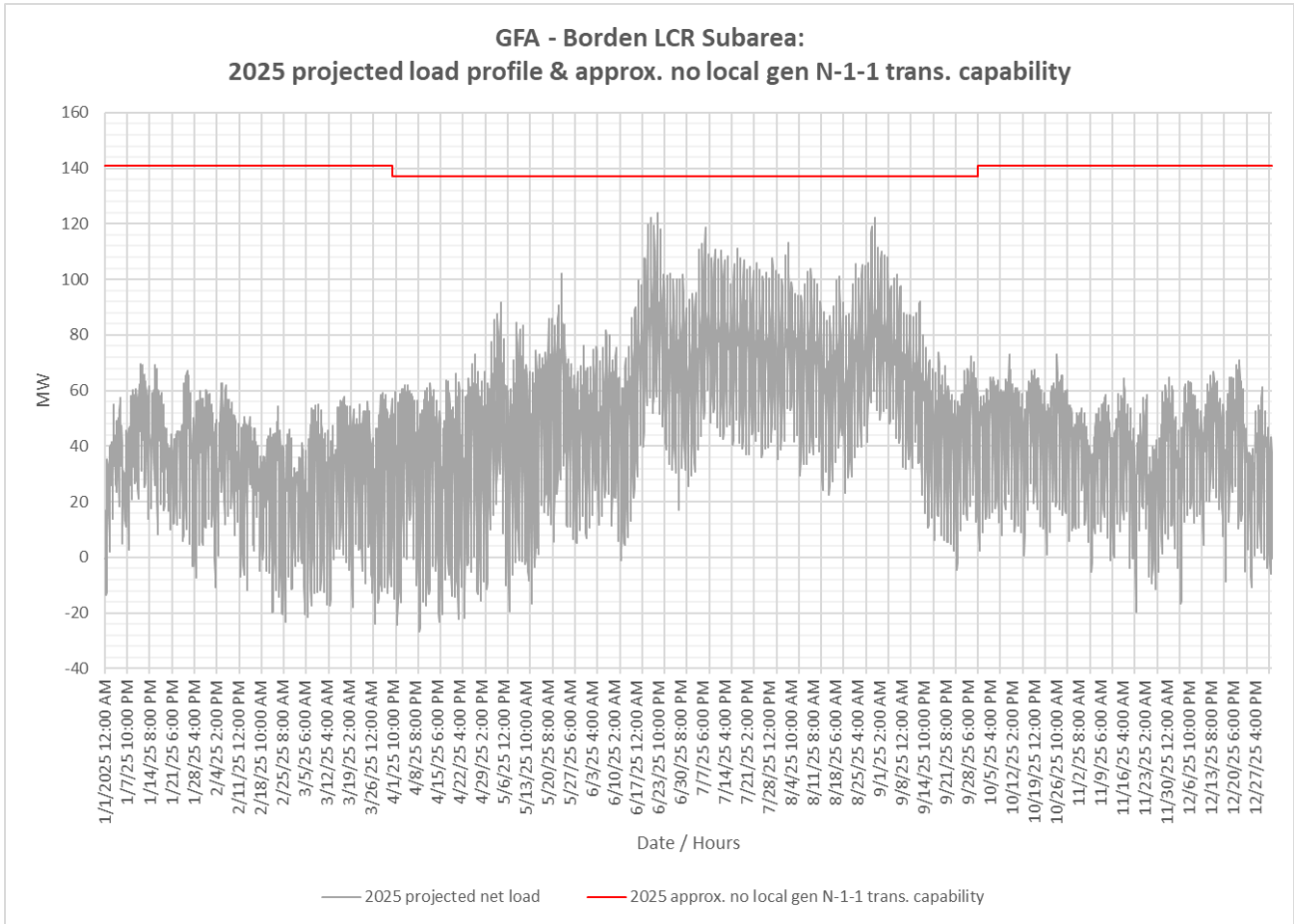

Figure 3.2-47 Borden LCR Sub-area 2025 Forecast Hourly Profiles



3.2.6.4.4 Borden LCR Sub-area Requirement

Table 3.2-43 identifies the sub-area LCR requirements. The LCR requirement for Category P6 contingency is 4 MW.

Table 3.2-43 Borden LCR Sub-area Requirements

Year	Limit	Category	Limiting Facility	Contingency	LCR (MW) (Deficiency)
2025	First Limit	P6	Borden #1 230/70 kV Tx	Friant - Coppermine 70 kV & Borden #2 230/70 kV Tx	4

3.2.6.4.5 Effectiveness factors:

All units within the Borden sub-area have the same effectiveness factor.

For most helpful procurement information please read procedure 2210Z Effectiveness Factors under 7110 (T-138Z) posted at: <http://www.caiso.com/Documents/2210Z.pdf>

3.2.6.5 Reedley Sub-area

Reedley is a Sub-area of the Fresno LCR Area.

3.2.6.5.1 Reedley LCR Sub-area Diagram

Figure 3.2-48 Reedley LCR Sub-area

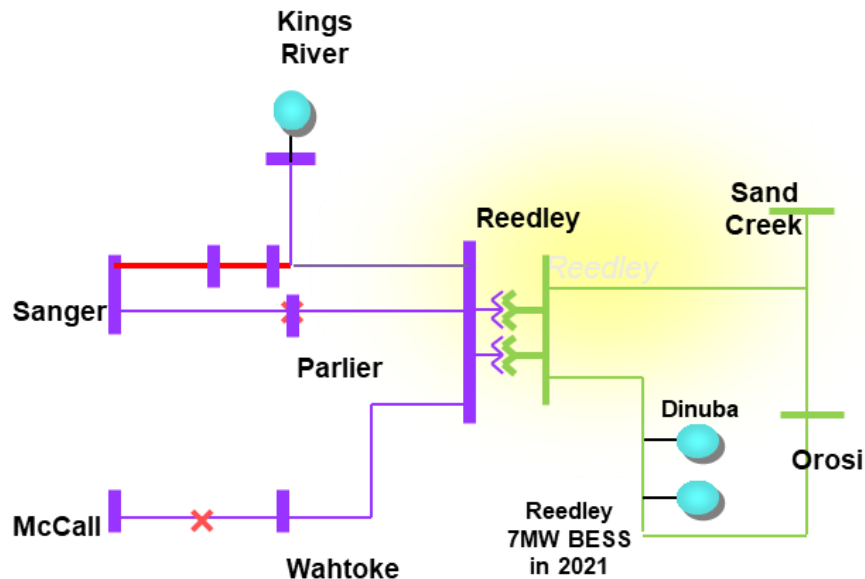

3.2.6.5.2 Reedley LCR Sub-area Load and Resources

Table 3.2-44 provides the forecast load and resources in Reedley LCR sub-area in 2025. The list of generators within the LCR sub-area are provided in Attachment A.

Table 3.2-44 Reedley LCR Sub-area 2024 Forecast Load and Resources

Load (MW)		Generation (MW)		Aug NQC	At Peak
Gross Load	223	Market		51	51
AAEE	-8	MUNI		0	0
Behind the meter DG	0	QF		0	0
Net Load	215	LTPP Preferred Resources		0	0
Transmission Losses	50	Existing 20-minute Demand Response		0	0
Pumps	0	Mothballed		0	0
Load + Losses + Pumps	265	Total		51	51

3.2.6.5.3 Reedley LCR Sub-area Hourly Profiles

Figure 3.2-49 illustrates the forecast 2025 profile for the peak day for the Reedley LCR sub-area with the Category P6 normal and emergency load serving capabilities without local gas resources. The chart also includes an estimated amount of energy storage that can be added to this local area from charging restriction perspective. The energy storage amount is incremental to the existing system and doesn't include approved energy storage. Figure 3.2-50 illustrates the forecast 2025 hourly profile for Reedley LCR sub-area with the Category P6 emergency load serving capability without local gas resources.

Figure 3.2-49 Reedley LCR Sub-area 2025 Peak Day Forecast Profiles

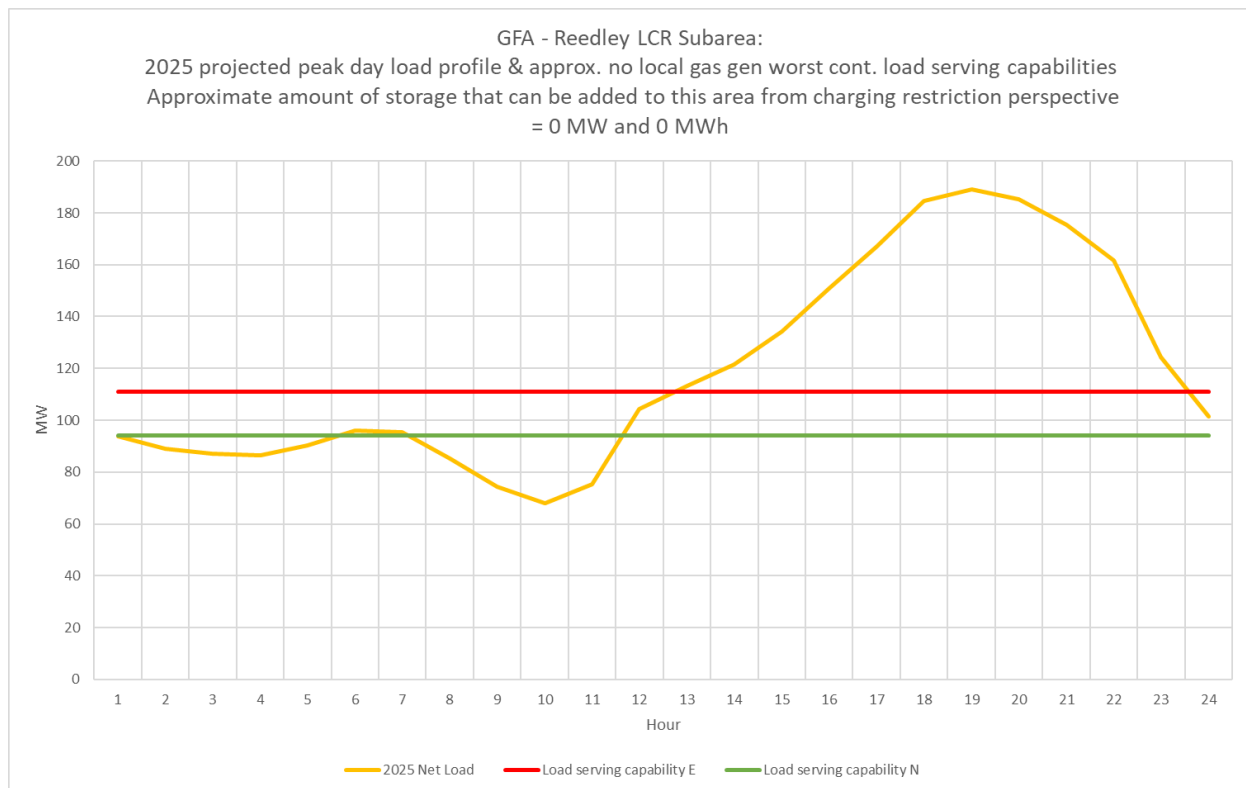
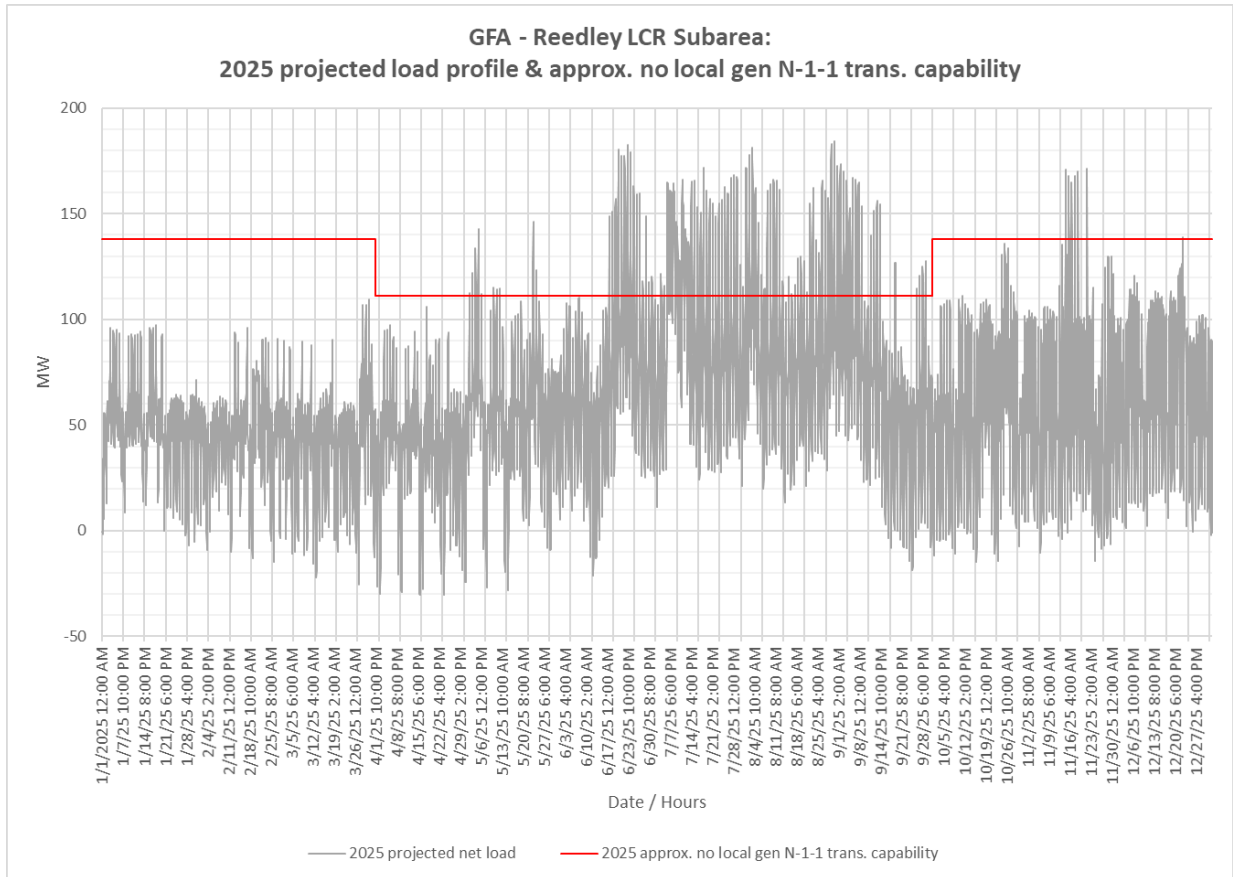

Figure 3.2-50 Reedley LCR Sub-area 2025 Forecast Hourly Profiles



3.2.6.5.4 Reedley LCR Sub-area Requirement

Table 3.2-45 identifies the sub-area requirements. The LCR Requirement for a Category P6 contingency is 84 MW including a 33 MW of deficiency.

Table 3.2-45 Reedley LCR Sub-area Requirements

Year	Limit	Category	Limiting Facility	Contingency	LCR (MW) (Deficiency)
2025	First Limit	P6	Kings River-Sanger-Reedley 115 kV	McCall-Reedley 115 kV & Sanger-Reedley 115 kV	84 (33)

3.2.6.5.5 Effectiveness factors:

All units within the Reedley Sub-area have the same effectiveness factor.

For most helpful procurement information please read procedure 2210Z Effectiveness Factors under 7110 (T-138Z) posted at: <http://www.caiso.com/Documents/2210Z.pdf>

3.2.6.6 Panoche Sub-area

Panoche is a Sub-area of the Fresno LCR Area.

3.2.6.6.1 Panoche LCR Sub-area Diagram

Figure 3.2-51 Panoche LCR Sub-area

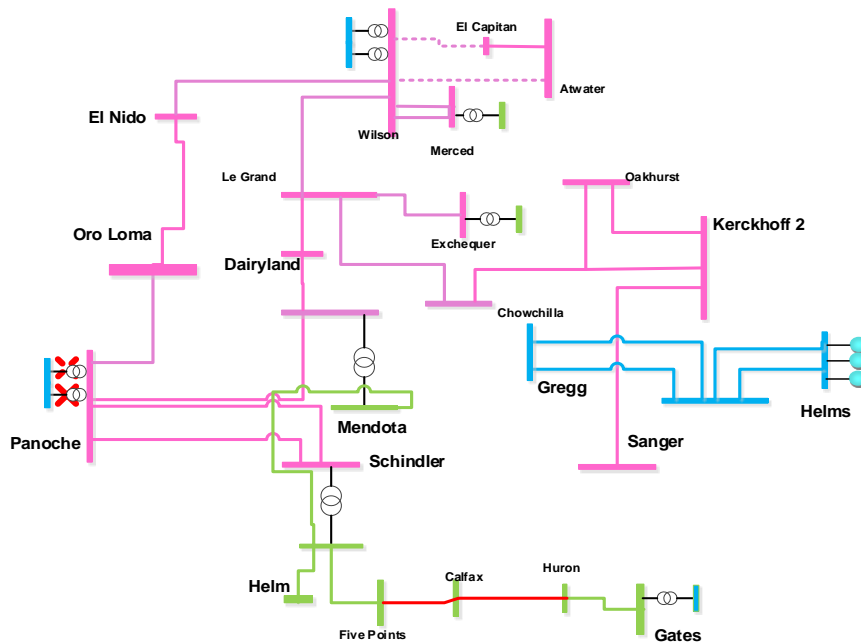

3.2.6.6.2 Panoche LCR Sub-area Load and Resources

Table 3.2-46 provides the forecast load and resources in Panoche LCR sub-area in 2025. The list of generators within the LCR sub-area are provided in Attachment A.

Table 3.2-46 Panoche LCR Sub-area 2025 Forecast Load and Resources

Load (MW)		Generation (MW)	Aug NQC	At Peak
Gross Load	427	Market, Net Seller	282	282
AAEE	-4	MUNI	100	100
Behind the meter DG	-1	QF	3	3
Net Load	422	Solar	89	40
Transmission Losses	8	Existing 20-minute Demand Response	0	0

Pumps	0	Mothballed	0	0
Load + Losses + Pumps	430	Total	474	425

3.2.6.6.3 Panoche LCR Sub-area Hourly Profiles

Figure 3.2-52 illustrates the forecast 2025 profile for the peak day for the Panoche LCR sub-area with the Category P6 normal and emergency load serving capabilities without local gas resources. The chart also includes an estimated amount of energy storage that can be added to this local area from charging restriction perspective. The energy storage amount is incremental to the existing system and doesn't include approved energy storage. Figure 3.2-53 illustrates the forecast 2025 hourly profile for Panoche LCR sub-area with the Category P6 emergency load serving capability without local gas resources.

Figure 3.2-52 Panoche LCR Sub-area 2025 Peak Day Forecast Profiles

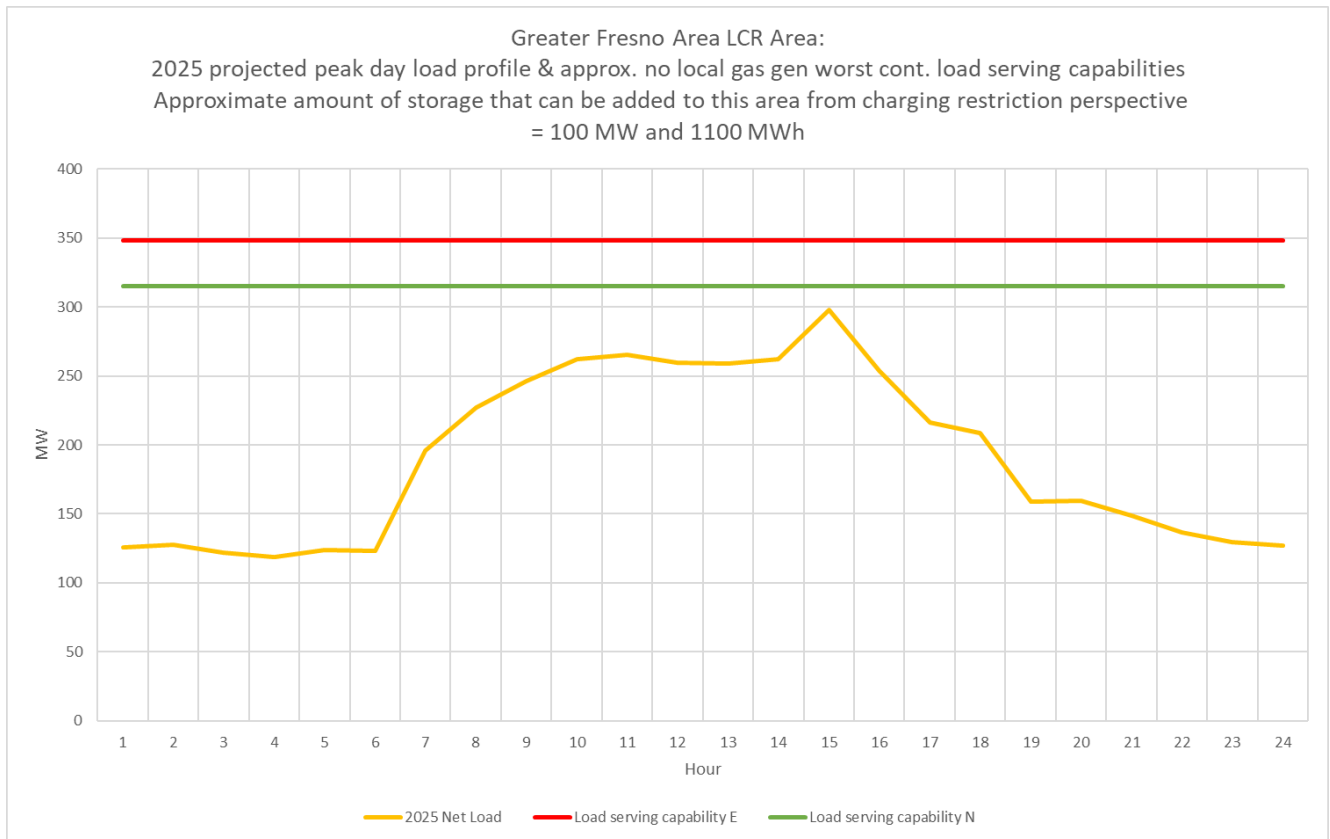
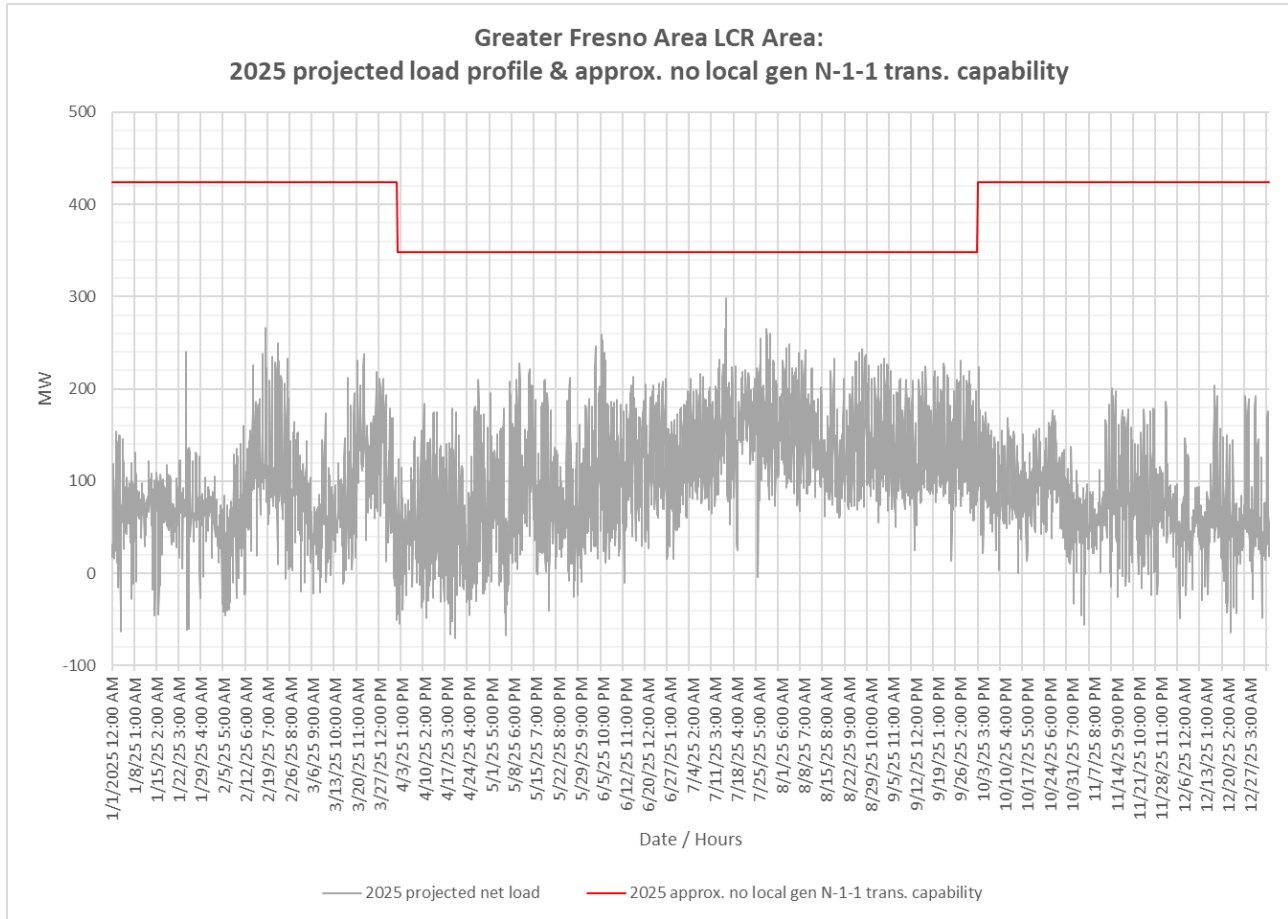

Figure 3.2-53 Panoche LCR Sub-area 2025 Forecast Hourly Profiles



3.2.6.6.4 Panoche LCR Sub-area Requirement

Table 3.2-47 identifies the sub-area LCR requirements. The LCR Requirement for a Category P6 contingency is 164 MW.

Table 3.2-47 Panoche LCR Sub-area Requirements

Year	Limit	Category	Limiting Facility	Contingency	LCR (MW) (Deficiency)
2025	First limit	P6	Five Points-Huron-Gates 70 kV line	Panoche 230/115 kV TB #2 and Panoche 230/115 kV TB #	164

3.2.6.6.5 Effectiveness factors:

Effective factors for generators in the Panoche LCR sub-area are in Attachment B table title [Panoche](#).

For other helpful procurement information please read procedure 2210Z Effectiveness Factors under 7430 (T-129) posted at: <http://www.caiso.com/Documents/2210Z.pdf>

3.2.6.7 Wilson 115 kV Sub-area

Wilson 115 kV sub-area will be eliminated due to the Wilson #3 230/115 kV transformer coming into service as part of the Wilson 115 kV area reinforcement transmission project.

3.2.6.8 Herndon Sub-area

Herndon is a Sub-area of the Fresno LCR Area.

3.2.6.8.1 Herndon LCR Sub-area Diagram

Figure 3.2-54 Herndon LCR Sub-area

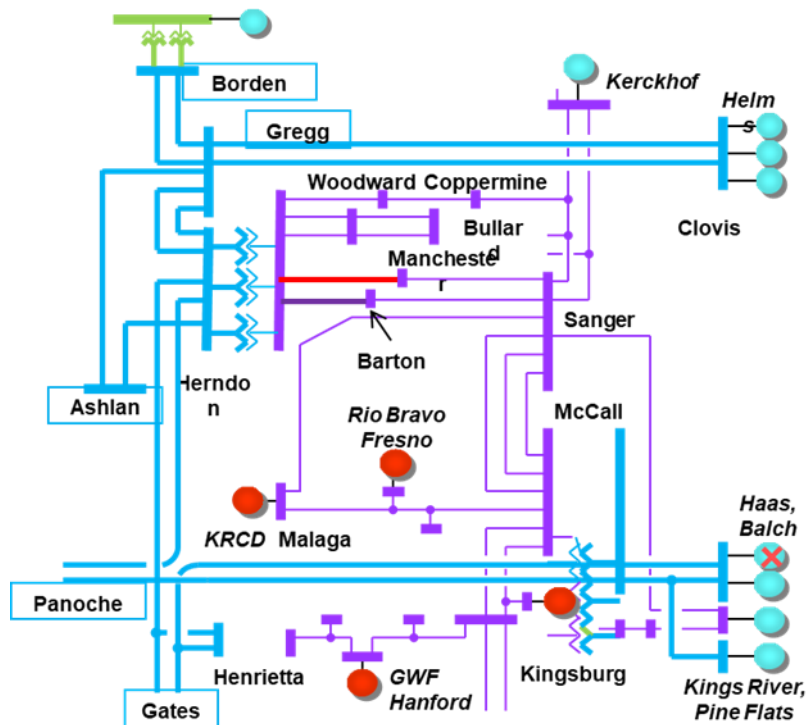

3.2.6.8.2 Herndon LCR Sub-area Load and Resources

Table 3.2-48 provides the forecast load and resources in Herndon LCR sub-area in 2024. The list of generators within the LCR sub-area are provided in Attachment A.

Table 3.2-48 Herndon LCR Sub-area 2025 Forecast Load and Resources

Load (MW)		Generation (MW)	Aug NQC	At Peak
Gross Load	1523	Market, Net Seller, Battery	997	997
AAEE	-13	MUNI	98	98

Behind the meter DG	-3	QF	1	1
Net Load	1507	Solar	63	28
Transmission Losses	25	Existing 20-minute Demand Response	0	0
Pumps	0	Mothballed	0	0
Load + Losses + Pumps	1532	Total	1159	1124

3.2.6.8.3 Herndon LCR Sub-area Hourly Profiles

Figure 3.2-55 illustrates the forecast 2025 profile for the peak day for the Herndon LCR sub-area with the Category P6 normal and emergency load serving capabilities without local gas resources. The chart also includes an estimated amount of energy storage that can be added to this local area from charging restriction perspective. The energy storage amount is incremental to the existing system and doesn't include approved energy storage. Figure 3.2-56 illustrates the forecast 2025 hourly profile for Herndon LCR sub-area with the Category P6 emergency load serving capability without local gas resources.

Figure 3.2-55 Herndon LCR Sub-area 2025 Peak Day Forecast Profiles

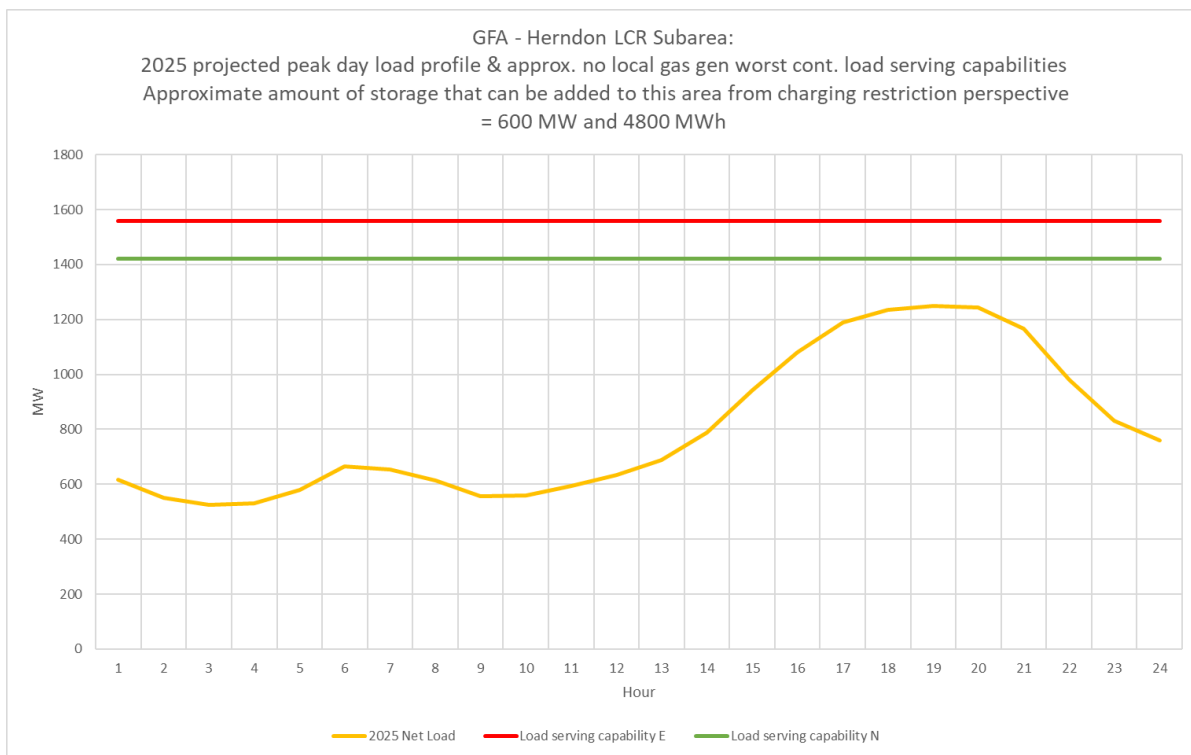
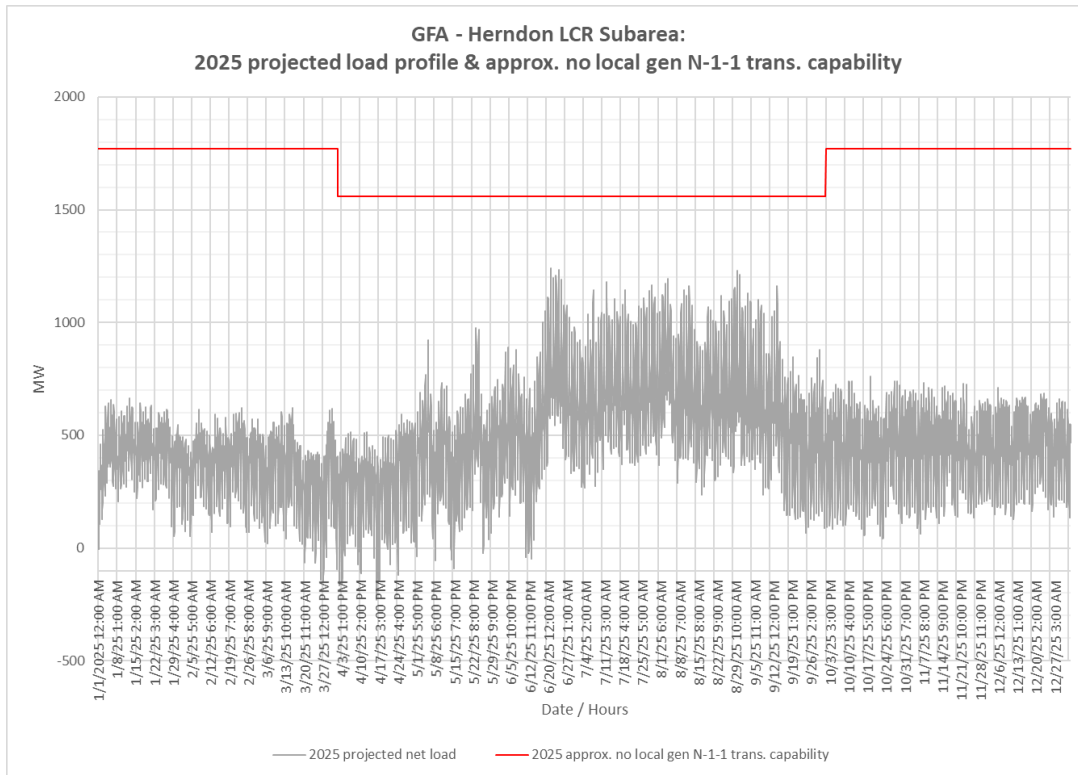

Figure 3.2-56 Herndon LCR Sub-area 2025 Forecast Hourly Profiles



3.2.6.8.4 Herndon LCR Sub-area Requirement

Table 3.2-49 identifies the sub-area LCR requirements. The LCR Requirement for a Category P6 contingency is 441 MW.

Table 3.2-49 Herndon LCR Sub-area Requirements

Year	Limit	Category	Limiting Facility	Contingency	LCR (MW) (Deficiency)
2025	First limit	P6	Herndon-Manchester 115 kV	Herndon-Woodward 115 kV line & Herndon-Barton 115 kV line	441

3.2.6.8.5 Effectiveness factors:

Effectiveness factors for generators in the Herndon LCR sub-area are in Attachment B table titled [Herndon](#).

For other helpful procurement information please read procedure 2210Z Effectiveness Factors under 7430 (T-129) posted at: <http://www.caiso.com/Documents/2210Z.pdf>

3.2.6.9 Fresno Overall area

3.2.6.9.1 Fresno LCR area Diagram

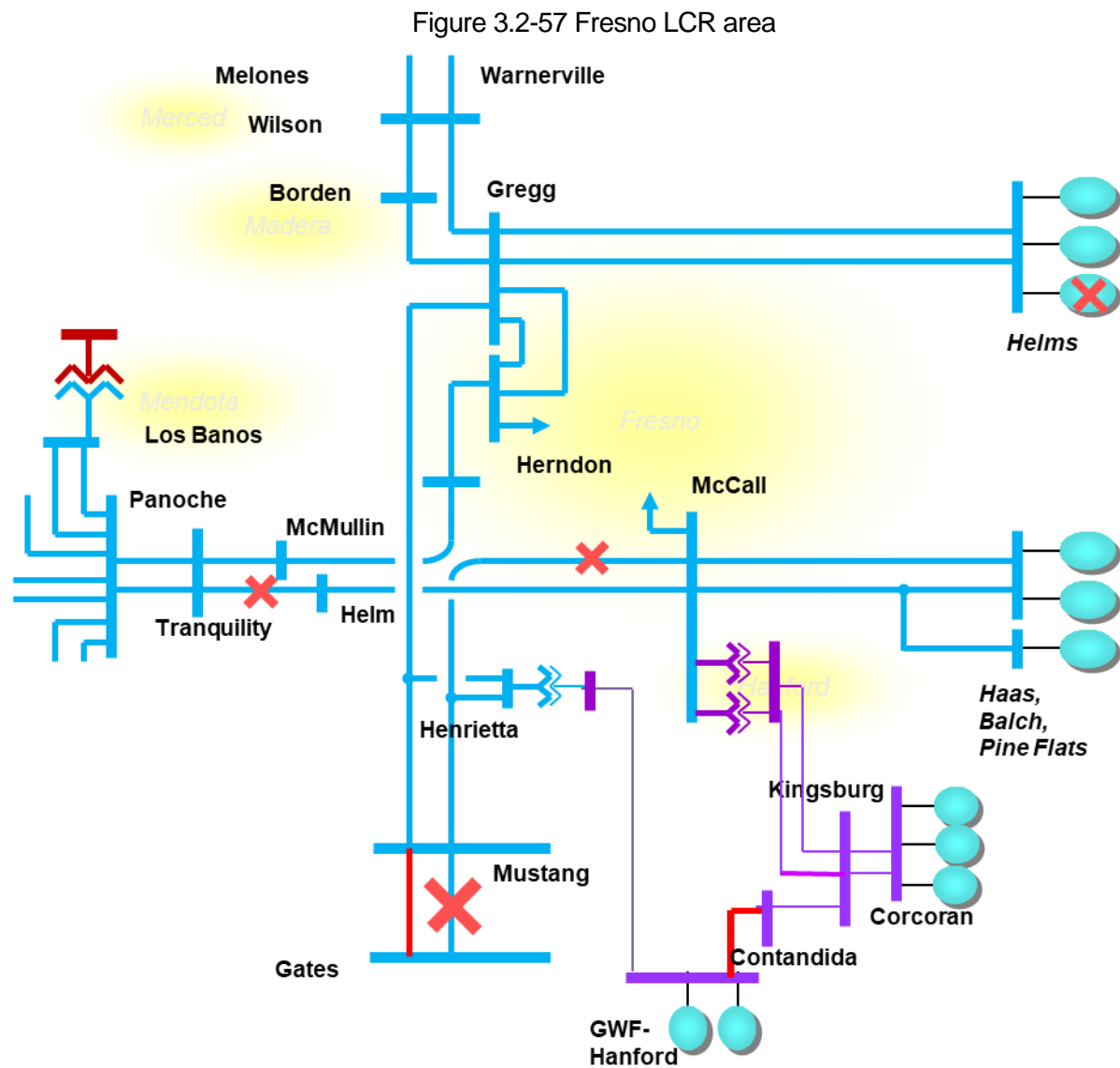

3.2.6.9.2 Fresno Overall LCR area Load and Resources

Table 3.2-37 provides the forecast load and resources in Fresno LCR area in 2025. The list of generators within the LCR area are provided in Attachment A.

3.2.6.9.3 Fresno Overall LCR area Hourly Profiles

Figure 3.2-58 illustrates the forecast 2025 profile for the peak day for the Overall LCR sub-area with the Category P6 normal and emergency load serving capabilities without local gas resources. The chart also includes an estimated amount of energy storage that can be added to this local area from charging restriction perspective. The energy storage amount is incremental to the existing system and doesn't include approved energy storage. Figure 3.2-59 illustrates the

forecast 2025 hourly profile for Overall LCR sub-area with the Category P6 emergency load serving capability without local gas resources.

Figure 3.2-58 Fresno LCR Area 2025 Peak Day Forecast Profiles

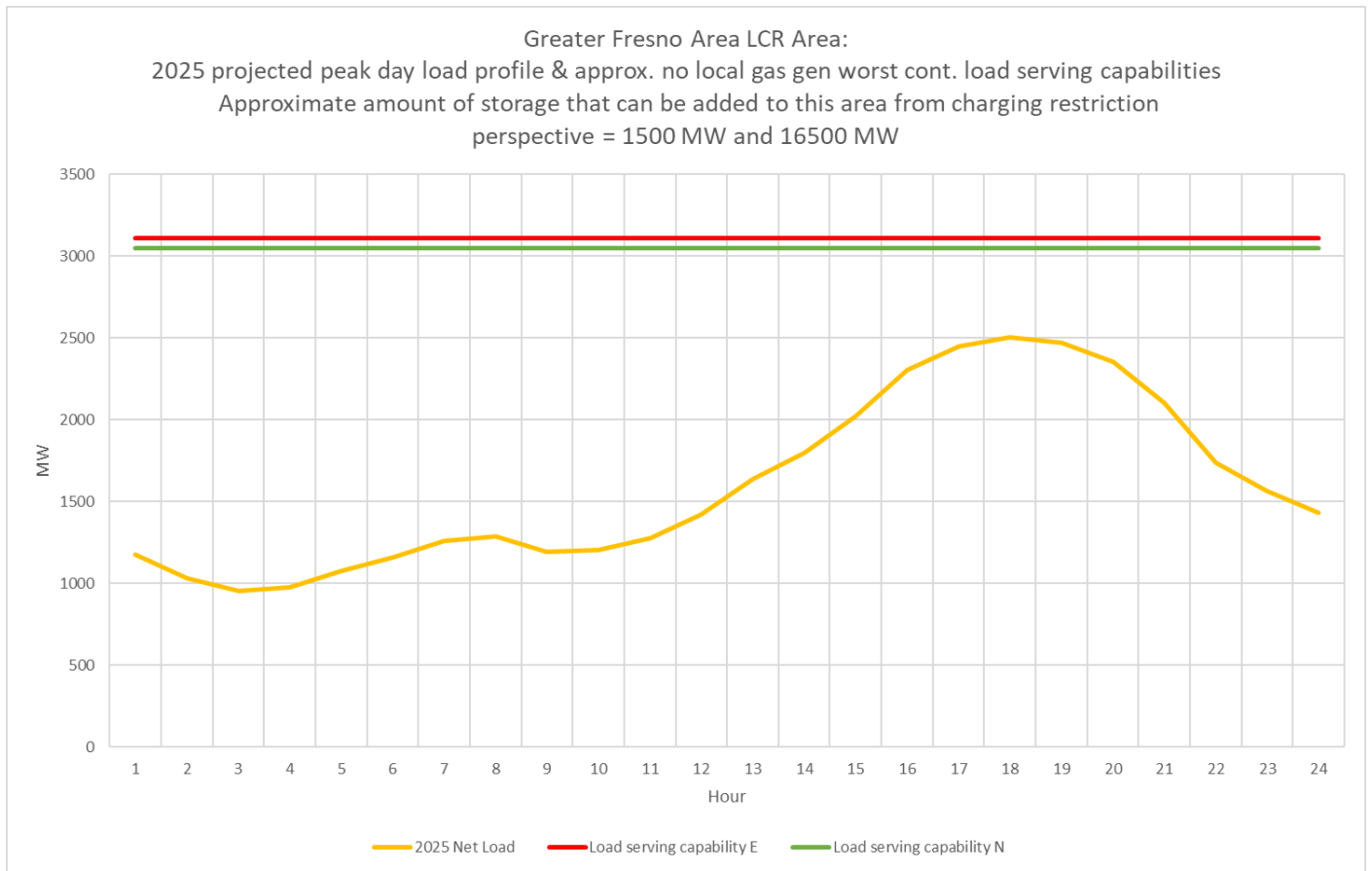
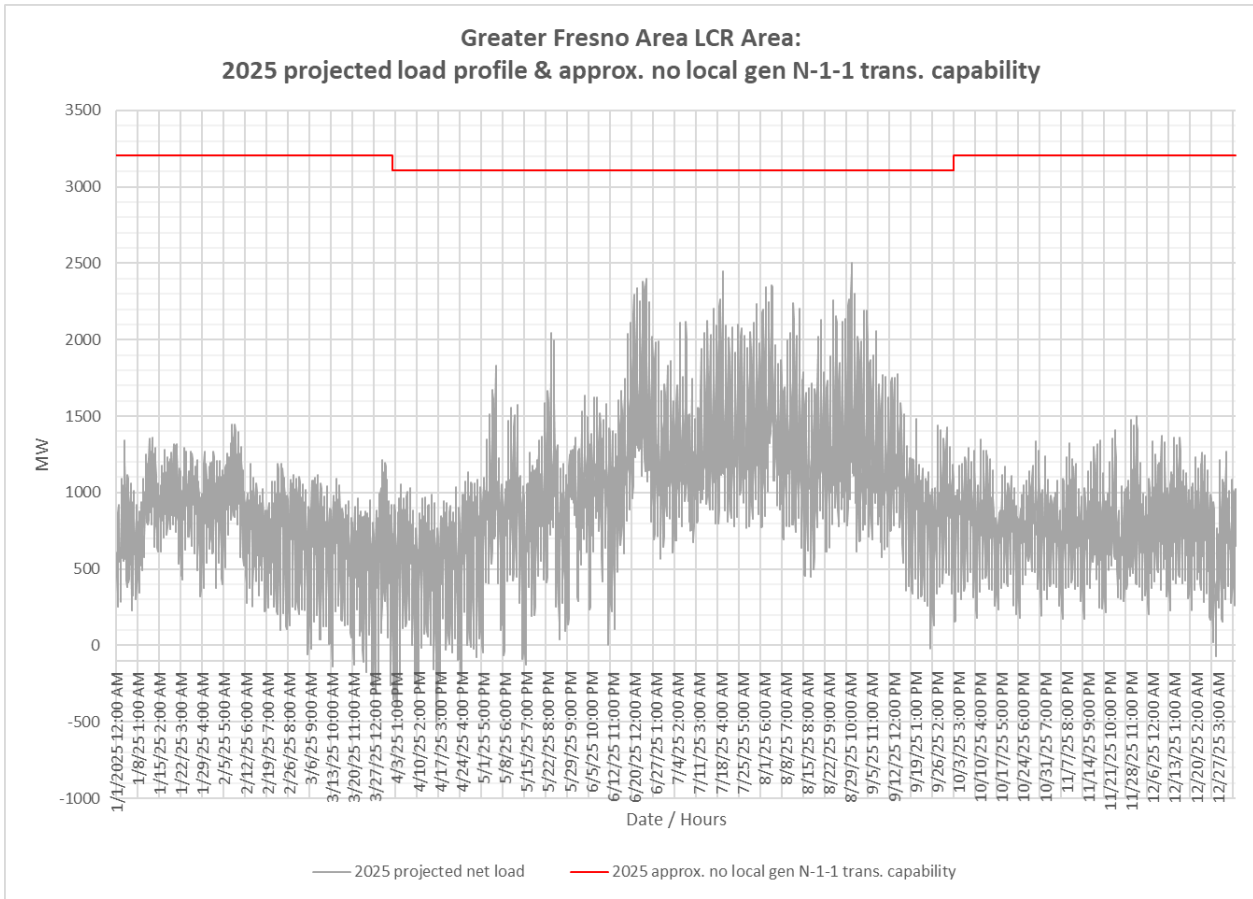

Figure 3.2-59 Fresno LCR Area 2025 Forecast Hourly Profiles



3.2.6.9.4 Fresno Overall LCR Area Requirement

Table 3.2-50 identifies the area LCR requirements. The LCR requirement Category P6 contingency is 1971 MW.

Table 3.2-50 Fresno Overall LCR Area Requirements

Year	Limit	Category	Limiting Facility	Contingency	LCR (MW) (Deficiency)
2025	First limit	P6	GWF-Contandida 115 kV Line	Panoche-Helm 230 kV Line and Gates-McCall 230 kV line	1971

3.2.6.9.5 Effectiveness factors:

For most helpful procurement information please read procedure 2210Z Effectiveness Factors under 7430 (T-129) posted at: <http://www.caiso.com/Documents/2210Z.pdf>

3.2.6.9.6 Changes compared to 2024 requirements

Compared with 2024 the load forecast decreased by 58 MW and the LCR has increased by 260 MW, due to newly identified contingency and limiting element.

3.2.7 Kern Area

3.2.7.1 Area Definition:

The transmission facilities coming into the Kern PP sub-area are:

- Midway-Kern PP #1 230 kV Line
- Midway-Kern PP #2 230 kV Line
- Midway-Kern PP #3 230 kV Line
- Midway-Kern PP #4 230 kV Line
- Midway-WheelerRidge 230 kV # 1
- Midway-WheelerRidge 230 kV # 2
- Famoso-Lerdo 115 kV Line (Normal Open)
- Wasco-Famoso 70 kV Line (Normal Open)
- Copus-Old River 70 kV Line (Normal Open)
- Copus-Old River 70 kV Line (Normal Open)

The substations that delineate the Kern-PP sub-area are:

- Midway 230 kV is out and Bakersfield 230 kV is in
- Midway 230 kV is out and Stockdale 230 kV is in
- Midway 230 kV is out Kern PP 230 kV is in
- Midway 230 kV is out and Buena Vista 230 kV is in
- Famoso 115 kV is out Cawelo 115 kV is in
- Wasco 70 kV is out Mc Farland 70 kV is in
- Copus 70 kV is out, South Kern Solar 70 kV is in
- Lakeview 70 kV is out, San Emidio Junction 70 kV is in

3.2.7.1.1 Kern LCR Area Diagram

Figure 3.2-60 Kern LCR Area

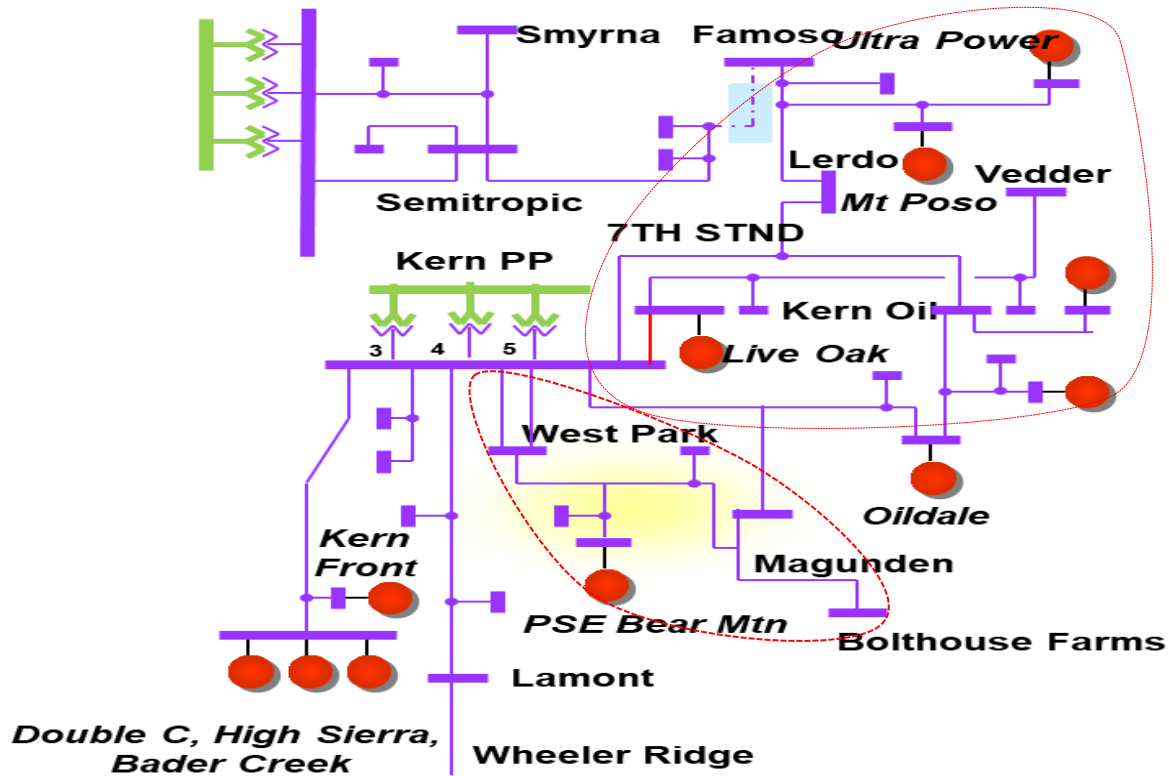

3.2.7.1.2 Kern LCR Area Load and Resources

Table 3.2-51 provides the forecast load and resources in Kern LCR area in 2025. The list of generators within the LCR area are provided in Attachment A.

In year 2025 the estimated time of local area peak is 19:20 PM.

At the local area peak time the estimated, ISO metered, solar output is 0.00%.

If required, all non-solar technology type resources are dispatched at NQC.

Table 3.2-51 Kern LCR Area 2025 Forecast Load and Resources

Load (MW)		Generation (MW)	Aug NQC	At Peak
Gross Load	1327 ⁶	Market, Net Seller	330	330
AAEE	-11	MUNI	0	0
Behind the meter DG	0	QF	5	5
Net Load	1316	Solar	78	0
Transmission Losses	15	Existing 20-minute Demand Response	0	0

⁶ Kern Area LCR definition has changed due to modeling of approved transmission upgrades

Pumps	320	Mothballed	0	0
Load + Losses + Pumps	1651	Total	413	335

3.2.7.1.3 Approved transmission projects modeled

- Kern PP 230 kV Area Reinforcement
- Bakersfield Nos. 1 and 2 230 kV Tap Lines Reconductoring
- Midway-Kern PP 230 kV #2 Line
- Midway-Kern PP 1, 3 & 4 230 kV Line Capacity Increase
- Kern PP 115 kV Area Reinforcement
- Wheeler Ridge Junction Station

3.2.7.2 Kern 70 kV Sub-area

Kern 70 kV is a sub-area of the Kern LCR Area.

3.2.7.2.1 Kern 70 kV LCR Sub-area Diagram

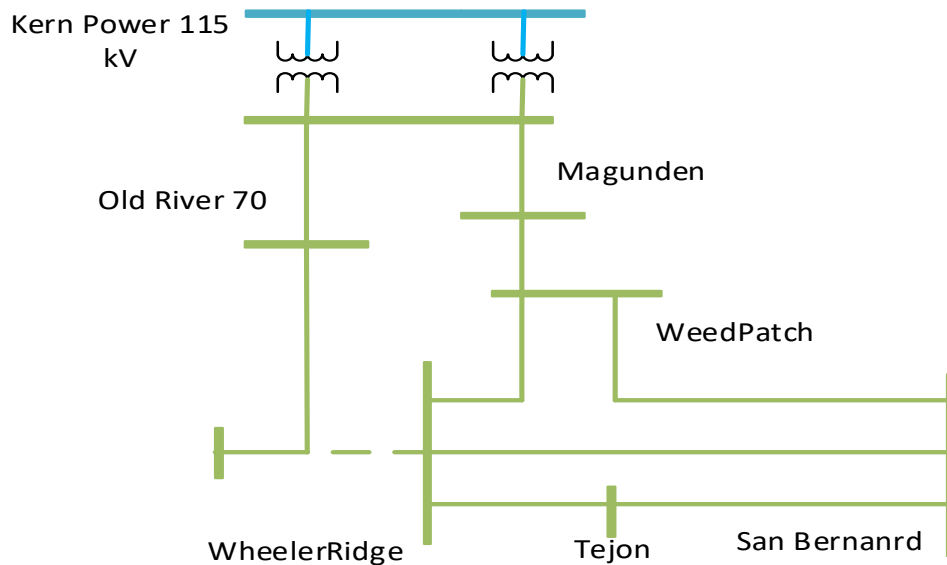

Figure 3.2-61 Kern 70 kV LCR Sub-area

3.2.7.2.2 Kern 70 kV LCR Sub-area Load and Resources

Table 3.2-52 provides the forecast load and resources in Kern 70 kV LCR sub-area in 2025. The list of generators within the LCR sub-area are provided in Attachment A.

Table 3.2-52 Kern 70 kV LCR Sub-area 2025 Forecast Load and Resources

Load (MW)	Generation (MW)	Aug NQC	At Peak
-----------	-----------------	---------	---------

Gross Load	242	Market, Net Seller	4	4
AAEE	-2	MUNI	0	0
Behind the meter DG	0	QF	0	0
Net Load	240	Solar	13	0
Transmission Losses	3	Existing 20-minute Demand Response	0	0
Pumps	0	Mothballed	0	0
Load + Losses + Pumps	243	Total	17	4

3.2.7.2.3 Kern 70 kV LCR Sub-area Hourly Profiles

Figure 3.2-62 illustrates the forecast 2025 profile for the summer peak, winter peak and spring off-peak days for the Kern 70 kV LCR sub-area with the Category P6 contingency transmission capability without resources. Figure 3.2-63 illustrates the forecast 2020 hourly profile for Kern 70 kV LCR sub-area with the Category P6 contingency transmission capability without resources.

Figure 3.2-62 Kern 70 kV LCR Sub-area 2025 Peak Day Forecast Profiles

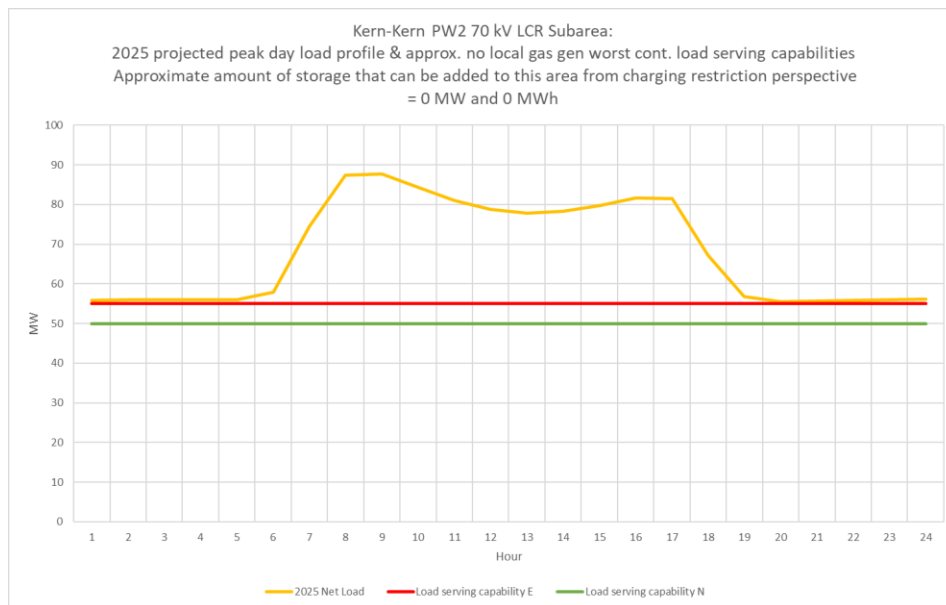
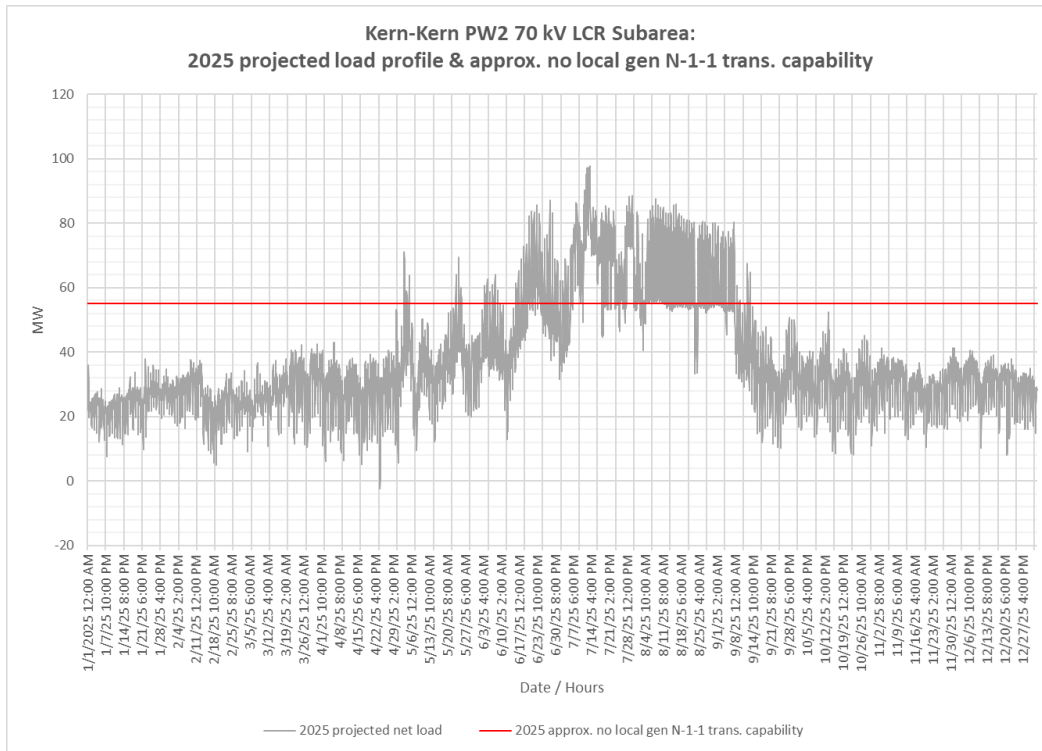

Figure 3.2-63 Kern 70 kV LCR Sub-area 2025 Forecast Hourly Profiles



3.2.7.2.4 Kern 70 kV LCR Sub-area Requirement

Table 3.2-53 identifies the sub-area LCR requirements. The LCR requirement for Category P6 contingency is 90 MW including a 73 MW NQC deficiency or 86 MW at peak deficiency.

Table 3.2-53 Kern 70 kV LCR Sub-area Requirements

Year	Limit	Category	Limiting Facility	Contingency	LCR (MW) (Deficiency)
2025	First Limit	P6	Weedpatch to Weedpatch SF 70 kV	Kern PW1 115/70 T/F & Kern PW2 115/70 T/F	90 (73 NQC/86 Peak)

3.2.7.2.5 Effectiveness factors:

All units within the Kern 70 kV sub-area have the same effectiveness factor.

For most helpful procurement information please read procedure 2210Z Effectiveness Factors under 7110 (T-138Z) posted at: <http://www.caiso.com/Documents/2210Z.pdf>

3.2.7.3 Westpark Sub-area

Westpark is a Sub-area of the Kern LCR Area.

3.2.7.3.1 Westpark LCR Sub-area Diagram

Please see Figure 3.2-60 for Westpark Sub-area diagram.

3.2.7.3.2 Westpark LCR Sub-area Load and Resources

Table 3.2-54 provides the forecast load and resources in Westpark LCR sub-area in 2025. The list of generators within the LCR sub-area are provided in Attachment A.

Table 3.2-54 Westpark LCR Sub-area 2025 Forecast Load and Resources

Load (MW)		Generation (MW)	Aug NQC	At Peak
Gross Load	165	Market, Net Seller	44	44
AAEE	-2	MUNI	0	0
Behind the meter DG	0	QF	0	0
Net Load	163	LTPP Preferred Resources	0	0
Transmission Losses	1	Existing 20-minute Demand Response	0	0
Pumps	0	Mothballed	0	0
Load + Losses + Pumps	164	Total	44	44

3.2.7.3.3 Westpark LCR Sub-area Hourly Profiles

Figure 3.2-64 illustrates the forecast 2025 profile for the summer peak, winter peak and spring off-peak days for the Westpark LCR sub-area with the Category P6 contingency transmission capability without resources. Figure 3.2-65 illustrates the forecast 2025 hourly profile for Westpark LCR sub-area with the Category P6 contingency transmission capability without resources.

Figure 3.2-64 Westpark LCR Sub-area 2025 Peak Day Forecast Profiles

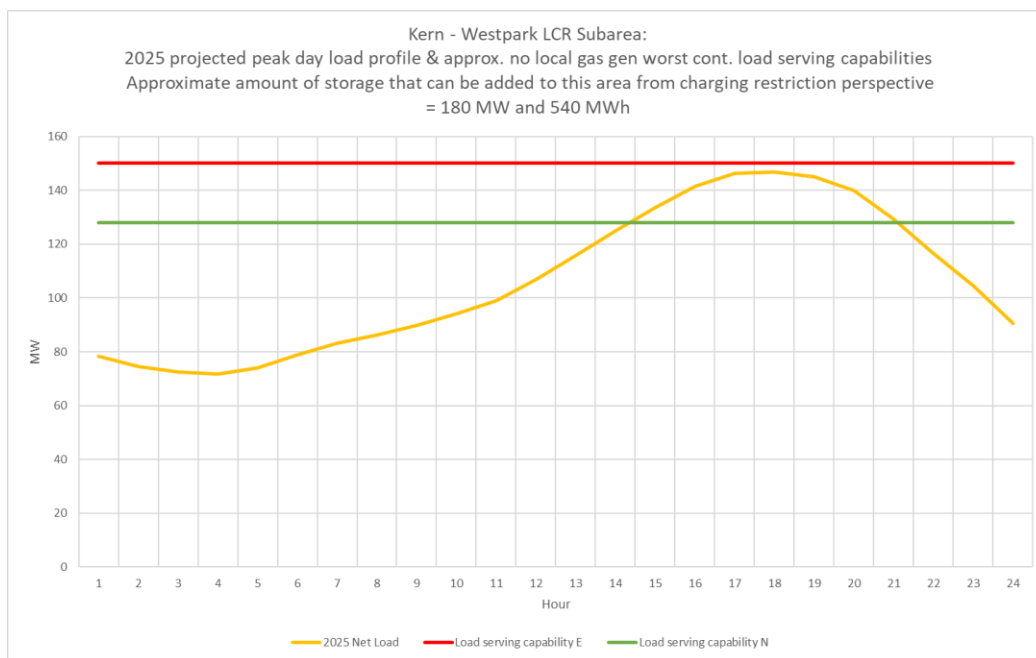
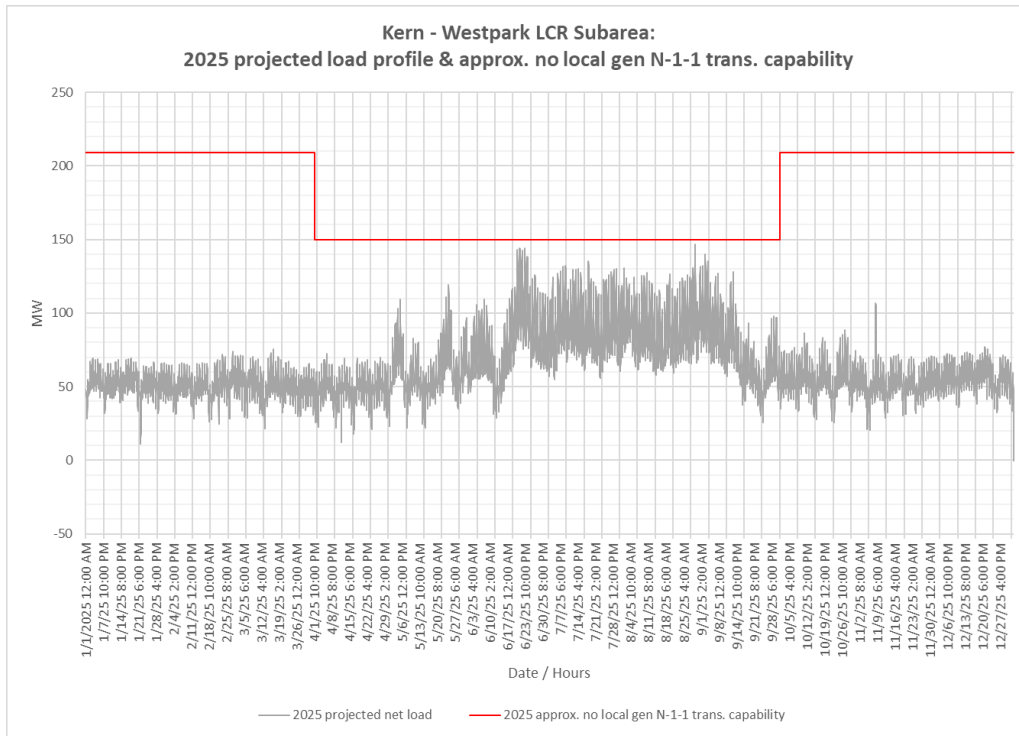

Figure 3.2-65 Westpark LCR Sub-area 2025 Forecast Hourly Profiles



3.2.7.3.4 Westpark LCR Sub-area Requirement

Table 3.2-55 identifies the sub-area LCR requirements. The LCR requirement for Category P6 contingency is 20 MW.

Table 3.2-55 Westpark LCR Sub-area Requirements

Year	Limit	Category	Limiting Facility	Contingency	LCR (MW) (Deficiency)
2025	First Limit	P6	Remaining Kern-West Park #1 or #2 115 kV	Kern-West Park #1 or # 2 115 kV & Magunden-Wheeler J # 115 kV	20

3.2.7.3.5 Effectiveness factors:

All units within the Westpark sub-area have the same effectiveness factor.

For most helpful procurement information please read procedure 2210Z Effectiveness Factors under 7110 (T-138Z) posted at: <http://www.aiso.com/Documents/2210Z.pdf>

3.2.7.4 Kern Oil Sub-area

Kern Oil is a Sub-area of the Kern LCR Area.

3.2.7.4.1 Kern Oil LCR Sub-area Diagram

Figure 3.2-66 Kern Oil LCR Sub-area

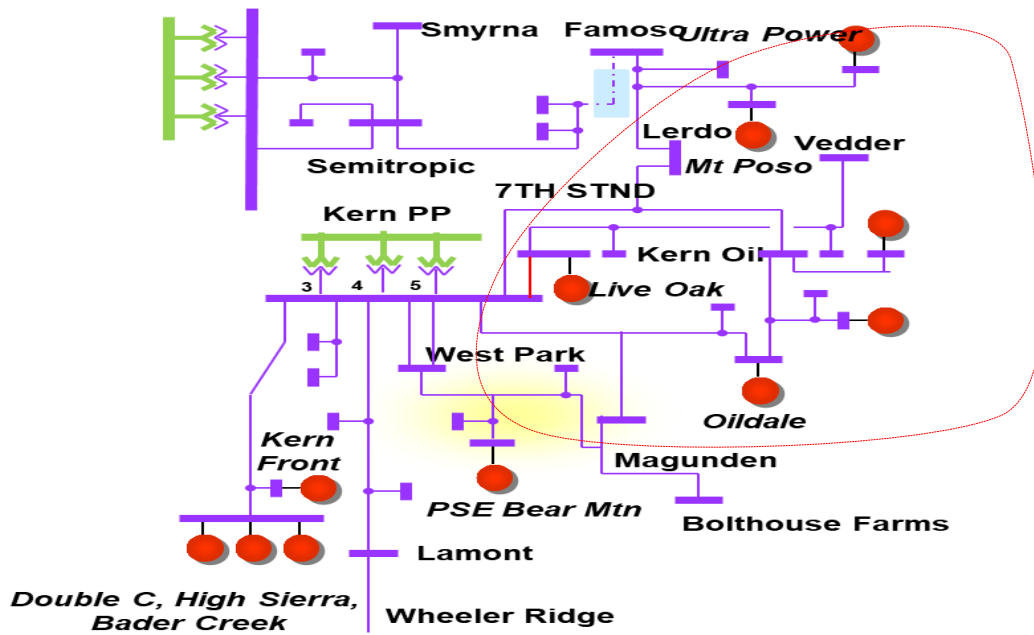

3.2.7.4.2 Kern Oil LCR Sub-area Load and Resources

Table 3.2-56 provides the forecast load and resources in Kern Oil LCR sub-area in 2025. The list of generators within the LCR sub-area are provided in Attachment A.

Table 3.2-56 Kern Oil LCR Sub-area 2025 Forecast Load and Resources

Load (MW)		Generation (MW)	Aug NQC	At Peak
Gross Load	300	Market	95	95
AAEE	-3	MUNI	0	0
Behind the meter DG	0	QF	5	5
Net Load	297	Solar	7	0
Transmission Losses	1	Existing 20-minute Demand Response	0	0
Pumps	0	Mothballed	0	0
Load + Losses + Pumps	298	Total	107	100

3.2.7.4.3 Kern Oil LCR Sub-area Hourly Profiles

Figure 3.2-67 illustrates the forecast 2025 profile for the summer peak, winter peak and spring off-peak days for the Kern Oil LCR sub-area with the Category P6 contingency transmission capability without resources. Figure 3.2-68 illustrates the forecast 2025 hourly profile for Kern Oil LCR sub-area with the Category P6 contingency transmission capability without resources.

Figure 3.2-67 Kern Oil LCR Sub-area 2025 Peak Day Forecast Profiles

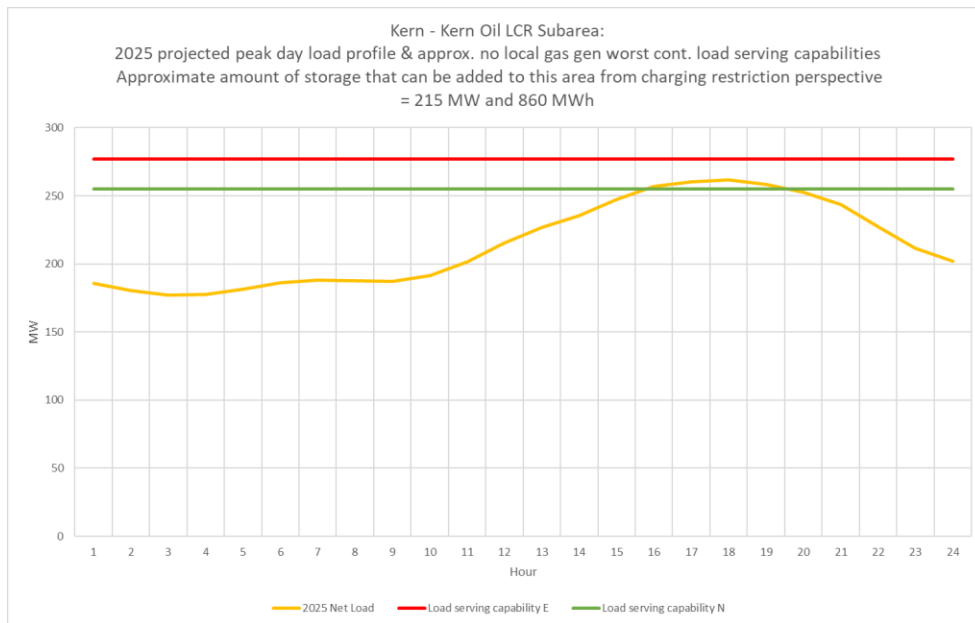
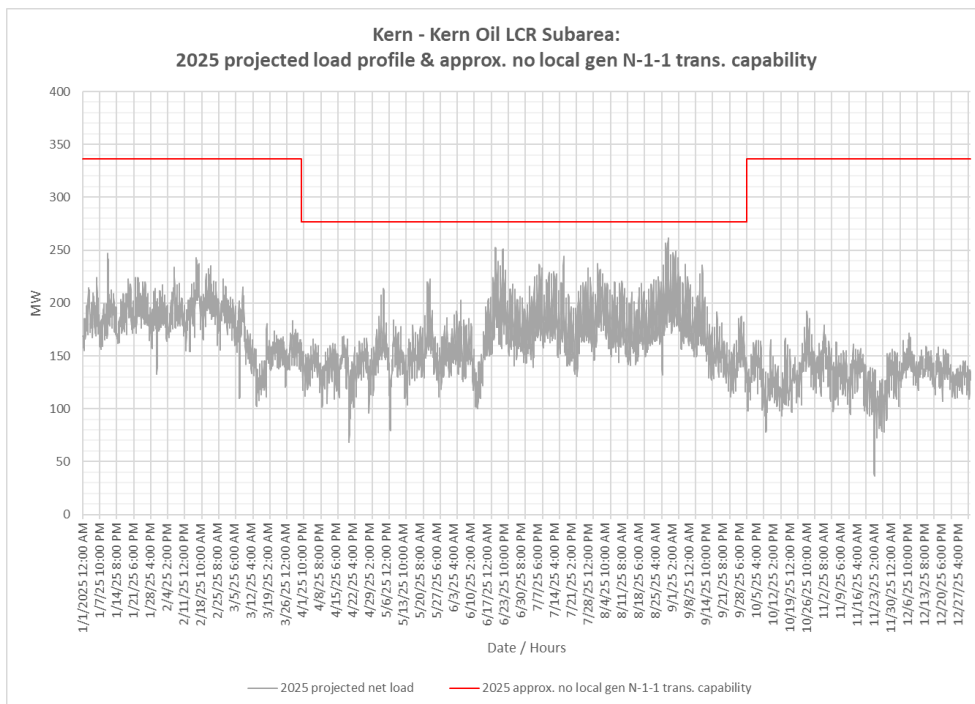

Figure 3.2-68 Kern Oil LCR Sub-area 2025 Forecast Hourly Profiles



3.2.7.4.4 Kern Oil LCR Sub-area Requirement

Table 3.2-57 identifies the sub-area LCR requirements. The LCR requirement for Category Category P6 contingency LCR requirement is 69 MW.

Table 3.2-57 Kern Oil LCR Sub-area Requirements

Year	Limit	Category	Limiting Facility	Contingency-	LCR (MW) (Deficiency)
2025	First Limit	P6	Kern Oil Jn to Golden Bear 115 kV line section	Kern PP-7th Standard 115 kV & Kern PP-Live Oak 115 kV	69

3.2.7.4.5 Effectiveness factors:

All units within the Kern Oil sub-area have the same effectiveness factor.

For most helpful procurement information please read procedure 2210Z Effectiveness Factors under 7110 (T-138Z) posted at: <http://www.caiso.com/Documents/2210Z.pdf>

3.2.7.5 South Kern PP Sub-area

South Kern PP is Sub-area of the Kern LCR Area.

3.2.7.5.1 South Kern PP LCR Sub-area Diagram

Figure 3.2-69 South Kern PP LCR Sub-area

3.2.7.5.2 South Kern PP LCR Sub-area Load and Resources

Refer to Table 3.2-51 Kern Area Load and Resources table.

3.2.7.5.3 South Kern PP LCR Sub-area Hourly Profiles

Figure 3.2-70 illustrates the forecast 2025 profile for the summer peak, winter peak and spring off-peak days for the South Kern PP LCR sub-area with the Category P6 contingency transmission capability without resources. Figure 3.2-71 illustrates the forecast 2025 hourly profile for South Kern PP LCR sub-area with the Category P6 contingency transmission capability without resources.

Figure 3.2-70 South Kern PP LCR Sub-area 2025 Peak Day Forecast Profiles

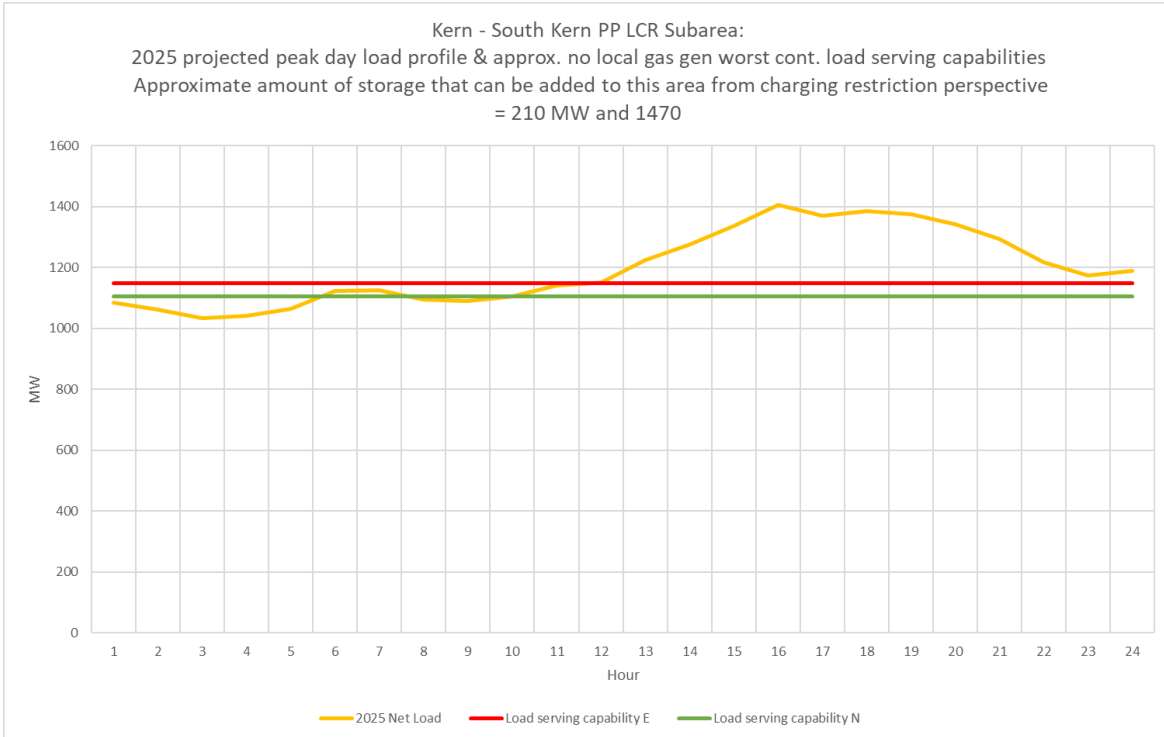
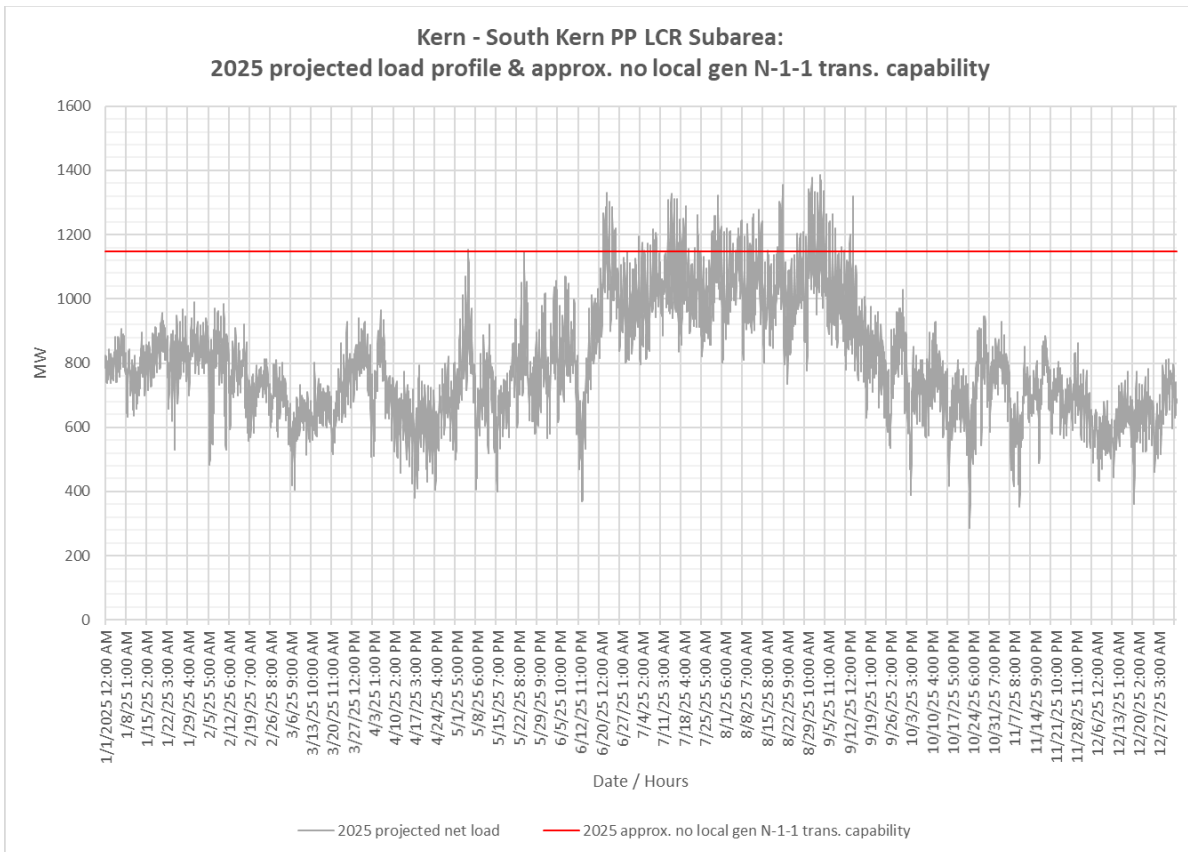

Figure 3.2-71 South Kern Overall LCR Area 2025 Forecast Hourly Profiles



3.2.7.5.4 South Kern PP LCR Sub-area Requirement

Table 3.2-58 identifies the sub-area LCR requirements. The LCR requirement for Category P6 contingency is 186 MW.

Table 3.2-58 South Kern PP LCR Sub-area Requirements

Year	Limit	Category	Limiting Facility	Contingency	LCR (MW) (Deficiency)
2025	First Limit	P6	Kern 230/115 kV T/F # 5	Kern 230/115 kV T/F # 3 & Kern 230/115 kV T/F # 4	186

3.2.7.5.5 Effectiveness factors:

For most helpful procurement information please read procedure 2210Z Effectiveness Factors under 7450 posted at: <http://www.aiso.com/Documents/2210Z.pdf>

3.2.7.6 Kern Area Overall Requirements

3.2.7.6.1 Kern LCR Area Overall Requirement

Table 3.2-59 identifies the limiting facility and contingency that establishes the Kern Area 2025 LCR requirements. The LCR requirement for Category P6 contingency the LCR requirement is 276 MW with a 73 MW NQC deficiency or 86 MW of at peak deficiency.

Table 3.2-59 Kern Overall LCR Sub-area Requirements

Year	Limit	Category	Limiting Facility	Contingency	LCR (MW) (Deficiency)
2025	N/A	P6	Aggregate of Sub-areas.		272 (73 NQC/ 86 Peak)

3.2.7.6.2 Kern Overall LCR Area Hourly Profile

Refer to South Kern PP LCR area profiles.

3.2.7.6.3 Changes compared to 2024 requirements

Compared with 2024, due to the definition change, the load has increased by 748 MW. The LCR requirement has increased by 120 MW mainly due to load forecast increase and change in LCR criteria.

3.2.8 Big Creek/Ventura Area

3.2.8.1 *Area Definition:*

The transmission tie lines into the Big Creek/Ventura Area are:

- Antelope #1 500/230 kV Transformer
- Antelope #2 500/230 kV Transformer
- Sylmar - Pardee 230 kV #1 and #2 Lines
- Vincent - Pardee 230 kV #2 Line
- Vincent - Santa Clara 230 kV Line

The substations that delineate the Big Creek/Ventura Area are:

- Antelope 500 kV is out Antelope 230 kV is in
- Antelope 500 kV is out Antelope 230 kV is in
- Sylmar is out Pardee is in
- Vincent is out Pardee is in
- Vincent is out Santa Clara is in

3.2.8.1.1 Big Creek/Ventura LCR Area Diagram

Figure 3.2-72 Big Creek/Ventura LCR Area

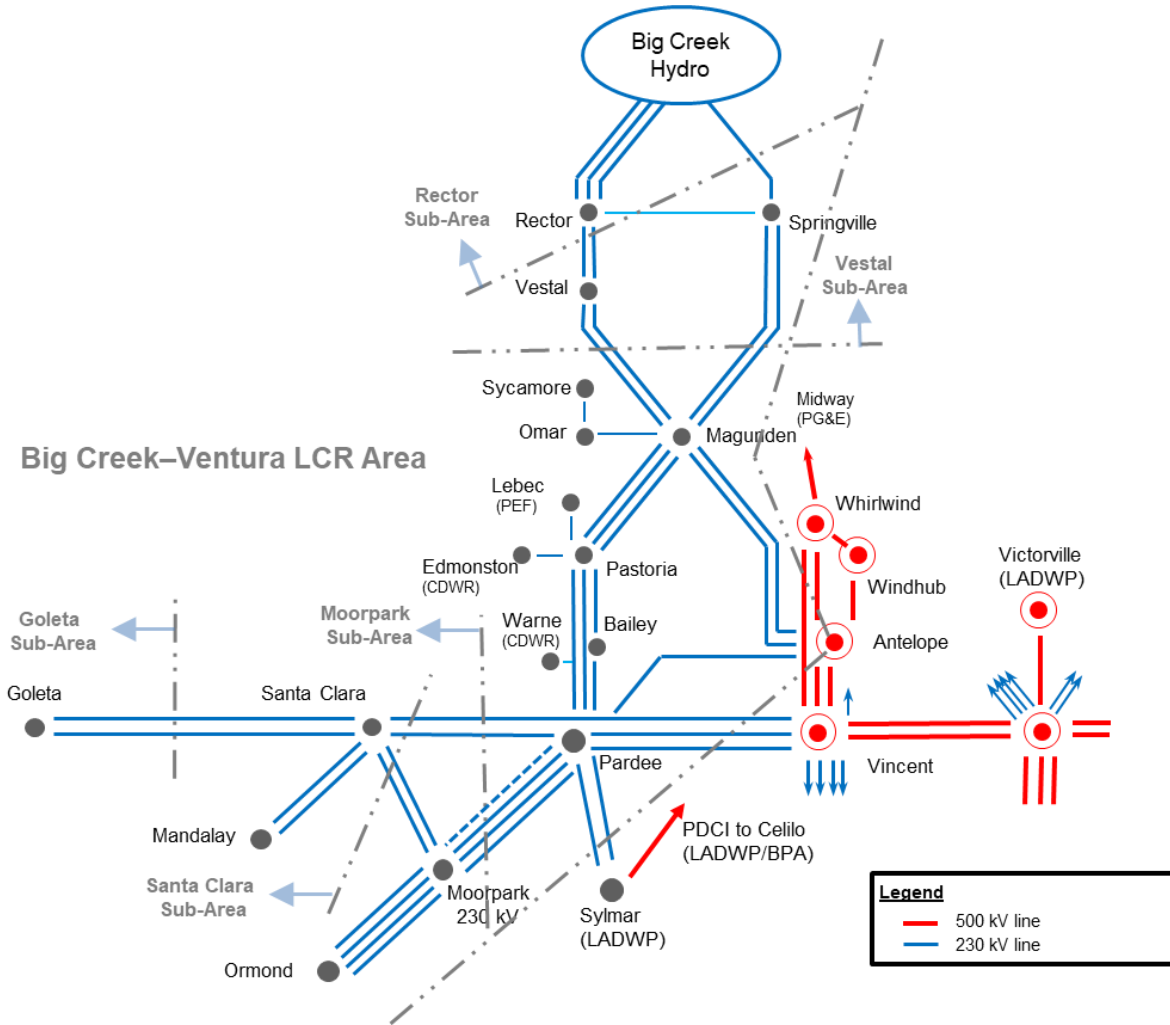

3.2.8.1.2 Big Creek/Ventura LCR Area Load and Resources

Table 3.2-60 provides the forecast load and resources in the Big Creek/Ventura LCR area in 2025. The list of generators within the LCR area are provided in Attachment A and does not include new LTPP Preferred resources or existing DR.

In year 2025 the estimated time of local area peak is 5:00 PM.

At the local area peak time the estimated, ISO-metered solar output is 21.9%.

If required, all non-solar technology type resources are dispatched at NQC.

Table 3.2-60 Big Creek/Ventura LCR Area 2025 Forecast Load and Resources

Load (MW)		Generation (MW)	Aug NQC	At Peak
Gross Load	4574	Market, Net Seller, Battery, Wind	2656	2656
AAEE	-76	MUNI	312	312
Behind the meter DG	-403	QF	112	112

Net Load	4095	Solar	250	250
Transmission Losses	59	LTPP Preferred Resources	207	207
Pumps	275	Existing 20-minute Demand Response	100	100
Load + Losses + Pumps	4429	Total	3637	3637

3.2.8.1.3 Approved transmission projects modeled:

Big Creek Corridor Rating Increase Project (completed).

Pardee-Moorpark No. 4 230 kV Transmission Circuit (ISD – 12/31/2020)

Sylmar–Pardee 230 kV Rating Increase Project (ISD – 05/2023)⁷

3.2.8.2 Rector Sub-area

LCR need is satisfied by the need in the larger Vestal sub-area.

3.2.8.3 Vestal Sub-area

Vestal is a Sub-area of the Big Creek/Ventura LCR Area.

3.2.8.3.1 Vestal LCR Sub-area Diagram

Figure 3.2-73 Vestal LCR Sub-area

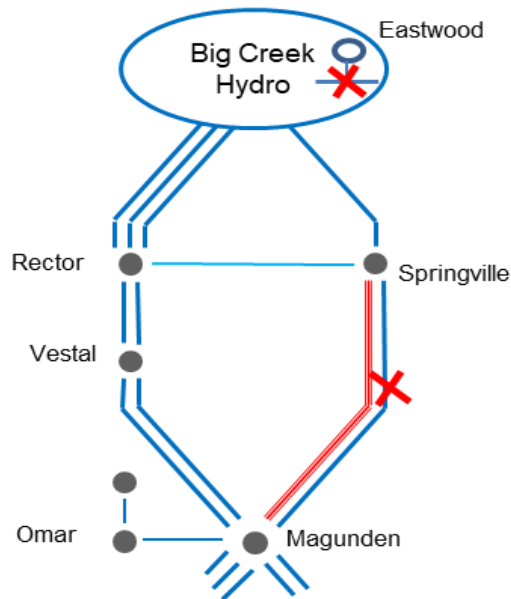

⁷ Most of the LCR study work was performed without the Sylmar–Pardee 230 kV Rating Increase Project as it was not approved by the CAISO Board yet. Subsequent to its approval, additional studies were performed for the Big Creek Ventura area to determine the LCR with the project included.

3.2.8.3.2 Vestal LCR Sub-area Load and Resources

Table 3.2-61 provides the forecast load and resources in Vestal LCR sub-area in 2025. The list of generators within the LCR sub-area are provided in Attachment A.

Table 3.2-61 Vestal LCR Sub-area 2025 Forecast Load and Resources

Load (MW)		Generation (MW)	Aug NQC	At Peak
Gross Load	N/A	Market, Net Seller, Battery, Wind	1055	1055
AAEE	N/A	MUNI	0	0
Behind the meter DG	N/A	QF	22	22
Net Load	1307	Solar	9	9
Transmission Losses	29	LTPP Preferred Resources	0	0
Pumps	0	Existing 20-minute Demand Response	41	41
Load + Losses + Pumps	1336	Total	1127	1127

3.2.8.3.3 Vestal LCR Sub-area Hourly Profiles

Figure 3.2-74 illustrates the forecast 2025 profile for the summer peak day in the Vestal LCR sub-area based on the CEC hourly forecast for the SCE area.

Figure 3.2-74 Vestal LCR Sub-area 2025 Peak Day Forecast Profiles

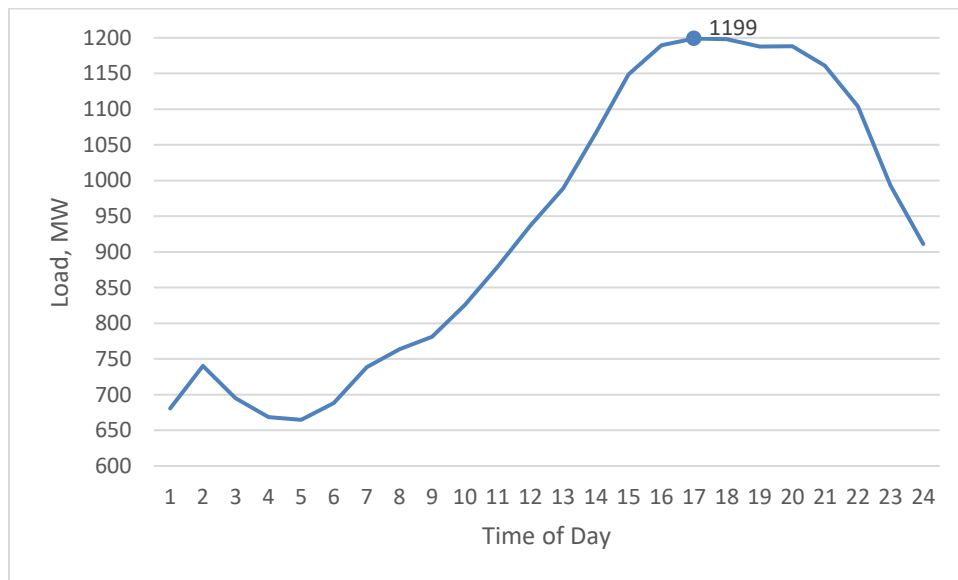

3.2.8.3.4 Vestal LCR Sub-area Requirement

Table 3.2-62 identifies the sub-area LCR requirements. The 2025 LCR requirement for Category P3 contingency are the same, is 310 MW.

Table 3.2-62 Vestal LCR Sub-area Requirements

Year	Limit	Category	Limiting Facility	Contingency	LCR (MW) (Deficiency)
2025	First Limit	P3	Magunden–Springville #2 230 kV line	Magunden–Springville #1 230 kV line with Eastwood out of service	310

3.2.8.3.5 Effectiveness factors:

For helpful procurement information please read procedure 2210Z Effectiveness Factors under 7500 posted at: <http://www.caiso.com/Documents/2210Z.pdf>

3.2.8.4 Goleta Sub-area

Goleta is a Sub-area of the Big Creek/Ventura LCR Area.

The LCR need is satisfied by the need in the larger Santa Clara sub-area.

3.2.8.5 Santa Clara Sub-area

Santa Clara is a Sub-area of the Big Creek/Ventura LCR Area.

3.2.8.5.1 Santa Clara LCR Sub-area Diagram

Figure 3.2-75 Santa Clara LCR Sub-area

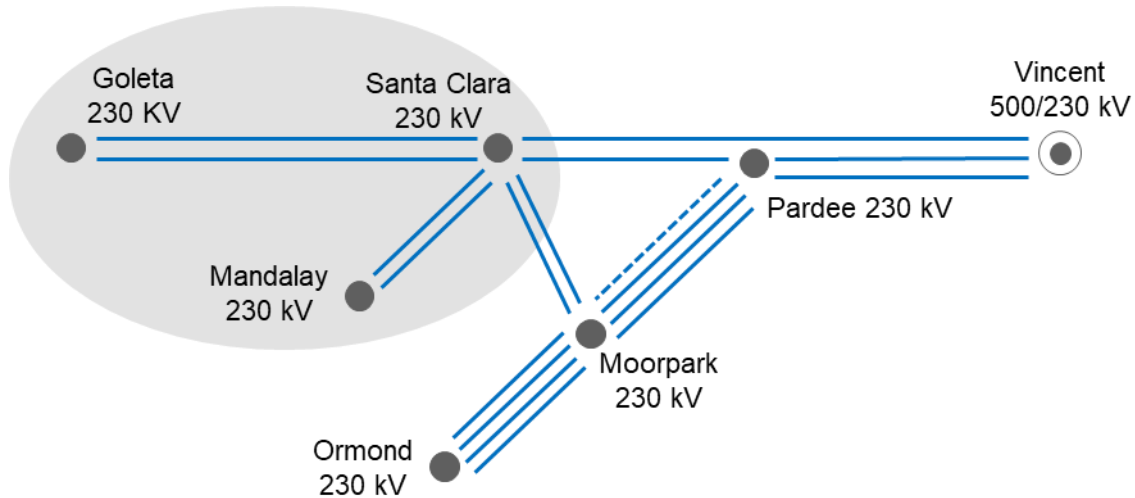

3.2.8.5.2 Santa Clara LCR Sub-area Load and Resources

Table 3.2-63 provides the forecast load and resources in Santa Clara LCR sub-area in 2025. The list of generators within the LCR sub-area are provided in Attachment A.

Table 3.2-63 Santa Clara LCR Sub-area 2025 Forecast Load and Resources

Load (MW)	Generation (MW)	Aug NQC	At Peak

Gross Load	N/A	Market	156	156
AAEE	N/A	MUNI	0	0
Behind the meter DG	N/A	QF	84	84
Net Load	793	LTPP Preferred Resources	195	195
Transmission Losses	2	Existing Demand Response	7	7
Pumps	0	Mothballed	0	0
Load + Losses + Pumps	795	Total	442	442

3.2.8.5.3 Santa Clara LCR Sub-area Hourly Profiles

Figure 3.2-76 illustrates the forecast 2025 profile for the summer peak day in the Santa Clara LCR sub-area based on the CEC forecast load shape for the SCE TAC area.

Figure 3.2-76 Santa Clara LCR Sub-area 2025 Peak Day Forecast Profiles

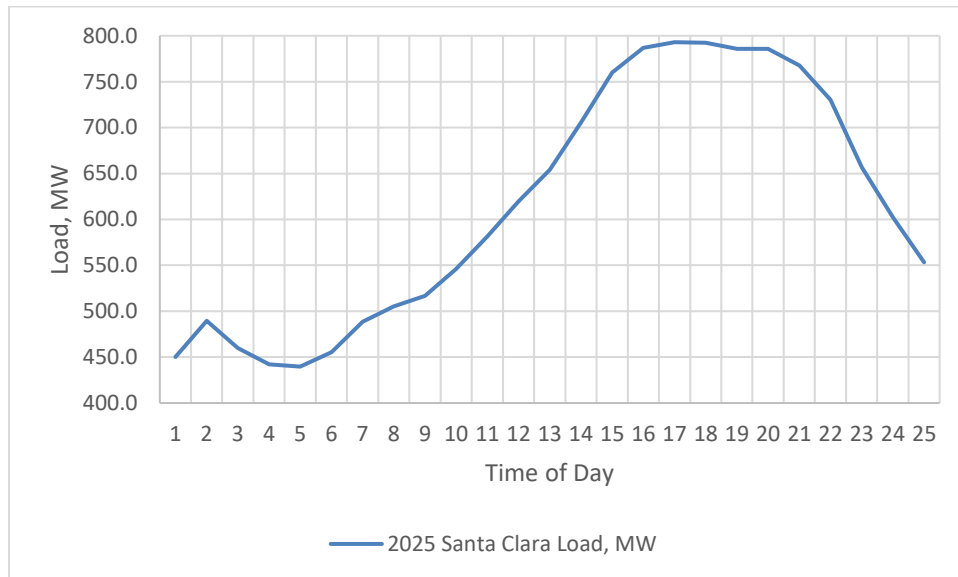

3.2.8.5.4 Santa Clara LCR Sub-area Requirement

Table 3.2-64 identifies the sub-area requirement. The LCR requirement for Category P1 + P7 contingency is 225 MW.

Table 3.2-64 Santa Clara LCR Sub-area Requirements

Year	Limit	Category	Limiting Facility	Contingency	LCR (MW) (Deficiency)

2025	First Limit	P1 + P7	Voltage collapse	Pardee - Santa Clara 230 kV followed by Moorpark - Santa Clara #1 & #2 230 kV	225
------	-------------	---------	------------------	---	-----

The Santa Clara sub-area could be energy deficient if the resources selected to meet the LCR do not include sufficient conventional generation. Figure 3.2-77 shows the scenario where the 229 MW LCR is to be filled with 195 MW of contracted storage, 7 MW of existing preferred resources and the remainder 23 MW with gas. In this scenario the the sub area will be energy deficient and will not have sufficient offpeak energy to charge additional batteries for next day use.

Figure 3.2-77 Santa Clara Sub-area Stoage Analysis

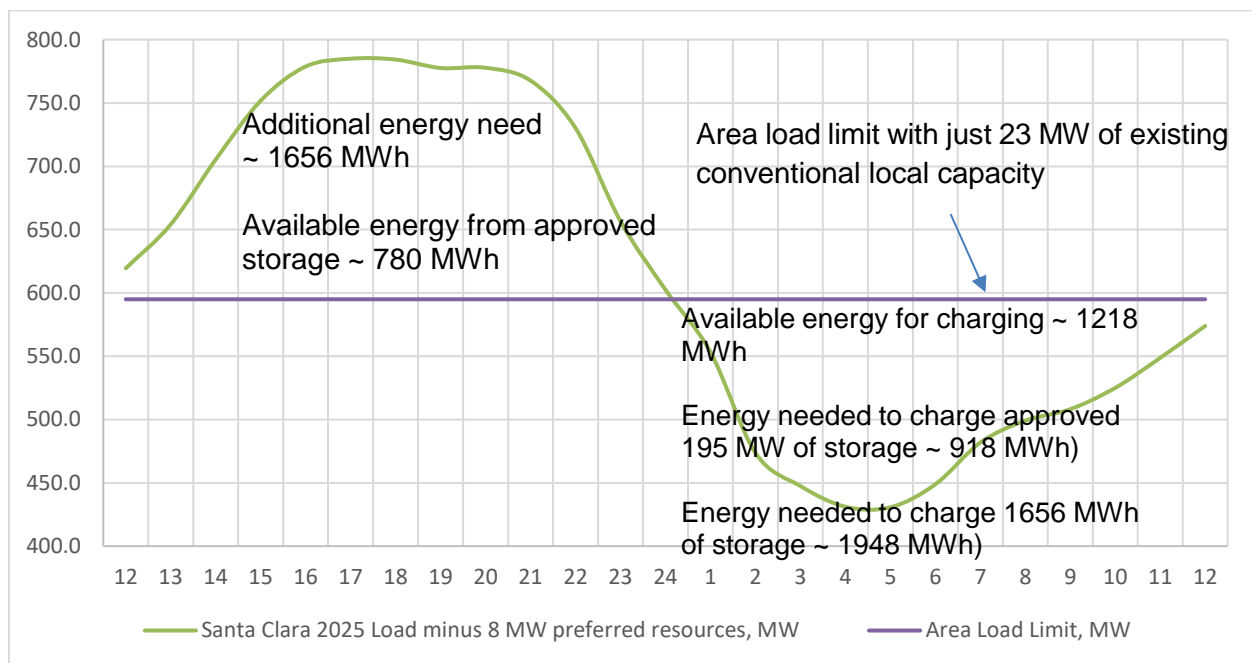

3.2.8.5.5 Effectiveness factors:

For helpful procurement information please read procedure 2210Z Effectiveness Factors under 7500 posted at: <http://www.caiso.com/Documents/2210Z.pdf>

3.2.8.6 Moorpark Sub-area

Moorpark is a Sub-area of the Big Creek/Ventura LCR Area.

No requirement is identified for the sub-area due Pardee-Moorpark No. 4 230 kV Transmission Project.

3.2.8.7 Big Creek/Ventura Overall

3.2.8.7.1 Big Creek/Ventura LCR Sub-area Hourly Profiles

Figure 3.2-78 illustrates the forecast 2025 profile for the summer peak day in the Big Creek/Ventura LCR area based on the CEC load shape for SCE TAC area.

Figure 3.2-78 Big Creek/Ventura LCR area 2025 Peak Day Forecast Profiles

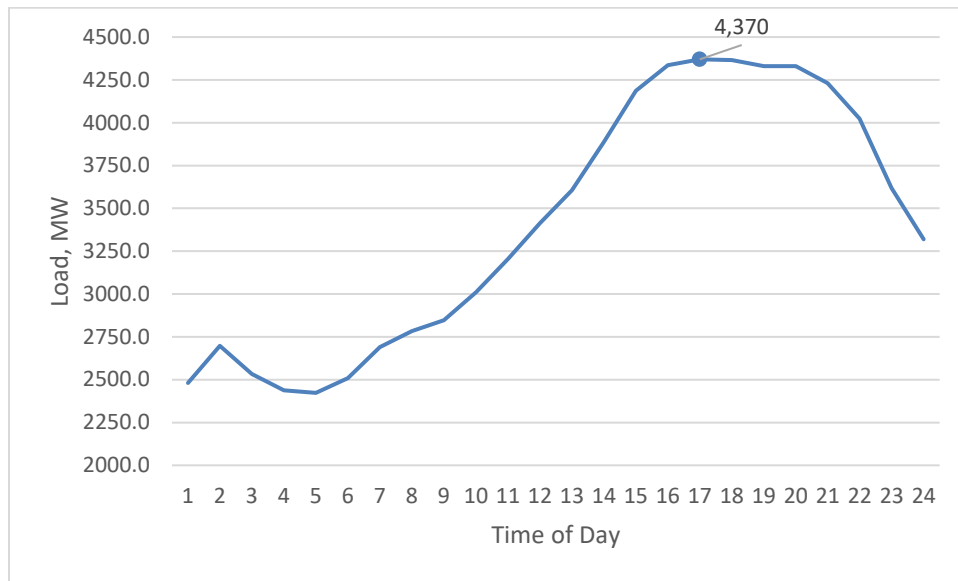

3.2.8.7.2 Big Creek/Ventura LCR area Requirement

Table 3.2-65 identifies the area LCR requirements. The LCR for the area was assessed with and without the Sylmar–Pardee 230 kV Rating Increase Project. The LCR requirement for Category P6 contingency is 1002 MW with the project and 2652 MW without the project.

Table 3.2-65 Big Creek/Ventura LCR area Requirements

Year	First Limit	Category	Limiting Facility	Contingency	LCR (MW) ⁸
2025	With Sylmar–Pardee Project	P6	Remaining Sylmar - Pardee 230 kV	Lugo - Victorville 500 kV line followed by one of the Sylmar - Pardee #1 or #2 230 kV lines	1002
2025	Without Sylmar–Pardee Project	P6	Remaining Sylmar - Pardee 230 kV	Lugo - Victorville 500 kV line followed by one of the Sylmar - Pardee #1 or #2 230 kV lines	2652

3.2.8.7.3 Effectiveness factors:

For helpful procurement information please read procedure 2210Z Effectiveness Factors under 7680 (T-130Z), 7510 (T-163Z), 7550 (T-159Z) and 8610 (T-131Z) posted at: <http://www.caiso.com/Documents/2210Z.pdf>

⁸The current assessment indicates a larger LCR reduction due to the Sylmar–Pardee project compared to the assessment that was performed for the project as part of the 2019-2020 TPP. The limiting contingency that established the LCR in the 2019-2020 TPP case was the P6 outage of one PDCI line and one Antelope 500/230 kV transformer which overloaded the remaining transformer. That contingency was not found to be binding in the current assessment likely due to the reduced output from renewables in the Antelope, Windhub and Whirlwind area that is modeled in the current base case because of the reduced NQC of wind and solar.

3.2.8.7.4 Changes compared to 2024 LCT study

Compared with the results for 2024 the load forecast is down by 529 MW and the LCR has increased by 75 MW despite the decrease in the load forecast. The LCR requirement went down by 1575 MW because of the Sylmar–Pardee 230 kV Rating Increase Project.

3.2.8.7.5 Energy Storage Analysis

The Big Creek-Ventura area and sub-areas were assessed to estimate the maximum amount of storage that can be added to displace local gas generation without exceeding the available off-peak charging capability in the area. The analysis is based on the following assumptions.

- Load shape is based on the CEC hourly forecast for SCE TAC area
- Energy storage is assumed to be added at the same location and amount as the displaced gas generation
- A round-trip efficiency of 85% is assumed for energy storage
- The assessment was initially performed without modeling the Sylmar–Pardee 230 kV upgrade project as its approval by the ISO Board was pending. Given its recent approval an assessment was performed with the project modeled.

Table 3.2-65 provides the results of the assessment. As shown in the table, adding storage for Rector, Vestal, Goleta, Santa Clara or Moorpark sub-areas will not enable displacing gas-fired generation because the subarea does not either have a local capacity requirement, the local capacity requirement is largely met by hydro resources or the area is already saturated with storage local capacity resources.

The assessment performed for the greater Big Creek-Ventura area without the Sylmar–Pardee Project shown in Figure 3.2-79 indicates roughly up to 882 MW/6667 MWh of new energy storage can be added to replace gas-fired local capacity without experiencing charging limitations. However, as can be seen in Figure 3.2-80 the approved Sylmar–Pardee project will eliminate the need for gas-fired local capacity in the area (with the exception of the Santa Clara sub-area) and as a result the addition of new storage will not result in the displacement of gas-fired local capacity.

Figure 3.2-79 Big Creek/Ventura Local Capacity Energy Storage Analysis without Sylmar–Pardee Project

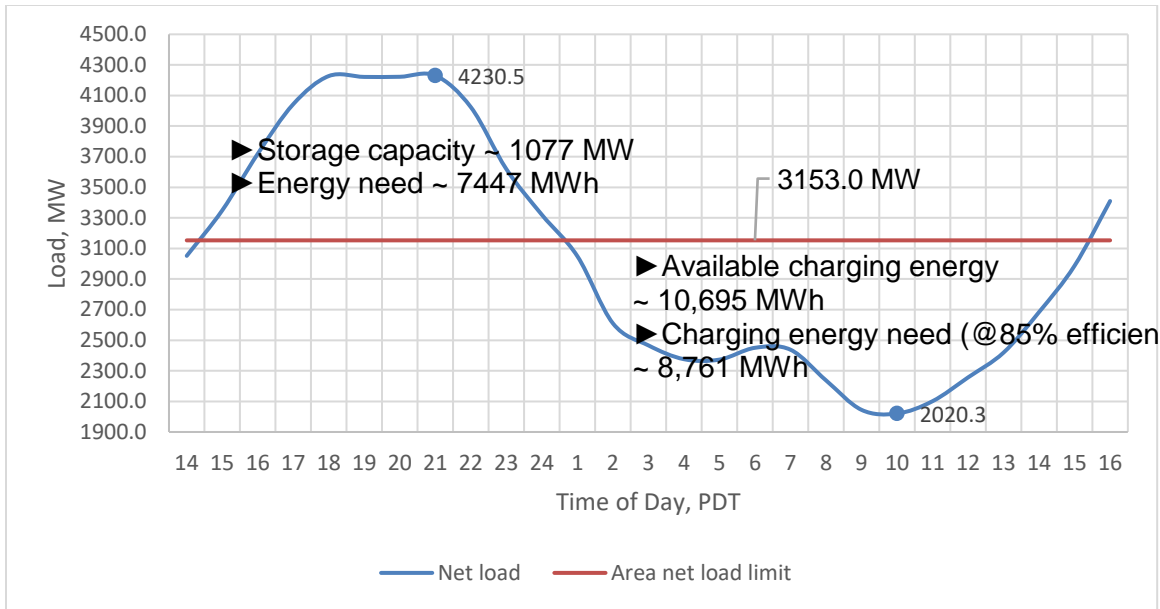

Figure 3.2-80 Big Creek/Ventura Local Capacity Energy Storage Analysis with Sylmar–Pardee Project

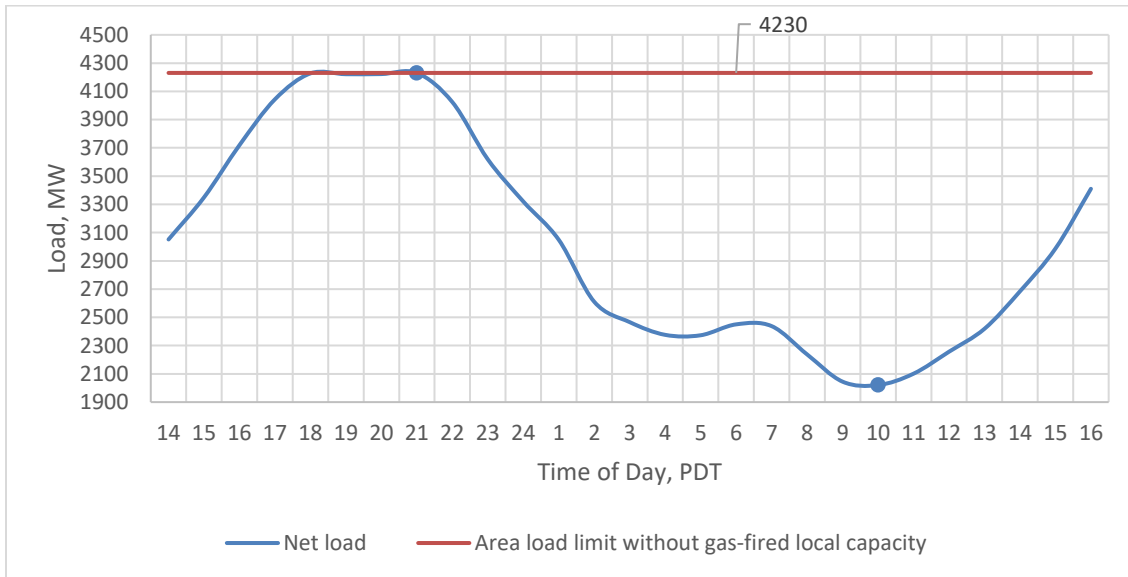

Table 3.2-66 Summary of Big Creek/Ventura Energy Storage Local Capacity Analysis Results

Area	LCR (2025), MW	Maximum energy storage that can be added to replace gas-fired local capacity		Remark
		Capacity (MW)	Energy (MWh)	
Rector	0	0	0	No LCR requirement
Vestal	310	0	0	No gas-fired local capacity
Goleta	0	0	0	No LCR requirement

Santa Clara	225	0	0	Area is saturated with approved energy storage
Moorpark	0	0	0	No LCR requirement
Overall Big Creek–Ventura Total	2,652	1,077	7447	Pre Sylmar–Pardee Project
Overall Big Creek–Ventura Incremental to approved ES		882	6667	
Overall Big Creek–Ventura Post Sylmar Pardee Project	1002	0	0	No gas-fired local capacity requirement post Sylmar–Pardee Project (other than in the Santa Clara sub-area)

3.2.9 LA Basin Area

3.2.9.1 Area Definition:

The transmission tie lines into the LA Basin Area are:

- San Onofre - San Luis Rey #1, #2, and #3 230 kV Lines
- San Onofre - Talega #1 230 kV Lines
- San Onofre - Capistrano #1 230 kV Lines
- Lugo - Mira Loma #2 & #3 500 kV Lines
- Lugo - Rancho Vista #1 500 kV Line
- Vincent – Mesa 500 kV Line
- Sylmar - Eagle Rock 230 kV Line
- Sylmar - Gould 230 kV Line
- Vincent - Mesa #1 & #2 230 kV Lines
- Vincent - Rio Hondo #1 & #2 230 kV Lines
- Devers - Red Bluff 500 kV #1 and #2 Lines
- Mirage – Coachella Valley # 1 230 kV Line
- Mirage - Ramon # 1 230 kV Line
- Mirage - Julian Hinds 230 kV Line

The substations that delineate the LA Basin Area are:

- San Onofre is in San Luis Rey is out
- San Onofre is in Talega is out

- San Onofre is in Capistrano is out
- Mira Loma is in Lugo is out
- Rancho Vista is in Lugo is out
- Eagle Rock is in Sylmar is out
- Gould is in Sylmar is out
- Mira Loma is in Vincent is out
- Mesa is in Vincent is out
- Rio Hondo is in Vincent is out
- Devers is in Red Bluff is out
- Mirage is in Coachella Valley is out
- Mirage is in Ramon is out
- Mirage is in Julian Hinds is out

3.2.9.1.1 LA Basin LCR Area Diagram

Figure 3.2-81 LA Basin LCR Area

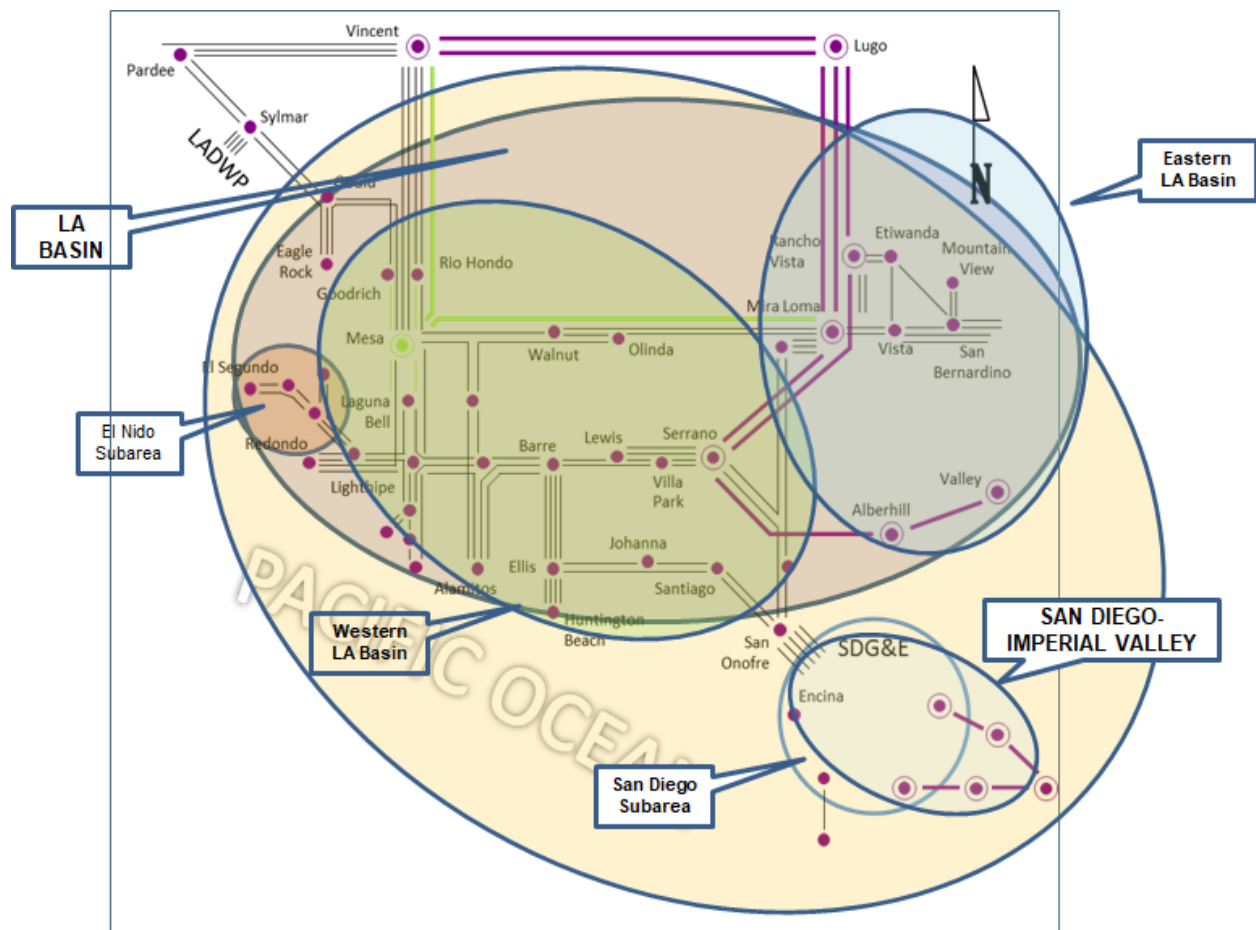

3.2.9.1.2 LA Basin LCR Area Load and Resources

Table 3.2-67 provides the forecast load and resources in the LA Basin LCR area in 2025. The list of generators within the LCR area are provided in Attachment A and does not include new LTPP Preferred resources or DR.

In year 2025 the estimated time of local area peak is 5:00 PM (PDT) on September 2, 2025.

At the local area peak time the estimated, ISO metered, solar output is 14%.

If required, all non-solar technology type resources are dispatched at NQC.

Table 3.2-67 LA Basin LCR Area 2025 Forecast Load and Resources

Load (MW)		Generation (MW)	Aug NQC	At Peak
Gross Load	21065	Market, Net Seller, Battery, Wind	5597	5597
AAEE	-382	MUNI	1056	1056
Behind the meter DG	-2,159	QF	141	141
Net Load	18524	LTPP Preferred Resources (BTM BESS, EE, DR, PV)	331	331
Transmission Losses	282	Existing Demand Response	287	287
Pumps	20	Solar	11	11
Load + Losses + Pumps	18826	Total	7423	7423

3.2.9.1.3 Approved transmission and resource projects modeled:

Mesa Loop-In Project and Laguna Bell Corridor 230 kV line upgrades

Delaney – Colorado River 500 kV Line

West of Devers 230 kV line upgrades

CPUC-approved long-term procurement plan for preferred resources in the western LA Basin sub-area

Retirement of Redondo Beach OTC generation (Units 5, 6 and 8)

Alamitos repowering

Alamitos battery energy storage system (100 MW / 400 MWh)

Retirement of Alamitos OTC generation (Units 3, 4, and 5)

Huntington Beach repowering

Retirement of Huntington Beach OTC generation

Stanton Energy Reliability Center (98 MW)

3.2.9.2 El Nido Sub-area

El Nido is Sub-area of the LA Basin LCR Area.

3.2.9.2.1 El Nido LCR Sub-area Diagram

Please refer to Figure 3.2-81 above.

3.2.9.2.2 El Nido LCR Sub-area Load and Resources

Table 3.2-68 provides the forecast load and resources in El Nido LCR sub-area in 2025. The list of generators within the LCR sub-area are provided in Attachment A.

Table 3.2-68 El Nido LCR Sub-area 2025 Forecast Load and Resources

Load (MW)		Generation (MW)	Aug NQC	At Peak
Gross Load	1086	Market, Net Seller, Battery, Wind, Solar	534	534
AAEE	-34	MUNI	3	3
Behind the meter DG	-47	QF	0	0
Net Load	1005	LTPP Preferred Resources	23	23
Transmission Losses	2	Existing Demand Response	9	9
Pumps	0	Mothballed	0	0
Load + Losses + Pumps	1007	Total	569	569

3.2.9.2.3 El Nido LCR Sub-area Hourly Profiles

Figure 3.2-82 illustrates the forecast 2025 profile for the summer peak day in the El Nido LCR sub-area.

Figure 3.2-82 El Nido LCR Sub-area 2025 Peak Day Forecast Profiles

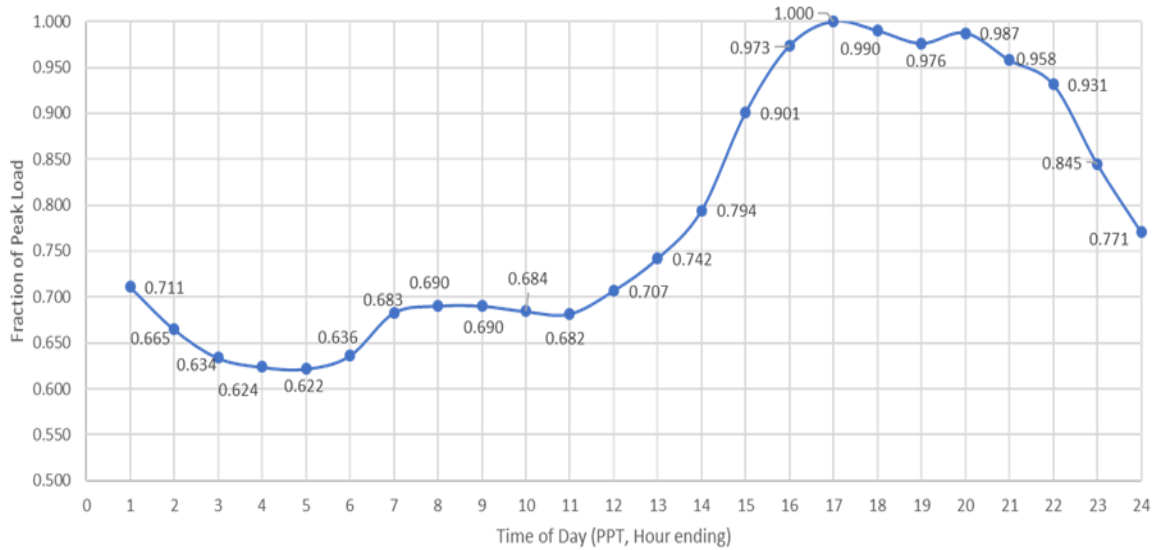

3.2.9.2.4 El Nido LCR Sub-area Requirement

Table 3.2-69 identifies the sub-area requirements. The LCR requirement for Category P7 contingency is 409 MW.

Table 3.2-69 El Nido LCR Sub-area Requirements

Year	Limit	Category	Limiting Facility	Contingency	LCR (MW) (Deficiency)
2025	First Limit	P7	La Fresa-La Cienega 230 kV	La Fresa – El Nido #3 & #4 230 kV	409

3.2.9.2.5 Effectiveness factors:

All units within the El Nido sub-area have the same effectiveness factor.

For most helpful procurement information please read procedure 2210Z Effectiveness Factors under 7630 (G-219Z) posted at: <http://www.caiso.com/Documents/2210Z.pdf>

3.2.9.3 Western LA Basin Sub-area

Western LA Basin is a Sub-area of the LA Basin LCR Area.

3.2.9.3.1 Western LA Basin LCR Sub-area Diagram

Please refer to Figure 3.2-81 above.

3.2.9.3.2 Western LA Basin LCR Sub-area Load and Resources

Table 3.2-70 provides the forecast load and resources in Western LA Basin LCR sub-area in 2025. The list of generators within the LCR sub-area are provided in Attachment A.

Table 3.2-70 Western LA Basin Sub-area 2025 Forecast Load and Resources

Load (MW)		Generation (MW)	Aug NQC	At Peak
Gross Load	12309	Market, Net Seller, Battery, Wind	3212	3212
AAEE	-466	MUNI	584	584
Behind the meter DG	-719	QF	58	58
Net Load	11124	LTPP Preferred Resources (BTM BESS, EE, DR, PV)	331	331
Transmission Losses	167	Existing Demand Response	161	161
Pumps	0	Solar	2	2
Load + Losses + Pumps	11291	Total	4348	4348

3.2.9.3.3 Western LA Basin LCR Sub-area Hourly Profiles

Figure 3.2-83 illustrates the forecast 2025 profile for the summer peak day in the Western LA Basin LCR sub-area.

Figure 3.2-83 Western LA Basin LCR Sub-area 2025 Peak Day Forecast Profiles

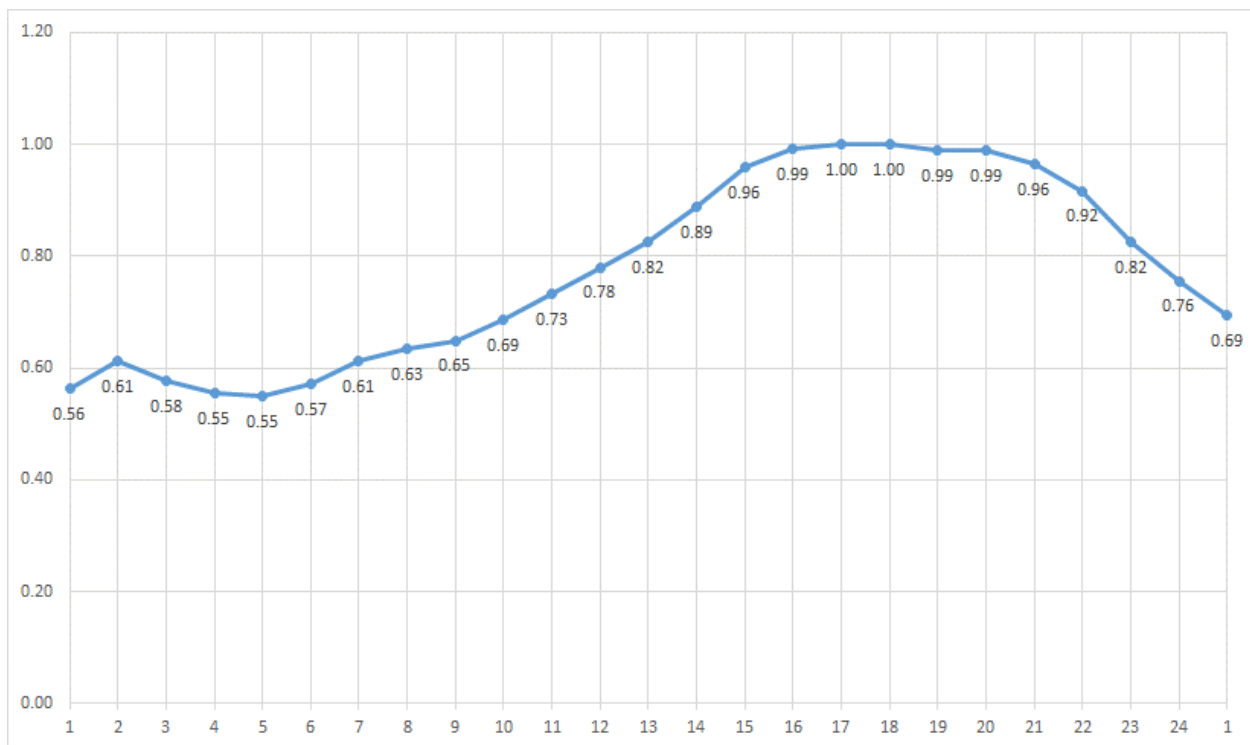

3.2.9.3.4 Western LA Basin LCR Sub-area Requirement

Table 3.2-71 identifies the sub-area LCR requirements. The LCR requirement for Category P6 contingency is 3943 MW. The 2025 LCR need is higher than 2024 LCR need due to CEC and SCE reallocation of substation loads resulting in a higher amount in Western LA Basin.

Table 3.2-71 Western LA Basin LCR Sub-area Requirements

Year	Limit	Category	Limiting Facility	Contingency	LCR (MW) (Deficiency)
2025	First Limit	P6	Mesa-Laguna Bell 230 kV	Mesa-La Fresa 230 kV, followed by Mesa-Lighthipe 230 kV line or vice versa	3943

3.2.9.3.5 Effectiveness factors:

See Attachment B - Table titled [LA Basin](#).

For other helpful procurement information please read procedure 2210Z Effectiveness Factors under 7630 (G-219Z) posted at: <http://www.caiso.com/Documents/2210Z.pdf>

There are other combinations of contingencies in the area that could overload a significant number of 230 kV lines in this sub-area have less LCR need. As such, anyone of them (combination of contingencies) could become binding for any given set of procured resources. As a result, these effectiveness factors may not be the best indicator towards informed procurement.

3.2.9.4 West of Devers Sub-area

West of Devers is a Sub-area of the LA Basin LCR Area.

There are no local capacity requirements due to implementation of the Mesa Loop-in as well as West of Devers reconductoring projects.

3.2.9.5 Valley-Devers Sub-area

Valley-Devers is a Sub-area of the LA Basin LCR Area.

There are no local capacity requirements due to implementation of the Colorado River-Delaney 500 kV line project.

3.2.9.6 Valley Sub-area

Valley is a Sub-area of the LA Basin LCR Area.

There are no local capacity requirements due to implementation of the Colorado River-Delaney 500 kV line project.

3.2.9.7 Eastern LA Basin Sub-area

Eastern LA Basin is a Sub-area of the LA Basin LCR Area.

3.2.9.7.1 Eastern LA Basin LCR Sub-area Diagram

Please refer to Figure 3.2-81 above.

3.2.9.7.2 Eastern LA Basin LCR Sub-area Load and Resources

Table 3.2-72 provides the forecast load and resources in Eastern LA Basin LCR sub-area in 2025. The list of generators within the LCR sub-area are provided in Attachment A.

Table 3.2-72 Eastern LA Basin Sub-area 2025 Forecast Load and Resources

Load (MW)		Generation (MW)	Aug NQC	At Peak
Gross Load	8355	Market, Net Seller, Battery, Wind	2384	2384
AAEE	-273	MUNI	472	472
Behind the meter DG	-683	QF	83	83
Net Load	7399	LTPP Preferred Resources	0	0
Transmission Losses	111	Existing Demand Response	126	126
Pumps	20	Solar	9	9
Load + Losses + Pumps	7530	Total	3074	3074

3.2.9.7.3 Eastern LA Basin LCR Sub-area Hourly Profiles

Figure 3.2-84 illustrates the forecast 2025 profile for the summer peak day in the Eastern LA Basin LCR sub-area.

Figure 3.2-84 Eastern LA Basin LCR Sub-area 2025 Peak Day Forecast Profiles

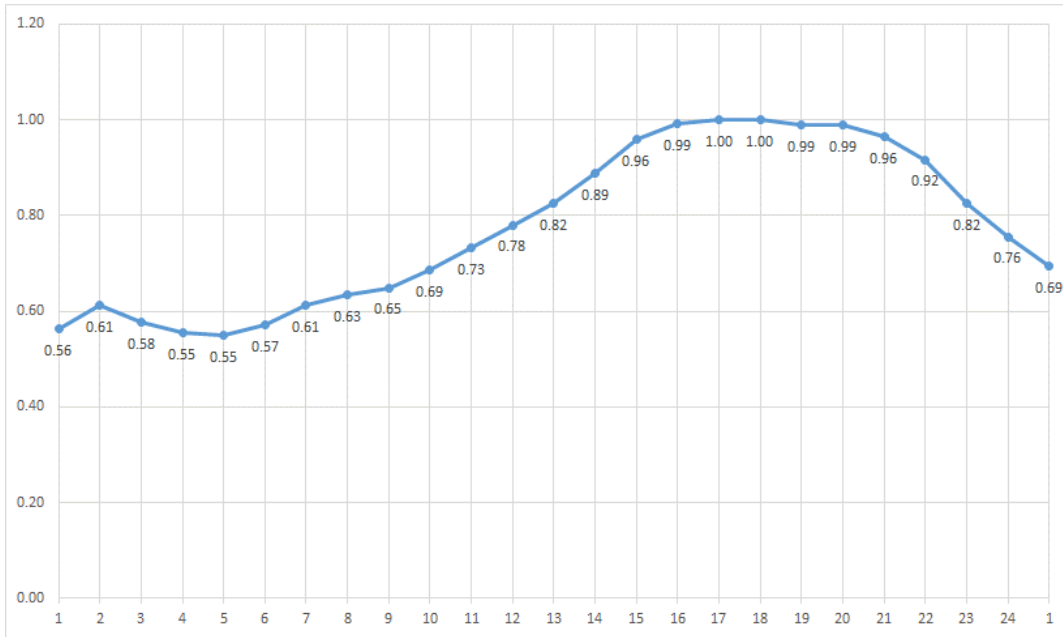

3.2.9.7.4 Eastern LA Basin LCR Sub-area Requirement

Table 3.2-73 identifies the sub-area LCR requirements. The LCR requirement for Category P1+P7 contingency is 2477 MW. The 2025 LCR need for the Eastern LA Basin is lower due than the 2024 local capacity need due to lower import levels from the Southwest because of base-load generation retirement in Arizona. Lower import level results in less line voltage drop, lessening voltage stability concern. As well as higher LCR level in the Western LA Basin results in lower voltage drop, lessening voltage stability concern.

Table 3.2-73 Eastern LA Basin LCR Sub-area Requirements

Year	Limit	Category	Limiting Facility	Contingency	LCR (MW) (Deficiency)
2025	First Limit	P1+P7	Post transient voltage stability	Alberhill-Serrano 500 kV, followed by Devers-Red Bluff #1 and #2 500 kV	2366

3.2.9.7.5 Effectiveness factors:

All units within the Eastern LA Basin sub-area have the same effectiveness factor.

For most helpful procurement information please read procedure 2210Z Effectiveness Factors under 7630 (G-219Z) posted at: <http://www.caiso.com/Documents/2210Z.pdf>

3.2.9.8 LA Basin Overall

3.2.9.8.1 LA Basin LCR Sub-area Hourly Profiles

Figure 3.2-85 illustrates the forecast 2025 profile for the summer peak day in the LA Basin LCR area.

Figure 3.2-85 LA Basin LCR area 2025 Peak Day Forecast Profiles

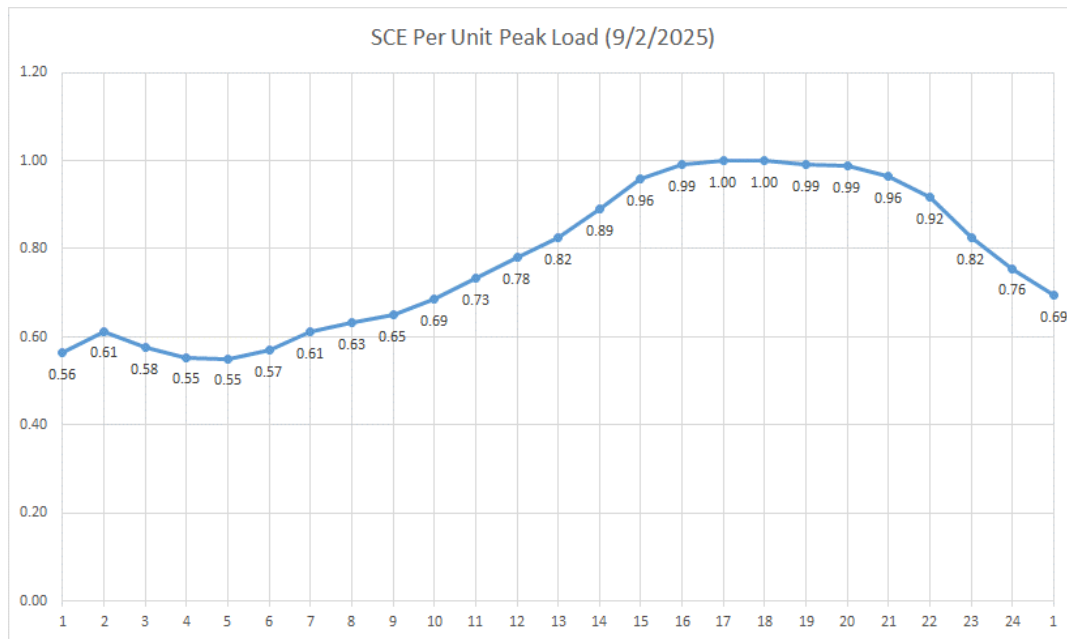

3.2.9.8.2 LA Basin LCR area Requirement

Table 3.2-74 identifies the area requirements. The LCR requirement is driven by the sum of the LCR needs for the Western LA Basin and Eastern LA Basin sub-areas, at 6309 MW. Followed closely is the LCR need due to a Category P3 contingency of G-1 of TDM power plant, system readjustment, followed by an outage on the Imperial Valley – North Gila 500 kV line.

Table 3.2-74 LA Basin LCR area Requirements

Year	Limit	Category	Limiting Facility	Contingency	LCR (MW) (Deficiency)
2025	First Limit	N/A	Sum of Western and Eastern.		6309
2025	Second Limit	P3	EI Centro 230/92 kV	TDM, system readjustment and Imperial Valley–North Gila 500 kV line	6281

3.2.9.8.3 Effectiveness factors:

See Attachment B - Table titled [LA Basin](#).

For other helpful procurement information please read procedure 2210Z Effectiveness Factors under 7570 (T-144Z), 7580 (T-139Z), 7590 (T-137Z, 6750) and 7680 (T-130Z) posted at: <http://www.caiso.com/Documents/2210Z.pdf>

There are other combinations of contingencies in the area that could overload a significant number of 230 kV lines in this sub-area have less LCR need. As such, anyone of them (combination of contingencies) could become binding for any given set of procured resources. As a result, these effectiveness factors may not be the best indicator towards informed procurement.

3.2.9.8.4 Changes compared to 2024 LCT study

Compared with 2024, the load forecast is lower by 469 MW. The LCR need has increases by 49 MW mostly due to CEC and SCE reallocation of substation loads resulting in a higher amount in Western LA Basin .

3.2.10 San Diego-Imperial Valley Area

3.2.10.1 *Area Definition:*

The transmission tie lines forming a boundary around the Greater San Diego-Imperial Valley area include:

- Imperial Valley – North Gila 500 kV Line
- Otay Mesa – Tijuana 230 kV Line
- San Onofre - San Luis Rey #1 230 kV Line
- San Onofre - San Luis Rey #2 230 kV Line
- San Onofre - San Luis Rey #3 230 kV Line
- San Onofre – Talega 230 kV Line
- San Onofre – Capistrano 230 kV Line
- Imperial Valley – El Centro 230 kV Line
- Imperial Valley – La Rosita 230 kV Line

The substations that delineate the Greater San Diego-Imperial Valley area are:

- Imperial Valley is in North Gila is out
- Otay Mesa is in Tijuana is out
- San Onofre is out San Luis Rey is in
- San Onofre is out San Luis Rey is in

San Onofre is out San Luis Rey is in
 San Onofre is out Talega is in
 San Onofre is out Capistrano is in
 Imperial Valley is in El Centro is out
 Imperial Valley is in La Rosita is out

3.2.10.1.1 San Diego-Imperial Valley LCR Area Diagram

Figure 3.2-86 San Diego-Imperial Valley LCR Area

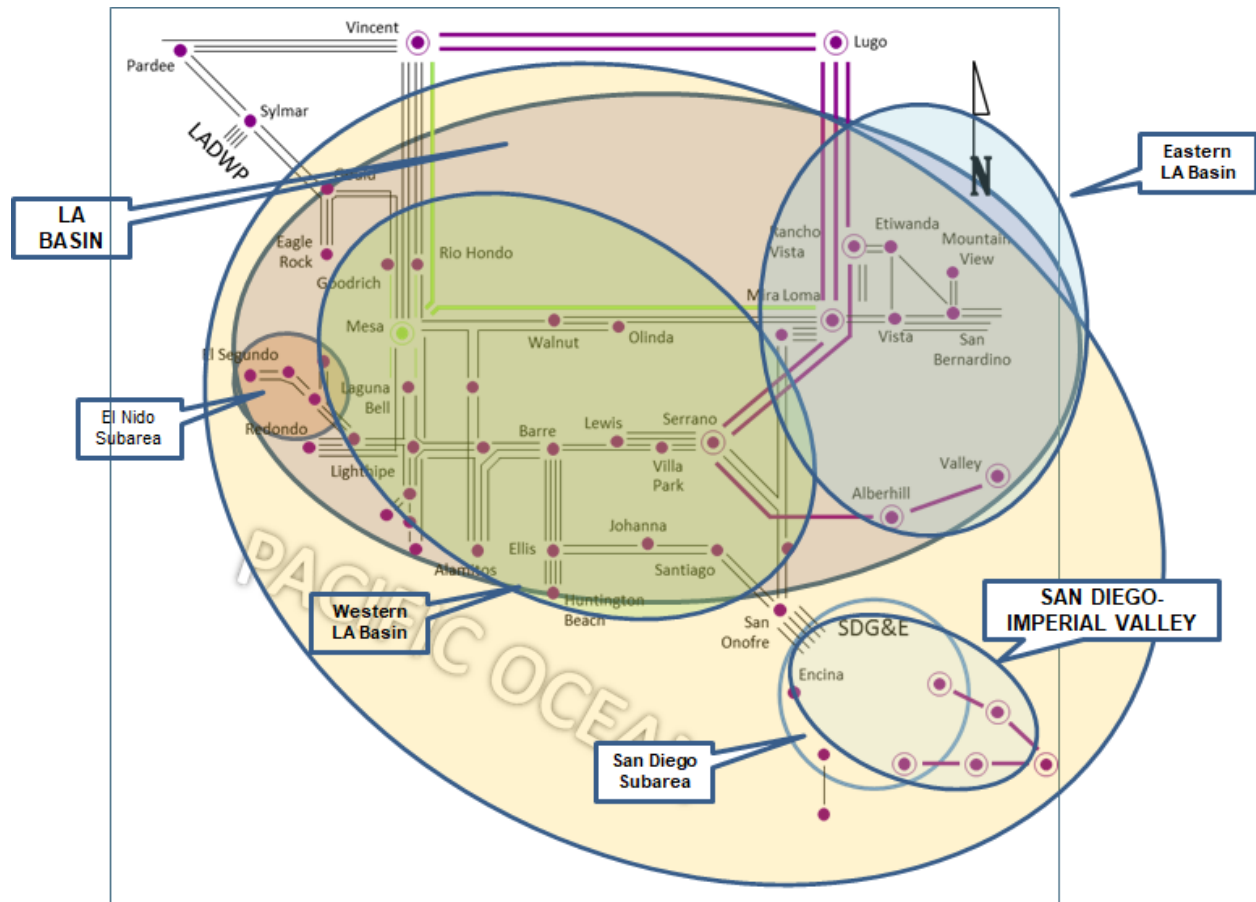

3.2.10.1.2 San Diego-Imperial Valley LCR Area Load and Resources

Table 3.2-75 provides the forecast load and resources in the San Diego-Imperial Valley LCR area in 2025. The list of generators within the LCR area are provided in Attachment A.

In year 2025 the estimated time of local area peak is 8:00 PM on September 3, 2025 per the CEC hourly demand forecast.⁹

At the local area peak time the estimated, ISO metered solar output is 0.00%.

⁹ https://ww2.energy.ca.gov/2019_energy/policy/documents/Demand_2020-2030_revised_forecast_hourly.php

If required, all non-solar technology type resources are dispatched at NQC.

Table 3.2-75 San Diego-Imperial Valley LCR Area 2025 Forecast Load and Resources

Load (MW)		Generation (MW)	Aug NQC	At Peak
Gross Load	4618	Market, Net Seller, Battery, Wind	4431	4431
AAEE	-66	Solar	378	0
Behind the meter DG	0	QF	2	2
Net Load	4552	LTPP Preferred Resources	0	0
Transmission Losses	123	Existing Demand Response	7	7
Pumps	0	Mothballed	0	0
Load + Losses + Pumps	4675	Total	4818	4440

3.2.10.1.3 Approved transmission and resource projects modeled:

Ocean Ranch 69 kV substation

Mesa Height TL600 Loop-in

TL6906 Mesa Rim rearrangement

Upgrade Bernardo - Rancho Carmel 69 kV line

Suncrest SVC project

By-passing 500 kV series capacitor banks on the Southwest Powerlink and Sunrise Powerlink lines

Generation retirements at Encina, North Island, Division Naval Station and Otay Landfill

Miramar Energy Storage Project (30 MW)

Storage projects at Melrose (40 MW)

Avocado Energy Storage Project (40 MW)

Second San Marcos–Escondido 69 kV line

Reconductor of Stuart Tap–Las Pulgas 69 kV line (TL690E)

Second Poway–Pomerado 69 kV line

Artesian 230 kV expansion with 69 kV upgrade

South Orange County Reliability Enhancement

Imperial Valley-EI Centro 230 kV (“S”) line upgrade

3.2.10.2 El Cajon Sub-area

El Cajon is a Sub-area in the San Diego-Imperial Valley LCR Area.

3.2.10.2.1 El Cajon LCR Sub-area Diagram

Figure 3.2-87 El Cajon LCR Sub-area

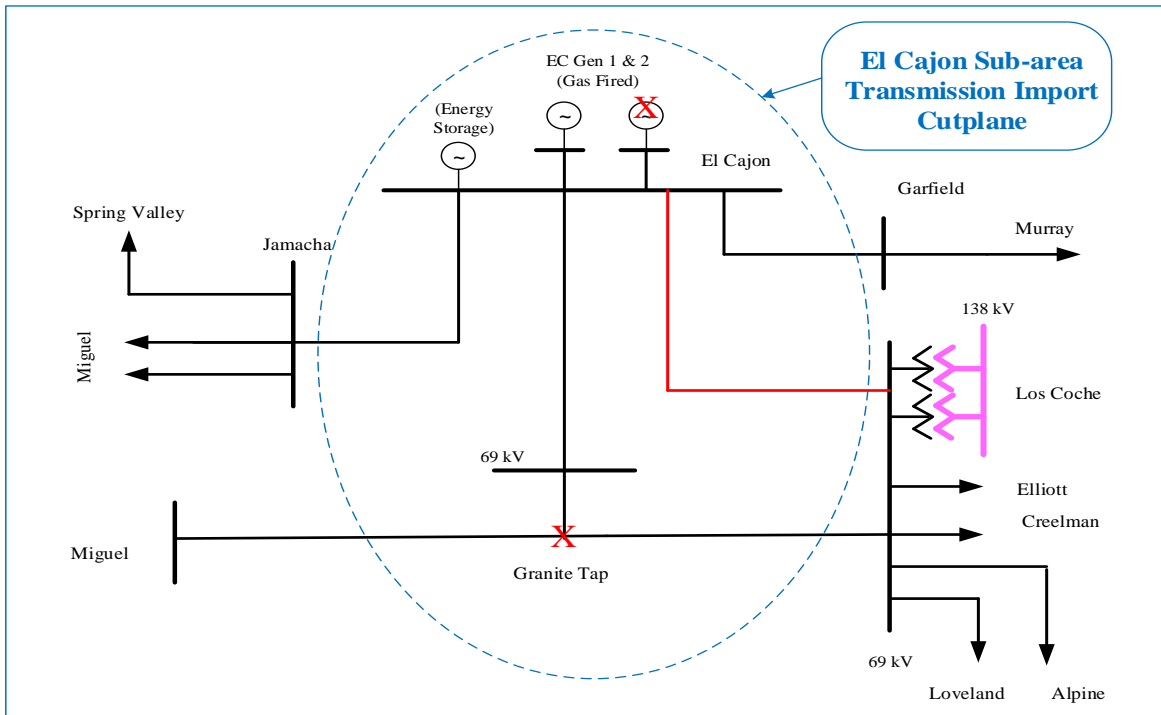

3.2.10.2.2 El Cajon LCR Sub-area Load and Resources

Table 3.2-76 provides the forecast load and resources in El Cajon LCR sub-area in 2025. The list of generators within the LCR sub-area are provided in Attachment A.

Table 3.2-76 El Cajon LCR Sub-area 2025 Forecast Load and Resources

Load (MW)		Generation (MW)	Aug NQC	At Peak
Gross Load	172	Market, Net Seller, Battery	101	101
AAEE	-3	MUNI	0	0
Behind the meter DG	0	QF	0	0
Net Load	169	LTPP Preferred Resources	0	0
Transmission Losses	3	Demand Response	0	0
Pumps	0	Mothballed	0	0
Load + Losses + Pumps	172	Total	101	101

3.2.10.2.3 El Cajon LCR Sub-area Hourly Profiles

Figure 3.2-88 illustrates the 2025 annual load forecast profile in the El Cajon LCR sub-area and the Category P1 (L-1 Contingency) transmission capability without gas generation. Figure 3.2-89 illustrates the 2025 daily load profile forecast for the peak day for the sub-area along with the load serving capabilities. The illustration also includes an estimate of 49/441 MW/MWh energy storage that could be added in this local area from charging restriction perspective, which includes the existing 7.5 MW of energy storage at El Cajon, in order to displace the LCR requirement for gas generation, assuming the biggest energy storage unit is 4/36 MW/MWh.

Figure 3.2-88 El Cajon LCR Sub-area 2025 Annual Load Forecast Profiles

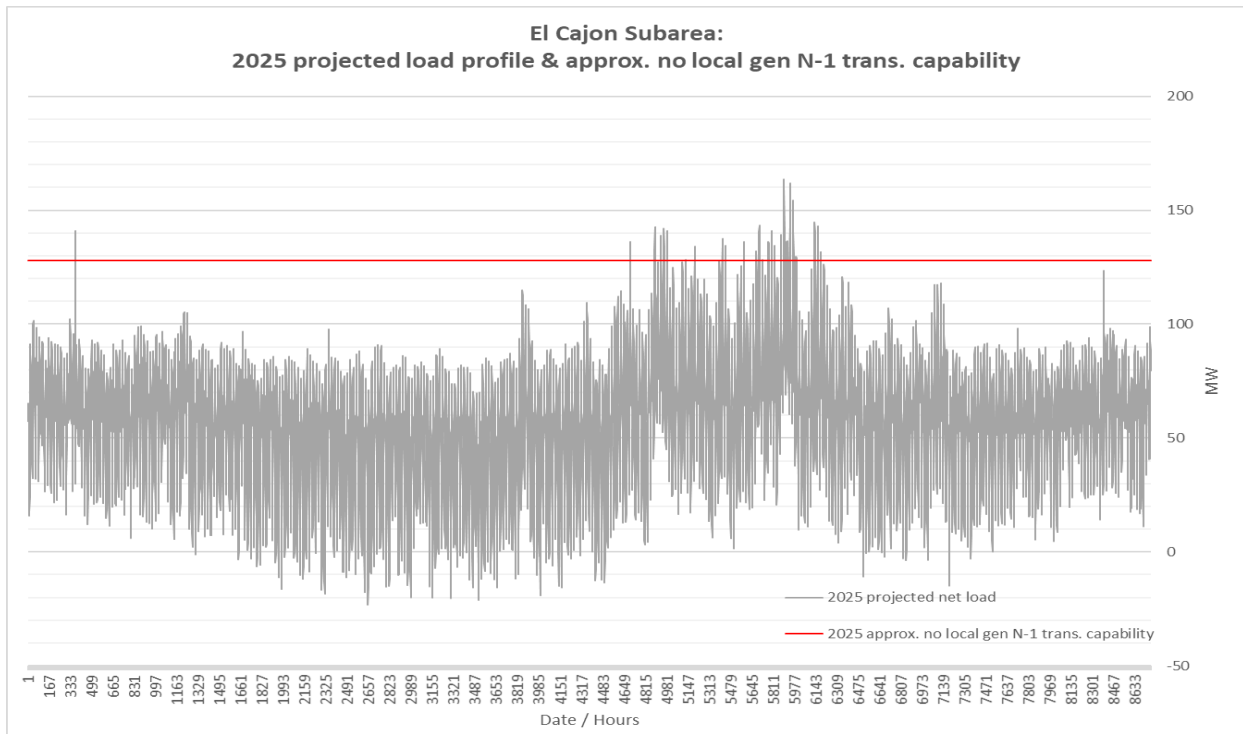
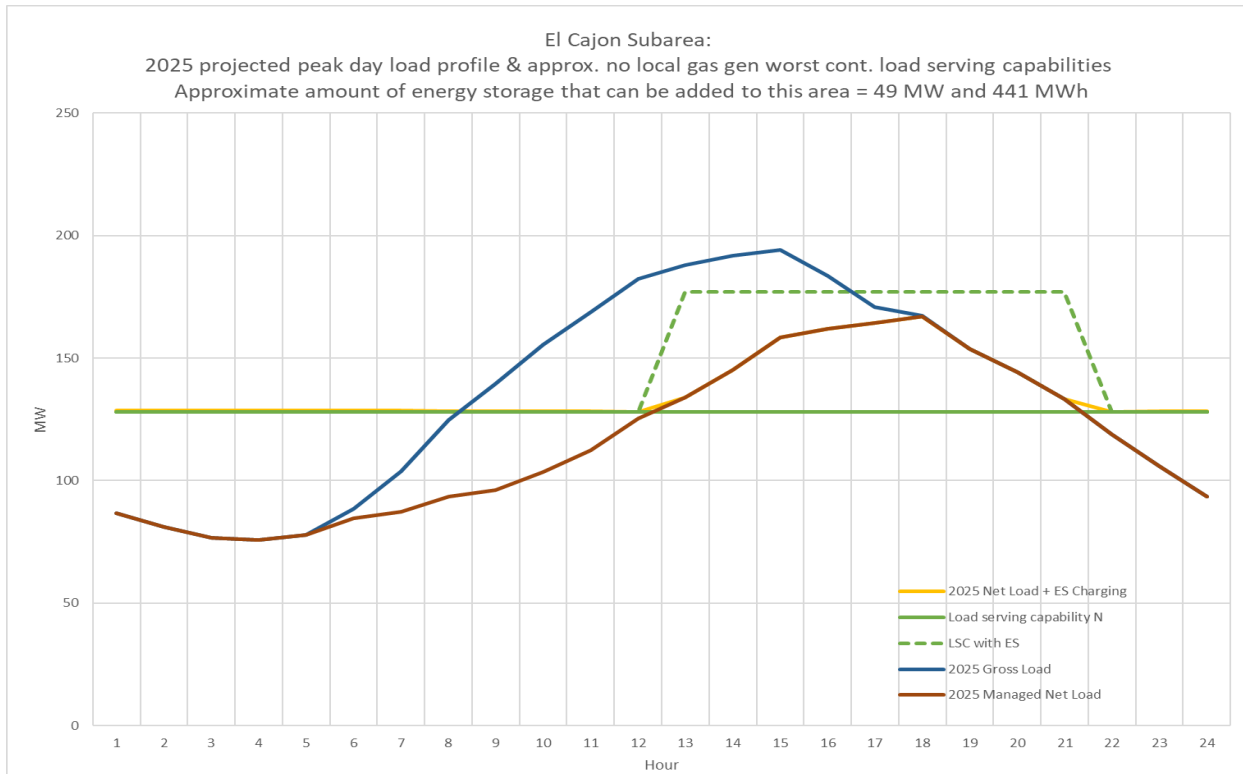

Figure 3.2-89 El Cajon LCR Sub-area 2025 Peak Day Forecast Profiles



3.2.10.2.4 El Cajon LCR Sub-area Requirement

Table 3.2-77 identifies the sub-area LCR requirements. The LCR requirement for Category P3 contingency is 99 MW.

Table 3.2-77 El Cajon LCR Sub-area Requirements

Year	Limit	Category	Limiting Facility	Contingency	LCR (MW) (Deficiency)
2025	First Limit	P3	El Cajon-Los Coches 69 kV (TL631)	El Cajon unit out of service followed by Miguel-Granite-Los Coches 69 kV line	99

3.2.10.2.5 Effectiveness factors:

All units within the El Cajon sub-area have the same effectiveness factor.

3.2.10.3 Esco Sub-area

Esco sub-area has been eliminated due to change in LCR criteria.

3.2.10.4 Pala Inner Sub-area

Pala Inner sub-area has been eliminated due to change in LCR criteria.

3.2.10.5 **Pala Outer Sub-area**

Pala Outer sub-area has been eliminated due to change in LCR criteria.

3.2.10.6 **Border Sub-area**

Border is a Sub-area of the San Diego-Imperial Valley LCR Area.

3.2.10.6.1 **Border LCR Sub-area Diagram**

Figure 3.2-90 Border LCR Sub-area

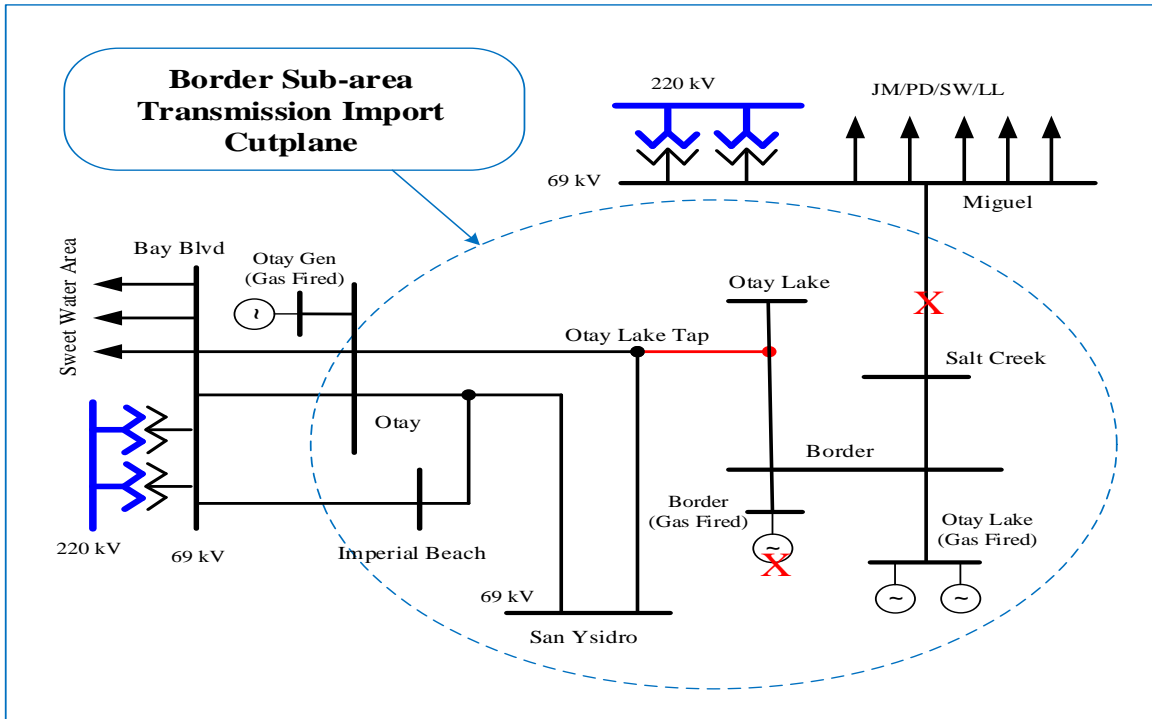

3.2.10.6.2 **Border LCR Sub-area Load and Resources**

Table 3.2-78 provides the forecast load and resources in Border LCR sub-area in 2025. The list of generators within the LCR sub-area are provided in Attachment A.

Table 3.2-78 Border Sub-area 2025 Forecast Load and Resources

Load (MW)		Generation (MW)	Aug NQC	At Peak
Gross Load	166	Market, Net Seller, Battery	143	143
AAEE	-8	Solar	0	0
Behind the meter DG	0	QF	0	0
Net Load	158	LTPP Preferred Resources	0	0
Transmission Losses	2	Demand Response	0	0

Pumps	0	Mothballed	0	0
Load + Losses + Pumps	160	Total	143	143

3.2.10.6.3 Border LCR Sub-area Hourly Profiles

Figure 3.2-91 illustrates the 2025 annual load forecast profile in the Border LCR sub-area and the Category P1 (L-1 Contingency) transmission capability without gas generation. Figure 3.2-92 illustrates the 2025 daily load forecast profile for the peak day in the sub-area along with the load serving capabilities. The illustration also includes an estimate of 156/775 MW/MWh energy storage that could be added in this local area from charging restriction perspective. In addition, it is estimated that 52/260 MW/MWh energy storage are required to displace the LCR requirement for gas generation, assuming the biggest energy storage unit is 26/130 MW/MWh in the Border LCR sub-area.

Figure 3.2-91 Border LCR Sub-area 2025 Annual Load Forecast Profiles

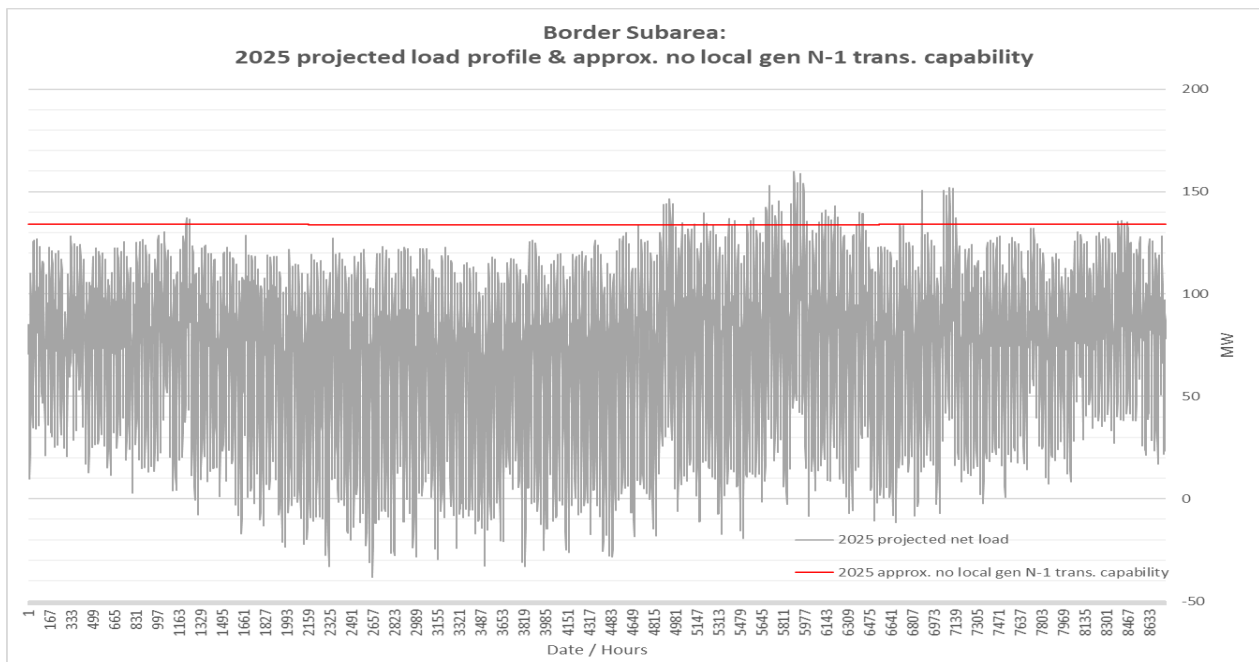
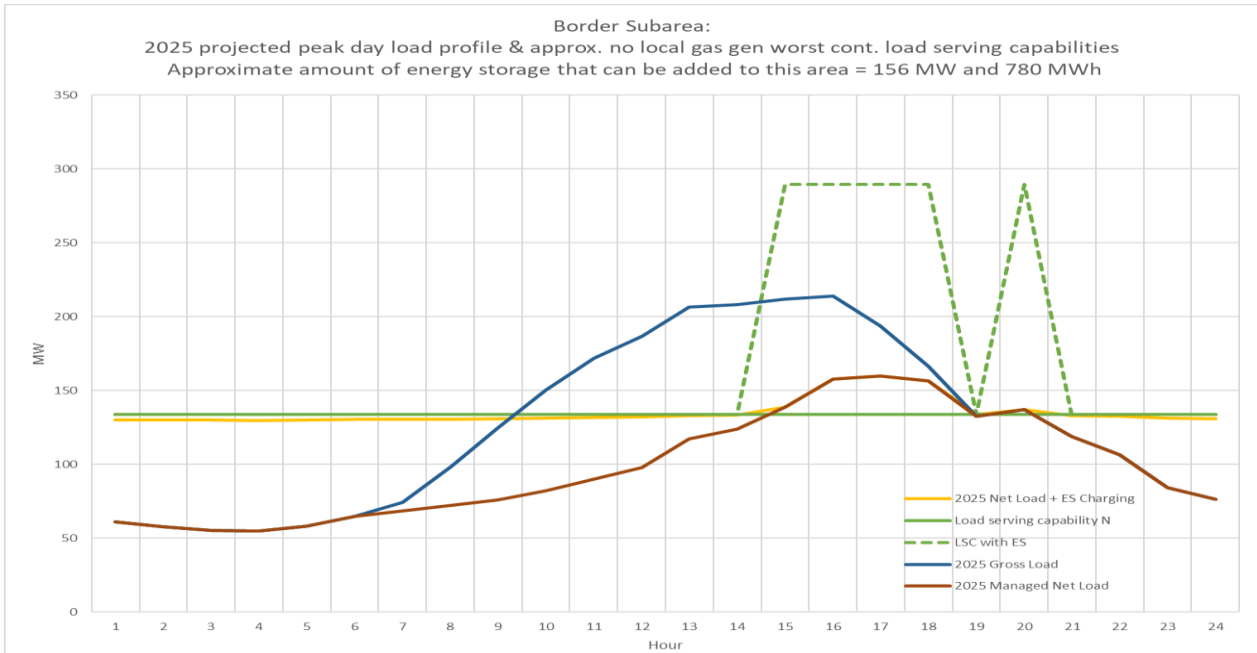

Figure 3.2-92 Border LCR Sub-area 2025 Peak Day Forecast Profiles



3.2.10.6.4 Border LCR Sub-area Requirement

Table 3.2-79 identifies the sub-area requirements. The LCR requirement for Category P3 contingency is 62 MW.

Table 3.2-79 Border 2025 LCR Sub-area Requirements

Year	Limit	Category	Limiting Facility	Contingency	LCR (MW) (Deficiency)
2025	First Limit	P3	Otay – Otay Lake Tap 69 kV (TL649)	Border unit out of service followed by the outage of Miguel-Salt Creek 69 kV #1	62

3.2.10.6.5 Effectiveness factors:

All units within the Border sub-area have the same effectiveness factor.

3.2.10.7 San Diego Sub-area

San Diego is a Sub-area of the San Diego-Imperial Valley LCR Area.

3.2.10.7.1 San Diego LCR Sub-area Diagram

Please refer to Figure 3.2-86 above.

3.2.10.7.2 San Diego LCR Sub-area Load and Resources

Table 3.2-80 provides the forecast load and resources in San Diego LCR sub-area in 2025. The list of generators within the LCR sub-area are provided in Attachment A.

Table 3.2-80 San Diego Sub-area 2025 Forecast Load and Resources

Load (MW)		Generation (MW)	Aug NQC	At Peak
Gross Load	4618	Market, Net Seller, Battery, Wind	2987	2987
AAEE	-66	Solar	29	0
Behind the meter DG	0	QF	2	2
Net Load	4552	LTPP Preferred Resources	0	0
Transmission Losses	123	Existing Demand Response	7	7
Pumps	0	Mothballed	0	0
Load + Losses + Pumps	4675	Total	3025	2996

3.2.10.7.3 San Diego LCR Sub-area Hourly Profiles

Figure 3.2-93 illustrates the forecast 2025 profile for the summer peak day for the San Diego LCR sub-area. The plot is from the CEC 2020-2030 Revised Forecast’s hourly forecast.¹⁰

Figure 3.2-93 San Diego LCR Sub-area 2025 Peak Day Forecast Profiles

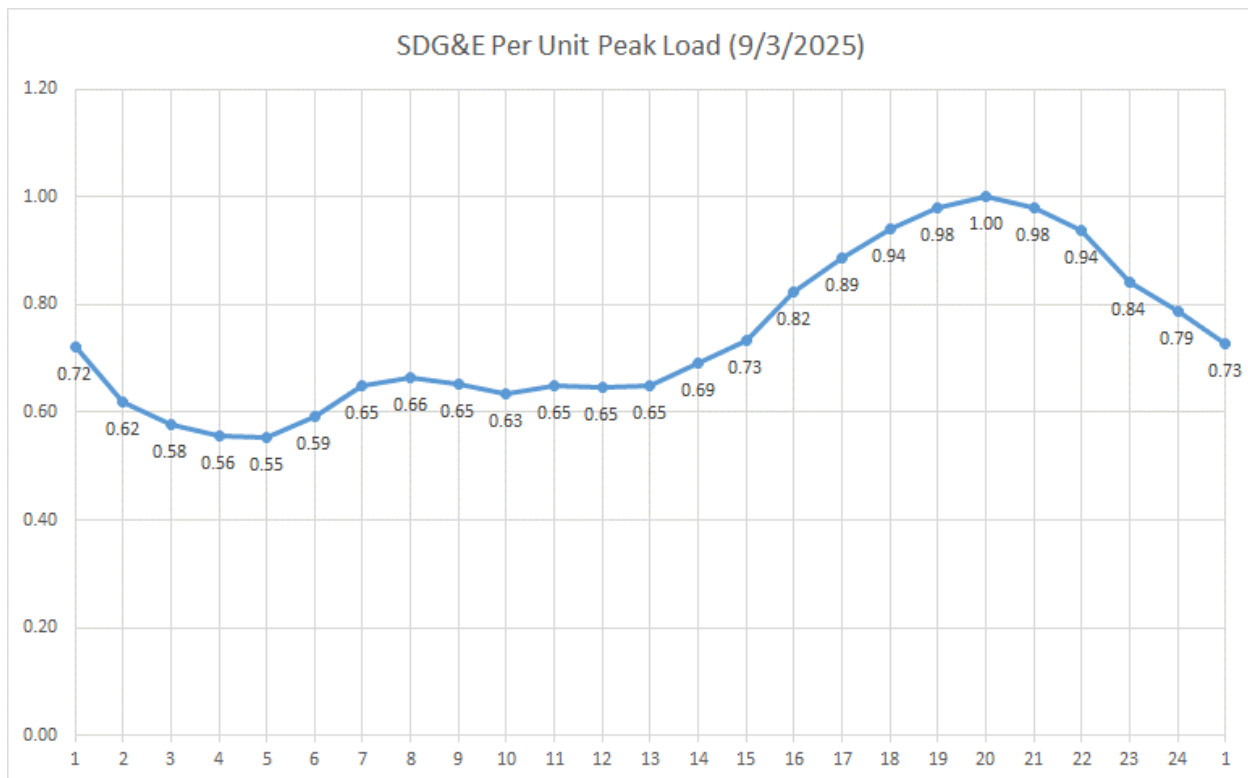

¹⁰ <https://efiling.energy.ca.gov/GetDocument.aspx?tn=231565&DocumentContentId=63386>

3.2.10.7.4 San Diego LCR Sub-area Requirement

Table 3.2-81 identifies the sub-area LCR requirements. The LCR requirement for Category P6 contingency is 2791 MW.

Table 3.2-81 San Diego LCR Sub-area Requirements

Year	Limit	Category	Limiting Facility	Contingency	LCR (MW) (Deficiency)
2025	First Limit	P6	Remaining Sycamore – Suncrest 230 kV	Eco – Miguel 500 kV, system readjustment followed by one of the Sycamore – Suncrest 230 kV lines	2791

3.2.10.7.5 Effectiveness factors:

See Attachment B - Table titled [San Diego](#).

For other helpful procurement information please read procedure 2210Z Effectiveness Factors under 7820 (T-132Z) posted at: <http://www.caiso.com/Documents/2210Z.pdf>

3.2.10.8 San Diego-Imperial Valley Overall

3.2.10.8.1 San Diego-Imperial Valley LCR area Hourly Profiles

Same as San Diego sub-area see section above.

3.2.10.8.2 San Diego-Imperial Valley LCR area Requirement

Table 3.2-82 identifies the area LCR requirements. The LCR requirement for Category P6 contingency is 3557 MW.

Table 3.2-82 San Diego-Imperial Valley LCR area Requirements

Year	Limit	Category	Limiting Facility	Contingency	LCR (MW) (Deficiency)
2025	First Limit	P3	El Centro 230/92 kV	TDM power plant, system readjustment and Imperial Valley–North Gila 500 kV line	3557

3.2.10.8.3 Effectiveness factors:

See Attachment B - Table titled [San Diego](#).

For other helpful procurement information please read procedure 2210Z Effectiveness Factors under 7820 (T-132Z) posted at: <http://www.caiso.com/Documents/2210Z.pdf>

3.2.10.8.4 Changes compared to 2024 LCT Study

Compared with the 2024 the demand forecast is lower by 130 MW. The overall LCR need for the San Diego – Imperial Valley area has decreased by 468 MW, due to decrease in load forecast and largely attributed to modeling of projected new resources (i.e., battery energy storage system) at effective location.

3.2.11 Valley Electric Area

Valley Electric Association LCR area has been eliminated on the basis of the following:

No generation exists in this area

No category B issues were observed in this area

Category C and beyond –

- No common-mode N-2 issues were observed
- No issues were observed for category B outage followed by a common-mode N-2 outage
- All the N-1-1 issues that were observed can either be mitigated by the existing UVLS or by an operating procedure

Attachment A – List of physical resources by PTO, local area and market ID

PTO	MKT/SCHED RESOURCE ID	BUS #	BUS NAME	kV	NQC	UNIT ID	LCR AREA NAME	LCR SUB-AREA NAME	NQC Comments	CAISO Tag
PG&E	ALMEGT_1_UNIT 1	38118	ALMDACT1	13.8	23.40	1	Bay Area	Oakland		MUNI
PG&E	ALMEGT_1_UNIT 2	38119	ALMDACT2	13.8	23.50	1	Bay Area	Oakland		MUNI
PG&E	BANKPP_2_NSPIN	38820	DELTA A	13.2	11.55	1	Bay Area	Contra Costa	Pumps	MUNI
PG&E	BANKPP_2_NSPIN	38820	DELTA A	13.2	11.55	2	Bay Area	Contra Costa	Pumps	MUNI
PG&E	BANKPP_2_NSPIN	38820	DELTA A	13.2	11.55	3	Bay Area	Contra Costa	Pumps	MUNI
PG&E	BANKPP_2_NSPIN	38815	DELTA B	13.2	11.55	4	Bay Area	Contra Costa	Pumps	MUNI
PG&E	BANKPP_2_NSPIN	38815	DELTA B	13.2	11.55	5	Bay Area	Contra Costa	Pumps	MUNI
PG&E	BANKPP_2_NSPIN	38770	DELTA C	13.2	11.55	6	Bay Area	Contra Costa	Pumps	MUNI
PG&E	BANKPP_2_NSPIN	38770	DELTA C	13.2	11.55	7	Bay Area	Contra Costa	Pumps	MUNI
PG&E	BANKPP_2_NSPIN	38765	DELTA D	13.2	11.55	8	Bay Area	Contra Costa	Pumps	MUNI
PG&E	BANKPP_2_NSPIN	38765	DELTA D	13.2	11.55	9	Bay Area	Contra Costa	Pumps	MUNI
PG&E	BANKPP_2_NSPIN	38760	DELTA E	13.2	11.55	10	Bay Area	Contra Costa	Pumps	MUNI
PG&E	BANKPP_2_NSPIN	38760	DELTA E	13.2	11.55	11	Bay Area	Contra Costa	Pumps	MUNI
PG&E	BRDSLD_2_HIWIND	32172	HIGHWINDS	34.5	42.93	1	Bay Area	Contra Costa	Aug NQC	Wind
PG&E	BRDSLD_2_MTZUM2	32179	MNTZUMA2	0.69	20.72	1	Bay Area	Contra Costa	Aug NQC	Wind
PG&E	BRDSLD_2_MTZUMA	32188	HIGHWIND3	0.69	9.75	1	Bay Area	Contra Costa	Aug NQC	Wind
PG&E	BRDSLD_2_SHILO1	32176	SHILOH	34.5	39.75	1	Bay Area	Contra Costa	Aug NQC	Wind
PG&E	BRDSLD_2_SHILO2	32177	SHILOH 2	34.5	39.75	1	Bay Area	Contra Costa	Aug NQC	Wind
PG&E	BRDSLD_2_SHLO3A	32191	SHILOH3	0.58	27.16	1	Bay Area	Contra Costa	Aug NQC	Wind
PG&E	BRDSLD_2_SHLO3B	32194	SHILOH4	0.58	26.50	1	Bay Area	Contra Costa	Aug NQC	Wind
PG&E	CALPIN_1_AGNEW	35860	OLS-AGNE	9.11	28.56	1	Bay Area	San Jose, South Bay-Moss Landing	Aug NQC	Market
PG&E	CAYTNO_2_VASCO	30531	0162-WD	230	4.30	FW	Bay Area	Contra Costa	Aug NQC	Market
PG&E	CLRMTK_1_QF				0.00		Bay Area	Oakland	Not modeled	QF/Selfgen
PG&E	COCOPP_2_CTG1	33188	MARSHCT1	16.4	200.30	1	Bay Area	Contra Costa	Aug NQC	Market

Attachment A - List of physical resources by PTO, local area and market ID

PG&E	COCOPP_2_CTG2	33188	MARSHCT2	16.4	199.70	2	Bay Area	Contra Costa	Aug NQC	Market
PG&E	COCOPP_2_CTG3	33189	MARSHCT3	16.4	199.00	3	Bay Area	Contra Costa	Aug NQC	Market
PG&E	COCOPP_2_CTG4	33189	MARSHCT4	16.4	199.70	4	Bay Area	Contra Costa	Aug NQC	Market
PG&E	COCOSB_6_SOLAR				0.00		Bay Area	Contra Costa	Not modeled Energy Only	Solar
PG&E	CROKET_7_UNIT	32900	CRCKTCOG	18	220.00	1	Bay Area	Pittsburg	Aug NQC	QF/Selfgen
PG&E	CSCCOG_1_UNIT 1	36859	Laf300	12	3.00	1	Bay Area	San Jose, South Bay-Moss Landing		MUNI
PG&E	CSCCOG_1_UNIT 1	36859	Laf300	12	3.00	2	Bay Area	San Jose, South Bay-Moss Landing		MUNI
PG&E	CSCGNR_1_UNIT 1	36858	Gia100	13.8	24.00	1	Bay Area	San Jose, South Bay-Moss Landing		MUNI
PG&E	CSCGNR_1_UNIT 2	36895	Gia200	13.8	24.00	2	Bay Area	San Jose, South Bay-Moss Landing		MUNI
PG&E	CUMBIA_1_SOLAR	33102	COLUMBIA	0.38	7.79	1	Bay Area	Pittsburg	Aug NQC	Solar
PG&E	DELTA_2_PL1X4	33108	DEC CTG1	18	181.13	1	Bay Area	Pittsburg	Aug NQC	Market
PG&E	DELTA_2_PL1X4	33109	DEC CTG2	18	181.13	1	Bay Area	Pittsburg	Aug NQC	Market
PG&E	DELTA_2_PL1X4	33110	DEC CTG3	18	181.13	1	Bay Area	Pittsburg	Aug NQC	Market
PG&E	DELTA_2_PL1X4	33107	DEC STG1	24	269.60	1	Bay Area	Pittsburg	Aug NQC	Market
PG&E	DIXNLD_1_LNDFL				1.02		Bay Area		Not modeled Aug NQC	Market
PG&E	DUANE_1_PL1X3	36865	DVRaST3	13.8	48.36	1	Bay Area	San Jose, South Bay-Moss Landing		MUNI
PG&E	DUANE_1_PL1X3	36863	DVRaGT1	13.8	49.72	1	Bay Area	San Jose, South Bay-Moss Landing		MUNI
PG&E	DUANE_1_PL1X3	36864	DVRbGT2	13.8	49.72	1	Bay Area	San Jose, South Bay-Moss Landing		MUNI
PG&E	GATWAY_2_PL1X3	33119	GATEWAY2	18	181.50	1	Bay Area	Contra Costa	Aug NQC	Market
PG&E	GATWAY_2_PL1X3	33120	GATEWAY3	18	181.50	1	Bay Area	Contra Costa	Aug NQC	Market
PG&E	GATWAY_2_PL1X3	33118	GATEWAY1	18	191.69	1	Bay Area	Contra Costa	Aug NQC	Market
PG&E	GILROY_1_UNIT	35850	GLRY COG	13.8	69.00	1	Bay Area	Llagas, South Bay-Moss Landing	Aug NQC	Market
PG&E	GILROY_1_UNIT	35850	GLRY COG	13.8	36.00	2	Bay Area	Llagas, South Bay-Moss Landing	Aug NQC	Market
PG&E	GILRPP_1_PL1X2	35851	GROYPKR1	13.8	47.60	1	Bay Area	Llagas, South Bay-Moss Landing	Aug NQC	Market
PG&E	GILRPP_1_PL1X2	35852	GROYPKR2	13.8	47.60	1	Bay Area	Llagas, South Bay-Moss Landing	Aug NQC	Market

Attachment A - List of physical resources by PTO, local area and market ID

PG&E	GILRPP_1_PL3X4	35853	GROYPKR3	13.8	46.20	1	Bay Area	Llagas, South Bay-Moss Landing	Aug NQC	Market
PG&E	GRZZLY_1_BERKLY	32741	HILLSIDE_12	12.47	23.47	1	Bay Area		Aug NQC	Net Seller
PG&E	KELSO_2_UNITS	33813	MARIPCT1	13.8	49.51	1	Bay Area	Contra Costa	Aug NQC	Market
PG&E	KELSO_2_UNITS	33815	MARIPCT2	13.8	49.51	2	Bay Area	Contra Costa	Aug NQC	Market
PG&E	KELSO_2_UNITS	33817	MARIPCT3	13.8	49.51	3	Bay Area	Contra Costa	Aug NQC	Market
PG&E	KELSO_2_UNITS	33819	MARIPCT4	13.8	49.51	4	Bay Area	Contra Costa	Aug NQC	Market
PG&E	KIRKER_7_KELCYN				3.21		Bay Area	Pittsburg	Not modeled	Market
PG&E	LAWRNC_7_SUNYVL				0.18		Bay Area		Not modeled Aug NQC	Market
PG&E	LECEF_1_UNITS	35854	LECEFGT1	13.8	47.81	1	Bay Area	San Jose, South Bay-Moss Landing	Aug NQC	Market
PG&E	LECEF_1_UNITS	35855	LECEFGT2	13.8	47.81	1	Bay Area	San Jose, South Bay-Moss Landing	Aug NQC	Market
PG&E	LECEF_1_UNITS	35856	LECEFGT3	13.8	47.81	1	Bay Area	San Jose, South Bay-Moss Landing	Aug NQC	Market
PG&E	LECEF_1_UNITS	35857	LECEFGT4	13.8	47.81	1	Bay Area	San Jose, South Bay-Moss Landing	Aug NQC	Market
PG&E	LECEF_1_UNITS	35858	LECEFST1	13.8	114.75	1	Bay Area	San Jose, South Bay-Moss Landing		Market
PG&E	LMBEPK_2_UNITA1	32173	LAMBGT1	13.8	47.50	1	Bay Area	Contra Costa	Aug NQC	Market
PG&E	LMBEPK_2_UNITA2	32174	GOOSEHGT	13.8	47.60	2	Bay Area	Contra Costa	Aug NQC	Market
PG&E	LMBEPK_2_UNITA3	32175	CREEDGT1	13.8	47.40	3	Bay Area	Contra Costa	Aug NQC	Market
PG&E	LMEC_1_PL1X3	33111	LMECCT2	18	160.07	1	Bay Area	Pittsburg	Aug NQC	Market
PG&E	LMEC_1_PL1X3	33112	LMECCT1	18	160.07	1	Bay Area	Pittsburg	Aug NQC	Market
PG&E	LMEC_1_PL1X3	33113	LMECST1	18	235.85	1	Bay Area	Pittsburg	Aug NQC	Market
PG&E	MARTIN_1_SUNSET				1.85		Bay Area		Not modeled Aug NQC	QF/Selfgen
PG&E	METCLF_1_QF				0.22		Bay Area		Not modeled Aug NQC	QF/Selfgen
PG&E	METEC_2_PL1X3	35881	MEC CTG1	18	178.43	1	Bay Area	South Bay-Moss Landing	Aug NQC	Market
PG&E	METEC_2_PL1X3	35882	MEC CTG2	18	178.43	1	Bay Area	South Bay-Moss Landing	Aug NQC	Market
PG&E	METEC_2_PL1X3	35883	MEC STG1	18	213.13	1	Bay Area	South Bay-Moss Landing	Aug NQC	Market
PG&E	MISSIX_1_QF				0.01		Bay Area		Not modeled Aug NQC	QF/Selfgen

Attachment A - List of physical resources by PTO, local area and market ID

PG&E	MLPTAS_7_QFUNTS				0.01		Bay Area	San Jose, South Bay-Moss Landing	Not modeled Aug NQC	QF/Selfgen
PG&E	MOSSLD_1_QF				0.00		Bay Area		Not modeled Aug NQC	Market
PG&E	MOSSLD_2_PSP1	36221	DUKMOSS1	18	163.20	1	Bay Area	South Bay-Moss Landing	78% starting 2021	Market
PG&E	MOSSLD_2_PSP1	36222	DUKMOSS2	18	163.20	1	Bay Area	South Bay-Moss Landing	78% starting 2021	Market
PG&E	MOSSLD_2_PSP1	36223	DUKMOSS3	18	183.60	1	Bay Area	South Bay-Moss Landing	78% starting 2021	Market
PG&E	MOSSLD_2_PSP2	36224	DUKMOSS4	18	163.20	1	Bay Area	South Bay-Moss Landing	78% starting 2021	Market
PG&E	MOSSLD_2_PSP2	36225	DUKMOSS5	18	163.20	1	Bay Area	South Bay-Moss Landing	78% starting 2021	Market
PG&E	MOSSLD_2_PSP2	36226	DUKMOSS6	18	183.60	1	Bay Area	South Bay-Moss Landing	78% starting 2021	Market
PG&E	NEWARK_1_QF				0.29		Bay Area		Not modeled Aug NQC	QF/Selfgen
PG&E	OAK C_1_EBMUD				1.50		Bay Area	Oakland	Not modeled Aug NQC	MUNI
PG&E	OAK C_7_UNIT 1	32901	OAKLND 1	13.8	55.00	1	Bay Area	Oakland		Market
PG&E	OAK C_7_UNIT 2	32902	OAKLND 2	13.8	55.00	1	Bay Area	Oakland		Market
PG&E	OAK C_7_UNIT 3	32903	OAKLND 3	13.8	55.00	1	Bay Area	Oakland		Market
PG&E	OAK L_1_GTG1				0.00		Bay Area	Oakland	Not modeled Energy Only	Market
PG&E	OXMTN_6_LNDFIL	33469	OX_MTN	4.16	1.45	1	Bay Area	Ames		Market
PG&E	OXMTN_6_LNDFIL	33469	OX_MTN	4.16	1.45	2	Bay Area	Ames		Market
PG&E	OXMTN_6_LNDFIL	33469	OX_MTN	4.16	1.45	3	Bay Area	Ames		Market
PG&E	OXMTN_6_LNDFIL	33469	OX_MTN	4.16	1.45	4	Bay Area	Ames		Market
PG&E	OXMTN_6_LNDFIL	33469	OX_MTN	4.16	1.45	5	Bay Area	Ames		Market
PG&E	OXMTN_6_LNDFIL	33469	OX_MTN	4.16	1.45	6	Bay Area	Ames		Market
PG&E	OXMTN_6_LNDFIL	33469	OX_MTN	4.16	1.45	7	Bay Area	Ames		Market
PG&E	PALALT_7_COBUG				4.50		Bay Area		Not modeled	MUNI
PG&E	RICHMN_1_CHVSR2				3.48		Bay Area		Not modeled Aug NQC	Solar
PG&E	RICHMN_1_SOLAR				0.82		Bay Area		Not modeled Aug NQC	Solar

Attachment A - List of physical resources by PTO, local area and market ID

PG&E	RICHMN_7_BAYENV				2.00		Bay Area		Not modeled Aug NQC	Market
PG&E	RUSCTY_2_UNITS	35304	RUSELCT1	15	187.12	1	Bay Area	Ames	No NQC - Pmax	Market
PG&E	RUSCTY_2_UNITS	35305	RUSELCT2	15	187.12	2	Bay Area	Ames	No NQC - Pmax	Market
PG&E	RUSCTY_2_UNITS	35306	RUSELST1	15	246.26	3	Bay Area	Ames	No NQC - Pmax	Market
PG&E	RVRVEW_1_UNITA1	33178	RVEC_GEN	13.8	47.60	1	Bay Area	Contra Costa	Aug NQC	Market
PG&E	SRINTL_6_UNIT	33468	SRI INTL	9.11	0.81	1	Bay Area		Aug NQC	QF/Selfgen
PG&E	STAUFF_1_UNIT	33139	STAUFER	9.11	0.01	1	Bay Area		Aug NQC	QF/Selfgen
PG&E	STOILS_1_UNITS	32921	CHEVGEN1	13.8	1.08	1	Bay Area	Pittsburg	Aug NQC	Market
PG&E	STOILS_1_UNITS	32922	CHEVGEN2	13.8	1.08	1	Bay Area	Pittsburg	Aug NQC	Market
PG&E	STOILS_1_UNITS	32923	CHEVGEN3	13.8	0.50	3	Bay Area	Pittsburg	Aug NQC	Market
PG&E	TIDWTR_2_UNITS	33151	FOSTER W	12.47	4.02	1	Bay Area	Pittsburg	Aug NQC	Net Seller
PG&E	TIDWTR_2_UNITS	33151	FOSTER W	12.47	4.02	2	Bay Area	Pittsburg	Aug NQC	Net Seller
PG&E	TIDWTR_2_UNITS	33151	FOSTER W	12.47	3.06	3	Bay Area	Pittsburg	Aug NQC	Net Seller
PG&E	UNCHEM_1_UNIT	32920	UNION CH	9.11	12.44	1	Bay Area	Pittsburg	Aug NQC	QF/Selfgen
PG&E	UNOCAL_1_UNITS	32910	UNOCAL	12	0.01	1	Bay Area	Pittsburg	Aug NQC	QF/Selfgen
PG&E	UNOCAL_1_UNITS	32910	UNOCAL	12	0.01	2	Bay Area	Pittsburg	Aug NQC	QF/Selfgen
PG&E	UNOCAL_1_UNITS	32910	UNOCAL	12	0.01	3	Bay Area	Pittsburg	Aug NQC	QF/Selfgen
PG&E	USWNR_2_SMUD	32169	SOLANOWP	21	27.08	1	Bay Area	Contra Costa	Aug NQC	Wind
PG&E	USWNR_2_SMUD2	32186	SOLANO	34.5	33.87	1	Bay Area	Contra Costa	Aug NQC	Wind
PG&E	USWNR_2_UNITS	32168	EXNCO	9.11	2.12	1	Bay Area	Contra Costa	Aug NQC	Wind
PG&E	USWPJR_2_UNITS	39233	GRNRDG	0.69	20.72	1	Bay Area	Contra Costa	Aug NQC	Wind
PG&E	WDMAS_2_UNIT 1	33170	WINDMSTR	9.11	10.07	1	Bay Area	Contra Costa	Aug NQC	Wind
PG&E	ZOND_6_UNIT	35316	ZOND SYS	9.11	4.53	1	Bay Area	Contra Costa	Aug NQC	Wind
PG&E	ZZ_IBMCTL_1_UNIT 1	35637	IBM-CTLE	115	0.00	1	Bay Area	San Jose, South Bay-Moss Landing	No NQC - hist. data	Market
PG&E	ZZ_IMHOFF_1_UNIT 1	33136	CCCSD	12.47	0.00	1	Bay Area	Pittsburg	No NQC - hist. data	QF/Selfgen
PG&E	ZZ_MARKHM_1_CATLST	35863	CATALYST	9.11	0.00	1	Bay Area	San Jose, South Bay-Moss Landing		QF/Selfgen
PG&E	ZZ_NA	36209	SLD ENRG	12.47	0.00	1	Bay Area	South Bay-Moss Landing		QF/Selfgen

Attachment A - List of physical resources by PTO, local area and market ID

PG&E	ZZ_NA	35861	SJ-SCL W	4.3	0.00	1	Bay Area	San Jose, South Bay-Moss Landing	No NQC - hist. data	QF/Selfgen
PG&E	ZZ_SEAWST_6_LAPOS	35312	FOREBAYW	22.01	0.00	1	Bay Area	Contra Costa	No NQC - est. data	Wind
PG&E	ZZ_SHELRF_1_UNITS	33141	SHELL 1	12.47	0.00	1	Bay Area	Pittsburg	No NQC - hist. data	Net Seller
PG&E	ZZ_SHELRF_1_UNITS	33142	SHELL 2	12.47	0.00	1	Bay Area	Pittsburg	No NQC - hist. data	Net Seller
PG&E	ZZ_SHELRF_1_UNITS	33143	SHELL 3	12.47	0.00	1	Bay Area	Pittsburg	No NQC - hist. data	Net Seller
PG&E	ZZ_USWPFK_6_FRICK	35320	FRICKWND	12	1.90	1	Bay Area	Contra Costa	Aug NQC	Wind
PG&E	ZZ_USWPFK_6_FRICK	35320	FRICKWND	12	0.00	2	Bay Area	Contra Costa	Aug NQC	Wind
PG&E	ZZ_ZANKER_1_UNIT 1	35861	SJ-SCL W	4.3	0.00	RN	Bay Area	San Jose, South Bay-Moss Landing	No NQC - hist. data	QF/Selfgen
PG&E	ZZZ_New Unit	35623	SWIFT	21	4.00	BT	Bay Area	San Jose, South Bay-Moss Landing	No NQC - Pmax	Battery
PG&E	ZZZ_New Unit	30522	0354-WD	21	1.83	EW	Bay Area	Contra Costa	No NQC - Pmax	Market
PG&E	ZZZ_New Unit	35302	NUMMI-LV	12.56	0.00	RN	Bay Area		Energy Only	Market
PG&E	ZZZ_New Unit	35859	HGST-LV	12.41	0.00	RN	Bay Area		Energy Only	Market
PG&E	ZZZ_New Unit	35307	A100US-L	12.56	0.00	RN	Bay Area		Energy Only	Market
PG&E	ZZZZ_New Unit	32908	OAK C12	12	2.50	ES	Bay Area	Oakland	OCEI	Battery
PG&E	ZZZZ_New Unit	32788	STTIN L	115	2.50	ES	Bay Area	Oakland	OCEI	Battery
PG&E	ZZZZ_New Unit	32786	OAK C115	115	10.00	ES	Bay Area	Oakland	OCEI	Battery
PG&E	ZZZZ_New Unit	35646	MRGN HIL	115	75.00	ES	Bay Area	Llagas, South Bay-Moss Landing	E-4949	Battery
PG&E	ZZZZ_New Unit	30755	MOSSLNSW	230	182.50	ES	Bay Area	South Bay-Moss Landing	E-4949	Battery
PG&E	ZZZZ_New Unit	30045	MOSSLAND	500	300.00	ES	Bay Area	South Bay-Moss Landing	E-4949	Battery
PG&E	ZZZZZZ_COCOPP_7_UNIT 6	33116	C.COS 6	18	0.00	RT	Bay Area	Contra Costa	Retired	Market
PG&E	ZZZZZZ_COCOPP_7_UNIT 7	33117	C.COS 7	18	0.00	RT	Bay Area	Contra Costa	Retired	Market
PG&E	ZZZZZZ_CONTAN_1_UNIT	36856	CCA100	13.8	0.00	1	Bay Area	San Jose, South Bay-Moss Landing	Retired	MUNI
PG&E	ZZZZZZ_FLOWD1_6_ALTP P1	35318	FLOWDPTR	9.11	0.00	1	Bay Area	Contra Costa	Retired	Wind

Attachment A - List of physical resources by PTO, local area and market ID

PG&E	ZZZZZ_LFC 51_2_UNIT 1	35310	PPASSWND	21	0.00	1	Bay Area		Retired	Wind
PG&E	ZZZZZ_MOSSLD_7_UNIT 6	36405	MOSSLND6	22	0.00	1	Bay Area	South Bay-Moss Landing	Retired	Market
PG&E	ZZZZZ_MOSSLD_7_UNIT 7	36406	MOSSLND7	22	0.00	1	Bay Area	South Bay-Moss Landing	Retired	Market
PG&E	ZZZZZ_PITTSP_7_UNIT 5	33105	PTSB 5	18	0.00	RT	Bay Area	Pittsburg	Retired	Market
PG&E	ZZZZZ_PITTSP_7_UNIT 6	33106	PTSB 6	18	0.00	RT	Bay Area	Pittsburg	Retired	Market
PG&E	ZZZZZ_PITTSP_7_UNIT 7	30000	PTSB 7	20	0.00	RT	Bay Area	Pittsburg	Retired	Market
PG&E	ZZZZZ_UNTDQF_7_UNIT S	33466	UNTED CO	9.11	0.00	1	Bay Area		Retired	QF/Selfgen
PG&E	ADERA_1_SOLAR1	34319	Q644	0.48	0.00	1	Fresno	Herndon	Aug NQC	Solar
PG&E	ADMEST_6_SOLAR	34315	ADAMS_E	12.47	0.00	1	Fresno	Herndon	Energy Only	Solar
PG&E	AGRICO_6_PL3N5	34608	AGRICO	13.8	22.69	3	Fresno	Herndon		Market
PG&E	AGRICO_7_UNIT	34608	AGRICO	13.8	7.47	2	Fresno	Herndon		Market
PG&E	AGRICO_7_UNIT	34608	AGRICO	13.8	43.13	4	Fresno	Herndon		Market
PG&E	AVENAL_6_AVPARK	34265	AVENAL P	12	2.46	1	Fresno	Coalinga	Aug NQC	Solar
PG&E	AVENAL_6_AVSLR1	34691	AVENAL_1	21	0.00	EW	Fresno	Coalinga	Energy Only	Solar
PG&E	AVENAL_6_AVSLR2	34691	AVENAL_1	21	0.00	EW	Fresno	Coalinga	Energy Only	Solar
PG&E	AVENAL_6_SANDDG	34263	SANDDRAG	12	6.54	1	Fresno	Coalinga	Aug NQC	Solar
PG&E	AVENAL_6_SUNCTY	34257	SUNCTY D	12	8.20	1	Fresno	Coalinga	Aug NQC	Solar
PG&E	BALCHS_7_UNIT 1	34624	BALCH	13.2	33.00	1	Fresno	Herndon	Aug NQC	Market
PG&E	BALCHS_7_UNIT 2	34612	BLCH	13.8	52.50	1	Fresno	Herndon	Aug NQC	Market
PG&E	BALCHS_7_UNIT 3	34614	BLCH	13.8	54.60	1	Fresno	Herndon	Aug NQC	Market
PG&E	CANTUA_1_SOLAR	34349	CANTUA_D	12.47	4.10	1	Fresno		Aug NQC	Solar
PG&E	CANTUA_1_SOLAR	34349	CANTUA_D	12.47	4.10	2	Fresno		Aug NQC	Solar
PG&E	CHEVCO_6_UNIT 1	34652	CHV.COAL	9.11	1.94	1	Fresno	Coalinga	Aug NQC	QF/Selfgen
PG&E	CHEVCO_6_UNIT 2	34652	CHV.COAL	9.11	0.92	2	Fresno	Coalinga	Aug NQC	QF/Selfgen
PG&E	CHWCHL_1_BIOMAS	34305	CHWCHLA2	13.8	9.66	1	Fresno	Herndon	Aug NQC	Market
PG&E	CHWCHL_1_UNIT	34301	CHOWCOGN	13.8	48.00	1	Fresno	Herndon		Market
PG&E	COLGA1_6_SHELLW	34654	COLNGAGN	9.11	34.70	1	Fresno	Coalinga	Mothballed	Net Seller
PG&E	CORCAN_1_SOLAR1	34690	CORCORAN	12.47	8.20	FW	Fresno	Herndon, Hanford	Aug NQC	Solar
PG&E	CORCAN_1_SOLAR2	34692	CORCORAN	12.47	4.51	FW	Fresno	Herndon, Hanford	Aug NQC	Solar

Attachment A - List of physical resources by PTO, local area and market ID

PG&E	CRESSY_1_PARKER	34140	CRESSEY	115	0.84		Fresno		Not modeled Aug NQC	MUNI
PG&E	CRNEVL_6_CRNVA	34634	CRANEVLY	12	0.00	1	Fresno	Borden	Aug NQC	Market
PG&E	CRNEVL_6_SJQN 2	34631	SJ2GEN	9.11	0.00	1	Fresno	Borden	Aug NQC	Market
PG&E	CRNEVL_6_SJQN 3	34633	SJ3GEN	9.11	0.00	1	Fresno	Borden	Aug NQC	Market
PG&E	CURTIS_1_CANLCK				0.00		Fresno		Not modeled Aug NQC	Market
PG&E	CURTIS_1_FARFLD				0.29		Fresno		Not modeled Aug NQC	Market
PG&E	DINUBA_6_UNIT	34648	DINUBA E	13.8	2.58	1	Fresno	Herndon, Reedley		Market
PG&E	EEKTMN_6_SOLAR1	34629	KETTLEMN	0.8	0.00	1	Fresno		Energy Only	Solar
PG&E	ELCAP_1_SOLAR				0.62		Fresno		Not Modeled Aug NQC	Solar
PG&E	ELNIDP_6_BIOMAS	34330	ELNIDO	13.8	9.84	1	Fresno		Aug NQC	Market
PG&E	EXCHEC_7_UNIT 1	34306	EXCHQUER	13.8	90.72	1	Fresno		Aug NQC	MUNI
PG&E	EXCLSG_1_SOLAR	34623	Q678	0.5	24.60	1	Fresno		Aug NQC	Solar
PG&E	FRESHW_1_SOLAR1	34699	Q529	0.385	0.00	1	Fresno	Herndon	Energy Only	Solar
PG&E	FRIANT_6_UNITS	34636	FRIANTDM	6.6	10.04	2	Fresno	Borden	Aug NQC	Net Seller
PG&E	FRIANT_6_UNITS	34636	FRIANTDM	6.6	5.36	3	Fresno	Borden	Aug NQC	Net Seller
PG&E	FRIANT_6_UNITS	34636	FRIANTDM	6.6	1.42	4	Fresno	Borden	Aug NQC	Net Seller
PG&E	GIFENS_6_BUGSL1	34644	Q679	0.55	8.20	1	Fresno		Aug NQC	Solar
PG&E	GIFFEN_6_SOLAR	34467	GIFFEN_DIST	12.47	4.10	1	Fresno	Herndon	Aug NQC	Solar
PG&E	GUERNS_6_SOLAR	34463	GUERNSEY_D2	12.47	4.10	5	Fresno		Aug NQC	Solar
PG&E	GUERNS_6_SOLAR	34461	GUERNSEY_D1	12.47	4.10	8	Fresno		Aug NQC	Solar
PG&E	GWFPWR_1_UNITS	34431	GWF_HEP1	13.8	49.23	1	Fresno	Herndon, Hanford		Market
PG&E	GWFPWR_1_UNITS	34433	GWF_HEP2	13.8	49.23	1	Fresno	Herndon, Hanford		Market
PG&E	HAASPH_7_PL1X2	34610	HAAS	13.8	72.00	1	Fresno	Herndon	Aug NQC	Market
PG&E	HAASPH_7_PL1X2	34610	HAAS	13.8	72.00	2	Fresno	Herndon	Aug NQC	Market
PG&E	HELMPG_7_UNIT 1	34600	HELMS	18	407.00	1	Fresno		Aug NQC	Market
PG&E	HELMPG_7_UNIT 2	34602	HELMS	18	407.00	2	Fresno		Aug NQC	Market
PG&E	HELMPG_7_UNIT 3	34604	HELMS	18	404.00	3	Fresno		Aug NQC	Market
PG&E	HENRTA_6_SOLAR1				0.62		Fresno		Not modeled Aug NQC	Solar

Attachment A - List of physical resources by PTO, local area and market ID

PG&E	HENRTA_6_SOLAR2				0.00		Fresno		Not modeled Energy Only	Solar
PG&E	HENRTA_6_UNITA1	34539	GWF_GT1	13.8	49.98	1	Fresno			Market
PG&E	HENRTA_6_UNITA2	34541	GWF_GT2	13.8	49.42	1	Fresno			Market
PG&E	HENRTS_1_SOLAR	34617	Q581	0.38	41.00	1	Fresno		Aug NQC	Solar
PG&E	HURON_6_SOLAR	34557	HURON_DI	12.47	4.10	1	Fresno	Coalinga	Aug NQC	Solar
PG&E	HURON_6_SOLAR	34557	HURON_DI	12.47	4.10	2	Fresno	Coalinga	Aug NQC	Solar
PG&E	JAYNE_6_WLSLR	34639	WESTLNDS	0.48	0.00	1	Fresno	Coalinga	Energy Only	Solar
PG&E	KANSAS_6_SOLAR	34666	KANSASS_S	12.47	0.00	F	Fresno		Energy Only	Solar
PG&E	KERKH1_7_UNIT 1	34344	KERCK1-1	6.6	13.00	1	Fresno	Herndon	Aug NQC	Market
PG&E	KERKH1_7_UNIT 3	34345	KERCK1-3	6.6	12.80	3	Fresno	Herndon	Aug NQC	Market
PG&E	KERKH2_7_UNIT 1	34308	KERCKHOF	13.8	153.90	1	Fresno	Herndon	Aug NQC	Market
PG&E	KERMAN_6_SOLAR1				0.00		Fresno		Not modeled Energy Only	Solar
PG&E	KERMAN_6_SOLAR2				0.00		Fresno		Not modeled Energy Only	Solar
PG&E	KINGCO_1_KINGBR	34642	KINGSBUR	9.11	34.50	1	Fresno	Herndon, Hanford	Aug NQC	Net Seller
PG&E	KINGRV_7_UNIT 1	34616	KINGSRIV	13.8	51.20	1	Fresno	Herndon, Reedley	Aug NQC	Market
PG&E	KNGBRG_1_KBSLR1				0.00		Fresno		Not modeled Energy Only	Solar
PG&E	KNGBRG_1_KBSLR2				0.00		Fresno		Not modeled Energy Only	Solar
PG&E	KNTSTH_6_SOLAR	34694	KENT_S	0.8	0.00	1	Fresno		Energy Only	Solar
PG&E	LEPRFD_1_KANSAS	34680	KANSAS	12.47	8.20	1	Fresno	Hanford	Aug NQC	Solar
PG&E	MALAGA_1_PL1X2	34671	KRCDPCT1	13.8	48.00	1	Fresno	Herndon		Market
PG&E	MALAGA_1_PL1X2	34672	KRCDPCT2	13.8	48.00	1	Fresno	Herndon		Market
PG&E	MCCALL_1_QF	34219	MCCALL 4	12.47	0.48	QF	Fresno	Herndon	Aug NQC	QF/Selfgen
PG&E	MCSWAN_6_UNITS	34320	MCSWAIN	9.11	9.60	1	Fresno		Aug NQC	MUNI
PG&E	MENBIO_6_RENEW1	34339	CALRENEW	12.5	2.05	1	Fresno	Herndon	Aug NQC	Net Seller
PG&E	MENBIO_6_UNIT	34334	BIO PWR	9.11	0.00	1	Fresno		Retired	QF/Selfgen
PG&E	MERCED_1_SOLAR1				0.00		Fresno		Not modeled Energy Only	Solar
PG&E	MERCED_1_SOLAR2				0.00		Fresno		Not modeled Energy Only	Solar
PG&E	MERCFL_6_UNIT	34322	MERCEDFL	9.11	3.36	1	Fresno		Aug NQC	Market
PG&E	MNDOTA_1_SOLAR1	34313	NORTHSTAR	0.2	24.60	1	Fresno		Aug NQC	Solar

Attachment A - List of physical resources by PTO, local area and market ID

PG&E	MNDOTA_1_SOLAR2				0.00		Fresno		Not modeled Energy Only	Solar
PG&E	MSTANG_2_SOLAR	34683	Q643W	0.8	12.30	1	Fresno		Aug NQC	Solar
PG&E	MSTANG_2_SOLAR3	34683	Q643W	0.8	16.40	1	Fresno		Aug NQC	Solar
PG&E	MSTANG_2_SOLAR4	34683	Q643W	0.8	12.30	1	Fresno		Aug NQC	Solar
PG&E	ONLLPP_6_UNITS	34316	ONEILPMP	9.11	18.11	1	Fresno		Aug NQC	MUNI
PG&E	OROLOM_1_SOLAR1	34689	ORO LOMA_3	12.47	0.00	EW	Fresno		Energy Only	Solar
PG&E	OROLOM_1_SOLAR2	34689	ORO LOMA_3	12.47	0.00	EW	Fresno		Energy Only	Solar
PG&E	ORTGA_6_ME1SL1				0.00		Fresno		Not modeled Energy Only	Solar
PG&E	PAIGES_6_SOLAR	34653	Q526	0.55	0.00	1	Fresno	Coalinga	Energy Only	Solar
PG&E	PINFLT_7_UNITS	38720	PINEFLAT	13.8	26.55	1	Fresno	Herndon	Aug NQC	MUNI
PG&E	PINFLT_7_UNITS	38720	PINEFLAT	13.8	26.55	2	Fresno	Herndon	Aug NQC	MUNI
PG&E	PINFLT_7_UNITS	38720	PINEFLAT	13.8	26.55	3	Fresno	Herndon	Aug NQC	MUNI
PG&E	PNCHPP_1_PL1X2	34328	STARGT1	13.8	59.96	1	Fresno			Market
PG&E	PNCHPP_1_PL1X2	34329	STARGT2	13.8	59.96	2	Fresno			Market
PG&E	PNOCHE_1_PL1X2	34142	WHD_PAN2	13.8	49.97	1	Fresno	Herndon		Market
PG&E	PNOCHE_1_UNITA1	34186	DG_PAN1	13.8	48.00	1	Fresno			Market
PG&E	REEDLY_6_SOLAR				0.00		Fresno	Herndon, Reedley	Not modeled Energy Only	Solar
PG&E	S_RITA_6_SOLAR1				0.00		Fresno		Not modeled Energy Only	Solar
PG&E	SCHNDR_1_FIVPTS	34353	SCHINDLER_D	12.47	4.10	1	Fresno	Coalinga	Aug NQC	Solar
PG&E	SCHNDR_1_FIVPTS	34353	SCHINDLER_D	12.47	2.05	2	Fresno	Coalinga	Aug NQC	Solar
PG&E	SCHNDR_1_WSTSDE	34353	SCHINDLER_D	12.47	4.10	3	Fresno	Coalinga	Aug NQC	Solar
PG&E	SCHNDR_1_WSTSDE	34353	SCHINDLER_D	12.47	2.05	4	Fresno	Coalinga	Aug NQC	Solar
PG&E	SGREGY_6_SANGER	34646	SANGERCO	13.8	38.77	1	Fresno		Aug NQC	Market
PG&E	SGREGY_6_SANGER	34646	SANGERCO	13.8	9.31	2	Fresno		Aug NQC	Market
PG&E	STOREY_2_MDRCH2	34253	BORDEN D	12.47	0.34		Fresno		Not modeled Aug NQC	Market
PG&E	STOREY_2_MDRCH3	34253	BORDEN D	12.47	0.23		Fresno		Not modeled Aug NQC	Market
PG&E	STOREY_2_MDRCH4	34253	BORDEN D	12.47	0.42		Fresno		Not modeled Aug NQC	Market

Attachment A - List of physical resources by PTO, local area and market ID

PG&E	STOREY_7_MDRCHW	34209	STOREY D	12.47	0.66	1	Fresno		Aug NQC	Net Seller
PG&E	STROUD_6_SOLAR	34563	STROUD_D	12.47	4.10	1	Fresno	Herndon	Aug NQC	Solar
PG&E	STROUD_6_SOLAR	34563	STROUD_D	12.47	4.10	2	Fresno	Herndon	Aug NQC	Solar
PG&E	TRNQL8_2_AMASR1	365514	Q1032G1	0.55	8.20	1	Fresno		Aug NQC	Solar
PG&E	TRNQL8_2_AZUSR1	365517	Q1032G2	0.55	8.20	2	Fresno		Aug NQC	Solar
PG&E	TRNQL8_2_ROJSR1	365520	Q1032G3	0.55	15.58	3	Fresno		Aug NQC	Solar
PG&E	TRNQL8_2_VERSR1	365520	Q1032G3	0.55	0.00	3	Fresno		Aug NQC	Solar
PG&E	TRNQLT_2_SOLAR	34340	Q643X	0.8	82.00	1	Fresno		Aug NQC	Solar
PG&E	ULTPFR_1_UNIT 1	34640	ULTR.PWR	9.11	24.07	1	Fresno	Herndon	Aug NQC	Market
PG&E	VEGA_6_SOLAR1	34314	VEGA	34.5	0.00	1	Fresno		Energy Only	Solar
PG&E	WAUKNA_1_SOLAR	34696	CORCORANP V_S	21	8.20	1	Fresno	Herndon, Hanford	Aug NQC	Solar
PG&E	WAUKNA_1_SOLAR2	34677	Q558	21	8.10	1	Fresno	Herndon, Hanford	No NQC - Pmax	Solar
PG&E	WFRESN_1_SOLAR				0.00		Fresno		Not modeled Energy Only	Solar
PG&E	WHITNY_6_SOLAR	34673	Q532	0.55	0.00	1	Fresno	Coalinga	Energy Only	Solar
PG&E	WISHON_6_UNITS	34658	WISHON	2.3	4.51	1	Fresno	Borden	Aug NQC	Market
PG&E	WISHON_6_UNITS	34658	WISHON	2.3	4.51	2	Fresno	Borden	Aug NQC	Market
PG&E	WISHON_6_UNITS	34658	WISHON	2.3	4.51	3	Fresno	Borden	Aug NQC	Market
PG&E	WISHON_6_UNITS	34658	WISHON	2.3	4.51	4	Fresno	Borden	Aug NQC	Market
PG&E	WISHON_6_UNITS	34658	WISHON	2.3	0.36	SJ	Fresno	Borden	Aug NQC	Market
PG&E	WOODWR_1_HYDRO				0.00		Fresno		Not modeled Energy Only	Market
PG&E	WRGHTP_7_AMENGY	34207	WRIGHT D	12.47	0.28	QF	Fresno		Aug NQC	QF/Selfgen
PG&E	ZZ_BORDEN_2_QF	34253	BORDEN D	12.47	1.30	QF	Fresno		No NQC - hist. data	Net Seller
PG&E	ZZ_BULLRD_7_SAGNES	34213	BULLD 12	12.47	0.06	1	Fresno		Aug NQC	QF/Selfgen
PG&E	ZZ_JRWOOD_1_UNIT 1	34332	JRWCOGEN	9.11	0.00	1	Fresno			QF/Selfgen
PG&E	ZZ_KERKH1_7_UNIT 2	34343	KERCK1-2	6.6	8.50	2	Fresno	Herndon	No NQC - hist. data	Market
PG&E	ZZ_NA	34485	FRESNOWW	12.5	0.00	1	Fresno		No NQC - hist. data	QF/Selfgen
PG&E	ZZ_NA	34485	FRESNOWW	12.5	0.10	2	Fresno		No NQC - hist. data	QF/Selfgen

Attachment A - List of physical resources by PTO, local area and market ID

PG&E	ZZ_NA	34485	FRESNOWW	12.5	0.00	3	Fresno		No NQC - hist. data	QF/Selfgen
PG&E	ZZ_New Unit	34651	JACALITO-LV	0.55	1.22	RN	Fresno		No NQC - Pmax	Market
PG&E	ZZZ_New Unit	34649	Q965	0.36	5.53	1	Fresno	Herndon	No NQC - est. data	Solar
PG&E	ZZZ_New Unit	365502	Q632BC1	0.55	8.28	1	Fresno		No NQC - est. data	Solar
PG&E	ZZZ_New Unit	34603	JGBSWLT	12.47	0.00	ST	Fresno	Herndon	Energy Only	Market
PG&E	ZZZZ_New Unit	365524	Q1036S	0.36	0.00	1	Fresno		No NQC - est. data	Solar
PG&E	ZZZZ_New Unit	34335	Q723	0.315	20.50	1	Fresno	Borden	No NQC - est. data	Solar
PG&E	ZZZZ_New Unit	365527	Q1036B	0.27	150.00	2	Fresno		No NQC - est. data	Battery
PG&E	ZZZZ_CAPMAD_1_UNIT 1	34179	MADERA_G	13.8	0.00	RT	Fresno		Retired	Market
PG&E	ZZZZ_GATES_6_PL1X2	34553	WHD_GAT2	13.8	0.00	RT	Fresno	Coalinga	Retired	Market
PG&E	ZZZZ_INTTRB_6_UNIT	34342	INT.TURB	9.11	0.00	1	Fresno		Aug NQC	Market
PG&E	BRDGLV_7_BAKER				0.00		Humboldt		Not modeled Aug NQC	Net Seller
PG&E	FAIRHV_6_UNIT	31150	FAIRHAVN	13.8	13.58	1	Humboldt		Aug NQC	Net Seller
PG&E	FTSWRD_6_TRFORK				0.16		Humboldt		Not modeled Aug NQC	Market
PG&E	FTSWRD_7_QFUNTS				0.00		Humboldt		Not modeled Aug NQC	QF/Selfgen
PG&E	GRSCRK_6_BGCKWW				0.00		Humboldt		Not modeled Aug NQC	Market
PG&E	HUMBPP_1_UNITS3	31180	HUMB_G1	13.8	16.32	1	Humboldt			Market
PG&E	HUMBPP_1_UNITS3	31180	HUMB_G1	13.8	15.85	2	Humboldt			Market
PG&E	HUMBPP_1_UNITS3	31180	HUMB_G1	13.8	16.69	3	Humboldt			Market
PG&E	HUMBPP_1_UNITS3	31180	HUMB_G1	13.8	16.22	4	Humboldt			Market
PG&E	HUMBPP_6_UNITS	31181	HUMB_G2	13.8	16.14	5	Humboldt			Market
PG&E	HUMBPP_6_UNITS	31181	HUMB_G2	13.8	16.33	6	Humboldt			Market
PG&E	HUMBPP_6_UNITS	31181	HUMB_G2	13.8	16.24	7	Humboldt			Market
PG&E	HUMBPP_6_UNITS	31182	HUMB_G3	13.8	16.62	8	Humboldt			Market
PG&E	HUMBPP_6_UNITS	31182	HUMB_G3	13.8	16.33	9	Humboldt			Market

Attachment A - List of physical resources by PTO, local area and market ID

PG&E	HUMBPP_6_UNITS	31182	HUMB_G3	13.8	15.95	10	Humboldt			Market
PG&E	HUMBSB_1_QF				0.00		Humboldt		Not modeled Aug NQC	QF/Selfgen
PG&E	KEKAWK_6_UNIT	31166	KEKAWAK	9.1	0.00	1	Humboldt		Aug NQC	Net Seller
PG&E	LAPAC_6_UNIT	31158	LP SAMOA	12.5	0.00	1	Humboldt			Market
PG&E	LOWGAP_1_SUPHR				0.00		Humboldt		Not modeled Aug NQC	Market
PG&E	PACLUM_6_UNIT	31152	PAC.LUMB	13.8	7.88	1	Humboldt		Aug NQC	Net Seller
PG&E	PACLUM_6_UNIT	31152	PAC.LUMB	13.8	7.88	2	Humboldt		Aug NQC	Net Seller
PG&E	PACLUM_6_UNIT	31153	PAC.LUMB	2.4	4.73	3	Humboldt		Aug NQC	Net Seller
PG&E	ZZZZZ_BLULKE_6_BLUEL K	31156	BLUELKPP	12.5	0.00	1	Humboldt		Retired	Market
PG&E	7STDRD_1_SOLAR1	35065	7STNDRD_1	21	8.20	FW	Kern	South Kern PP, Kern Oil	Aug NQC	Solar
PG&E	ADOBEE_1_SOLAR	35021	Q622B	34.5	8.20	1	Kern	South Kern PP	Aug NQC	Solar
PG&E	BDGRCK_1_UNITS	35029	BADGERCK	13.8	42.90	1	Kern	South Kern PP	Aug NQC	Net Seller
PG&E	BEARMT_1_UNIT	35066	PSE-BEAR	13.8	46.60	1	Kern	South Kern PP, Westpark	Aug NQC	Net Seller
PG&E	BKRFLD_2_SOLAR1				0.57		Kern	South Kern PP	Not modeled Aug NQC	Solar
PG&E	DEXZEL_1_UNIT	35024	DEXEL +	13.8	11.98	1	Kern	South Kern PP, Kern Oil	Aug NQC	Net Seller
PG&E	DISCOV_1_CHEVRN	35062	DISCOVERY	13.8	3.53	1	Kern	South Kern PP, Kern Oil	Aug NQC	QF/Selfgen
PG&E	DOUBLC_1_UNITS	35023	DOUBLE C	13.8	52.23	1	Kern	South Kern PP	Aug NQC	Net Seller
PG&E	KERNFT_1_UNITS	35026	KERNFRNT	9.11	52.40	1	Kern	South Kern PP	Aug NQC	Net Seller
PG&E	LAMONT_1_SOLAR1	35019	REGULUS	0.4	24.60	1	Kern	South Kern PP	Aug NQC	Solar
PG&E	LAMONT_1_SOLAR2	35092	Q744G4	0.38	8.20	1	Kern	South Kern PP	Aug NQC	Solar
PG&E	LAMONT_1_SOLAR3	35087	Q744G3	0.4	6.15	3	Kern	South Kern PP	Aug NQC	Solar
PG&E	LAMONT_1_SOLAR4	35059	Q744G2	0.4	17.26	2	Kern	South Kern PP	Aug NQC	Solar
PG&E	LAMONT_1_SOLAR5	35054	Q744G1	0.4	6.83	1	Kern	South Kern PP	Aug NQC	Solar
PG&E	LIVOAK_1_UNIT 1	35058	PSE-LVOK	9.1	44.90	1	Kern	South Kern PP, Kern Oil	Aug NQC	Net Seller
PG&E	MAGUND_1_BKISR1				0.41		Kern	South Kern PP, Kern Oil	Not modeled Aug NQC	Solar
PG&E	MAGUND_1_BKSSR2				2.15		Kern	South Kern PP, Kern Oil	Not modeled Aug NQC	Solar

Attachment A - List of physical resources by PTO, local area and market ID

PG&E	MTNPOS_1_UNIT	35036	MT POSO	13.8	46.64	1	Kern	South Kern PP, Kern Oil	Aug NQC	Net Seller
PG&E	OLDRIV_6_BIOGAS				1.70		Kern	South Kern PP, Kern 70 kV	Not modeled Aug NQC	Market
PG&E	OLDRIV_6_CESDBM				0.94		Kern	South Kern PP, Kern 70 kV	Not modeled Aug NQC	Market
PG&E	OLDRIV_6_LKVBM1				0.94		Kern	South Kern PP, Kern 70 kV	Not modeled Aug NQC	Market
PG&E	OLDRV1_6_SOLAR	35091	OLD_RVR1	12.5	8.20	1	Kern	South Kern PP, Kern 70 kV	Aug NQC	Solar
PG&E	SIERRA_1_UNITS	35027	HISIERRA	9.11	52.43	1	Kern	South Kern PP	Aug NQC	Market
PG&E	SKERN_6_SOLAR1	35089	S_KERN	0.48	8.20	1	Kern	South Kern PP, Kern 70 kV	Aug NQC	Solar
PG&E	SKERN_6_SOLAR2	365563	Q885	0.36	4.10	1	Kern	South Kern PP, Kern 70 kV	Aug NQC	Solar
PG&E	VEDDER_1_SEKERN	35046	SEKR	9.11	4.31	1	Kern	South Kern PP, Kern Oil	Aug NQC	QF/Selfgen
PG&E	ZZZZ_KRNCNY_6_UNIT	35018	KERNCNYN	11	0.00	1	Kern	South Kern PP, Kern 70 kV	Aug NQC	Market
PG&E	ZZZZ_OILDAL_1_UNIT 1	35028	OILDALE	9.11	0.00	RT	Kern	South Kern PP, Kern Oil	Retired	Net Seller
PG&E	ZZZZ_RIOBRV_6_UNIT 1	35020	RIOBRAVO	9.1	0.00	1	Kern	South Kern PP, Kern 70 kV	Aug NQC	Market
PG&E	ZZZZ_ULTOGL_1_POSO	35035	ULTR PWR	9.11	0.00	1	Kern	South Kern PP, Kern Oil	Retired	QF/Selfgen
PG&E	ADLIN_1_UNITS	31435	GEO.ENGY	9.1	8.00	1	NCNB	Eagle Rock, Fulton		Market
PG&E	ADLIN_1_UNITS	31435	GEO.ENGY	9.1	8.00	2	NCNB	Eagle Rock, Fulton		Market
PG&E	CLOVDL_1_SOLAR				0.62		NCNB	Eagle Rock, Fulton	Not modeled Aug NQC	Solar
PG&E	CSTOGA_6_LNDFIL				0.00		NCNB	Fulton	Not modeled Energy Only	Market
PG&E	FULTON_1_QF				0.05		NCNB	Fulton	Not modeled Aug NQC	QF/Selfgen
PG&E	GEYS11_7_UNIT11	31412	GEYSER11	13.8	68.00	1	NCNB	Eagle Rock, Fulton		Market
PG&E	GEYS12_7_UNIT12	31414	GEYSER12	13.8	50.00	1	NCNB	Fulton		Market
PG&E	GEYS13_7_UNIT13	31416	GEYSER13	13.8	56.00	1	NCNB			Market
PG&E	GEYS14_7_UNIT14	31418	GEYSER14	13.8	50.00	1	NCNB	Fulton		Market

Attachment A - List of physical resources by PTO, local area and market ID

PG&E	GEYS16_7_UNIT16	31420	GEYSER16	13.8	49.00	1	NCNB	Fulton		Market
PG&E	GEYS17_7_UNIT17	31422	GEYSER17	13.8	56.00	1	NCNB	Fulton		Market
PG&E	GEYS18_7_UNIT18	31424	GEYSER18	13.8	45.00	1	NCNB			Market
PG&E	GEYS20_7_UNIT20	31426	GEYSER20	13.8	40.00	1	NCNB			Market
PG&E	GYS5X6_7_UNITS	31406	GEYSR5-6	13.8	42.50	1	NCNB	Eagle Rock, Fulton		Market
PG&E	GYS5X6_7_UNITS	31406	GEYSR5-6	13.8	42.50	2	NCNB	Eagle Rock, Fulton		Market
PG&E	GYS7X8_7_UNITS	31408	GEYSER78	13.8	38.00	1	NCNB	Eagle Rock, Fulton		Market
PG&E	GYS7X8_7_UNITS	31408	GEYSER78	13.8	38.00	2	NCNB	Eagle Rock, Fulton		Market
PG&E	GYSRVL_7_WSPRNG				0.87		NCNB	Fulton	Not modeled Aug NQC	QF/Selfgen
PG&E	HILAND_7_YOLOWD				0.00		NCNB	Eagle Rock, Fulton	Not Modeled. Energy Only	Market
PG&E	IGNACO_1_QF				0.13		NCNB		Not modeled Aug NQC	QF/Selfgen
PG&E	INDVLY_1_UNITS	31436	INDIAN V	9.1	0.79	1	NCNB	Eagle Rock, Fulton	Aug NQC	Net Seller
PG&E	MONTPH_7_UNITS	32700	MONTICLO	9.1	3.02	1	NCNB	Fulton	Aug NQC	Market
PG&E	MONTPH_7_UNITS	32700	MONTICLO	9.1	3.02	2	NCNB	Fulton	Aug NQC	Market
PG&E	MONTPH_7_UNITS	32700	MONTICLO	9.1	0.91	3	NCNB	Fulton	Aug NQC	Market
PG&E	NCPA_7_GP1UN1	38106	NCPA1GY1	13.8	31.00	1	NCNB		Aug NQC	MUNI
PG&E	NCPA_7_GP1UN2	38108	NCPA1GY2	13.8	28.00	1	NCNB		Aug NQC	MUNI
PG&E	NCPA_7_GP2UN3	38110	NCPA2GY1	13.8	0.00	1	NCNB	Fulton	Aug NQC	MUNI
PG&E	NCPA_7_GP2UN4	38112	NCPA2GY2	13.8	52.73	1	NCNB	Fulton	Aug NQC	MUNI
PG&E	NOVATO_6_LNDFL				3.67		NCNB		Not modeled Aug NQC	Market
PG&E	POTTER_6_UNITS	31433	POTTRVLY	2.4	1.25	1	NCNB	Eagle Rock, Fulton	Aug NQC	Market
PG&E	POTTER_6_UNITS	31433	POTTRVLY	2.4	0.57	3	NCNB	Eagle Rock, Fulton	Aug NQC	Market
PG&E	POTTER_6_UNITS	31433	POTTRVLY	2.4	0.57	4	NCNB	Eagle Rock, Fulton	Aug NQC	Market
PG&E	POTTER_7_VECINO				0.01		NCNB	Eagle Rock, Fulton	Not modeled Aug NQC	QF/Selfgen
PG&E	SANTFG_7_UNITS	31400	SANTA FE	13.8	31.50	1	NCNB			Market

Attachment A - List of physical resources by PTO, local area and market ID

PG&E	SANTFG_7_UNITS	31400	SANTA FE	13.8	31.50	2	NCNB			Market
PG&E	SMUDGO_7_UNIT 1	31430	SMUDGE01	13.8	47.00	1	NCNB			Market
PG&E	SNMALF_6_UNITS	31446	SONMA LF	9.1	3.56	1	NCNB	Fulton	Aug NQC	QF/Selfgen
PG&E	UKIAH_7_LAKEMN	38020	CITY UKH	115	0.49	1	NCNB	Eagle Rock, Fulton	Aug NQC	MUNI
PG&E	UKIAH_7_LAKEMN	38020	CITY UKH	115	1.21	2	NCNB	Eagle Rock, Fulton	Aug NQC	MUNI
PG&E	ZZZZZ_BEARN_2_UNITS	31402	BEAR CAN	13.8	0.00	1	NCNB	Fulton	Retired	Market
PG&E	ZZZZZ_BEARN_2_UNITS	31402	BEAR CAN	13.8	0.00	2	NCNB	Fulton	Retired	Market
PG&E	ZZZZZ_WDFRDF_2_UNITS	31404	WEST FOR	13.8	0.00	1	NCNB	Fulton		Market
PG&E	ZZZZZ_WDFRDF_2_UNITS	31404	WEST FOR	13.8	0.00	2	NCNB	Fulton		Market
PG&E	ZZZZZ_GEYS17_2_BOTRCK	31421	BOTTLERK	13.8	0.00	1	NCNB	Fulton	Retired	Market
PG&E	ALLGNY_6_HYDRO1				0.03		Sierra		Not modeled Aug NQC	Market
PG&E	APLHIL_1_SLABCK				0.00	1	Sierra	South of Rio Oso, South of Palermo	Not modeled Energy Only	Market
PG&E	BANGOR_6_HYDRO				1.00		Sierra		Not modeled Aug NQC	Market
PG&E	BELDEN_7_UNIT 1	31784	BELDEN	13.8	119.00	1	Sierra	South of Palermo	Aug NQC	Market
PG&E	BIOMAS_1_UNIT 1	32156	WOODLAND	9.11	24.79	1	Sierra	Drum-Rio Oso, South of Palermo	Aug NQC	Net Seller
PG&E	BNNIEN_7_ALTAPH	32376	BONNIE N	60	0.57		Sierra	Placer, Drum-Rio Oso, South of Rio Oso, South of Palermo	Not modeled Aug NQC	Market
PG&E	BOGUE_1_UNITA1	32451	FREC	13.8	47.60	1	Sierra	Bogue, Drum-Rio Oso	Aug NQC	Market
PG&E	BOWMN_6_HYDRO	32480	BOWMAN	9.11	2.57	1	Sierra	Drum-Rio Oso, South of Palermo	Aug NQC	MUNI
PG&E	BUCKCK_2_HYDRO				0.28		Sierra	South of Palermo	Not modeled Aug NQC	Market
PG&E	BUCKCK_7_OAKFLT				1.30		Sierra	South of Palermo	Not modeled Aug NQC	Market
PG&E	BUCKCK_7_PL1X2	31820	BCKS CRK	11	30.63	1	Sierra	South of Palermo	Aug NQC	Market

Attachment A - List of physical resources by PTO, local area and market ID

PG&E	BUCKCK_7_PL1X2	31820	BCKS CRK	11	26.62	2	Sierra	South of Palermo	Aug NQC	Market
PG&E	CAMPFW_7_FARWST	32470	CMP.FARW	9.11	2.90	1	Sierra		Aug NQC	MUNI
PG&E	CHICPK_7_UNIT 1	32462	CHI.PARK	11.5	42.00	1	Sierra	Placer, Drum-Rio Oso, South of Rio Oso, South of Palermo	Aug NQC	MUNI
PG&E	COLGAT_7_UNIT 1	32450	COLGATE1	13.8	161.65	1	Sierra		Aug NQC	MUNI
PG&E	COLGAT_7_UNIT 2	32452	COLGATE2	13.8	161.68	1	Sierra		Aug NQC	MUNI
PG&E	CRESTA_7_PL1X2	31812	CRESTA	11.5	34.86	1	Sierra	South of Palermo	Aug NQC	Market
PG&E	CRESTA_7_PL1X2	31812	CRESTA	11.5	35.54	2	Sierra	South of Palermo	Aug NQC	Market
PG&E	DAVIS_1_SOLAR1				0.41		Sierra	Drum-Rio Oso, South of Palermo	Not modeled Aug NQC	Solar
PG&E	DAVIS_1_SOLAR2				0.41		Sierra	Drum-Rio Oso, South of Palermo	Not modeled Aug NQC	Solar
PG&E	DAVIS_7_MNMETH				1.52		Sierra	Drum-Rio Oso, South of Palermo	Not modeled Aug NQC	Market
PG&E	DEADCK_1_UNIT	31862	DEADWOOD	9.11	0.00	1	Sierra	Drum-Rio Oso	Aug NQC	MUNI
PG&E	DEERCR_6_UNIT 1	32474	DEER CRK	9.11	3.04	1	Sierra	Drum-Rio Oso, South of Palermo	Aug NQC	Market
PG&E	DRUM_7_PL1X2	32504	DRUM 1-2	6.6	13.00	1	Sierra	Drum-Rio Oso, South of Palermo	Aug NQC	Market
PG&E	DRUM_7_PL1X2	32504	DRUM 1-2	6.6	13.00	2	Sierra	Drum-Rio Oso, South of Palermo	Aug NQC	Market
PG&E	DRUM_7_PL3X4	32506	DRUM 3-4	6.6	13.26	1	Sierra	Drum-Rio Oso, South of Palermo	Aug NQC	Market
PG&E	DRUM_7_PL3X4	32506	DRUM 3-4	6.6	15.64	2	Sierra	Drum-Rio Oso, South of Palermo	Aug NQC	Market
PG&E	DRUM_7_UNIT 5	32454	DRUM 5	13.8	50.00	1	Sierra	Drum-Rio Oso, South of Palermo	Aug NQC	Market
PG&E	DUTCH1_7_UNIT 1	32464	DTCHFLT1	11	22.00	1	Sierra	Placer, Drum-Rio Oso, South of Rio Oso, South of Palermo	Aug NQC	Market
PG&E	DUTCH2_7_UNIT 1	32502	DTCHFLT2	6.9	26.00	1	Sierra	Drum-Rio Oso, South of Palermo	Aug NQC	MUNI
PG&E	ELDORO_7_UNIT 1	32513	ELDRADO1	21.6	11.00	1	Sierra	South of Rio Oso, South of Palermo		Market
PG&E	ELDORO_7_UNIT 2	32514	ELDRADO2	21.6	11.00	1	Sierra	South of Rio Oso, South of Palermo		Market

Attachment A - List of physical resources by PTO, local area and market ID

PG&E	FMEADO_6_HELLHL	32486	HELLHOLE	9.11	0.37	1	Sierra	South of Rio Oso, South of Palermo	Aug NQC	MUNI
PG&E	FMEADO_7_UNIT	32508	FRNCH MD	4.2	16.00	1	Sierra	South of Rio Oso, South of Palermo	Aug NQC	MUNI
PG&E	FORBST_7_UNIT 1	31814	FORBSTWN	11.5	37.50	1	Sierra	Drum-Rio Oso	Aug NQC	MUNI
PG&E	GRIDLY_6_SOLAR	38054	GRIDLEY	60	0.00	1	Sierra	Pease	Energy Only	Solar
PG&E	GRNLF1_1_UNITS	32490	GRNLEAF1	13.8	33.36	1	Sierra	Bogue, Drum-Rio Oso	Aug NQC	Market
PG&E	GRNLF1_1_UNITS	32491	GRNLEAF1	13.8	15.84	2	Sierra	Bogue, Drum-Rio Oso	Aug NQC	Market
PG&E	GRNLF2_1_UNIT	32492	GRNLEAF2	13.8	37.77	1	Sierra	Pease, Drum-Rio Oso	Aug NQC	QF/Selfgen
PG&E	HALSEY_6_UNIT	32478	HALSEY F	9.11	13.50	1	Sierra	Placer, Drum-Rio Oso, South of Rio Oso, South of Palermo	Aug NQC	Market
PG&E	HAYPRS_6_QFUNTS	32488	HAYPRES+	9.11	0.04	1	Sierra	Drum-Rio Oso, South of Palermo	Aug NQC	QF/Selfgen
PG&E	HAYPRS_6_QFUNTS	32488	HAYPRES+	9.11	0.05	2	Sierra	Drum-Rio Oso, South of Palermo	Aug NQC	QF/Selfgen
PG&E	HIGGNS_1_COMBIE				0.11		Sierra	Drum-Rio Oso, South of Rio Oso, South of Palermo	Not modeled Aug NQC	Market
PG&E	HIGGNS_7_QFUNTS				0.22		Sierra	Drum-Rio Oso, South of Rio Oso, South of Palermo	Not modeled Aug NQC	QF/Selfgen
PG&E	KANAKA_1_UNIT				0.00		Sierra	Drum-Rio Oso	Not modeled Aug NQC	MUNI
PG&E	KELYRG_6_UNIT	31834	KELLYRDG	9.11	11.00	1	Sierra	Drum-Rio Oso	Aug NQC	MUNI
PG&E	LIVEOK_6_SOLAR				0.51		Sierra	Pease	Not modeled Aug NQC	Solar
PG&E	LODIEC_2_PL1X2	38124	LODI ST1	18	103.55	1	Sierra	South of Rio Oso, South of Palermo		MUNI
PG&E	LODIEC_2_PL1X2	38123	LODI CT1	18	199.03	1	Sierra	South of Rio Oso, South of Palermo		MUNI
PG&E	MDFKRL_2_PROJCT	32456	MIDLFORK	13.8	63.94	1	Sierra	South of Rio Oso, South of Palermo	Aug NQC	MUNI
PG&E	MDFKRL_2_PROJCT	32458	RALSTON	13.8	82.13	1	Sierra	South of Rio Oso, South of Palermo	Aug NQC	MUNI

Attachment A - List of physical resources by PTO, local area and market ID

PG&E	MDFKRL_2_PROJCT	32456	MIDLFORK	13.8	63.94	2	Sierra	South of Rio Oso, South of Palermo	Aug NQC	MUNI
PG&E	NAROW1_2_UNIT	32466	NARROWS1	9.1	12.00	1	Sierra		Aug NQC	Market
PG&E	NAROW2_2_UNIT	32468	NARROWS2	9.1	28.51	1	Sierra		Aug NQC	MUNI
PG&E	NWCSTL_7_UNIT 1	32460	NEWCASTLE	13.2	0.06	1	Sierra	Placer, Drum-Rio Oso, South of Rio Oso, South of Palermo	Aug NQC	Market
PG&E	OROVIL_6_UNIT	31888	OROVILLE	9.11	7.50	1	Sierra	Drum-Rio Oso	Aug NQC	Market
PG&E	OXBOW_6_DRUM	32484	OXBOW F	9.11	3.37	1	Sierra	Drum-Rio Oso, South of Palermo	Aug NQC	MUNI
PG&E	PLACVL_1_CHILIB	32510	CHILIBAR	4.2	8.40	1	Sierra	South of Rio Oso, South of Palermo	Aug NQC	Market
PG&E	PLACVL_1_RCKCRE				2.39		Sierra	South of Rio Oso, South of Palermo	Not modeled Aug NQC	Market
PG&E	PLSNTG_7_LNCLND	32408	PLSNT GR	60	3.06		Sierra	Drum-Rio Oso, South of Rio Oso, South of Palermo	Not modeled Aug NQC	Market
PG&E	POEPH_7_UNIT 1	31790	POE 1	13.8	60.00	1	Sierra	South of Palermo	Aug NQC	Market
PG&E	POEPH_7_UNIT 2	31792	POE 2	13.8	60.00	1	Sierra	South of Palermo	Aug NQC	Market
PG&E	RCKCRK_7_UNIT 1	31786	ROCK CK1	13.8	57.00	1	Sierra	South of Palermo	Aug NQC	Market
PG&E	RCKCRK_7_UNIT 2	31788	ROCK CK2	13.8	56.90	1	Sierra	South of Palermo	Aug NQC	Market
PG&E	RIOOSO_1_QF				0.94		Sierra	Drum-Rio Oso, South of Palermo	Not modeled Aug NQC	QF/Selfgen
PG&E	ROLLIN_6_UNIT	32476	ROLLINSF	9.11	13.50	1	Sierra	Drum-Rio Oso, South of Palermo	Aug NQC	MUNI
PG&E	SLYCRK_1_UNIT 1	31832	SLY.CR.	9.11	13.00	1	Sierra	Drum-Rio Oso	Aug NQC	Market
PG&E	SPAULD_6_UNIT 3	32472	SPAULDG	9.11	3.27	3	Sierra	Drum-Rio Oso, South of Palermo	Aug NQC	Market
PG&E	SPAULD_6_UNIT12	32472	SPAULDG	9.11	7.00	1	Sierra	Drum-Rio Oso, South of Palermo	Aug NQC	Market
PG&E	SPAULD_6_UNIT12	32472	SPAULDG	9.11	4.40	2	Sierra	Drum-Rio Oso, South of Palermo	Aug NQC	Market
PG&E	SPI LI_2_UNIT 1	32498	SPILINCF	12.5	10.19	1	Sierra	Drum-Rio Oso, South of Rio Oso, South of Palermo	Aug NQC	Net Seller
PG&E	STIGCT_2_LODI	38114	Stig CC	13.8	49.50	1	Sierra	South of Rio Oso, South of Palermo		MUNI

Attachment A - List of physical resources by PTO, local area and market ID

PG&E	ULTRCK_2_UNIT	32500	ULTR RCK	9.11	22.83	1	Sierra	Drum-Rio Oso, South of Rio Oso, South of Palermo	Aug NQC	Market
PG&E	WDLEAF_7_UNIT 1	31794	WOODLEAF	13.8	60.00	1	Sierra	Drum-Rio Oso	Aug NQC	MUNI
PG&E	WHEATL_6_LNDFIL	32350	WHEATLND	60	3.55		Sierra		Not modeled Aug NQC	Market
PG&E	WISE_1_UNIT 1	32512	WISE	12	14.50	1	Sierra	Placer, Drum-Rio Oso, South of Rio Oso, South of Palermo	Aug NQC	Market
PG&E	WISE_1_UNIT 2	32512	WISE	12	3.20	1	Sierra	Placer, Drum-Rio Oso, South of Rio Oso, South of Palermo	Aug NQC	Market
PG&E	YUBACT_1_SUNSWT	32494	YUBA CTY	9.11	49.97	1	Sierra	Pease, Drum-Rio Oso	Aug NQC	Net Seller
PG&E	YUBACT_6_UNITA1	32496	YCEC	13.8	47.60	1	Sierra	Pease, Drum-Rio Oso		Market
PG&E	ZZ_NA	32162	RIV.DLTA	9.11	0.00	1	Sierra	Drum-Rio Oso, South of Palermo	No NQC - hist. data	QF/Selfgen
PG&E	ZZ_UCDAVS_1_UNIT	32166	UC DAVIS	9.11	0.00	RN	Sierra	Drum-Rio Oso, South of Palermo	No NQC - hist. data	QF/Selfgen
PG&E	ZZZ_New Unit	365510	Q653F	0.48	4.92	1	Sierra	Drum-Rio Oso, South of Palermo	No NQC - est. data	Solar
PG&E	ZZZZ_GOLDHL_1_QF				0.00		Sierra	South of Rio Oso, South of Palermo	Not modeled	QF/Selfgen
PG&E	ZZZZ_PACORO_6_UNIT	31890	PO POWER	9.11	0.00	1	Sierra	Drum-Rio Oso	Retired	QF/Selfgen
PG&E	ZZZZ_PACORO_6_UNIT	31890	PO POWER	9.11	0.00	2	Sierra	Drum-Rio Oso	Retired	QF/Selfgen
PG&E	BEARDS_7_UNIT 1	34074	BEARDSLY	6.9	8.36	1	Stockton	Tesla-Bellota, Stanislaus	Aug NQC	MUNI
PG&E	CAMCHE_1_PL1X3	33850	CAMANCHE	4.2	0.79	1	Stockton	Tesla-Bellota	Aug NQC	MUNI
PG&E	CAMCHE_1_PL1X3	33850	CAMANCHE	4.2	0.79	2	Stockton	Tesla-Bellota	Aug NQC	MUNI
PG&E	CAMCHE_1_PL1X3	33850	CAMANCHE	4.2	0.79	3	Stockton	Tesla-Bellota	Aug NQC	MUNI
PG&E	COGNAT_1_UNIT	33818	STCKNBIOMASS	13.8	44.35	1	Stockton	Weber	Aug NQC	Net Seller
PG&E	CRWCK_1_SOLAR1	34051	Q539	34.5	0.00	1	Stockton	Tesla-Bellota	Energy Only	Solar

Attachment A - List of physical resources by PTO, local area and market ID

PG&E	DONNLS_7_UNIT	34058	DONNELLS	13.8	72.00	1	Stockton	Tesla-Bellota, Stanislaus	Aug NQC	MUNI
PG&E	FROGTN_1_UTICAA				1.40		Stockton	Tesla-Bellota, Stanislaus	Not Modeled Aug NQC	Market
PG&E	LOCKFD_1_BEARCK				0.62		Stockton	Tesla-Bellota	Not Modeled Aug NQC	Market
PG&E	LOCKFD_1_KSOLAR				0.41		Stockton	Tesla-Bellota	Not Modeled Aug NQC	Solar
PG&E	LODI25_2_UNIT 1	38120	LODI25CT	9.11	23.80	1	Stockton	Lockeford		MUNI
PG&E	MANTEC_1_ML1SR1				0.00		Stockton	Tesla-Bellota	Not modeled Energy Only	Solar
PG&E	PEORIA_1_SOLAR				0.62		Stockton	Tesla-Bellota, Stanislaus	Not modeled Aug NQC	Solar
PG&E	PHOENX_1_UNIT				0.82		Stockton	Tesla-Bellota, Stanislaus	Not modeled Aug NQC	Market
PG&E	SCHLTE_1_PL1X3	33805	GWFTRCY1	13.8	91.07	1	Stockton	Tesla-Bellota		Market
PG&E	SCHLTE_1_PL1X3	33807	GWFTRCY2	13.8	91.07	1	Stockton	Tesla-Bellota		Market
PG&E	SCHLTE_1_PL1X3	33811	GWFTRCY3	13.8	146.76	1	Stockton	Tesla-Bellota		Market
PG&E	SMPRIP_1_SMPSON	33810	SP CMPNY	13.8	46.05	1	Stockton	Tesla-Bellota	Aug NQC	Market
PG&E	SNDBAR_7_UNIT 1	34060	SANDBAR	13.8	12.93	1	Stockton	Tesla-Bellota, Stanislaus	Aug NQC	MUNI
PG&E	SPIFBD_1_PL1X2	34055	SPISONORA	13.8	7.05	1	Stockton	Tesla-Bellota, Stanislaus	Aug NQC	Market
PG&E	SPRGAP_1_UNIT 1	34078	SPRNG GP	6	0.00	1	Stockton	Tesla-Bellota, Stanislaus	Aug NQC	Market
PG&E	STANIS_7_UNIT 1	34062	STANISLS	13.8	91.00	1	Stockton	Tesla-Bellota, Stanislaus	Aug NQC	Market
PG&E	STNRES_1_UNIT	34056	STNSLSRP	13.8	19.04	1	Stockton	Tesla-Bellota	Aug NQC	Net Seller
PG&E	THMENG_1_UNIT 1	33806	TH.E.DV.	13.8	0.00	1	Stockton	Tesla-Bellota	Aug NQC	Net Seller
PG&E	TULLCK_7_UNITS	34076	TULLOCH	6.9	5.95	1	Stockton	Tesla-Bellota	Aug NQC	MUNI
PG&E	TULLCK_7_UNITS	34076	TULLOCH	6.9	6.70	2	Stockton	Tesla-Bellota	Aug NQC	MUNI
PG&E	TULLCK_7_UNITS	34076	TULLOCH	6.9	4.40	3	Stockton	Tesla-Bellota	Aug NQC	MUNI
PG&E	ULTPCH_1_UNIT 1	34050	CH.STN.	13.8	16.19	1	Stockton	Tesla-Bellota, Stanislaus	Aug NQC	QF/Selfgen
PG&E	VLYHOM_7_SSJID				0.57		Stockton	Tesla-Bellota, Stanislaus	Not modeled Aug NQC	MUNI

Attachment A - List of physical resources by PTO, local area and market ID

PG&E	WEBER_6_FORWRD				4.20		Stockton	Weber	Not modeled Aug NQC	Market
PG&E	ZZ_NA	33687	STKTN WW	60	1.50	1	Stockton	Weber	No NQC - hist. data	QF/Selfgen
PG&E	ZZ_NA	33821	PAC_ETH	12.5	0.00	RN	Stockton	Weber	No NQC - hist. data	QF/Selfgen
PG&E	ZZZZZ_FROGTN_7_UTICA				0.00		Stockton	Tesla-Bellota, Stanislaus	Not modeled Energy Only	Market
PG&E	ZZZZZ_STOKCG_1_UNIT 1	33814	INGREDION	12.5	0.00	RN	Stockton	Tesla-Bellota	Retired	QF/Selfgen
PG&E	ZZZZZZ_NA	33830	GEN.MILL	9.11	0.00	1	Stockton	Lockeford	Retired	QF/Selfgen
PG&E	ZZZZZZ_SANJOA_1_UNI T 1	33808	SJ COGEN	13.8	0.00	1	Stockton	Tesla-Bellota	Retired	QF/Selfgen
SCE	ACACIA_6_SOLAR	29878	ACACIA_G	0.48	8.20	EQ	BC/Ventura		Energy Only	Solar
SCE	ALAMO_6_UNIT	25653	ALAMO SC	13.8	15.07	1	BC/Ventura		Aug NQC	MUNI
SCE	BGSKYN_2_AS2SR1	29773	ANTLOP2_G1	0.42	43.05	EQ	BC/Ventura		Aug NQC	Solar
SCE	BIGCRK_2_EXESWD	24323	PORTAL	4.8	9.45	1	BC/Ventura	Rector, Vestal	Aug NQC	Market
SCE	BIGCRK_2_EXESWD	24306	B CRK1-1	7.2	19.58	1	BC/Ventura	Rector, Vestal	Aug NQC	Market
SCE	BIGCRK_2_EXESWD	24311	B CRK3-1	13.8	34.44	1	BC/Ventura	Rector, Vestal	Aug NQC	Market
SCE	BIGCRK_2_EXESWD	24308	B CRK2-1	13.8	49.99	1	BC/Ventura	Rector, Vestal	Aug NQC	Market
SCE	BIGCRK_2_EXESWD	24317	MAMOTH1G	13.8	92.02	1	BC/Ventura	Rector, Vestal	Aug NQC	Market
SCE	BIGCRK_2_EXESWD	24306	B CRK1-1	7.2	21.26	2	BC/Ventura	Rector, Vestal	Aug NQC	Market
SCE	BIGCRK_2_EXESWD	24311	B CRK3-1	13.8	33.46	2	BC/Ventura	Rector, Vestal	Aug NQC	Market
SCE	BIGCRK_2_EXESWD	24308	B CRK2-1	13.8	51.18	2	BC/Ventura	Rector, Vestal	Aug NQC	Market
SCE	BIGCRK_2_EXESWD	24318	MAMOTH2G	13.8	92.02	2	BC/Ventura	Rector, Vestal	Aug NQC	Market
SCE	BIGCRK_2_EXESWD	24309	B CRK2-2	7.2	18.40	3	BC/Ventura	Rector, Vestal	Aug NQC	Market
SCE	BIGCRK_2_EXESWD	24307	B CRK1-2	13.8	21.26	3	BC/Ventura	Rector, Vestal	Aug NQC	Market
SCE	BIGCRK_2_EXESWD	24312	B CRK3-2	13.8	34.44	3	BC/Ventura	Rector, Vestal	Aug NQC	Market
SCE	BIGCRK_2_EXESWD	24309	B CRK2-2	7.2	19.39	4	BC/Ventura	Rector, Vestal	Aug NQC	Market
SCE	BIGCRK_2_EXESWD	24307	B CRK1-2	13.8	30.71	4	BC/Ventura	Rector, Vestal	Aug NQC	Market
SCE	BIGCRK_2_EXESWD	24312	B CRK3-2	13.8	35.43	4	BC/Ventura	Rector, Vestal	Aug NQC	Market
SCE	BIGCRK_2_EXESWD	24310	B CRK2-3	7.2	16.73	5	BC/Ventura	Rector, Vestal	Aug NQC	Market
SCE	BIGCRK_2_EXESWD	24313	B CRK3-3	13.8	35.92	5	BC/Ventura	Rector, Vestal	Aug NQC	Market
SCE	BIGCRK_2_EXESWD	24310	B CRK2-3	7.2	18.21	6	BC/Ventura	Rector, Vestal	Aug NQC	Market
SCE	BIGCRK_2_EXESWD	24314	B CRK 4	11.5	49.60	41	BC/Ventura	Rector, Vestal	Aug NQC	Market
SCE	BIGCRK_2_EXESWD	24314	B CRK 4	11.5	49.80	42	BC/Ventura	Rector, Vestal	Aug NQC	Market

Attachment A - List of physical resources by PTO, local area and market ID

SCE	BIGCRK_2_EXESWD	24315	B CRK 8	13.8	24.01	81	BC/Ventura	Rector, Vestal	Aug NQC	Market
SCE	BIGCRK_2_EXESWD	24315	B CRK 8	13.8	43.30	82	BC/Ventura	Rector, Vestal	Aug NQC	Market
SCE	BIGCRK_7_DAM7				0.00		BC/Ventura	Rector, Vestal	Not modeled Energy Only	Market
SCE	BIGCRK_7_MAMRES				0.00		BC/Ventura	Rector, Vestal	Not modeled Energy Only	Market
SCE	BIGSKY_2_BSKSR6	29742	BSKY G BC	0.42	8.20	1	BC/Ventura		Aug NQC	Solar
SCE	BIGSKY_2_BSKSR7	29703	BSKY G WABS	0.42	8.20	1	BC/Ventura		Aug NQC	Solar
SCE	BIGSKY_2_BSKSR8	29724	BSKY G ABSR	0.38	8.20	1	BC/Ventura		Aug NQC	Solar
SCE	BIGSKY_2_SOLAR1	29727	BSKY G SMR	0.42	8.20	1	BC/Ventura		Aug NQC	Solar
SCE	BIGSKY_2_SOLAR2	29701	BSKY_G_ESC	0.42	34.41	1	BC/Ventura		Aug NQC	Solar
SCE	BIGSKY_2_SOLAR3	29745	BSKY_G_BD	0.42	8.20	1	BC/Ventura		Aug NQC	Solar
SCE	BIGSKY_2_SOLAR4	29736	BSKY_G_BA	0.42	20.00	1	BC/Ventura		Aug NQC	Solar
SCE	BIGSKY_2_SOLAR5	29739	BSKY_G_BB	0.42	2.05	1	BC/Ventura		Aug NQC	Solar
SCE	BIGSKY_2_SOLAR6	29730	BSKY_G_SOL V	0.42	34.85	1	BC/Ventura		Aug NQC	Solar
SCE	BIGSKY_2_SOLAR7	29733	BSKY_G_ADS R	0.42	20.50	1	BC/Ventura		Aug NQC	Solar
SCE	CEDUCR_2_SOLAR1	25049	DUCOR1	0.385	0.00	EQ	BC/Ventura	Vestal	Energy Only	Solar
SCE	CEDUCR_2_SOLAR2	25052	DUCOR2	0.385	0.00	EQ	BC/Ventura	Vestal	Energy Only	Solar
SCE	CEDUCR_2_SOLAR3	25055	DUCOR3	0.385	0.00	EQ	BC/Ventura	Vestal	Energy Only	Solar
SCE	CEDUCR_2_SOLAR4	25058	DUCOR4	0.385	0.00	EQ	BC/Ventura	Vestal	Energy Only	Solar
SCE	DELSUR_6_BSOLAR				1.23		BC/Ventura		Not modeled Aug NQC	Solar
SCE	DELSUR_6_CREST	24411	DELSUR_DIST	66	0.00	A2	BC/Ventura		Energy Only	Market
SCE	DELSUR_6_DRYFRB	24411	DELSUR_DIST	66	2.05	A2	BC/Ventura		Aug NQC	Market
SCE	DELSUR_6_SOLAR1	24411	DELSUR_DIST	66	2.67	AS	BC/Ventura		Aug NQC	Solar
SCE	EASTWD_7_UNIT	24319	EASTWOOD	13.8	199.00	1	BC/Ventura	Rector, Vestal		Market
SCE	EDMONS_2_NSPIN	25605	EDMON1AP	14.4	16.86	1	BC/Ventura		Pumps	MUNI
SCE	EDMONS_2_NSPIN	25606	EDMON2AP	14.4	16.86	2	BC/Ventura		Pumps	MUNI
SCE	EDMONS_2_NSPIN	25607	EDMON3AP	14.4	16.86	3	BC/Ventura		Pumps	MUNI
SCE	EDMONS_2_NSPIN	25607	EDMON3AP	14.4	16.86	4	BC/Ventura		Pumps	MUNI
SCE	EDMONS_2_NSPIN	25608	EDMON4AP	14.4	16.86	5	BC/Ventura		Pumps	MUNI

Attachment A - List of physical resources by PTO, local area and market ID

SCE	EDMONS_2_NSPIN	25608	EDMON4AP	14.4	16.86	6	BC/Ventura		Pumps	MUNI
SCE	EDMONS_2_NSPIN	25609	EDMON5AP	14.4	16.86	7	BC/Ventura		Pumps	MUNI
SCE	EDMONS_2_NSPIN	25609	EDMON5AP	14.4	16.86	8	BC/Ventura		Pumps	MUNI
SCE	EDMONS_2_NSPIN	25610	EDMON6AP	14.4	16.86	9	BC/Ventura		Pumps	MUNI
SCE	EDMONS_2_NSPIN	25610	EDMON6AP	14.4	16.86	10	BC/Ventura		Pumps	MUNI
SCE	EDMONS_2_NSPIN	25611	EDMON7AP	14.4	16.85	11	BC/Ventura		Pumps	MUNI
SCE	EDMONS_2_NSPIN	25611	EDMON7AP	14.4	16.85	12	BC/Ventura		Pumps	MUNI
SCE	EDMONS_2_NSPIN	25612	EDMON8AP	14.4	16.85	13	BC/Ventura		Pumps	MUNI
SCE	EDMONS_2_NSPIN	25612	EDMON8AP	14.4	16.85	14	BC/Ventura		Pumps	MUNI
SCE	GLDFGR_6_SOLAR1	25079	PRIDE B G	0.64	8.20	1	BC/Ventura		Aug NQC	Solar
SCE	GLDFGR_6_SOLAR2	25169	PRIDE C G	0.64	4.67	1	BC/Ventura		Aug NQC	Solar
SCE	GLOW_6_SOLAR	29896	APPINV	0.42	0.00	EQ	BC/Ventura		Energy Only	Solar
SCE	GOLETA_2_QF	25335	GOLETA_DIST	66	0.05	S1	BC/Ventura	S.Clara, Moorpark, Goleta	Aug NQC	QF/Selfgen
SCE	GOLETA_6_ELLWOD	29004	ELLWOOD	13.8	0.00	1	BC/Ventura	S.Clara, Moorpark, Goleta	Retirement requested effective date January 1, 2019	Market
SCE	GOLETA_6_EXGEN	24362	EXGEN2	13.8	0.00	G1	BC/Ventura	S.Clara, Moorpark, Goleta	Aug NQC - Currently out of service	QF/Selfgen
SCE	GOLETA_6_EXGEN	24326	EXGEN1	13.8	0.00	S1	BC/Ventura	S.Clara, Moorpark, Goleta	Aug NQC - Currently out of service	QF/Selfgen
SCE	GOLETA_6_GAVOTA	25335	GOLETA_DIST	66	0.01	S1	BC/Ventura	S.Clara, Moorpark, Goleta	Aug NQC	Market
SCE	GOLETA_6_TAJIGS	25335	GOLETA_DIST	66	2.84	S1	BC/Ventura	S.Clara, Moorpark, Goleta	Aug NQC	Market
SCE	LEBECS_2_UNITS	29051	PSTRIAG1	18	165.58	G1	BC/Ventura		Aug NQC	Market
SCE	LEBECS_2_UNITS	29052	PSTRIAG2	18	165.58	G2	BC/Ventura		Aug NQC	Market
SCE	LEBECS_2_UNITS	29054	PSTRIAG3	18	165.58	G3	BC/Ventura		Aug NQC	Market
SCE	LEBECS_2_UNITS	29053	PSTRIAS1	18	170.45	S1	BC/Ventura		Aug NQC	Market
SCE	LEBECS_2_UNITS	29055	PSTRIAS2	18	82.79	S2	BC/Ventura		Aug NQC	Market
SCE	LITLRK_6_GBCSR1	24419	LTLRCK_DIST	66	1.23	AS	BC/Ventura		Aug NQC	Solar
SCE	LITLRK_6_SEPV01	24419	LTLRCK_DIST	66	0.00	AS	BC/Ventura		Energy Only	Market

Attachment A - List of physical resources by PTO, local area and market ID

SCE	LITLRK_6_SOLAR1	24419	LTLRCK_DIST	66	2.05	AS	BC/Ventura		Aug NQC	Solar
SCE	LITLRK_6_SOLAR2	24419	LTLRCK_DIST	66	0.82	AS	BC/Ventura		Aug NQC	Solar
SCE	LITLRK_6_SOLAR3	24419	LTLRCK_DIST	66	0.82	AS	BC/Ventura		Aug NQC	Solar
SCE	LITLRK_6_SOLAR4	24419	LTLRCK_DIST	66	1.23	AS	BC/Ventura		Aug NQC	Solar
SCE	LNCSTR_6_CREST				0.00		BC/Ventura		Not modeled Energy Only	Market
SCE	MNDALY_6_MCGRTH	29306	MCGPKGEN	13.8	47.20	1	BC/Ventura	S.Clara, Moorpark		Market
SCE	MOORPK_2_CALABS	25081	WDT251	13.8	5.03	EQ	BC/Ventura	Moorpark	Aug NQC	Market
SCE	MOORPK_6_QF				0.80		BC/Ventura	Moorpark	Not modeled Aug NQC	Market
SCE	NEENCH_6_SOLAR	29900	ALPINE_G	0.48	27.06	EQ	BC/Ventura		Aug NQC	Solar
SCE	OASIS_6_CREST	24421	OASIS_DIST	66	0.00	AS	BC/Ventura		Energy Only	Market
SCE	OASIS_6_GBDSR4				1.23		BC/Ventura		Not modeled Aug NQC	Solar
SCE	OASIS_6_SOLAR1	25095	SOLARISG2	0.2	0.00	EQ	BC/Ventura		Not modeled Energy Only	Solar
SCE	OASIS_6_SOLAR2	25075	SOLARISG	0.2	8.20	EQ	BC/Ventura		Aug NQC	Solar
SCE	OASIS_6_SOLAR3				0.00		BC/Ventura		Not modeled Energy Only	Solar
SCE	OMAR_2_UNIT 1	24102	OMAR 1G	13.8	74.40	1	BC/Ventura			Net Seller
SCE	OMAR_2_UNIT 2	24103	OMAR 2G	13.8	75.80	2	BC/Ventura			Net Seller
SCE	OMAR_2_UNIT 3	24104	OMAR 3G	13.8	78.60	3	BC/Ventura			Net Seller
SCE	OMAR_2_UNIT 4	24105	OMAR 4G	13.8	81.44	4	BC/Ventura			Net Seller
SCE	ORMOND_7_UNIT 1	24107	ORMOND1G	26	0.00	1	BC/Ventura	Moorpark	Retirement requested effective date October 1, 2018	Market
SCE	ORMOND_7_UNIT 2	24108	ORMOND2G	26	0.00	2	BC/Ventura	Moorpark	Retirement requested effective date October 1, 2018	Market
SCE	OSO_6_NSPIN	25614	OSO A P	13.2	2.25	1	BC/Ventura		Pumps	MUNI
SCE	OSO_6_NSPIN	25614	OSO A P	13.2	2.25	2	BC/Ventura		Pumps	MUNI
SCE	OSO_6_NSPIN	25614	OSO A P	13.2	2.25	3	BC/Ventura		Pumps	MUNI
SCE	OSO_6_NSPIN	25614	OSO A P	13.2	2.25	4	BC/Ventura		Pumps	MUNI

Attachment A - List of physical resources by PTO, local area and market ID

SCE	OSO_6_NSPIN	25615	OSO B P	13.2	2.25	5	BC/Ventura		Pumps	MUNI
SCE	OSO_6_NSPIN	25615	OSO B P	13.2	2.25	6	BC/Ventura		Pumps	MUNI
SCE	OSO_6_NSPIN	25615	OSO B P	13.2	2.25	7	BC/Ventura		Pumps	MUNI
SCE	OSO_6_NSPIN	25615	OSO B P	13.2	2.25	8	BC/Ventura		Pumps	MUNI
SCE	PANDOL_6_UNIT	24113	PANDOL	13.8	0.00	1	BC/Ventura	Vestal	Retired	Market
SCE	PANDOL_6_UNIT	24113	PANDOL	13.8	0.00	2	BC/Ventura	Vestal	Retired	Market
SCE	PLAINV_6_BSOLAR	29917	SSOLAR)GR WKS	0.8	0.00	1	BC/Ventura		Energy Only	Solar
SCE	PLAINV_6_DSOLAR	29914	WADR_PV	0.42	4.10	1	BC/Ventura		Aug NQC	Solar
SCE	PLAINV_6_NLRSR1	29921	NLR_INVTR	0.42	0.00	1	BC/Ventura		Aug NQC	Solar
SCE	PLAINV_6_SOLAR3	25089	CNTRL ANT G	0.42	0.00	1	BC/Ventura		Energy Only	Solar
SCE	PLAINV_6_SOLARC	25086	SIRA SOLAR G	0.8	0.00	1	BC/Ventura		Energy Only	Solar
SCE	PMDLET_6_SOLAR1				4.10		BC/Ventura		Not modeled Aug NQC	Solar
SCE	RECTOR_2_CREST	25333	RECTOR_DIS T	66	0.00	S1	BC/Ventura	Rector, Vestal	Aug NQC	Market
SCE	RECTOR_2_KAWEAH	24370	KAWGEN	13.8	1.77	1	BC/Ventura	Rector, Vestal	Aug NQC	Market
SCE	RECTOR_2_KAWH 1	24370	KAWGEN	13.8	0.65	1	BC/Ventura	Rector, Vestal	Aug NQC	Market
SCE	RECTOR_2_QF	25333	RECTOR_DIS T	66	0.07	S1	BC/Ventura	Rector, Vestal	Aug NQC	QF/Selfgen
SCE	RECTOR_7_TULARE	25333	RECTOR_DIS T	66	0.00	S1	BC/Ventura	Rector, Vestal	Aug NQC	Market
SCE	REDMAN_2_SOLAR	24425	REDMAN_DIS T	66	1.54	AS	BC/Ventura		Aug NQC	Solar
SCE	ROSMND_6_SOLAR	24434	ROSAMOND_ DIS	66	1.23	AS	BC/Ventura		Aug NQC	Solar
SCE	RSMSLR_6_SOLAR1	29984	DAWNGEN	0.8	8.20	EQ	BC/Ventura		Aug NQC	Solar
SCE	RSMSLR_6_SOLAR2	29888	TWILGHTG	0.8	8.20	EQ	BC/Ventura		Aug NQC	Solar
SCE	SAUGUS_2_TOLAND	24135	SAUGUS	66	0.00		BC/Ventura		Not modeled Energy Only	Market
SCE	SAUGUS_6_MWDFTH	25336	SAUGUS_MW D	66	8.76	S1	BC/Ventura		Aug NQC	MUNI
SCE	SAUGUS_6_PTCHGN	24118	PITCHGEN	13.8	20.64	D1	BC/Ventura		Aug NQC	MUNI
SCE	SAUGUS_6_QF	24135	SAUGUS	66	0.62		BC/Ventura		Not modeled Aug NQC	QF/Selfgen
SCE	SAUGUS_7_CHIQCN	24135	SAUGUS	66	5.71		BC/Ventura		Not modeled Aug NQC	Market

Attachment A - List of physical resources by PTO, local area and market ID

SCE	SAUGUS_7_LOPEZ	24135	SAUGUS	66	5.34		BC/Ventura		Not modeled Aug NQC	QF/Selfgen
SCE	SHUTLE_6_CREST	24426	SHUTTLE_DI ST	66	0.00	AS	BC/Ventura		Energy Only	Market
SCE	SNCLRA_2_HOWLNG	25080	SANTACLR_D IS	13.8	10.07	EQ	BC/Ventura	S.Clara, Moorpark	Aug NQC	Market
SCE	SNCLRA_2_SPRHYD	25080	SANTACLR_D IS	13.8	0.37	EQ	BC/Ventura	S.Clara, Moorpark	Aug NQC	Market
SCE	SNCLRA_2_UNIT	29952	CAMGEN	13.8	24.49	D1	BC/Ventura	S.Clara, Moorpark	Aug NQC	Market
SCE	SNCLRA_2_UNIT1	24159	WILLAMET	3.8	17.54	D1	BC/Ventura	S.Clara, Moorpark	Aug NQC	Market
SCE	SNCLRA_6_OXGEN	24110	OXGEN	13.8	35.10	D1	BC/Ventura	S.Clara, Moorpark	Aug NQC	QF/Selfgen
SCE	SNCLRA_6_PROCGN	24119	PROCGEN	13.8	45.79	D1	BC/Ventura	S.Clara, Moorpark	Aug NQC	Market
SCE	SNCLRA_6_QF	25080	SANTACLR_D IS	13.8	0.27	EQ	BC/Ventura	S.Clara, Moorpark	Aug NQC	QF/Selfgen
SCE	SPRGVL_2_CREST	25334	SPRNGVL_DI ST	66	0.00	S1	BC/Ventura	Rector, Vestal	Energy Only	Market
SCE	SPRGVL_2_QF	25334	SPRNGVL_DI ST	66	0.12	S1	BC/Ventura	Rector, Vestal	Aug NQC	QF/Selfgen
SCE	SPRGVL_2_TULE	25334	SPRNGVL_DI ST	66	0.00	S1	BC/Ventura	Rector, Vestal	Aug NQC	Market
SCE	SPRGVL_2_TULESC	25334	SPRNGVL_DI ST	66	0.47	S1	BC/Ventura	Rector, Vestal	Aug NQC	Market
SCE	SUNSHN_2_LNDFL	29954	WDT273	13.66	3.34	1	BC/Ventura		Aug NQC	Market
SCE	SUNSHN_2_LNDFL	29954	WDT273	13.66	3.34	2	BC/Ventura		Aug NQC	Market
SCE	SUNSHN_2_LNDFL	29954	WDT273	13.66	3.34	3	BC/Ventura		Aug NQC	Market
SCE	SUNSHN_2_LNDFL	29954	WDT273	13.66	3.34	4	BC/Ventura		Aug NQC	Market
SCE	SUNSHN_2_LNDFL	29954	WDT273	13.66	3.34	5	BC/Ventura		Aug NQC	Market
SCE	SYCAMR_2_UNIT 1	24143	SYCCYN1G	13.8	85.00	1	BC/Ventura		Aug NQC	Net Seller
SCE	SYCAMR_2_UNIT 2	24144	SYCCYN2G	13.8	85.00	2	BC/Ventura		Aug NQC	Net Seller
SCE	SYCAMR_2_UNIT 3	24145	SYCCYN3G	13.8	85.00	3	BC/Ventura		Aug NQC	Net Seller
SCE	SYCAMR_2_UNIT 4	24146	SYCCYN4G	13.8	85.00	4	BC/Ventura		Aug NQC	Net Seller
SCE	TENGEN_2_PL1X2	24148	TENNGEN1	13.8	18.81	D1	BC/Ventura		Aug NQC	Net Seller
SCE	TENGEN_2_PL1X2	24149	TENNGEN2	13.8	18.81	D2	BC/Ventura		Aug NQC	Net Seller
SCE	VESTAL_2_KERN	24372	KR 3-1	11	5.65	1	BC/Ventura	Vestal	Aug NQC	QF/Selfgen
SCE	VESTAL_2_KERN	24373	KR 3-2	11	5.32	2	BC/Ventura	Vestal	Aug NQC	QF/Selfgen
SCE	VESTAL_2_RTS042				0.00		BC/Ventura	Vestal	Not modeled Energy Only	Market

Attachment A - List of physical resources by PTO, local area and market ID

SCE	VESTAL_2_SOLAR1	25064	TULRESLR_1	0.39	8.20	1	BC/Ventura	Vestal	Aug NQC	Solar
SCE	VESTAL_2_SOLAR2	25065	TULRESLR_2	0.39	5.74	1	BC/Ventura	Vestal	Aug NQC	Solar
SCE	VESTAL_2_UNIT1				4.77		BC/Ventura	Vestal	Not modeled Aug NQC	Market
SCE	VESTAL_2_WELLHD	24116	WELLGEN	13.8	49.00	1	BC/Ventura	Vestal		Market
SCE	VESTAL_6_QF	29008	LAKEGEN	13.8	4.18	1	BC/Ventura	Vestal	Aug NQC	QF/Selfgen
SCE	WARNE_2_UNIT	25651	WARNE1	13.8	21.80	1	BC/Ventura		Aug NQC	MUNI
SCE	WARNE_2_UNIT	25652	WARNE2	13.8	21.80	2	BC/Ventura		Aug NQC	MUNI
SCE	ZZ_NA	24340	CHARMIN	13.8	2.80	1	BC/Ventura	S.Clara, Moorpark	No NQC - hist. data	QF/Selfgen
SCE	ZZZZ_APPGEN_6_UNIT 1	24009	APPGEN1G	13.8	0.00	1	BC/Ventura		Retired	Market
SCE	ZZZZ_APPGEN_6_UNIT 1	24010	APPGEN2G	13.8	0.00	2	BC/Ventura		Retired	Market
SCE	ZZZZ_APPGEN_6_UNIT 1	24361	APPGEN3G	13.8	0.00	3	BC/Ventura		Retired	Market
SCE	ZZZZ_MNDALY_7_UNIT 1	24089	MANDLY1G	13.8	0.00	1	BC/Ventura	S.Clara, Moorpark	Retired	Market
SCE	ZZZZ_MNDALY_7_UNIT 2	24090	MANDLY2G	13.8	0.00	2	BC/Ventura	S.Clara, Moorpark	Retired	Market
SCE	ZZZZ_MNDALY_7_UNIT 3	24222	MANDLY3G	16	0.00	3	BC/Ventura	S.Clara, Moorpark	Retired	Market
SCE	ZZZZ_MOORPK_7_UNIT A1	24098	MOORPARK	66	0.00		BC/Ventura	Moorpark	Not modeled Aug NQC	Market
SCE	ZZZZ_SNCLRA_6_WILLM T	24159	WILLAMET	13.8	0.00	D1	BC/Ventura	S.Clara, Moorpark	Replaced by SNCLRA_2_ UNIT1	QF/Selfgen
SCE	ZZZZ_VESTAL_6_ULTRG N	24150	ULTRAGEN	13.8	0.00	1	BC/Ventura	Vestal	Retired	QF/Selfgen
SCE	ALAMIT_7_UNIT 1	24001	ALAMT1 G	18	0.00	1	LA Basin	Western	Retired by 12/31/2019	Market
SCE	ALAMIT_7_UNIT 2	24002	ALAMT2 G	18	0.00	2	LA Basin	Western	Retired by 12/31/2019	Market
SCE	ALAMIT_7_UNIT 3	24003	ALAMT3 G	18	0.00	3	LA Basin	Western	Retired by 2021	Market
SCE	ALAMIT_7_UNIT 4	24004	ALAMT4 G	18	0.00	4	LA Basin	Western	Retired by 2021	Market
SCE	ALAMIT_7_UNIT 5	24005	ALAMT5 G	20	0.00	5	LA Basin	Western	Retired by 2021	Market

Attachment A - List of physical resources by PTO, local area and market ID

SCE	ALAMIT_7_UNIT 6	24161	ALAMT6 G	20	0.00	6	LA Basin	Western	Retired by 12/31/2019	Market
SCE	ALTWD_1_QF	25635	ALTWIND	115	3.82	Q1	LA Basin	Eastern, Valley- Devers	Aug NQC	QF/Selfgen
SCE	ALTWD_1_QF	25635	ALTWIND	115	3.82	Q2	LA Basin	Eastern, Valley- Devers	Aug NQC	QF/Selfgen
SCE	ANAHM_2_CANYN1	25211	CanyonGT 1	13.8	49.40	1	LA Basin	Western		MUNI
SCE	ANAHM_2_CANYN2	25212	CanyonGT 2	13.8	48.00	2	LA Basin	Western		MUNI
SCE	ANAHM_2_CANYN3	25213	CanyonGT 3	13.8	48.00	3	LA Basin	Western		MUNI
SCE	ANAHM_2_CANYN4	25214	CanyonGT 4	13.8	49.40	4	LA Basin	Western		MUNI
SCE	ANAHM_7_CT	25208	DowlingCTG	13.8	40.64	1	LA Basin	Western	Aug NQC	MUNI
SCE	ARCOGN_2_UNITS	24011	ARCO 1G	13.8	52.07	1	LA Basin	Western	Aug NQC	Net Seller
SCE	ARCOGN_2_UNITS	24012	ARCO 2G	13.8	52.07	2	LA Basin	Western	Aug NQC	Net Seller
SCE	ARCOGN_2_UNITS	24013	ARCO 3G	13.8	52.07	3	LA Basin	Western	Aug NQC	Net Seller
SCE	ARCOGN_2_UNITS	24014	ARCO 4G	13.8	52.07	4	LA Basin	Western	Aug NQC	Net Seller
SCE	ARCOGN_2_UNITS	24163	ARCO 5G	13.8	26.03	5	LA Basin	Western	Aug NQC	Net Seller
SCE	ARCOGN_2_UNITS	24164	ARCO 6G	13.8	26.03	6	LA Basin	Western	Aug NQC	Net Seller
SCE	BARRE_2_QF	24016	BARRE	230	0.00		LA Basin	Western	Not modeled	QF/Selfgen
SCE	BARRE_6_PEAKER	29309	BARPKGEN	13.8	47.00	1	LA Basin	Western		Market
SCE	BLAST_1_WIND	24839	BLAST	115	12.99	1	LA Basin	Eastern, Valley- Devers	Aug NQC	Wind
SCE	BUCKWD_1_NPALM1	25634	BUCKWIND	115	0.98		LA Basin	Eastern, Valley- Devers	Not modeled Aug NQC	Wind
SCE	BUCKWD_1_QF	25634	BUCKWIND	115	4.37	QF	LA Basin	Eastern, Valley- Devers	Aug NQC	QF/Selfgen
SCE	BUCKWD_7_WINTCV	25634	BUCKWIND	115	0.35	W5	LA Basin	Eastern, Valley- Devers	Aug NQC	Wind
SCE	CABZON_1_WINDA1	29290	CABAZON	33	10.87	1	LA Basin	Eastern, Valley- Devers	Aug NQC	Wind
SCE	CAPWD_1_QF	25633	CAPWIND	115	5.18	QF	LA Basin	Eastern, Valley- Devers	Aug NQC	QF/Selfgen
SCE	CENTER_2_RHONDO	24203	CENTER S	66	1.91		LA Basin	Western	Not modeled	QF/Selfgen
SCE	CENTER_2_SOLAR1				0.00		LA Basin	Western	Not modeled Energy Only	Solar
SCE	CENTER_2_TECNG1				0.00		LA Basin	Western	Not modeled Energy Only	Market
SCE	CENTER_6_PEAKER	29308	CTRPKGEN	13.8	47.00	1	LA Basin	Western		Market

Attachment A - List of physical resources by PTO, local area and market ID

SCE	CENTRY_6_PL1X4	25302	CLTNCTRY	13.8	36.00	1	LA Basin	Eastern	Aug NQC	MUNI
SCE	CHEVMN_2_UNITS	24022	CHEVGEN1	13.8	4.61	1	LA Basin	Western, El Nido	Aug NQC	Net Seller
SCE	CHEVMN_2_UNITS	24023	CHEVGEN2	13.8	4.61	2	LA Basin	Western, El Nido	Aug NQC	Net Seller
SCE	CHINO_2_APEBT1	25180	WDT1250BES S_	0.48	20.00	1	LA Basin	Eastern	Aug NQC	Battery
SCE	CHINO_2_JURUPA				0.00		LA Basin	Eastern	Not modeled Energy Only	Market
SCE	CHINO_2_QF				0.58		LA Basin	Eastern	Not modeled Aug NQC	QF/Selfgen
SCE	CHINO_2_SASOLR				0.00		LA Basin	Eastern	Not modeled Energy Only	Solar
SCE	CHINO_2_SOLAR				0.41		LA Basin	Eastern	Not modeled	Solar
SCE	CHINO_2_SOLAR2				0.00		LA Basin	Eastern	Not modeled Energy Only	Solar
SCE	CHINO_6_CIMGEN	24026	CIMGEN	13.8	25.51	D1	LA Basin	Eastern	Aug NQC	QF/Selfgen
SCE	CHINO_6_SMPPAP	24140	SIMPSON	13.8	22.78	D1	LA Basin	Eastern	Aug NQC	QF/Selfgen
SCE	CHINO_7_MILIKN	24024	CHINO	66	1.19		LA Basin	Eastern	Not modeled Aug NQC	Market
SCE	COLTON_6_AGUAM1	25303	CLTNAGUA	13.8	43.00	1	LA Basin	Eastern	Aug NQC	MUNI
SCE	CORONS_2_SOLAR				0.00		LA Basin	Eastern	Not modeled Energy Only	Solar
SCE	CORONS_6_CLRWTR	29338	CLRWTRCT	13.8	20.72	G1	LA Basin	Eastern		MUNI
SCE	CORONS_6_CLRWTR	29340	CLRWTRST	13.8	7.28	S1	LA Basin	Eastern		MUNI
SCE	DELAMO_2_SOLAR1				0.62		LA Basin	Western	Not modeled Aug NQC	Solar
SCE	DELAMO_2_SOLAR2				0.72		LA Basin	Western	Not modeled Aug NQC	Solar
SCE	DELAMO_2_SOLAR3				0.51		LA Basin	Western	Not modeled Aug NQC	Solar
SCE	DELAMO_2_SOLAR4				0.53		LA Basin	Western	Not modeled Aug NQC	Solar
SCE	DELAMO_2_SOLAR5				0.41		LA Basin	Western	Not modeled Aug NQC	Solar
SCE	DELAMO_2_SOLAR6				0.82		LA Basin	Western	Not modeled Aug NQC	Solar
SCE	DELAMO_2_SOLRC1				0.00		LA Basin	Western	Not modeled Energy Only	Solar

Attachment A - List of physical resources by PTO, local area and market ID

SCE	DELAMO_2_SOLRD				0.00		LA Basin	Western	Not modeled Energy Only	Solar
SCE	DEVERS_1_QF	25632	TERAWND	115	8.63	QF	LA Basin	Eastern, Valley-Devers	Aug NQC	QF/Selfgen
SCE	DEVERS_1_QF	25639	SEAWIND	115	10.35	QF	LA Basin	Eastern, Valley-Devers	Aug NQC	QF/Selfgen
SCE	DEVERS_1_SEPV05				0.00		LA Basin	Eastern, Valley-Devers	Not modeled Energy Only	Market
SCE	DEVERS_1_SOLAR				0.00		LA Basin	Eastern, Valley-Devers	Not modeled Energy Only	Solar
SCE	DEVERS_1_SOLAR1				0.00		LA Basin	Eastern, Valley-Devers	Not modeled Energy Only	Solar
SCE	DEVERS_1_SOLAR2				0.00		LA Basin	Eastern, Valley-Devers	Not modeled Energy Only	Solar
SCE	DEVERS_2_CS2SR4				0.00		LA Basin	Eastern, Valley-Devers	Not modeled Energy Only	Solar
SCE	DEVERS_2_DHSPG2				0.00		LA Basin	Eastern, Valley-Devers	Not modeled Energy Only	Market
SCE	DMDVLY_1_UNITS	25425	ESRP P2	6.9	1.64	8	LA Basin	Eastern	Aug NQC	QF/Selfgen
SCE	DREWS_6_PL1X4	25301	CLTNDREW	13.8	36.00	1	LA Basin	Eastern	Aug NQC	MUNI
SCE	DVLCYN_1_UNITS	25648	DVLCYN1G	13.8	39.40	1	LA Basin	Eastern	Aug NQC	MUNI
SCE	DVLCYN_1_UNITS	25649	DVLCYN2G	13.8	39.40	2	LA Basin	Eastern	Aug NQC	MUNI
SCE	DVLCYN_1_UNITS	25603	DVLCYN3G	13.8	52.54	3	LA Basin	Eastern	Aug NQC	MUNI
SCE	DVLCYN_1_UNITS	25604	DVLCYN4G	13.8	52.54	4	LA Basin	Eastern	Aug NQC	MUNI
SCE	ELLIS_2_QF	24325	ORCOGEN	13.8	0.04	1	LA Basin	Western	Aug NQC	QF/Selfgen
SCE	ELSEGN_2_UN1011	29904	ELSEG5GT	16.5	131.50	5	LA Basin	Western, El Nido	Aug NQC	Market
SCE	ELSEGN_2_UN1011	29903	ELSEG6ST	13.8	131.50	6	LA Basin	Western, El Nido	Aug NQC	Market
SCE	ELSEGN_2_UN2021	29902	ELSEG7GT	16.5	131.84	7	LA Basin	Western, El Nido	Aug NQC	Market
SCE	ELSEGN_2_UN2021	29901	ELSEG8ST	13.8	131.84	8	LA Basin	Western, El Nido	Aug NQC	Market
SCE	ETIWND_2_CHMPNE				0.00		LA Basin	Eastern	Not modeled Energy Only	Market
SCE	ETIWND_2_FONTNA	24055	ETIWANDA	66	0.22		LA Basin	Eastern	Not modeled Aug NQC	QF/Selfgen
SCE	ETIWND_2_RTS010	24055	ETIWANDA	66	0.62		LA Basin	Eastern	Not modeled Aug NQC	Market
SCE	ETIWND_2_RTS015	24055	ETIWANDA	66	1.23		LA Basin	Eastern	Not modeled Aug NQC	Market

Attachment A - List of physical resources by PTO, local area and market ID

SCE	ETIWND_2_RTS017	24055	ETIWANDA	66	1.44		LA Basin	Eastern	Not modeled Aug NQC	Market
SCE	ETIWND_2_RTS018	24055	ETIWANDA	66	0.62		LA Basin	Eastern	Not modeled Aug NQC	Market
SCE	ETIWND_2_RTS023	24055	ETIWANDA	66	1.03		LA Basin	Eastern	Not modeled Aug NQC	Market
SCE	ETIWND_2_RTS026	24055	ETIWANDA	66	2.46		LA Basin	Eastern	Not modeled Aug NQC	Market
SCE	ETIWND_2_RTS027	24055	ETIWANDA	66	0.82		LA Basin	Eastern	Not modeled Aug NQC	Market
SCE	ETIWND_2_SOLAR1				0.00		LA Basin	Eastern	Not modeled Energy Only	Solar
SCE	ETIWND_2_SOLAR2				0.00		LA Basin	Eastern	Not modeled Energy Only	Solar
SCE	ETIWND_2_SOLAR5				0.00		LA Basin	Eastern	Not modeled Energy Only	Solar
SCE	ETIWND_2_UNIT1	24071	INLAND	13.8	16.88	1	LA Basin	Eastern	Aug NQC	QF/Selfgen
SCE	ETIWND_6_GRPLND	29305	ETWPKGEN	13.8	46.00	1	LA Basin	Eastern		Market
SCE	ETIWND_6_MWDETI	25422	ETI MWDG	13.8	5.94	1	LA Basin	Eastern	Aug NQC	Market
SCE	GARNET_1_SOLAR	24815	GARNET	115	0.00		LA Basin	Eastern, Valley- Devers	Not modeled Energy Only	Solar
SCE	GARNET_1_SOLAR2	24815	GARNET	115	1.64		LA Basin	Eastern, Valley- Devers	Not modeled Aug NQC	Solar
SCE	GARNET_1_UNITS	24815	GARNET	115	2.06	G1	LA Basin	Eastern, Valley- Devers	Aug NQC	Market
SCE	GARNET_1_UNITS	24815	GARNET	115	0.71	G2	LA Basin	Eastern, Valley- Devers	Aug NQC	Market
SCE	GARNET_1_UNITS	24815	GARNET	115	1.61	G3	LA Basin	Eastern, Valley- Devers	Aug NQC	Market
SCE	GARNET_1_WIND	24815	GARNET	115	1.72		LA Basin	Eastern, Valley- Devers	Not modeled Aug NQC	Wind
SCE	GARNET_1_WINDS	24815	GARNET	115	5.96	W2	LA Basin	Eastern, Valley- Devers	Aug NQC	Wind
SCE	GARNET_1_WT3WND	24815	GARNET	115	0.00	W3	LA Basin	Eastern, Valley- Devers	Aug NQC	Market
SCE	GARNET_2_DIFWD1	24815	GARNET	115	2.09		LA Basin	Eastern, Valley- Devers	Aug NQC	Market
SCE	GARNET_2_HYDRO	24815	GARNET	115	0.80	QF	LA Basin	Eastern, Valley- Devers	Aug NQC	Market

Attachment A - List of physical resources by PTO, local area and market ID

SCE	GARNET_2_WIND1	24815	GARNET	115	2.97		LA Basin	Eastern, Valley-Devers	Not modeled Aug NQC	Wind
SCE	GARNET_2_WIND2	24815	GARNET	115	3.10		LA Basin	Eastern, Valley-Devers	Not modeled Aug NQC	Wind
SCE	GARNET_2_WIND3	24815	GARNET	115	3.34		LA Basin	Eastern, Valley-Devers	Not modeled Aug NQC	Wind
SCE	GARNET_2_WIND4	24815	GARNET	115	2.60		LA Basin	Eastern, Valley-Devers	Not modeled Aug NQC	Wind
SCE	GARNET_2_WIND5	24815	GARNET	115	0.80		LA Basin	Eastern, Valley-Devers	Not modeled Aug NQC	Wind
SCE	GARNET_2_WPMWD6	24815	GARNET	115	1.57		LA Basin	Eastern, Valley-Devers	Not modeled Aug NQC	Wind
SCE	GLNARM_2_UNIT 5	29013	GLENNARM5_CT	13.8	50.00	CT	LA Basin	Western		MUNI
SCE	GLNARM_2_UNIT 5	29014	GLENNARM5_ST	13.8	15.00	ST	LA Basin	Western		MUNI
SCE	GLNARM_7_UNIT 1	29005	PASADNA1	13.8	22.07	1	LA Basin	Western		MUNI
SCE	GLNARM_7_UNIT 2	29006	PASADNA2	13.8	22.30	1	LA Basin	Western		MUNI
SCE	GLNARM_7_UNIT 3	25042	PASADNA3	13.8	44.83	1	LA Basin	Western		MUNI
SCE	GLNARM_7_UNIT 4	25043	PASADNA4	13.8	42.42	1	LA Basin	Western		MUNI
SCE	HARBGN_7_UNITS	24062	HARBOR G	13.8	76.27	1	LA Basin	Western		Market
SCE	HARBGN_7_UNITS	24062	HARBOR G	13.8	11.86	HP	LA Basin	Western		Market
SCE	HARBGN_7_UNITS	25510	HARBORG4	4.16	11.86	LP	LA Basin	Western		Market
SCE	HINSON_6_CARBG	24020	CARBGEN1	13.8	14.78	1	LA Basin	Western	Aug NQC	Market
SCE	HINSON_6_CARBG	24328	CARBGEN2	13.8	14.78	1	LA Basin	Western	Aug NQC	Market
SCE	HINSON_6_LBECH1	24170	LBEACH12	13.8	65.00	1	LA Basin	Western		Market
SCE	HINSON_6_LBECH2	24170	LBEACH12	13.8	65.00	2	LA Basin	Western		Market
SCE	HINSON_6_LBECH3	24171	LBEACH34	13.8	65.00	3	LA Basin	Western		Market
SCE	HINSON_6_LBECH4	24171	LBEACH34	13.8	65.00	4	LA Basin	Western		Market
SCE	HINSON_6_SERRGN	24139	SERRFGEN	13.8	28.93	D1	LA Basin	Western	Aug NQC	Market
SCE	HNTGBH_7_UNIT 1	24066	HUNT1 G	13.8	0.00	1	LA Basin	Western	Retired by 12/31/2019	Market
SCE	HNTGBH_7_UNIT 2	24067	HUNT2 G	13.8	0.00	2	LA Basin	Western	Retired by 2021	Market
SCE	INDIGO_1_UNIT 1	29190	WINTECX2	13.8	42.00	1	LA Basin	Eastern, Valley-Devers		Market
SCE	INDIGO_1_UNIT 2	29191	WINTECX1	13.8	42.00	1	LA Basin	Eastern, Valley-Devers		Market

Attachment A - List of physical resources by PTO, local area and market ID

SCE	INDIGO_1_UNIT 3	29180	WINTEC8	13.8	42.00	1	LA Basin	Eastern, Valley-Devers		Market
SCE	INLDEM_5_UNIT 1	29041	IIEEC-G1	19.5	335.00	1	LA Basin	Eastern, Valley, Valley-Devers	Aug NQC	Market
SCE	INLDEM_5_UNIT 2	29042	IIEEC-G2	19.5	335.00	1	LA Basin	Eastern, Valley, Valley-Devers	Mothballed	Market
SCE	LACIEN_2_VENICE	24337	VENICE	13.8	0.00	1	LA Basin	Western, El Nido	Aug NQC	MUNI
SCE	LAGBEL_6_QF	29951	REFUSE	13.8	0.35	D1	LA Basin	Western	Aug NQC	QF/Selfgen
SCE	LGHTHP_6_ICEGEN	24070	ICEGEN	13.8	48.00	1	LA Basin	Western	Aug NQC	QF/Selfgen
SCE	MESAS_2_QF	24209	MESA CAL	66	0.00		LA Basin	Western	Not modeled Aug NQC	QF/Selfgen
SCE	MIRLOM_2_CORONA				1.70		LA Basin	Eastern	Not modeled Aug NQC	QF/Selfgen
SCE	MIRLOM_2_LNDFL				1.23		LA Basin	Eastern	Not modeled Aug NQC	Market
SCE	MIRLOM_2_MLBBTA	25185	WDT1425_G1	0.48	10.00	1	LA Basin	Eastern	Aug NQC	Battery
SCE	MIRLOM_2_MLBBTB	25186	WDT1426_G2	0.48	10.00	1	LA Basin	Eastern	Aug NQC	Battery
SCE	MIRLOM_2_ONTARO				2.26		LA Basin	Eastern	Not modeled Aug NQC	Market
SCE	MIRLOM_2_RTS032				0.62		LA Basin	Eastern	Not modeled Aug NQC	Market
SCE	MIRLOM_2_RTS033				0.41		LA Basin	Eastern	Not modeled Aug NQC	Market
SCE	MIRLOM_2_TEMESC				1.07		LA Basin	Eastern	Not modeled Aug NQC	QF/Selfgen
SCE	MIRLOM_6_PEAKEK	29307	MRLPKGEN	13.8	46.00	1	LA Basin	Eastern		Market
SCE	MIRLOM_7_MWDLKM	24210	MIRALOMA	66	5.00		LA Basin	Eastern	Not modeled Aug NQC	MUNI
SCE	MOJAVE_1_SIPHON	25657	MJVSPHN1	13.8	4.04	1	LA Basin	Eastern	Aug NQC	Market
SCE	MOJAVE_1_SIPHON	25658	MJVSPHN1	13.8	4.04	2	LA Basin	Eastern	Aug NQC	Market
SCE	MOJAVE_1_SIPHON	25659	MJVSPHN1	13.8	4.04	3	LA Basin	Eastern	Aug NQC	Market
SCE	MTWIND_1_UNIT 1	29060	MOUNTWND	115	11.77	S1	LA Basin	Eastern, Valley-Devers	Aug NQC	Wind
SCE	MTWIND_1_UNIT 2	29060	MOUNTWND	115	5.88	S2	LA Basin	Eastern, Valley-Devers	Aug NQC	Wind
SCE	MTWIND_1_UNIT 3	29060	MOUNTWND	115	5.95	S3	LA Basin	Eastern, Valley-Devers	Aug NQC	Wind
SCE	OLINDA_2_COYCRK	24211	OLINDA	66	3.13		LA Basin	Western	Not modeled	QF/Selfgen

Attachment A - List of physical resources by PTO, local area and market ID

SCE	OLINDA_2_LNDFL2	29011	BREAPWR2	13.8	4.07	C1	LA Basin	Western	Aug NQC	Market
SCE	OLINDA_2_LNDFL2	29011	BREAPWR2	13.8	4.07	C2	LA Basin	Western	Aug NQC	Market
SCE	OLINDA_2_LNDFL2	29011	BREAPWR2	13.8	4.07	C3	LA Basin	Western	Aug NQC	Market
SCE	OLINDA_2_LNDFL2	29011	BREAPWR2	13.8	4.07	C4	LA Basin	Western	Aug NQC	Market
SCE	OLINDA_2_LNDFL2	29011	BREAPWR2	13.8	7.28	S1	LA Basin	Western	Aug NQC	Market
SCE	OLINDA_2_QF	24211	OLINDA	66	0.01		LA Basin	Western	Not modeled Aug NQC	QF/Selfgen
SCE	OLINDA_7_BLKSNL	24211	OLINDA	66	0.41		LA Basin	Western	Not modeled Aug NQC	Market
SCE	OLINDA_7_LNDFIL	24211	OLINDA	66	0.00		LA Basin	Western	Not modeled Aug NQC	QF/Selfgen
SCE	PADUA_2_ONTARO	24111	PADUA	66	0.35		LA Basin	Eastern	Not modeled Aug NQC	QF/Selfgen
SCE	PADUA_2_SOLAR1	24111	PADUA	66	0.00		LA Basin	Eastern	Not modeled Energy Only	Solar
SCE	PADUA_6_MWSDSM	24111	PADUA	66	2.74		LA Basin	Eastern	Not modeled Aug NQC	MUNI
SCE	PADUA_6_QF	24111	PADUA	66	0.38		LA Basin	Eastern	Not modeled Aug NQC	QF/Selfgen
SCE	PADUA_7_SDIMAS	24111	PADUA	66	1.05		LA Basin	Eastern	Not modeled Aug NQC	Market
SCE	PANSEA_1_PANARO	25640	PANAERO	115	7.95	QF	LA Basin	Eastern, Valley-Devers	Aug NQC	Wind
SCE	PWEST_1_UNIT	24815	GARNET	115	0.56	PC	LA Basin	Western	Aug NQC	Market
SCE	REDOND_7_UNIT 5	24121	REDON5 G	18	0.00	5	LA Basin	Western	Retired by 2021	Market
SCE	REDOND_7_UNIT 6	24122	REDON6 G	18	0.00	6	LA Basin	Western	Retired by 2021	Market
SCE	REDOND_7_UNIT 7	24123	REDON7 G	20	0.00	7	LA Basin	Western	Retired by 12/31/2019	Market
SCE	REDOND_7_UNIT 8	24124	REDON8 G	20	0.00	8	LA Basin	Western	Retired by 2021	Market
SCE	RENWD_1_QF	25636	RENWIND	115	1.33	Q1	LA Basin	Eastern, Valley-Devers	Aug NQC	QF/Selfgen
SCE	RENWD_1_QF	25636	RENWIND	115	1.32	Q2	LA Basin	Eastern, Valley-Devers	Aug NQC	QF/Selfgen
SCE	RHONDO_6_PUENTE	24213	RIOHONDO	66	0.00		LA Basin	Western	Not modeled Aug NQC	Net Seller

Attachment A - List of physical resources by PTO, local area and market ID

SCE	RVSIIDE_2_RERCU3	24299	RERC2G3	13.8	48.50	1	LA Basin	Eastern		MUNI
SCE	RVSIIDE_2_RERCU4	24300	RERC2G4	13.8	48.50	1	LA Basin	Eastern		MUNI
SCE	RVSIIDE_6_RERCU1	24242	RERC1G	13.8	48.35	1	LA Basin	Eastern		MUNI
SCE	RVSIIDE_6_RERCU2	24243	RERC2G	13.8	48.50	1	LA Basin	Eastern		MUNI
SCE	RVSIIDE_6_SOLAR1	24244	SPRINGEN	13.8	3.08		LA Basin	Eastern	Not modeled Aug NQC	Solar
SCE	RVSIIDE_6_SPRING	24244	SPRINGEN	13.8	36.00	1	LA Basin	Eastern		Market
SCE	SANITR_6_UNITS	24324	SANIGEN	13.8	42.00	D1	LA Basin	Eastern	Aug NQC	QF/Selfgen
SCE	SANTGO_2_LNDFL1	24341	COYGEN	13.8	19.16	1	LA Basin	Western	Aug NQC	Market
SCE	SANTGO_2_MABBT1	25192	WDT1406_G	0.48	2.00	1	LA Basin	Western	Aug NQC	Battery
SCE	SANWD_1_QF	25646	SANWIND	115	4.11	Q1	LA Basin	Eastern, Valley- Devers	Aug NQC	Wind
SCE	SANWD_1_QF	25646	SANWIND	115	4.11	Q2	LA Basin	Eastern, Valley- Devers	Aug NQC	Wind
SCE	SBERDO_2_PSP3	24921	MNTV-CT1	18	140.56	1	LA Basin	Eastern, West of Devers		Market
SCE	SBERDO_2_PSP3	24922	MNTV-CT2	18	140.56	1	LA Basin	Eastern, West of Devers		Market
SCE	SBERDO_2_PSP3	24923	MNTV-ST1	18	243.89	1	LA Basin	Eastern, West of Devers		Market
SCE	SBERDO_2_PSP4	24924	MNTV-CT3	18	140.56	1	LA Basin	Eastern, West of Devers		Market
SCE	SBERDO_2_PSP4	24925	MNTV-CT4	18	140.56	1	LA Basin	Eastern, West of Devers		Market
SCE	SBERDO_2_PSP4	24926	MNTV-ST2	18	243.89	1	LA Basin	Eastern, West of Devers		Market
SCE	SBERDO_2_QF	24214	SANBRDNO	66	0.26		LA Basin	Eastern, West of Devers	Not modeled Aug NQC	QF/Selfgen
SCE	SBERDO_2_REDLND	24214	SANBRDNO	66	0.82		LA Basin	Eastern, West of Devers	Not modeled Aug NQC	Market
SCE	SBERDO_2_RTS005	24214	SANBRDNO	66	1.03		LA Basin	Eastern, West of Devers	Not modeled Aug NQC	Market
SCE	SBERDO_2_RTS007	24214	SANBRDNO	66	1.03		LA Basin	Eastern, West of Devers	Not modeled Aug NQC	Market
SCE	SBERDO_2_RTS011	24214	SANBRDNO	66	1.44		LA Basin	Eastern, West of Devers	Not modeled Aug NQC	Market
SCE	SBERDO_2_RTS013	24214	SANBRDNO	66	1.44		LA Basin	Eastern, West of Devers	Not modeled Aug NQC	Market

Attachment A - List of physical resources by PTO, local area and market ID

SCE	SBERDO_2_RTS016	24214	SANBRDNO	66	0.62		LA Basin	Eastern, West of Devers	Not modeled Aug NQC	Market
SCE	SBERDO_2_RTS048	24214	SANBRDNO	66	0.00		LA Basin	Eastern, West of Devers	Not modeled Energy Only	Market
SCE	SBERDO_2_SNTANA	24214	SANBRDNO	66	0.32		LA Basin	Eastern, West of Devers	Not modeled Aug NQC	QF/Selfgen
SCE	SBERDO_6_MILLCK	24214	SANBRDNO	66	1.04		LA Basin	Eastern, West of Devers	Not modeled Aug NQC	QF/Selfgen
SCE	SENTNL_2_CTG1	29101	SENTINEL_G 1	13.8	103.76	1	LA Basin	Eastern, Valley-Devers		Market
SCE	SENTNL_2_CTG2	29102	SENTINEL_G 2	13.8	95.34	1	LA Basin	Eastern, Valley-Devers		Market
SCE	SENTNL_2_CTG3	29103	SENTINEL_G 3	13.8	96.85	1	LA Basin	Eastern, Valley-Devers		Market
SCE	SENTNL_2_CTG4	29104	SENTINEL_G 4	13.8	102.47	1	LA Basin	Eastern, Valley-Devers		Market
SCE	SENTNL_2_CTG5	29105	SENTINEL_G 5	13.8	103.81	1	LA Basin	Eastern, Valley-Devers		Market
SCE	SENTNL_2_CTG6	29106	SENTINEL_G 6	13.8	100.99	1	LA Basin	Eastern, Valley-Devers		Market
SCE	SENTNL_2_CTG7	29107	SENTINEL_G 7	13.8	97.06	1	LA Basin	Eastern, Valley-Devers		Market
SCE	SENTNL_2_CTG8	29108	SENTINEL_G 8	13.8	101.80	1	LA Basin	Eastern, Valley-Devers		Market
SCE	TIFFNY_1_DILLON	29021	WINTEC6	115	11.93	1	LA Basin	Eastern, Valley-Devers	Aug NQC	Wind
SCE	TRNSWD_1_QF	25637	TRANWIND	115	10.33	QF	LA Basin	Eastern, Valley-Devers	Aug NQC	Wind
SCE	TULEWD_1_TULWD1				33.81		LA Basin	Eastern, Valley-Devers	Not modeled Aug NQC	Wind
SCE	VALLEY_5_PERRIS	24160	VALLEYSC	115	7.94		LA Basin	Eastern, Valley, Valley-Devers	Not modeled Aug NQC	QF/Selfgen
SCE	VALLEY_5_REDMTN	24160	VALLEYSC	115	3.50		LA Basin	Eastern, Valley, Valley-Devers	Not modeled Aug NQC	QF/Selfgen
SCE	VALLEY_5_RTS044	24160	VALLEYSC	115	3.28		LA Basin	Eastern, Valley, Valley-Devers	Not modeled Aug NQC	Market
SCE	VALLEY_5_SOLAR1	24160	VALLEYSC	115	0.00		LA Basin	Eastern, Valley, Valley-Devers	Not modeled Energy Only	Solar
SCE	VALLEY_5_SOLAR2	25082	WDT786	34.5	8.20	EQ	LA Basin	Eastern, Valley, Valley-Devers	Aug NQC	Solar

Attachment A - List of physical resources by PTO, local area and market ID

SCE	VENWD_1_WIND1	25645	VENWIND	115	2.50	Q1	LA Basin	Eastern, Valley-Devers	Aug NQC	QF/Selfgen
SCE	VENWD_1_WIND2	25645	VENWIND	115	4.25	Q2	LA Basin	Eastern, Valley-Devers	Aug NQC	QF/Selfgen
SCE	VENWD_1_WIND3	25645	VENWIND	115	5.05	EU	LA Basin	Eastern, Valley-Devers	Aug NQC	QF/Selfgen
SCE	VERNON_6_GONZL1	24342	FEDGEN	13.8	5.75	1	LA Basin	Western		MUNI
SCE	VERNON_6_GONZL2	24342	FEDGEN	13.8	5.75	1	LA Basin	Western		MUNI
SCE	VERNON_6_MALBRG	24239	MALBRG1G	13.8	42.37	C1	LA Basin	Western		MUNI
SCE	VERNON_6_MALBRG	24240	MALBRG2G	13.8	42.37	C2	LA Basin	Western		MUNI
SCE	VERNON_6_MALBRG	24241	MALBRG3G	13.8	49.26	S3	LA Basin	Western		MUNI
SCE	VILLPK_2_VALLYV	24216	VILLA PK	66	4.10	DG	LA Basin	Western	Aug NQC	QF/Selfgen
SCE	VILLPK_6_MWDYOR	24216	VILLA PK	66	3.99		LA Basin	Western	Not modeled Aug NQC	MUNI
SCE	VISTA_2_RIALTO	24901	VSTA	230	0.41		LA Basin	Eastern	Not modeled	Market
SCE	VISTA_2_RTS028	24901	VSTA	230	1.44		LA Basin	Eastern	Not modeled Aug NQC	Market
SCE	VISTA_6_QF	24902	VSTA	66	0.06		LA Basin	Eastern	Not modeled Aug NQC	QF/Selfgen
SCE	WALCRK_2_CTG1	29201	WALCRKG1	13.8	96.00	1	LA Basin	Western		Market
SCE	WALCRK_2_CTG2	29202	WALCRKG2	13.8	96.00	1	LA Basin	Western		Market
SCE	WALCRK_2_CTG3	29203	WALCRKG3	13.8	96.00	1	LA Basin	Western		Market
SCE	WALCRK_2_CTG4	29204	WALCRKG4	13.8	96.00	1	LA Basin	Western		Market
SCE	WALCRK_2_CTG5	29205	WALCRKG5	13.8	96.65	1	LA Basin	Western		Market
SCE	WALNUT_2_SOLAR				0.00		LA Basin	Western	Not modeled Energy Only	Solar
SCE	WALNUT_6_HILLGEN	24063	HILLGEN	13.8	39.44	D1	LA Basin	Western	Aug NQC	Net Seller
SCE	WALNUT_7_WCOVCT	24157	WALNUT	66	3.45		LA Basin	Western	Not modeled Aug NQC	Market
SCE	WALNUT_7_WCOVST	24157	WALNUT	66	5.61		LA Basin	Western	Not modeled Aug NQC	Market
SCE	WHTWTR_1_WINDA1	29061	WHITEWTR	33	16.30	1	LA Basin	Eastern, Valley-Devers	Aug NQC	Wind
SCE	ZZ_ARCOGN_2_UNITS	24018	BRIGEN	13.8	0.00	1	LA Basin	Western	No NQC - hist. data	Net Seller
SCE	ZZ_HINSON_6_QF	24064	HINSON	66	0.00	1	LA Basin	Western	No NQC - hist. data	QF/Selfgen

Attachment A - List of physical resources by PTO, local area and market ID

SCE	ZZ_LAFRES_6_QF	24332	PALOGEN	13.8	0.00	D1	LA Basin	Western, El Nido	No NQC - hist. data	QF/Selfgen
SCE	ZZ_MOBGEN_6_UNIT 1	24094	MOBGEN	13.8	0.00	1	LA Basin	Western, El Nido	No NQC - hist. data	QF/Selfgen
SCE	ZZ_NA	24327	THUMSGEN	13.8	0.00	1	LA Basin	Western	No NQC - hist. data	QF/Selfgen
SCE	ZZ_NA	24329	MOBGEN2	13.8	0.00	1	LA Basin	Western, El Nido	No NQC - hist. data	QF/Selfgen
SCE	ZZ_NA	24330	OUTFALL1	13.8	0.00	1	LA Basin	Western, El Nido	No NQC - hist. data	QF/Selfgen
SCE	ZZ_NA	24331	OUTFALL2	13.8	0.00	1	LA Basin	Western, El Nido	No NQC - hist. data	QF/Selfgen
SCE	ZZ_NA	29260	ALTAMSA4	115	0.00	1	LA Basin	Eastern, Valley-Devers	No NQC - hist. data	Wind
SCE	ZZZ_New	97624	WH_STN_1	13.8	49.00	1	LA Basin	Western	No NQC - Pmax	Market
SCE	ZZZ_New	97625	WH_STN_2	13.8	49.00	1	LA Basin	Western	No NQC - Pmax	Market
SCE	ZZZ_New	24575	ALMT CTG1	18	200.00	G1	LA Basin	Western	No NQC - Pmax	Market
SCE	ZZZ_New	24580	HUNTBCH CTG1	18	202.00	G1	LA Basin	Western	No NQC - Pmax	Market
SCE	ZZZ_New	24576	ALMT CTG2	18	200.00	G2	LA Basin	Western	No NQC - Pmax	Market
SCE	ZZZ_New	24581	HUNTBCH CTG2	18	202.00	G2	LA Basin	Western	No NQC - Pmax	Market
SCE	ZZZ_New	24577	ALMT STG	18	240.00	S1	LA Basin	Western	No NQC - Pmax	Market
SCE	ZZZ_New	24582	HUNTBCH STG	18	240.00	S1	LA Basin	Western	No NQC - Pmax	Market
SCE	ZZZZ_BRDWAY_7_UNIT 3	29007	BRODWYSC	13.8	0.00		LA Basin	Western	Retired	MUNI
SCE	ZZZZ_CENTER_2_QF	29953	SIGGEN	13.8	0.00	D1	LA Basin	Western	Aug NQC	QF/Selfgen
SCE	ZZZZ_ETIWND_7_MIDVLY	24055	ETIWANDA	66	0.00		LA Basin	Eastern	Not modeled Aug NQC	QF/Selfgen
SCE	ZZZZ_ETIWND_7_UNIT 3	24052	MTNVIST3	18	0.00	3	LA Basin	Eastern	Retired	Market
SCE	ZZZZ_ETIWND_7_UNIT 4	24053	MTNVIST4	18	0.00	4	LA Basin	Eastern	Retired	Market

Attachment A - List of physical resources by PTO, local area and market ID

SCE	ZZZZ_LAGBEL_2_STG1				0.00		LA Basin	Western	Retired	Market
SCE	ZZZZ_MIRLOM_6_DELGEN	29339	DELGEN	13.8	0.00	1	LA Basin	Eastern	Aug NQC	QF/Selfgen
SCE	ZZZZ_RHONDO_2_QF	24213	RIOHONDO	66	0.00	DG	LA Basin	Western	Aug NQC	QF/Selfgen
SCE	ZZZZ_VALLEY_7_BADLND	24160	VALLEYSC	115	0.00		LA Basin	Eastern, Valley, Valley-Devers	Retired	Market
SCE	ZZZZ_VALLEY_7_UNITA1	24160	VALLEYSC	115	0.00		LA Basin	Eastern, Valley, Valley-Devers	Not modeled Aug NQC	Market
SCE	ZZZZZ_ELSEGN_7_UNIT4	24048	ELSEG4 G	18	0.00	4	LA Basin	Western, El Nido	Retired	Market
SDG&E	BORDER_6_UNITA1	22149	CALPK_BD	13.8	48.00	1	SD-IV	San Diego, Border		Market
SDG&E	BREGGO_6_DEGRSL	22085	BORREGO	12.5	2.58	DG	SD-IV	San Diego	Aug NQC	Solar
SDG&E	BREGGO_6_SOLAR	22082	BR GEN1	0.21	10.66	1	SD-IV	San Diego	Aug NQC	Solar
SDG&E	CARLS1_2_CARCT1	22783	EA5 REPOWER1	13.8	105.50	1	SD-IV	San Diego	Aug NQC	Market
SDG&E	CARLS1_2_CARCT1	22784	EA5 REPOWER2	13.8	105.50	1	SD-IV	San Diego	Aug NQC	Market
SDG&E	CARLS1_2_CARCT1	22786	EA5 REPOWER4	13.8	105.50	1	SD-IV	San Diego	Aug NQC	Market
SDG&E	CARLS1_2_CARCT1	22788	EA5 REPOWER3	13.8	105.50	1	SD-IV	San Diego	Aug NQC	Market
SDG&E	CARLS2_1_CARCT1	22787	EA5 REPOWER5	13.8	105.50	1	SD-IV	San Diego	Aug NQC	Market
SDG&E	CCRITA_7_RPPCHF	22124	CHCARITA	138	2.31	1	SD-IV	San Diego	Aug NQC	Market
SDG&E	CHILLS_1_SYCENG	22120	CARLTNHS	138	0.71	1	SD-IV	San Diego	Aug NQC	QF/Selfgen
SDG&E	CHILLS_7_UNITA1	22120	CARLTNHS	138	1.52	2	SD-IV	San Diego	Aug NQC	QF/Selfgen
SDG&E	CNTNLA_2_SOLAR1	23463	DW GEN3&4	0.33	51.25	1	SD-IV		Aug NQC	Solar
SDG&E	CNTNLA_2_SOLAR2	23463	DW GEN3&4	0.33	0.00	2	SD-IV		Energy Only	Solar
SDG&E	CPSTNO_7_PRMADS	22112	CAPSTRNO	138	5.88	1	SD-IV	San Diego	Aug NQC	Market
SDG&E	CPVERD_2_SOLAR	23309	IV GEN3 G1	0.31	31.66	G1	SD-IV		Aug NQC	Solar
SDG&E	CPVERD_2_SOLAR	23301	IV GEN3 G2	0.31	25.33	G2	SD-IV		Aug NQC	Solar
SDG&E	CRELMN_6_RAMON1	22152	CREELMAN	69	0.82	DG	SD-IV	San Diego	Aug NQC	Solar
SDG&E	CRELMN_6_RAMON2	22152	CREELMAN	69	2.05	DG	SD-IV	San Diego	Aug NQC	Solar
SDG&E	CRELMN_6_RAMSR3				1.42		SD-IV	San Diego	Not modeled Aug NQC	Solar
SDG&E	CRSTWD_6_KUMYAY	22915	KUMEYAAY	0.69	13.25	1	SD-IV	San Diego	Aug NQC	Wind
SDG&E	CSLR4S_2_SOLAR	23298	DW GEN1 G1	0.315	26.65	G1	SD-IV		Aug NQC	Solar

Attachment A - List of physical resources by PTO, local area and market ID

SDG&E	CSLR4S_2_SOLAR	23299	DW GEN1 G2	0.315	26.65	G2	SD-IV		Aug NQC	Solar
SDG&E	ELCAJN_6_EB1BT1	22208	EL CAJON	69	7.50	1	SD-IV	San Diego, El Cajon		Battery
SDG&E	ELCAJN_6_LM6K	23320	EC GEN2	13.8	48.10	1	SD-IV	San Diego, El Cajon		Market
SDG&E	ELCAJN_6_UNITA1	22150	EC GEN1	13.8	45.42	1	SD-IV	San Diego, El Cajon		Market
SDG&E	ENERSJ_2_WIND	23100	ECO GEN1 G1	0.69	41.10	G1	SD-IV		Aug NQC	Wind
SDG&E	ESCND0_6_EB1BT1	22256	ESCNDIDO	69	10.00	1	SD-IV	San Diego, Esco		Battery
SDG&E	ESCND0_6_EB2BT2	22256	ESCNDIDO	69	10.00	1	SD-IV	San Diego, Esco		Battery
SDG&E	ESCND0_6_EB3BT3	22256	ESCNDIDO	69	10.00	1	SD-IV	San Diego, Esco		Battery
SDG&E	ESCND0_6_PL1X2	22257	ESGEN	13.8	48.71	1	SD-IV	San Diego, Esco		Market
SDG&E	ESCND0_6_UNITB1	22153	CALPK_ES	13.8	48.00	1	SD-IV	San Diego, Esco		Market
SDG&E	ESCO_6_GLMQF	22332	GOALLINE	69	36.41	1	SD-IV	San Diego, Esco	Aug NQC	Net Seller
SDG&E	IVSLRP_2_SOLAR1	23440	DW GEN2 G1	0.36	82.00	1	SD-IV		Aug NQC	Solar
SDG&E	IWEST_2_SOLAR1	23155	DU GEN1 G1	0.2	33.27	G1	SD-IV		Aug NQC	Solar
SDG&E	IWEST_2_SOLAR1	23156	DU GEN1 G2	0.2	28.23	G2	SD-IV		Aug NQC	Solar
SDG&E	JACMSR_1_JACSR1	23352	ECO GEN2	0.55	8.20	1	SD-IV		Aug NQC	Solar
SDG&E	LAKHDG_6_UNIT 1	22625	LKHODG1	13.8	20.00	1	SD-IV	San Diego, Esco		Market
SDG&E	LAKHDG_6_UNIT 2	22626	LKHODG2	13.8	20.00	2	SD-IV	San Diego, Esco		Market
SDG&E	LARKSP_6_UNIT 1	22074	LRKSPBD1	13.8	46.00	1	SD-IV	San Diego, Border		Market
SDG&E	LARKSP_6_UNIT 2	22075	LRKSPBD2	13.8	46.00	1	SD-IV	San Diego, Border		Market
SDG&E	LAROA1_2_UNITA1	20187	LRP-U1	16	0.00	1	SD-IV		Connect to CENACE/CF E grid for the summer – not available for ISO BAA RA purpose	Market
SDG&E	LAROA2_2_UNITA1	22996	INTBST	18	145.19	1	SD-IV			Market
SDG&E	LAROA2_2_UNITA1	22997	INTBCT	16	176.81	1	SD-IV			Market
SDG&E	LILIAC_6_SOLAR	22404	LILIAC	69	1.23	DG	SD-IV	San Diego		Solar
SDG&E	MRGT_6_MEF2	22487	MEF_MR2	13.8	44.00	1	SD-IV	San Diego		Market
SDG&E	MRGT_6_MMAREF	22486	MEF_MR1	13.8	45.00	1	SD-IV	San Diego		Market
SDG&E	MSHGTS_6_MMARLF	22448	MESAHGTS	69	4.37	1	SD-IV	San Diego, Mission	Aug NQC	Market

Attachment A - List of physical resources by PTO, local area and market ID

SDG&E	MSSION_2_QF	22496	MISSION	69	0.65	1	SD-IV	San Diego	Aug NQC	Market
SDG&E	MURRAY_6_UNIT	22532	MURRAY	69	0.00		SD-IV	San Diego	Not modeled Energy Only	Market
SDG&E	OCTILO_5_WIND	23314	OCO GEN G1	0.69	35.12	G1	SD-IV		Aug NQC	Wind
SDG&E	OCTILO_5_WIND	23318	OCO GEN G2	0.69	35.12	G2	SD-IV		Aug NQC	Wind
SDG&E	OGROVE_6_PL1X2	22628	PA GEN1	13.8	48.00	1	SD-IV	San Diego, Pala Inner, Pala Outer		Market
SDG&E	OGROVE_6_PL1X2	22629	PA GEN2	13.8	48.00	1	SD-IV	San Diego, Pala Inner, Pala Outer		Market
SDG&E	OTAY_6_LNDFL5	22604	OTAY	69	0.00		SD-IV	San Diego, Border	Not modeled Energy Only	Market
SDG&E	OTAY_6_LNDFL6	22604	OTAY	69	0.00		SD-IV	San Diego, Border	Not modeled Energy Only	Market
SDG&E	OTAY_6_PL1X2	22617	OYGEN	13.8	35.50	1	SD-IV	San Diego, Border		Market
SDG&E	OTAY_6_UNITB1	22604	OTAY	69	2.03	1	SD-IV	San Diego, Border	Aug NQC	Market
SDG&E	OTMESA_2_PL1X3	22605	OTAYMGT1	18	165.16	1	SD-IV	San Diego		Market
SDG&E	OTMESA_2_PL1X3	22606	OTAYMGT2	18	166.17	1	SD-IV	San Diego		Market
SDG&E	OTMESA_2_PL1X3	22607	OTAYMST1	16	272.27	1	SD-IV	San Diego		Market
SDG&E	PALOMR_2_PL1X3	22262	PEN_CT1	18	170.18	1	SD-IV	San Diego		Market
SDG&E	PALOMR_2_PL1X3	22263	PEN_CT2	18	170.18	1	SD-IV	San Diego		Market
SDG&E	PALOMR_2_PL1X3	22265	PEN_ST	18	225.24	1	SD-IV	San Diego		Market
SDG&E	PIOPIC_2_CTG1	23162	PIO PICO CT1	13.8	106.00	1	SD-IV	San Diego	No NQC - Pmax	Market
SDG&E	PIOPIC_2_CTG2	23163	PIO PICO CT2	13.8	106.00	1	SD-IV	San Diego	No NQC - Pmax	Market
SDG&E	PIOPIC_2_CTG3	23164	PIO PICO CT3	13.8	106.00	1	SD-IV	San Diego	No NQC - Pmax	Market
SDG&E	PTLOMA_6_NTCCGN	22660	POINTLMA	69	2.23	2	SD-IV	San Diego	Aug NQC	QF/Selfgen
SDG&E	SAMPSN_6_KELCO1	22704	SAMPSON	12.5	3.06	1	SD-IV	San Diego	Aug NQC	Net Seller
SDG&E	SMRCOS_6_LNDFIL	22724	SANMRCOS	69	1.50	1	SD-IV	San Diego	Aug NQC	Market
SDG&E	TERMEX_2_PL1X3	22982	TDM CTG2	18	156.44	1	SD-IV			Market
SDG&E	TERMEX_2_PL1X3	22983	TDM CTG3	18	156.44	1	SD-IV			Market
SDG&E	TERMEX_2_PL1X3	22981	TDM STG	21	280.13	1	SD-IV			Market
SDG&E	VLCNTR_6_VCSLR	22870	VALCNTR	69	0.96	DG	SD-IV	San Diego, Esco	Aug NQC	Solar
SDG&E	VLCNTR_6_VCSLR1	22870	VALCNTR	69	1.03	DG	SD-IV	San Diego, Esco	Aug NQC	Solar
SDG&E	VLCNTR_6_VCSLR2	22870	VALCNTR	69	2.05	DG	SD-IV	San Diego, Esco	Aug NQC	Solar

Attachment A - List of physical resources by PTO, local area and market ID

SDG&E	VSTAES_6_VESBT1	23541	Q1061_BESS	0.48	5.50	1	SD-IV	San Diego, Pala Outer	No NQC - est. data	Battery
SDG&E	VSTAES_6_VESBT1	23216	Q1294_BESS	0.48	5.50	C9	SD-IV	San Diego, Pala Outer	No NQC - est. data	Battery
SDG&E	WISTRA_2_WRSSR1	23287	Q429_G1	0.31	41.00	1	SD-IV		Aug NQC	Solar
SDG&E	ZZ_NA	22916	PFC-AVC	0.6	0.00	1	SD-IV	San Diego	No NQC - hist. data	QF/Selfgen
SDG&E	ZZZ_New Unit	23597	Q1175_BESS	0.48	0.00	1	SD-IV		Energy Only	Battery
SDG&E	ZZZ_New Unit	23441	DW GEN2 G2	0.42	61.60	1	SD-IV		Aug NQC	Solar
SDG&E	ZZZ_New Unit	23710	Q1170_BESS	0.48	62.50	1	SD-IV	San Diego	No NQC - Pmax	Battery
SDG&E	ZZZ_New Unit	22942	BUE GEN 1_G1	0.69	11.60	G1	SD-IV		No NQC - est. data	Wind
SDG&E	ZZZ_New Unit	22945	BUE GEN 1_G2	0.69	11.60	G2	SD-IV		No NQC - est. data	Wind
SDG&E	ZZZ_New Unit	22947	BUE GEN 1_G3	0.69	11.60	G3	SD-IV		No NQC - est. data	Wind
SDG&E	ZZZ_New Unit	22949	BUE GEN 1_G4	0.69	26.00	G3	SD-IV		No NQC - est. data	Wind
SDG&E	ZZZ_New Unit	22020	AVOCADO	69	2.00	S2	SD-IV	San Diego, Pala Inner, Pala Outer	No NQC - Pmax	Battery
SDG&E	ZZZZ_New Unit	23234	Q1429	0.48	0.00	1	SD-IV		No NQC - est. data	Wind
SDG&E	ZZZZ_New Unit	23412	Q1434_G	0.64	30.00	1	SD-IV	San Diego	No NQC - Pmax	Battery
SDG&E	ZZZZ_New Unit	23443	DW GEN2 G3B	0.6	35.10	1	SD-IV		Aug NQC	Solar
SDG&E	ZZZZ_New Unit	23442	DW GEN2 G3A	0.6	49.20	1	SD-IV		Aug NQC	Solar
SDG&E	ZZZZ_New Unit	23544	Q1169_BESS 1	0.4	35.00	C8	SD-IV	San Diego, Pala Inner, Pala Outer	No NQC - Pmax	Battery
SDG&E	ZZZZ_New Unit	23519	Q1169_BESS 2	0.4	35.00	C8	SD-IV	San Diego, Pala Inner, Pala Outer	No NQC - Pmax	Battery
SDG&E	ZZZZ_New Unit	23131	Q183_G1	0.69	0.00	G1	SD-IV		Energy Only	Wind
SDG&E	ZZZZ_New Unit	23134	Q183_G2	0.69	0.00	G2	SD-IV		Energy Only	Wind
SDG&E	ZZZZ_New Unit	23100	ECOGEN1	0.48	41.00	G2	SD-IV		No NQC - est. data	Wind
SDG&E	ZZZZ_CBRILLO_6_PLSTP 1	22092	CABRILLO	69	0.00	1	SD-IV	San Diego	Aug NQC	Market

Attachment A - List of physical resources by PTO, local area and market ID

SDG&E	ZZZZ_DIVSON_6_NSQF	22172	DIVISION	69	0.00	1	SD-IV	San Diego	Retired	QF/Selfgen
SDG&E	ZZZZ_ELCAJN_7_GT1	22212	ELCAJNGT	12.5	0.00	1	SD-IV	San Diego, El Cajon	Retired	Market
SDG&E	ZZZZ_ENCINA_7_EA1	22233	ENCINA 1	14.4	0.00	1	SD-IV	San Diego, Encina	Retired	Market
SDG&E	ZZZZ_ENCINA_7_EA2	22234	ENCINA 2	14.4	0.00	1	SD-IV	San Diego, Encina	Retired by 2019	Market
SDG&E	ZZZZ_ENCINA_7_EA3	22236	ENCINA 3	14.4	0.00	1	SD-IV	San Diego, Encina	Retired by 2019	Market
SDG&E	ZZZZ_ENCINA_7_EA4	22240	ENCINA 4	22	0.00	1	SD-IV	San Diego, Encina	Retired by 2019	Market
SDG&E	ZZZZ_ENCINA_7_EA5	22244	ENCINA 5	24	0.00	1	SD-IV	San Diego, Encina	Retired by 2019	Market
SDG&E	ZZZZ_ENCINA_7_GT1	22248	ENCINAGT	12.5	0.00	1	SD-IV	San Diego, Encina	Retired by 2019	Market
SDG&E	ZZZZ_KEARNY_7_KY2	22373	KEARN2AB	12.5	0.00	1	SD-IV	San Diego, Mission	Retired	Market
SDG&E	ZZZZ_KEARNY_7_KY2	22374	KEARN2CD	12.5	0.00	1	SD-IV	San Diego, Mission	Retired	Market
SDG&E	ZZZZ_KEARNY_7_KY2	22373	KEARN2AB	12.5	0.00	2	SD-IV	San Diego, Mission	Retired	Market
SDG&E	ZZZZ_KEARNY_7_KY2	22374	KEARN2CD	12.5	0.00	2	SD-IV	San Diego, Mission	Retired	Market
SDG&E	ZZZZ_KEARNY_7_KY3	22375	KEARN3AB	12.5	0.00	1	SD-IV	San Diego, Mission	Retired	Market
SDG&E	ZZZZ_KEARNY_7_KY3	22376	KEARN3CD	12.5	0.00	1	SD-IV	San Diego, Mission	Retired	Market
SDG&E	ZZZZ_KEARNY_7_KY3	22375	KEARN3AB	12.5	0.00	2	SD-IV	San Diego, Mission	Retired	Market
SDG&E	ZZZZ_KEARNY_7_KY3	22376	KEARN3CD	12.5	0.00	2	SD-IV	San Diego, Mission	Retired	Market
SDG&E	ZZZZ_MRGT_7_UNITS	22488	MIRAMRGT	12.5	0.00	1	SD-IV	San Diego	Retired	Market
SDG&E	ZZZZ_MRGT_7_UNITS	22488	MIRAMRGT	12.5	0.00	2	SD-IV	San Diego	Retired	Market
SDG&E	ZZZZ_NIMTG_6_NIQF	22576	NOISLMTR	69	0.00	1	SD-IV	San Diego	Retired	QF/Selfgen
SDG&E	ZZZZ_OTAY_7_UNITC1	22604	OTAY	69	0.00	3	SD-IV	San Diego, Border	Aug NQC	QF/Selfgen
SDG&E	ZZZZ_PTLOMA_6_NTCQ F	22660	POINTLMA	69	0.00	1	SD-IV	San Diego	Retired	QF/Selfgen

o

Attachment B – Effectiveness factors for procurement guidance

Table - Eagle Rock.

Effectiveness factors to the Eagle Rock-Cortina 115 kV line:

Gen Bus	Gen Name	Gen ID	Eff Factor (%)
31406	GEYSR5-6	1	36
31406	GEYSR5-6	2	36
31408	GEYSER78	1	36
31408	GEYSER78	2	36
31412	GEYSER11	1	37
31435	GEO.ENGY	1	35
31435	GEO.ENGY	2	35
31433	POTTRVLY	1	34
31433	POTTRVLY	3	34
31433	POTTRVLY	4	34
38020	CITY UKH	1	32
38020	CITY UKH	2	32

Table - Fulton

Effectiveness factors to the Lakeville-Petaluma-Cotati 60 kV line:

Gen Bus	Gen Name	Gen ID	Eff Factor (%)
31466	SONMA LF	1	52
31422	GEYSER17	1	12
31404	WEST FOR	1	12
31404	WEST FOR	2	12
31414	GEYSER12	1	12
31418	GEYSER14	1	12
31420	GEYSER16	1	12
31402	BEAR CAN	1	12
31402	BEAR CAN	2	12

Attachment B - Effectiveness factors for procurement guidance

Gen Bus	Gen Name	Gen ID	Eff Factor (%)
38110	NCPA2GY1	1	12
38112	NCPA2GY2	1	12
32700	MONTICLO	1	10
32700	MONTICLO	2	10
32700	MONTICLO	3	10
31435	GEO.ENGY	1	6
31435	GEO.ENGY	2	6
31408	GEYSER78	1	6
31408	GEYSER78	2	6
31412	GEYSER11	1	6
31406	GEYSR5-6	1	6
31406	GEYSR5-6	2	6

Table - Lakeville

Effectiveness factors to the Vaca Dixon-Lakeville 230 kV line:

Gen Bus	Gen Name	Gen ID	Eff Fctr (%)
31400	SANTA FE	2	38
31430	SMUDGE01	1	38
31400	SANTA FE	1	38
31416	GEYSER13	1	38
31424	GEYSER18	1	38
31426	GEYSER20	1	38
38106	NCPA1GY1	1	38
38108	NCPA1GY2	1	38
31421	BOTTLERK	1	36
31404	WEST FOR	2	36
31402	BEAR CAN	1	36
31402	BEAR CAN	2	36
31404	WEST FOR	1	36
31414	GEYSER12	1	36
31418	GEYSER14	1	36
31420	GEYSER16	1	36

Attachment B - Effectiveness factors for procurement guidance

Gen Bus	Gen Name	Gen ID	Eff Fctr (%)
31422	GEYSER17	1	36
38110	NCPA2GY1	1	36
38112	NCPA2GY2	1	36
31446	SONMA LF	1	36
32700	MONTICLO	1	31
32700	MONTICLO	2	31
32700	MONTICLO	3	31
31406	GEYSR5-6	1	18
31406	GEYSR5-6	2	18
31405	RPSP1014	1	18
31408	GEYSER78	1	18
31408	GEYSER78	2	18
31412	GEYSER11	1	18
31435	GEO.ENGY	1	18
31435	GEO.ENGY	2	18
31433	POTTRVLY	1	15
31433	POTTRVLY	2	15
31433	POTTRVLY	3	15
38020	CITY UKH	1	15
38020	CITY UKH	2	15

Table – Rio Oso

Effectiveness factors to the Rio Oso-Atlantic 230 kV line:

Gen Bus	Gen Name	Gen ID	Eff Fctr. (%)
32498	SPILINCF	1	49
32500	ULTR RCK	1	49
32456	MIDLFORK	1	33
32456	MIDLFORK	2	33
32458	RALSTON	1	33

Attachment B - Effectiveness factors for procurement guidance

32513	ELDRADO1	1	32
32514	ELDRADO2	1	32
32510	CHILIBAR	1	32
32486	HELLHOLE	1	31
32508	FRNCH MD	1	30
32460	NEWCSTLE	1	26
32478	HALSEY F	1	24
32512	WISE	1	24
38114	Stig CC	1	14
38123	Q267CT	1	14
38124	Q267ST	1	14
32462	CHI.PARK	1	8
32464	DTCHFLT1	1	4

Table – Sierra Overall

Effectiveness factors to the Table Mountain – Pease 60 kV line:

Gen Bus	Gen Name	Gen ID	Eff Fctr. (%)
32492	GRNLEAF2	1	17
32494	YUBA CTY	1	17
32496	YCEC	1	17
31794	WOODLEAF	1	6
31814	FORBSTWN	1	6
31832	SLY.CR.	1	6
31834	KELLYRDG	1	6
31888	OROVLENRG	1	6

Attachment B - Effectiveness factors for procurement guidance

Gen Bus	Gen Name	Gen ID	Eff Fctr. (%)
32451	FREC	1	5
32450	COLGATE1	1	5
32466	NARROWS1	1	5
32468	NARROWS2	1	5
32470	CMP.FARW	1	5
32452	COLGATE2	1	5
32156	WOODLAND	1	4
32498	SPILINCF	1	4
32502	DTCHFLT2	1	4
32454	DRUM 5	1	3
32474	DEER CRK	1	3
32476	ROLLINSF	1	3
32484	OXBOW F	1	3
32504	DRUM 1-2	1	3
32504	DRUM 1-2	2	3
32506	DRUM 3-4	1	3
32506	DRUM 3-4	2	3
32464	DTCHFLT1	1	3
32480	BOWMAN	1	3
32488	HAYPRES+	1	3
32488	HAYPRES+	2	3
32472	SPAULDG	1	3
32472	SPAULDG	2	3
32472	SPAULDG	3	3

Attachment B - Effectiveness factors for procurement guidance

Gen Bus	Gen Name	Gen ID	Eff Fctr. (%)
32462	CHI.PARK	1	3
32500	ULTR RCK	1	3
31784	BELDEN	1	3
31786	ROCK CK1	1	3
31788	ROCK CK2	1	3
31790	POE 1	1	3
31792	POE 2	1	3
31812	CRESTA	1	3
31812	CRESTA	2	3
31820	BCKS CRK	1	3
31820	BCKS CRK	2	3
32478	HALSEY F	1	2
32512	WISE	1	2
32460	NEWCASTLE	1	2
32510	CHILIBAR	1	2
32513	ELDRADO1	1	2
32514	ELDRADO2	1	2
32456	MIDLFORK	1	2
32456	MIDLFORK	2	2
32458	RALSTON	1	2
32486	HELLHOLE	1	2
32508	FRNCH MD	1	2
38114	STIG CC	1	1
38123	LODI CT1	1	1

Attachment B - Effectiveness factors for procurement guidance

Gen Bus	Gen Name	Gen ID	Eff Fctr. (%)
38124	LODI ST1	1	1

Table – San Jose

Effectiveness factors to the El Patio-San Jose 'A' 115 kV line:

Gen Bus	Gen Name	Gen ID	Eff Fctr (%)
35863	CATALYST	1	36
36863	DVRaGT1	1	13
36864	DVRbGt2	1	13
36865	DVRaST3	1	13
36859	Laf300	2	13
36859	Laf300	1	13
36856	CCA100	1	13
36858	Gia100	1	12
36895	Gia200	1	12
35861	SJ-SCL W	1	9
35854	LECEFGT1	1	9
35855	LECEFGT2	1	9
35856	LECEFGT3	1	9
35857	LECEFGT4	1	9
35858	LECEFST1	1	9
35860	OLS-AGNE	1	9

Table – South Bay-Moss Landing

Effectiveness factors to the Moss Landing-Las Aguillas 230 kV line:

Gen Bus	Gen Name	Gen ID	Eff Fctr. (%)
36209	SLD ENRG	1	20
36221	DUKMOSS1	1	20
36222	DUKMOSS2	1	20

Attachment B - Effectiveness factors for procurement guidance

36223	DUKMOSS3	1	20
36224	DUKMOSS4	1	20
36225	DUKMOSS5	1	20
36226	DUKMOSS6	1	20
36405	MOSSLND6	1	17
36406	MOSSLND7	1	17
35881	MEC CTG1	1	13
35882	MEC CTG2	1	13
35883	MEC STG1	1	13
35850	GLRY COG	1	12
35850	GLRY COG	2	12
35851	GROYPKR1	1	12
35852	GROYPKR2	1	12
35853	GROYPKR3	1	12
35623	SWIFT	BT	10
35863	CATALYST	1	10
36863	DVRaGT1	1	8
36864	DVRbGt2	1	8
36865	DVRaST3	1	8
36859	Laf300	2	8
36859	Laf300	1	8
36858	Gia100	1	7
36895	Gia200	1	7
35854	LECEFGT1	1	7
35855	LECEFGT2	1	7

Attachment B - Effectiveness factors for procurement guidance

35856	LECEFGT3	1	7
35857	LECEFGT4	1	7
35858	LECEFST1	1	7
35860	OLS-AGNE	1	7

Table – Ames/Pittsburg/Oakland

Effectiveness factors to the Ames-Ravenswood #1 115 kV line:

Gen Bus	Gen Name	Gen ID	Eff Fctr. (%)
35304	RUSELCT1	1	10
35305	RUSELCT2	2	10
35306	RUSELST1	3	10
33469	OX_MTN	1	10
33469	OX_MTN	2	10
33469	OX_MTN	3	10
33469	OX_MTN	4	10
33469	OX_MTN	5	10
33469	OX_MTN	6	10
33469	OX_MTN	7	10
33107	DEC STG1	1	3
33108	DEC CTG1	1	3
33109	DEC CTG2	1	3
33110	DEC CTG3	1	3
33102	COLUMBIA	1	3
33111	LMECCT2	1	3
33112	LMECCT1	1	3

Attachment B - Effectiveness factors for procurement guidance

33113	LMECST1	1	3
33151	FOSTER W	1	2
33151	FOSTER W	2	2
33151	FOSTER W	3	2
33136	CCCSD	1	2
33141	SHELL 1	1	2
33142	SHELL 2	1	2
33143	SHELL 3	1	2
32900	CRCKTCOG	1	2
32910	UNOCAL	1	2
32910	UNOCAL	2	2
32910	UNOCAL	3	2
32920	UNION CH	1	2
32921	ChevGen1	1	2
32922	ChevGen2	1	2
32923	ChevGen3	3	2
32741	HILLSIDE_12	1	2
32901	OAKLND 1	1	1
32902	OAKLND 2	2	1
32903	OAKLND 3	3	1
38118	ALMDACT1	1	1
38119	ALMDACT2	1	1

Effectiveness factors to the Moraga-Clairemont #2 115 kV line:

Gen Bus	Gen Name	Gen ID	Eff Fctr. (%)
---------	----------	--------	---------------

Attachment B - Effectiveness factors for procurement guidance

32741	HILLSIDE_12	1	15
32921	ChevGen1	1	15
32922	ChevGen2	1	15
32923	ChevGen3	3	15
32920	UNION CH	1	14
32910	UNOCAL	1	13
32910	UNOCAL	2	13
32910	UNOCAL	3	13
32901	OAKLND 1	1	10
32902	OAKLND 2	2	10
32903	OAKLND 3	3	10
38118	ALMDACT1	1	10
38119	ALMDACT2	1	10
33141	SHELL 1	1	9
33142	SHELL 2	1	9
33143	SHELL 3	1	9
33136	CCCSD	1	8
32900	CRCKTCOG	1	7
33151	FOSTER W	1	6
33151	FOSTER W	2	6
33151	FOSTER W	3	6
33102	COLUMBIA	1	3
33111	LMECCT2	1	3
33112	LMECCT1	1	3
33113	LMECST1	1	3

Attachment B - Effectiveness factors for procurement guidance

33107	DEC STG1	1	3
33108	DEC CTG1	1	3
33109	DEC CTG2	1	3
33110	DEC CTG3	1	3

Table – Herndon

Effectiveness factors to the Herndon-Manchester 115 kV line:

Gen Bus	Gen Name	Gen ID	Eff Fctr. (%)
34624	BALCH 1	1	22
34616	KINGSRIV	1	21
34500	DINUBA	TA	19
34648	DINUBA E	1	19
34671	KRCDPCT1	1	19
34672	KRCDPCT2	1	19
34308	KERCKHOF	1	17
34344	KERCK1-1	1	17
34345	KERCK1-3	3	17
34690	CORCORAN_3	FW	15
34692	CORCORAN_4	FW	15
34677	Q558	1	15
34696	CORCORANPV_S	1	15
34610	HAAS	1	13
34610	HAAS	2	13
34612	BLCH 2-2	1	13
34614	BLCH 2-3	1	13

Attachment B - Effectiveness factors for procurement guidance

34431	GWF_HEP1	1	8
34433	GWF_HEP2	1	8
34617	Q581	1	5
34680	KANSAS	1	5
34467	GIFFEN_DIST	1	4
34563	STROUD_DIST	2	4
34563	STROUD_DIST	1	4
34608	AGRICO	2	4
34608	AGRICO	3	4
34608	AGRICO	4	4
34644	Q679	1	4
365502	Q632BC1	1	4

Table – LA Basin

Effectiveness factors to the Mesa – Laguna Bell #1 230 kV line:

Gen Bus	Gen Name	Gen ID	Eff Fctr. (%)
29951	REFUSE	D1	35
24239	MALBRG1G	C1	34
24240	MALBRG1G	C2	34
24241	MALBRG1G	S3	34
29903	ELSEG6ST	6	27
29904	ELSEG5GT	5	27
29902	ELSEG7ST	7	27
29901	ELSEG8GT	8	27
24337	VENICE	1	26

Attachment B - Effectiveness factors for procurement guidance

24094	MOBGEN1	1	26
24329	MOBGEN2	1	26
24332	PALOGEN	D1	26
24011	ARCO 1G	1	23
24012	ARCO 2G	2	23
24013	ARCO 3G	3	23
24014	ARCO 4G	4	23
24163	ARCO 5G	5	23
24164	ARCO 6G	6	23
24062	HARBOR G	1	23
24062	HARBOR G	HP	23
25510	HARBORG4	LP	23
24327	THUMSGEN	1	23
24020	CARBGEN1	1	23
24328	CARBGEN2	1	23
24139	SERRFGEN	D1	23
24070	ICEGEN	1	22
24001	ALAMT1 G	1	18
24002	ALAMT2 G	2	18
24003	ALAMT3 G	3	18
24004	ALAMT4 G	4	18
24005	ALAMT5 G	5	18
24161	ALAMT6 G	6	18
90000	ALMT-GT1	X1	18
90001	ALMT-GT2	X2	18

Attachment B - Effectiveness factors for procurement guidance

90002	ALMT-ST1	X3	18
29308	CTRPKGEN	1	18
29953	SIGGEN	D1	18
29309	BARPKGEN	1	13
29201	WALCRKG1	1	12
29202	WALCRKG2	1	12
29203	WALCRKG3	1	12
29204	WALCRKG4	1	12
29205	WALCRKG5	1	12
29011	BREAPWR2	C1	12
29011	BREAPWR2	C2	12
29011	BREAPWR2	C3	12
29011	BREAPWR2	C4	12
29011	BREAPWR2	S1	12
24325	ORCOGEN	I	12
24341	COYGEN	I	11
25192	WDT1406_G	I	11
25208	DowlingCTG	1	10
25211	CanyonGT 1	1	10
25212	CanyonGT 2	2	10
25213	CanyonGT 3	3	10
25214	CanyonGT 4	4	10
24216	VILLA PK	DG	9

Table – Rector

Attachment B - Effectiveness factors for procurement guidance

Effectiveness factors to the Rector-Vestal 230 kV line:

Gen Bus	Gen Name	Gen ID	MW Eff Fctr (%)
24370	KAWGEN	1	51
24306	B CRK1-1	1	45
24306	B CRK1-1	2	45
24307	B CRK1-2	3	45
24307	B CRK1-2	4	45
24319	EASTWOOD	1	45
24323	PORTAL	1	45
24308	B CRK2-1	1	45
24308	B CRK2-1	2	45
24309	B CRK2-2	3	45
24309	B CRK2-2	4	45
24310	B CRK2-3	5	45
24310	B CRK2-3	6	45
24315	B CRK 8	81	45
24315	B CRK 8	82	45
24311	B CRK3-1	1	45
24311	B CRK3-1	2	45
24312	B CRK3-2	3	45
24312	B CRK3-2	4	45
24313	B CRK3-3	5	45
24317	MAMOTH1G	1	45
24318	MAMOTH2G	2	45
24314	B CRK 4	41	43
24314	B CRK 4	42	43

Table – San Diego

Attachment B - Effectiveness factors for procurement guidance

Effectiveness factors to the Imperial Valley – El Centro 230 kV line (i.e., the “S” line):

Gen Bus	Gen Name	Gen ID	Eff Fctr. (%)
22982	TDM CTG2	1	25
22983	TDM CTG3	1	25
22981	TDM STG	1	25
22997	INTBCT	1	25
22996	INTBST	1	25
23440	DW GEN2 G1	1	25
23298	DW GEN1 G1	G1	25
23156	DU GEN1 G2	G2	25
23299	DW GEN1 G2	G2	25
23155	DU GEN1 G1	G1	25
23441	DW GEN2 G2	1	25
23442	DW GEN2 G3A	1	25
23443	DW GEN2 G3B	1	25
23314	OCO GEN G1	G1	23
23318	OCO GEN G2	G2	23
23100	ECO GEN1 G	G1	22
23352	ECO GEN2 G	1	21
22605	OTAYMGT1	1	18
22606	OTAYMGT2	1	18
22607	OTAYMST1	1	18
23162	PIO PICO CT1	1	18
23163	PIO PICO CT2	1	18
23164	PIO PICO CT3	1	18

Attachment B - Effectiveness factors for procurement guidance

22915	KUMEYAAY	1	17
23320	EC GEN2	1	17
22150	EC GEN1	1	17
22617	OY GEN	1	17
22604	OTAY	1	17
22604	OTAY	3	17
22172	DIVISION	1	17
22576	NOISLMTR	1	17
22704	SAMPSON	1	17
22092	CABRILLO	1	17
22074	LRKSPBD1	1	17
22075	LRKSPBD2	1	17
22660	POINTLMA	1	17
22660	POINTLMA	2	17
22149	CALPK_BD	1	17
22448	MESAHGTS	1	16
22120	CARLTNHS	1	16
22120	CARLTNHS	2	16
22496	MISSION	1	16
22486	MEF MR1	1	16
22124	CHCARITA	1	16
22487	MEF MR2	1	16
22625	LkHodG1	1	16
22626	LkHodG2	2	16
22332	GOALLINE	1	15

Attachment B - Effectiveness factors for procurement guidance

22262	PEN_CT1	1	15
22153	CALPK_ES	1	15
22786	EA GEN1 U6	1	15
22787	EA GEN1 U7	1	15
22783	EA GEN1 U8	1	15
22784	EA GEN1 U9	1	15
22789	EA GEN1 U10	1	15
22257	ES GEN	1	15
22263	PEN_CT2	1	15
22265	PEN_ST	1	15
22724	SANMRCOS	1	15
22628	PA GEN1	1	14
22629	PA GEN2	1	14
22082	BR GEN1	1	14
22112	CAPSTRNO	1	12