

## **Gates 500kV Dynamic Reactive Support Description and Functional Specifications for Competitive Solicitation**

## 1. Description

In the 2018-2019 Transmission Plan, the ISO has identified a reliability-driven need for a +/-800 MVAR dynamic reactive power support connecting to the Gates 500 kV bus as depicted below.

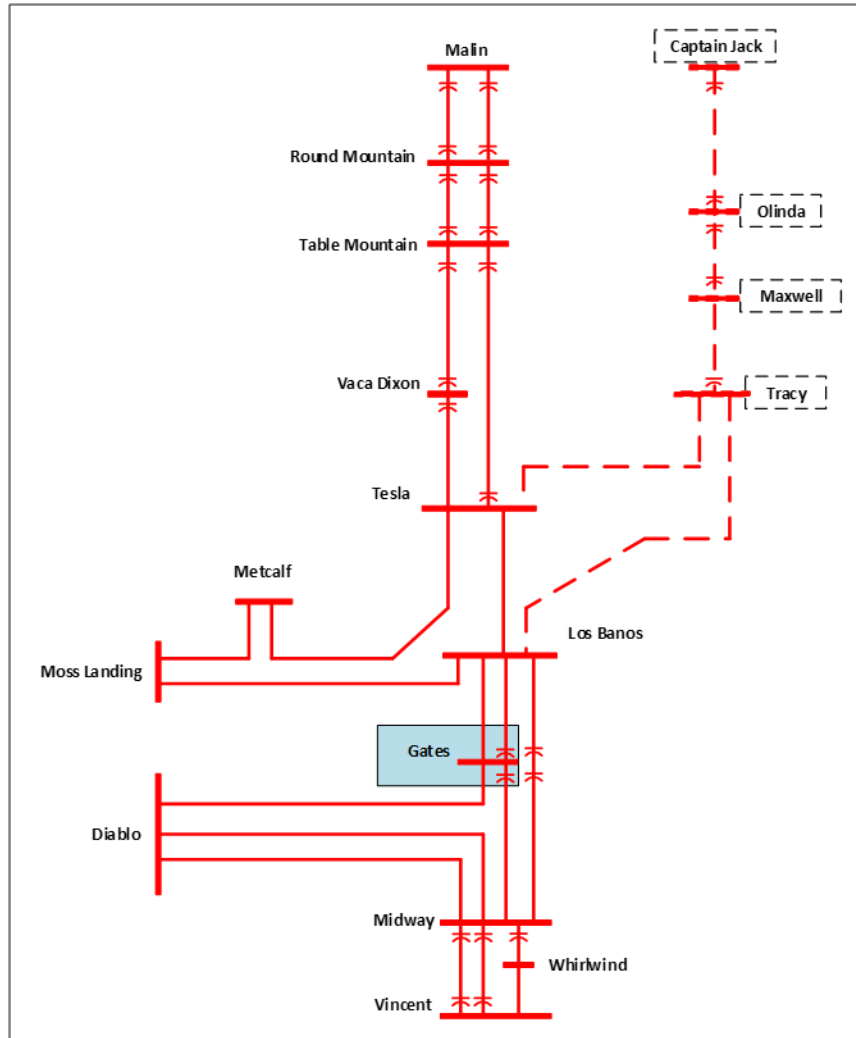

The reactive device is to be installed in a minimum of two equally-sized blocks independently connected to the 500 kV bus to accommodate maintenance and contingencies of the reactive device. These blocks are to be completely independent of each other and have their own dedicated connections to the bus. There will be no single point of failure between them. The blocks will not share a 500kV breaker and the associated step up transformers will be separated by a blast wall. However, both tie lines can be on the same tower.

The reactive power support is required to provide continuous dynamic reactive power output over the complete range of the capability (unless the facility experienced a planned or forced outage). It can be one of the following types of devices: SVC (Static VAR Compensator) with Thyristor Switched Capacitors (TSC), STATCOM (Static Synchronous Compensator), or

Synchronous Condenser. An appropriately sized and configured inverter associated with a battery storage project could also provide the reactive support. Voltage support requirements would take precedence over any other operation of the battery storage facility. Subsynchronous Resonance (SSR) studies are required to be completed and any identified mitigation shall be implemented as part of this project. The ISO estimates that the proposed reactive power support will approximately cost \$210 to \$250 million. The project is to be in-service by June of 2024. The figure below provides a schematic diagram of the current bus configuration in the Gates 500 kV switchyard with the previously approved transmission project and projects identified in the generation interconnection process to facilitate the interconnection of generator interconnection requests in the ISO queue. The project interconnections can enter the Gates substation from either the north or the south side.

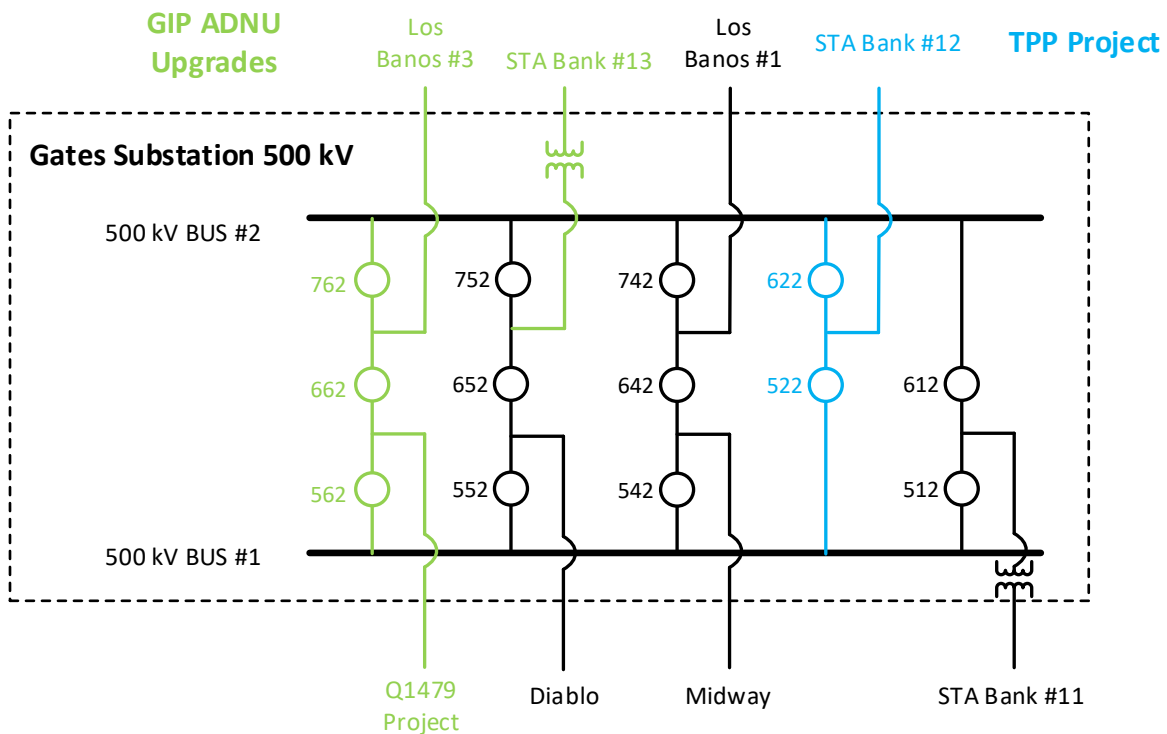

## 2. Functional Specifications

### Dynamic Reactive Power Support Functional Specification

Point of Interconnection: Gates 500 kV bus

Rated Real Power Output: 0 MW

Rated MVAR: +800/-800 MVAR at the Gates 500 kV bus. The entire inductive (absorption) range shall be continuously available when the voltage is in the 500 kV – 550 kV range and the entire capacitive (injection) range shall be available when the voltage is in the 473 kV – 540 kV range.

Response time: The time required for the output to go from 10% of the final value to 90% of the final value shall be less than 100 ms.

Nominal Terminal Voltage: 500 kV (typically the bus voltage is at 530 kV)

Latest in Service Date: June 1, 2024

Inverter Ride Through Capability: NERC PRC-024 requirements and NERC industry recommendation on momentary cessation<sup>1</sup>.

Availability and Reliability requirements: Proposed dynamic reactive power support solutions shall be designed for high availability. All proposals shall provide a calculation identifying the designed annual availability of the dynamic reactive support device proposed.

<sup>1</sup> [https://www.nerc.com/pa/rrm/bpsa/Alerts%20DL/NERC\\_Alert\\_Loss\\_of\\_Solar\\_Resources\\_during\\_Transmission\\_Disturbance-II\\_2018.pdf](https://www.nerc.com/pa/rrm/bpsa/Alerts%20DL/NERC_Alert_Loss_of_Solar_Resources_during_Transmission_Disturbance-II_2018.pdf)