



2021 & 2025 Draft LCR Study Results San Diego Non-Bulk Sub-Areas

Frank Chen

Regional Transmission Engineer Lead

Stakeholder Call

March 16, 2020

San Diego Non-Bulk LCR Area

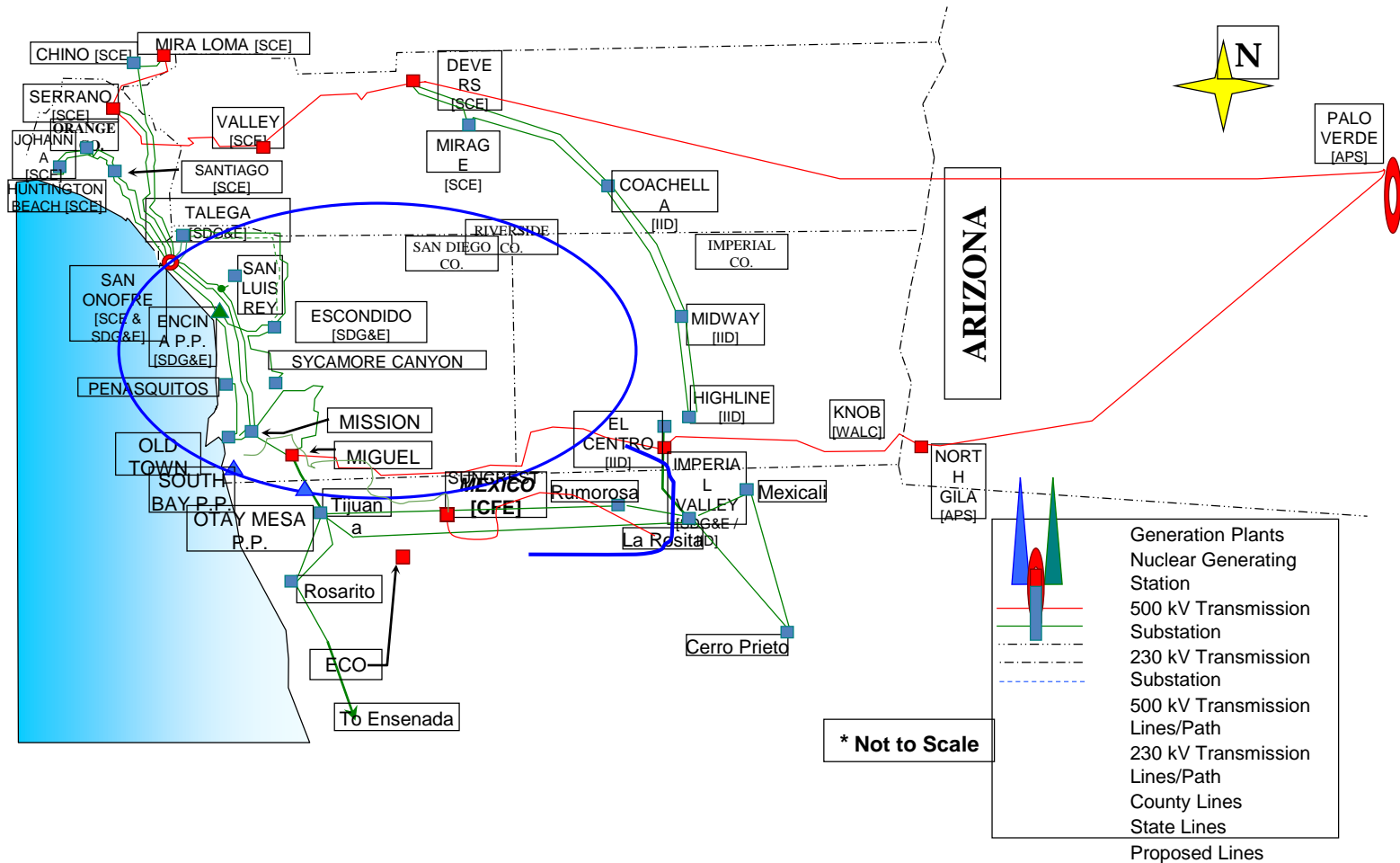

Major Network Upgrades Modeled by 2021

1. Ocean Ranch 69 kV substation
3. TL6906 Mesa Rim loop-in
4. Mesa Height TL600 Loop-in
4. TL633 Upgrade Bernardo - Rancho Carmel 69 kV line
5. Suncrest SVC project
6. 2nd Poway–Pomerado 69 kV line
7. Otay Landfill Gas Resources Retirement
8. Miramar Energy Storage Project (30 MW)
9. Storage projects at Melrose (40 MW)

Additional Network Upgrades by 2025

1. 2nd San Marcos–Escondido 69 kV line
2. Reconductor of Stuart Tap–Las Pulgas 69 kV line (TL690E)
3. Artesian 230 kV expansion with 69 kV upgrade
4. IID's S-Line Upgrade
5. South Orange County Reliability Enhancement
6. Avocado Energy Storage project (40 MW)

Sub-areas studied:

- Border sub-area
- El Cajon sub-area
- Esco sub-area
- Pala sub-area
- Mission sub-area
- Miramar sub-area

Sub-areas without LCR requirement in 2021 and 2025 due to the LCR criteria change or network upgrade

- Esco sub-area
- Pala sub-area
- Mission sub-area
- Miramar sub-area

Border Sub-area: Load and Resources

		2021	2025
Load (MW)	Gross Load	162	166
	AAEE	-8	-8
	Behind-The-Meter PV	0	0
	Net Load	154	158
	Transmission Loss	2	2
	Net Load + Loss	156	160
Resources (MW)	Gas-Fired	175.5	175.5
	Solar PV	0.0	0.0
	Wind	0.0	0.0
	QF/Other	0.0	0.0
	Demand Response	0.0	0.0
	Energy Storage	0.0	0.0

Border Sub-area: One-line diagram

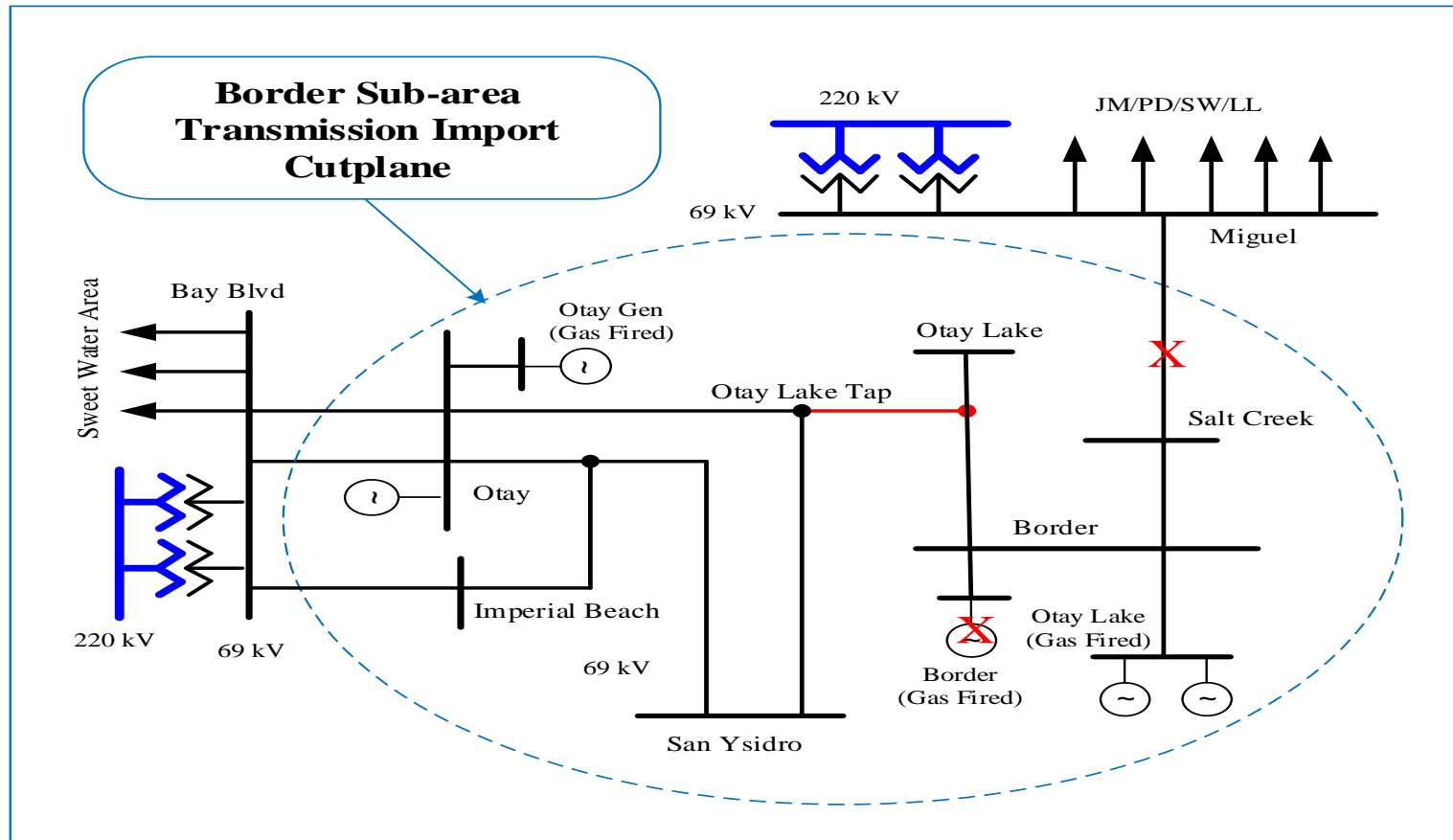

Border Sub-area: LCR Requirement

Year	Category	Contingency	Limiting Facility	LCR (MW)
2021	P3	Border unit out of service followed by the outage of Miguel-Salt Creek 69 kV #1 (TL6910)	Otay-Otay Lake Tap 69 kV (TL649)	60
2025	P3	Border unit out of service followed by the outage of Miguel-Salt Creek 69 kV #1 (TL6910)	Otay-Otay Lake Tap 69 kV (TL649)	62

Border Sub-area Load Profiles - 2021

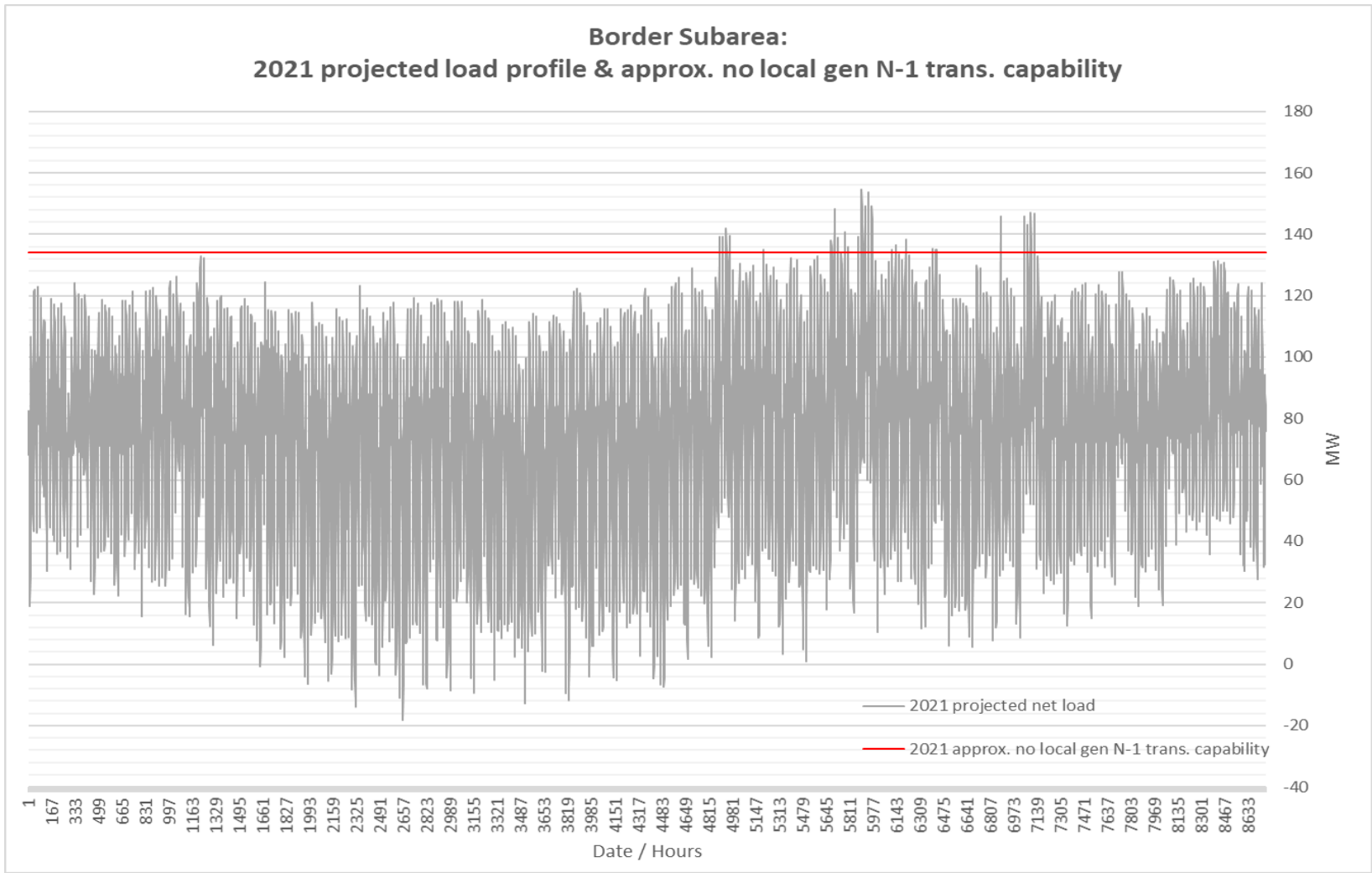

Border Sub-area Daily Load Profiles and L-1 Load Serving Capability - 2021

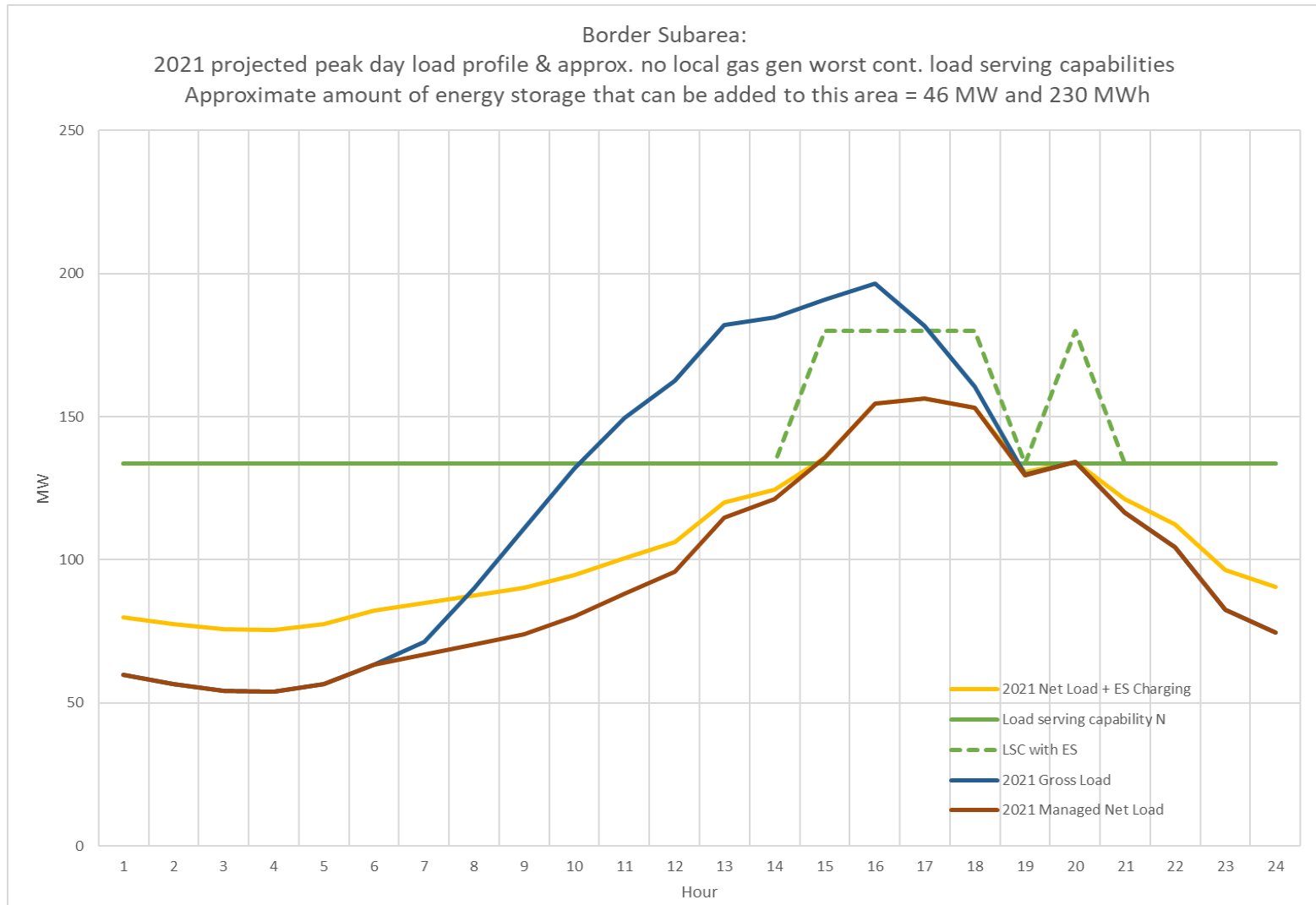

Border Sub-area Annual Load Profiles - 2025

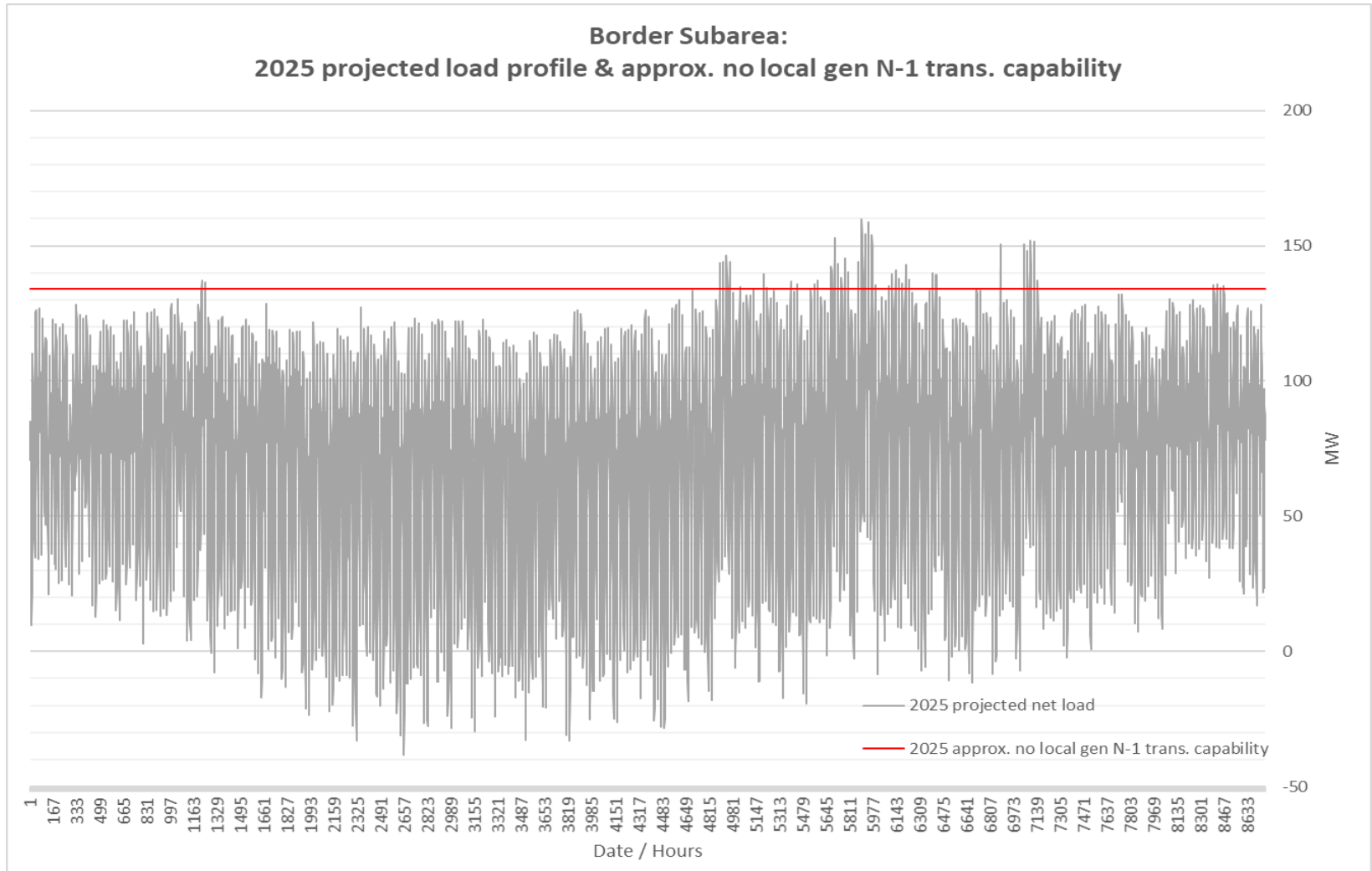

Border Sub-area Daily Load Profiles and L-1 Load Serving Capability - 2025

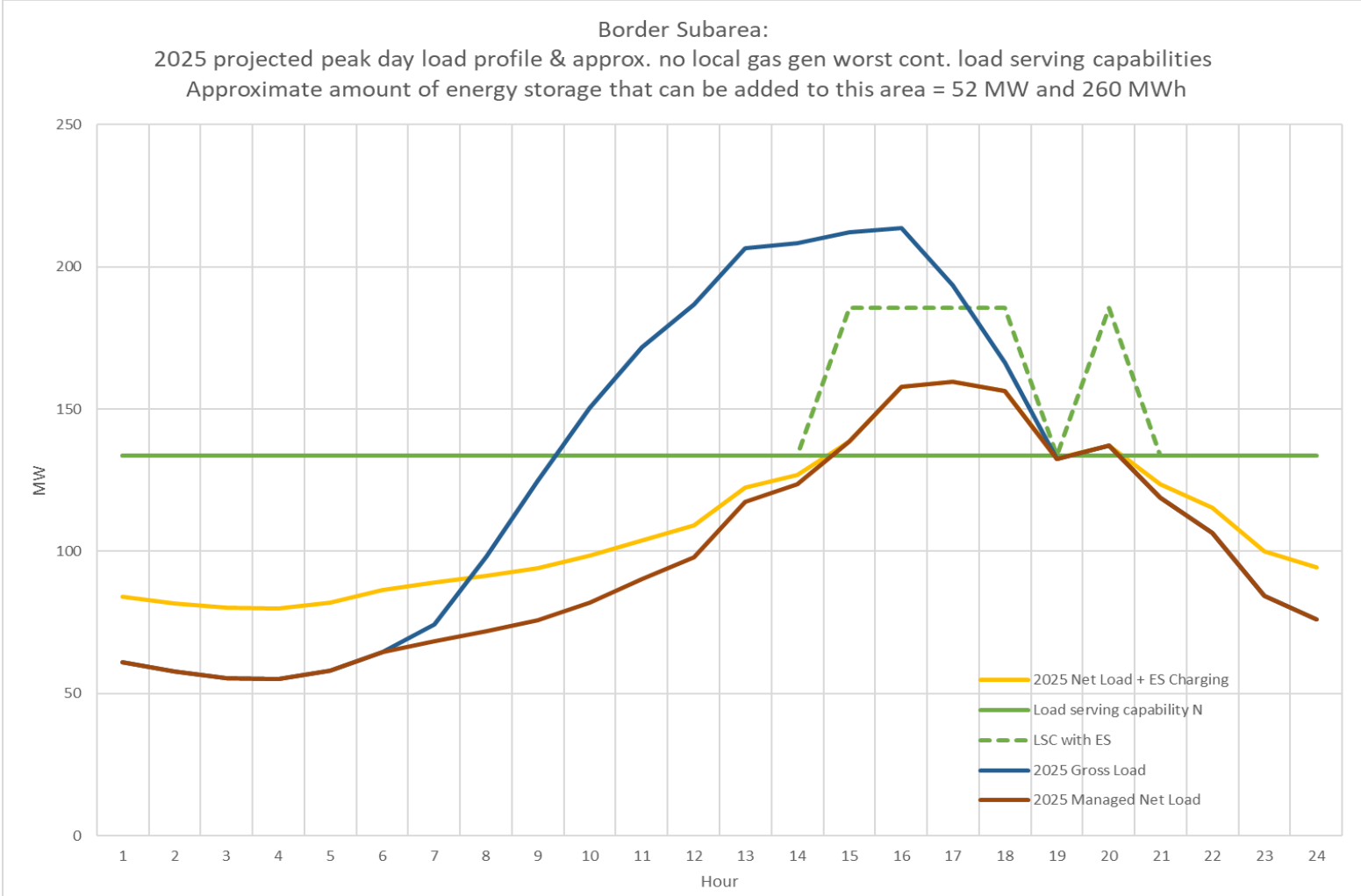

El Cajon Sub-area: Load and Resources

		2021	2025
Load (MW)	Gross Load	167	172
	AAEE	-2	-3
	Behand-The-Meter PV	0	0
	Net Load	165	169
	Transmission Loss	2	3
	Net Load + Loss	167	172
Resources (MW)	Gas-Fired	93.5	93.5
	Solar PV	0.0	0.0
	Wind	0.0	0.0
	QF/Other	0.0	0.0
	Demand Response	0	0
	Energy Storage	7.5	7.5

El Cajon Sub-area: One-line diagram

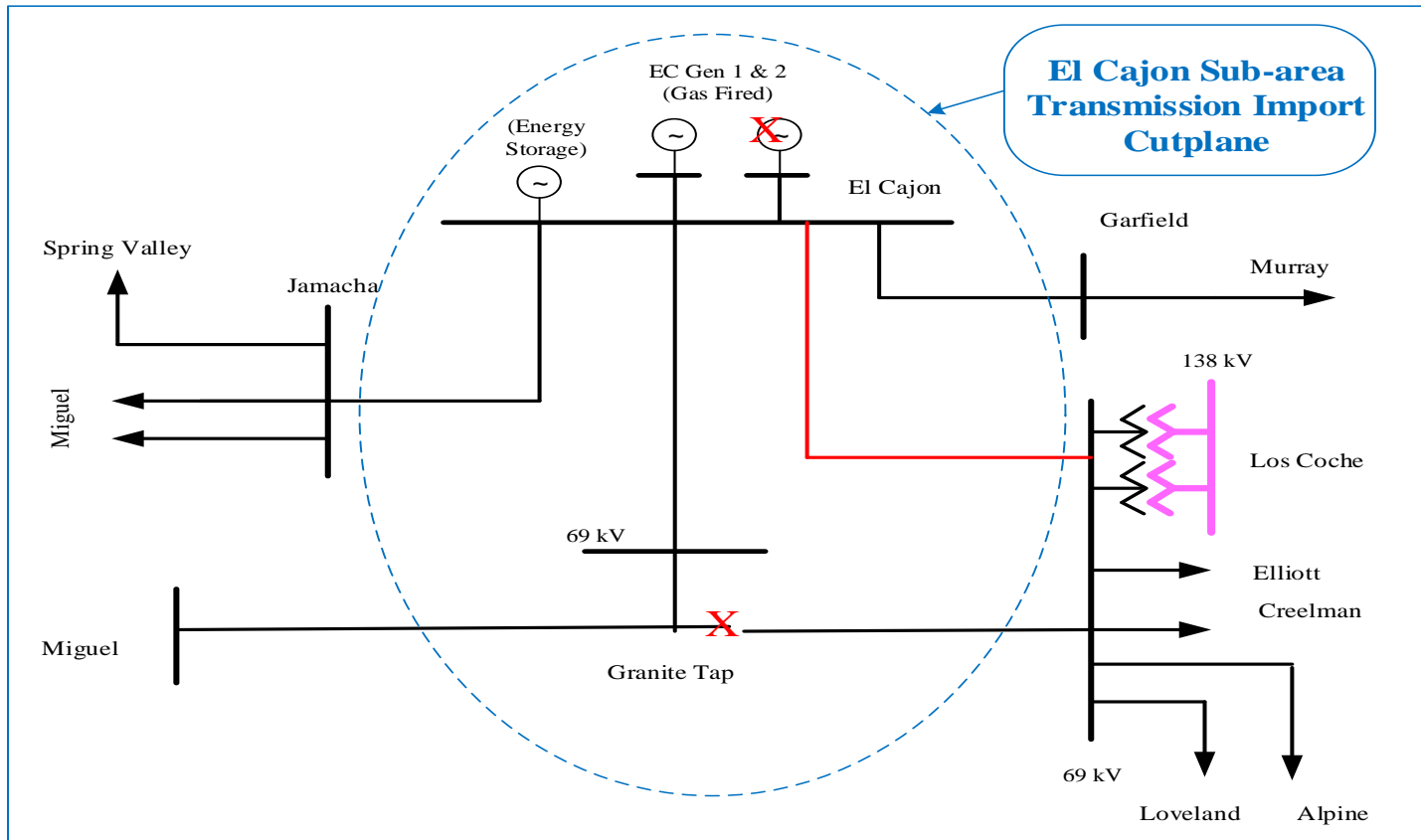

El Cajon Sub-area: LCR Requirement

Year	Category	Contingency	Limiting Facility	LCR (MW)
2021	P3	El Cajon unit out of service followed by the outage of TL632 Granite–Los Coches–Miguel 69 kV 3-terminal line	El Cajon-Los Coches 69 kV (TL631)	92
2025	P3	El Cajon unit out of service followed by the outage of TL632 Granite–Los Coches–Miguel 69 kV 3-terminal line	El Cajon-Los Coches 69 kV (TL631)	99

The LCR needs for the El Cajon sub-area will be eliminated with the completions of the TL632 Granite loop-in and TL6914 reconfiguration project, currently scheduled for 7/2029.