



2021 & 2025 Draft LCR Study Results Stockton Area

Ebrahim Rahimi

Lead Regional Transmission Engineer

Stakeholder Call

March 16, 2020

Stockton Area Transmission System & LCR Sub-areas

Tesla - Bellota

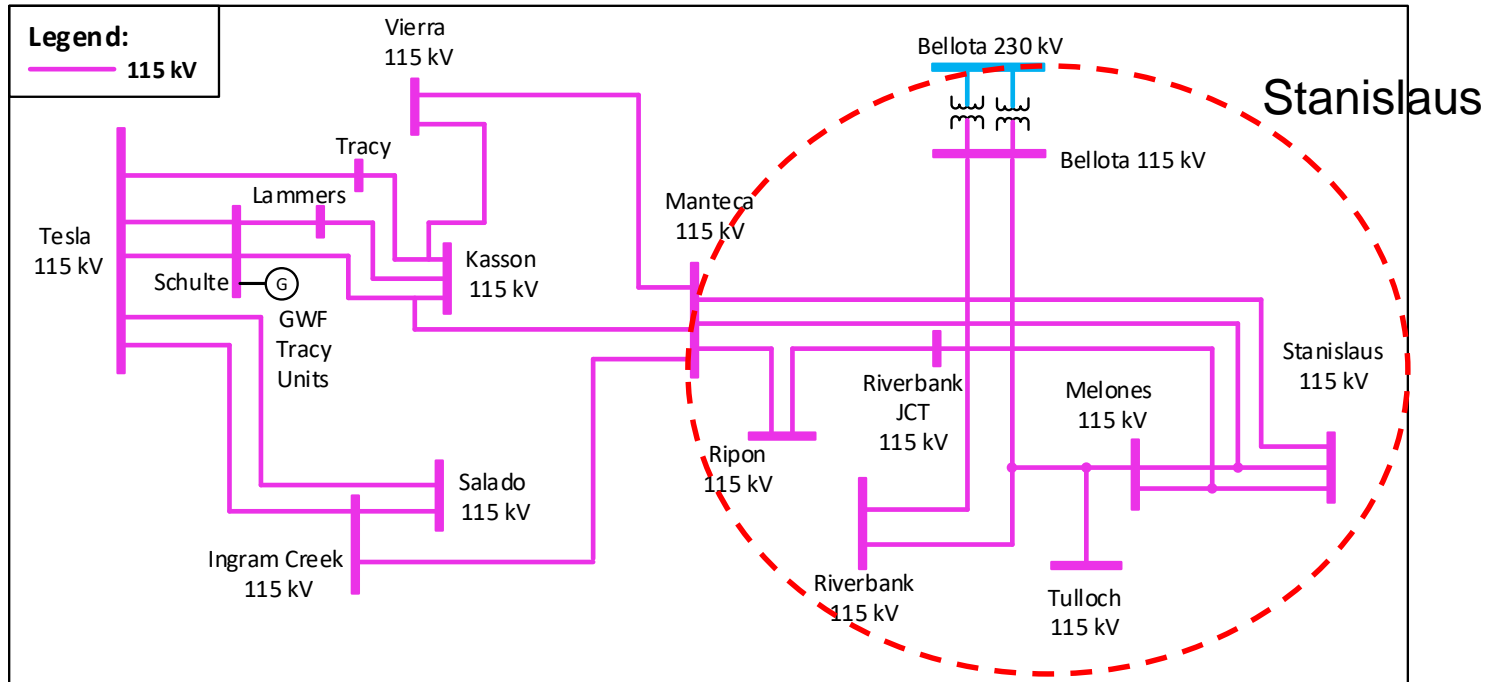

Lockeford

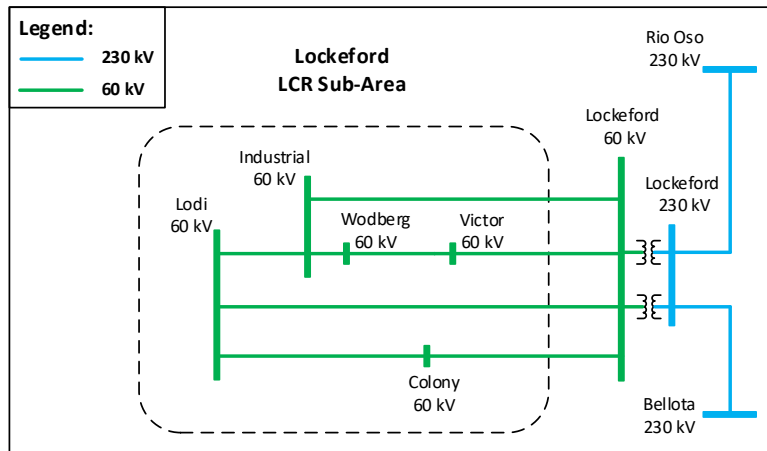

Weber was a sub-area within the Stockton area in the past, requiring generation to address P6 contingencies on 60 kV non-bulk system. However due to change in LCR criteria, Weber doesn't have any LCR requirement.

New major transmission projects

Project Name	Expected ISD
Year 2021	
Ripon 115 kV Line	Operational since May 2019
Stockton A – Weber #1 & #2 60 kV lines Reconductor	Operational since Aug. 2019
Year 2025	
Vierra 115 kV Looping Project	Jan-23
Tesla 230 kV Bus Series reactor	Dec-23
Lockeford-Lodi Area 230 kV Development	Jun-25

Power plant changes

Additions:

- No new resource addition

Retirements:

- No new retirements

Stockton Area Overall: Load and Resources

Load (MW)	2021	2025	Generation (MW)	2021	2025
Gross Load	1,338	1,385	Market/ Net Seller/ Battery	445	491
AAEE	-6	-12	Solar	1	1
Behind the meter DG	0	0	Wind	0	0
Net Load	1,332	1,375	Muni	140	116
Transmission Losses	24	22	QF	0	0
Pumps	0	0	Future preferred resource and energy storage	0	0
Load + Losses + Pumps	1,349	1,395	Total Qualifying Capacity	586	608

Lockeford Sub-Area : Requirements

Year	Category	Limiting Facility	Contingency	LCR (MW) (Deficiency)
2021	P3	Lockeford – Lodi #2 60 kV	Lockeford-Industrial 60 kV line and Lodi CT	36 (12)
2025	All	No requirements due to Lockeford-Lodi Area 230 kV Development project		

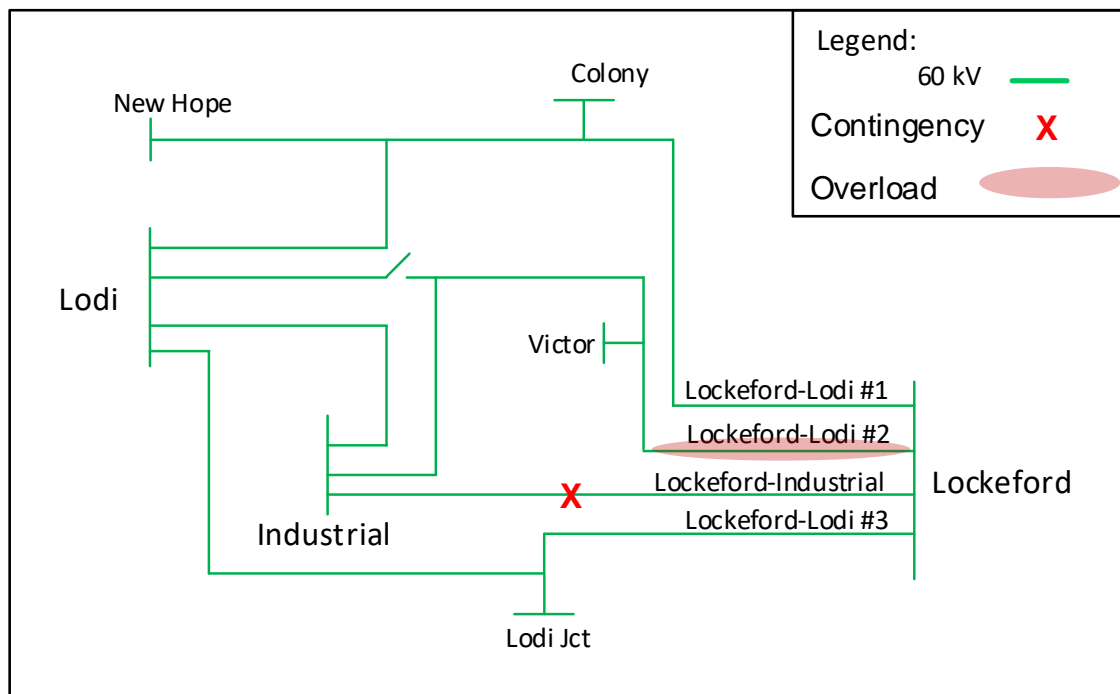

Stanislaus Sub-Area : Requirements

Year	Category	Limiting Facility	Contingency	LCR (MW) (Deficiency)
2021	P3	Manteca - Ripon 115 kV Line	Bellota-Riverbank-Melones 115 kV line and Stanislaus PH unit	205
2025	P3	Manteca - Ripon 115 kV Line	Bellota-Riverbank-Melones 115 kV line and Stanislaus PH unit	213 (1)

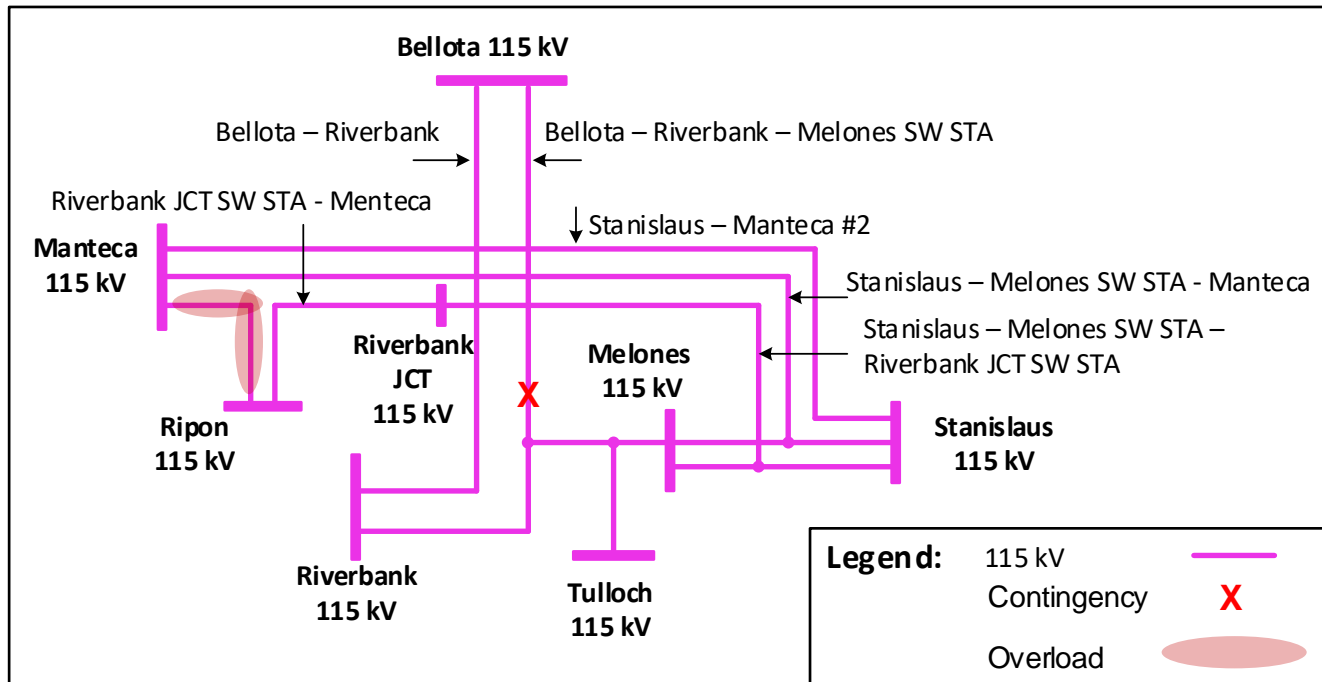

Tesla - Bellota Sub-Area : Requirements (2021)

Year	Category	Limiting Facility	Contingency	LCR (MW) (Deficiency)
2021	P2-4	Stanislaus – Melones – Riverbank Jct line	Tesla 115 kV bus	690 (128)
2021	P6	Schulte-Kasson-Manteca 115 kV line	Schulte – Lammers and Tesla – Tracy 115 kV lines	909 (657)
Total LCR Need in 2021				1,219 (657)

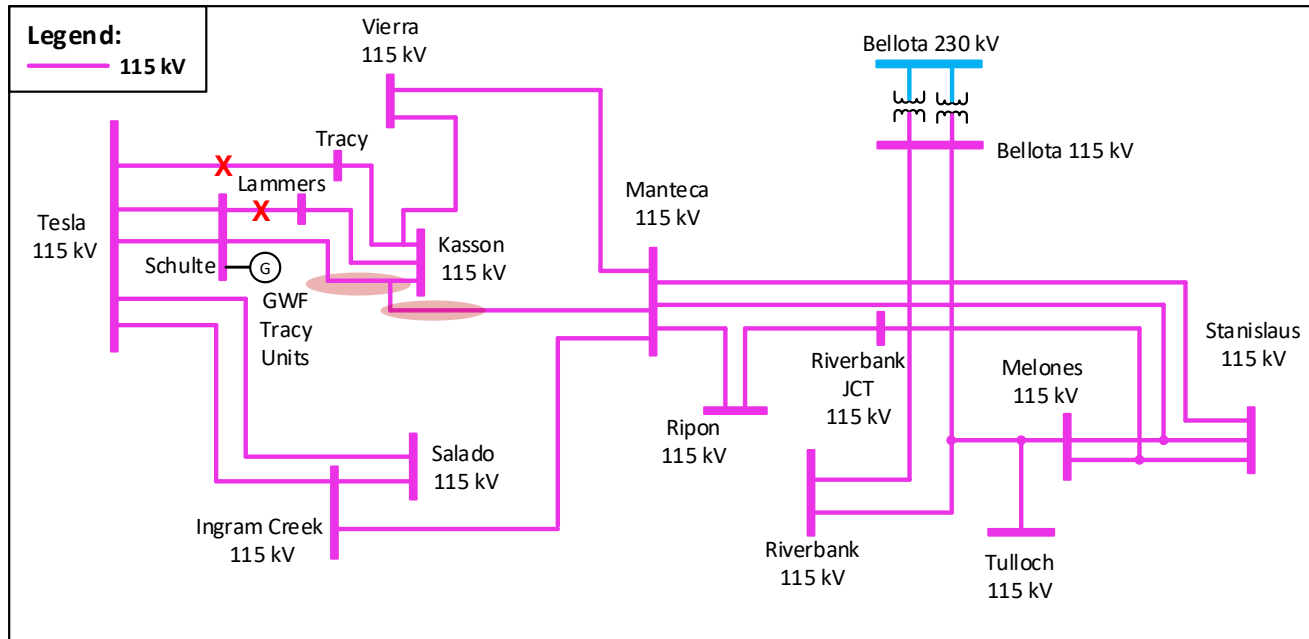

Tesla - Bellota Sub-Area : Requirements (2025)

Year	Category	Limiting Facility	Contingency	LCR (MW) (Deficiency)
2025	P2-4	Stanislaus – Melones – Riverbank Jct line	Tesla 115 kV bus	674 (66)
2025	P6	Tesla – Vierra 115 kV line	Schulte – Lammers and Schulte-Kasson-Manteca 115 kV lines	431 (133)
Total LCR Need in 2025				741 (133)

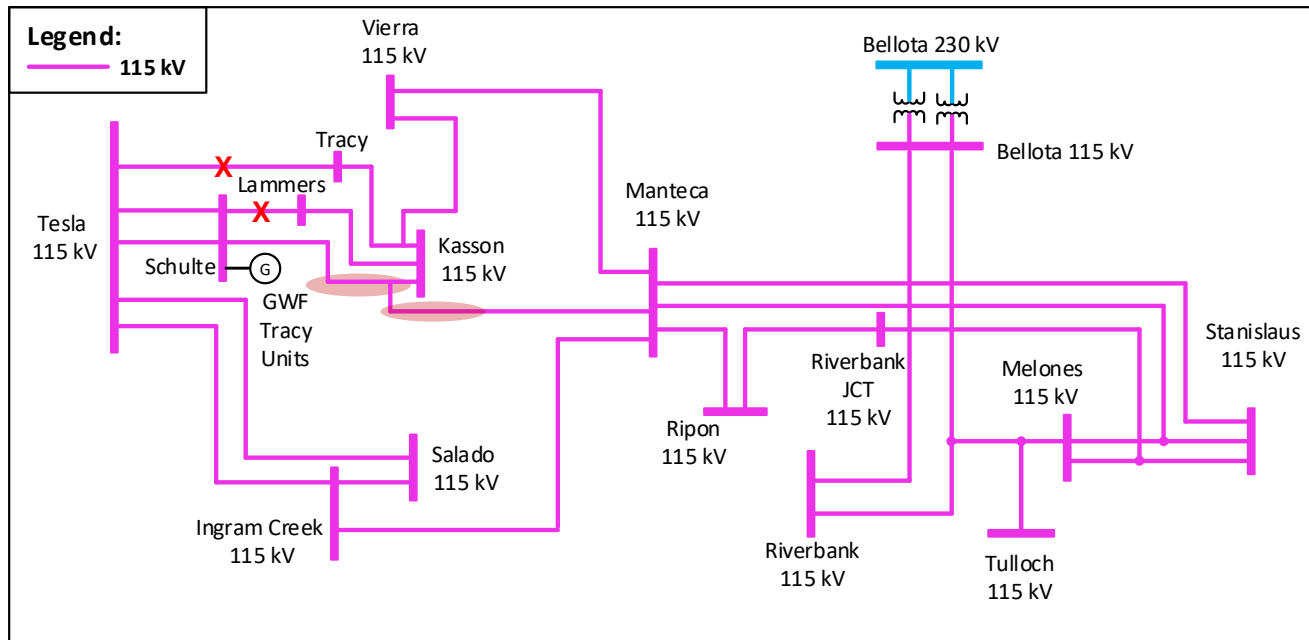

Changes from 2020 to 2021

Sub-area	2020		2021	
	Load	LCR	Load	LCR
Lockeford	190	97 (73)	194	36 (12)
Weber	238	26	243	N/A
Stanislaus	N/A	179	N/A	205
Tesla - Bellota	848	1,117 (543)	898	1,219 (657)
Total	1,275	1,241 (616)	1,349	1,255 (669)

LCR increases in sub-areas are mostly due to load increase. The LCR decreases in sub-areas are due to the change in criteria.

N/A=Flow-through area. No defined load pocket or not an LCR sub-area anymore

Changes from 2024 to 2025

Sub-area	2024		2025	
	Load	LCR	Load	LCR
Lockeford	193	102 (78)	198	N/A
Weber	238	26	247	N/A
Stanislaus	N/A	185	N/A	213 (1)
Tesla - Bellota	899	881 (260)	950	741 (133)
Total	1,330	1,009 (338)	1,395	741 (133)

Reduction in total LCR is due to transmission development or some sub-areas not being an LCR sub-area anymore due to change in LCR criteria.

N/A=Flow-through area. No defined load pocket.

Stockton Area Total LCR Need

Study Year	Existing Generation Capacity Needed (MW)	Deficiency (MW)	Total MW Need
2021	586	669	1,255
2025	608	133	741