



# 2021 & 2025 LCR Study Final Results Greater Bay Area

Binaya Shrestha

Manager Regional Transmission - North

Stakeholder Call

April 13, 2020

# Greater Bay Area Transmission System & LCR Sub-areas

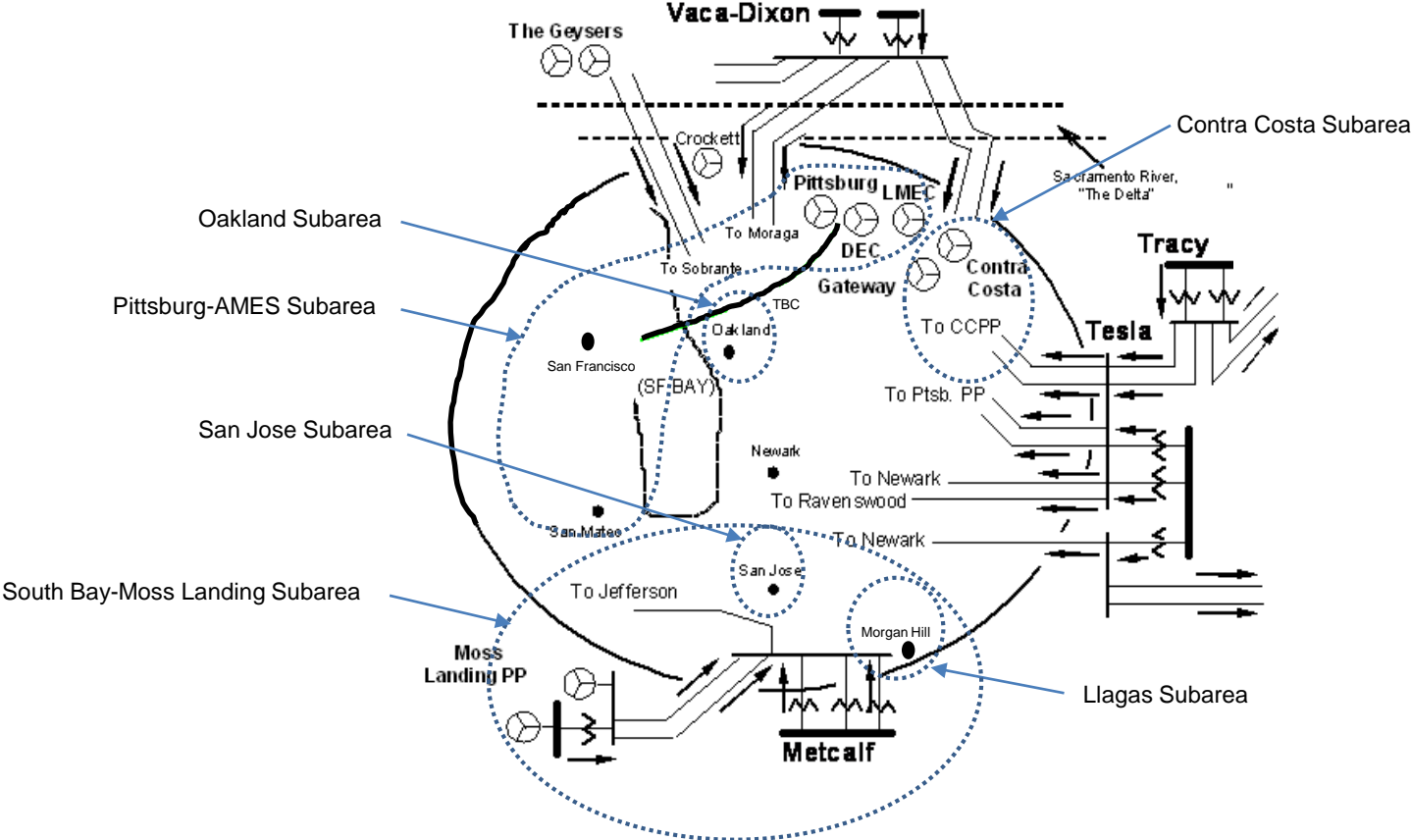

# New major transmission projects

Project Name	Expected ISD
East Shore-Oakland J 115 kV Reconductoring Project	Jun-22
Morgan Hill Area Reinforcement (revised scope)	Jul-21
Metcalf-Piercy & Swift and Newark-Dixon Landing 115 kV Upgrade	Apr-22
Oakland Clean Energy Initiative Project	Aug-22
Vaca Dixon-Lakeville 230 kV Corridor Series Compensation	Apr-21

# Power plant changes

## Additions:

- OCEI Energy Storage modeled in 2025
- Resolution E-4949 energy storage modeled in 2021 & 2025

## Retirements:

- One Oakland CT considered offline in 2021
- All Oakland CTs considered offline in 2025

## Llagas Sub-area: Load and Resources

Load (MW)	2021	2025	Generation (MW)	2021	2025
Gross Load	207	212	Market	246	246
AAEE	-2	-3	Wind	0	0
Behind the meter DG	-6	-8	Muni	0	0
<b>Net Load</b>	<b>199</b>	<b>201</b>	QF	0	0
Transmission Losses	0	0	Future preferred resource and energy storage	0	0
Pumps	0	0	<b>Total Qualifying Capacity</b>	<b>246</b>	<b>246</b>
<b>Load + Losses + Pumps</b>	<b>199</b>	<b>201</b>			

# Llagas Sub-area: One-line diagram

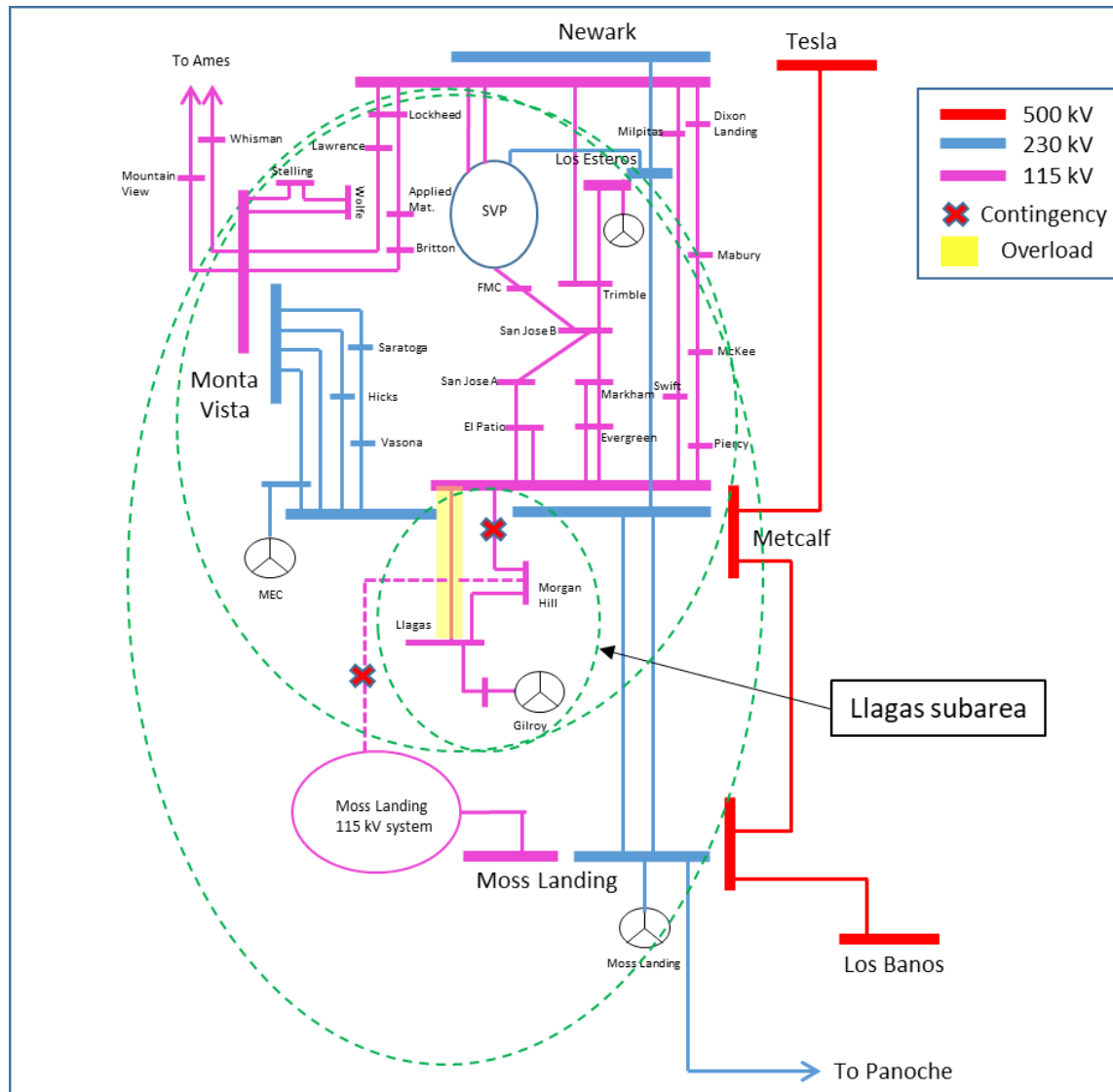

# Llagas Sub-area: Requirements

Year	Category	Limiting Facility	Contingency	LCR (MW)
2021	P6	Metcalf-Llagas 115 kV line	Metcalf-Morgan Hill & Morgan Hill-Green Valley 115kV	31
2025	P6	Metcalf-Llagas 115 kV line	Metcalf-Morgan Hill & Morgan Hill-Green Valley 115kV	33

# Llagas Sub-area: Load Profiles

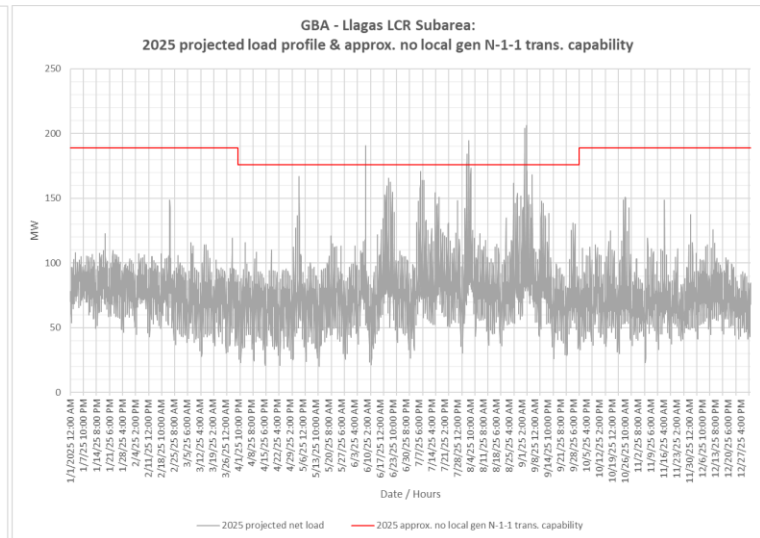
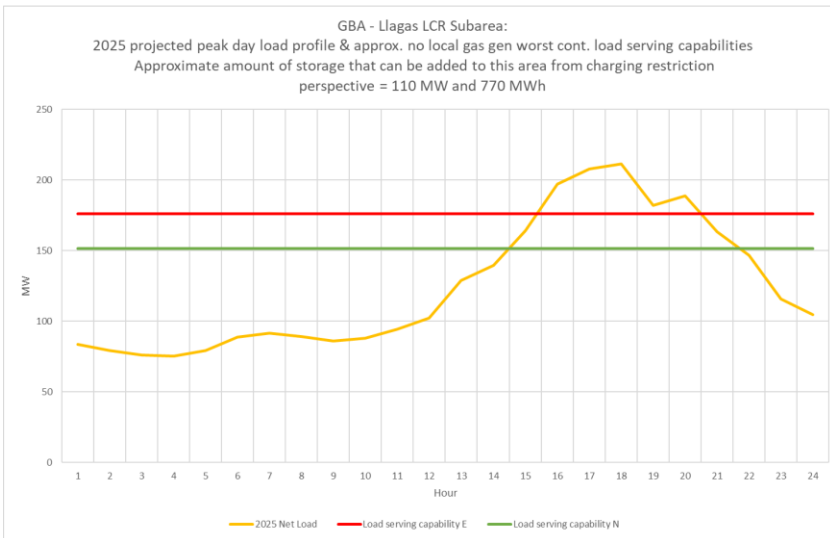
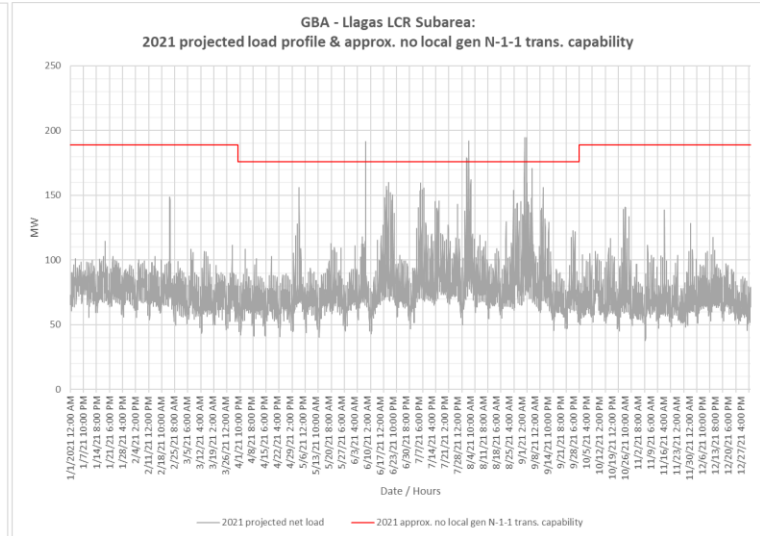
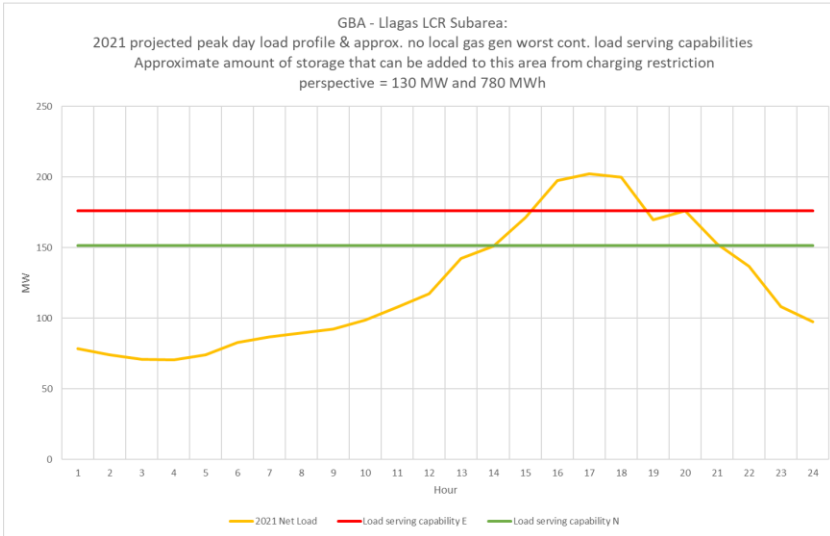



## San Jose Sub-area: Load and Resources

Load (MW)	2021	2025	Generation (MW)	2021	2025
Gross Load	2,531	2,544	Market	575	575
AAEE	-16	-32	Wind	0	0
Behind the meter DG	-38	-53	Muni	198	198
<b>Net Load</b>	<b>2,477</b>	<b>2,459</b>	QF	0	0
Transmission Losses	66	68	Future preferred resource and energy storage	75	75
Pumps	0	0	<b>Total Qualifying Capacity</b>	<b>848</b>	<b>848</b>
<b>Load + Losses + Pumps</b>	<b>2,543</b>	<b>2,527</b>			

# San Jose Sub-area: One-line diagram

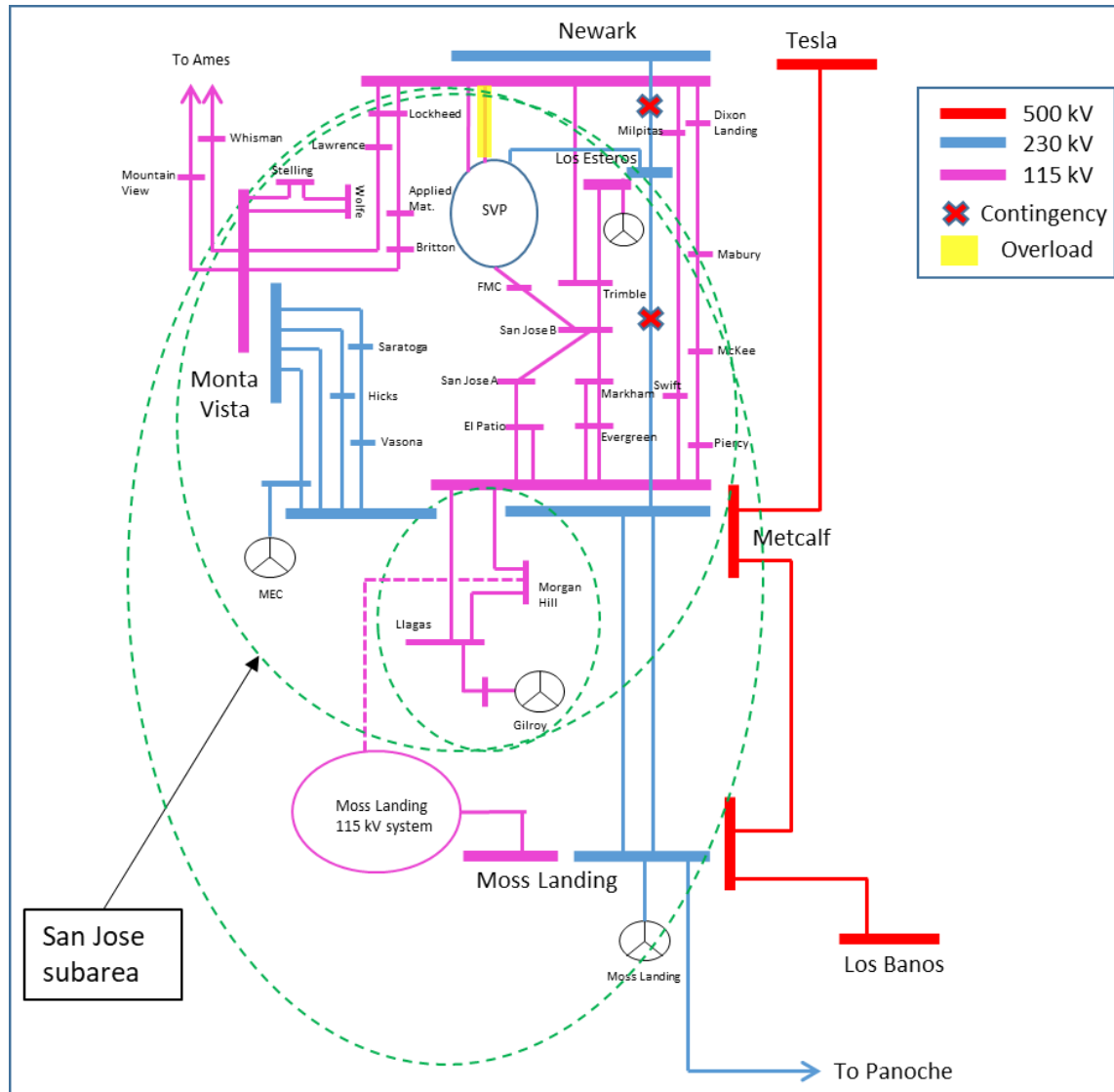

# San Jose Sub-area: Requirements

Year	Category	Limiting Facility	Contingency	LCR (MW) (deficiency)
2021	P2-4	Metcalf 230/115 kV transformer # 1 or # 3	METCALF 230kV - Section 2D & 2E	793
2025	P2-4	Metcalf 230/115 kV transformer # 1 or # 3	METCALF 230kV - Section 2D & 2E	862 (14)

# San Jose Sub-area: Load Profiles

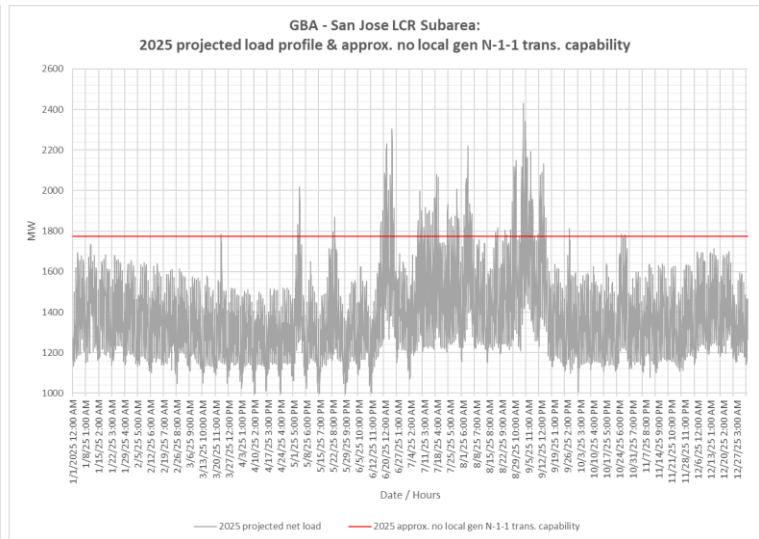
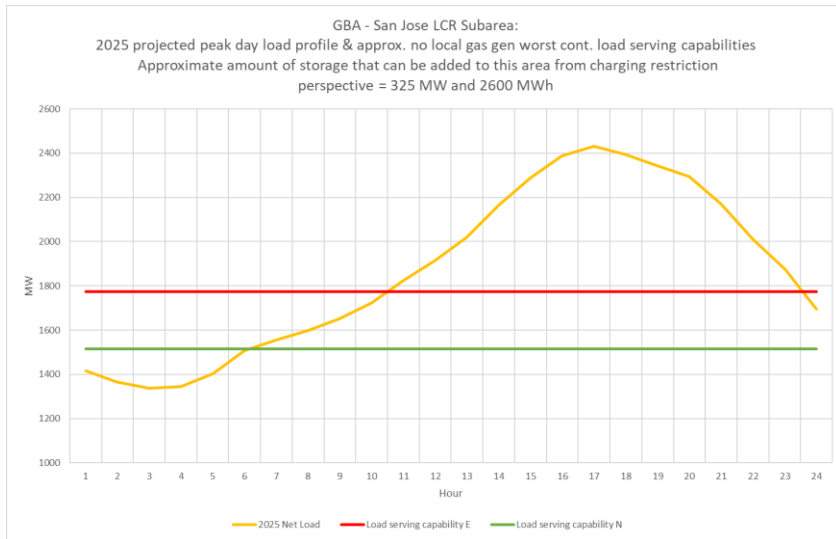
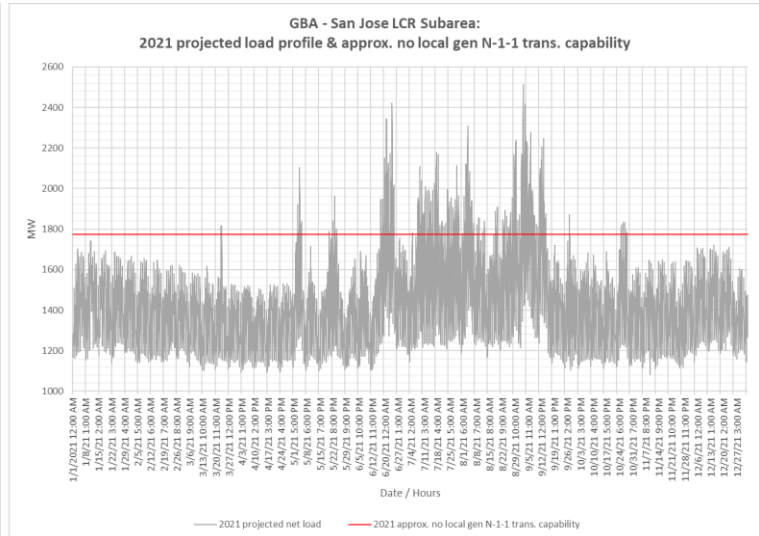
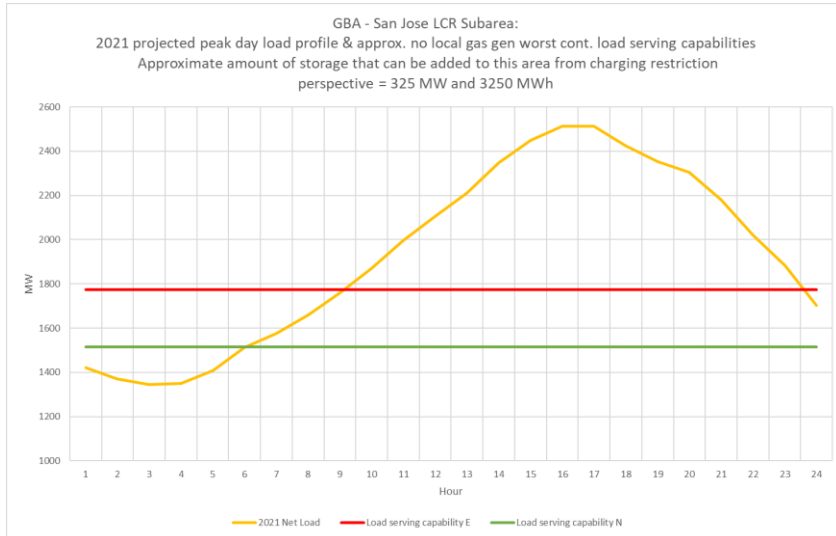

# South Bay-Moss Landing Sub-area: Load and Resources

Load (MW)	2021	2025	Generation (MW)	2021	2025
Gross Load	4139	4165	Market	2165	2165
AAEE	-26	-52	Wind	0	0
Behind the meter DG	-76	-101	Muni	198	198
<b>Net Load</b>	<b>4,037</b>	<b>4,012</b>	QF	0	0
Transmission Losses	108	112	Future preferred resource and energy storage	558	558
Pumps	0	0	<b>Total Qualifying Capacity</b>	<b>2,921</b>	<b>2,921</b>
<b>Load + Losses + Pumps</b>	<b>4,145</b>	<b>4124</b>			

# South Bay-Moss Landing Sub-area: One-line diagram

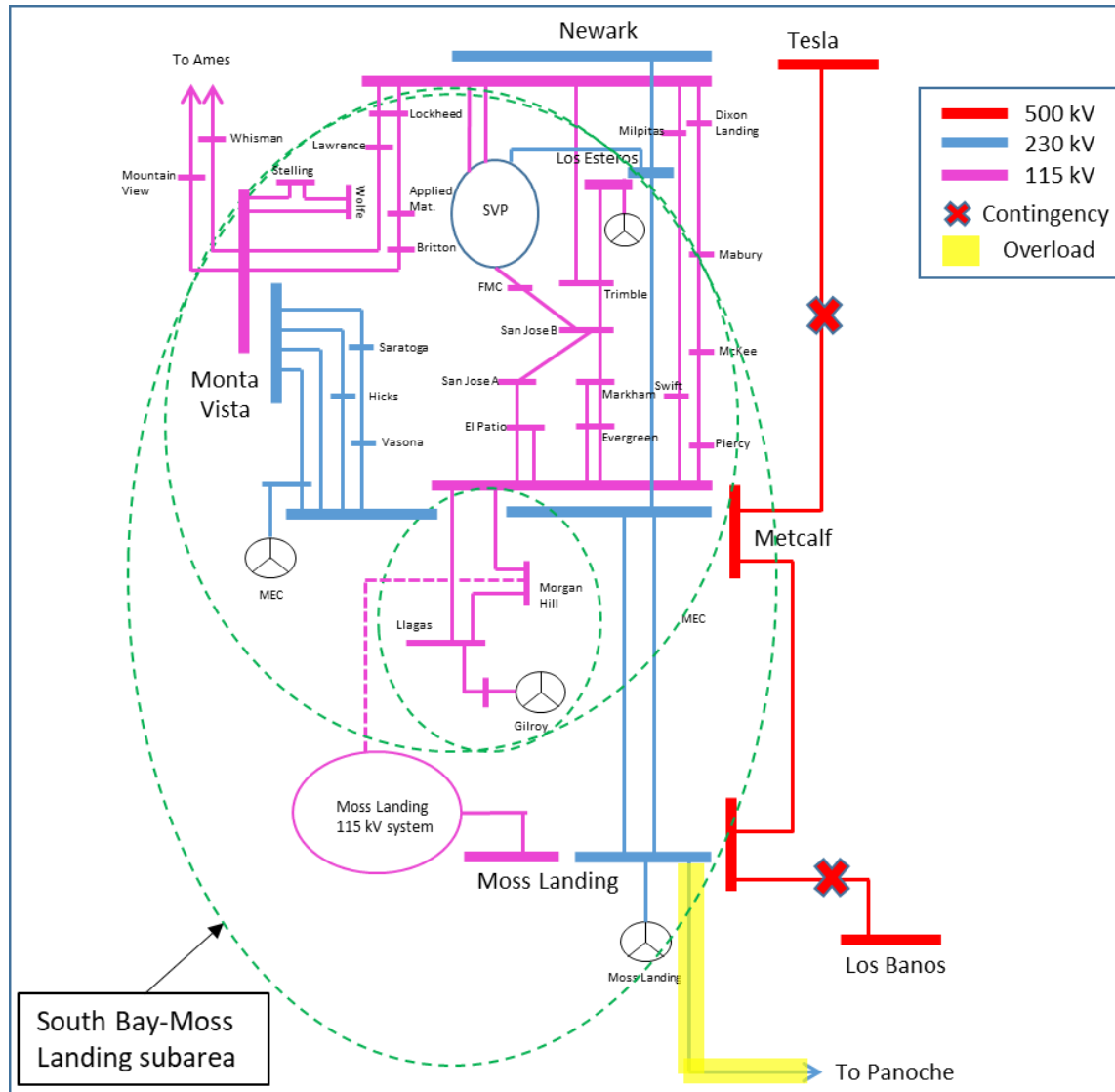

# South Bay-Moss Landing Sub-area: Requirements

Year	Category	Limiting Facility	Contingency	LCR (MW)
2021	P6	Moss Landing-Las Aguilas 230 kV	Tesla-Metcalf 500 kV and Moss Landing-Los Banos 500 kV	1783
2025	P6	Moss Landing-Las Aguilas 230 kV	Tesla-Metcalf 500 kV and Moss Landing-Los Banos 500 kV	1784

# South Bay-Moss Landing Sub-area: Load Profiles

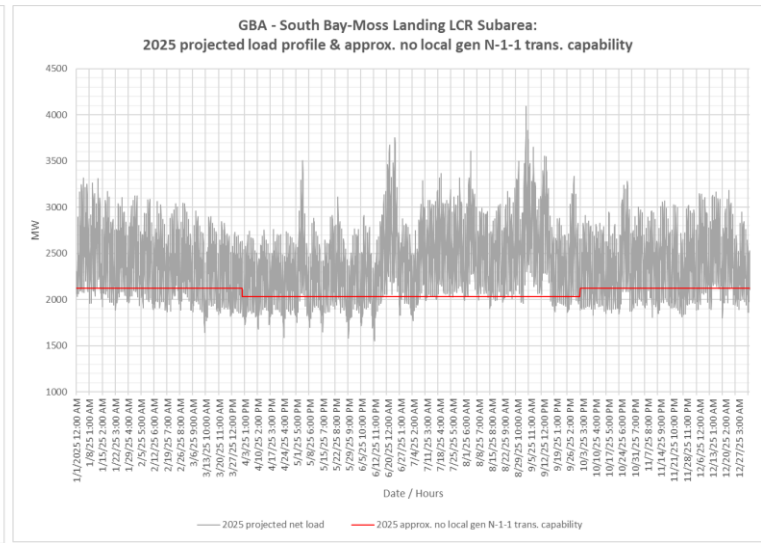
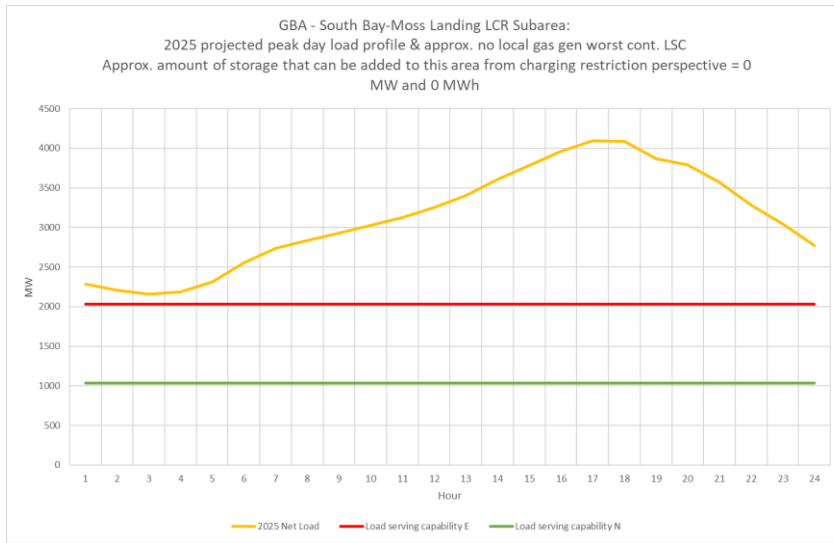
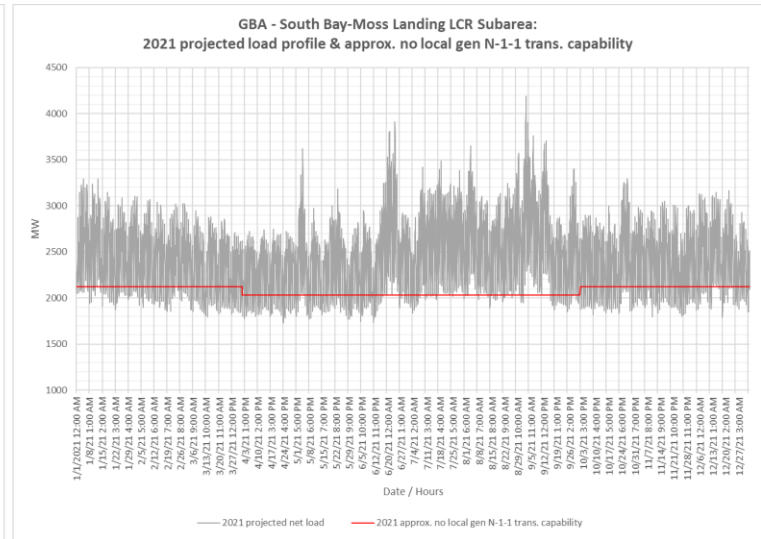
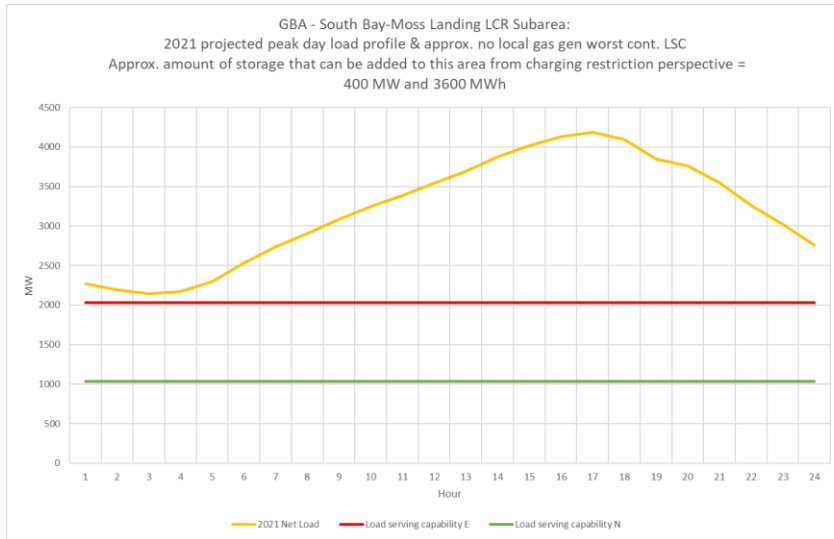



## Oakland Sub-area: Load and Resources

Load (MW)	2021	2025	Generation (MW)	2021	2025
Gross Load	221	225	Market	110	0
AAEE	-1	-3	Wind	0	0
Behind the meter DG	-2	-3	Muni	48	48
<b>Net Load</b>	<b>218</b>	<b>219</b>	QF	0	0
Transmission Losses	0	0	Future preferred resource and energy storage	0	36
Pumps	0	0	<b>Total Qualifying Capacity</b>	<b>158</b>	<b>84</b>
<b>Load + Losses + Pumps</b>	<b>218</b>	<b>219</b>			

# Oakland Sub-area: One-line diagram

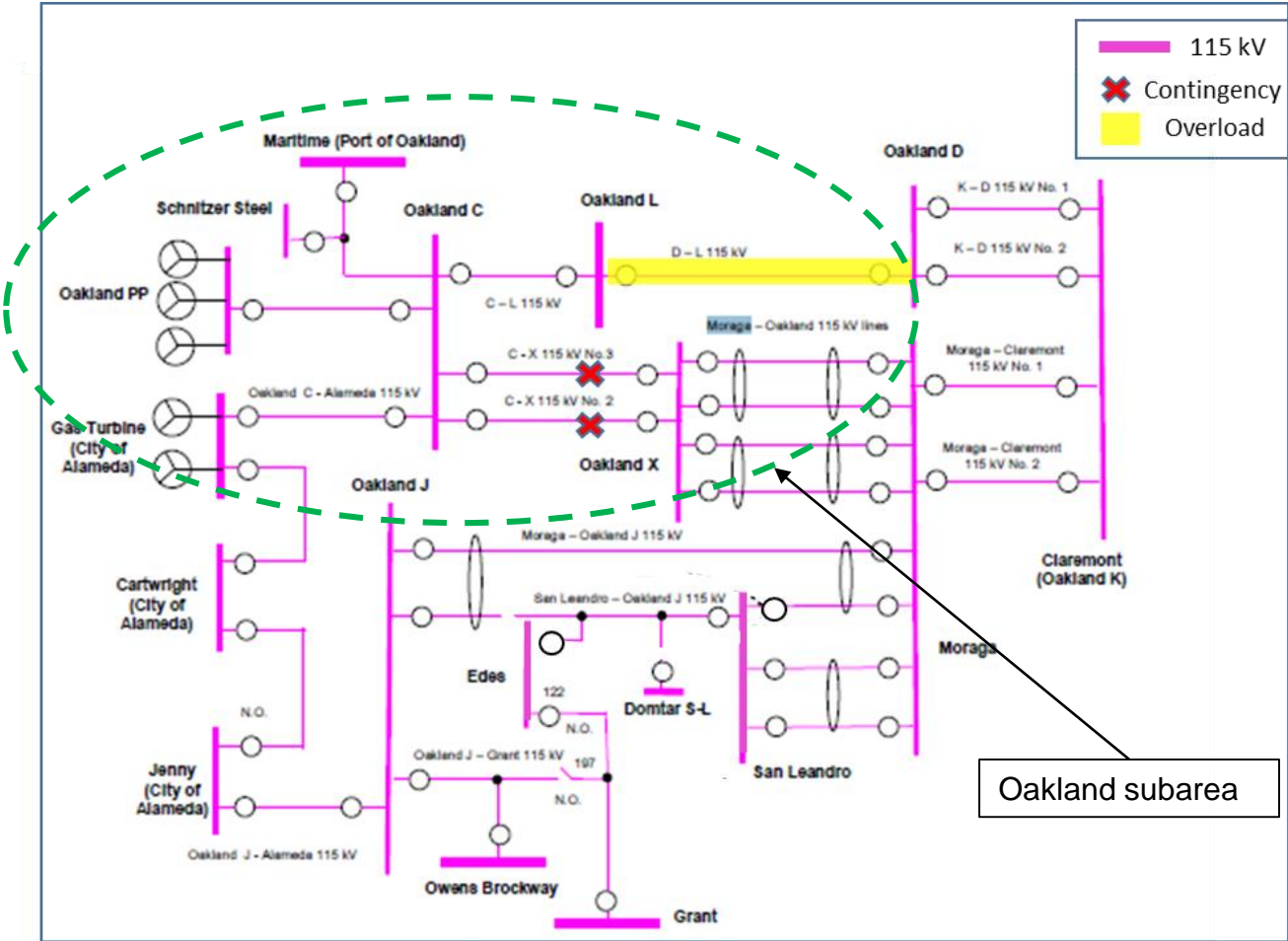

# Oakland Sub-area: Requirements

Year	Category	Limiting Facility	Contingency	LCR (MW)
2021	P2-4	Moraga-Oakland X #3 or #4 115 kV line	Moraga 115kV - Section 1D & 2D	99
2025	P6	Moraga-Claremont #2 115 kV	Oakland C-X #2 & #3 115 kV cables	71 <sup>1</sup>

Note:

<sup>1</sup> This requirement doesn't reflect potential load transfer that could occur following the first contingency. An approved operating procedure including this load transfer could reduce this requirement.

# Oakland Sub-area: Load Profiles

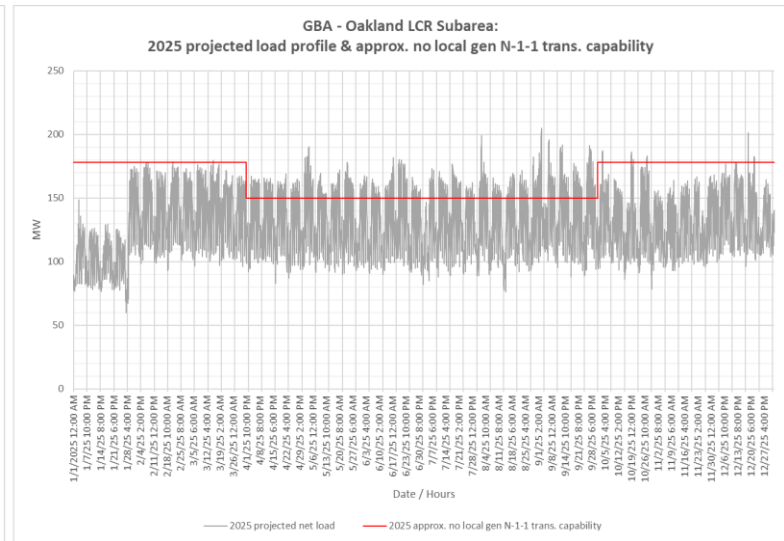
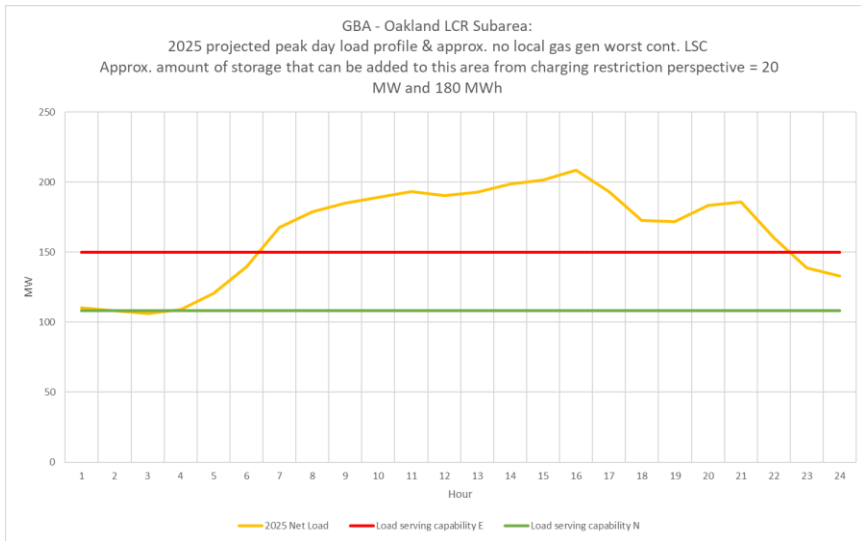
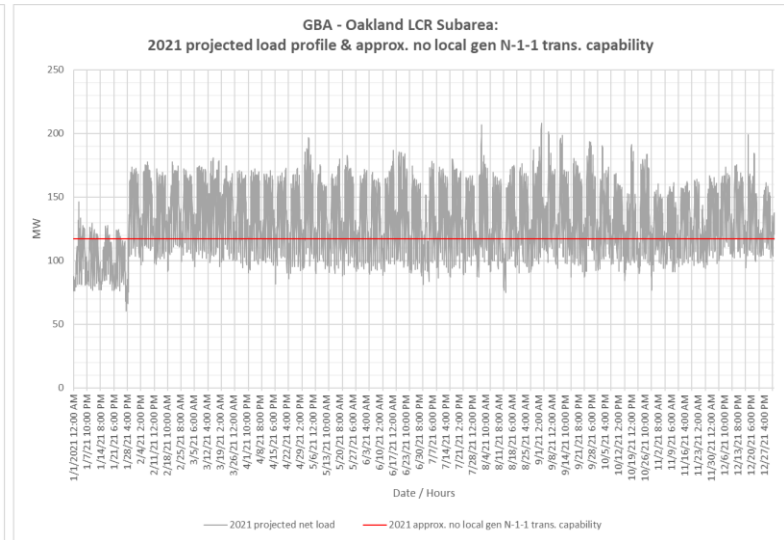
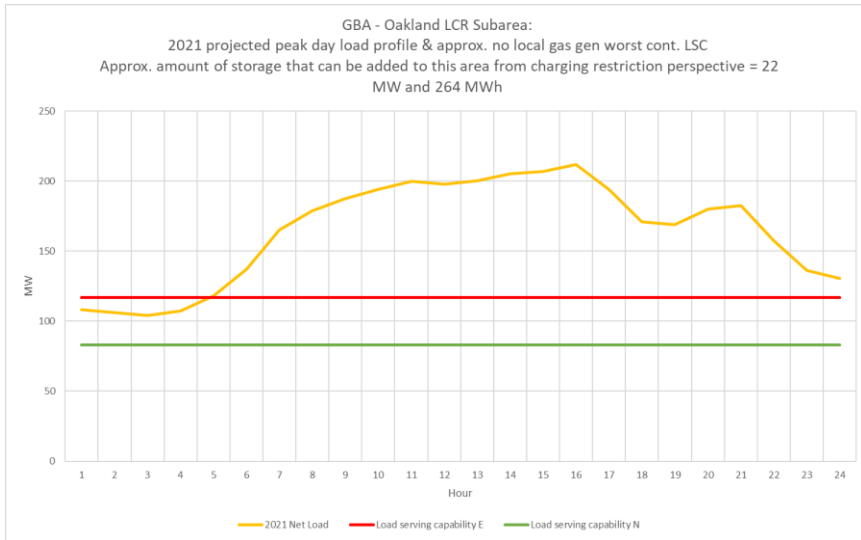

# Pittsburg-Ames-Oakland Sub-area: Load and Resources

Load (MW)	2021	2025	Generation (MW)	2021	2025
Gross Load	<b>NA – Flow through area.</b>		Market/ Net Seller / Battery	2152	2042
AAEE			Solar	5	5
Behind the meter DG			Wind	0	0
<b>Net Load</b>			Muni	48	48
Transmission Losses			QF	225	225
Pumps			Future preferred resource and energy storage	0	36
<b>Load + Losses + Pumps</b>			<b>Total Qualifying Capacity</b>	<b>2,430</b>	<b>2,356</b>

# Ames/Pittsburg/Oakland Sub-area: One-line diagram

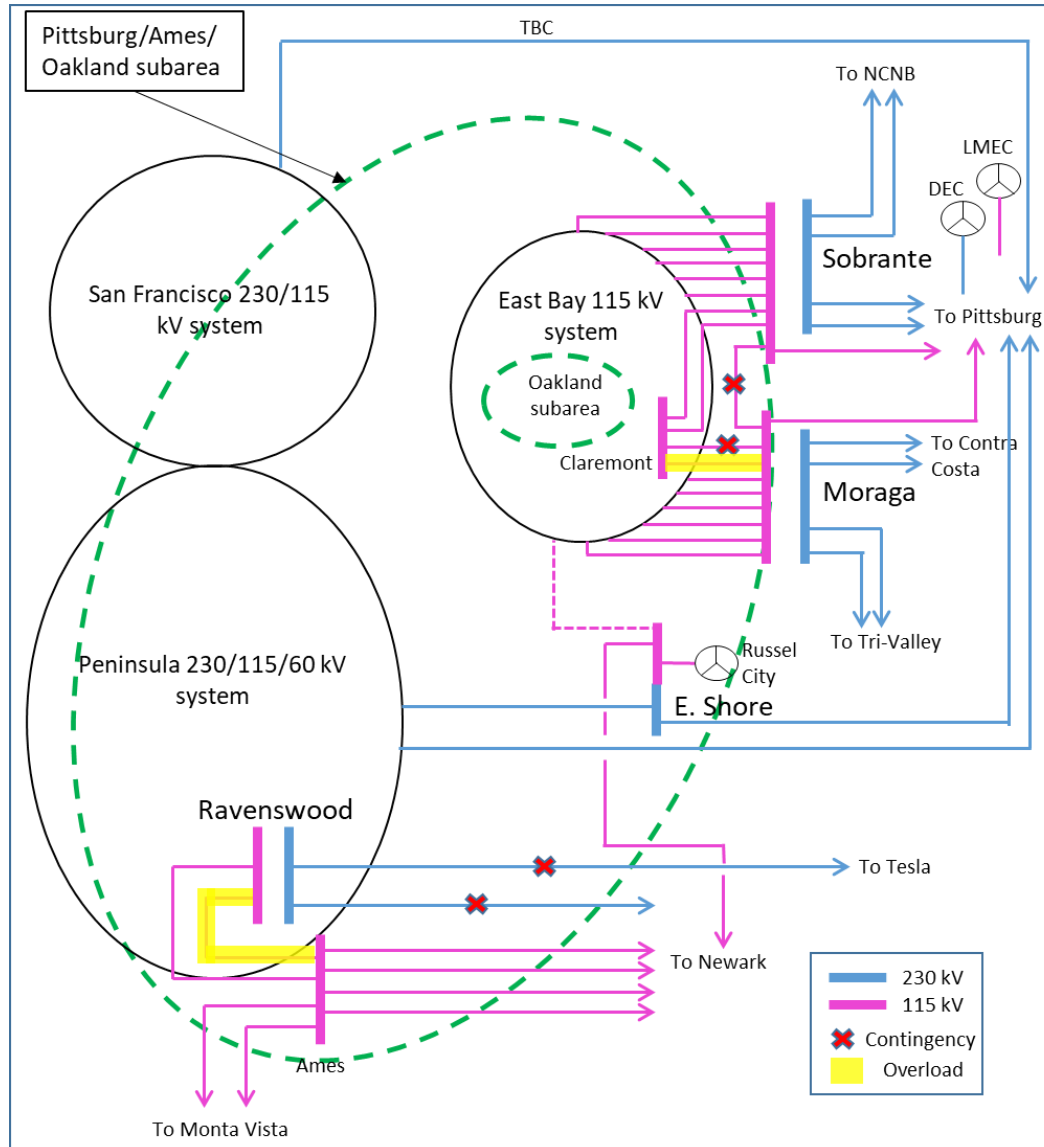

# Ames/Pittsburg/Oakland Sub-area: Requirements

Year	Category	Limiting Facility	Contingency	LCR (MW) (Deficiency)
2021	P7	Ames-Ravenswood #1 115 kV line	Newark-Ravenswood & Tesla-Ravenswood 230 kV lines	1967
	P2-4	Moraga-Claremont #2 115 kV line	Moraga 115 kV - Section 2D & 2E	
2025	P7	Ames-Ravenswood #1 115 kV line	Newark-Ravenswood & Tesla-Ravenswood 230 kV lines	1761
	P2-4	Martinez-Sobrante 115 kV line	Pittsburg Section 1D & 1E 230 kV	

# Contra Costa Sub-area: Load and Resources

Load (MW)	2021	2025	Generation (MW)	2021	2025
Gross Load	<b>NA – Flow through area.</b>		Market	1669	1669
AAEE			Wind	244	244
Behind the meter DG			Muni	127	127
<b>Net Load</b>			QF	0	0
Transmission Losses			Future preferred resource and energy storage	0	0
Pumps			<b>Total Qualifying Capacity</b>	<b>2,040</b>	<b>2,040</b>
<b>Load + Losses + Pumps</b>					



# Contra Costa Sub-area: One-line diagram

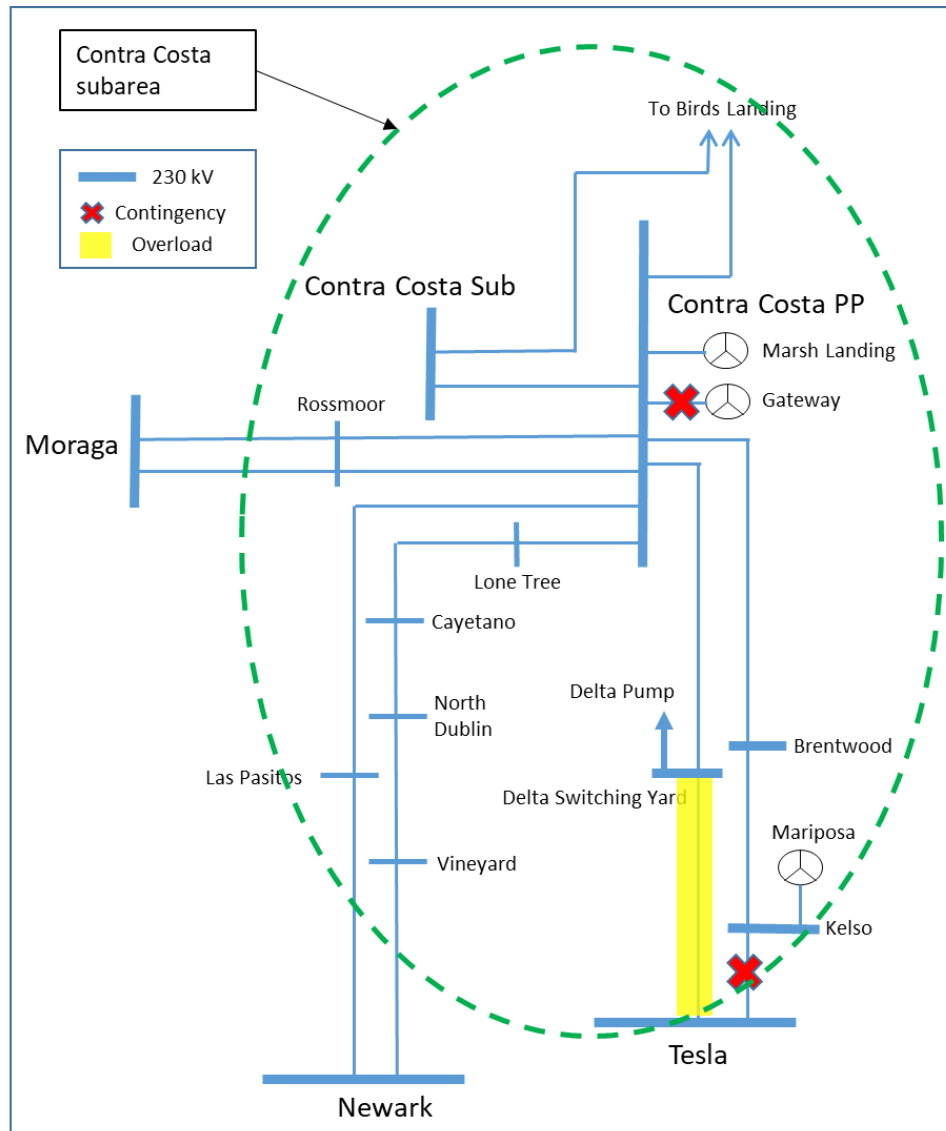

# Contra Costa Sub-area: Requirements

Year	Category	Limiting Facility	Contingency	LCR (MW) (Deficiency)
2021	P3	Delta Switching Yard-Tesla 230 kV Line	Kelso-Tesla 230 kV with the Gateway off line	1119
2025	P3	Delta Switching Yard-Tesla 230 kV Line	Kelso-Tesla 230 kV with the Gateway off line	1417

## Greater Bay Area Overall: Load and Resources

Load (MW)	2021	2025	Generation (MW)	2021	2025
Gross Load	10,508	10,606	Market/ Net Seller/ Battery	6,004	5,895
AAEE	-57	-120	Solar	8	8
Behind the meter DG	-179	-247	Wind	244	244
<b>Net Load</b>	<b>10,272</b>	<b>10,239</b>	Muni	377	377
Transmission Losses	244	240	QF	227	227
Pumps	264	264	Future preferred resource and energy storage	558	593
<b>Load + Losses + Pumps</b>	<b>10,780</b>	<b>10,743</b>	<b>Total Qualifying Capacity</b>	<b>7,418</b>	<b>7,344</b>

# Greater Bay Area Overall: Requirements

Year	Category	Limiting Facility	Contingency	LCR (MW)
2021	P6	Metcalf 500/230 kV #13 transformer	Metcalf 500/230 kV #11 & #12 transformers	6353
2025	P6	Metcalf 500/230 kV #13 transformer	Metcalf 500/230 kV #11 & #12 transformers	6110

# Greater Bay Area Total Generation & LCR Need

Generation	Market (MW)	Wind (MW)	Muni (MW)	QF (MW)	Future preferred resource and energy storage (MW)	Total MW
2021	6013	244	377	227	558	7419
2025	5903	244	377	227	593	7344

Year	Existing Generation Capacity Needed (MW)	Deficiency (MW)	Total MW Need
2021	6353	0	6353
2025	6110	14	6124

# Changes Compared to Previous Year's LCR Requirements

Sub-area	2020		2021		2024		2025	
	Load	LCR	Load	LCR	Load	LCR	Load	LCR
Llagas	180	79	199	31	177	16	201	33
San Jose	2462	305	2543	793	2527	462	2527	862(14)
South Bay – Moss Landing	4062	1781	4145	1783	4091	1781	4124	1784
Oakland	187	32	218	99	179	27	219	71
Pittsburg – Ames – Oakland	NA*	1614	NA*	1967	NA*	1563	NA*	1761
Contra Costa	NA*	1155	NA*	1119	NA*	1051	NA*	1417
Overall	10488	4550	10780	6353	10427	4395	10743	6110

Note:

\* Flow-through area. No defined load pocket.