

APPENDIX I: Description and Functional Specifications for Transmission Facilities Eligible for Competitive Solicitation

Intentionally left blank

Overview

The ISO has recommended the following policy-driven projects for approval that are eligible for competitive solicitation:

- Imperial Valley – North of SONGS 500 kV Line and Substation;
- North of SONGS – Serrano 500 kV Line;
- North Gila – Imperial Valley 500 kV Transmission Line; and

The Imperial Valley – North of SONGS 500 kV Line and Substation, North of SONGS – Serrano 500 kV Line, and North Gila – Imperial Valley 500 kV Transmission Line are part of the Southern Area Reinforcement projects to address the Devers-Red Bluff 500 kV, East of Miguel, Bay Boulevard-Silvergate, Encina-San Luis Rey, Sycamore area, San Luis Rey-San Onofre, and Silvergate-Old Town constraints.

More information on these projects are provided in Chapter 3 and Appendix F.

The following sections contain detailed descriptions and functional specifications for these **three** projects.

I.1 Description and Functional Specifications of Proposed Policy-Driven Imperial Valley – North of SONGS 500 kV Line and 500/230 kV Substation Project

I.2.1 Description

In the 2022-2023 Transmission Plan, the ISO has identified a policy-driven need for the Imperial Valley – North of SONGS 500 kV Line and 500/230 kV Substation project as part of the Southern Area Reinforcement Projects. Figure I.1-1 provides a schematic diagram of the transmission system in the area. As shown in the figure, the project scope includes the following:

- New 500/230 kV substation north of SONGS complete with three (3) 500/230 kV transformers
- Loop the San Onofre–Santiago 230 kV 1 and 2 lines and the San Onofre–Viejo 230 kV line into the new substation.
- New Imperial Valley–N.SONGS 500 kV line, estimated at 145 miles, with 50% series compensation and line reactors.

Figure I.1-1: Schematic Diagram of the Imperial Valley – North of SONGS 500 kV Line and 500/230 kV Substation project

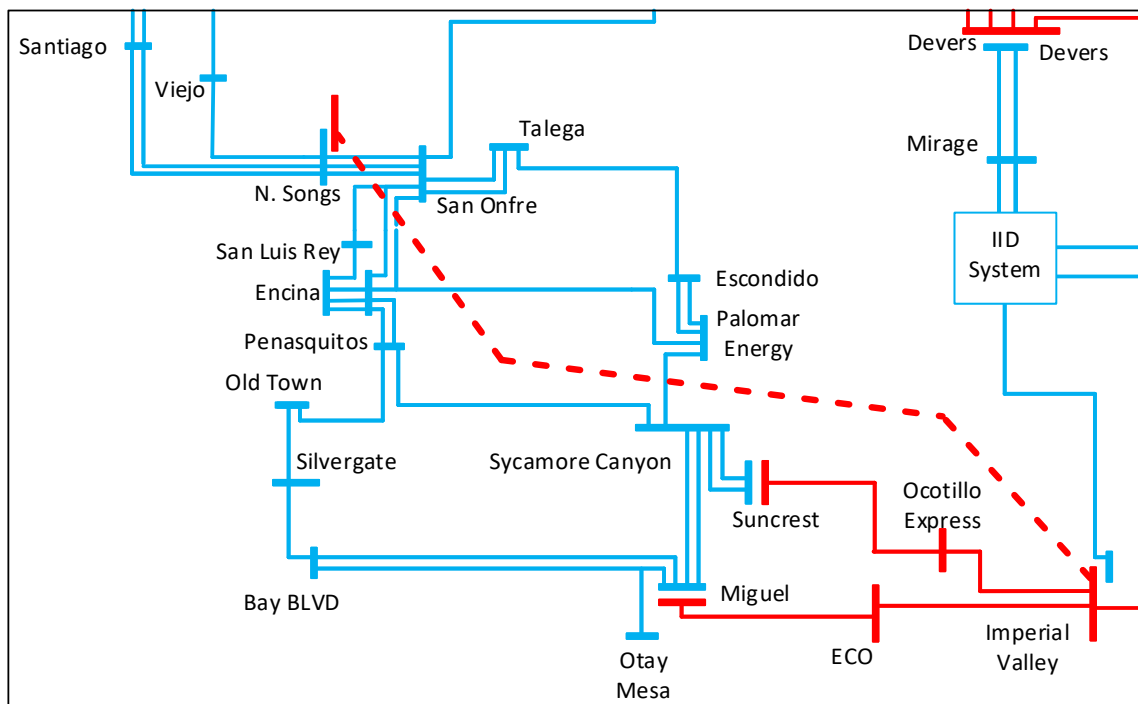

The ISO estimates that the proposed project will approximately cost \$2,228 million including both the competitive solicitation and directly assigned components. The ISO recognizes there may be some uncertainty regarding routing and siting of the 500 kV AC transmission line during the siting and permitting process for this project. As such, the ISO will seek cost and risk

mitigation strategies from project sponsors' in their bid applications in the competitive solicitation process along with potential alternatives and mitigation measures if significant undergrounding of the line is required. The project need date is 2030 and the expected in-service date is 2034. The requested in-service date is by 2030 but not later than June 1st 2034.

The location of the North of SONGS 500/230 kV substation is expected to be within a boundary that is approximately 10 miles north of the existing SONGS 230 kV substation and approximately 2 miles away from the 230 kV line corridor.

Figure I.1-2 provides a schematic diagram of the new North of SONGS substation with the initial and the ultimate plan.

Figure I.1-2: Schematic Diagram of the North of Songs 500/230 kV Substation

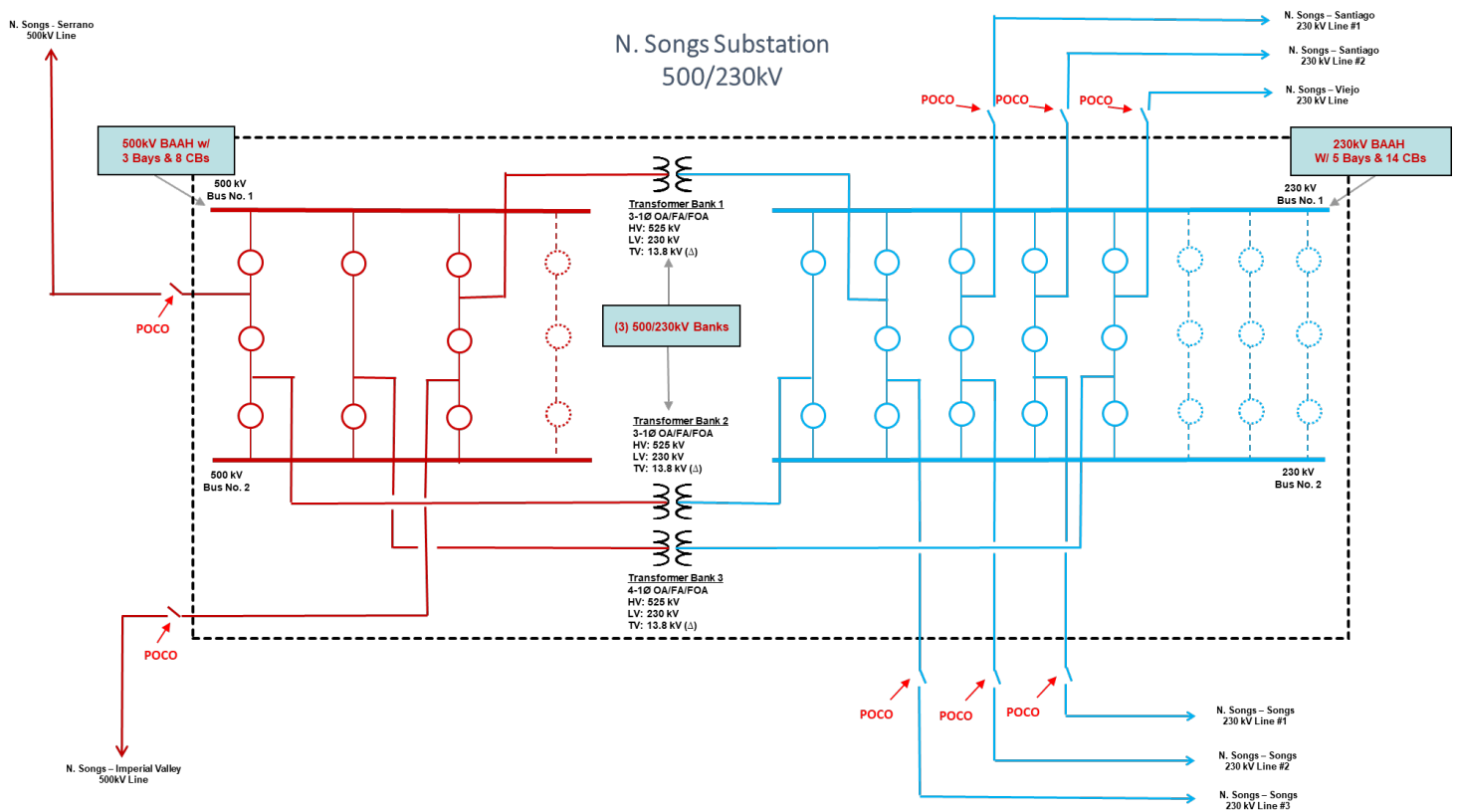
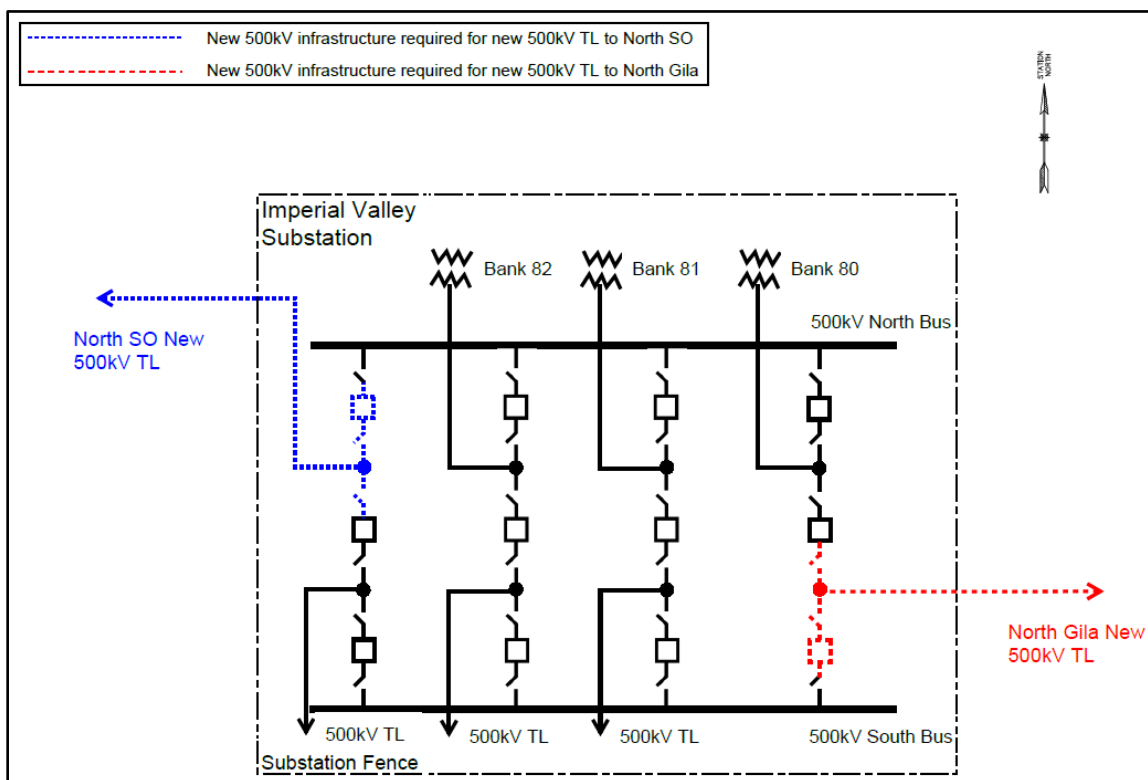

Figure I.1-3 provides a high level diagram of line terminations and interconnection to the new North of SONGS and Imperial Valley 500/230 kV substations.

Figure I.1-3: Interconnection to Imperial Valley 500 kV Substations



The facilities in the Imperial Valley – North of SONGS 500 kV Line and 500/230 kV Substation project that are eligible for competitive solicitation are

- The new 500/230 kV North of SONGS substation with the 500 kV and 230 kV bus-work and termination equipment at North of SONGS Substation
- The 500/230 kV transformers at North of SONGS Substation
- The new 145-mile 500 kV line from Imperial Valley to North of SONGS Substation
- The interconnection of the existing San Onofre – Santiago 230 kV 1 and 2 lines and the San Onofre – Viejo 230 kV line into the North of SONGS Substation
- The 500 kV series capacitors located along the line, and a line reactor at North of SONGS substation on Imperial Valley – North of SONGS transmission line

For the interconnection of the existing San Onofre – Santiago 230 kV 1 and 2 lines and the San Onofre – Viejo 230 kV line, the incumbent PTO (SCE) will be responsible for bringing the new transmission lines extensions up to a point within 100 feet of the new substation fence. The new line extensions will terminate on a dead end structure(s), to be owned by the SCE. The approved project sponsor will be responsible for (and will own and maintain) the facilities from this last dead end structure(s) into the North of SONGS Substation. The cost estimate for the SCE's scope of work depends on the distance of the interconnection point to the existing San Onofre – Santiago 230 kV 1 and 2 lines and the San Onofre – Viejo 230 kV line. The cost estimate for the line extensions is \$3.0M per mile per circuit.

For the interconnection of the new Imperial Valley – North of SONGS 500 kV Line, the incumbent PTO (SDG&E) will be responsible for installing the new transmission line segment from the Imperial Valley 500 kV bus up to a point within 100 feet of the Imperial Valley substation property line. These new line segments will terminate on a dead end structure(s), to be owned by SDG&E. The approved project sponsor will be responsible for (and will own and maintain) the facilities from this last dead end structure(s) back to the North of SONGS Substation.

The approved project sponsor, who will own the North of SONGS substation, will be responsible for owning, operating and maintaining the protection equipment located within the substation that is designated for the protection of the incoming transmission lines.

The approved project sponsor will coordinate with SCE and SDG&E regarding the specifications and the details of the associated line protection (e.g. current differential, directional comparison) etc. and will work with SCE and SDG&E to develop relay logic and detailed relay settings.

As the project includes building new transmission facility with voltage level over 200 kV, the approved project sponsor will be responsible for completing the WECC Progress Report and other processes required for this project.

I.2.2 Functional Specification for Imperial Valley – North of SONGS 500 kV Line and 500/230 kV Substation Project

North of SONGS Substation:

Nominal Phase to Phase Voltage: 525/230 kV

500 kV and 230 kV Initial Bus Configuration: Breaker and a half (BAAH)

500 kV and 230 kV Ultimate Bus Configuration: BAAH

Initial Number of 500 kV Lines and transformers: 5

Ultimate Number of 500 kV Lines and transformers: 8

Initial Number of 500 kV CBs: 8

Ultimate Number of 500 kV CBs: 12

Initial Number of 230 kV Lines and transformers: 9

Ultimate Number of 230 kV Lines and transformers: 16

Initial Number of 230 kV CBs: 14

Ultimate Number of 230 kV CBs: 24

Initial Minimum 500 kV Continuous Bus Ampacity: 5400A Ultimate Bus Ampacity:
5400A

Initial Minimum 4 hour 500 kV Bus Ampacity: 7350A Ultimate Bus Ampacity:
7350A

Initial Minimum Continuous 230 kV Bus Ampacity: 5400A Ultimate Bus Ampacity:
5400A

Initial Minimum 4 hour 230 kV Bus Ampacity: 7350A Ultimate Bus Ampacity:
7350A

Minimum 500 kV CB Continuous Ampacity: 4000A Minimum CB Interrupting Capability:
63 kA

Minimum 500 kV CB 4 hour Ampacity: 4480A Minimum CB Interrupting Capability:

Minimum 230 kV CB Continuous Ampacity: 4000A Minimum CB Interrupting Capability:
80 kA

Minimum 230 kV CB 4 hour Ampacity: 4480A Minimum CB Interrupting Capability:

Transfer Bus Required (SBSB only): N/A

Station Minimum BIL: 900 kV for 230 kV and 1800 kV for 500 kV

Initial Reactive Power Requirements: None

Ultimate Reactive Power Requirements: None

Telemetry Requirements: Install necessary equipment, including RTUs to monitor the typical bulk power elements such as MW, MVAR, and phase currents (Amps) at each line and also voltages (kV) at lines and buses and all circuit breaker (CB) status/control, protection relays statuses and alarms. The installed equipment must be capable of transmitting information to the appropriate Control Center.

Requested In Service Date: The requested in-service date is by 2030 but not later than June 1st 2034.

Low Profile Required: Subject to local permitting requirements

Gas Insulation Required: No, but if proposed shall be enclosed

Initial Number of Transformers: Three 3-phase banks with an installed spare, single phase units are permissible with one single phase spare

Ultimate Number of Transformers: Four 3-phase banks with an installed spare, single phase units are permissible with one single phase spare

Transformer Nominal Low Winding Phase to Phase Voltage: 230 kV

Tertiary Winding Required: Yes No Nominal Voltage Rating: kV

Initial Tertiary Winding Shunt Reactors: None

Ultimate Tertiary Winding Shunt Reactors: Up to (4) 45 MVAR shunt reactors

Primary Voltage Winding (wye, grounded wye, delta, etc): Grounded Wye

Secondary Voltage Winding: Grounded Wye; Tertiary Voltage Winding: Corner Grounded Delta

Maximum Transformer % IZ: Minimum Transformer % IZ:

Minimum Transformer Normal Rating: MVA Minimum Transformer 4-hour
Emergency Rating: MVA LTC Required:

No Load Taps Required: 5 NLTs with two 2.5% taps above & below nominal voltage of kV

CIP 14 requirement: The substation perimeter shall be fenced by a wall

Location of Series Compensation and Line Reactors : The project sponsor shall specify the location of the series compensation. The line reactors will be installed within the terminating substations. The cost of the series compensation is within the scope of this project and will be the responsibility of the approved project sponsor.

500 kV Transmission Line Functional Specifications

Overhead Line Construction

Line Terminus 1: Imperial Valley Substation 500 kV Bus

Line Terminus 2: North of SONGS Substation 500 kV Bus

Nominal Phase to Phase Voltage: 525 kV

Minimum Line Continuous Ampacity - Summer: 3800 Amps

Minimum Line Continuous Ampacity – Winter: 3800 Amps

Minimum Line 4 Hour Emergency Ampacity – Summer: 4408 Amps

Minimum Line 4 Hour Emergency Ampacity – Winter: 4408 Amps

Minimum Line 30 Minute Emergency Ampacity: 5130 Amps

Minimum Line 4 Hour Emergency Ampacity – Winter: 4408 Amps

Minimum Series Capacitor Continuous Ampacity - Summer: 3800 Amps

Minimum Series Capacitor Continuous Ampacity – Winter: 3800 Amps

Minimum Series Capacitor 4 Hour Continuous Ampacity - Summer: 4408 Amps

Minimum Series Capacitor 4 Hour Continuous Ampacity – Winter: 4408 Amps

Minimum Series Capacitor 30 Minute Emergency Ampacity: 5130 Amps

Approximate Line Impedance including the series compensation: $0.001523 + j0.02088$ pu (100 MVA base), plus/minus 5 percent.

Approximate level of series compensation required: 50% Approximate Line Length: 145 miles

Requested In Service Date: June 1, 2034

Support Structures: Single circuit structure

Shield Wire Required: Optical ground wire (minimum 24 pairs of fibers)

Failure Containment Loading Mitigation (anti-cascade structures, etc.): Per applicable codes

Shield Wire Ground Fault Withstand Ampacity: Coordinate with interconnecting entities

Aeolian Vibration Control (Conductor and Shield Wire): Vibration dampers must be installed on all conductors and overhead shield wires, with the exception of slack spans.

Transmission Line Minimum BIL: 1800 kV for 500 kV and 900 kV for 230 kV, with solidly grounded systems

Minimum ROW Width: Per applicable codes

Governing Design and Construction Standards: (GO 95, Known Local Conditions to be compliant with GO 95's High Fire-Threat District maps, facilities that traverse the HFTD will

require a Wildfire Mitigation Plan under PUC code 8386, NESC Code, applicable municipal codes)

Design Temperature: 50°C

I.2 Description and Functional Specifications of Proposed Policy-Driven North of SONGS – Serrano 500 kV Line Project

I.2.1 Description

In the 2022-2023 Transmission Plan, the ISO has identified a policy-driven need for the North of SONGS – Serrano 500 kV Line project as part of the Southern Area Reinforcement Projects. Figure I.2-1. provides a schematic diagram of the transmission system in the area. As shown in the figure, the project scope includes the new North of SONGS – Serrano 500 kV line, estimated at 30 miles.

Figure I.2-1: Schematic Diagram of the North of SONGS – Serrano 500 kV Line Project

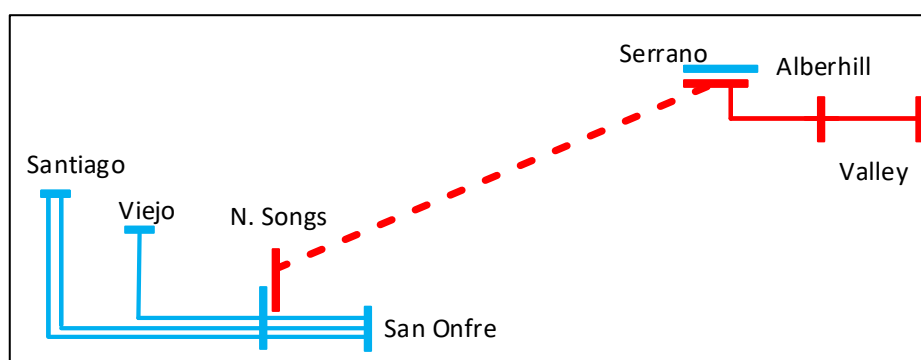

The ISO estimates that the proposed project will approximately cost \$503 million including both the competitive solicitation and directly assigned components. The ISO recognizes there may be some uncertainty regarding routing and siting of the 500 kV AC transmission line during the siting and permitting process for this project. As such, the ISO will seek cost and risk mitigation strategies from project sponsors' in their bid applications in the competitive solicitation process along with potential alternatives and mitigation measures if significant undergrounding of the line is required. The project need date is 2033 and the expected in-service date is 2034. The requested in-service date for the project is by 2033 but not later than June 1st 2034. Figure I.2-2 (below) provides a high level diagram of line terminations and interconnection to the Serrano 500/230 kV substation, and Figure I.1-2 (in the previous section above) provides a high level diagram of line terminations and interconnection to the new North of SONGS substation.

Figure I.2-2: Interconnection to Serrano 500 kV Substations

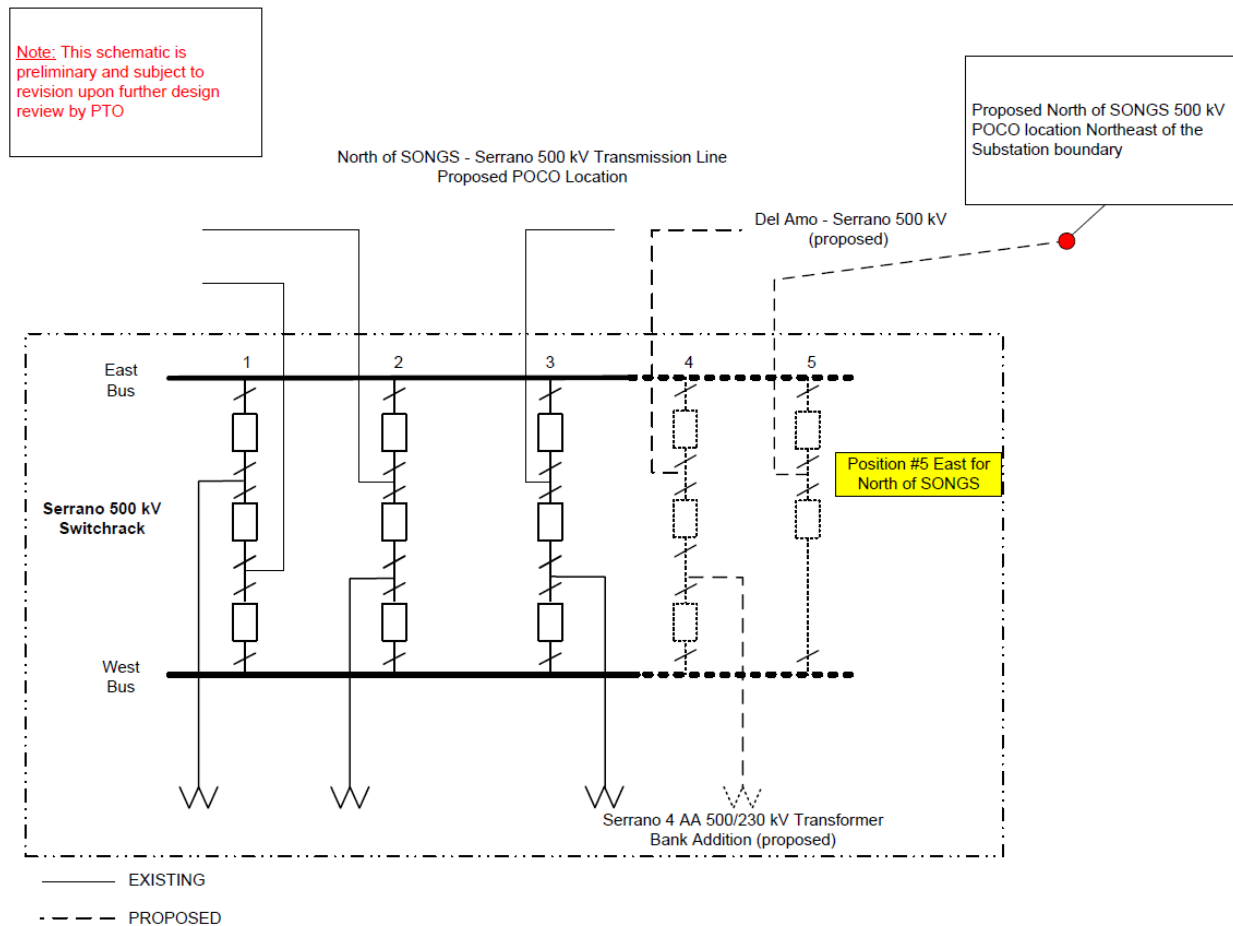

The facilities in the North of SONGS – Serrano 500 kV Line project that are eligible for competitive solicitation is the new 30-mile 500 kV line from North of SONGS to Serrano Substation.

For the interconnection of the new North of SONGS – Serrano 500 kV Line, the incumbent PTO (SCE) will be responsible for installing the new transmission line segments from the Serrano 500 kV bus up to a point within 100 feet of the Serrano substation property line. These new line segments will terminate on a dead end structure(s), to be owned by SCE. The approved project sponsor will be responsible for (and will own and maintain) the facilities from this last dead end structure(s) back to the North of SONGS Substation.

For the interconnection of the new North of SONGS – Serrano 500 kV Line, the project sponsor for the Imperial Valley – North of SONGS 500 kV Line and 500/230 kV Substation Project will be responsible for installing the new transmission line segments from the new North of SONGS 500 kV bus up to a point within 100 feet of the North of SONGS substation property line. These new line segments will terminate on a dead end structure(s), to be owned by the project sponsor for the Imperial Valley – North of SONGS 500 kV Line and 500/230 kV Substation Project. The

approved project sponsor will be responsible for (and will own and maintain) the facilities from this last dead end structure(s) back to the Serrano Substation.

The approved project sponsor will coordinate with SCE and the project sponsor for the Imperial Valley – North of SONGS 500 kV Line and 500/230 kV Substation Project regarding the specifications and the details of the associated line protection (e.g. current differential, directional comparison) etc. and will work with SCE and the project sponsor for the Imperial Valley – North of SONGS 500 kV Line and 500/230 kV Substation Project to develop relay logic and detailed relay settings.

As the project includes building new transmission facility with voltage level over 200 kV, the approved project sponsor will be responsible for completing the WECC Progress Report and other processes required for this project.

12.1 Functional Specification for North of SONGS – Serrano 500 kV Line Project

500 kV Transmission Line Functional Specifications

Overhead Line Construction

Line Terminus 1: North of SONGS Substation 500 kV Bus

Line Terminus 2: Serrano Substation 500 kV Bus

Nominal Phase to Phase Voltage: 525 kV

Minimum Line Continuous Ampacity - Summer: 3800 Amps

Minimum Line Continuous Ampacity – Winter: 3800 Amps

Minimum Line 4 Hour Emergency Ampacity – Summer: 4408 Amps

Minimum Line 4 Hour Emergency Ampacity – Winter: 4408 Amps

Minimum Line 30 Minute Emergency Ampacity: 5130 Amps

Approximate Line Impedance: $0.000315 + j0.008640$ pu (100 MVA base), plus/minus 5 percent

Approximate Line Length: 30 miles

Requested Service Date: The requested in-service date for the project is by 2033 but not later than June 1st 2034.

Support Structures: Single circuit structure

Shield Wire Required: Optical ground wire (minimum 6 pairs of fibers)

Failure Containment Loading Mitigation (anti-cascade structures, etc.): Per applicable codes

Shield Wire Ground Fault Withstand Ampacity: Coordinate with interconnecting entities

Aeolian Vibration Control (Conductor and Shield Wire): Vibration dampers must be installed on all conductors and overhead shield wires, with the exception of slack spans.

Transmission Line Minimum BIL: 1800 kV with solidly grounded systems

Minimum ROW Width: Per applicable codes

Governing Design and Construction Standards: (GO 95, Known Local Conditions to be compliant with GO 95's High Fire-Threat District maps, facilities that traverse the HFTD will require a Wildfire Mitigation Plan under PUC code 8386, NESC Code, applicable municipal codes)

Design Temperature: 50°C

I.3 Description and Functional Specifications of Proposed Policy-Driven North Gila – Imperial Valley #2 500 kV Line Project

I.3.1 Description

In the 2022-2023 Transmission Plan, the ISO has identified a policy-driven need for the North Gila – Imperial Valley #2 500 kV Line Project as part of the Southern Area Reinforcement Projects. Figure I.3-1 provides a schematic diagram of the transmission system in the area. As shown in the figure, the project scope includes a new 500 kV circuit between North Gila and Imperial Valley substations, estimated at 85 miles.

Figure I.3-1: Location of North Gila – Imperial Valley #2 500 kV Line Project

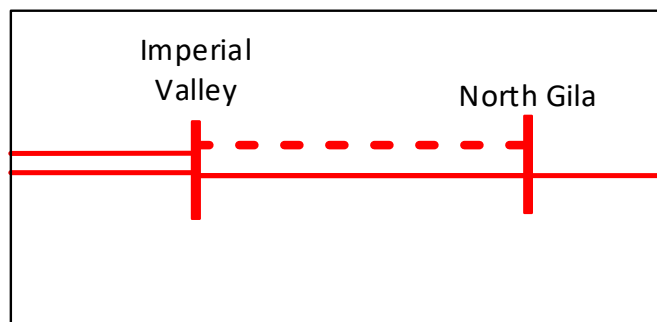

The ISO estimates that the proposed project, including both the competitive and directly assigned components, will approximately cost \$340 million. The requested in-service date for the project is June 1st 2028. Figure I.3-2 provides a schematic diagram of the interconnection to North Gila and Imperial Valley 500 kV substations.

Figure I.3-2: Interconnection to North Gila 500 kV and Imperial Valley 500 kV

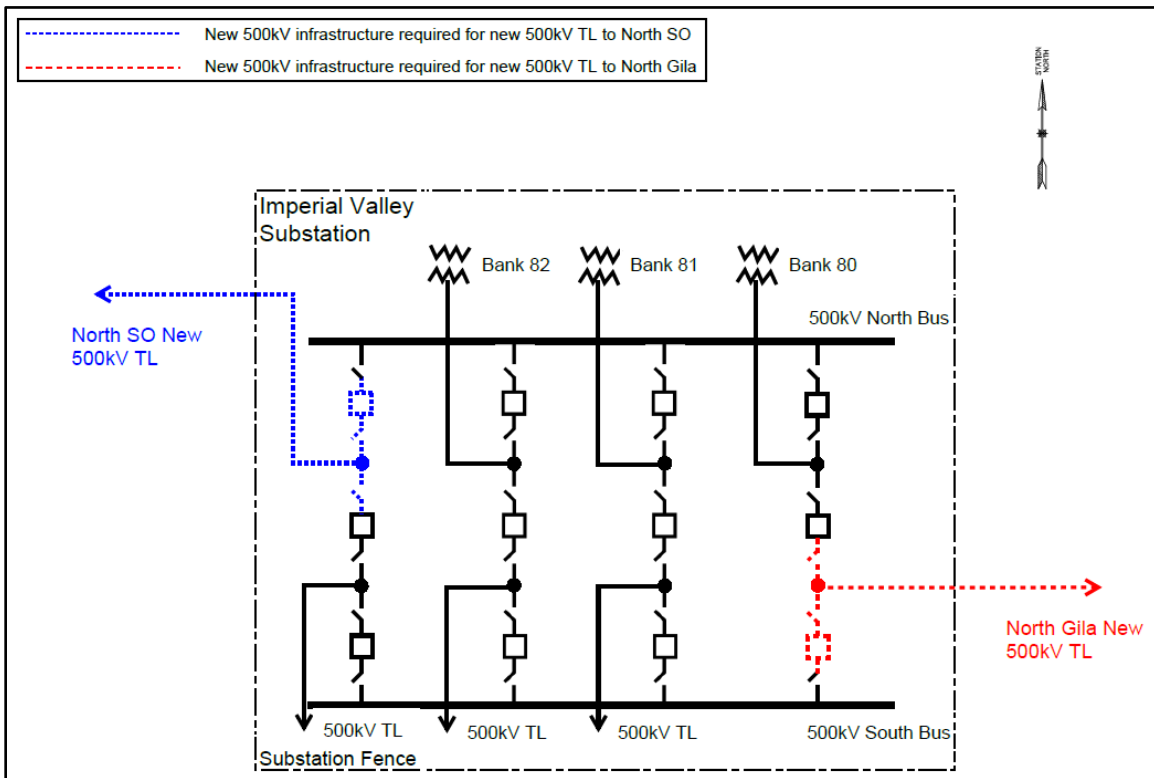

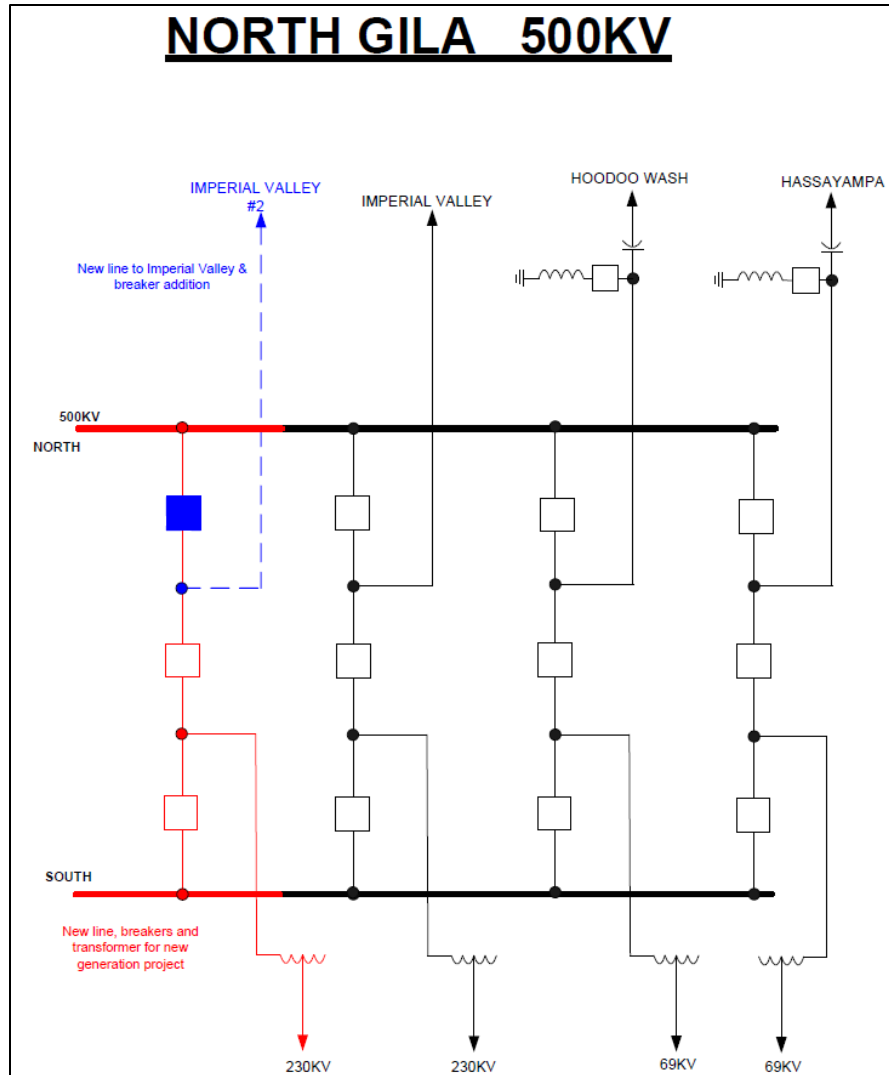

The facilities in the North Gila – Imperial Valley #2 500 kV Line project that are eligible for competitive solicitation is the new 500 kV line from North Gilla to Imperial Valley substation.

For the interconnection of the North Gila – Imperial Valley #2 500 kV Line to the Imperial Valley substation, the incumbent PTO (SDG&E) will be responsible for installing the new transmission line segments from the Imperial Valley 500 kV bus up to a point within 100 feet of the Imperial Valley substation property line. This new line segments will terminate on a dead end structure(s), to be owned by the incombant PTO (SDG&E). The approved project sponsor will be responsible for (and will own and maintain) the facilities from this last dead end structure(s) back to the North Gila Substation.

For the interconnection of the North Gila – Imperial Valley #2 500 kV Line to the Imperial Valley substation, the incumbent PTO (SDG&E) will be responsible for installing the new transmission

line segments from the Imperial Valley 500 kV bus up to a point within 100 feet of the Imperial Valley substation property line and line shunt reactors. This new line segments will terminate on a dead end structure(s), to be owned by the incumbent PTO (SDG&E). The approved project sponsor will be responsible for (and will own and maintain) the facilities from this last dead end structure(s) back to the North Gila Substation.

For the interconnection of the North Gila – Imperial Valley #2 500 kV Line to the North Gila substation, APS¹ will be responsible for installing the new transmission line segments from the North Gila 500 kV bus up to a point within 100 feet of the North Gila substation property line and line shunt reactors. This new line segments will terminate on a dead end structure(s), to be owned by the incumbent PTO (SDG&E). The approved project sponsor will be responsible for (and will own and maintain) the facilities from this last dead end structure(s) back to the Imperial Valley substation.

The approved project sponsor will coordinate with SDG&E and APS for the specifications and the details of the associated line protection (e.g. current differential, directional comparison) etc. to develop relay logic and detailed relay settings.

As the project includes building new transmission facility with voltage level over 200 kV, the approved project sponsor will be responsible for completing the WECC Progress Report and other processes required for this project.

¹ APS is the entity responsible for planning, designing, constructing and maintaining the North Gila substation per the Arizona Transmission System Participation Agreement (ATSPA)

I3.2 Functional Specification for North Gila – Imperial Valley #2 500 kV Line Project

500 kV Transmission Line Functional Specifications

Overhead Line Construction

Line Terminus 1: North Gila Substation 500 kV Bus

Line Terminus 2: Imperial Valley Substation 500 kV Bus

Nominal Phase to Phase Voltage: 525 kV

Minimum Line Continuous Ampacity - Summer: 2857 Amps

Minimum Line Continuous Ampacity – Winter: 2857 Amps

Minimum Line 4 Hour Emergency Ampacity – Summer: 2857 Amps

Minimum Line 4 Hour Emergency Ampacity – Winter: 2857 Amps

Approximate Line Impedance: 0.000893 + 0.024480 pu (100 MVA base), plus/minus 5 percent.

Approximate Line Length: 81 miles

Requested In Service Date: June 1, 2032

Support Structures: Single circuit structure

Shield Wire Required: Optical ground wire (minimum 24 pairs of fibers)

Failure Containment Loading Mitigation (anti-cascade structures, etc.): Per applicable codes

Shield Wire Ground Fault Withstand Ampacity: Coordinate with interconnecting entities

Aeolian Vibration Control (Conductor and Shield Wire): Vibration dampers must be installed on all conductors and overhead shield wires, with the exception of slack spans.

Transmission Line Minimum BIL: 1800 kV with solidly grounded systems

Minimum ROW Width: Per applicable codes

Governing Design and Construction Standards: (GO 95, NESC Code, applicable municipal codes)

Design Temperature: 50°C