



# 2023 & 2027 Draft LCR Study Results Stockton Area

Ebrahim Rahimi

Senior Advisor Regional Transmission Engineer

Stakeholder Call

March 9, 2022

# Stockton Area Transmission System & LCR Sub-areas

Tesla - Bellota

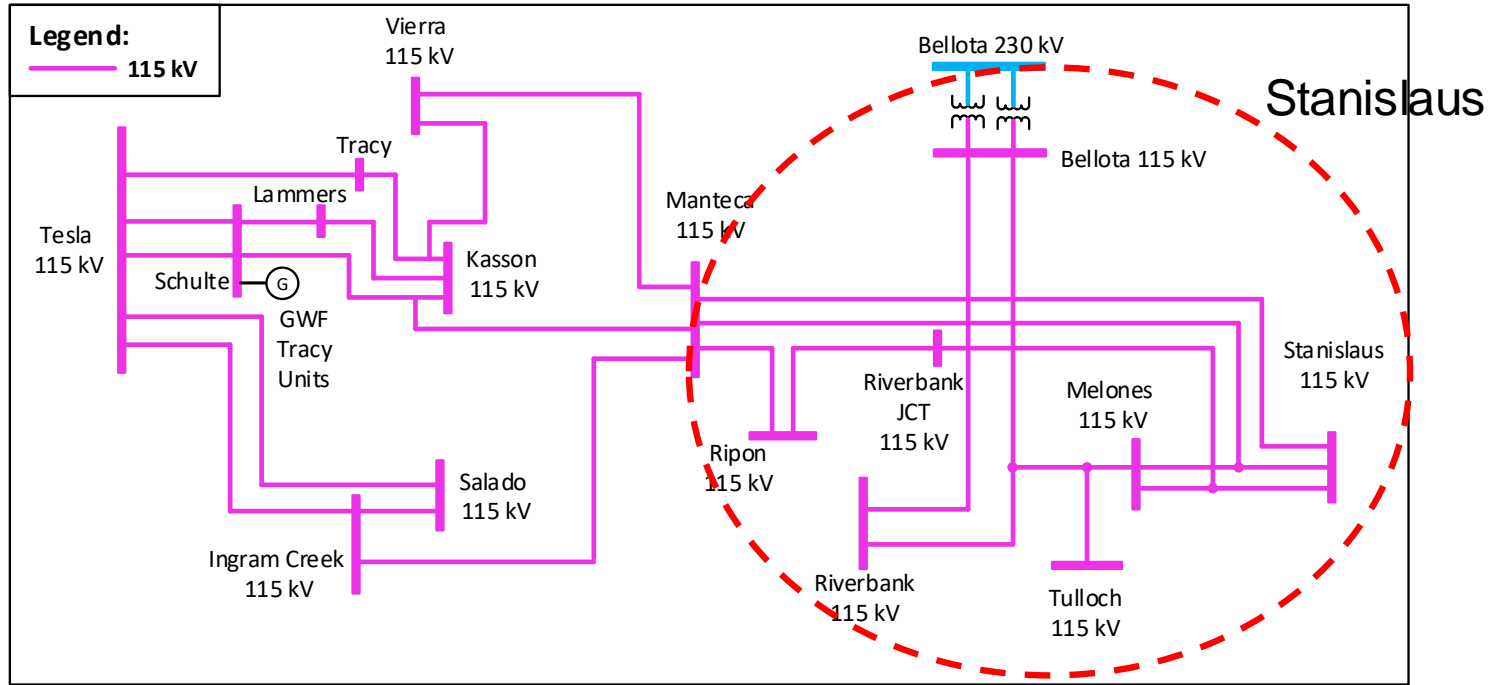

Lockeford

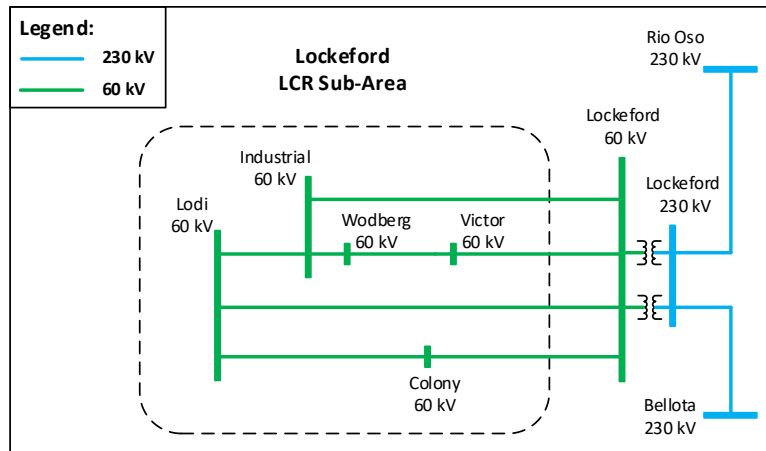

# New major transmission projects

Project Name	Expected ISD
Year 2023	
None	
Year 2027	
Lockeford – Lodi Area 230 kV Development	2027

# Power plant changes

## Additions:

- One new 10 MW battery

## Retirements:

- No new retirements

## Stockton Area Overall: Load and Resources

Load (MW)	2023	2027	Generation (MW)	2023	2027
Gross Load	1,078	1,134	Market/ Net Seller/ Battery	425	425
AAEE	-6	-9	Solar	12	12
Behind the meter DG	-4	0	Wind	0	0
<b>Net Load</b>	<b>1,069</b>	<b>1,125</b>	Muni	136	136
Transmission Losses	21	22	QF	0	0
Pumps	0	0	Future preferred resource and energy storage	0	0
<b>Load + Losses + Pumps</b>	<b>1,090</b>	<b>1,147</b>	<b>Total Qualifying Capacity</b>	<b>573</b>	<b>573</b>

# Lockeford Sub-Area : Requirements

Year	Category	Limiting Facility	Contingency	LCR (MW) (Deficiency)
2023	P3	Lockeford – Lodi #2 60 kV	Lockeford-Industrial 60 kV line and Lodi CT	27 (3)
2027	No LCR due to implementation of the Lockeford – Lodi 230 kV Area 230 kV Project			No requirements

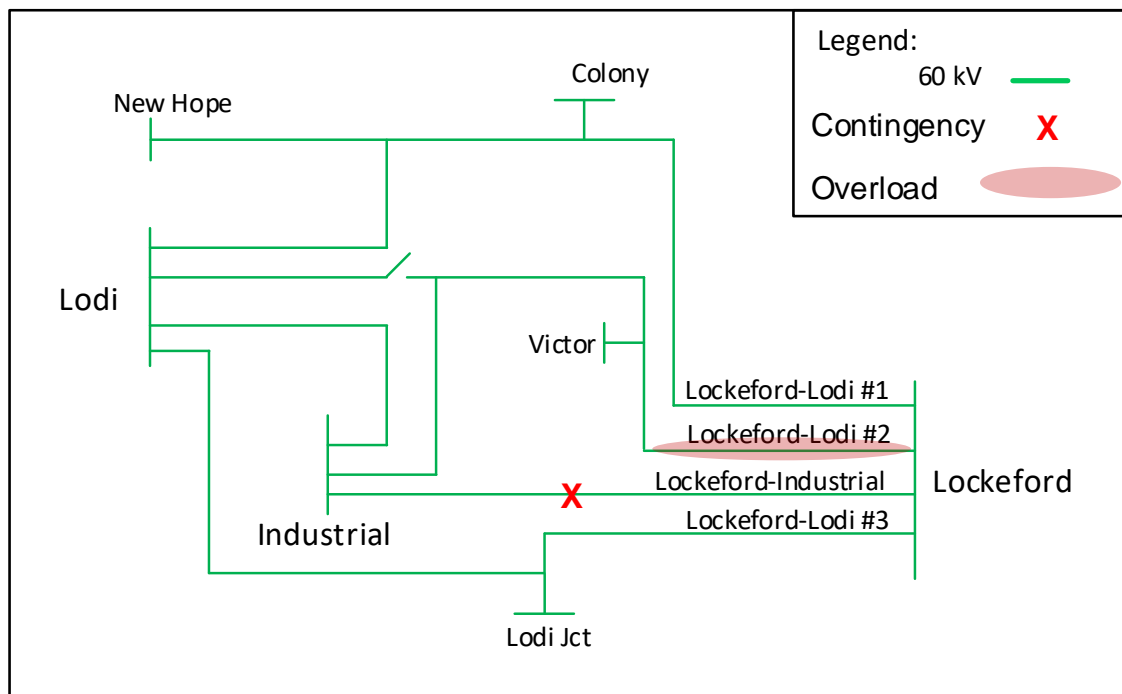

# Lockeford Sub-area: Load Profiles

Stockton - Lockeford LCR Subarea:  
 2027 projected pk day load profile & approx. LSC (trans + LCR Gen + ES)  
 Approx storage size that can be added to this area from charging restriction perspective =  
 27 MW and 108 MWh. Max 4-hr storage = 27 MW

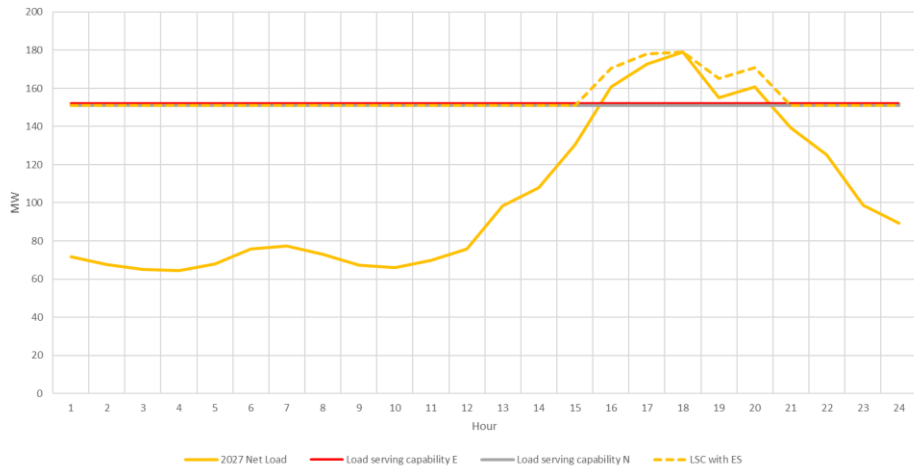

Stockton - Lockeford LCR Subarea:  
 2027 projected load profile & approx. load serving capability (transmission only)

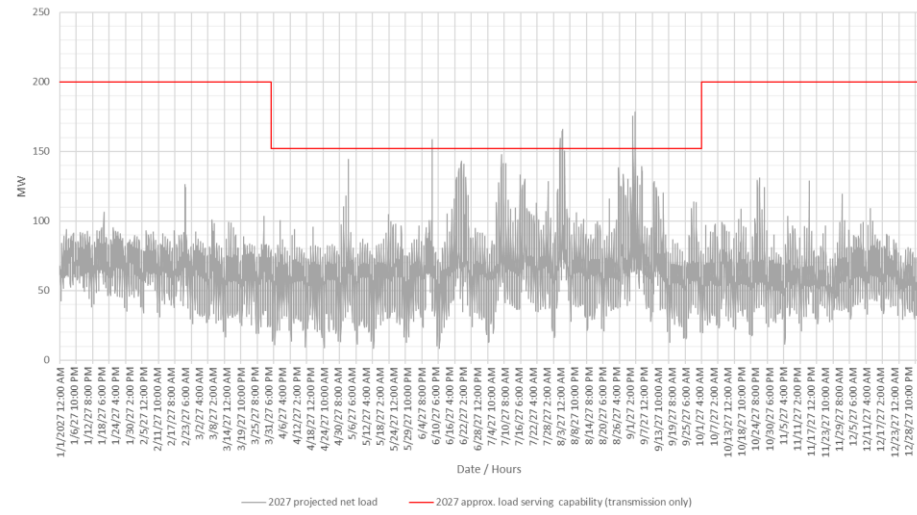

# Stanislaus Sub-Area : Requirements

Year	Category	Limiting Facility	Contingency	LCR (MW) (Deficiency)
2023	P3	Manteca - Ripon 115 kV Line	Bellota-Riverbank-Melones 115 kV line and Stanislaus PH unit	155
2027	P3	Manteca - Ripon 115 kV Line	Bellota-Riverbank-Melones 115 kV line and Stanislaus PH unit	177

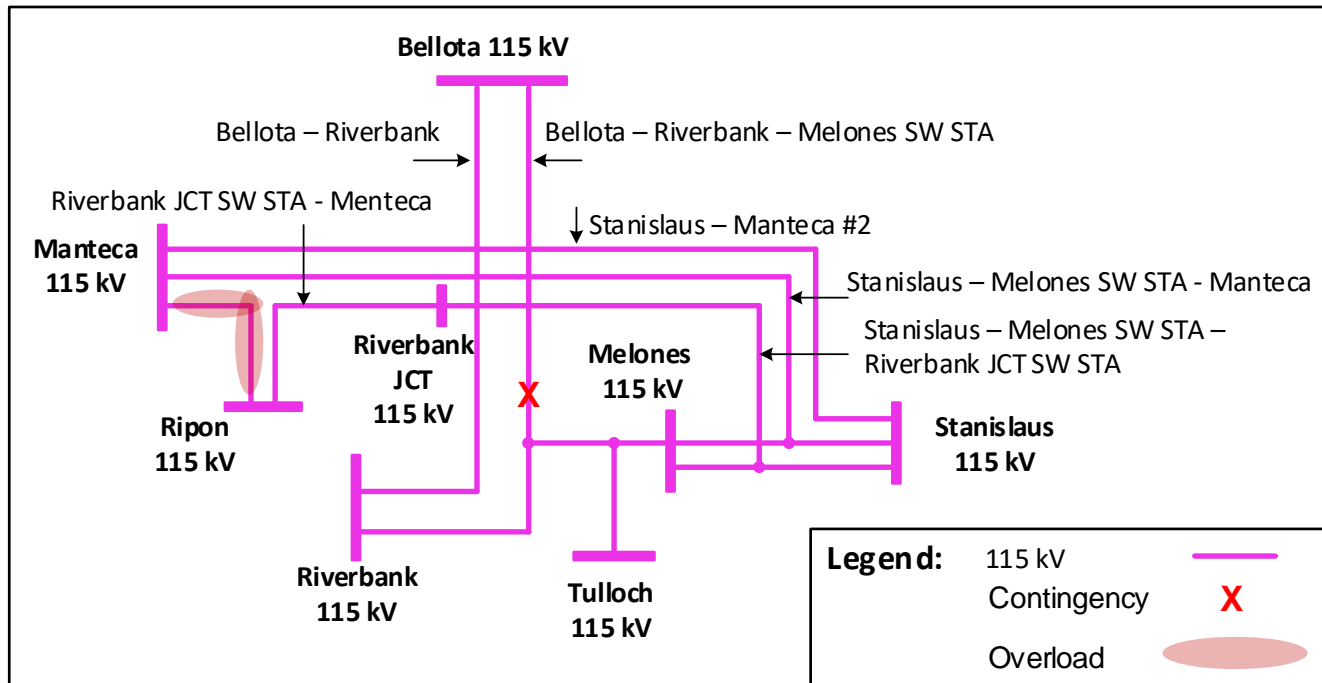



# Tesla - Bellota Sub-Area : Requirements (2023)

Year	Category	Limiting Facility	Contingency	LCR (MW) (Deficiency)
2023	P2-4	Stanislaus – Melones – Riverbank Jct line	Tesla 115 kV bus-tie breaker	668 (119 NQC / 131 Peak)
2023	P6	Schulte-Kasson- Manteca 115 kV line	Schulte – Lammers and Tesla – Tracy 115 kV lines	657 (416 NQC / 428 Peak)
Total LCR Need in 2023				965 (416 NQC / 428 Peak)

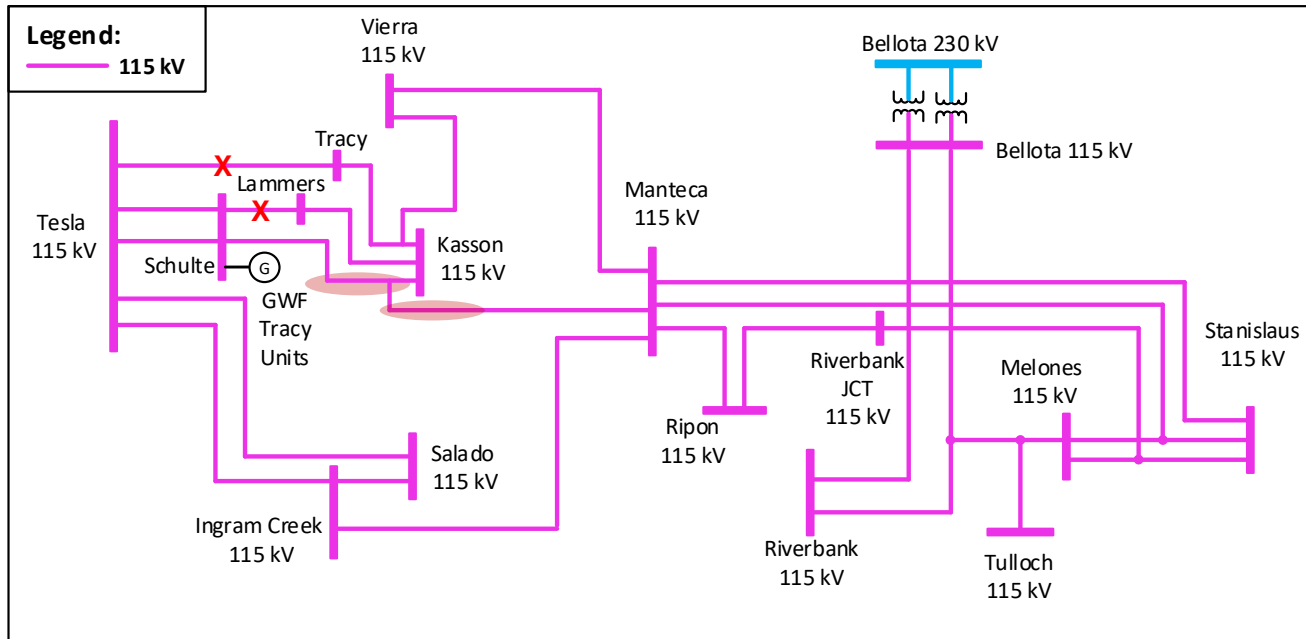

# Tesla - Bellota Sub-Area : Requirements (2027)

Year	Category	Limiting Facility	Contingency	LCR (MW) (Deficiency)
2027	P2-4	Stanislaus – Melones – Riverbank Jct line	Tesla 115 kV bus-tie breaker	667 (118 NQC / 130 Peak)
2027	P6	Schulte-Kasson- Manteca 115 kV line	Schulte – Lammers and Tesla – Tracy 115 kV lines	645 (404 NQC / 416 Peak)
Total LCR Need in 2027				953 (404 NQC / 416 Peak)

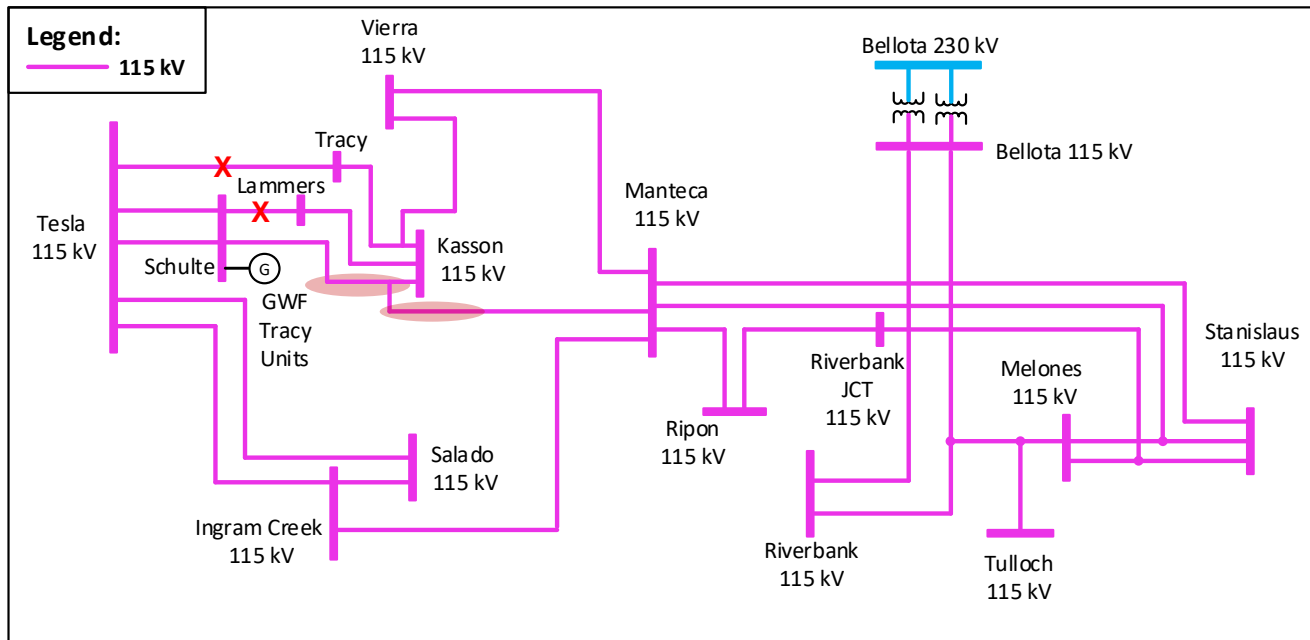

# Tesla - Bellota Sub-area: Load Profiles

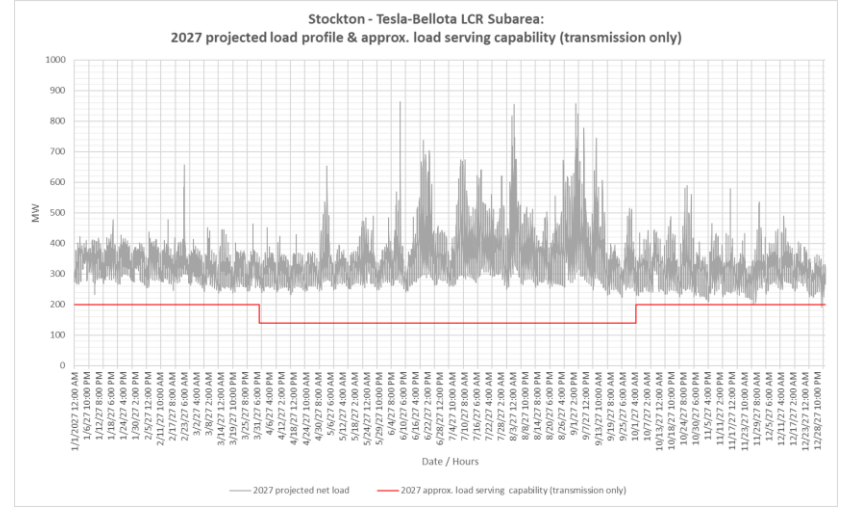
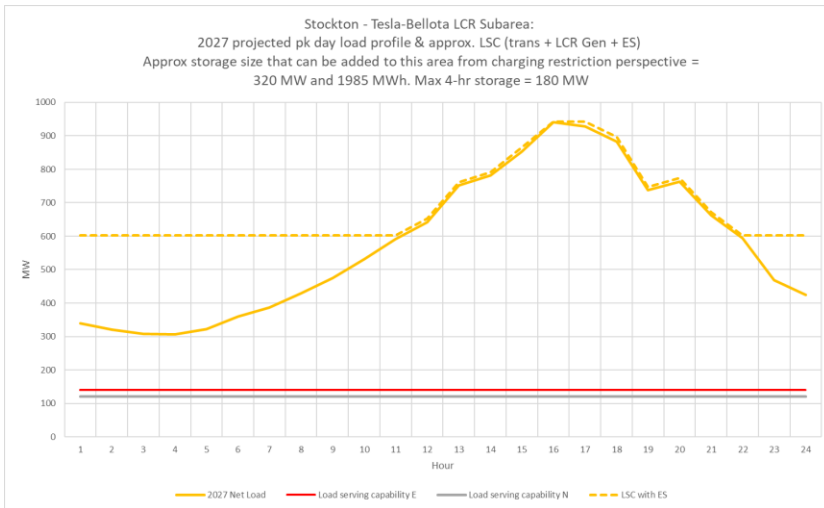
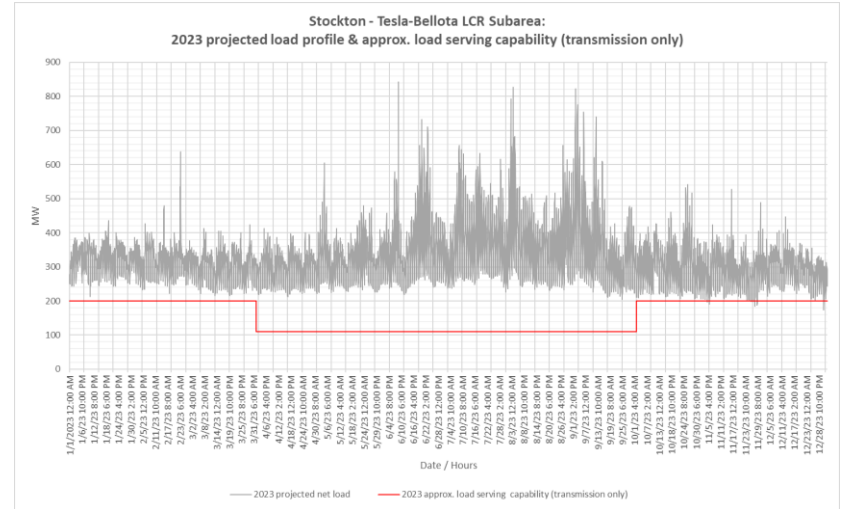
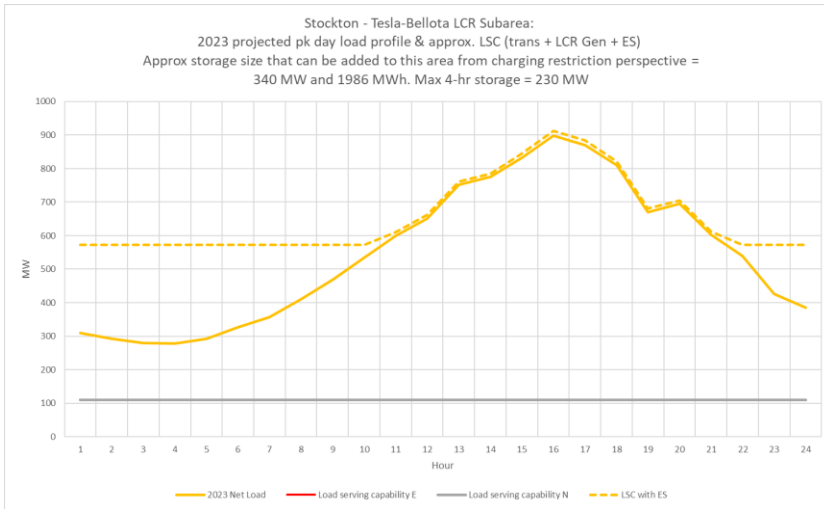

## Changes from 2022 to 2023

Sub-area	2022		2023	
	Load	LCR	Load	LCR
Lockeford	174	0	181	27
Stanislaus	N/A	196	N/A	155
Tesla - Bellota	853	1,373	909	965
Total	1,027	1,373	1,090	992

- The LCR increases in Lockeford sub-area is due to higher load forecast.
- Although load forecast in the Tesla – Bellota sub-area increased, the LCR requirement has decreased due to higher line rating.

*N/A=Flow-through area. No defined load pocket or not an LCR sub-area anymore*

## Changes from 2026 to 2027

Sub-area	2026		2027	
	Load	LCR	Load	LCR
Lockeford	180	27	196	0
Stanislaus	N/A	226	N/A	177
Tesla - Bellota	945	1,641	951	953
Total	1,125	1,668	1,147	953

- There is no LCR requirement in Lockeford sub-area after the implementation of the Lockeford – Lodi 230 kV Area 230 kV Project
- Although load forecast in the Tesla – Bellota sub-area slightly increased, the LCR requirement has decreased due to higher line rating.

*N/A=Flow-through area. No defined load pocket or not an LCR sub-area anymore*

## Stockton Area Total LCR Need

Study Year	Existing Generation Capacity Needed (MW)	NQC Deficiency (MW)	Total MW Need
2023	573	419	992
2027	549	404	953