



2025 & 2029 Draft LCR Study Results Stockton Area

Subrina Sultana Noureen

Regional Transmission Engineer

Stakeholder Call

March 6, 2024

New major transmission projects

Projects	Expected ISD
Mosher Transmission Project	December 2027
Vierra 115 kV Looping Project	May 2026
Tesla 230 kV Bus Series Reactor	March 2024
Lockeford-Lodi Area 230 kV Development	January 2029
Manteca #1 60 kV Line Section Reconductoring Project	February 2025
Manteca-Ripon-Riverbank-Melones Area 115 kV Line Reconductoring Project	May 2026
Weber-Mormon Jct Line Section Reconductoring Project	May 2026
Tesla 115 kV Bus Reconfiguration	December 2030
Banta 60 kV Bus Voltage Conversion	December 2024

Based on Transmission Development Forum October 2023 Meeting Update

Stockton Area Transmission System & LCR Sub-areas

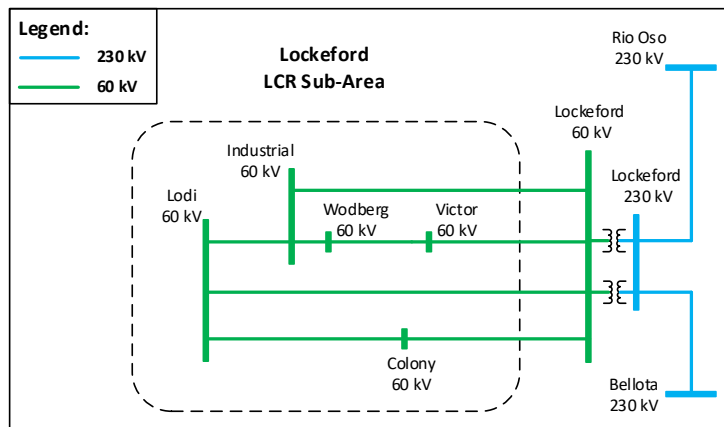
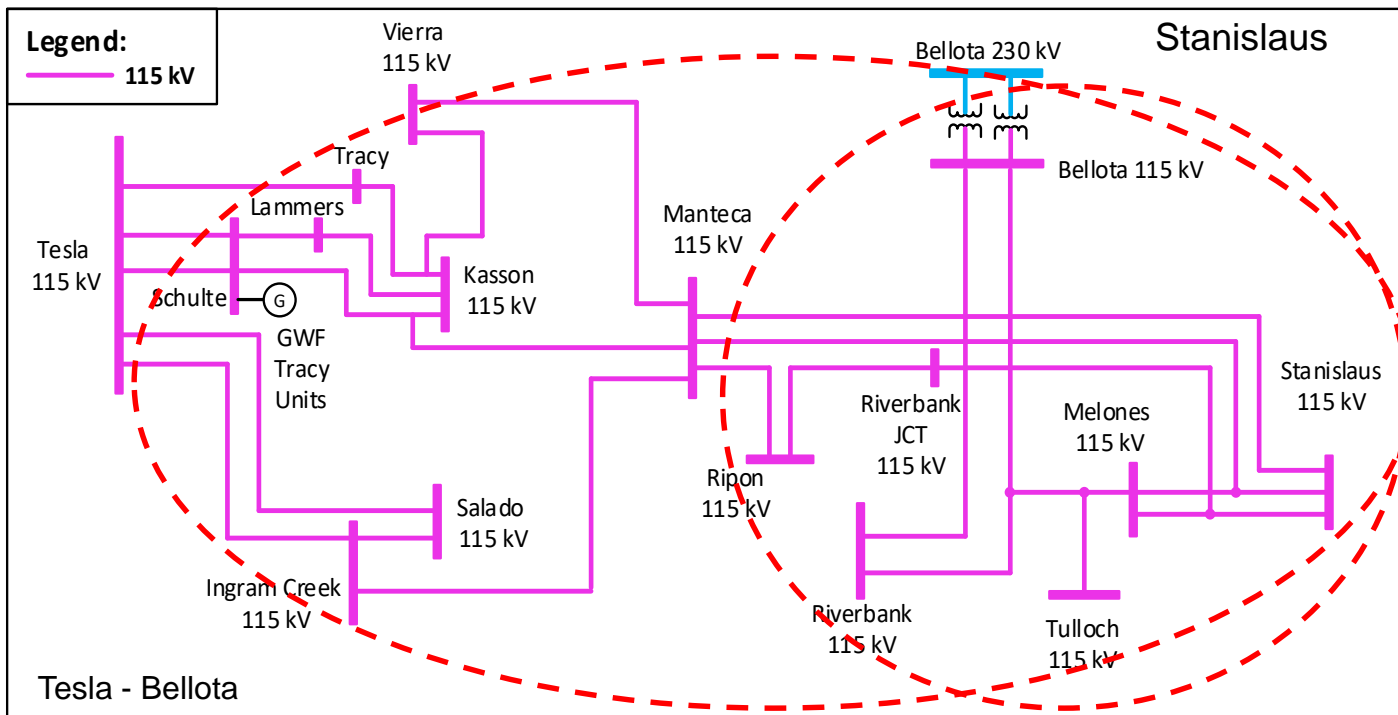

Stockton Area Overall: Load and Resources

Load (MW)	2025	2029	Generation (MW)	2025	2029
Gross Load	1116	921	Market/Net Seller	450	496
AAEE	-8	-14	Battery	152	152
Behind the meter DG	0	0	MUNI/QF	125	101
Net Load	1108	907	Solar	7	7
Transmission Losses	21	16	Existing 20-minute Demand Response	6	6
Pumps	0	0	Mothballed	0	0
Load + Losses + Pumps	1129	923	Total	740	762

Lockeford Sub-Area : Requirements

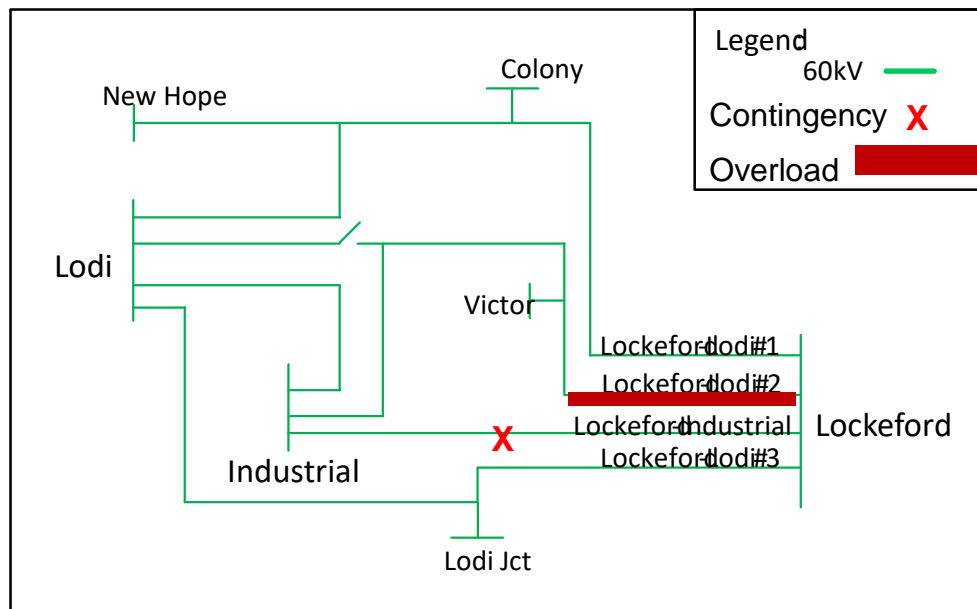

Year	Category	Limiting Facility	Contingency	LCR (MW) (Deficiency)
2025	P3	Lockeford – Lodi #2 60 kV	Lockeford-Industrial 60 kV line and Lodi CT	19 MW
2029	No LCR due to implementation of the Lockeford-Lodi Area 230 kV Development Project.			No requirements

There is no a LCR requirement in Lockeford sub-area for 2029 after the implementation of the Lockeford – Lodi 230 kV Area 230 kV Project.

Lockeford Sub-area: Load Profiles

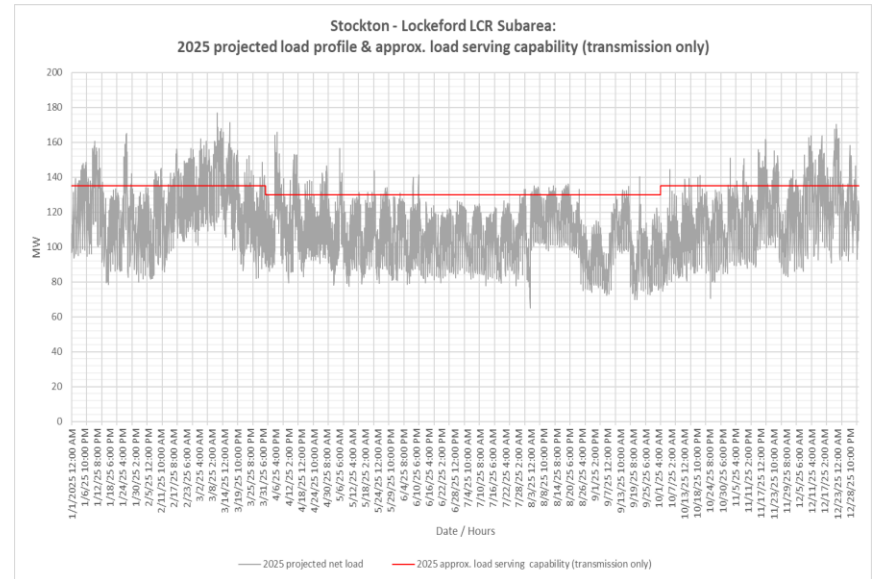
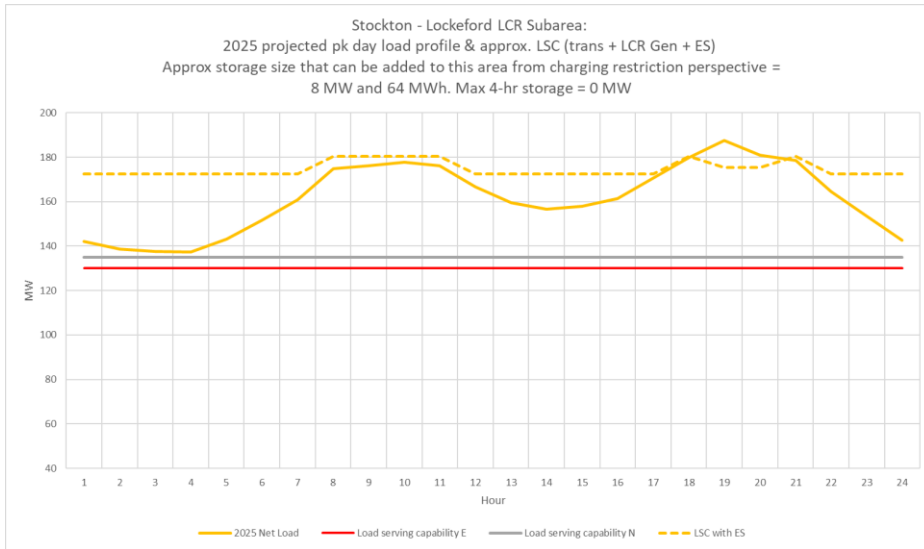

Stanislaus Sub-Area Requirements

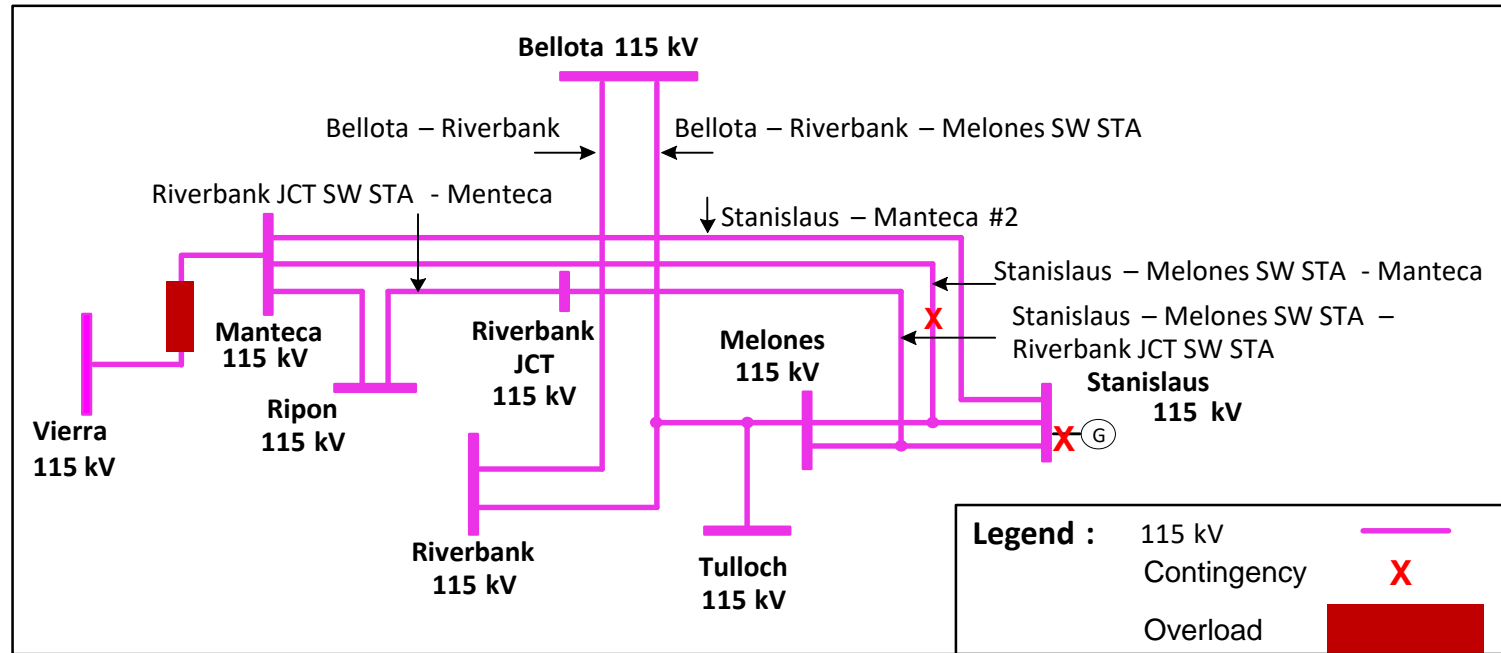

Year	Category	Limiting Facility	Contingency	LCR (MW) (Deficiency)
2025	P3	VIERRA 115 kV – MANTECA 115 kV	Bellota-Riverbank-Melones 115 kV line and Stanislaus PH unit	171 MW
2029	P3	VIERRA 115 kV – MANTECA 115 kV	Bellota-Riverbank-Melones 115 kV line and Stanislaus PH unit	169 MW

Tesla - Bellota Sub-Area Requirements

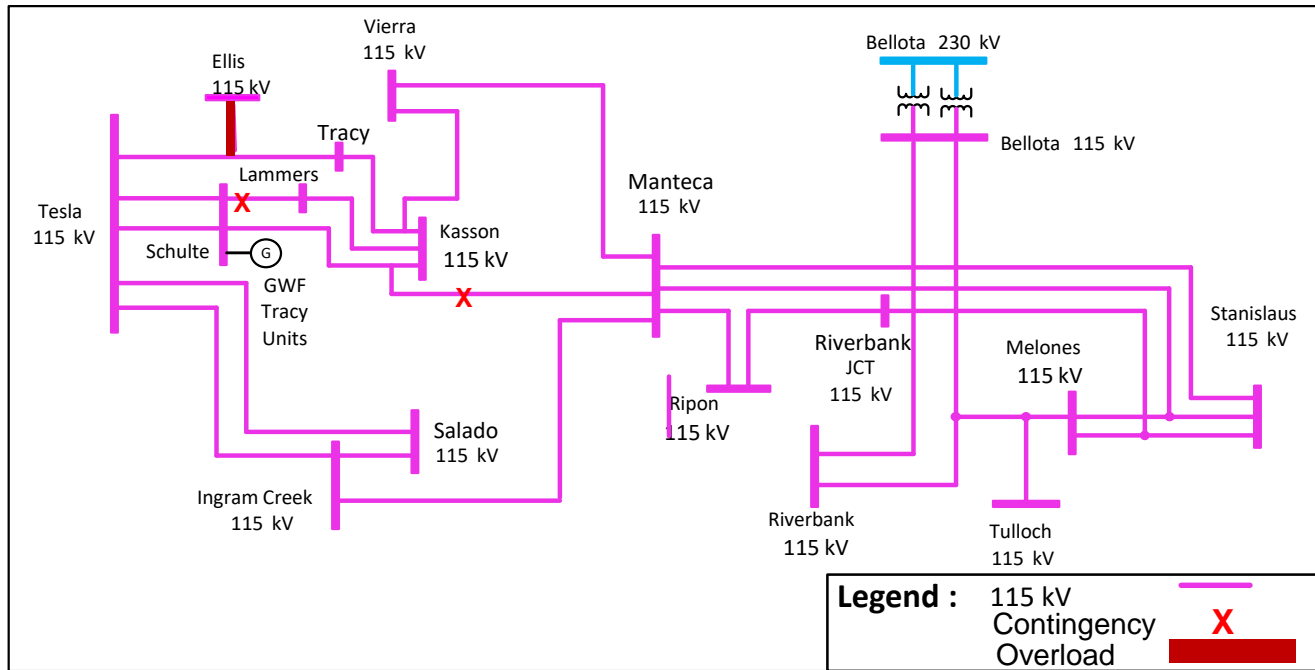

Year	Category	Limiting Facility	Contingency	LCR (MW) (Deficiency)
2025	P2-4	Melones–Riverbank-Bellota 115 kV	Tesla 115KV - Section 2D & 1D	665 MW (81)
2025	P6	Tesla – Tracy 115 kV	Schulte - Lammers 115 kV Line and Schulte - Kason - Manteca 115 kV Line	960 MW (580)
Total LCR Need in 2025				1296 MW (580)

Tesla - Bellota Sub-area: Load Profiles

In progress and will be provided with final LCR results.

Tesla - Bellota Sub-Area Requirements

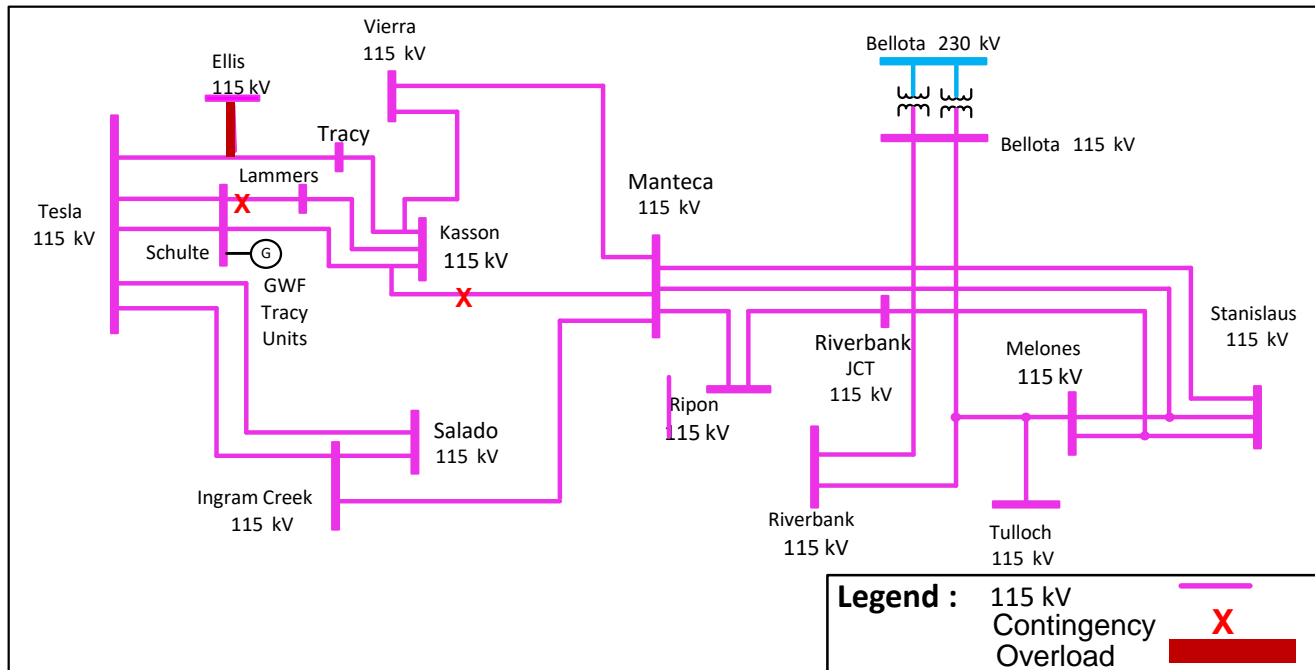

Year	Category	Limiting Facility	Contingency	LCR (MW) (Deficiency)
2029	P2-4	Melones–Riverbank- Bellota 115 kV	Tesla 115KV - Section 2D & 1D	690 (60)
2029	P6	Tesla – Tracy 115 kV	Schulte - Lammers 115 kV Line and Schulte - Kasson - Manteca 115 kV Line	655 (229)
Total LCR Need in 2029				991 (229)

Tesla - Bellota Sub-area: Load Profiles

In progress and will be provided with final LCR results.

Changes from 2024 to 2025

Sub-area	2024		2025	
	Load	LCR	Load	LCR
Lockeford	175	24	187	19
Stanislaus	N/A	177	N/A	171
Tesla - Bellota	888	1274 (548)	928	1296 (580)
Total	1063	1298 (548)	1115	1315 (580)

The load forecast has increased and the LCR need has increased as well.

- N/A=Flow-through area. No defined load pocket or not an LCR sub-area anymore

Changes from 2027 to 2028

Sub-area	2028		2029	
	Load	LCR	Load	LCR
Lockeford	N/A	N/A	N/A	N/A
Stanislaus	N/A	185	N/A	169
Tesla - Bellota	937	1054 (282)	923	911 (229)
Total	937	1054 (282)	923	911 (229)

- After the implementation of the Lockeford – Lodi 230 kV Area 230 kV Project in 2029, there is no longer a requirement for LCR in the Lockeford sub-area.
- The Vierra Loop-in project and Tesla 115 kV Bus upgrade will alleviate some of the LCR requirements in the Tesla-Bellota Area.
- The load forecast has slightly decreased and the LCR results have decreased as well.
- N/A=Flow-through area. No defined load pocket or not an LCR sub-area anymore

Stockton Area Total LCR Need

Study Year	Existing Generation Capacity Needed (MW)	NQC Deficiency (MW)	Total MW Need
2025	735	580	1315
2029	762	229	911