



2023 & 2027 Draft LCR Study Results San Diego Non-Bulk Sub-Areas

Rene Romo

Sr. Regional Transmission Engineer

Stakeholder Call

April 12, 2022

San Diego Area

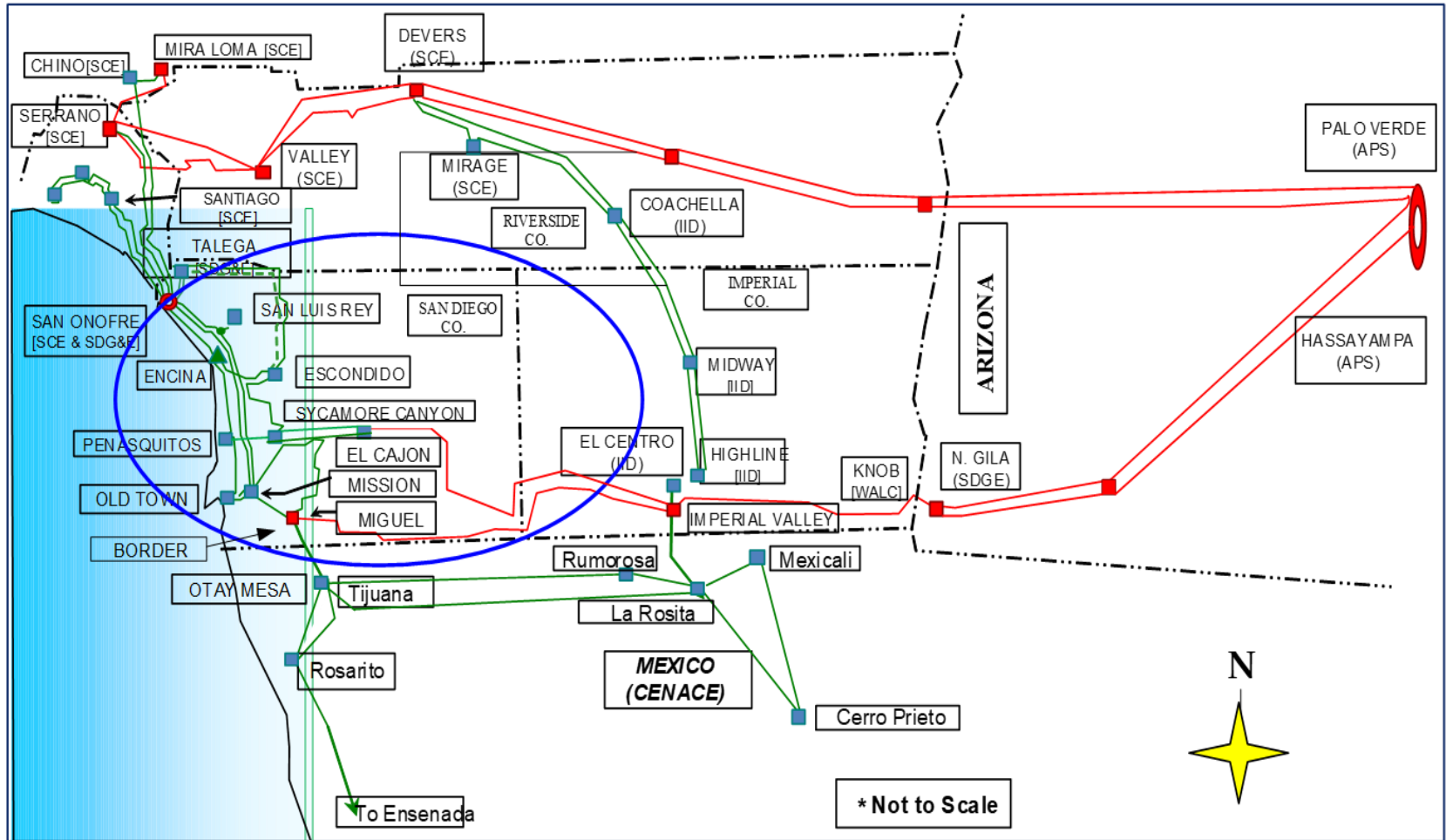

Major Network Upgrades Modeled in 2023

1. TL644, South Bay-Sweetwater: Reconductor
2. Artesian 230 kV expansion with 69 kV upgrade
3. 2nd San Marcos–Escondido 69 kV line
4. TL674A Loop-in (Del Mar-North City West) & Removal of TL666D (Del Mar-Del Mar Tap)
5. Reconductor TL692: Japanese Mesa - Las Pulgas
6. Rose Canyon-La Jolla 69 kV T/L upgrade
7. IID's S-Line upgrade

Additional Network Upgrades in 2027

1. South Orange County Reliability Enhancement
2. TL13834 Trabuco-Capistrano 138 kV line upgrade
3. Reconductor TL 605 Silvergate – Urban
4. TL695B Japanese Mesa-Talega Tap reconductor
5. Reconductor of Stuart Tap–Las Pulgas 69 kV line (TL690E)

Border Sub-area: Load and Resources

		2023	2027
Load (MW)	Gross Load	141	156
	AAEE	-1	-1
	Behind-The-Meter PV	0	0
	Net Load	140	155
	Transmission Loss	1	1
	Net Load + Loss	141	156
Resources (MW)	Gas-Fired	145	145
	Solar PV	0	0
	Wind	0	0
	QF/Other	0	0
	Demand Response	0	0
	Energy Storage	0	0

Border Sub-area: One-line diagram

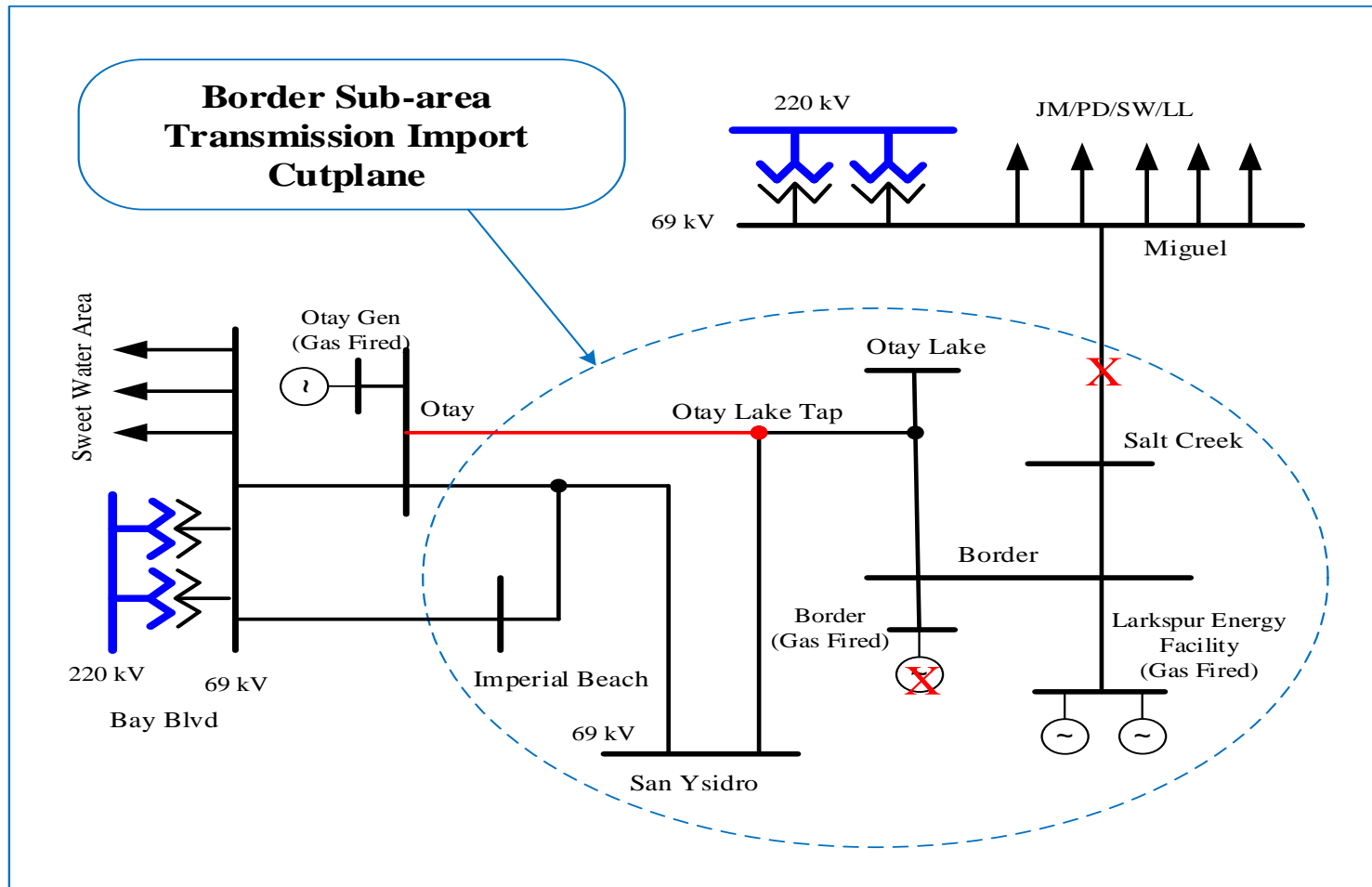

Border Sub-area: LCR Requirement

Year	Category	Contingency	Limiting Facility	LCR (MW)
2023	P3	Border unit out of service followed by the outage of Miguel-Salt Creek 69 kV #1 (TL6910)	Otay-Otay Lake Tap 69 kV (TL649)	69
2027	P3	Border unit out of service followed by the outage of Miguel-Salt Creek 69 kV #1 (TL6910)	Otay-Otay Lake Tap 69 kV (TL649)	80

Border Sub-area Load Profiles - 2023

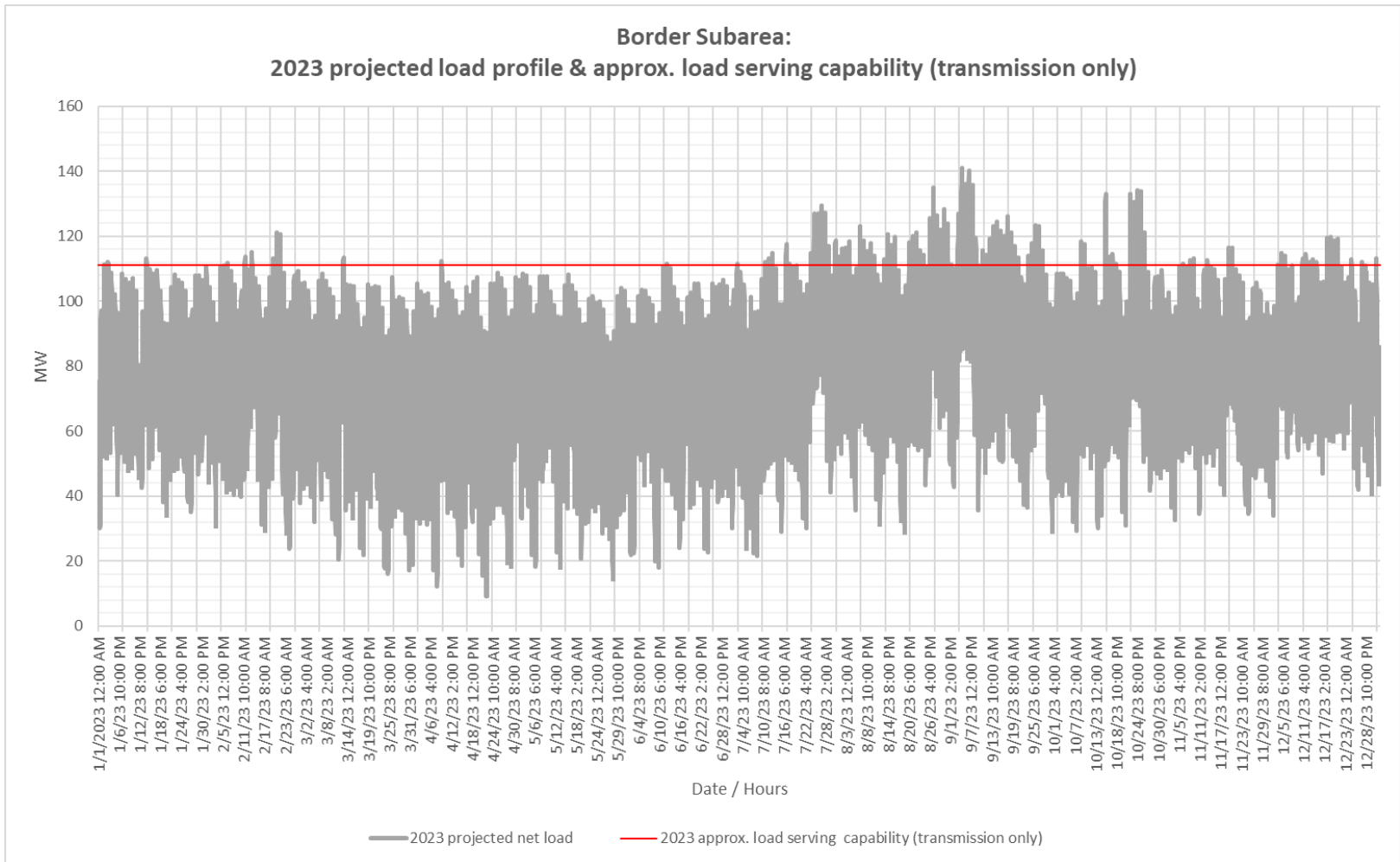

Border Sub-area Daily Load Profiles and L-1 Load Serving Capability - 2023

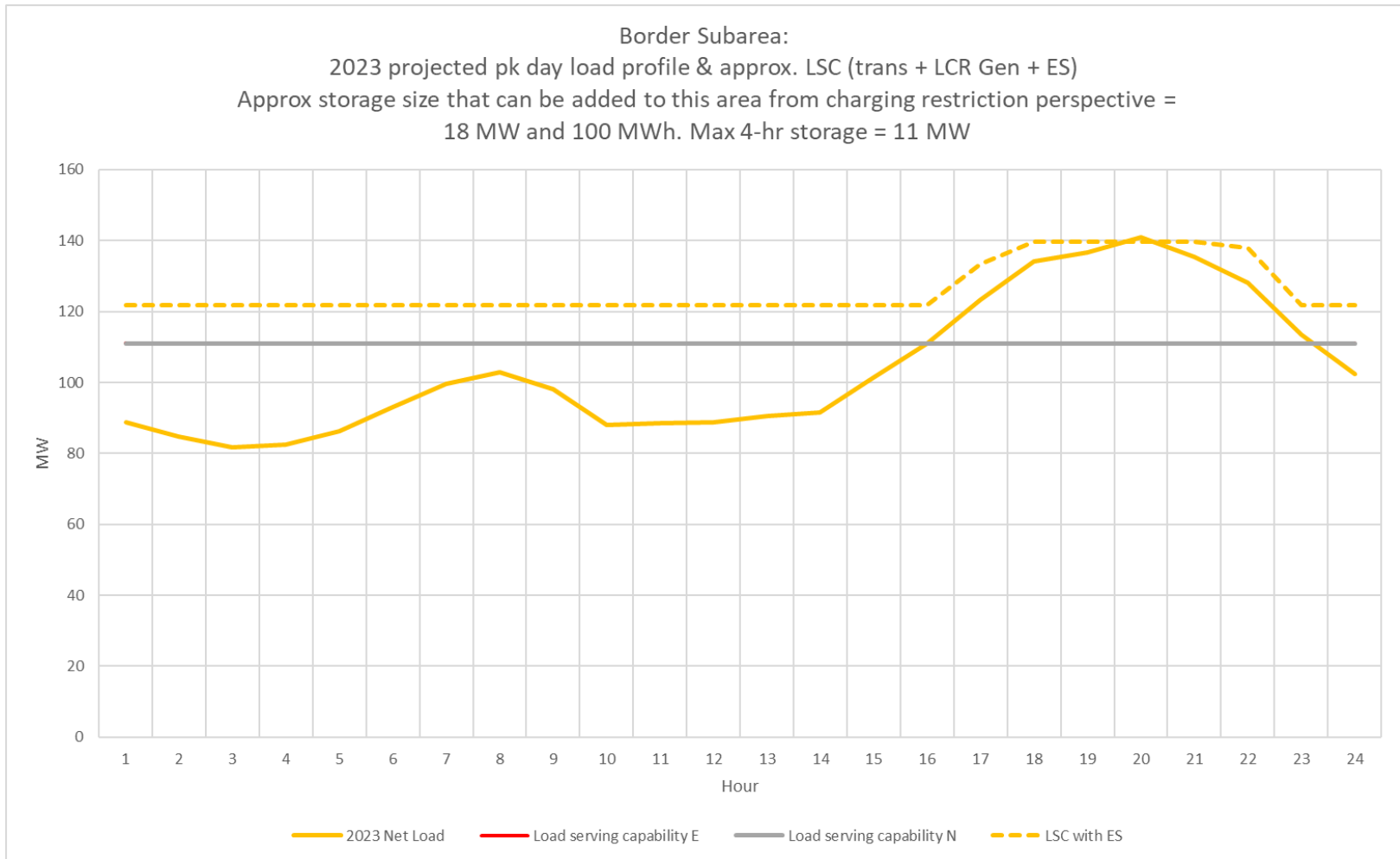

Border Sub-area Annual Load Profiles - 2027

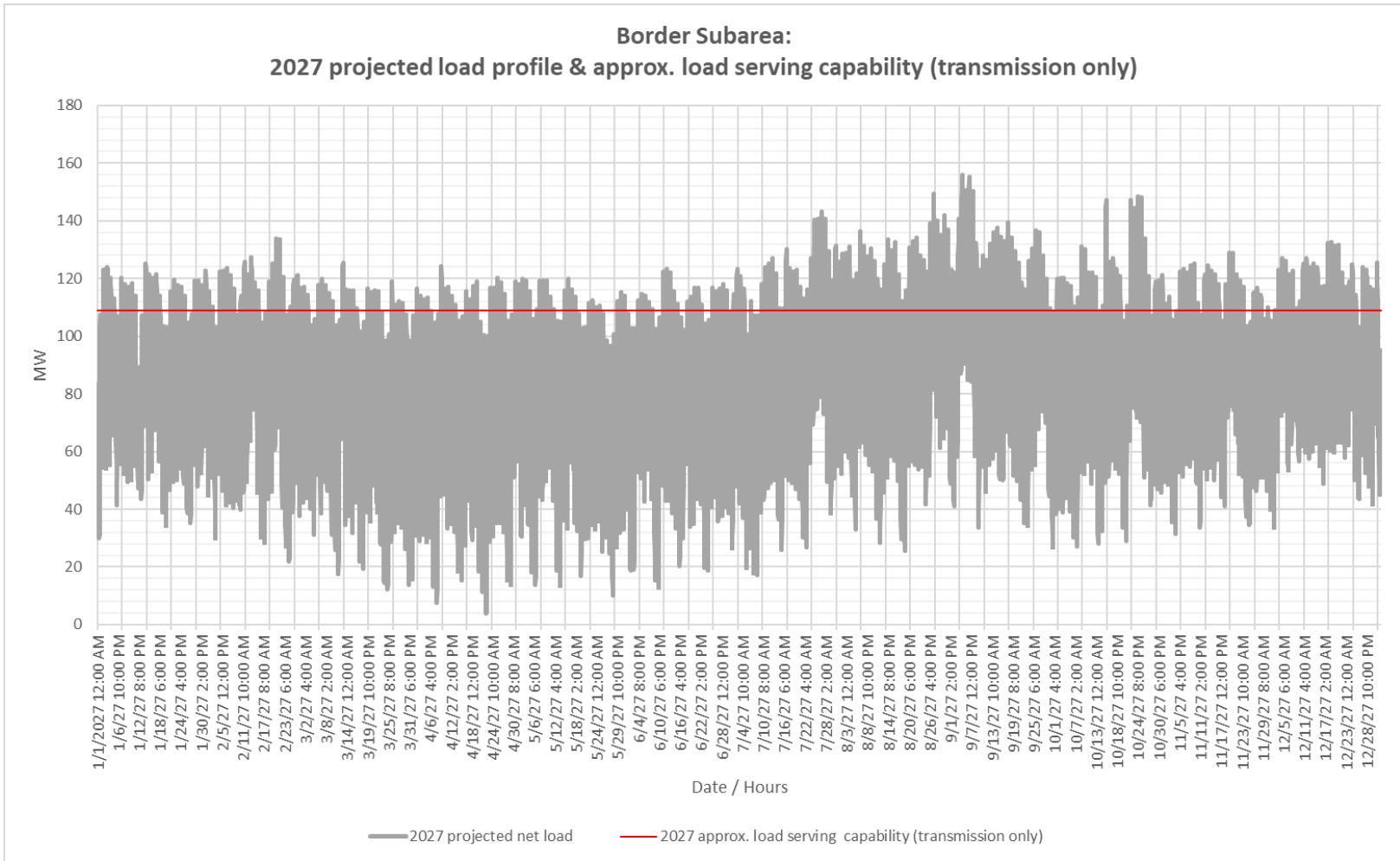

Border Sub-area Daily Load Profiles and L-1 Load Serving Capability - 2027

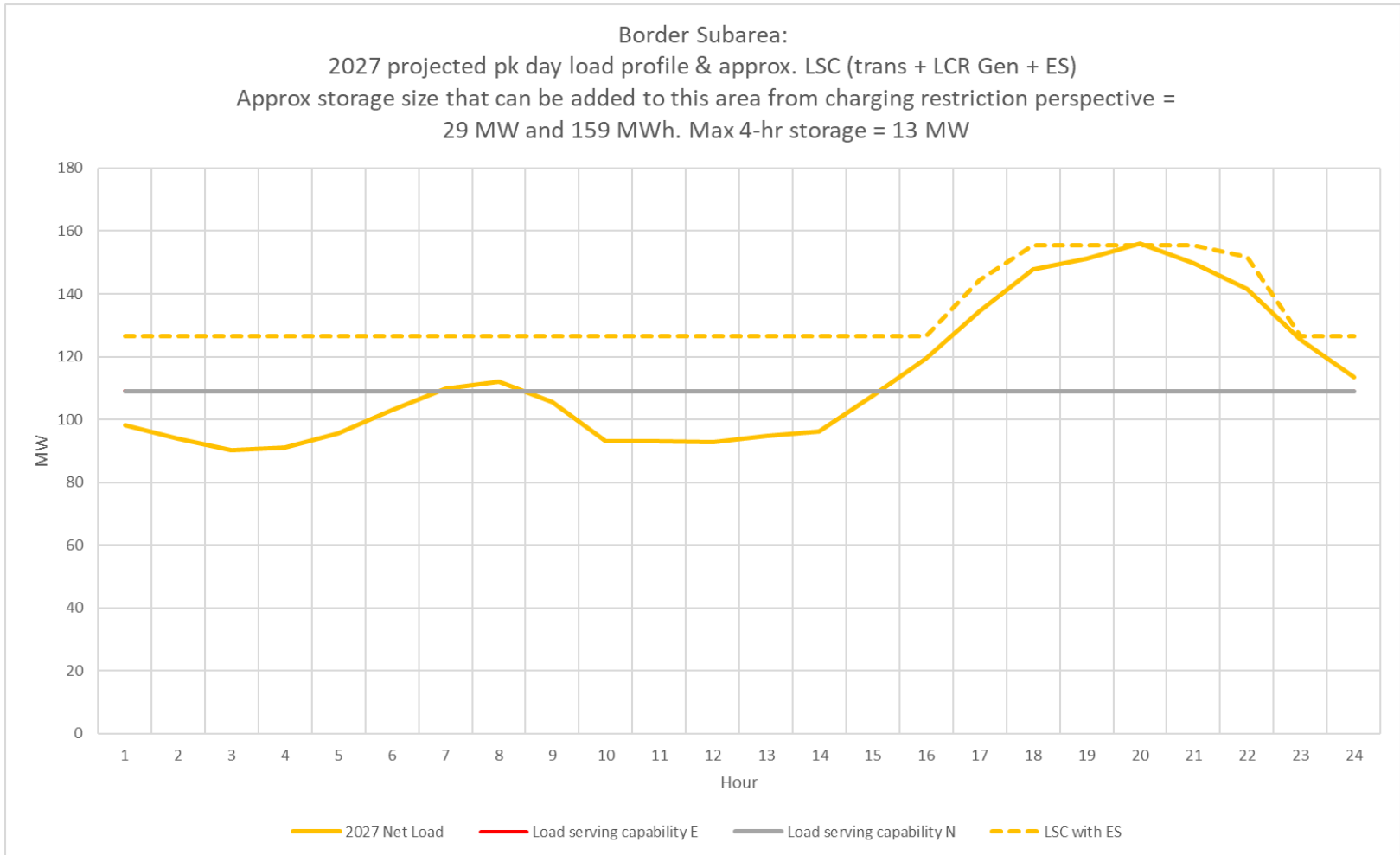

El Cajon Sub-area: Load and Resources

		2023	2027
Load (MW)	Gross Load	184	191
	AAEE	-1	-1
	Behand-The-Meter PV	0	0
	Net Load	183	190
	Transmission Loss	1	1
	Net Load + Loss	184	191
Resources (MW)	Gas-Fired	93.5	93.5
	Solar PV	0	0
	Wind	0	0
	QF/Other	0	0
	Demand Response	0	0
	Energy Storage	7.5	7.5

El Cajon Sub-area: One-line diagram

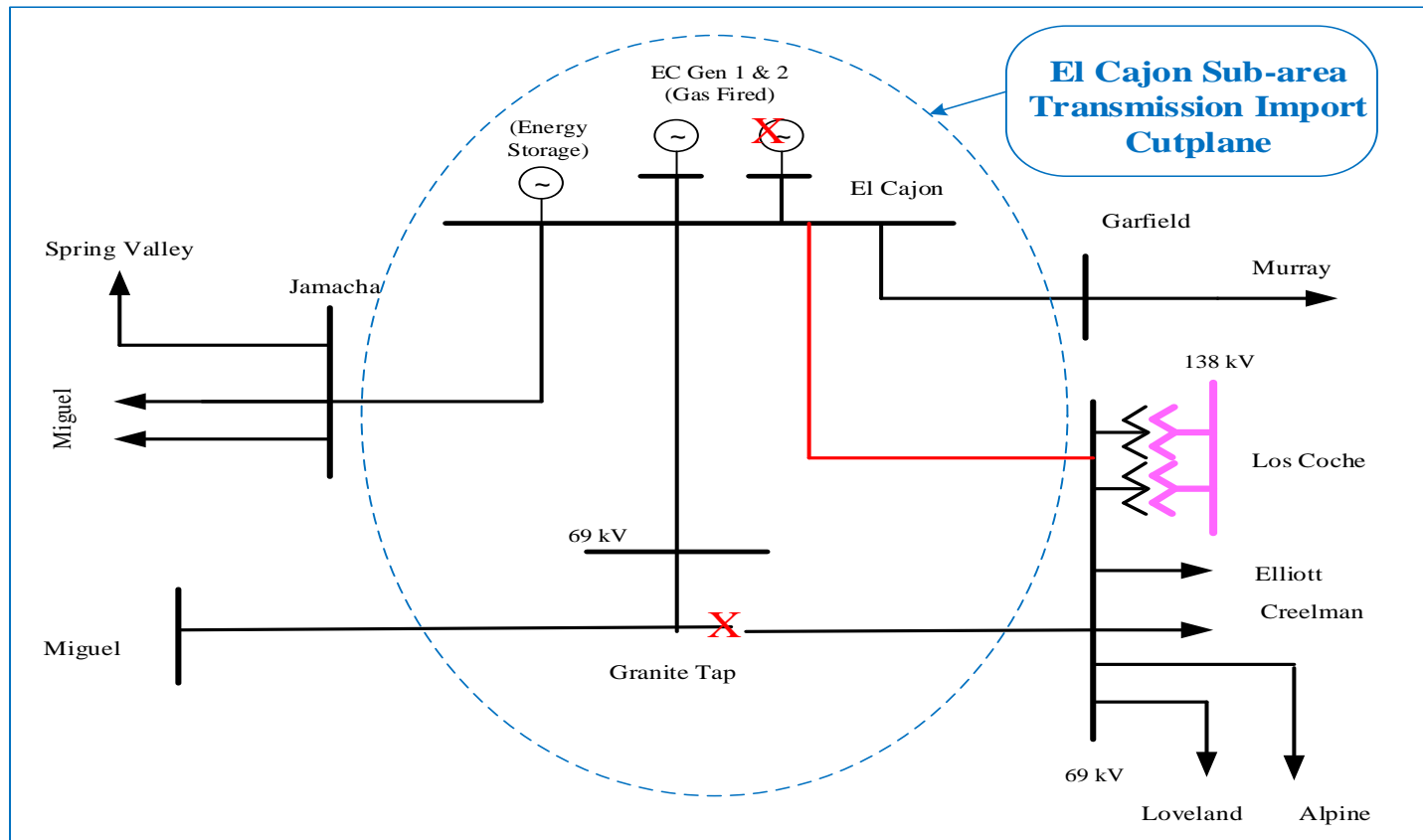

El Cajon Sub-area: LCR Requirement

Year	Category	Contingency	Limiting Facility	LCR (MW) (deficiency)
2023	P3	El Cajon unit out of service followed by the outage of TL632 Granite–Los Coches–Miguel 69 kV 3-terminal line	El Cajon-Los Coches 69 kV (TL631)	86
2027	P3	El Cajon unit out of service followed by the outage of TL632 Granite–Los Coches–Miguel 69 kV 3-terminal line	El Cajon-Los Coches 69 kV (TL631)	106 (5)

The LCR needs for the El Cajon sub-area in 2027 requires the additional dispatch of 5 MW of BESS to mitigate the overload of El Cajon - Los Coches 69 kV (TL631).

TL632 Granite loop-in and TL6914 reconfiguration project would eliminate this requirement, but is under review.

El Cajon Sub-area Annual Load Profiles - 2023

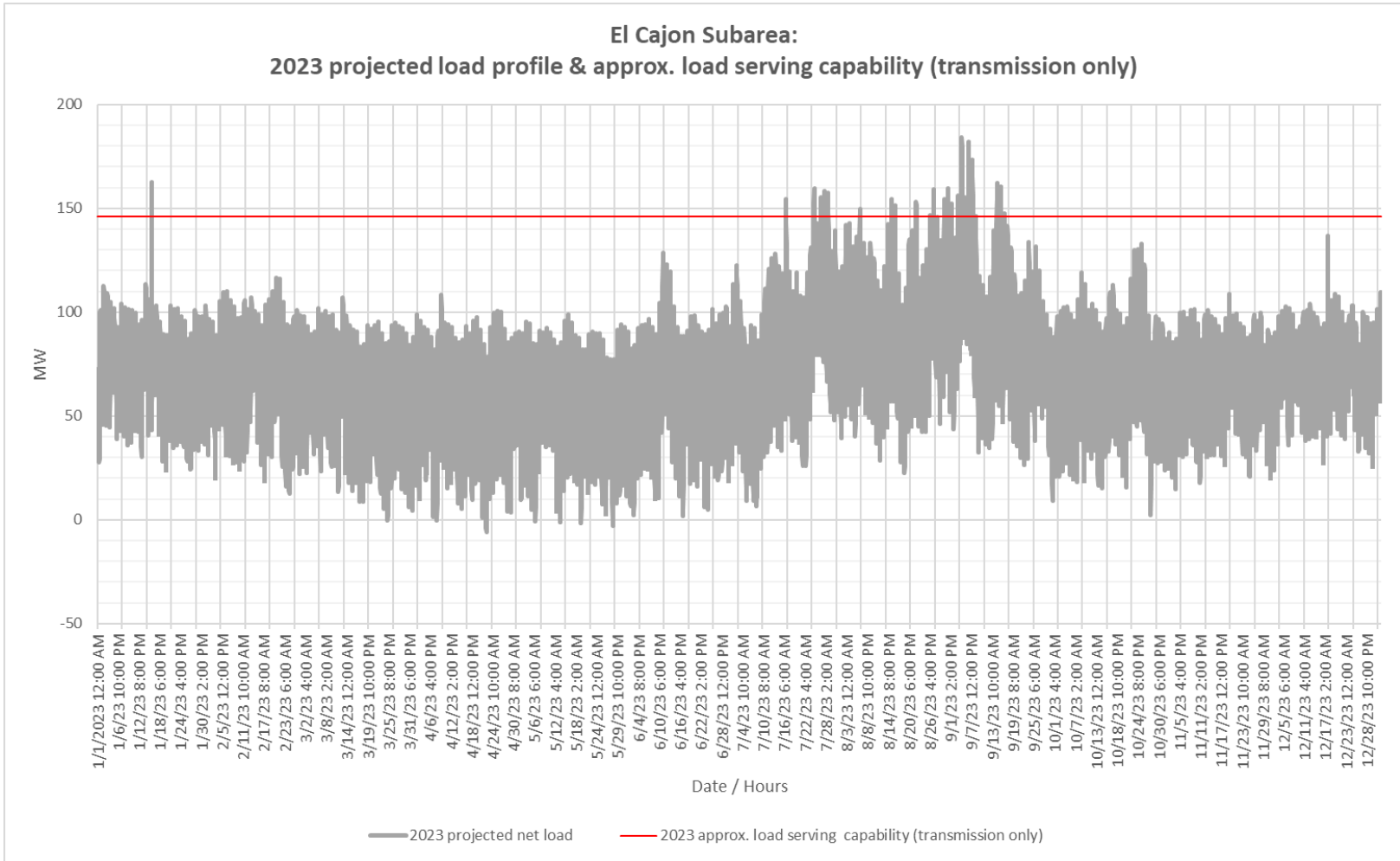

El Cajon Sub-Area Daily Load Profiles and L-1 Load Serving Capability - 2023

El Cajon Subarea:
 2023 projected pk day load profile & approx. LSC (trans + LCR Gen + ES)
 Approx storage size that can be added to this area from charging restriction perspective =
 60.5 MWh and 199 MWh. Max 4-hr storage = 13 MW

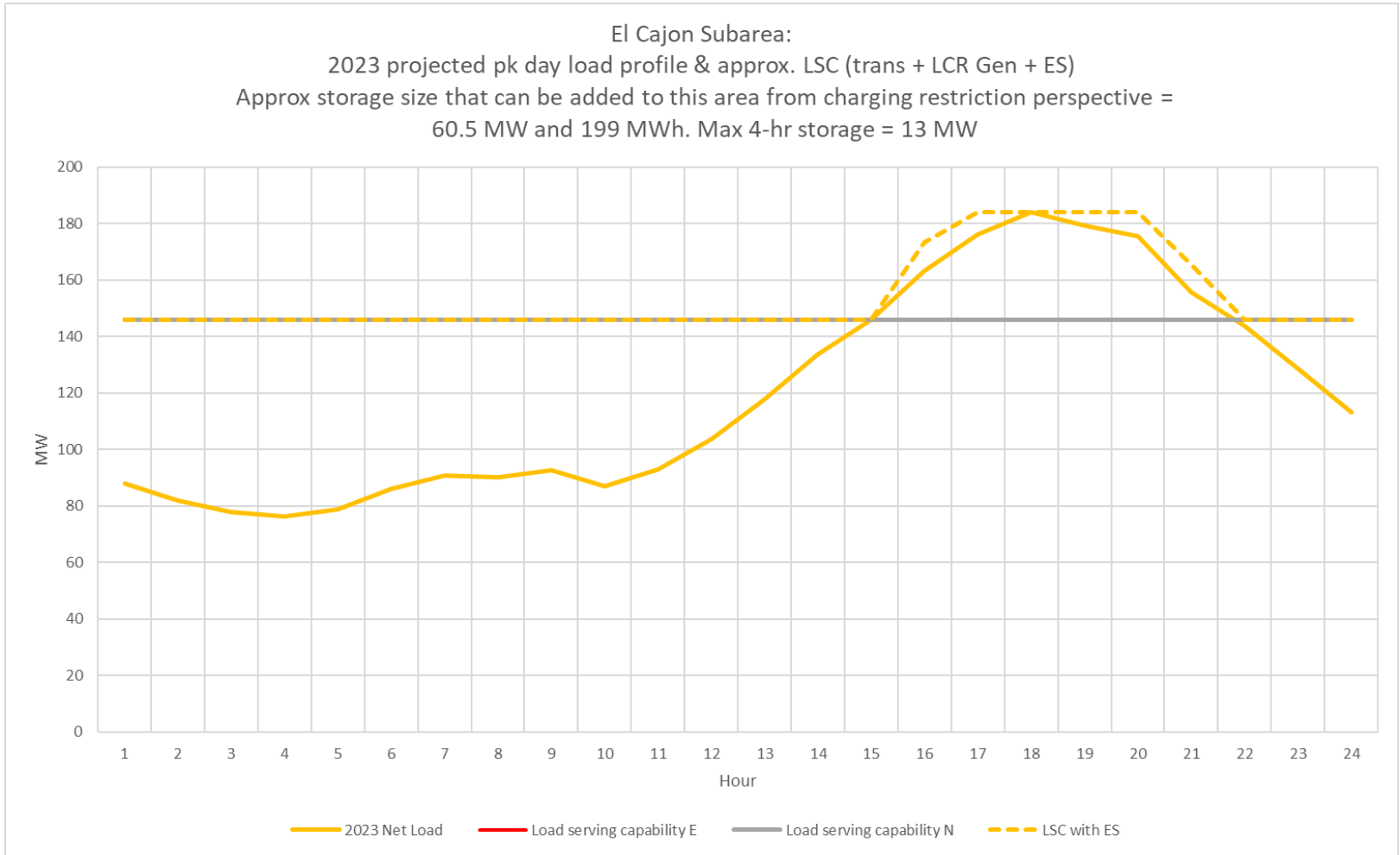

El Cajon Sub-area Annual Load Profiles - 2027

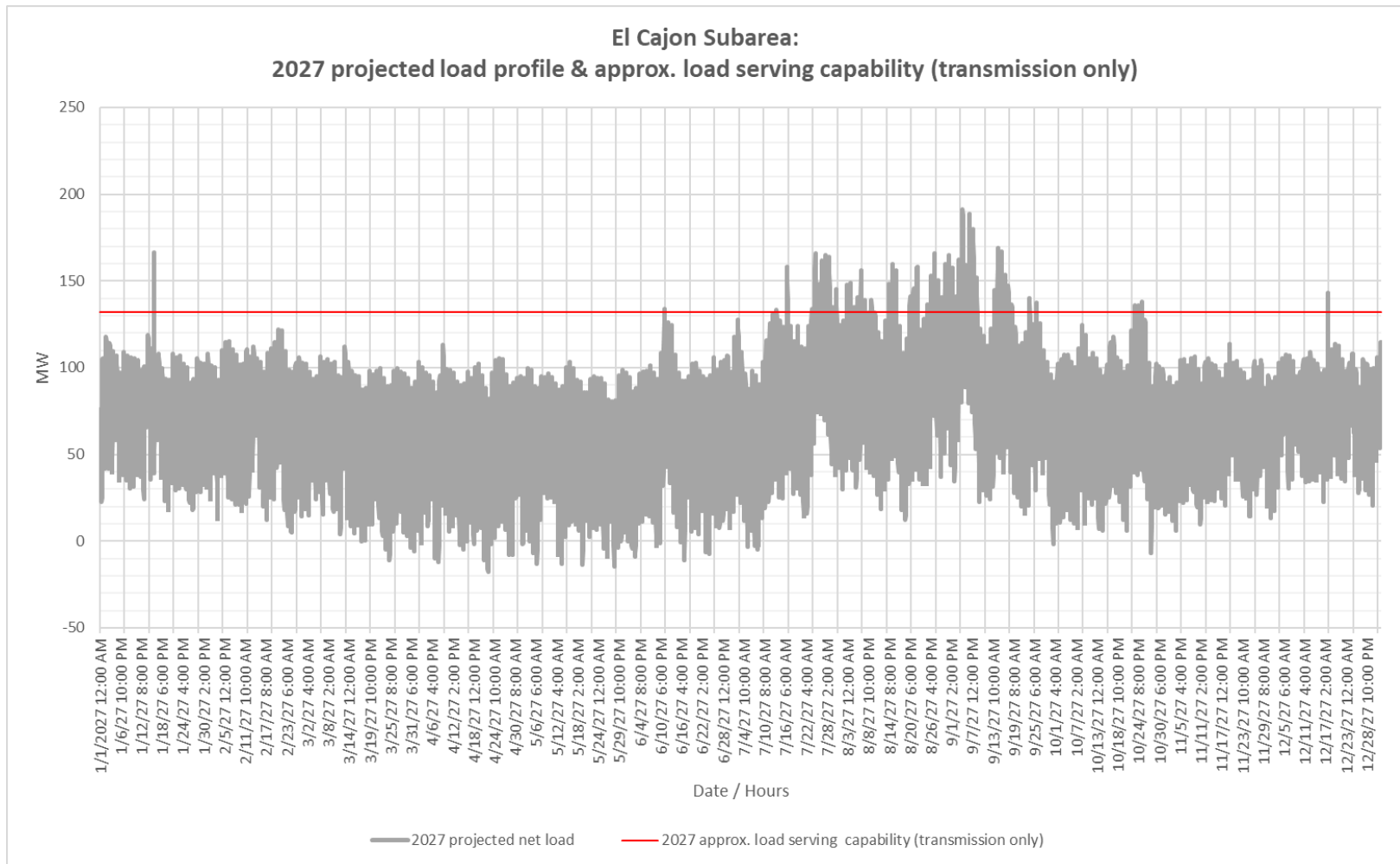

El Cajon Sub-Area Daily Load Profiles and L-1 Load Serving Capability - 2027

El Cajon Subarea:
2027 projected pk day load profile & approx. LSC (trans + LCR Gen + ES)
Approx storage size that can be added to this area from charging restriction perspective =
95 MW and 371 MWh. Max 4-hr storage = 13 MW

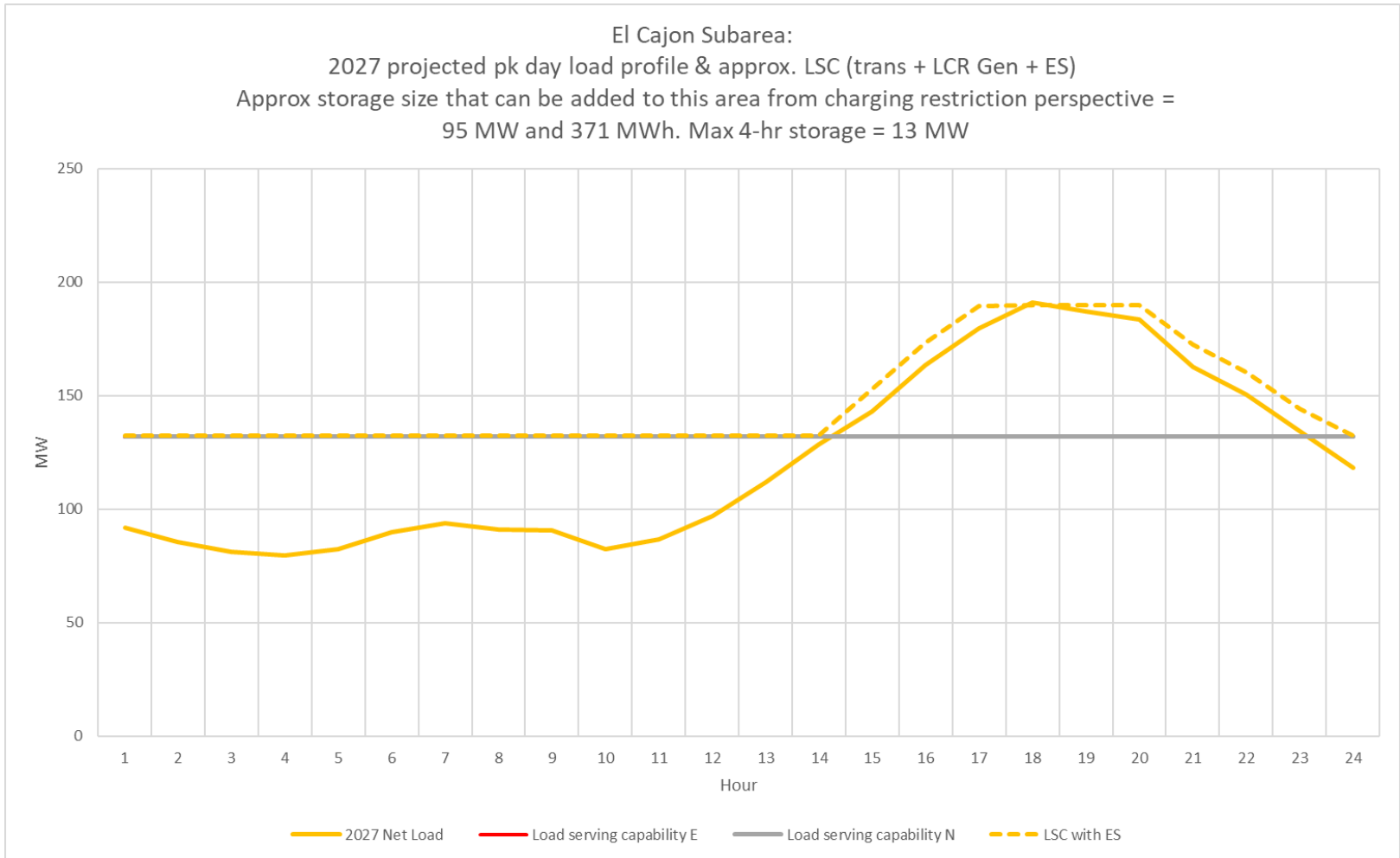

Changes Compared to Previous LCR Requirements

Sub-Area	2022 LCR	2026 LCR	2023 LCR	2027 LCR	Major Reason for LCR Change
	(MW)	(MW)	(MW)	(MW)	
Border	68	77	69	80	load forecast increase
El Cajon	88	99	86	106 (5)	load forecast increase, updated TL631 rating