

## **APPENDIX F: Detailed Policy Assessment**

**Intentionally left blank**

## Contents

F	Policy-Driven Need Assessment.....	5
F.1	Background .....	5
F.2	Objectives of policy-driven assessment.....	6
F.3	Study methodology and components .....	6
F.4	Resource Portfolios .....	8
F.4.1	Transmission capability estimates and utilization by portfolios .....	13
F.5	On-Peak Deliverability Assessment.....	16
F.5.1	On-peak deliverability assessment assumptions .....	17
F.5.2	General On-peak deliverability assessment procedure .....	19
F.6	Off-Peak Deliverability assessment.....	20
F.6.1	Off-peak deliverability assessment methodology .....	20
F.7	PG&E Greater Bay and North of Greater Bay Interconnection Area.....	24
F.7.1	On-peak results .....	25
F.7.2	Off-peak results .....	31
F.8	PG&E Greater Fresno Interconnection Area.....	32
F.8.1	On-peak results .....	33
F.8.2	Off-peak results .....	36
F.9	PG&E East Kern Interconnection Area .....	41
F.9.1	On-peak results .....	42
F.9.2	Off-peak results .....	44
F.10	East of Pisgah area.....	46
F.10.1	VEA 138 kV Area.....	47
F.10.2	GLW 230 kV Area.....	51
F.10.3	SCE East of Pisgah Area .....	59
F.10.4	Conclusion and recommendation .....	63
F.11	SCE Northern Area .....	65
F.11.1	On-peak results .....	66
F.11.2	Off-peak results .....	67
F.11.3	Conclusion and recommendation .....	72
F.12	SCE North of Lugo Area .....	72
F.12.1	On-peak results .....	74
F.12.2	Off-peak results .....	83
F.12.3	Conclusion and recommendation .....	89
F.13	SCE Metro Area .....	89
F.13.1	On-peak results .....	91
F.13.2	Off-peak results .....	102
F.13.3	Summary of Metro area results .....	103
F.14	SCE Eastern .....	104
F.14.1	On-peak results .....	105
F.14.2	Off-peak results .....	115
F.15	SDG&E area .....	119
F.15.1	On-peak results .....	119
F.15.2	Off-peak results .....	146
F.15.3	Conclusions and Recommendations for the SCE Metro and Eastern and SDG&E Area Mitigation Plan.....	148
F.16	Offshore Wind.....	151
F.16.1	Morro Bay Area .....	151
F.16.2	Humboldt off shore wind interconnection sensitivity.....	151

F.17 Out-of-State Wind ..... 157  
F.18 Transmission Plan Deliverability with Approved Transmission Upgrades . 157  
F.19 Production production cost model (PCM) results ..... 158

## F Policy-Driven Need Assessment

### F.1 Background

The overarching public policy objective for the California ISO's Policy-Driven Need Assessment is the state's mandate for meeting renewable energy and greenhouse gas (GHG) reduction targets while maintaining reliability. For the purposes of the transmission planning process, this high-level objective is comprised of two sub-objectives: first, to support Resource Adequacy (RA) deliverability status for the renewable generation and energy storage resources identified in the portfolio as requiring that status, and second, to support the economic delivery of renewable energy over the course of all hours of the year.

The more coordinated and proactive approach taken in the ISO's current annual transmission planning process is part of a larger set of interrelated and coordinated planning and resource development activities being undertaken between the state energy agencies and the ISO. The ISO, for example, relies in particular on the CPUC for its lead role in developing resource forecasts for the 10-year planning horizon, with both the ISO and CEC providing input to the CPUC for those resource forecasts. The ISO also relies on the CEC for its lead role in forecasting customer load requirements and the MOU signed by the three parties in December 2022 reaffirms our respective roles and commitment to ensure we are working in concert with one another. As such, the MOU also sets the overall strategic direction for tightening linkages among resource and transmission planning activities, interconnection processes and resource procurement so the three entities are synchronized in working for the timely integration of new resources.

The CPUC issued a Decision<sup>1</sup> on February 8, 2018, which adopted the integrated resource planning (IRP) process designed to ensure that the electric sector is on track to help the State achieve its 2030 GHG reduction target, at least cost, while maintaining electric service reliability and meeting other state goals. In subsequent years, the CPUC has been developing integrated resource plans and transmitting them to the ISO for use in the annual transmission planning process.

The CPUC issued Decision 22-02-004<sup>2</sup> on February 15, 2022 to transmit a portfolio based on the 38 million metric ton (MMT) greenhouse gas (GHG) target by 2030 and the 2020 Integrated Energy Policy Report demand forecast utilizing the high electric vehicle assumptions as the reliability and policy-driven base portfolio in the ISO 2022-2023 Transmission Planning Process (TPP). The portfolio includes a 2032 GHG target of 35 MMT, consistent with the ten-year nature of the portfolio. The Decision is accompanied by Attachment A,<sup>3</sup> which provides the methodology and results of the resources-to-busbar mapping process as well as other assumptions for use in the ISO TPP.

---

<sup>1</sup> <https://docs.cpuc.ca.gov/PublishedDocs/Published/G000/M209/K878/209878964.PDF>

<sup>2</sup> <https://docs.cpuc.ca.gov/PublishedDocs/Published/G000/M451/K412/451412947.PDF>

<sup>3</sup> <https://docs.cpuc.ca.gov/PublishedDocs/Published/G000/M451/K485/451485713.PDF>

Decision 22-02-004 also delegated to the Commission's Energy Division staff the development of a policy-driven sensitivity portfolio and associated busbar mapping based on a 30 million metric ton greenhouse gas target in consultation with staff of the California Energy Commission (CEC) and the ISO. Accordingly, the 2022-23 TPP High Electrification Sensitivity Portfolio was developed and transmitted to the ISO on July 1, 2022. In the transmittal letter,<sup>4</sup> the CPUC and CEC requested the ISO to:

- To use the 2021 Integrated Energy Policy Report (IEPR) Additional Transportation Electrification scenario as its load assumptions for 2022-23 Transmission Planning Process (TPP) base and sensitivity case studies;
- To study the 30 million metric ton (MMT) High Electrification policy-driven sensitivity portfolio transmitted as the 2022-23 TPP High Electrification Sensitivity Scenario; and
- To continue studying the deliverability needs and corresponding transmission needs related to out-of-CAISO long-lead time resources, such as out-of-state wind and geothermal resources beyond the CAISO's balancing authority area. The letter further requested the ISO to assess the deliverability needs of these long lead-time resources while preserving the existing transmission capacity that has been allocated to other projects earlier in the queue.

## F.2 Objectives of policy-driven assessment

Key objectives of the policy-driven assessment are to:

- Assess the transmission impacts of portfolio resources using:
  - Reliability assessment,
  - Peak and Off-peak deliverability assessment, and
  - Production cost simulation;
- Identify transmission upgrades or other solutions needed to ensure reliability deliverability or alleviate excessive curtailment; and
- Gain further insights to inform future portfolio development.

## F.3 Study methodology and components

The policy-driven assessment is an iterative process comprised of three types of technical studies as illustrated in Figure F.3-1. These studies are geared towards capturing the impact of resource build-out on transmission infrastructure, identifying any required upgrades and generating transmission input for use by the CPUC in the next cycle of portfolio development.

---

<sup>4</sup> <https://www.cpuc.ca.gov/-/media/cpuc-website/divisions/energy-division/documents/integrated-resource-plan-and-long-term-procurement-plan-irp-ttp/2019-2020-irp-events-and-materials/ttp-portfolio-transmittal-letter.pdf>

Figure F.3-1: Policy-Driven Assessment Technical Studies

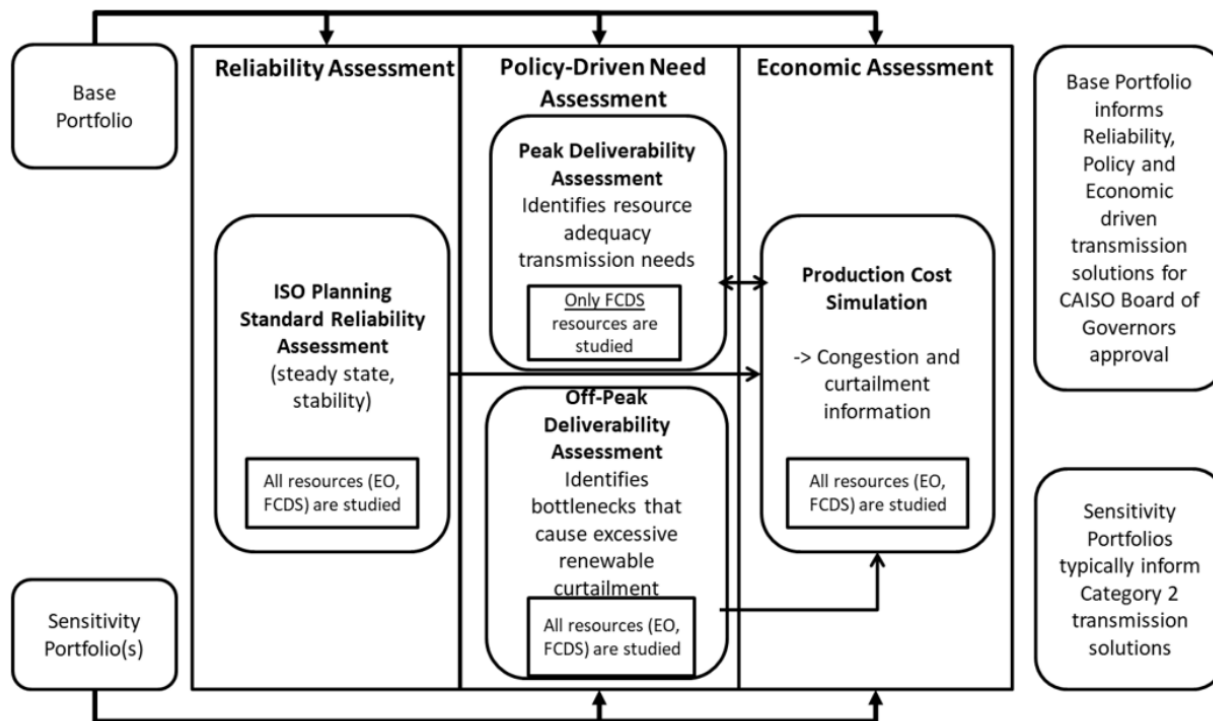

**Reliability assessment**

The CPUC’s base resource portfolio is a key input in the ISO’s long term reliability assessment. The reliability assessment is used to assess transmission needs in accordance with NERC, WECC and CAISO transmission planning standards and criteria. It is also used to identify constraints and potential solutions that may be modeled in production cost simulations to assess the impact of the constraints on congestion and renewable curtailment, which may lead to identification of economic transmission projects. The reliability assessment is presented in Chapter 2 and Appendix B.

**On-peak deliverability assessment**

The on-peak deliverability assessment is designed to ensure portfolio resources selected with full capacity deliverability status (FCDS) are deliverable and can count towards meeting resource adequacy needs. The assessment examines whether sufficient transmission capability exists to transfer resource output from a given area to the aggregate of the ISO control-area load when the generation is needed most. The ISO performs the assessment in accordance with its On-peak Deliverability Assessment Methodology.<sup>5</sup>

<sup>5</sup> <http://www.caiso.com/Documents/On-PeakDeliverabilityAssessmentMethodology.pdf>

### Off-peak deliverability assessment

The off-peak deliverability assessment is performed to identify potential transmission system limitations that may cause excessive renewable energy curtailment. Like the reliability assessment, the offpeak assessment is also used to identify constraints and transmission solutions as candidates for detailed production cost simulation studies and economic assessment. The ISO performs the assessment in accordance with its Off-Peak Deliverability Assessment Methodology.<sup>6</sup>

### Production cost model (PCM) simulation

Production cost models for the base and sensitivity portfolios are developed and simulated to identify renewable curtailment and transmission congestion in the ISO Balancing Authority Area. The PCM for the base portfolio is used in the policy-driven assessment that is covered in this section as well as the economic assessment covered in Chapter 3 and Appendix G. The PCM with the sensitivity portfolios is used in the policy-driven assessment only. The PCM cases are developed based on study assumptions for the ISO-controlled grid outlined in the 2022-2023 transmission planning process study plan. Details of PCM modeling assumptions and approaches are provided in Appendix G.

## F.4 Resource Portfolios

As mentioned in Section F.1, a base portfolio and a sensitivity portfolio were transmitted by the CPUC for study in the ISO 2022-2023 transmission planning process. The portfolio documents are available at the CPUC website.<sup>7</sup>

The following documents provide details regarding the base portfolio.

Busbar mapping results for the base portfolio:

[https://files.cpuc.ca.gov/energy/modeling/BusbarMapping\\_Dashboard\\_38MMT\\_V2022\\_02\\_08\\_v2.xlsx](https://files.cpuc.ca.gov/energy/modeling/BusbarMapping_Dashboard_38MMT_V2022_02_08_v2.xlsx) (particularly the worksheet tabs 'FinalMapping\_bySub' and '2\_Tx\_Calculator\_R5')

Baseline resource assumptions:

[https://files.cpuc.ca.gov/energy/modeling/Baseline\\_Reconciliation\\_V2022\\_02\\_08.xlsx](https://files.cpuc.ca.gov/energy/modeling/Baseline_Reconciliation_V2022_02_08.xlsx)

Thermal Age Based Retirements Assumptions:

[https://files.cpuc.ca.gov/energy/modeling/Thermal%20Age%20Based%20Retirements%20Assumptions\\_V2021\\_10\\_15.xlsx](https://files.cpuc.ca.gov/energy/modeling/Thermal%20Age%20Based%20Retirements%20Assumptions_V2021_10_15.xlsx)

Final busbar mapping results for the base portfolio with resource additions and adjustments to the base portfolio to account for PTO identified in-development resources and TPD allocated resources in applicable areas: [https://files.cpuc.ca.gov/energy/modeling/BaseCase\\_updated\\_in-dev\\_andTPD\\_9-21-22.xlsx](https://files.cpuc.ca.gov/energy/modeling/BaseCase_updated_in-dev_andTPD_9-21-22.xlsx)

The following documents provide details regarding the sensitivity portfolio.

---

<sup>6</sup> <http://www.caiso.com/Documents/Off-PeakDeliverabilityAssessmentMethodology.pdf>

<sup>7</sup> <https://www.cpuc.ca.gov/industries-and-topics/electrical-energy/electric-power-procurement/long-term-procurement-planning/2019-20-irp-events-and-materials>



Busbar mapping results for the sensitivity portfolio: [https://www.cpuc.ca.gov/-/media/cpuc-website/divisions/energy-division/documents/integrated-resource-plan-and-long-term-procurement-plan-irp-ltpp/2019-2020-irp-events-and-materials/busbarmapping\\_30\\_mmt\\_hesensitivity\\_dashboard\\_07\\_01\\_22.xlsx](https://www.cpuc.ca.gov/-/media/cpuc-website/divisions/energy-division/documents/integrated-resource-plan-and-long-term-procurement-plan-irp-ltpp/2019-2020-irp-events-and-materials/busbarmapping_30_mmt_hesensitivity_dashboard_07_01_22.xlsx)

Final busbar mapping with resource adjustments to the sensitivity portfolio to account for PTO identified in-development resources and TPD allocated resources in applicable areas  
[https://files.cpuc.ca.gov/energy/modeling/BusbarMapping\\_30MMT\\_HESENS\\_Dashboard\\_08\\_22\\_22\\_TPD\\_v2.xlsx](https://files.cpuc.ca.gov/energy/modeling/BusbarMapping_30MMT_HESENS_Dashboard_08_22_22_TPD_v2.xlsx)

The composition of each of the portfolios by resource type is provided in Table F.4-1. The table includes resources selected with Full Capacity Deliverability Status (FCDS) as well as those selected as Energy Only (EO). The portfolios are comprised of solar, wind (in-state, out-of-state and offshore), battery storage, geothermal, long duration energy storage, biomass/biogass and distributed solar resources. All portfolio resources are modeled in policy-driven assessments except in the on-peak deliverability assessment in which only FCDS resources are modeled. The portfolios assume some of the existing gas-fired generation fleet will be retired by 2032 based on age.

Table F.4-1: Portfolio composition – FCDS+EO resources (MW)<sup>8</sup>

Resource Type	Base Portfolio			Sensitivity Portfolio		
	FCDS (MW)	EO (MW)	Total (MW)	FCDS (MW)	EO (MW)	Total (MW)
Solar	5,490	11,889	17,379	11,806	28,948	40,754
Wind – In State	2,533	499	3,032	2,697	546	3,244
Wind – Out-of-State (Existing TX)	610	-	610	610	-	610
Wind – Out-of-State (New TX)	1,500	-	1,500	4,828	-	4,828
Wind - Offshore	1,588	120	1,708	4,587	120	4,707
Li Battery	13,564	-	13,564	28,402	-	28,402
Geothermal	1,159	-	1,159	1,794	-	1,794
Long Duration Energy Storage (LDES)	1,000	-	1,000	2,000	-	2,000
Biomass/Biogass	134	-	134	134	-	134
Distributed Solar	125	-	125	125	-	125
<b>Total</b>	<b>27,703</b>	<b>12,508</b>	<b>40,211</b>	<b>57,246</b>	<b>29,352</b>	<b>86,598</b>

The CPUC has provided guidance regarding the treatment of out-of-state resources in the portfolios. For the 1,500 MW of OOS resources on new transmission in the current base portfolio, the CPUC mapped 1,062 MW to the El Dorado injection point and 438 MW to the Palo Verde injection point. The El Dorado injection point is meant to enable either Idaho Wind or Wyoming Wind to interconnect. According to the CPUC, the 438 MW of OOS wind at Palo Verde captures the potential for additional wind imported from New Mexico that aligns with recent inclusion of OOS wind from this area as identified in the baseline reconciliation process. These out of state resources on new transmission were assumed to require MIC expansion in the policy-driven deliverability assessment.

<sup>8</sup> [https://files.cpuc.ca.gov/energy/modeling/BusbarMapping\\_30MMT\\_HESENS\\_Dashboard\\_08\\_22\\_22\\_TPD\\_v2.xlsx](https://files.cpuc.ca.gov/energy/modeling/BusbarMapping_30MMT_HESENS_Dashboard_08_22_22_TPD_v2.xlsx)

In their July 1, 2022 transmittal Letter to CAISO for 2022-23 TPP High Electrification Sensitivity Portfolio, the CPUC and CEC asked the ISO to use the 2021 Integrated Energy Policy Report (IEPR) Additional Transportation Electrification scenario as its load assumptions for 2022-23 Transmission Planning Process (TPP) base and sensitivity case studies and to continue studying the deliverability needs and corresponding transmission needs related to out-of CAISO long-lead time resources, such as out-of-state wind and geothermal resources beyond the CAISO's balancing area authority. The agencies further requested the ISO studies to inform and enable the development of incremental transmission capacity to support these long lead-time resources be undertaken while preserving the existing transmission capacity that has been allocated to other projects earlier in the queue.

In order to minimize the increase in the amount of resources modeled in the ISO studies due to additional in-development resources that were identified by PTOs in accordance with the ISO study plan as well as the addition of TPD allocated resources, the ISO requested CPUC staff to make adjustments to the amount of generic resources. Accordingly, CPUC staff made adjustments to the portfolios and also provided the TPD-allocated amounts that were not accounted for by the adjustment, in particular in the case of the base portfolio, for the ISO to model. Table F.4-2 provides the adjustments to the base portfolio to account for the additional in-development resources and TPD allocations.<sup>9</sup>

Table F.4-2: Adjustments to the base portfolio to account for adjustments to in-development resources and TPD allocations

	<b>FCDS (MW)</b>	<b>EO (MW)</b>	<b>Total (MW)</b>
Solar	1,055	771	1,826
Wind – In State	15	0	15
Wind – Out-of-State (Existing TX)	-	-	-
Wind – Out-of-State (New TX)	-	-	-
Wind - Offshore	-	-	-
Li Battery	5,284	0	5,284
Geothermal	8	0	8
Long Duration Energy Storage (LDES)	-	-	-
Biomass/Biogass	-	-	-
Distributed Solar	-	-	-
<b>Total</b>	<b>6,362</b>	<b>771</b>	<b>7,133</b>

In the administrative law judge's ruling seeking comments on electricity resource portfolios for 2023-2024 transmission planning process, CPUC further indicated that the July 1, 2022, letter recommendations were intended to encourage the CAISO to consider identifying transmission needs, not only from study of the 38 MMT base case, but also from the study of the 30 MMT sensitivity, for approval within the 2022-2023 TPP. The CPUC made this recommendation considering the 30 MMT High Electrification sensitivity passed to 2022-2023 TPP is very similar

<sup>9</sup> [https://files.cpuc.ca.gov/energy/modeling/BaseCase\\_updated\\_in-dev\\_andTPD\\_9-21-22.xlsx](https://files.cpuc.ca.gov/energy/modeling/BaseCase_updated_in-dev_andTPD_9-21-22.xlsx)

to the 30 MMT HE portfolio proposed for the 2023-2024 TPP base case in the ruling. In their comments on the ISO's policy-driven deliverability assessment, CPUC staff clarified that although the two portfolios are similar in design, some mapping details can vary, and this can play a role in transmission need outcomes. Accordingly, CPUC staff suggested that the CAISO take under consideration the 23-24 TPP base case portfolio when evaluating transmission needs resulting from the 22-23 policy driven sensitivities.

The ISO was requested to study all three transmission alternatives identified in the 2021-2022 TPP for the 1487 MW of Humboldt area FCDS offshore wind in the sensitivity study in both the deliverability assessment and the production cost modeling to obtain additional insight into the varied benefits and costs of each option within a much larger sensitivity portfolio. Accordingly, the ISO has studied all three interconnection alternatives for Humboldt off-shore wind in the sensitivity portfolio. Mapping of portfolio resources to transmission substations

The portfolios that RESOLVE generates are at the zonal level. As a result, the portfolios have to be mapped to the busbar level for use in the ISO transmission planning process. The resource-to-busbar mapping process is documented in the CPUC report entitled Methodology for Resource-to-Busbar Mapping & Assumptions for the Annual TPP<sup>10</sup> with further refinements as described in the CPUC staff report entitled Modeling Assumptions for the 2022-2023 Transmission Planning Process.<sup>11</sup> Figure F.4-1 shows a flowchart of the CPUC busbar mapping process for the 2022-2023 transmission planning process.

---

<sup>10</sup> [https://files.cpuc.ca.gov/energy/modeling/Busbar%20Mapping%20Methodology%20for%20the%20TPP\\_V2021\\_12\\_21.pdf](https://files.cpuc.ca.gov/energy/modeling/Busbar%20Mapping%20Methodology%20for%20the%20TPP_V2021_12_21.pdf)

<sup>11</sup> <https://docs.cpuc.ca.gov/PublishedDocs/Published/G000/M451/K485/451485713.PDF>

Figure F.4-1: Flowchart of the CPUC 2022-2023 TPP busbar mapping process<sup>12</sup>

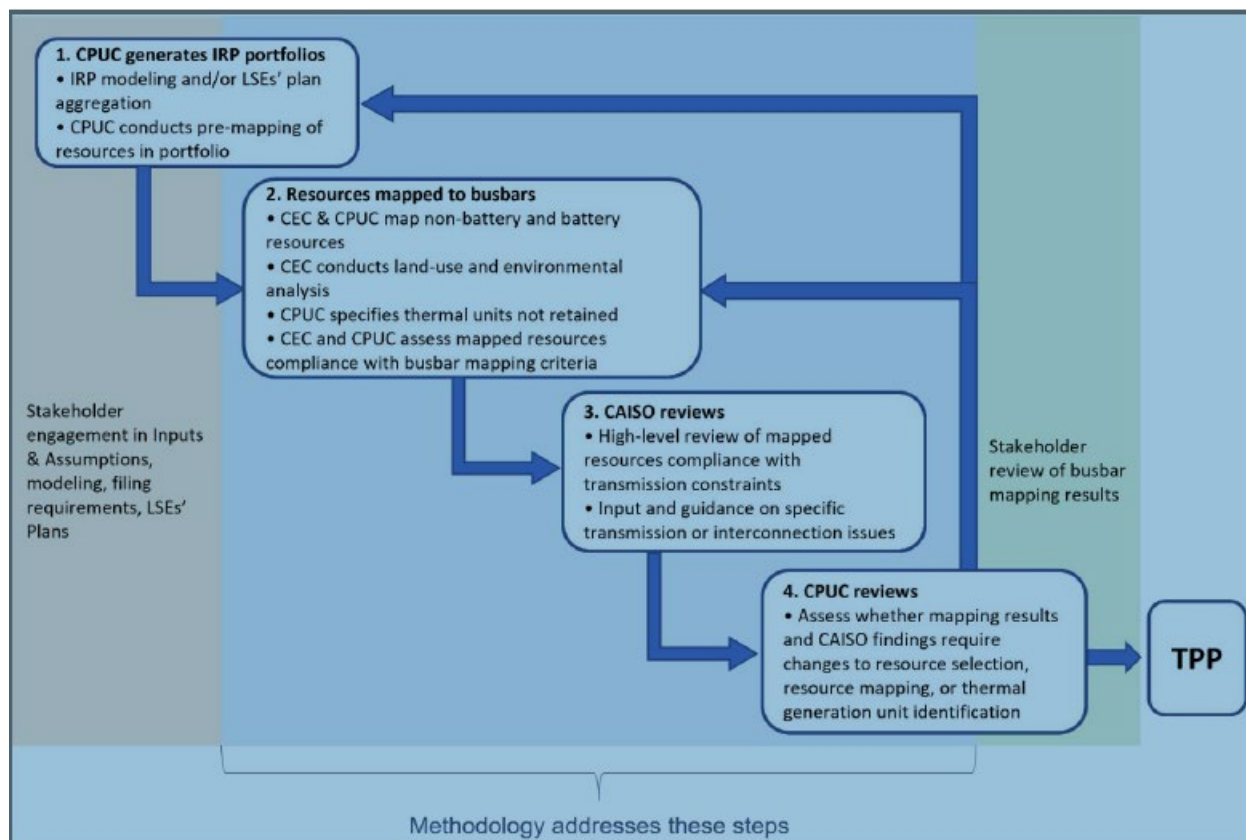

The portfolio resources were modeled in the ISO studies in accordance with the results of the mapping process. Figure F.4-2 below identifies the interconnection areas and the capacities of the resources in the CPUC's base and sensitivity portfolios. The resource types within each interconnection area and the mapping of the resources is provided in the sections below. Links to the detailed busbar mapping results have been provided in section F.4.

<sup>12</sup>[https://files.cpuc.ca.gov/energy/modeling/Busbar%20Mapping%20Methodology%20for%20the%20TPP\\_V2021\\_12\\_21.pdf](https://files.cpuc.ca.gov/energy/modeling/Busbar%20Mapping%20Methodology%20for%20the%20TPP_V2021_12_21.pdf)

Figure F.4-2: Base and Sensitivity Portfolios Total MW in each Interconnection Area

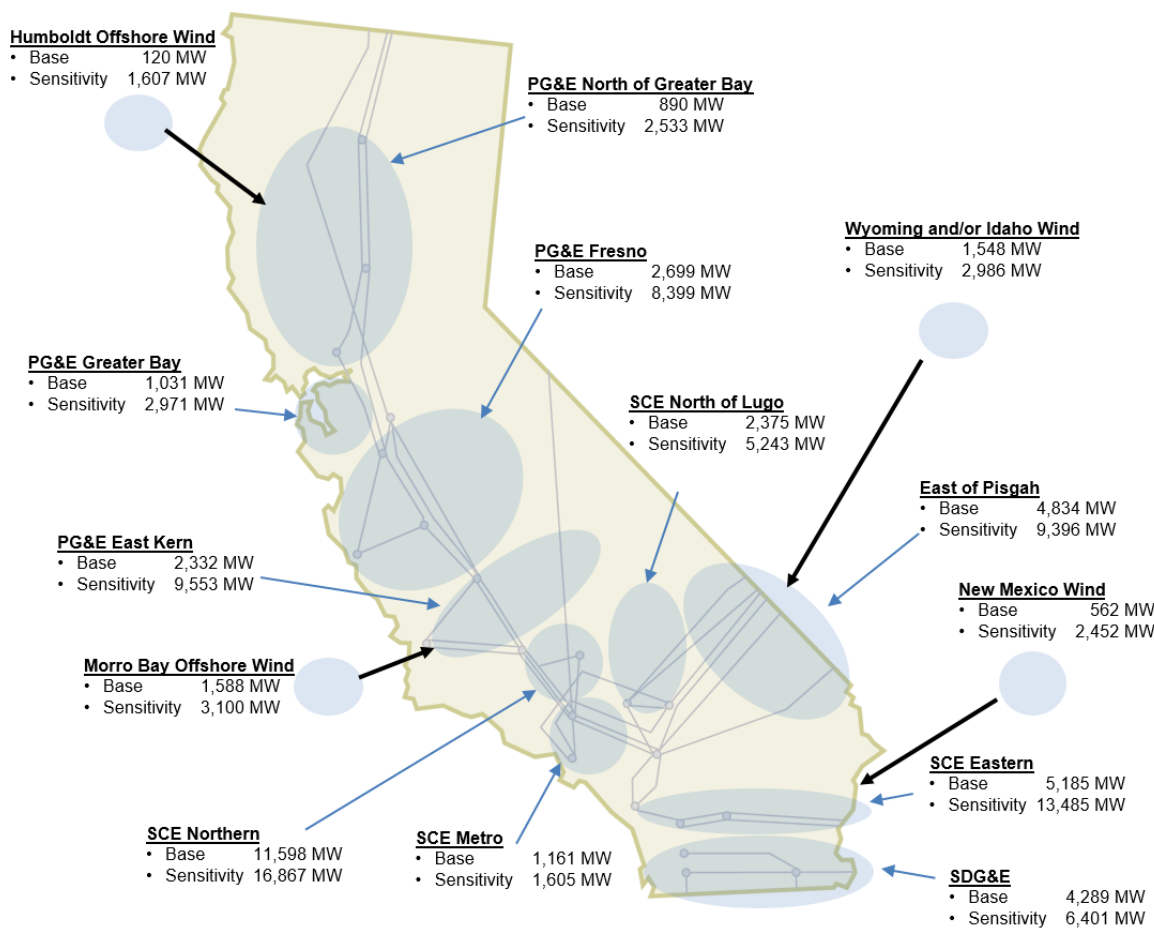

### F.4.1 Transmission capability estimates and utilization by portfolios

One of the key inputs in the portfolio development and busbar mapping process is the transmission capability estimates provided by the ISO. The transmission capability estimates limit the amount of FCDS and EODS resources that can be selected in the part of the system that is affected by the constraint. The transmission capability estimates the ISO published in a white paper on July 19, 2021<sup>13</sup> were used in the development of the resources portfolios for the current TPP. Some capability estimates have been updated by CPUC based on information provided in the ISO 2021-2022 Transmission Plan.

The utilization of estimated available FCDS and EODS transmission capability by the resource portfolios is monitored by the CPUC in the portfolio development process using RESOLVE and

<sup>13</sup> <http://www.caiso.com/Pages/documentsbygroup.aspx?GroupID=79BEBAD0-E696-4E04-A958-1AAF53A12248>

in the busbar mapping process using spreadsheet calculations. The results of the evaluation for the original base and sensitivity portfolios for the current TPP as well as for the 2023-2024 TPP 2035 base portfolio are posted on the CPUC website.<sup>14,15,16</sup> It is to be noted that since the evaluation for the base portfolio referenced above does not include the subsequent additions and adjustments made to the portfolios to account for additional in-development resources identified by PTOs and TPD allocated resources, the ISO is using the calculations provided by CPUC staff in response to the ISO's request.

Exceedances of actual transmission capability limits indicate a high likelihood of the need for transmission upgrades or other mitigation solutions for the delivery of portfolio resources behind the constraints, which the CPUC takes into account in the development and mapping of the resource portfolios. However, the spreadsheet analysis should not be viewed as a substitute for the analysis the ISO performs as part of this policy-driven assessment using detailed power system models.

Table F.4-3 and Table F.4-4 show the transmission constraints where FCDS or EODS capability estimates are exceeded in one or more portfolio. The transmission capability estimates as well as the exceedance amounts provided in the tables are expressed in terms of the applicable resource-type specific output assumptions used in deliverability assessments as described in subsequent sections rather than installed capacity.

---

<sup>14</sup> [https://files.cpuc.ca.gov/energy/modeling/BusbarMapping\\_Dashboard\\_38MMT\\_V2022\\_02\\_08\\_v2.xlsx](https://files.cpuc.ca.gov/energy/modeling/BusbarMapping_Dashboard_38MMT_V2022_02_08_v2.xlsx) (See tab labeled "2\_Tx\_Calculator\_R5")

<sup>15</sup> [https://files.cpuc.ca.gov/energy/modeling/BusbarMapping\\_30MMT\\_HESens\\_Dashboard\\_08\\_22\\_22\\_TPD\\_v2.xlsx](https://files.cpuc.ca.gov/energy/modeling/BusbarMapping_30MMT_HESens_Dashboard_08_22_22_TPD_v2.xlsx) (See tab labeled "2\_Tx\_Calculator")

<sup>16</sup> [https://www.cpuc.ca.gov/-/media/cpuc-website/divisions/energy-division/documents/integrated-resource-plan-and-long-term-procurement-plan-irp-ttp/2022-irp-cycle-events-and-materials/busbardashboard2035\\_30mmt\\_hebase\\_vd\\_02-22-23.xlsx](https://www.cpuc.ca.gov/-/media/cpuc-website/divisions/energy-division/documents/integrated-resource-plan-and-long-term-procurement-plan-irp-ttp/2022-irp-cycle-events-and-materials/busbardashboard2035_30mmt_hebase_vd_02-22-23.xlsx)

Table F.4-3: FCDS transmission capability estimates exceedances

Transmission Constraint	Existing System FCDS Capability (MW)**	FCDS Capability Exceedance (Higher of HSN or SSN) (MW)		
		Current TPP 2032 Base	Current TPP 2035 Sensitivity	2023-24 TPP 2035 Base
<b>PG&amp;E Greater Bay and North of Greater Bay Area</b>				
Humboldt–Trinity 115 kV	21	--	32	145
Cortina–Vaca Dixon 230 kV	454	446	1774	2213
Rio Oso-SPI-Lincoln 115 kV	96*	--	42	--
Woodland-Davis 115 kV Line	64	--	71	--
Contra Costa-Delta 230kV Line	1523	--	279	641
Humboldt Offshore Wind constraint	0*	--	1487	1446
<b>PG&amp;E Greater Fresno Area</b>				
Gates 500/230kV Bank #13 Constraint	3151	--	1112	598
Los Banos 500/230kV with Manning Substation***	1573*	--	930	1155
Wilson-Storey-Borden 230 kV	113	72	869	1109
Tesla-Westley 230 kV Constraint	1098	--	361	339
Las Aguillas-Panoche 230 kV	334*	20	1149	783
Los Banos—Gates #1 500 kV Line Constraint	1265*	--	3175	2683
Moss Landing–Los Banos 230 kV Constraint	1611*	--	3290	2885
Warnerville-Wilson 230 kV	272*	76	1182	909
Moss Landing—Las Aguillas 230 kV Constraint	316*	38	1257	1009
<b>PG&amp;E Kern Area</b>				
Midway – Gates 230 kV Line	1431	--	1793	1507
Kern-Lamont-Stockdale 115 kV	100*	--	198	--
Morro Bay-Templeton 230kV	1708	--	2383	2118
<b>East of Pisgah Area</b>				
Eldorado 500/230 kV Transformer #5 Constraint	3360	--	144	--
GLW-VEA Area Constraint***	1300*	240	1676	1058
Mohave/Eldorado 500 kV Default Constraint	1560*	166	745	1326
<b>SCE Northern Area</b>				
Antelope – Vincent 500 kV Constraint	4040	--	831	822
<b>SCE North of Lugo</b>				
Kramer to Victor Area 230 kV Constraint	826	441	536	355
Victor to Lugo 230 kV Constraint	1156	180	440	86
Lugo 500/230 kV Transformer Constraint	1576	20	530	23
<b>SCE Eastern Area</b>				
Colorado River 500/230 kV Constraint	1490	--	--	175
Devers – Red Bluff 500 kV Constraint	5400	--	1821	2163
Serrano – Alberhill – Valley 500 kV Constraint	5700	1671	4119	4932
<b>SDG&amp;E Area</b>				
East of Miguel Area Constraint	731	388	459	397
Encina-San Luis Rey Constraint	1000	1343	1771	1888
Internal San Diego Constraint	968	1021	1326	1217
San Luis Rey-San Onofre Constraint	1500	843	1271	1388

\* Capability estimates marked with an asterisk (\*) default rather than actual limits and reflect the amount of resources studied in the Cluster 13 deliverability studies because binding constraints were not identified.

\*\* Capability values highlighted in green indicate updated values by CPUC based on the 2021-2022 TPP report.

\*\*\* Capability value includes incremental capability due to approved transmission projects in 2021-2022 transmission plan.

Table F.4-4: EODS transmission capability estimate exceedances

Transmission Constraint	Existing System EODS Capability (MW)**	EODS Capability Exceedance (MW)		
		Current TPP 2032 Base	Current TPP 2035 Sensitivity	Proposed Decision (PD) 2023-24 TPP 2035 Base
<b>PG&amp;E Greater Bay and North of Greater Bay Area</b>				
Humboldt – Trinity 115 kV Constraint	63*	37	98	99
Woodland – Davis 115 kV Constraint	64*	--	6	--
Humboldt Offshore Wind constraint	0*	--	1487	1446
<b>PG&amp;E Kern Area</b>				
Morro Bay – Templeton 230 kV	1903*	--	10	388
<b>PG&amp;E Greater Fresno Area</b>				
Las Aguilas-Panoche 230 kV	516	--	256	--
Moss Landing – Las Aguilas 230 kV	0	377	777	314
<b>East of Pisgah Area</b>				
GLW/VEA Area Constraint***	1379*	--	244	--
Mohave/Eorado 500 kV Default Constraint	1560*	--	384	518
<b>SDG&amp;E Area</b>				
East of Miguel Constraint	950	--	--	201

\* Capability estimates marked with an asterisk (\*) default rather than actual limits and reflect the amount of resources studied in the deliverability studies used in developing the transmission capability estimates because binding constraints were not identified.

\*\* Capability values highlighted in green indicate updated values by CPUC based on the 2021-2022 TPP report.

\*\*\* Capability value includes incremental capability due to approved transmission projects in 2021-2022 transmission plan.

## F.5 On-Peak Deliverability Assessment

The primary objective of the policy-driven on-peak deliverability assessment is to support deliverability of the renewable generation and energy storage resources that are identified in the portfolios as requiring FCDS status so they can count towards meeting resource adequacy needs. The assessment evaluates whether the net resource output from a given area can be simultaneously transferred to the remainder of the ISO Control Area during periods of peak system load. The on-peak deliverability assessment of the base and sensitivity portfolios is used to:

- Assess deliverability of FCDS portfolio resources in accordance with the on-peak deliverability assessment methodology;<sup>17</sup>
- Identify transmission upgrades or other solutions needed to ensure deliverability of FCDS renewable portfolio resources; and

<sup>17</sup> <http://www.caiso.com/Documents/On-PeakDeliverabilityAssessmentMethodology.pdf>



- Gain further insights regarding transmission capability, transmission upgrade requirements, etc. to inform future portfolio development.

### **F.5.1 On-peak deliverability assessment assumptions**

The deliverability assessment is performed under two distinct system conditions – the highest system need (HSN) scenario and the secondary system need (SSN) scenario. The HSN scenario represents the period when the capacity shortage is most likely to occur. In this scenario, the system reaches peak sale with low solar output. The highest system need hours represent the hours ending 19 to 22 in the summer months.

The secondary system need scenario represents the period when capacity shortage risk increases if variable resources are not deliverable during periods when the system depends on their high output for resource adequacy. In this scenario, the system load is modeled to represent the peak consumption level and solar output is modeled at a significantly higher output. The secondary system need hours are hours ending 15 to 18 in the summer months.

The ISO performed the on-peak deliverability assessment for both HSN and SSN scenarios. For each scenario and each portfolio, the ISO developed a master on-peak deliverability assessment base case that modeled all FCDS portfolio resources. Key assumptions of the deliverability assessment are described below.

#### **Transmission**

The ISO modeled the same transmission system as in the 2032 peak load base case that is used in the reliability assessment performed as part of the current transmission planning process.

#### **System load**

The ISO modeled the coincident 1-in-5 year peak for the ISO balancing authority area load in the HSN base case. Pump load was dispatched within the expected range for summer peak load hours. The load in the SSN base case was adjusted from HSN to represent the net customer load at the time of forecasted peak consumption.

#### **Maximum resource output (Pmax) assumptions**

Pmax in the on-peak deliverability assessment represents the resource-type specific maximum resource output assumed in the deliverability assessment. For non-intermittent resources, the same Pmax is used in the HSN and SSN scenarios. The most recent summer peak NQC is used as Pmax for existing non-intermittent generating units. For proposed FCDS non-intermittent generators that do not have NQC, the Pmax is set according to the interconnection request. For non-intermittent generic portfolio resources, the FCDS capacity provided in the portfolio is used as the Pmax. For FCDS energy storage resources, the Pmax in the HSN scenario is set to the 4-hour discharging capacity, limited by the requested maximum output from the resource, if applicable. Pmax for energy storage in the SSN scenario is set at half of the HSN value. For FCDS hybrid projects, the study amount for each technology is first calculated separately. Then the total study amount among all technologies is calculated as the sum of the study amount for each technology, but limited by the requested maximum output of the generation project.

FCDS intermittent resources are modeled in the HSN scenario based on the output profiles during the highest system need hours with low unloaded capacity levels. A 20% exceedance production level for wind and solar resources during these hours sets the Pmax tested in the HSN deliverability assessment. In the SSN scenario, intermittent resources are modeled based on the output profiles during the secondary system need hours with low unloaded capacity levels. 50% exceedance production level for wind and solar resources during those hours sets the Pmax tested in the SSN deliverability assessment.

The maximum resource output (Pmax) assumptions used in the HSN and SSN deliverability assessment for FCDS resources are shown in Table F.5-1. For resources with partial deliverability status (PCDS), the Pmax amounts in the table are derated by the deliverable percentage.

Table F.5-1: Maximum FCDS resource output tested in the deliverability assessment

Area	HSN			SSN		
	SDG&E	SCE	PG&E	SDG&E	SCE	PG&E
Solar	3.0%	10.6%	10.0%	40.2%	42.7%	55.6%
Wind	33.7%	55.7%	66.5%	11.2%	20.8%	16.3%
New Mexico Wind	67%			35%		
Wyoming Wind	67%			35%		
Idaho Wind	67%			35%		
Diablo OSW	100%			37%		
Morro Bay OSW	100%			49%		
Humboldt Bay OSW	100%			53%		
Energy Storage	100% or 4-hour equivalent if duration is < 4-hour			50% or 4-hour equivalent if duration is < 4-hour		
Non-Intermittent resources	NQC or 100%					

**Import Levels**

For the HSN scenario, the net scheduled imports at all branch groups as determined in the 2022 annual Maximum Import Capability (MIC) assessment set the imports in the study. Approved MIC expansions and portfolio resources outside the ISO BAA were added to the import levels. Historically unused Existing Transmission Contracts (ETC’s) crossing control area boundaries were modeled as zero MW injections at the tie point, but available to be turned on at remaining contract amounts for screening analysis.

For the SSN scenario, the hour with the highest total net imports among all secondary system need hours from the 2022 MIC assessment data is selected. Net scheduled imports for the hour set the imports in the study. Approved MIC expansions and portfolio resources outside the ISO BAA are added to the import levels.

## F.5.2 General On-peak deliverability assessment procedure

The main steps of the California ISO on-peak deliverability assessment procedure are described below.

### Screening for Potential Deliverability Problems Using DC Power Flow Tool

A DC transfer capability/contingency analysis tool is used to identify potential deliverability problems. For each analyzed facility, an electrical circle is drawn which includes all generating units including unused Existing Transmission Contract (ETC) injections that have a 5% or greater:

$$\text{Distribution factor (DFAX)} = (\Delta \text{ flow on the analyzed facility} / \Delta \text{ output of the generating unit}) * 100\%$$

or

$$\text{Flow impact} = (\text{DFAX} * \text{Full Study Amount} / \text{Applicable rating of the analyzed facility}) * 100\%.$$

Load flow simulations are performed, which study the worst-case combination of generator output within each 5% Circle.

### Verifying and Refining the Analysis Using AC Power Flow Tool

The outputs of capacity units in the 5% Circle are increased starting with units with the largest impact on the transmission facility. No more than 20 units are increased to their maximum output. In addition, no more than 1,500 MW of generation is increased. All remaining generation within the Control Area is proportionally displaced, to maintain a load and resource balance.

When the 20 units with the highest impact on the facility can be increased more than 1,500 MW, the impact of the remaining amount of generation to be increased is considered using a Facility Loading Adder. The Facility Loading Adder is calculated by taking the remaining MW amount available from the 20 units with the highest impact multiplied by the DFAX of each unit. An equivalent MW amount of generation with negative DFAX is also included in the Facility Loading Adder, up to 20 units. If the net impact from the Facility Loading Adders is negative, the impact is set to zero and the flow on the analyzed facility without applying Facility Loading Adders is reported.

The ISO has its on-peak deliverability assessment simulation procedure implemented in PowerGem's Transmission Adequacy & Reliability Assessment (TARA) software. The ISO Deliverability Assessment module in TARA was used to perform the policy-driven on-peak deliverability assessment.

The Base and sensitivity portfolios were studied as part of the 2022-2023 transmission planning process policy-driven, on-peak deliverability assessment. Three delivery point alternatives were considered for Humboldt OSW in the sensitivity portfolio as described in the PG&E area assessment.

Potential mitigation options considered to address on-peak deliverability constraints include Remedial Action Schemes (RAS), reduction of energy storage behind the constraints and transmission upgrades.

## F.6 Off-Peak Deliverability assessment

The ISO modified its on-peak deliverability assessment to reflect the changing contribution of solar to meeting resource adequacy needs. Additional solar resources provide a much lower incremental resource adequacy benefit to the system than the initial solar resources, because their output profile ceases to align with the peak hour of demand on the transmission system which has shifted to later in the day due to the proliferation of behind-the-meter solar. As a result, there is a reduced need for transmission upgrades to support deliverability of additional solar resources for resource adequacy purposes. Generation developers have been relying on transmission upgrades required under the previous on-peak deliverability assessment methodology to ensure that generation would not be exposed to excessive curtailment due to transmission limitations. Therefore, the off-peak deliverability assessment methodology<sup>18</sup> was developed to address renewable energy delivery during hours outside of the summer peak load period to ensure some minimal level of protection from otherwise potentially unlimited curtailment.

Accordingly, the key objectives of the policy-driven off-peak deliverability assessment are to:

- Identify transmission constraints that would cause excessive renewable curtailment in accordance with the off-peak deliverability methodology
- Identify potential transmission upgrades and other solutions needed to relieve excessive renewable curtailment
- Provide the constraints and the identified transmission upgrades as candidates for a more thorough evaluation using production cost simulation

### F.6.1 Off-peak deliverability assessment methodology

The general system study conditions are intended to capture a reasonable scenario for the load, generation, and imports that stress the transmission system, but not coinciding with an oversupply situation. By examining the renewable curtailment data from 2018, a load level of about 55% to 60% of the summer peak load and an import level of about 6000 MW was selected for the off-peak deliverability assessment.

The production of wind and solar resources under the selected load and import conditions varies widely. The production duration curves for solar and wind were examined. The production level under which 90% of the annual energy was selected to set the outputs to be tested in the off-peak deliverability assessment. The dispatch of the remaining generation fleet is set by examining historical production associated with the selected renewable production levels. The hydro dispatch is about 30% of the installed capacity and the thermal dispatch is about 15%. All energy storage facilities are assumed offline.

The dispatch assumptions discussed above apply to both full capacity and energy-only resources. However, depending on the amount of generation in the portfolio, it may be impossible to balance load and resources under such conditions with all portfolio generation dispatched. The dispatch assumptions are applied to all existing, under-construction and

---

<sup>18</sup> <http://www.caiso.com/Documents/Off-PeakDeliverabilityAssessmentMethodology.pdf>

contracted generators first, then some portfolio generators if needed to balance load and resources. This establishes a system-wide dispatch base case or master base case that is the starting case for developing each of the study area base cases to be used in the off-peak deliverability assessments. Table F.6-1 summarizes the generation dispatch assumptions in the master base case.

Table F.6-1: ISO System-Wide Generator Dispatch Assumptions

	Dispatch Level
Wind	44%
Solar	68%
Battery storage	0
Hydro	30%
Thermal	15%

The off-peak deliverability assessment is performed for each study area separately. The study areas in general are the same as the reliability assessment areas in the generation interconnection studies.

Study area base cases are created from the system-wide dispatch base case. All generators in the study area, existing or future, are dispatched to a consistent output level. In order to capture local curtailment, the renewable dispatch is increased to the 90% energy level for the study area, which is higher than the system-wide 90% energy level. The study area 90% energy level was determined from representing individual plants in different areas. For out-of-state and off-shore wind, the dispatch values are based on data obtained from NREL for the PCM model.

If the renewables inside the study area are predominantly wind resources (more than 70% of total study area capacity), wind resource dispatch is increased as shown in Table F.6-2. All the solar resources in the wind pocket are dispatched at the system-wide level of 68%. If the renewables inside the study area are not predominantly wind resources, then the dispatch assumptions in Table F.6-3 are used. The dispatch assumptions for out-of-state and off-shore wind used in the current study are provided in Table F.6-4.

Table F.6-2: Local Area Solar and Wind Dispatch Assumptions in Wind Area

	Wind Dispatch Level	Solar Dispatch Level
SDG&E	69%	68%
SCE	64%	
PG&E	63%	

Table F.6-3: Local Area Solar and Wind Dispatch Assumptions in Solar Area

	Solar Dispatch Level	Wind Dispatch Level
SDG&E	79%	44%
SCE	77%	
PG&E	79%	

Table F.6-4: Additional Local Area Dispatch Assumptions

Resource	Dispatch Level
Offshore Wind	100%
New Mexico Wind	67%
Wyoming Wind	67%

As the generation dispatch increases inside the study area, the following resource adjustment can be performed to balance the loads and resources:

- Reduce new generation outside the study area (staying within the Path 26, 4000 MW north to south, and 3000 MW south to north limits);
- Reduce thermal generation inside the study area;
- Reduce imports; and
- Reduce thermal generation outside the study area.

Once each study area case has been developed, a contingency analysis is performed for normal conditions and selected contingencies:

- Normal conditions (P0);
- Single contingency of transmission circuit (P1.2), transformer (P1.3), single pole of DC lines (P1.5) and two poles of PDCI if impacting the study area; and
- Multiple contingency of two adjacent circuits on common structures (P7.1) and loss of a bipolar DC line (P7.2).

For overloads identified under such dispatch, resources that can be re-dispatched to relieve the overloads are adjusted to determine if the overload can be mitigated:

- Existing energy storage resources are dispatched to their full four-hour charging capacity to relieve the overload;
- Thermal generators contributing to the overloads are turned off; and
- Imports contributing to the overloads are reduced to the level required to support out-of-state renewables in the RPS portfolios.

The remaining overloads after the re-dispatch will be mitigated by the identification of transmission upgrades or other solutions. Generators with 5% or higher distribution factor (DFAX) on the constraint are considered contributing generators. The distribution factor is the percentage of a particular generation unit's incremental increase in output that flows on a particular transmission line or transformer under the applicable contingency condition when the displaced generation is spread proportionally, across all dispatched resources available to scale down output proportionally. Generation units are scaled down in proportion to the dispatch level of the unit.

The base and sensitivity portfolios were studied as part of the 2022-2023 transmission planning process policy-driven off-peak deliverability assessment. Three delivery point alternatives were considered for Humboldt OSW in the sensitivity portfolio as described in the PG&E area assessment.

The potential solutions considered to address off-peak deliverability constraints include Remedial Action Schemes (RAS), dispatching available battery storage behind the constraints, adding energy storage behind the constraints (subject to on-peak deliverability) and transmission upgrades.

## F.7 PG&E Greater Bay and North of Greater Bay Interconnection Area

The total capacity of resources, by resource type, selected with Full Capacity Deliverability Status (FCDS) as well as those selected as Energy Only (EO) in the PG&E Greater Bay and North of Greater Bay interconnection area are listed in Table F.7-1. The portfolios in the interconnection area are comprised of solar, wind (in-state and offshore), battery storage, geothermal, biomass/biogass and distributed solar resources. All portfolio resources are modeled in policy-driven assessments except in the on-peak deliverability assessment in which only FCDS resources are modeled.

Table F.7-1: PG&E Greater Bay and North of Greater Bay Interconnection Area – Base and Sensitivity Portfolios by Resource Types (FCDS, EO and Total)

Resource Type	Base Portfolio			Sensitivity Portfolio		
	FCDS (MW)	EO (MW)	Total (MW)	FCDS (MW)	EO (MW)	Total (MW)
Solar	-	-	-	344	1,512	1,856
Wind – In State	577	499	1,076	626	546	1,172
Wind – Out-of-State (Existing TX)	-	-	-	-	-	-
Wind – Out-of-State (New TX)	-	-	-	-	-	-
Wind – Offshore	-	120	120	1,487	120	1,607
Li Battery	607	-	607	2,198	-	2,198
Geothermal	79	-	79	119	-	119
Long Duration Energy Storage (LDES)	-	-	-	-	-	-
Biomass/Biogass	95	-	95	95	-	95
Distributed Solar	64	-	64	64	-	64
<b>Total</b>	<b>1,422</b>	<b>619</b>	<b>2,041</b>	<b>4,933</b>	<b>2,178</b>	<b>7,111</b>

The resources as identified in the CPUC busbar mapping for the PG&E Greater Bay and North of Greater Bay interconnection area are illustrated on the single-line diagram in Figure F.7-1. No adjustments were made to the portfolios in this area to account for allocated TPD and additional in-development resources identified.



Figure F.7-1: Greater Bay and North of Greater Bay Interconnection Area – Mapped Base Portfolio

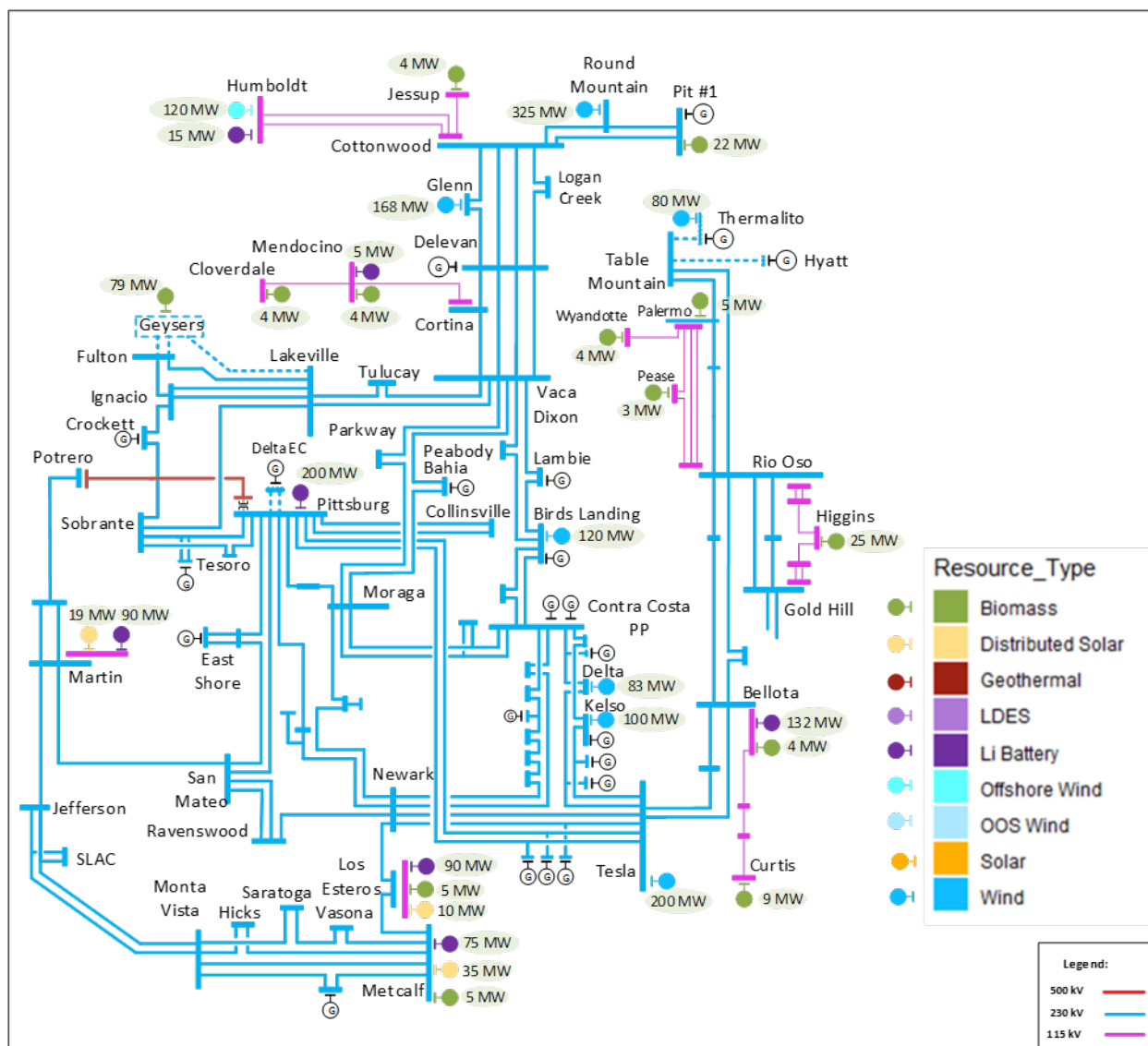

With the resource mix specified in Table F.7.1-1 modeled in the base cases, the On-Peak deliverability assessment identified the following constraints in PG&E study areas:

### F.7.1 On-peak results

#### Collinsville – Pittsburg E 230 kV lines on-peak deliverability constraint

The deliverability of renewable portfolio resources in the Northern California area is limited by thermal overloading of the Collinsville – Pittsburg E #1 230 kV line under N-1 conditions as shown in Table F.7-2. This constraint was identified in baseline portfolio under HSN conditions. As shown in Table F.7-3, 0 MW of renewable and energy storage would be deliverable without any transmission upgrades. The constraint can be mitigated by reducing the overall series compensation on the Table Mountain-Vaca-Collinsville-Tesla 500 kV path.

Table F.7-2: Collinsville – Pittsburg E 230 kV line on-peak deliverability constraint

Overloaded Facility	Contingency	Scenario	Loading	
			BASE	SENS-01
Collinsville – Pittsburg E 230 kV Line	Collinsville – Pittsburg F 230 kV	HSN	106	138

Table F.7-3: Collinsville – Pittsburg E 230 kV line on-peak deliverability constraint summary

Affected transmission zones		Base	Sensitivity
Generic Portfolio MW behind the constraint (installed FCDS capacity)		40	1527
Generic Battery storage portfolio MW behind the constraint (installed FCDS capacity)		0	0
Deliverable Generic Portfolio MW w/o mitigation (Installed FCDS capacity)		0	0
Total undeliverable baseline and portfolio MW (Installed FCDS capacity)		1342	2629
Mitigation Options	RAS	NA	NA
	Re-locate generic portfolio battery storage (MW)	NA	NA
	Transmission upgrade including cost	None	None
Recommended Mitigation		Reduce the overall series compensation on the Table Mountain-Vaca-Collinsville-Tesla 500 kV path.	

**Cloverdale – Eagle Rock 115 kV line on-peak deliverability constraint**

The deliverability of renewable portfolio resources in the Northern California area is limited by thermal overloading of the Cloverdale – Eagle Rock 115 kV line under N-2 conditions as shown in Table F.7-4. This constraint was identified in baseline portfolio under HSN conditions. As shown in Table F.7-5, 41 MW of renewable and energy storage would be deliverable without any transmission upgrades. The constraint can be mitigated by moving the modeling of portfolio resource to a higher kV level.

Table F.7-4: Cloverdale – Eagle Rock 115 kV line on-peak deliverability constraint

Overloaded Facility	Contingency	Scenario	Loading	
			BASE	SENS-01
Cloverdale – Eagle Rock 115 kV	Geysers #3-Eagle Rock & Geysers #7-Eagle Rock 115 kV lines	HSN	125	120

Table F.7-5: Cloverdale – Eagle Rock 115 kV line on-peak deliverability constraint summary

Affected transmission zones			
		Base	Sensitivity
Generic Portfolio MW behind the constraint (installed FCDS capacity)		79	0
Generic Battery storage portfolio MW behind the constraint (installed FCDS capacity)		0	0
Deliverable Generic Portfolio MW w/o mitigation (Installed FCDS capacity)		41	0
Total undeliverable baseline and portfolio MW (Installed FCDS capacity)		38	264
Mitigation Options	RAS	NA	NA
	Re-locate generic portfolio battery storage (MW)	NA	NA
	Transmission upgrade including cost	None	None
Recommended Mitigation		Move the modeling of portfolio resource to a higher kV level.	

**Eagle Rock- Fulton- Silverado 115 kV (Eagle rock sub to Ricon Jct 115 kV) line on-peak deliverability constraint**

The deliverability of renewable portfolio resources in the Northern California area is limited by thermal overloading of the Eagle Rock- Fulton- Silverado 115 kV (Eagle Rock sub to Ricon Jct 115 kV) line under N-2 conditions as shown in Table F.7-6. This constraint was identified in baseline portfolio under HSN conditions. As shown in Table F.7-7, 114 MW of renewable and energy storage would be deliverable without any transmission upgrades. The constraint will be continued to be monitored as is was is not identified in the sensitivity portfolio.

Table F.7-6: Eagle Rock- Fulton- Silverado 115 kV (Eagle rock sub to Ricon Jct 115 kV) line on-peak deliverability constraint

Overloaded Facility	Contingency	Scenario	Loading	
			BASE	SENS-01
Eagle Rock- Fulton- Silverado 115 kv (Eagle rock sub to Ricon Jct 115 kV)	Vaca- Lakeville #1 & Tulucay - Vaca 230 kV lines	HSN	105	<100%

Table F.7-7: Eagle Rock- Fulton- Silverado 115 kV (Eagle rock sub to Ricon Jct 115 kV) line on-peak deliverability constraint summary

Affected transmission zones		Base	Sensitivity
Generic Portfolio MW behind the constraint (installed FCDS capacity)		133	NA
Generic Battery storage portfolio MW behind the constraint (installed FCDS capacity)		5	NA
Deliverable Generic Portfolio MW w/o mitigation (Installed FCDS capacity)		114	NA
Total undeliverable baseline and portfolio MW (Installed FCDS capacity)		24	NA
Mitigation Options	RAS	NA	NA
	Re-locate generic portfolio battery storage (MW)	NA	NA
	Transmission upgrade including cost	None	None
Recommended Mitigation		Continue to Monitor	

**Humboldt Bay Area 60 kV on-peak deliverability constraint**

The deliverability of renewable portfolio resources in the Northern California area is limited by thermal overloading of several lines in the Humboldt 60 kV area under Basecase conditions as shown in Table F.7-8. This constraint was identified in baseline portfolio under HSN conditions. As shown in Table F.7-9, 0 MW of renewable and energy storage would be deliverable without any transmission upgrades. The constraint can be mitigated by Garberville Area Reinforcement reliability project recommended for approval in this cycle.

Table F.7-8: Humboldt Bay Area 60 kV on-peak deliverability constraint

Overloaded Facility	Contingency	Scenario	Loading	
			BASE	SENS-01
Humboldt Bay Area 60 kV	Basecase	HSN	117	154

Table F.7-9: Humboldt Bay Area 60 kV on-peak deliverability constraint summary

Affected transmission zones			
		Base	Sensitivity
Generic Portfolio MW behind the constraint (installed FCDS capacity)		0	0
Generic Battery storage portfolio MW behind the constraint (installed FCDS capacity)		15	15
Deliverable Generic Portfolio MW w/o mitigation (Installed FCDS capacity)		0	0
Total undeliverable baseline and portfolio MW (Installed FCDS capacity)		71	240
Mitigation Options	RAS	NA	NA
	Re-locate generic portfolio battery storage (MW)	NA	NA
	Transmission upgrade including cost	None	None
Recommended Mitigation		Garberville Area Reinforcement reliability project recommended for approval in this cycle.	

**Cortina No. 4 60 kV Line on-peak deliverability constraint**

The deliverability of renewable portfolio resources in the Northern California area is limited by thermal overloading of the Cortina No. 4 60 kV line under Basecase conditions as shown in Table F.7-10. This constraint was identified in baseline portfolio under HSN conditions. As shown in Table F.7-11, 42 MW of renewable and energy storage would be deliverable without any transmission upgrades. The constraint can be mitigated by moving the modeling of portfolio resource to a higher kV level.

Table F.7-10: Cortina No. 4 60 kV Line on-peak deliverability constraint

Overloaded Facility	Contingency	Scenario	Loading	
			BASE	SENS-01
Cortina No. 4 60 kV Line	Basecase	HSN	120	<100%

Table F.7-11: Cortina No. 4 60 kV Line on-peak deliverability constraint summary

Affected transmission zones		Base	Sensitivity
Generic Portfolio MW behind the constraint (installed FCDS capacity)		50	NA
Generic Battery storage portfolio MW behind the constraint (installed FCDS capacity)		0	NA
Deliverable Generic Portfolio MW w/o mitigation (Installed FCDS capacity)		42	NA
Total undeliverable baseline and portfolio MW (Installed FCDS capacity)		8	NA
Mitigation Options	RAS	NA	NA
	Re-locate generic portfolio battery storage (MW)	NA	NA
	Transmission upgrade including cost	None	None
Recommended Mitigation		Move the modeling of portfolio resource to a higher kV level	

The constraints identified in Table F.7-12 were only observed in the sensitivity portfolio and not in the base portfolio. Potential mitigation has been identified for further assessment in the 2023-2024 planning cycle. For the North Dublin-Vinyard 230 kV constraint, the reliability-driven project identified in Chapter 2 as the Lone Tree – Cayetano – Newark Corridor Series Compensation project will mitigate the identified constraint.

Table F.7-12: Greater Bay and North of Greater Bay Interconnection Area On-Peak Deliverability Constraints in only the Sensitivity Portfolio

Constraint	Portfolio	Generic Portfolio MW behind the constraint	Generic Battery storage portfolio MW behind the constraint	Deliverable Generic Portfolio MW w/o mitigation	Total undeliverable baseline and portfolio MW	Potential Mitigation
East Shore – San Mateo 230 kV line	Sensitivity	828	400	781	446	Reduce the overall series compensation on the Table Mountain-Vaca-Collinsville-Tesla 500 kV.
North Dublin – Vineyard 230 kV line	Sensitivity	0	150	121	28	Contra Costa - Lone Tree Series compensation TPP project
Lincoln - Pleasant Grove 115 kV Line	Sensitivity	0	127	5	122	Possible RAS or Reconductor
Stanislaus-Melones-Manteca 115 kV Line No.1	Sensitivity	0	287	201	86	Reconductor
Drum – Higgins 115 kV	Sensitivity	0	0	0	34	Reconductor

### F.7.2 Off-peak results

In the off-peak deliverability assessment of the Greater Bay and North of Greater Bay interconnection there were no constraints identified for the base portfolios. The constraints that were observed in the sensitivity portfolio only are listed in Table F.7-13. Potential mitigation has been identified for further assessment in the 2023-2024 planning cycle.

Table F.7-13: Greater Bay and North of Greater Bay Interconnection Area On-Peak Deliverability Constraints in only the Sensitivity Portfolio

Constraint	Portfolio	Renewable Portfolio MW behind Constraint	Energy Storage Portfolio MW behind Constraint	Renewable curtailment without mitigation	Potential Mitigation
Midway-Gates 500 kV line	Sensitivity	6,964	2,279	1,748	Portfolio energy storage in charging mode
Moss Landing-Los Banos 500 kV line	Sensitivity	13,284	5,466	4,729	Portfolio energy storage in charging mode
Belridge J-Pumpjack Tp	Sensitivity	55	55	26	Portfolio energy storage in charging mode
Borden-Storey #1/#2 230 kV	Sensitivity	4,264	2,168	2,683	Portfolio energy storage in charging mode
Quinto-Los Banos 230 kV line	Sensitivity	13,394	5,462	4,082	Portfolio energy storage in charging mode.
Gates-Arco 230 kV line	Sensitivity	2,751	1,674	272	Portfolio energy storage in charging mode
Los Banos-Panoche #2 230 kV	Sensitivity	1,569	880	1,040	Portfolio energy storage in charging mode
Schindler-Coalinga #2 70 kV Line (Schindler-Paige Section)	Sensitivity	150	75	93	Portfolio energy storage in charging mode
Tesla-Westley 230 kV line	Sensitivity	5,631	2,839	1,503	Portfolio energy storage in charging mode
Westley-Q1244 SS 230 kV line	Sensitivity	13,394	5,462	3,714	Portfolio energy storage in charging mode
Wilson-Dairyland 115 kV Line	Sensitivity	100	75	62	Portfolio energy storage in charging mode
Arco-Midway 230 kV line	Sensitivity	586	318	181	Portfolio energy storage in charging mode
Gregg - Mustang 230 kV line	Sensitivity	8,891	3,099	1,485	Reconductor if economic
Gates - Manning 500 kV line	Sensitivity	9,604	3,588	4,888	Reconductor or new line if economic.
Panoche 115 kV Area	Sensitivity	150	85	104	Reconductor or new line if economic.
Panoche 230 kV Area	Sensitivity	3,100	1,352	2,361	Reconductor or new line if economic.
Panoche 70 kV Area	Sensitivity	150	75	104	Reconductor or new line if economic.

### F.8 PG&E Greater Fresno Interconnection Area

The total capacity of resources, by resource type, selected with Full Capacity Deliverability Status (FCDS) as well as those selected as Energy Only (EO) in the PG&E Greater Fresno interconnection area are listed in Table F.8-1. The portfolios are comprised of solar, wind (in-state), battery storage, biomass/biogass and distributed solar resources. All portfolio resources are modeled in policy-driven assessments except in the on-peak deliverability assessment in which only FCDS resources are modeled.

Table F.8-1: PG&E Greater Fresno Interconnection Area – Base and Sensitivity Portfolios by Resource Types (FCDS, EO and Total)

Resource Type	Base Portfolio			Sensitivity Portfolio		
	FCDS (MW)	EO (MW)	Total (MW)	FCDS (MW)	EO (MW)	Total (MW)
Solar	447	930	1,377	1,527	3,530	5,057
Wind – In State	285	-	285	285	-	285
Wind – Out-of-State (Existing TX)	-	-	-	-	-	-
Wind – Out-of-State (New TX)	-	-	-	-	-	-
Li Battery	1,003	-	1,003	3,023	-	3,023
Geothermal	-	-	-	-	-	-
Long Duration Energy Storage (LDES)	-	-	-	-	-	-
Biomass/Biogass	15	-	15	15	-	15
Distributed Solar	19	-	19	19	-	19
<b>Total</b>	<b>1,769</b>	<b>930</b>	<b>2,699</b>	<b>4,869</b>	<b>3,530</b>	<b>8,399</b>

The resources as identified in the CPUC busbar mapping for the PG&E Greater Fresno interconnection area are illustrated on the single-line diagram in Figure F.8-1. No adjustments were made to the portfolios in this area to account for allocated TPD and additional in-development resources identified. Adjustments

Figure F.8-1: PG&E Greater Fresno Interconnection Area – Mapped Base Portfolio

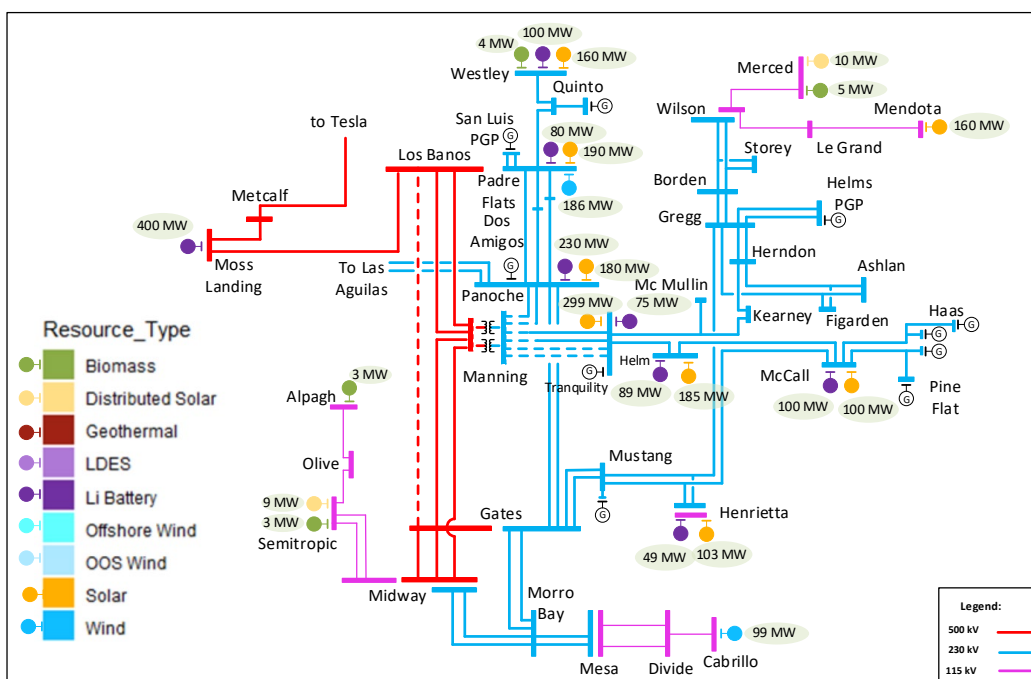



**F.8.1 On-peak results**

**Borden - Storey #1 and #2 230 kV lines on-peak deliverability constraint**

The deliverability of renewable portfolio resources in the Northern California area is limited by thermal overloading of the Borden - Storey #1 and #2 230 kV lines under N-1 conditions as shown in Table F.8-2. This constraint was identified in baseline portfolio under HSN conditions. As shown in Table F.8-3, 0 MW of renewable and energy storage would be deliverable without any transmission upgrades.

Table F.8-2: Borden - Storey #1 and #2 230 kV lines on-peak deliverability constraint

Overloaded Facility	Contingency	Scenario	Loading	
			BASE	SENS-01
Borden - Storey #1 or #2 230 kV line	Borden - Storey #2 or #1 230 kV line	HSN	112	150

Table F.8-3: Borden - Storey #1 and #2 230 kV lines on-peak deliverability constraint summary

Affected transmission zones			
		Base	Sensitivity
Generic Portfolio MW behind the constraint (installed FCDS capacity)		18	79
Generic Battery storage portfolio MW behind the constraint (installed FCDS capacity)		139	2168
Deliverable Generic Portfolio MW w/o mitigation (Installed FCDS capacity)		0	0
Total undeliverable baseline and portfolio MW (Installed FCDS capacity)		581	2689
Mitigation Options	RAS	Not feasible	Not feasible
	Re-locate generic portfolio battery storage (MW)	NA	NA
	Transmission upgrade including cost	Reconductor (\$25.24-\$50.48M)	Reconductor (\$25.24-\$50.48M)
Recommended Mitigation		Borden-Storey 230 kV lines reconductoring project	

To address overloads identified in the base and sensitivity portfolios the ISO is recommending approval of reconductoring the Borden – Storey section(s) of the Wilson – Storey #1 and #2 230 kV lines. RAS was considered as an alternative but was not selected due to not meeting the RAS guidelines. Series compensation was also considered as an alternative but was not selected due to the size that would be needed to mitigate the overload. The estimated project cost is between \$25 million and \$50 million and is expected to be in-service before 2032.

Figure F.8-2: Borden-Storey 230 kV lines reconductoring project

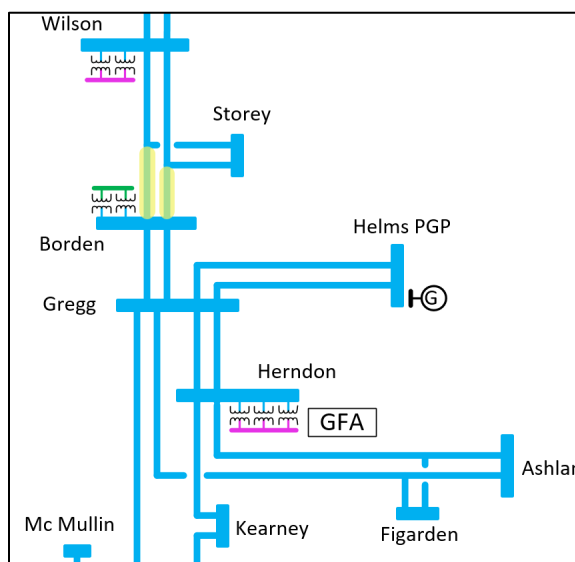

**Henrietta 230/115 kV Bank 3 on-peak deliverability constraint**

The deliverability of renewable portfolio resources in the Fresno area is limited by thermal overloading of the Henrietta 230/115 kV Bank 3 under N-2 conditions as shown in Table F.8-4. This constraint was identified in baseline portfolio under HSN conditions. As shown in Table F.8-5, 0 MW of renewable and energy storage would be deliverable without any transmission upgrades. To address overloads identified in the base and sensitivity portfolios the ISO is recommending approval of reconductoring the Henrietta 230/115 kV Bank 3. RAS was considered as an alternative but was not selected due to not meeting the RAS guidelines. The estimated project cost is between \$12 million and \$20 million and is expected to be in-service before 2032.

Figure F.8-3: Henrietta 230/115 kV Bank 3 replacement project

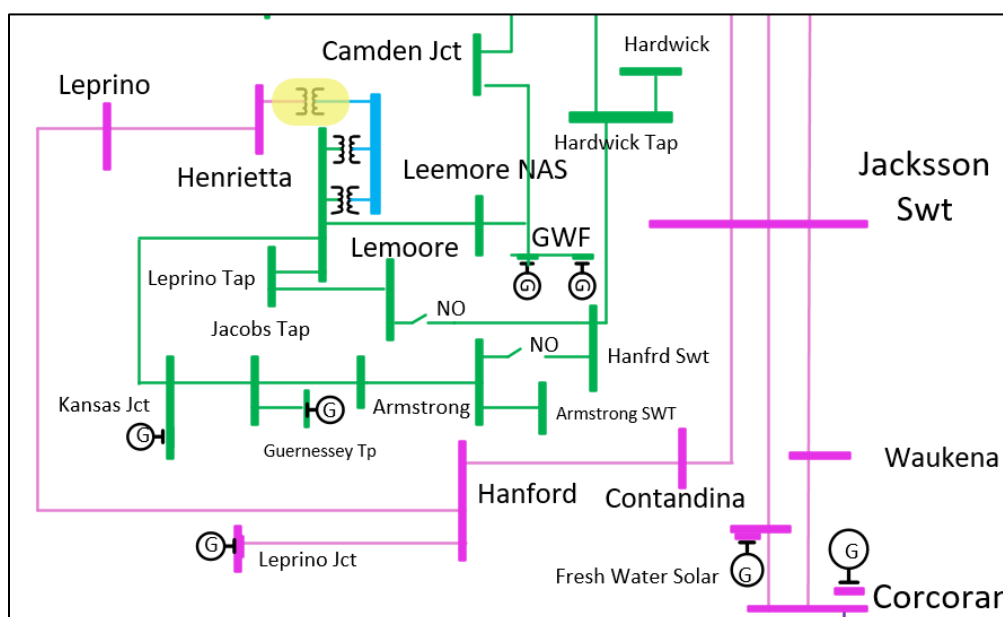

Table F.8-4: Henrietta 230/115 kV Bank 3 on-peak deliverability constraint

Overloaded Facility	Contingency	Scenario	Loading	
			BASE	SENS-01
Henrietta 230/115 kV bank	Helm-McCall 230 kV & Hentap2-MustangSS #1 230 kV lines	HSN	103	111

Table F.8-5: Henrietta 230/115 kV Bank 3 on-peak deliverability constraint summary

Affected transmission zones			
		Base	Sensitivity
Generic Portfolio MW behind the constraint (installed FCDS capacity)		0	0
Generic Battery storage portfolio MW behind the constraint (installed FCDS capacity)		0	0
Deliverable Generic Portfolio MW w/o mitigation (Installed FCDS capacity)		0	0
Total undeliverable baseline and portfolio MW (Installed FCDS capacity)		191	300
Mitigation Options	RAS	Not feasible	Not feasible
	Re-locate generic portfolio battery storage (MW)	NA	NA
	Transmission upgrade including cost	Bank replacement (\$12M-\$20M)	Bank replacement (\$12M-\$20M)
Recommended Mitigation		Henrietta 230/115 kV Bank 3 replacement project	

The constraints identified in Table F.8-6 were only observed in the sensitivity portfolio and not in the base portfolio. Potential mitigation has been identified for further assessment in the 2023-2024 planning cycle.

Table F.8-6: PG&E Greater Fresno Interconnection Area On-Peak Deliverability Constraints in only the Sensitivity Portfolio

Constraint	Portfolio	Generic Portfolio MW behind the constraint	Generic Battery storage portfolio MW behind the constraint	Deliverable Generic Portfolio MW w/o mitigation	Total undeliverable baseline and portfolio MW	Potential Mitigation
Las Aguilas – Moss Landing 230 kV line	Sensitivity	3150	880	3155	875	Reevaluate previously approved series reactor on the Moss Landing – Las Aguilas 230 kV line
McCall 115/230 kV Bank 1	Sensitivity	167	509	484	193	RAS or Bank replacement
Gates-Gregg 230 kV Line	Sensitivity	3948	810	3792	1774	Reconductor Line
Melones-Cottle 230 kV line	Sensitivity	18	335	263	90	Reconductor Line
Barton-Airways-Sanger 115 kV line	Sensitivity	0	509	0	940	Reconductor Line
Herndon – Woodward 115 kV line	Sensitivity	3	260	1	262	Reconductor Line
GWF-Kingsburg 115 kV Line	Sensitivity	25	54	0	626	Reconductor Line
Corcoran-Smyrna (Alpaugh-Smyrna) 115 kV line	Sensitivity	23	175	153	45	Reconductor Line

### F.8.2 Off-peak results

#### Kettleman – Gates 70 kV line off-peak deliverability constraint

Wind and solar resources in the Kettleman – Gates 70 kV lines are subject to curtailment in the base and sensitivity portfolios due to loading limitations on the lines as shown in Table F.8-7. These constraints can be mitigated by switching 1 MW of generic battery resource to charging mode.

Table F.8-7: Kettleman – Gates 70 kV line off-peak deliverability constraint

Overloaded Facility	Contingency	Area	Loading	
			BASE	SENS-01
Kettleman – Gates 70 kV line	Basecase	South PG&E	103	<100%

Table F.8-8: Kettlemen – Gates 70 kV line off-peak deliverability constraint summary

Affected renewable transmission zones		Base	Sensitivity
Renewable portfolio MW behind the constraint (installed capacity)		NA	NA
Energy storage (ES) portfolio MW behind the constraint (installed capacity)		10	NA
Renewable curtailment without mitigation (MW) (installed capacity)		1	NA
Mitigation Options:	Portfolio ES (in charging mode) (MW) <sup>[1]</sup>	NA	NA
	RAS	NA	NA
	Additional battery storage (MW)	NA	NA
	Transmission upgrades	NA	NA
Recommended Mitigation		Switch 1 MW of generic battery resources to charging mode	NA

**Warnerville – Wilson 230 kV line off-peak deliverability constraint**

Wind and solar resources in Warnerville – Willison 230 kV lines are subject to curtailment in the base and sensitivity portfolios due to loading limitations on the lines as shown in Table F.8-9. These constraints can be mitigated by switching 80 MW of generic battery resources to charging mode.

Table F.8-9: Warnerville – Willison 230 kV line off-peak deliverability constraint

Overloaded Facility	Contingency	Area	Loading	
			BASE	SENS-01
Warnerville – Willison 230 kV line	Bellota-Cottle 230 kV line	South PG&E	175	151

<sup>[1]</sup> The Portfolio energy storage (in charging mode) amount is the amount needed to mitigate the constraint after baseline battery storage is fully utilized.

Table F.8-10: Wamerville – Wilson 230 kV line off-peak deliverability constraint summary

Affected renewable transmission zones		Base	Sensitivity
Renewable portfolio MW behind the constraint (installed capacity)		398	1,698
Energy storage (ES) portfolio MW behind the constraint (installed capacity)		228	1,098
Renewable curtailment without mitigation (MW) (installed capacity)		1,420	831
Mitigation Options:	Portfolio ES (in charging mode) (MW) <sup>[1]</sup>	80	Not feasible
	RAS	NA	NA
	Additional battery storage (MW)	NA	NA
	Transmission upgrades	NA	NA
Recommended Mitigation		Switch 80 MW of generic battery resources to charging mode	Reconductor

**Los Banos 500 kV off-peak deliverability constraint**

Wind and solar resources Los Banos 500 kV is subject to curtailment in the base and sensitivity portfolios due to loading limitations on the lines as shown in Table F.8-11. These constraints can be mitigated by switching 673 MW of generic battery resources to charging mode.

Table F.8-11: Los Banos 500 kV off-peak deliverability constraint

Overloaded Facility	Contingency	Area	Loading	
			BASE	SENS-01
Los Banos – Manning #1 or #2 500 kV line	Los Banos – Manning #2 or #1 500 kV line	South PG&E	132	191

<sup>[1]</sup> The Portfolio energy storage (in charging mode) amount is the amount needed to mitigate the constraint after baseline battery storage is fully utilized.

Table F.8-12: Los Banos 500 kV off-peak deliverability constraint summary

Affected renewable transmission zones		Base	Sensitivity
Renewable portfolio MW behind the constraint (installed capacity)		3,404	11,858
Energy storage (ES) portfolio MW behind the constraint (installed capacity)		932	4,877
Renewable curtailment without mitigation (MW) (installed capacity)		2,786	7,517
Mitigation Options:	Portfolio ES (in charging mode) (MW) <sup>[1]</sup>	673	Not feasible
	RAS	NA	NA
	Additional battery storage (MW)	NA	NA
	Transmission upgrades	NA	NA
Recommended Mitigation		Switch 673 MW of generic battery resources to charging mode	Adjust series compensation

The constraints identified in Table F.8-13 were only observed in the sensitivity portfolio and not in the base portfolio. Potential mitigation has been identified for further assessment in the 2023-2024 planning cycle.

<sup>[1]</sup> The Portfolio energy storage (in charging mode) amount is the amount needed to mitigate the constraint after baseline battery storage is fully utilized.

Table F.8-13: PG&amp;E Greater Fresno Interconnection Area Off-Peak Deliverability Constraints in only the Sensitivity Portfolio

Constraint	Portfolio	Renewable Portfolio MW behind Constraint	Energy Storage Portfolio MW behind Constraint	Renewable curtailment without mitigation	Potential Mitigation
Midway-Gates 500 kV line	Sensitivity	6,964	2,279	1,748	Portfolio energy storage in charging mode
Moss Landing-Los Banos 500 kV line	Sensitivity	13,284	5,466	4,729	Portfolio energy storage in charging mode
Belridge J-Pumpjack Tp	Sensitivity	55	55	26	Portfolio energy storage in charging mode
Borden-Storey #1/#2 230 kV	Sensitivity	4,264	2,168	2,683	Portfolio energy storage in charging mode
Quinto-Los Banos 230 kV line	Sensitivity	13,394	5,462	4,082	Portfolio energy storage in charging mode.
Gates-Arco 230 kV line	Sensitivity	2,751	1,674	272	Portfolio energy storage in charging mode
Los Banos-Panoche #2 230 kV	Sensitivity	1,569	880	1,040	Portfolio energy storage in charging mode
Schindler-Coalinga #2 70 kV Line (Schindler-Paige Section)	Sensitivity	150	75	93	Portfolio energy storage in charging mode
Tesla-Westley 230 kV line	Sensitivity	5,631	2,839	1,503	Portfolio energy storage in charging mode
Westley-Q1244 SS 230 kV line	Sensitivity	13,394	5,462	3,714	Portfolio energy storage in charging mode
Wilson-Dairyland 115 kV Line	Sensitivity	100	75	62	Portfolio energy storage in charging mode
Arco-Midway 230 kV line	Sensitivity	586	318	181	Portfolio energy storage in charging mode
Gregg - Mustang 230 kV line	Sensitivity	8,891	3,099	1,485	Reconductor if economic
Gates - Manning 500 kV line	Sensitivity	9,604	3,588	4,888	Reconductor or new line if economic.
Panoche 115 kV Area	Sensitivity	150	85	104	Reconductor or new line if economic.
Panoche 230 kV Area	Sensitivity	3,100	1,352	2,361	Reconductor or new line if economic.
Panoche 70 kV Area	Sensitivity	150	75	104	Reconductor or new line if economic.



## F.9 PG&E East Kern Interconnection Area

The total capacity of resources, by resource type, selected with Full Capacity Deliverability Status (FCDS) as well as those selected as Energy Only (EO) in the PG&E East Kern interconnection area are listed in Table F.9-1. The portfolios in the interconnect area are comprised of solar, wind (in-state and offshore), battery storage, biomass/biogas and distributed solar resources. All portfolio resources are modeled in policy-driven assessments except in the on-peak deliverability assessment in which only FCDS resources are modeled.

Table F.9-1: PG&E East Kern Interconnection Area – Base and Sensitivity Portfolios by Resource Types (FCDS, EO and Total)

Resource Type	Base Portfolio			Sensitivity Portfolio		
	FCDS (MW)	EO (MW)	Total (MW)	FCDS (MW)	EO (MW)	Total (MW)
Solar	575	850	1,425	2,008	3,909	5,917
Wind – In State	248	-	248	188	-	248
Wind – Out-of-State (Existing TX)	-	-	-	-	-	-
Wind – Out-of-State (New TX)	-	-	-	-	-	-
Wind – Offshore	1,588	-	1,588	3,100	-	3,100
Li Battery	622	-	622	3,052	-	3,052
Geothermal	-	-	-	-	-	-
Long Duration Energy Storage (LDES)	-	-	-	300	-	300
Biomass/Biogass	5	-	5	5	-	5
Distributed Solar	32	-	32	32	-	32
<b>Total</b>	<b>3,070</b>	<b>850</b>	<b>3,920</b>	<b>8,685</b>	<b>3,909</b>	<b>12,653</b>

The resources as identified in the CPUC busbar mapping for the PG&E East Kern interconnection area are illustrated on the single-line diagram in Figure F.9-1. No adjustments were made to the portfolios in this area to account for allocated TPD and additional in-development resources identified.

Figure F.9-1: PG&E East Kern Interconnection Area – Mapped Base Portfolio

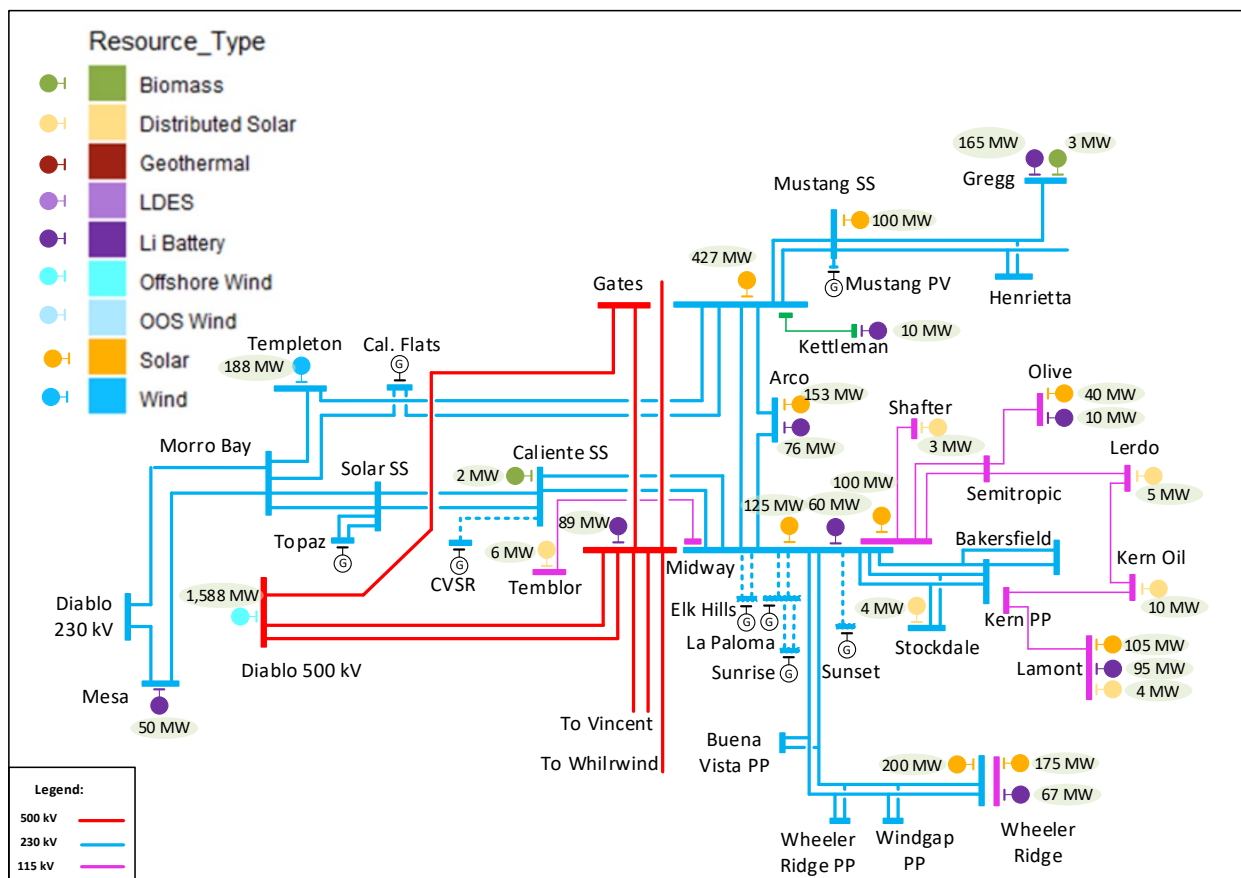

### F.9.1 On-peak results

#### Wheeler 115/70 kV bank 2 on-peak deliverability constraint

The deliverability of renewable portfolio resources in the East Kern area is limited by thermal overloading of the Wheeler 115/70 kV bank 2 under basecase conditions as shown in Table F.9-2. This constraint was identified in baseline portfolio under HSN conditions. As shown in Table F.9-3, 53 MW of renewable and energy storage would be deliverable without any transmission upgrades. The constraint can be mitigated by Wheeler Ridge Junction reliability project recommended to bring out of the on-hold status in this cycle.

Table F.9-2: Wheeler 115/70 kV bank 2 on-peak deliverability constraint

Overloaded Facility	Contingency	Scenario	Loading	
			BASE	SENS-01
Wheeler 115/70 kV bank 2	Basecase	HSN	123	225

Table F.9-3: Wheeler 115/70 kV bank 2 on-peak deliverability constraint summary

Affected transmission zones		Base	Sensitivity
Generic Portfolio MW behind the constraint (installed FCDS capacity)		0	70
Generic Battery storage portfolio MW behind the constraint (installed FCDS capacity)		67	117
Deliverable Generic Portfolio MW w/o mitigation (Installed FCDS capacity)		53	103
Total undeliverable baseline and portfolio MW (Installed FCDS capacity)		14	84
Mitigation Options	RAS	NA	NA
	Re-locate generic portfolio battery storage (MW)	NA	NA
	Transmission upgrade including cost	None	None
Recommended Mitigation		Mitigated by Wheeler Ridge Junction reliability project recommended to bring out of the on-hold status in this cycle.	

**Arco-Cholame 70 kV Line on-peak deliverability constraint**

The deliverability of renewable portfolio resources in the East Kern area is limited by thermal overloading of the Arco-Cholame 70 kV line under basecase conditions as shown in Table F.9-4. This constraint was identified in baseline portfolio under HSN conditions. As shown in Table F.9-5, 31 MW of renewable and energy storage would be deliverable without any transmission upgrades. The constraint can be mitigated by moving the modeling of portfolio resource to a higher kV level.

Table F.9-4: Arco-Cholame 70 kV Line on-peak deliverability constraint

Overloaded Facility	Contingency	Scenario	Loading	
			BASE	SENS-01
Arco-Cholame 70 kV Line	Basecase	HSN	121	<100%

Table F.9-5: Arco-Cholame 70 kV Line on-peak deliverability constraint summary

Affected transmission zones		Base	Sensitivity
Generic Portfolio MW behind the constraint (installed FCDS capacity)		60	NA
Generic Battery storage portfolio MW behind the constraint (installed FCDS capacity)		0	NA
Deliverable Generic Portfolio MW w/o mitigation (Installed FCDS capacity)		31	NA
Total undeliverable baseline and portfolio MW (Installed FCDS capacity)		14	NA
Mitigation Options	RAS	NA	NA
	Re-locate generic portfolio battery storage (MW)	NA	NA
	Transmission upgrade including cost	None	None
Recommended Mitigation		Move the modeling of portfolio resource to a higher kV level.	

### F.9.2 Off-peak results

#### **Kern-Tevis-Stockdale #1/#2 115kV line off-peak deliverability constraint**

Wind and solar resources in the Kern – Tevis – Stockdale #1 and #2 115 kV lines are subject to curtailment in the base and sensitivity portfolios due to loading limitations on the lines as shown in Table F.9-6. These constraints can be mitigated by switching 57 MW of generic battery resources to charging mode.

Table F.9-6: Kern-Tevis-Stockdale #1 and #2 115 kV line off-peak deliverability constraint

Overloaded Facility	Contingency	Area	Loading	
			BASE	SENS-01
Kern-Tevis-Stockdale #1 or #2 115 kV	Kern-Tevis-Stockdale #2 or #1 115 kV	South PG&E	138	220

Table F.9-7: Kern-Tevis-Stockdale #1 and #2 115kV line off-peak deliverability constraint summary

Affected renewable transmission zones			
		Base	Sensitivity
Renewable portfolio MW behind the constraint (installed capacity)		109	304
Energy storage (ES) portfolio MW behind the constraint (installed capacity)		95	135
Renewable curtailment without mitigation (MW) (installed capacity)		57	179
Mitigation Options:	Portfolio ES (in charging mode) (MW) <sup>[1]</sup>	57	Not feasible
	RAS	NA	NA
	Additional battery storage (MW)	NA	NA
	Transmission upgrades	NA	NA
Recommended Mitigation		Switch 57 MW of generic battery resources to charging mode	Reconductor

<sup>[1]</sup> The Portfolio energy storage (in charging mode) amount is the amount needed to mitigate the constraint after baseline battery storage is fully utilized.

### F.10 East of Pisgah area

The total capacity of resources, by resource type, selected with Full Capacity Deliverability Status (FCDS) as well as those selected as Energy Only (EO) in the East of Pisgah interconnection area are listed in Table F.10-1. The portfolios in the interconnection area are comprised of solar, wind (in-state and out-of-state), battery storage and geothermal resources. All portfolio resources are modeled in policy-driven assessments except in the on-peak deliverability assessment in which only FCDS resources are modeled.

Table F.10-1: East of Pisgah Interconnection Area – Base and Sensitivity Portfolios by Resource Types (FCDS, EO and Total)

Resource Type	Base Portfolio			Sensitivity Portfolio		
	FCDS	EO	Total	FCDS	EO	Total
Solar	770	1,946	2,716	1,320	4,196	5,516
Wind – In State	442	-	442	442	0	442
Wind – Out-of-State (Existing TX)	486	-	486	486	0	486
Wind – Out-of-State (New TX)	1,062	-	1,062	2,500	0	2,500
Wind – Offshore	-	-	-	0	0	0
Li Battery	1,236	-	1,236	2,711	0	2,711
Geothermal	440	-	440	727	0	727
Long Duration Energy Storage (LDES)	-	-	-	0	0	0
Biomass/Biogass	-	-	-	0	0	0
Distributed Solar	-	-	-	0	0	0
<b>Total</b>	<b>4,436</b>	<b>1,946</b>	<b>6,382</b>	<b>8,186</b>	<b>4,196</b>	<b>12,382</b>

Table F.10-2 shows adjustments to the base portfolio made by CPUC staff in the East of Pisgah Interconnection Area to account for allocated TPD and additional in-development resources identified.

Table F.10-2: East of Pisgah Interconnection Area – Adjustments to the base portfolio to account for adjustments to in-development resources and TPD allocations

	FCDS (MW)	EO (MW)	Total (MW)
Solar	88	47	135
Wind – In State	-	-	-
Wind – Out-of-State (Existing TX)	-	-	-
Wind – Out-of-State (New TX)	-	-	-
Wind - Offshore	-	-	-
Li Battery	778	-	778
Geothermal	-	-	-
Long Duration Energy Storage (LDES)	-	-	-
Biomass/Biogass	-	-	-
Distributed Solar	-	-	-
<b>Total</b>	<b>866</b>	<b>47</b>	<b>913</b>

The resources as identified in the CPUC busbar mapping for the East of Pisgah interconnection area are illustrated on the single-line diagram in Figure F.10-1.

Figure F.10-1: East of Pisgah Interconnection Area – Mapped<sup>19</sup> Base Portfolio

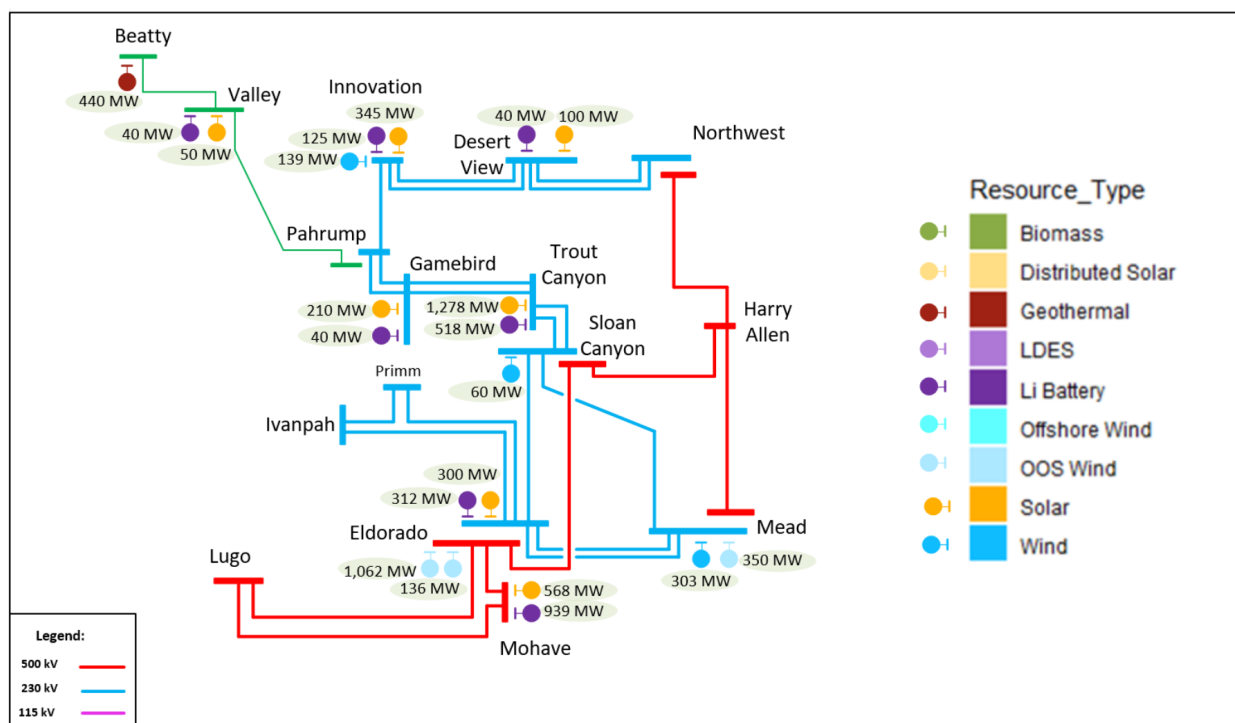

### F.10.1 VEA 138 kV Area

#### F.10.1.1 On-peak results

##### VEA 138 kV System Constraint

Geothermal and battery storage resources connecting to VEA’s 138kV buses are subject to curtailment in the base portfolio deliverability assessment due to normal loading limitations of 138 kV lines in the VEA area as well as multiple P1 and P7 contingency loading limitations as shown in Table F.10-3. The overloads exacerbate in the sensitivity portfolio deliverability assessment. As indicated in Table F.10-4, there are 360 MW portfolio resources undeliverable in base portfolio and 900 MW portfolio resources undeliverable in sensitivity portfolio. New 230 kV transmission facilities are necessary in the VEA area to make the portfolio resources deliverable and to provide more flexibility for future renewable and geothermal resources development in the area. RAS without transmission upgrades is not considered a potential mitigation because the overloads occur under normal condition.

<sup>19</sup> Mapped base portfolio includes the adjustments to the base portfolio made by CPUC staff in the East of Pisgah Interconnection Area to account for allocated TPD and additional in-development resources identified.

Table F.10-3: VEA 138 kV system on-peak deliverability constraints

Overloaded Facilities	Contingency	Loading (%)	
		Base Portfolio	Sensitivity Portfolio
Beatty – Lathrop SS 138kV Line	Base Case	342.93	513.95
Lathrop SS – Jackass Flats 138kV Line	Base Case	212.68	412.66
Lathrop SS – Valley SS 138kV Line	Base Case	209.71	367.37
Valley SS – Vista 138kV Line	Base Case	204.8	360.52
Jackass Flats – Mercury SS 138kV Line	Base Case	202.11	394.86
Vista – Pahrump 138kV Line	Base Case	192.31	404.07
Innovation 230/138kV Transformer	Base Case	176.75	280.78
Mercury SS –Innovation 138kV Line	Base Case	149.06	257.02
Pahrump – Gamebird 138kV Line	Base Case	<100	164.1
Jackass Flats – Mercury SS 138kV Line	Valley SS – Vista 138kV Line	374.59	745.68
	Pahrump - Vista 138kV Line	353.16	790.76
Lathrop SS – Jackass Flats 138kV Line	Valley SS – Vista 138kV Line	284.34	561.82
	Pahrump - Vista 138kV Line	268.37	595.42
	Trout Canyon-Sloan Canyon 230kV Nos 1 & 2	177.86	356.16
Mercury SS –Innovation 138kV Line	Valley SS – Vista 138kV Line	270.59	523.19
	Pahrump - Vista 138kV Line	254.33	557.39
	Trout Canyon-Sloan Canyon 230kV Nos 1 & 2	171.95	313.8
Innovation 230/138kV Transformer	Pahrump - Vista 138kV Line	223.86	487.34
	Valley SS – Vista 138kV Line	236.34	459.87
	Valley SS - Lathrop SS 138kV Line	222.43	462.04
IS Tap – Radar – Northwest 138kV Line	Pahrump - Vista 138kV Line	<100	165.87
	Innovation 230/138kV Transformer	178.69	278.44
Pahrump 230/138kV Transformer	Lathrop SS – Jackass Flats 138kV Line	<100	161.17
	Mercury SS –Innovation 138kV Line	<100	143.53
	Gamebird - Pahrump 138kV Line	<100	120.51
Pahrump – Gamebird 138kV Line	Lathrop SS – Jackass Flats 138kV Line	123.09	257.83
	Innovation-Mercury SW 138kV Line	114.56	235.8
	Jackass Flats – Mercury SS 138kV Line	<100	172.79
	Innovation 230/138kV Transformer	<100	169.53
Vista – Pahrump 138kV Line	Lathrop SS – Jackass Flats 138kV Line	268.37	595.42
	Mercury SS –Innovation 138kV Line	249.8	547.47
	Jackass Flats – Mercury SS 138kV Line	211.95	410.32
	Innovation 230/138kV Transformer	214.47	407.39
	Desert View-Northwest 230kV Nos 1 & 2	151.56	318.29
	Innovation-Desert View 230kV Nos 1 & 2	150.72	314.93
Valley SS – Vista 138kV Line	Lathrop SS – Jackass Flats 138kV Line	284.34	561.82
	Mercury SS –Innovation 138kV Line	265.77	513.87
	Jackass Flats – Mercury SS 138kV Line	220.12	377.82
	Innovation 230/138kV Transformer	222.68	374.74
	Desert View-Northwest 230kV Nos 1 & 2	160.78	286.35
	Innovation-Desert View 230kV Nos 1 & 2	159.93	282.99



Table F.10-4: VEA 138 kV System constraint summary

Affected transmission zones/substations	VEA 138 kV substations	
	Base Portfolio	Sensitivity Portfolio
Generic portfolio MW behind the constraint (installed FCDS capacity)	480	1,330
Generic battery storage portfolio MW behind the constraint (installed FCDS capacity)	40	590
Deliverable generic portfolio MW w/o mitigation (Installed FCDS capacity)	120	430
Total undeliverable baseline and portfolio MW (Installed FCDS capacity)	360	900
Mitigation Options	RAS	Not applicable
	Re-locate generic portfolio battery storage (MW)	Not applicable
	Potential transmission upgrade	Beatty 230 kV Project
Recommended Mitigation	Beatty 230 kV Project	

### Beatty 230 kV Project

The recommended Beatty 230 kV Project scope includes:

- Build a new Johnnie Corner 230 kV station and loop into Pahrump – Innovation 230 kV line.
- Expand existing Beatty, Lathrop, Valley Switch and Vista 138 kV substations to 230 kV substations.
- Build 32 miles Beatty – Lathrop 230 kV line next to the existing 138kV line in an adjacent ROW.
- Build 30 miles Johnnie – Valley Switch – Lathrop 230 kV DCTL lines next to the existing 138kV line in an adjacent ROW.
- Install a second Johnnie – Innovation and Johnnie – Vista – Pahrump 230 kV line on the Innovation – Pahrump double circuit tower approved in 2021/22 TPP.

With the Beatty 230 kV Project modeled, all the portfolio resources at Beatty, Valley, Lathrop and Vista 138 kV will be relocated to the new 230 kV buses in base portfolio and sensitivity portfolio analysis. The upgrade is found to be sufficient to mitigate all the VEA 138 kV system constraints identified in Table F.10-3 above in both base portfolio and sensitivity portfolio analysis. The cost estimate of the Beatty 230 kV Project is \$155 million in 2022 dollars. An additional benefit of the Beatty 230 kV project is that the Beatty 138 kV system is considered to

be aging infrastructure nearing the end of life, and at the end of life for the 138 kV facilities they can be retired and the load can be served from the parallel 230 kV system.

### F.10.1.2 Off-peak results

#### VEA 138 kV System Constraint

Similar to the constraint identified in the on peak deliverability study, solar and geothermal resources connecting to VEA's 138 kV buses are subject to curtailment in the base portfolio and sensitivity portfolio off-peak deliverability assessment due to normal and contingency loading limitations of multiple 138 kV lines in the VEA area as shown in Table F.10-5.

The portfolio battery storage is not sufficient to mitigate all the overloads. Adding more battery storage is not a viable mitigation due to on-peak deliverability limitations. RAS without transmission upgrades is also not considered a potential mitigation because the overloads occur under base case conditions. The Beatty 230 kV Upgrade project described in the on peak deliverability results will help mitigation the off-peak deliverability constraint and is the recommended off-peak deliverability constraint mitigation.

Table F.10-5: VEA 138 kV system off-peak deliverability constraints

Overloaded Facilities	Contingency	Loading (%)	
		Base Portfolio	Sensitivity Portfolio
Lathrop SS – Jackass Flats 138kV line	Base Case	<100	422.06
	Pahrump – Vista 138kV line	118.42	606.71
Lathrop SS – Valley SS 138kV Line	Base Case	<100	231.78
Valley SS – Vista 138kV Line	Base Case	<100	333.17
	Lathrop SS – Jackass Flats 138kV line	116.77	506.43
Jackass Flats – Mercury SS 138kV Line	Base Case	<100	406.63
	Pahrump – Vista 138kV line	149	808.29
Vista – Pahrump 138kV Line	Base Case	<100	468.14
	Lathrop SS – Jackass Flats 138kV line	119.19	606.71
Innovation 230/138kV Transformer	Base Case	<100	333.66
	Pahrump – Vista 138kV line	<100	469.36
	Valley SS – Vista 138kV line	<100	389.59
Mercury SS –Innovation 138kV Line	Base Case	<100	307.33
	Pahrump – Vista 138kV line	101.69	551.64
Beatty – Lathrop SS 138kV Line	Base Case	<100	289.54
Pahrump – Gamebird 138kV Line	Base Case	<100	241.44
Pahrump 230/138kV Transformers	Base Case	<100	122.2
Gamebird 230/138kV Transformer	Base Case	<100	109.8
	Pahrump 230/138kV transformer No.1 or 2	<100	114.96
IS Tap – Radar – Northwest 138kV Line	Innovation 230/138kV transformer	<100	236.85
	Pahrump - Vista 138kV line	<100	181.8

Table F.10-6: VEA 138 kV system constraints summary

Affected transmission zones		VEA 138kV substations	
		Base Portfolio	Sensitivity Portfolio
Generic portfolio MW behind the constraint (Installed capacity)		490	1,590
Energy storage portfolio MW behind the constraint (Installed capacity)		40	590
Renewable curtailment MW without mitigation (Installed capacity)		440	1,390
Mitigation Options:	Portfolio ES (in charging mode) (MW)	Not sufficient	
	RAS	Not applicable	
	Additional battery storage (MW)	Not applicable	
	Transmission upgrades	Beatty 230 kV project	
Recommended Mitigation		Beatty 230 kV project	

**F.10.2 GLW 230 kV Area**

**F.10.2.1 On-peak results**

**GLW 230 kV System Constraint**

Solar, geothermal and battery resources connecting to VEA 138 kV buses and GLW’s Trout Canyon, Gamebird, Innovation and Desert View 230 kV buses are identified to be behind the GLW 230 kV system constraint. Table F.10-7 summarizes all the transmission facilities overloads in GLW 230 kV system constraint.

Table F.10-7: GLW 230 kV system on-peak deliverability constraints

Overloaded Facilities	Contingency	Loading (%)	
		Base Portfolio	Sensitivity Portfolio
IS Tap – Radar – Northwest 138kV line	Desert View-Northwest 230kV Nos 1 & 2	120.23	224.71
	Innovation-Desert View 230kV Nos 1 & 2	111.18	189.71
Amargosa 230/138kV Transformer, Sandy-Amargosa and Gamebird-Sandy 138kV lines	Trout Canyon-Sloan Canyon 230kV No.2	<100	108.62
	Desert View-Northwest 230kV Nos 1 & 2	<100	150.81
	Innovation-Desert View 230kV Nos 1 & 2	<100	140.07

	Trout Canyon-Sloan Canyon 230kV Nos 1 & 2	<100	198.54
Innovation PST	Desert View-Northwest 230kV Nos 1 & 2	<100	124.86
	Innovation-Desert View 230kV Nos 1 & 2	<100	106.13
Innovation – Desert View 230kV No.1 line	Basecase	<100	118.57
	Trout Canyon-Sloan Canyon 230kV Nos 1 & 2	<100	172.4
	Innovation-Desert View 230kV No.2	<100	149.27
	Trout Canyon-Sloan Canyon 230kV No.1 or No.2	<100	105.64
Innovation – Desert View 230kV No.2 line	Trout Canyon-Sloan Canyon 230kV Nos 1 & 2	<100	120.91
Pahrump - Gamebird 138kV	Desert View-Northwest 230kV Nos 1 & 2	<100	164.77
	Innovation-Desert View 230kV Nos 1 & 2	<100	157.86

Table F.10-8: GLW 230 kV system constraint summary

Affected transmission zones/substations		VEA 138 kV and GLW 230 kV substations	
		Base Portfolio	Sensitivity Portfolio
Generic portfolio MW behind the constraint (installed FCDS capacity)		2,253	4,102
Generic battery storage portfolio MW behind the constraint (installed FCDS capacity)		635	2,022
Deliverable generic portfolio MW w/o mitigation (Installed FCDS capacity)		2,034	2,456
Total undeliverable baseline and portfolio (Installed FCDS capacity)		219	1,646
Mitigation Options	RAS	Innovation RAS	Not applicable
	Re-locate portfolio battery storage (MW)	Reduce 165 MW battery storage portfolio at Innovation and Desert View	Not sufficient
	Potential transmission upgrade	Not required	1. Trout Canyon – Lugo 500 kV line 2. Trout Canyon – Sloan Canyon 500 kV upgrade
Recommended Mitigation		Innovation RAS	Trout Canyon – Sloan Canyon 500 kV upgrade

With 2,253 MW base portfolio resources modeled, the deliverability assessment only identified the IS Tap-Northwest 138 kV tie line overload following two category P7 contingencies. The overloads could be mitigated by modifying the Innovation RAS to include the two category P7 contingencies. Alternatively the overloads could be mitigated by relocating the 165 MW portfolio battery storage at Innovation and Desert View to other substations.

With over 4,000 MW sensitivity portfolio resources modeled, the deliverability assessment identified various 230 kV and 138 kV overloads under base case, Category P1 and P7 contingency conditions as shown in the Table F.10-7. The constraints are mainly on the Innovation – IS Tap – Northwest 138 kV lines, Pahrump – Gamebird – Sandy – Amargosa 138kV lines and Innovation – Desert View 230 kV lines. RAS without transmission upgrades is not considered a potential mitigation because the overloads occur under normal condition. Relocating battery storage by itself is not sufficient to mitigate all the overloads. Besides, as discussed in off-peak deliverability results, this area will rely on battery charging to mitigate off-peak deliverability constraints. Taking these into account, relocating battery storage is not considered a potential mitigation.

The sensitivity portfolio maps 1,230 MW FCDS resources (827 MW battery storage and 403 MW solar) at Trout Canyon 230 kV bus which is about 1/3 of the total portfolio resources in VEA and GLW system. In addition, there is 128 MW battery storage and 122 MW solar FCDS baseline resources at Trout Canyon. Adding these up, there is a total of 1,480 MW FCDS resources at Trout Canyon 230 kV bus. In comparison, there is 303 MW FCDS wind resource at Sloan Canyon 230 kV bus and 560 MW FCDS resources (310 MW battery storage and 250 MW solar) at Gamebird 230 kV bus. Using the HSN deliverability study assumptions for resource production there is 2,869 MW of resources that would need to flow on ISO facilities between Trout Canyon and Sloan Canyon which exceeds the 2,308 MW of the facility ratings on that path. Therefore this power could not flow without relying on the transmission capability of neighboring system facilities. In addition, there is approximately 5,000 MW of solar and geothermal (FCDS + EODS) resources that would need to flow between Trout Canyon and Sloan Canyon, and approximately 2,000 MW of storage resources. This leaves about 3,000 MW of solar and geothermal resources that would need to flow, but is limited by 2,308 MW on that path.

When evaluating the Trout Canyon – Lugo 500 kV line option, as discussed in Section F10.3.1, two studies were performed with Trout Canyon – Sloan Canyon 230 kV DCTL rebuilt to 500 kV compared to remaining at 230 kV. Table F.10-9 summarizes the sensitivity portfolio results with the project modeled.

Table F.10-9: Sensitivity portfolio deliverability result with Trout Canyon – Lugo 500 kV project

Overloaded Facilities	Contingency	Loading %	
		Trout-Sloan 230	Trout-Sloan 500
Innovation-Desert View 230kV No.1 line	Gamebird-Trout Canyon 230kV Nos.1&2	120.43	120.64
	Trout Canyon-Lugo 500kV line	110.55	<50
Pahrump 230/138kV transformer No.1 or 2 Pahrump-Gamebird 138kV line	Pahrump-Gamebird 230kV Nos.1&2	128.83	121.67
		137.69	125.5

Rebuilding Trout Canyon – Sloan Canyon DCTL lines to 500 kV would help alleviate contingency loading on Pahrump transformers and Pahrump – Gamebird 138 kV line and reduce generation curtailment by 150 MW. There is one Category P1 contingency overload on Innovation – Desert View 230 kV No.1 line with Trout Canyon – Sloan Canyon 230 kV DCTL option. Rebuilding Trout Canyon – Sloan Canyon DCTL lines to 500 kV would eliminate this Category P1 overload. Table F.10-10 summarizes the sensitivity portfolio results with the Trout Canyon – Sloan Canyon 500 kV upgrade modeled.

Table F.10-10: Sensitivity portfolio deliverability result with Trout Canyon – Sloan Canyon 500 kV upgrade

Overloaded Facilities	Contingency	Loading %
Amargosa 230/138kV transformer	Trout Canyon-Sloan Canyon 500kV Nos.1&2	166.09
Sandy-Amargosa 138kV line		153.32
Gamebird-Sandy 138kV line		132.4
Gamebird 230/138kV transformer		112.53
IS Tap-Northwest 138kV line	Trout Canyon-Sloan Canyon 500kV Nos.1&2	140.4
	Desert View-Northwest 230kV Nos.1&2	101.37
Pahrump 230/138kV transformer	Pahrump-Gamebird 230kV Nos.1&2	99.2
Pahrump-Gamebird 138kV line	Pahrump-Gamebird 230kV Nos.1&2	88.79

The Trout Canyon – Sloan Canyon 500 kV upgrade project is able to mitigate and alleviate most of the overloads identified in Table F.10-7. There are two Category P7 contingencies that would overload the Gamebird – Sandy – Amargosa 138 kV path and the IS Tap – Northwest 138 kV line. These overloads could be mitigated by RAS scheme and the total nameplate capacity of generation that will be tripped by RAS is less than 900 MW. The Trout Canyon-Sloan Canyon 500 kV upgrade would avoid the need to utilize neighboring system transmission capability described above.

Expanding Trout Canyon substation to 500 kV is recommended to accommodate the portfolio resources at Trout Canyon and enhance GLW 230 kV transmission system export capability.

#### GLW/VEA Area Upgrade – Revised Scope

To mitigate the GLW 230 kV System constraint the ISO is recommending to rescope the previously approved GLW/VEA Area Upgrades project that was approved in the 2021-2022 Transmission Plan. The scope of the previously approved project is as follows.

- Rebuild Northwest – Desert View, Pahrump – Gamebird, Gamebird – Trout Canyon and Trout Canyon – Sloan Canyon 230 kV to double circuit lines;
- Install a second Innovation – Desert View 230 kV line;
- Rebuild Innovation – Pahrump 230 kV line;
- Add a 500/230 kV transformer at Sloan Canyon and loop in the Harry Allen – Eldorado 500 kV line;
- Install a 138 kV phase shifter at Innovation on the planned tie-line to NVE; and

- Upgrade VEA’s 230/138 kV Amargosa transformer

The recommended revised scope of the GLW/VEA Area Upgrades project scope is as follows.

- Install a new Trout Canyon 500 kV bus and three 500/230 kV transformers at Trout Canyon;
- Rebuild Trout Canyon – Sloan Canyon 230 kV DCTL lines to 500kV DCTL lines;
- Rebuild Northwest – Desert View, Pahrump – Gamebird and Gamebird – Trout Canyon 230 kV to double circuit lines;
- Rebuild Innovation – Desert View 230 kV No.1 line with a normal rating of 1,154 MVA and an emergency rating of 1,578 MVA;
- Install a second Innovation – Desert View 230 kV line;
- Rebuild Innovation – Pahrump 230 kV line;
- Add a 500/230 kV transformer at Sloan Canyon and loop in the Harry Allen – Eldorado 500 kV line;
- Install a 138 kV phase shifter at Innovation on the planned tie-line to NVE; and
- Upgrade VEA’s 230/138 kV Amargosa transformer.

Figure F.10-2: GLW/VEA Transmission System with Recommended Re-scoping of the GLW/VEA Area Upgrades Project and the Beatty 230 kV Project

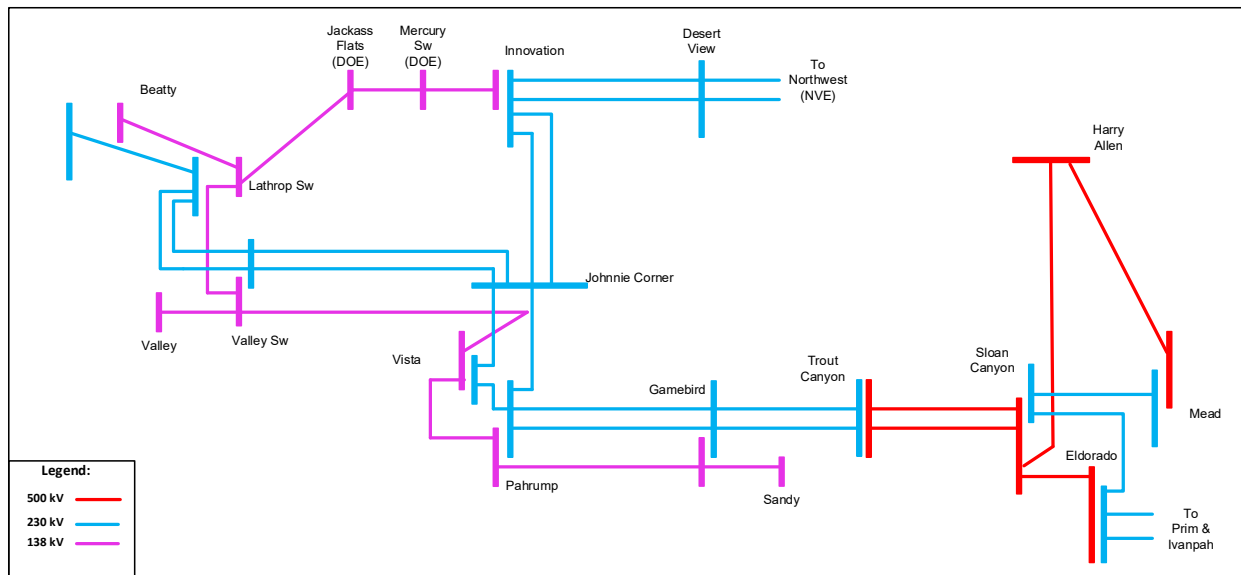

The estimated cost of the GLW/VEA Area Upgrades project as approved in the 2021-2022 Transmission Plan was \$278 million. The estimated cost of the increased scope is \$228 million for a total cost of the recommended re-scoped project of \$506 million. The in-service date for the re-scoped GLW/VEA Area Upgrades project is 2027.

**F.10.2.2 Off-peak results****GLW 230 kV System Constraint**

Solar and geothermal resources connecting to VEA 138 kV buses and GLW's Trout Canyon, Gamebird, Innovation and Desert View 230 kV buses are identified to contribute to the GLW 230 kV system constraint. The constraint is identified in the on-peak deliverability assessment as well. However, the overloads are more severe in the off-peak deliverability assessment results. Table F.10-11 summarizes all the transmission facilities overloads in GLW 230kV system constraint.

Table F.10-11: GLW 230kV system off-peak deliverability constraints

Overloaded Facilities	Contingency	Loading (%)	
		Base Portfolio	Sensitivity Portfolio
Innovation – Desert View 230kV No.1 line	Base Case	<100	174.58
Innovation – Desert View 230kV No.2 line	Base Case	<100	117.2
IS Tap – Radar – Northwest 138kV Line	Innovation – Desert View 230kV No.2	<100	133.58
	Desert View-Northwest 230kV Nos 1 & 2	151.87	293.63
	Trout Canyon-Sloan Canyon 230kV Nos 1 & 2	<100	162.91
Amargosa 230/138kV Transformer, Sandy-Amargosa and Gamebird-Sandy 138kV lines	Base Case	<100	156.65
	Desert View-Northwest 230kV Nos 1 & 2	122.29	240.48
	Trout Canyon-Sloan Canyon 230kV Nos 1 & 2	168.43	341.24
Gamebird 230/138kV transformer	Pahrump – Gamebird 230kV Nos. 1&2	<100	150.61
Innovation PST	Desert View-Northwest 230kV Nos 1 & 2	<100	161.99
Innovation – Desert View 230kV No.1 line	Trout Canyon-Sloan Canyon 230kV Nos 1 & 2	126.25	236.71
	Innovation-Desert View 230kV No.2 line	107.89	229.32
	Trout Canyon-Sloan Canyon 230kV No.1 or No.2 line	<100	136.73
Innovation – Desert View 230kV No.2 line	Trout Canyon-Sloan Canyon 230kV Nos 1 & 2	<100	169.02
	Innovation-Desert View 230kV No.1	<100	133.48
Jackass Flats – Mercury SS 138kV Line	Trout Canyon-Sloan Canyon 230kV Nos 1 & 2	133.49	482.66
Lathrop SS – Jackass Flats 138kV Line	Trout Canyon-Sloan Canyon 230kV Nos 1 & 2	106.8	364.04
Pahrump – Innovation 230kV Line	Trout Canyon-Sloan Canyon 230kV Nos 1 & 2	<100	123.84

There is one Category P1 and a few Category P7 contingency overloads identified in base portfolio analysis. The Innovation – Desert View 230 kV No.1 overload following loss of Innovation – Desert View 230 kV No.2 line could be mitigated by the Innovation RAS to trip 345 MW installed capacity generation at Innovation or by charging 125 MW battery storage at Innovation. The worst Category P7 contingency is loss of Trout Canyon – Sloan Canyon 230 kV Nos.1&2 lines. The overloads could be mitigated by the Sloan Canyon RAS to trip 1,018 MW installed capacity generation at Trout Canyon. Alternatively, the overloads could be mitigated by



charging 555 MW portfolio battery storage in addition to charging 127.8 MW baseline battery storage.

Multiple base case, Category P1 and P7 contingency overloads are identified in sensitivity portfolio analysis. The Trout Canyon – Lugo 500 kV project and the Trout Canyon – Sloan Canyon 500 kV upgrade project discussed in on-peak deliverability assessment would help address off-peak deliverability constraint as well. Besides transmission upgrade, the Innovation – Desert View 230 kV lines base case overloads could be mitigated by charging up to 1,542 MW portfolio battery storage. Charging portfolio and baseline battery storage would also mitigate majority of Category P1 and P7 contingency overloads. However, for the IS Tap – Radar – Northwest 138 kV line overload following Category P7 contingency of Desert View – Northwest 230 kV Nos.1&2 lines, charging the total 2,150 MW portfolio and baseline battery storage would not be sufficient. Adding more battery storage is not viable due to on-peak deliverability constraint. In this case, the overload might be mitigated by both charging the battery storage and utilizing RAS to curtail generation. However, the feasibility of the RAS would need to be verified.

Table F.10-12: GLW 230 kV system constraints summary

Affected transmission zones		VEA 138 kV and GLW 230 kV substations	
		Base Portfolio	Sensitivity Portfolio
Generic portfolio MW behind the constraint (Installed capacity)		2,605	4,967
Energy storage portfolio MW behind the constraint (Installed capacity)		635	2,022
Renewable curtailment MW without mitigation (Install capacity)		1,018	2,473
Mitigation Options:	Portfolio ES (in charging mode) (MW)	635	Not sufficient
	RAS	Innovation RAS and Sloan Canyon RAS	Not applicable
	Additional battery storage (MW)	Not required	Not applicable
	Transmission upgrades	Not required	1. Trout Canyon – Lugo 500 kV project 2. Trout Canyon – Sloan Canyon 500 kV upgrade
Recommended Mitigation		Innovation RAS and Sloan Canyon RAS	Trout Canyon – Sloan Canyon 500 kV upgrade recommended for on-peak mitigation

**Sloan Canyon – Mead 230 kV Constraint**

Solar, wind and geothermal resources connecting VEA 138 kV buses, GLW 230 kV buses and Eldorado 230 kV bus in the sensitivity portfolio are subject to curtailment in the off-peak deliverability analysis due to the Sloan Canyon – Mead 230 kV constraint as shown in Table F.10-13. The Sloan Canyon – Mead 230 kV line is found to be overloaded under base case and multiple category P1 contingency conditions. Eldorado 500/230 kV 5AA transformer is also marginally overloaded following loss of Sloan Canyon – Mead 230 kV line. All of these overloads are identified under sensitivity portfolio off-peak deliverability assessment only.

Table F.10-13: Sloan Canyon – Mead 230 kV off-peak deliverability constraints

Overloaded Facilities	Contingency	Loading (%)	
		Base Portfolio	Sensitivity Portfolio
Sloan Canyon – Mead 230kV line	Base case	<100	122.66
	Sloan Canyon 500/230kV transformer	<100	131.98
	Eldorado 500/230kV 5AA transformer	<100	136.4
	Sloan Canyon – Eldorado 500kV line	<100	117.87
	Eldorado – McCullough 500kV line	<100	112.53
Eldorado 500/230kV 5AA transformer	Sloan Canyon – Mead 230kV line	<100	100.91

The above overloads could be mitigated by charging about 1,158MW portfolio energy storage that is behind the constraint.

Table F.10-14: Sloan Canyon – Mead 230 kV Constraint Summary

Affected transmission zones		Southern_Nevada_Geothermal, Southern_Nevada_Wind, Southern_NV_Eldorado_Solar, Southern_NV_Eldorado_Li_Battery,	
		<b>Base Portfolio</b>	<b>Sensitivity Portfolio</b>
Generic portfolio MW behind the constraint (Installed capacity)		2,805	4,971
Energy storage portfolio MW behind the constraint (Installed capacity)		903	1,873
Renewable curtailment without mitigation (MW) (Installed capacity)		0	1,823
Mitigation Options:	Portfolio ES (in charging mode) (MW)	Not required	1,158
	RAS	Not required	Not applicable
	Additional battery storage (MW)	Not required	Not required
	Transmission upgrades	Not required	Not required
Recommended Mitigation		Not required	Energy storage charging

### F.10.3 SCE East of Pisgah Area

#### F.10.3.1 On-peak results

##### Lugo – Victorville 500 kV Area Constraint

Lugo – Victorville 500 kV area constraint includes multiple 500 kV lines: Lugo – Victorville 500 kV, Eldorado – Lugo 500 kV, Eldorado – McCullough 500 kV and Victorville – McCullough 500 kV lines. Multiple base case and/or contingency overloads have been identified in base portfolio or sensitivity portfolio analysis as listed in Table F.10-15.

Table F.10-15: Lugo – Victorville 500kV area on-peak deliverability constraints

Overloaded Facilities	Contingency	Loading (%)	
		Base Portfolio	Sensitivity Portfolio
Victorville – McCullough 500kV Line	Base Case	<100	112.11
Victorville – McCullough 500kV Line	Eldorado-Lugo 500kV Line	<100	112.81
Lugo – Victorville 500kV Line	Base Case	<100	106.4
Lugo-Victorville 500kV Line	Eldorado-Lugo 500kV Line	103.5	125.6
Lugo-Victorville 500kV Line	Lugo-Mohave 500kV Line	<100	107.39
Lugo-Victorville 500kV Line	Eldorado-Mohave 500kV Line	<100	104.94
Eldorado – McCullough 500kV Line	Eldorado-Lugo 500kV Line	<100	118.57
Eldorado – Lugo 500kV Line	Lugo-Victorville 500kV Line	<100	113.03

A minor contingency overload on Lugo – Victorville 500 kV line following loss of Eldorado – Lugo 500 kV line was observed in the base portfolio analysis. The overload could be mitigated by extending the existing Lugo – Victorville N-1 RAS.

A severe contingency overload and an overload with all facilities in-service was identified on the Lugo-Victorville 500 kV line in the sensitivity portfolio analysis. A new Trout Canyon – Lugo 500 kV line discussed in Section F.10.2 was also found to be able to mitigate all the identified Lugo – Victorville 500 kV area constraints in the sensitivity portfolio analysis. Table F.10-16 summarizes the sensitivity portfolio result with this project modeled.

Table F.10-16: Sensitivity portfolio deliverability result with Trout Canyon – Lugo 500 kV project

Overloaded Facilities	Contingency	Loading %
Victorville-McCullough 500 kV	Base Case	93.11
	Eldorado-Lugo 500 kV line	87.19
Lugo-Victorville 500 kV	Base Case	<50
	Eldorado-Lugo 500 kV line	90.26
	Trout Canyon-Lugo 500 kV line	89.75

Another option is to build a new Eldorado – Lugo 500 kV No.2 line which could also mitigate all the identified Lugo – Victorville 500 kV area constraints in the sensitivity portfolio analysis. Table F.10-17 summarizes the sensitivity portfolio results with this project modeled.

Table F.10-17: Sensitivity portfolio deliverability result with Eldorado – Lugo 500 kV No.2 line

Overloaded Facilities	Contingency	Loading %
Victorville-McCullough 500 kV	Base Case	93.89
	Eldorado-Lugo 500 kV	87.47
Lugo-Victorville 500 kV	Base Case	<50
	Eldorado-Lugo 500 kV	90.07

Table F.10-18 below provides a summary of Lugo – Victorville 500 kV area on-peak deliverability constraint.

Table F.10-18: Lugo – Victorville 500 kV area constraint summary

Affected transmission zones/substations		Southern_Nevada_Geothermal, Southern_Nevada_Wind, Southern_NV_Eldorado_Solar, Southern_NV_Eldorado_Li_Battery, Northern_Nevada_Geothermal, Wyoming_Wind, Idaho_Wind, New_Mexico_Wind, SW_Ext_Tx_Wind, Hassayampa, Hoodoo Wash, Imperial Valley, ECO, Goleta, Moorpark, Santa Clara, Springville, Vestal, Big Creek, Pastoria, Delany, Red Bluff and Colorado River substations	
		<b>Base Portfolio</b>	<b>Sensitivity Portfolio</b>
Generic portfolio MW behind the constraint (installed FCDS capacity)		6,895	16,374
Generic battery storage portfolio MW behind the constraint (installed FCDS capacity)		2,467	6,789
Deliverable generic portfolio MW w/o mitigation (Installed FCDS capacity)		6,500	11,380
Total undeliverable baseline and portfolio MW (Installed FCDS capacity)		395	4,994
Mitigation Options	RAS	Expanding the Lugo – Victorville RAS	Not applicable
	Re-locate portfolio battery storage (MW)	Not required	Not applicable
	Potential transmission upgrade	Not required	1. Trout Canyon – Lugo 500 kV line 2. Eldorado – Lugo 500 kV No.2 line
Recommended Mitigation		Expanding the Lugo – Victorville RAS	Trout Canyon – Lugo 500 KV line project

The Lugo – Victorville 500 kV area constraint was identified requiring mitigation in the base portfolio as well as in the sensitivity portfolio. The ISO was intending on recommending approval of the Trout Canyon – Lugo 500 kV Line based upon the alternative analysis to mitigate the constraint.

Figure F.10-3: Trout Canyon – Lugo 500 kV Line One-line Diagram

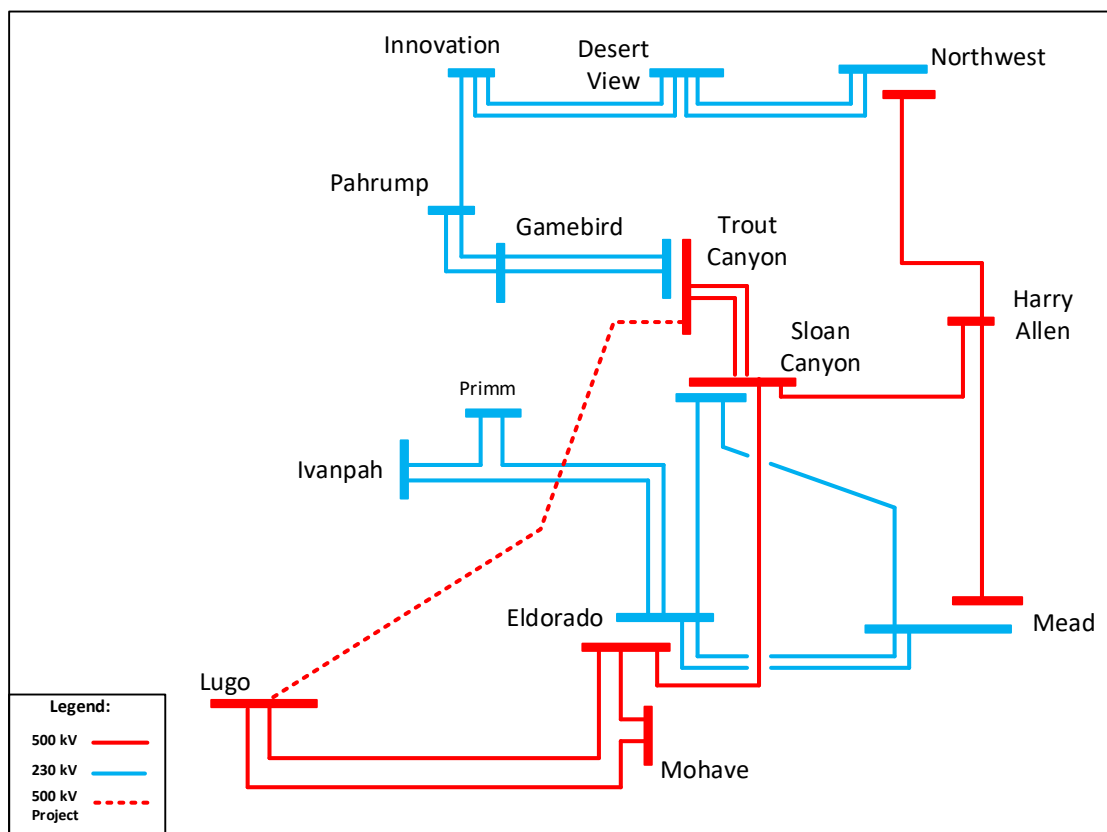

The ISO considered the alternatives of either a Trout Canyon – Lugo 500 kV line and Eldorado – Lugo 500 kV No. 2 line that would mitigate the identified Lugo – Victorville 500 kV area constraints in the sensitivity portfolio analysis. The cost estimate of the Trout Canyon – Lugo 500 kV line project is approximately \$1.5 to 2 billion while the cost estimate of the Eldorado – Lugo 500 kV No.2 line project is approximately \$2.1 billion. With Eldorado – Lugo 500 kV No. 2 line option, there is a need to build a second Sloan Canyon – Eldorado 500 kV line which has a cost estimate of \$14 million, and includes an increase in line crossings in a very congested area. Besides mitigating the Lugo – Victorville 500 kV area constraints, the Trout Canyon – Lugo 500 kV line would improve the deliverability of GLW and VEA area resources and mitigate GLW 230 kV area constraints as indicated in section F.10.2.1. It would also provide opportunity for future transmission expansion in the area and to build transmission access to the geothermal resources in Nevada.

The ISO received a letter from Lotus Infrastructure Partners on April 25, 2023<sup>20</sup> identifying an alternative that the ISO will need to take additional time to assess. The assessment will need to determine how much capacity of the estimated 2,200 MW capacity increase identified would be available to the CAISO and the technical performance of the alternative to meet the needs to address the identified constraint. The ISO will undertake the assessment and will bring forward a recommended mitigation plan for the Lugo – Victorville 500 kV area constraint as either an extension of the 2022-2023 transmission planning process or in the next planning cycle.

### F.10.3.2 Off-peak results

#### Eldorado – McCullough 500 kV Constraint

Eldorado – McCullough 500 kV line is identified to be overloaded following Category P1 contingencies of Eldorado –Lugo 500 kV line and Lugo – Mohave 500 kV line in sensitivity portfolio off-peak deliverability assessment. The overload is also identified in on-peak deliverability assessment as part of the Lugo – Victorville 500 kV constraint. But the overload is higher in the off-peak deliverability assessment. Solar, wind and geothermal resources in Nevada, Wyoming and Idaho are behind the constraint and are subject to curtailment. Table F.10-19 summarizes all the transmission facilities overloads in Eldorado – McCullough 500kV constraint.

Table F.10-19: Eldorado – McCullough 500 kV off-peak deliverability constraints

Overloaded Facilities	Contingency	Loading (%)	
		Base Portfolio	Sensitivity Portfolio
Eldorado – McCullough 500 kV Line	Eldorado-Lugo 500 kV Line	<100	124.54
Eldorado – McCullough 500 kV Line	Lugo-Mohave 500 kV Line	<100	103.9

The overloads could be mitigated by charging about 2,171MW battery storage in the portfolio. Alternatively, the transmission upgrade being evaluated to mitigate the Lugo – Victorville 500 kV on-peak deliverability constraint could also mitigate the Eldorado – McCullough 500 kV off-peak constraint.

<sup>20</sup> <http://www.caiso.com/InitiativeDocuments/Letter-Alternative-to-Trout-Canyon-Lugo-500-kV-line-Apr242023.pdf>

Table F.10-20: Eldorado – McCullough 500 kV constraint summary

Affected transmission zones		Southern_Nevada_Geothermal, Southern_Nevada_Wind, Southern_NV_Eldorado_Solar, Southern_NV_Eldorado_Li_Battery, Northern_Nevada_Geothermal, Wyoming_Wind Idaho_Wind	
		<b>Base Portfolio</b>	<b>Sensitivity Portfolio</b>
Generic portfolio MW behind the constraint (Installed capacity)		6,896	8,757
Energy storage portfolio MW behind the constraint (Installed capacity)		2,467	2,605
Renewable curtailment without mitigation (MW) (Installed capacity)		0	1,803
Mitigation Options:	Portfolio ES (in charging mode) (MW)	Not required	2,171
	RAS	Not required	Not sufficient
	Additional battery storage (MW)	Not required	Not applicable
	Transmission upgrades	Not required	1. Trout Canyon – Lugo 500 kV line 2. Eldorado – Lugo 500 kV No.2 line
Recommended Mitigation		Not required	Trout Canyon – Lugo 500 kV line recommended for on-peak mitigation

### F.10.4 Conclusion and recommendation

Heavy base case and contingency overloads are identified in the VEA 138 kV system in base portfolio and sensitivity portfolio, on-peak and off-peak deliverability analysis. The Beatty 230 kV upgrade project is required in all different scenarios to deliver geothermal, solar and battery storage portfolio resources in the VEA area. The cost estimate of the project is \$155 million with an in-service date of 2027. CAISO recommends the project for approval as a policy driven project in the 2022-2023 transmission planning process.

Minor contingency overloads are identified in the GLW 230 kV system and Lugo – Victorville 500 kV system in the base portfolio on-peak deliverability analysis. The overloads could be mitigated by the existing Innovation RAS and extending the existing Lugo – Victorville RAS. A few contingency overloads are identified in the GLW 230 kV system in the base portfolio off-peak deliverability analysis. Charging portfolio battery storage or relying on existing Innovation and Sloan Canyon RAS are adequate to mitigate the overloads.

Numerous base case and contingency overloads are identified in the GLW 230 kV system in the sensitivity portfolio on-peak and off-peak deliverability analysis. Among the 4,352 MW sensitivity portfolio, 1,480 MW is mapped at Trout Canyon 230 kV substation which is almost 1/3 of the total portfolio in VEA and GLW system. Trout Canyon 500 kV substation is recommended to accommodate the sensitivity portfolio resources.

In 2021-2022 Transmission Plan, the ISO approved the GLW/VEA Upgrades Project. With the identified need for a Trout Canyon 500 kV substation, the ISO recommended revising the project scope of the previously approved GLW/VEA Upgrades project as follows to mitigate the GLW 230 kV area constraints:

- Install a new Trout Canyon 500 kV bus and three 500/230 kV transformers at Trout Canyon;
- Rebuild Trout Canyon – Sloan Canyon 230 kV DCTL lines to 500kV DCTL lines;
- Rebuild Northwest – Desert View, Pahrump – Gamebird and Gamebird – Trout Canyon 230 kV to double circuit lines;
- Rebuild Innovation – Desert View 230 kV No.1 line with a normal rating of 1,154 MVA and an emergency rating of 1,578 MVA;
- Install a second Innovation – Desert View 230 kV line;
- Rebuild Innovation – Pahrump 230 kV line;
- Add a 500/230 kV transformer at Sloan Canyon and loop in the Harry Allen – Eldorado 500 kV line;
- Install a 138 kV phase shifter at Innovation on the planned tie-line to NVE; and
- Upgrade VEA's 230/138 kV Amargosa transformer.

The estimated cost of the GLW/VEA Area Upgrades project as approved in 2021-2022 Transmission Plan was \$278 million. The estimated cost of the increased scope is \$228 million. The total cost of the re-scoped project is \$506 million. The in-service date of the project is 2027.

To mitigate the identified Lugo – Victorville 500 kV constraints and retire the existing Lugo – Victorville N-1 RAS, the ISO recommend building a new Trout Canyon – Lugo 500 kV line, approximately 180 miles, with series compensation. The project would also improve GLW and VEA area generation deliverability and allow future transmission expansion to get access to the geothermal resources in Nevada. The estimated cost of the project is \$1,500 to 2,000 million with an in-service date of 2033.



## F.11SCE Northern Area

The total capacity of resources, by resource type, selected with Full Capacity Deliverability Status (FCDS) as well as those selected as Energy Only (EO) in the SCE Northern interconnection area are listed in Table F.11-1. The portfolios in the interconnection area are comprised of solar, wind (in-state), battery storage, long duration energy storage, biomass/biogas and distributed solar resources. All portfolio resources are modeled in policy-driven assessments except in the on-peak deliverability assessment in which only FCDS resources are modeled.

Table F.11-1: SCE Northern Interconnection Area – Base and Sensitivity Portfolios by Resource Types (FCDS, EO and Total)

Resource Type	Base Portfolio			Sensitivity Portfolio		
	FCDS	EO	Total	FCDS	EO	Total
Solar	1,751	4,505	6,256	3,107	7,079	10,186
Wind – In State	275	-	275	281	-	281
Wind – Out-of-State (Existing TX)	-	-	-	-	-	-
Wind – Out-of-State (New TX)	-	-	-	-	-	-
Li Battery	4,550	-	4,550	6,033	-	6,033
Geothermal	-	-	-	-	-	-
Long Duration Energy Storage (LDES)	500	-	500	500	-	500
Biomass/Biogass	14	-	14	14	-	14
Distributed Solar	3	-	3	3	-	3
<b>Total</b>	<b>7,093</b>	<b>4,505</b>	<b>11,598</b>	<b>9,987</b>	<b>7,079</b>	<b>16,867</b>

Table F.11-2 shows adjustments to the base portfolio in the SCE Northern Interconnection Area made by CPUC staff to account for allocated TPD and additional in-development resources identified.

Table F.11-2: SCE Northern Interconnection Area – Adjustments to the base portfolio to account for adjustments to in-development resources and TPD allocations

	FCDS (MW)	EO (MW)	Total (MW)
Solar	-149	212	63
Wind – In State	6	-	6
Wind – Out-of-State (Existing TX)	-	-	-
Wind – Out-of-State (New TX)	-	-	-
Wind - Offshore	-	-	-
Li Battery	69	-	69
Geothermal	-	-	-
Long Duration Energy Storage (LDES)	-	-	-
Biomass/Biogass	-	-	-
Distributed Solar	-	-	-
<b>Total</b>	<b>-74</b>	<b>212</b>	<b>138</b>

The resources as identified in the CPUC busbar mapping for the SCE Northern interconnection area are illustrated on the single-line diagram in Figure F.11-1.

Figure F.11-1: SCE Northern Interconnection Area – Mapped<sup>21</sup> Base Portfolio

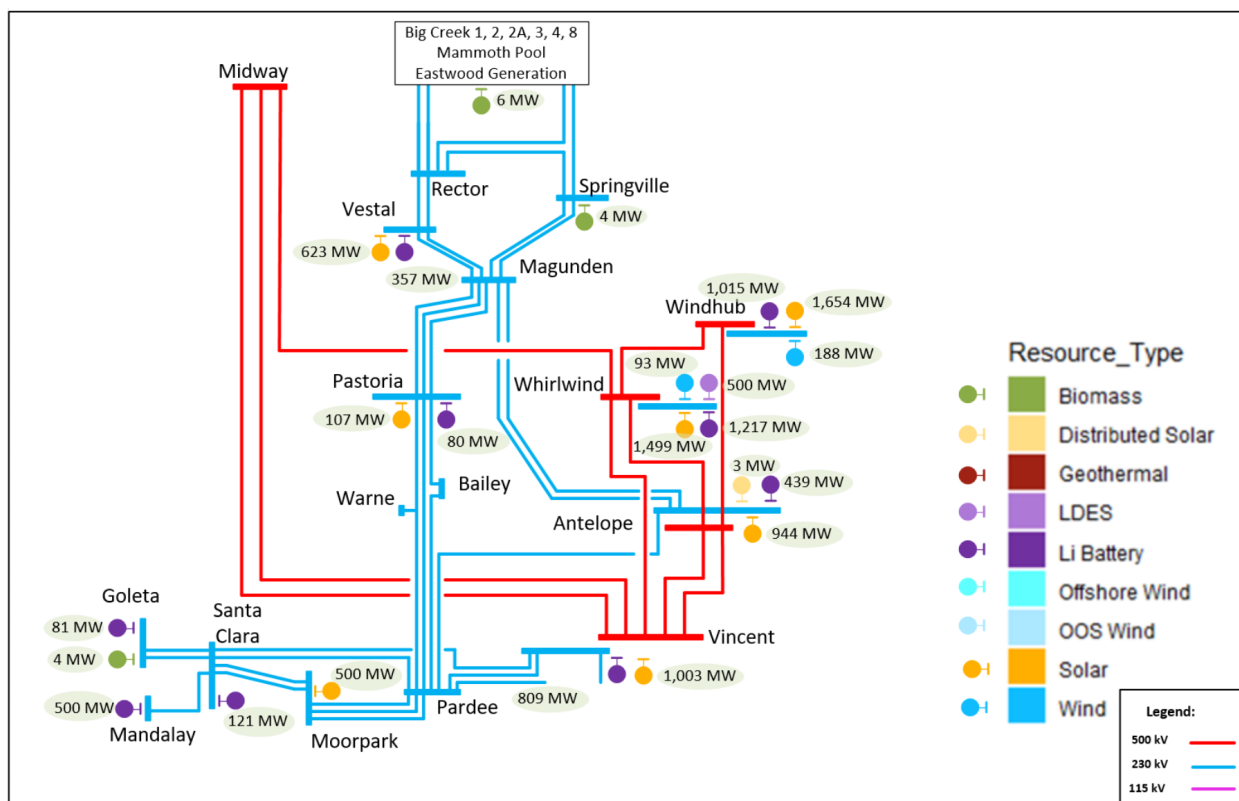

### F.11.1 On-peak results

#### Windhub 500/230 kV Transformer Constraint

The deliverability of FC resources interconnecting at Windhub 230 kV bus is limited by thermal overloading of the 500/230 kV transformers under Category P1 conditions as shown in Table F.11-3. The constraint is identified in the base and sensitivity portfolios under the HSN condition. In the case of the Base Portfolio, 108 MW of capacity resources will be undeliverable without mitigation as shown in Table F.11-4. The constraint can be mitigated by the planned Windhub CRAS.

Table F.11-3: Windhub 500/230 kV transformer deliverability constraint

Overloaded Facility	Contingency	Condition	Loading (%)	
			Base	Sensitivity
Windhub #3 or #4 500/230 kV transformer*	Windhub #3 or #4 500/230 kV transformer	HSN	108%	109%

\* Depending on which Windhub 230 kV bus, Bus A or Bus B, generic portfolio resources are mapped to Windhub #1 and #2 500/230 kV transformer could be overloaded instead of the #3 and #4 transformers.

<sup>21</sup> Mapped base portfolio includes the adjustments to the base portfolio made by CPUC staff in the SCE Northern Interconnection Area to account for allocated TPD and additional in-development resources identified.

Table F.11-4: Windhub 500/230 kV transformer constraint summary

Affected transmission zones		Tehachappi area – Windhub 230 kV	
		Base	Sensitivity
Generic portfolio MW behind the constraint (installed FCDS capacity)		0	35 MW
Generic battery storage portfolio MW behind the constraint (installed FCDS capacity)		0	0
Deliverable generic portfolio MW w/o mitigation (Installed FCDS capacity)		N/A	0
Total undeliverable baseline and portfolio MW (Installed FCDS capacity)		108 MW	149 MW
Mitigation Options	RAS	Planned Windhub CRAS	
	Re-locate portfolio battery storage (MW)	Not applicable or needed	
	Transmission upgrade including cost	Not Needed	
Recommended Mitigation		Planned Windhub CRAS	

### F.11.2 Off-peak results

Wind and solar resources in the SCE Northern area are subject to curtailment in the base and/or sensitivity portfolio due to loading constraints identified in Table F.11-5 under normal and/or contingency conditions, which are further discussed below.

Table F.11-5: SCE Northern area off-peak deliverability constraints

Overloaded Facility	Contingency	Loading (%)	
		Base	Sensitivity
Windhub 500/230 kV #1 & #2	Windhub 500/230 kV #1 or #2	109%	110%
Windhub 500/230 kV #3 & #4	Windhub 500/230 kV #3 or #4	<100%	145%
Whirlwind 500/230 kV Tr.	Base Case	<100%	105%
	Whirlwind 500/230 kV Tr.	102%	132%
Antelope–Vincent 500 kV #1 & #2	Antelope–Vincent 500 kV #1 or #2	<100%	103%
Midway–Whirlwind 500 kV (PG&E)	Base Case	<100%	128%
Midway–Whirlwind 500 kV (SCE)	Vincent–Whirlwind 500 kV	<100%	113%
	Antelope–Whirlwind 500 kV	<100%	107%
	Antelope–Windhub 500 kV	<100%	104%
	Antelope–Vincent #1 or #2	<100%	103%

**Windhub 500/230 kV transformers off-peak deliverability constraint**

Wind and solar resources interconnecting to Windhub 230 kV buses are subject to curtailment in the base and sensitivity portfolios due to loading limitations of the Windhub 500/230 kV transformers under category P1 conditions as shown in Table F.11-6. Pre-contingency curtailment can be avoided by relying on the planned Windhub CRAS.

Table F.11-6: Windhub 500/230 kV transformers off-peak deliverability constraint summary

Affected renewable transmission zones		Tehachapi (Windhub 230 kV)	
		Base	Sensitivity
Generic portfolio MW behind the constraint (Installed capacity)		361 MW	1680 MW
Energy storage portfolio MW behind the constraint (Installed capacity)		361 MW	500 MW
Renewable curtailment without mitigation (MW) (Installed capacity)		306 MW	814 MW
Mitigation Options:	Portfolio ES (in charging mode) (MW) <sup>22</sup>	135 MW	Not adequate
	RAS	Planned Windhub CRAS	
	Additional battery storage (MW)	Not needed	
	Transmission upgrades	Not needed	
Recommended Mitigation		Planned Windhub CRAS	

**Whirlwind 500/230 kV transformers off-peak deliverability constraint**

Wind and solar resources interconnecting to Whirlwind 230 kV bus are subject to curtailment in the base and sensitivity portfolios due to loading limitations of the Whirlwind 500/230 kV transformers under normal and/or category P1 conditions as shown in Table F.11-7. Pre-contingency curtailment can be avoided by dispatching energy storage in charging mode or in the case of the base portfolio by relying on the planned Whirlwind RAS.

<sup>22</sup> The Portfolio energy storage (in charging mode) amount is the amount needed to mitigate the constraint after baseline battery storage is fully utilized.

Table F.11-7: Whirlwind 500/230 kV transformers off-peak deliverability constraint summary

Affected renewable transmission zones		Tehachapi (Whirlwind 230 kV)	
		Base	Sensitivity
Generic portfolio MW behind the constraint (Installed capacity)		950 MW	2,807 MW
Energy storage portfolio MW behind the constraint (Installed capacity)		859 MW	
Renewable curtailment without mitigation (MW) (Installed capacity)		146 MW	1,214 MW
Mitigation Options:	Portfolio ES (in charging mode) (MW) <sup>23</sup>	Not needed	5 MW
	RAS	Planned Whirlwind RAS	Not applicable for N-0 overload, exceeds P1 limit
	Additional battery storage (MW)	Not needed	
	Transmission upgrades	Not needed	
Recommended Mitigation		Planned Whirlwind RAS or baseline storage charging	Baseline and generic storage charging

**Antelope–Vincent 500 kV off-peak deliverability constraint**

Wind and solar resources in SCE Northern area are subject to curtailment in the sensitivity portfolio due to loading limitations on either Antelope–Vincent 500 kV line under category P1 conditions as shown as shown in Table F.11-8. Pre-contingency curtailment can be avoided by dispatching energy storage in charging mode. As such, no other solutions were found to be necessary.

<sup>23</sup> The Portfolio energy storage (in charging mode) amount is the amount needed to mitigate the constraint after baseline battery storage is fully utilized.

Table F.11-8: Antelope–Vincent 500 kV lines off-peak deliverability constraint summary

Affected renewable transmission zones		SCE Northern area	
		Base	Sensitivity
Generic portfolio MW behind the constraint (Installed capacity)		N/A	7,696 MW
Energy storage portfolio MW behind the constraint (Installed capacity)		N/A	2,098 MVA
Renewable curtailment without mitigation (MW) (Installed capacity)		0 MW	465 MW
Mitigation Options:	Portfolio ES (in charging mode) (MW) <sup>24</sup>	Not needed	Not needed (Baseline storage is sufficient)
	RAS	Not needed	Not needed
	Additional battery storage (MW)	Not needed	Not needed
	Transmission upgrades	Not needed	Not needed
Recommended Mitigation		Not needed	Energy storage charging

### Midway–Whirlwind 500 kV line off-peak deliverability constraint

Wind and solar resources in southern California are subject to curtailment in the sensitivity portfolio due to loading limitations of on PG&E's portion of the Midway–Whirlwind 500 kV line under normal conditions and on SCE's portion of the line under category P1 conditions as shown above. 2,188 MW of portfolio resources were curtailed to mitigate the overload as shown in Table F.11-9. The constraint occurs during periods of high renewable output and heavy south to north transfers on Path 26. Renewable curtailment can be avoided by dispatching energy storage in charging mode. Since the constraint occurs under normal system conditions, RAS is not a viable mitigation. The transmission alternatives below were also considered to mitigate the off-peak deliverability constraint as well as the heavy congestion on Path 26 and the Midway–Whirlwind 500 kV line that is identified in chapter 4.

<sup>24</sup> The Portfolio energy storage (in charging mode) amount is the amount needed to mitigate the constraint after baseline battery storage is fully utilized.

Table F.11-9: Midway–Whirlwind 500 kV off-peak deliverability constraint summary

Affected renewable transmission zones		All of Southern California,	
		Base	Sensitivity
Generic portfolio MW behind the constraint (Installed capacity)		N/A	42,675 MW
Energy storage portfolio MW behind the constraint (Installed capacity)		N/A	14,346 MW
Renewable curtailment without mitigation (MW) (Installed capacity)		0 MW	2,188 MW
Mitigation Options:	Portfolio ES (in charging mode) (MW) <sup>25</sup>	Not needed	Not needed (baseline storage is sufficient)
	RAS	Not needed	Not applicable for N-0 overload
	Additional battery storage (MW)	Not needed	Not needed
	Transmission upgrades	Not needed	1. Re-rate PG&E'S segment of the Midway–Whirlwind 500 kV line and bypass the series capacitor on the line. 2. New Windhub to Midway 500 kV line (\$640 million)
Recommended Mitigation		Not needed	Baseline or generic storage charging

1. Increase the normal rating Midway–Whirlwind 500 kV line and/or bypass the series capacitor on the line

This option was considered in the 2021-2022 TPP and was recommended for further investigation in coordination with PG&E and SCE. The option involves increasing the normal rating of PG&E’s portion of the line, which is established to limit conductor normal loading to gain higher summer emergency rating. This change will only address the N-0 overloading on the line identified in this assessment. However, increasing the normal rating of the line could result reducing the 30-minute rating. In order to address the overload under emergency conditions bypassing the series capacitor on the line in addition to or instead of the normal rating increase is needed. The ISO in collaboration with PG&E and SCE will continue to investigate the feasibility of this option.

<sup>25</sup> The Portfolio energy storage (in charging mode) amount is the amount needed to mitigate the constraint after baseline battery storage is fully utilized.

## 2 New Windhub-Midway 500 kV line

A new Windhub-Midway 500 kV line was also considered to address the off-peak deliverability constraint and the severe congestion associated with Path 26 and the Midway-Whirlwind 500 kV line identified in production simulation studies. In addition the new line will address the concern associated with the loss of the large amount of generation connecting to Windhub in the event of the loss of the two 500 kV lines that connect the substation to the rest of the system.

The alternative considered involves installing approximately 95 miles of 500 kV line and series compensation at both Midway and Windhub substations at an estimated cost of \$640 million.

The economic benefits of the new Windhub-Midway 500 kV line was evaluated using production simulation. The results, which are presented in chapter 4, did not find the line to be economic at this time.

Based on the above considerations, dispatching available energy storage in charging mode is found to be the preferred solution to address the off-peak deliverability constraint at this time.

### F.11.3 Conclusion and recommendation

The SCE Northern area base and sensitivity portfolio deliverability assessment identified on-peak and off-peak deliverability constraints. Since the constraints can be addressed using RAS or energy storage charging as applicable, transmission upgrades were not found to be needed in the area in the current planning cycle.

## F.12 SCE North of Lugo Area

The total capacity of resources, by resource type, selected with Full Capacity Deliverability Status (FCDS) as well as those selected as Energy Only (EO) in the SCE North of Lugo interconnection area are listed in Table F.12-1. The portfolios in the interconnection area are comprised of solar, battery storage, geothermal, biomass/biogass and distributed solar resources. All portfolio resources are modeled in policy-driven assessments except in the on-peak deliverability assessment in which only FCDS resources are modeled.

Table F.12-1: SCE North of Lugo Interconnection Area – Base and Sensitivity Portfolios by Resource Types (FCDS, EO and Total)

Resource Type	Base Portfolio			Sensitivity Portfolio		
	FCDS	EO	Total	FCDS	EO	Total
Solar	385	1,071	1,456	770	2,411	3,181
Wind – In State	-	-	-	100	-	100
Wind – Out-of-State (Existing TX)	-	-	-	-	-	-
Wind – Out-of-State (New TX)	-	-	-	-	-	-
Wind – Offshore	-	-	-	-	-	-
Li Battery	869	-	869	1,904	-	1,904
Geothermal	40	-	40	48	-	48
Long Duration Energy Storage (LDES)	-	-	-	-	-	-
Biomass/Biogass	3	-	3	3	-	3
Distributed Solar	7	-	7	7	-	7
<b>Total</b>	<b>1,304</b>	<b>1,071</b>	<b>2,375</b>	<b>2,962</b>	<b>2,411</b>	<b>5,243</b>

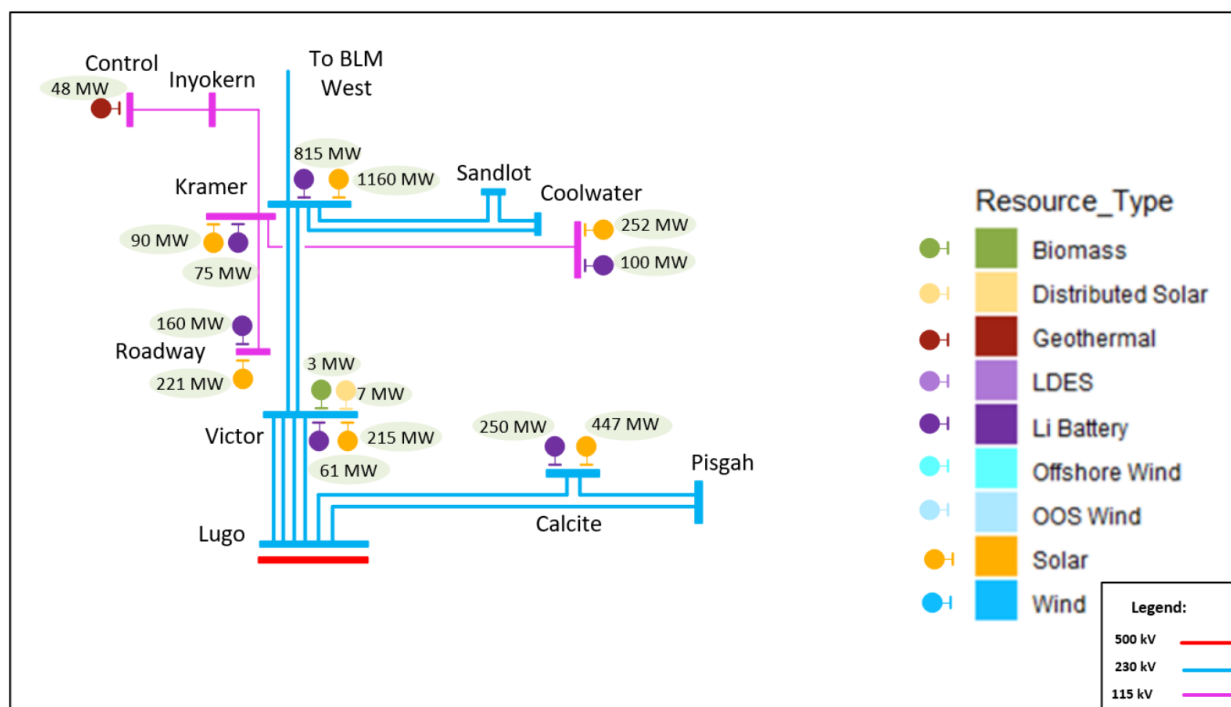

Table F.12-2 shows adjustments to the base portfolio made in the North of Lugo Interconnection Area made by CPUC staff to account for allocated TPD and additional in-development resources identified. The resources as identified in the CPUC busbar mapping for the SCE North of Lugo interconnection area are illustrated on the single-line diagram in Figure F.12-1.

Table F.12-2: SCE North of Lugo Interconnection Area – Adjustments to the base portfolio to account for adjustments to in-development resources and TPD allocations

	FCDS (MW)	EO (MW)	Total (MW)
Solar	477	452	929
Wind – In State	-	-	-
Wind – Out-of-State (Existing TX)	-	-	-
Wind – Out-of-State (New TX)	-	-	-
Wind - Offshore	-	-	-
Li Battery	592	-	592
Geothermal	8	-	8
Long Duration Energy Storage (LDES)	-	-	-
Biomass/Biogass	-	-	-
Distributed Solar	-	-	-
<b>Total</b>	<b>1,077</b>	<b>452</b>	<b>1,529</b>

Figure F.12-1: SCE North of Lugo Interconnection Area – Mapped<sup>26</sup> Base Portfolio



<sup>26</sup> Mapped base portfolio includes the adjustments to the base portfolio made by CPUC staff in the SCE North of Lugo Interconnection Area to account for allocated TPD and additional in-development resources identified.

## F.12.1 On-peak results

### Lugo–Victor–Kramer Corridor Constraints

The Lugo–Victor–Kramer deliverability constraints, which are comprised of the constraints included in Table F.12-3 that are grouped together to facilitate development of a common transmission upgrade, affect deliverability of capacity resources in the NOL area due to thermal overloading of the 500/230 kV and 230/115 kV transformers as well as 230 kV and 115 kV lines in the area under contingency conditions. Deliverability of resources located north of Victor is also limited by voltage instability and thermal overloading due to the category P7 contingency of Kramer–Victor 230 kV #1 & #2 lines. The constraints are identified in both the base and sensitivity portfolios as shown in the table. Up to 1194 MW of capacity resources in the base portfolio will be undeliverable without mitigation. Table F.12-4 to Table F.12-6 provide the constraint summary for the more limiting constraints.

Table F.12-3: Lugo–Victor–Kramer Corridor on-peak deliverability constraints

Overloaded Facility	Contingency	Loading (%) (HSN/SSN)	
		Base	Sensitivity
Lugo 500/230 Tr. 1 & 2	Lugo 500/230 Tr. No. 1 or 2 (P1)	125%/126%	143%/130%
Lugo–Victor 230 kV 1, 2, 3 & 4	Two Lugo–Victor 230 kV lines (P7)	106%/113%	117%/113%
Roadway–Victor 115 kV	Kramer–Victor 230 kV #1 & 2 (P7)	Diverged (150/156%)	Diverged (154%/151%)
Kramer–Victor 115 kV		Diverged (147%/167%)	Diverged (153%/165%)
Kramer–Roadway 115 kV		Diverged (143%/165%)	Diverged (150%/164%)
Kramer 230/115 Tr. 1 & 2		188%/Diverged(188%)	195%/Diverged (193%)
Kramer–Victor 230 kV #1 & 2	Kramer–Victor 230 kV #1 or 2(P1)	95%/110%	99%/108%

Table F.12-4: On-peak Lugo 500/230 kV transformer constraint summary

Affected transmission zones		North of Lugo Area	
		Base (SSN)	Sensitivity (SSN)
Generic portfolio MW behind the constraint (installed FCDS capacity)		466 MW	1,860 MW
Generic battery storage portfolio MW behind the constraint (installed FCDS capacity)		400 MW	1,132 MW
Deliverable generic portfolio MW w/o mitigation (Installed FCDS capacity)		0 MW	821 MW
Total undeliverable baseline and portfolio MW (Installed FCDS capacity)		944 MW	1,092 MW
Mitigation Options	RAS	Not sufficient (see discussion below)	
	Re-locate portfolio battery storage (MW)	Not applicable	
	Transmission upgrade including cost	1. Add 3rd Lugo 500/230 kV Transformer (\$70M) 2. Lugo–Kramer 500 kV development (\$700M)	
Recommended Mitigation		Add 3rd Lugo 500/230 kV Transformer (\$70M)	

Table F.12-5: On-peak Lugo–Victor 230 kV corridor constraint summary

Affected transmission zones		North of Victor Area including Victor	
		Base (SSN)	Sensitivity (SSN)
Generic portfolio MW behind the constraint (installed FCDS capacity)		164 MW	1,191 MW
Generic battery storage portfolio MW behind the constraint (installed FCDS capacity)		150 MW	692 MW
Deliverable generic portfolio MW w/o mitigation (Installed FCDS capacity)		0	843 MW
Total undeliverable baseline and portfolio MW (Installed FCDS capacity)		354 MW	401 MW
Mitigation Options	RAS	Not sufficient (see discussion below)	
	Re-locate portfolio battery storage (MW)	Not applicable	
	Transmission upgrade including cost	1. Reconductor Lugo–Victor 230 kV No. 1, 2, 3 & 4 lines (\$112M) 2. Lugo–Kramer 500 kV development (\$700M)	
Recommended Mitigation		Reconductor Lugo–Victor 230 kV No. 1, 2, 3 & 4 lines (\$112M)	

Table F.12-6: On-peak Kramer–Victor #1 & 2 230 kV contingency voltage stability and overload constraint summary

Affected transmission zones		North of Victor, Kramer–Coolwater Area	
		Base (SSN)	Sensitivity (SSN)
Generic portfolio MW behind the constraint (installed FCDS capacity)		150 MW	954 MW
Generic battery storage portfolio MW behind the constraint (installed FCDS capacity)		150 MW	533 MW
Deliverable generic portfolio MW w/o mitigation (Installed FCDS capacity)		0 MW	26 MW
Total undeliverable baseline and portfolio MW (Installed FCDS capacity)		1,194 MW	1,251 MW
Mitigation Options	RAS	Not sufficient (see discussion below)	
	Re-locate portfolio battery storage (MW)	Not sufficient or applicable	
	Transmission upgrade including cost	1. Rebuild/build Kramer–Victor 115 kV lines to 230 kV (\$300 M) 2. Lugo–Kramer 500 kV development (\$700M)	
Recommended Mitigation		Rebuild/build Kramer–Victor 115 kV lines to 230 kV(\$300 M)	

RAS, reducing portfolio battery storage and transmission alternatives were considered to address the Lugo–Victor–Kramer Corridor constraints. Removing battery storage is not considered a valid option because it is not sufficient to address the constraints and would limit mapping of battery storage and hybrid/collocated resources in the large geographic area covered by the constraints. Expanding existing RAS to include portfolio resources is also not considered a viable alternative as explained below, which leaves transmission upgrade as the solution for the deliverability constraints identified in the Lugo–Victor–Kramer Corridor.

The NOL area heavily relies on increasingly complex and overlapping RAS to ensure deliverability of existing and in-development resources and to protect reliability of the system. Currently, three RASs are in operation in the NOL area: High Desert Power Project (HDPP) RAS, Mojave Desert RAS and Bishop RAS. A Calcite area RAS is also planned and will integrate resources connecting to Calcite and Pispah. SCE currently plans to merge the Mojave Desert RAS, the HDPP RAS, the planned Calcite RAS and eventually the Bishop RAS into a NOL CRAS that will monitor all of the contingencies, affected elements and generator output that is currently monitored by the individual RASs. Some of the contingencies that the existing RAS are designed to protect against are contingencies that could cause instability.

Due to the planned addition of resources without the necessary transmission upgrades, the currently planned system is already going beyond the RAS design guidelines in the ISO Planning Standards. As a result, expanding the RAS to include portfolio resources to address the deliverability constraints identified above is not a valid option. A total of about 3325 MW,

3003 MW and 2338 MW of existing, in-development and TPD allocated resources included in the base portfolio will need to be connected to the NOL area RAS to mitigate the Lugo 500/230 kV, Lugo–Victor 230 kV corridor and Victor–Kramer 230 kV corridor deliverability and reliability constraints, respectively. The base resource portfolio goes beyond the capability of the existing system and trying to expand the RAS would result in needing to add more generation projects to it. ISO RAS guidelines ISO-G-RAS1 and ISO-G-RAS3 state that RAS should be designed for simple operation to trip a fixed set of generation under specific contingencies and the total net amount of generation tripped by a RAS should not exceed 1150 MW for single contingencies and 1400 MW for multiple contingencies. The planned RAS have already gone beyond these guidelines in order to integrate planned renewable energy and energy storage resources and maximize their deliverable capacity. Adding more generation projects or portfolio resources without transmission upgrades would cause long term operational complexities and reliability impacts.

In addition, the Mohave Desert RAS is already planned to drop generation for 8 contingencies in the next few years when seven new and repowering projects are expected to be added, which exceeds the 6 contingencies allowed by ISO Planning Standard guideline ISO-G-RAS2. Also, both the HDPP RAS and Mojave Desert RAS are currently relied up on to protect the Lugo 500/230 kV transformers during a single outage involving either transformer. Development of planned or generic resources connecting to Calcite substation as envisaged in the base portfolio and Pisgah substation in the sensitivity portfolio will require that the planned Calcite area RAS also be designed to act to protect the Lugo 500/230 kV transformers. Similarly, with the addition of more in-development and portfolio resources upstream of Victor as modeled in the base and sensitivity portfolios, the Lugo–Victor lines that are currently only protected by the HDPP RAS, will need to be protected by the Mojave Desert RAS as well. The overlapping design of the HDPP RAS, the Mojave Desert RAS, and the planned Calcite area RAS is inconsistent with ISO Planning Standard RAS guideline ISO-G-RAS2.

Based on the above considerations, expanding the existing RAS to include portfolio resources was not found to be a viable alternative to mitigate the deliverability constraints identified in the Lugo–Victor–Kramer corridor. Transmission upgrades are needed to address the deliverability constraints. In addition to supporting the deliverability of portfolio resources, upgrading the Lugo–Victor–Kramer corridor will improve reliability and alleviate congestion and renewable curtailment. Transmission upgrades in the area improve reliability by addressing the thermal overload, voltage and stability issues identified in chapter 2 under normal and contingency conditions. The high congestion and renewable curtailment in the area identified in chapter 4 and the results of the production cost simulation performed to quantify the production cost savings associated with the transmission upgrade alternatives identified to address the Lugo–Victor–Kramer corridor deliverability constraints are discussed below.

The following transmission alternatives were considered to address the Lugo–Victor–Kramer Corridor deliverability constraints.

**Alternative 1: Lugo–Victor–Kramer 230 kV upgrades**

The total cost of this alternative is \$482 million and includes:

- A 3<sup>rd</sup> Lugo 500/230 kV transformer (\$70 million) ; ISD - December 2027;
- Reconductoring Lugo–Victor 230 kV No. 1, 2, 3 & 4 lines (\$112 million); ISD - December 2027; and
- Rebuilding Kramer–Victor 115 kV lines for 230 kV operation and looping the old segment of Kramer–Victor 115 kV line into Roadway (\$300 million); ISD - December 2032.

This alternative is based on pre-cluster 14 area delivery network upgrades (ADNUs) identified in the NOL area, which are included in the ISO’s transmission capability estimates whitepaper. The only change is that the reconductoring of Victor–Kramer 230 kV lines is replaced with the conversion of the Kramer–Victor 115 kV lines to 230 kV to address the severe thermal loading and stability impact of the category P7 loss of the existing Victor–Kramer 230 kV lines.

**Alternative 2: Lugo–Kramer 500 kV development**

This alternative involves building a new 500 kV substation at Kramer with two 500/230 kV transformers and a new 500 kV transmission line from Kramer to Lugo. The cost of this alternative is \$700 million and has an estimated ISD of June 31, 2033. This alternative is based on the area delivery network upgrade (ADNU) identified in the NOL area in the generation interconnection queue cluster 14 with some modification.

**Comparison of the transmission alternatives considered**

Table F.12-7 provides assessment of the transmission alternatives for Lugo–Victor–Kramer Corridor constraint. The assessment is based on the 2035 HE sensitivity portfolio under both the HSN and SSN scenarios.

Table F.12-7: Assessment of Lugo–Victor–Kramer Corridor constraint mitigation alternatives

Overloaded Facility	Contingency	Loading (%) (HSN/SSN)		
		No mitigation	Alt 1	Alt 2
Lugo 500/230 Tr. 1 & 2	Lugo 500/230 Tr. No. 1 or 2 (P1)	143%/130%	<100%	<100%
Lugo–Victor 230 kV 1, 2, 3 & 4	Two Lugo–Victor 230 kV lines (P7)	117%/113%	<100%	<100%
Roadway–Victor 115 kV	Kramer–Victor 230 kV #1 &2 (P7)	Diverged (154%/151%)	<100%	<100%
Kramer–Victor 115 kV		Diverged (153%/165%)	<100%	<100%
Kramer–Roadway 115 kV		Diverged (150%/164%)	<100%	<100%
Kramer 230/115 Tr. 1 & 2		195%/ Diverged(193%)	<100%	<100%
Kramer–Victor 230 kV #1 & 2	Kramer–Victor 230 kV #1 or 2 (P1)	99%/108%	<100%	<100%

**Incremental Capacity due to the transmission upgrade alternatives**

The generation queue cluster 14 Phase I HSN study case was used to assess the on-peak incremental transmission capacity provided by the transmission upgrade alternatives. The results are provided in Table F.12-8 based on deliverability study resource output assumptions.

Table F.12-8: Incremental deliverable capacity in MW due to alternatives (study output amount)

Constraint	Alternative 1 (Kramer – Lugo 230 kV Upgrade)	Alternative 2 (Kramer – Lugo 500 kV Upgrade)
Lugo 500/230 kV constraint	1,306	1,577
Lugo–Victor 230 kV Constraint	1,337	1,923
Victor–Kramer 230 kV Constraint	1004+	1004+

**Economic considerations**

The production simulation results presented in chapter 4 indicate that the NOL area has significant congestion. Detailed economic assessment was performed for the two policy driven transmission upgrade alternatives. While neither alternative has sufficient economic benefit to offset its cost, the results indicate that Alternative 1 and Alternative 2 have present value production cost savings of \$214 million and \$260 million, or 0.340 and 0.286 benefit to cost ratio, respectively. The analysis does not include capacity benefits that may arise should existing or in-development energy only or PCDS resources in the area become FCDS due to the incremental capacity provided by the transmission upgrades. Details of economic assessment results can be found in chapter 4 and appendix G.

**Overall comparison of the Lugo–Victor–Kramer corridor transmission upgrade alternatives.**

Table F.12-9 provides an overall comparison of the two alternatives considered to address the Lugo–Victor–Kramer corridor deliverability constraints.

Table F.12-9: Overall comparison of the Lugo–Victor–Kramer corridor transmission upgrade alternatives

	230 kV Upgrade	500 kV development
Cost	\$482 million	\$700 million
Portfolio deliverability performance	Good	Better
Incremental deliverable MW due to upgrade (study output amount)	1,004 MW to 1,337 MW	1004 MW to 1923 MW
PV of production cost savings	\$214 million or 0.340 BCR	\$260 million or 0.286 BCR
Longer term considerations	Better if longer term resource development in the area is not expected to be high	Better if longer term resource development in the area is expected to be high

The Lugo–Victor–Kramer 230 kV upgrade is recommended based on its lower cost and satisfactory performance in the base and sensitivity portfolio analysis.

### Control–Silver Peak 55kV deliverability constraints

Control–Silver Peak 55 kV deliverability constraints, which are comprised of the constraints included in Table F.12-10, affect deliverability of capacity resources in the Control and Silver Peak areas due to thermal overloading of the non-ISO controlled Silver Peak PST under normal conditions and 115 kV and 55 KV facilities in the area under contingency conditions. The most limiting constraint is the Silver Peak PST, which occurs in both the base and sensitivity portfolios. The constraint is due to the 53 MW MIC expansion request associated with the Silver Peak inter-tie which exceeds the rating of the 17 MVA PST. Reducing the MIC expansion to be within the rating of the PST addresses all of the constraints. It is noted that the MIC expansion request is also behind the Lugo–Victor–Kramer Corridor Constraints described above. As a result the MIC expansion is contingent on approval and development of the upgrades recommended to mitigate the Lugo–Victor–Kramer Corridor Constraints. Table F.12-11 provides the Control–Silver Peak constraint summary for the most limiting constraint.

Table F.12-10: Control–Silver Peak 55 kV deliverability constraints

Overloaded Facility	Contingency	Loading (%) (HSN)	
		Base	Sensitivity
Silver peak PST (See Note)*	Base case	318%	318%
Control–Tap 189 115 kV	Control–Inyokern 115 kV #2 (P1)	106%	<100
Silver Peak–Tap 642 55 kV	Control–Silver Peak C 55 kV (P1)	127%	132%
NEVBD501 58 kV to 55 kV	Control–Silver Peak A 55 kV (P1)	134%	142%

Note: The requested 53 MW Silver Peak BG MIC exceeds the 17 MVA normal rating of the non-ISO controlled Silver Peak PST. Reducing the requested MIC expansion to be within the rating of the PST addresses all of the overloads.



Table F.12-11: Control–Silver Peak 55/57.5 kV constraint summary

Affected transmission zones		Control–Silver Peak area	
		Base	Sensitivity
Generic portfolio MW behind the constraint (installed FCDS capacity)		0	0
Generic battery storage portfolio MW behind the constraint (installed FCDS capacity)		0	0
Deliverable generic portfolio MW w/o mitigation (Installed FCDS capacity)		N/A	N/A
Total undeliverable baseline and portfolio MW (Installed FCDS capacity)		38 MW (MIC request)	38 MW (MIC request)
Mitigation Options	RAS	Not applicable for N-0 overloads	
	Re-locate portfolio battery storage (MW)	Not applicable	
	Transmission upgrade including cost	Not needed	
	Other	Reduce the requested MIC expansion to 15 MW	
Recommended Mitigation		Reduce requested MIC expansion to 15 MW	

**Lugo–Calcite–Pisgah 230 kV Corridor Constraints**

The Lugo–Calcite–Pisgah 230 kV deliverability constraints, which are comprised of the constraints included in Table F.12-12, affect deliverability of capacity resources connected to Calcite and Pisgah due to overloading of the 230 kV lines in the corridor. The Calcite–Lugo 230 kV line is the most limiting constraint and is overloaded under contingency conditions in the base portfolio and under normal conditions in the sensitivity portfolio. 64 MW of capacity resources in the base portfolio and 295 MW in the sensitivity portfolio will be undeliverable without mitigation. Table F.12-13 provides the constraint summary for the most limiting constraint.

Table F.12-12: Lugo–Calcite–Pisgah 230 kV Corridor on-peak deliverability constraints

Overloaded Facility	Contingency	Loading (%) (HSN)	
		Base	Sensitivity
Calcite–Lugo 230 kV	Base case	95%	132%
	Pisgah–Lugo 230 kV (P1)	116%	171%
	Eldorado–Lugo 500 kV (P1)	105%	147%
	Lugo–Mohave 500 kV (P1)	102%	140%
	Eldorado–Mohave 500 kV (P1)	98%	139%
Pisgah–Lugo 230 kV	Calcite–Lugo 230 kV (P1)	<100%	143%
	Pisgah–Calcite 230 kV (P1)	<100%	102%
Pisgah–Calcite 230 kV	Pisgah–Lugo 230 kV (P1)	<100%	103%

Table F.12-13: On-peak Lugo–Calcite–Pisgah 230 kV constraint summary

Affected transmission zones		Calcite–Pisgah area	
		Base	Sensitivity
Generic portfolio MW behind the constraint (installed FCDS capacity)		302 MW	669 MW
Generic battery storage portfolio MW behind the constraint (installed FCDS capacity)		250 MW	440 MW
Deliverable generic portfolio MW w/o mitigation (Installed FCDS capacity)		237 MW	374 MW
Total undeliverable baseline and portfolio MW (Installed FCDS capacity)		65 MW	295 MW
Mitigation Options	RAS	Planned Calcite Area RAS expanded to include portfolio resources and the Eldorado/Mohave-Lugo 500 kV corridor contingencies	Not applicable for N-0 overload
	Re-locate portfolio battery storage (MW)	65 MW (collocated with solar)	295 MW (collocated with solar)
	Transmission upgrade including cost	Not needed	<ol style="list-style-type: none"> <li>1. Rebuild Calcite–Lugo 230 kV line (\$172M)</li> <li>2. Rebuild Calcite–Lugo 230 kV line to 500 kV standards (\$243M)</li> <li>3. Develop a 500 kV substation at Pisgah and associated upgrades (\$250M)</li> </ol>
Recommended Mitigation		Planned Calcite area RAS	To be evaluated in the next planning cycle

The planned Calcite area RAS expanded to include portfolio resources and the Eldorado/Mohave–Lugo 500 kV corridor contingencies can address the constraint in the case of the base portfolio. Since the Calcite–Lugo 230 kV line is overloaded under N-0 conditions in the the sensitivity portfolio, RAS is not a valid mitigation. Three transmission upgrade alternatives are identified for the sensitivity portfolio to address the deliverability constraint as shown in Table F.12-13. The transmission upgrades will be evaluated in the next planning cycle. There is interaction between the Lugo–Calcite–Pisgah 230 kV corridor, which is currently considered part of the North of Lugo area due to the impact of resources connecting to the Calcite (planned) and Pisgah substations, and the East of Pisgah area due to the Lugo 500/230 kV transformers, and the East of Pisgah area due to the Lugo–Eldorado/Mohave 500 kV corridor that parallels the 230 kV lines. As such, transmission developments in the two areas need to be coordinated.

**F.12.2 Off-peak results**

**Lugo–Victor–Kramer Corridor Constraints**

Wind and solar resources in the NOL area are subject to curtailment in the base and sensitivity portfolios due to loading limitations on the 500/230 kV transformation, 230 kV and 115 kV facilities along the Lugo–Victor–Kramer corridor under normal and contingency conditions as shown in Table F.12-14. The Kramer–Victor 230 kV #1 &2 contingency also causes voltage collapse and severe overloads on multiple facilities due to the inability of the weak parallel 115 kV lines to support upstream resources. Many of the constraints affect both the base and sensitivity portfolios. Table F.12-15 to Table F.12-18 provide the constraint summary for the more limiting constraints including mitigation alternatives considered.

Table F.12-14: Lugo–Victor–Kramer corridor off-peak deliverability constraints

Overloaded Facility	Contingency	Loading (%)	
		Base	Sensitivity
Lugo 500/230 Tr. 1 & 2	Base Case	<100%	108%
Lugo 500/230 Tr. 1 & 2	Lugo 500/230 Tr. No. 1 or 2 (P1)	115%	173%
Victor–Lugo 230 kV 1, 2, 3 & 4	Base Case	<100%	103%
	Victor–Lugo 230 kV 1&2 or 3 & 4	<100%	152%
Kramer–Victor 230 kV #1 & 2	Base Case	<100%	143%
Kramer–Victor 230 kV #1 & 2	Kramer–Victor 230 kV 1 or 2 (P1)	119%	185%
Roadway–Victor 115 kV	Kramer–Victor 230 kV #1 &2 (P7)	Diverged (191%)	Diverged (261%)
Kramer–Victor 115 kV		Diverged (176%)	Diverged (260%)
Kramer–Roadway 115 kV		Diverged (168%)	Diverged (251%)
Kramer 230/115 Tr. 1 & 2		Diverged (175%)	Diverged (256%)
Coolwater–Dunn Siding 115 kV		Diverged (105%)	Diverged (181%)
Dunn Siding–Baker 115 kV		Diverged (105%)	Diverged (181%)
Baker–Mountain Pass 115 kV		<100%	Diverged (164%)
Victor 230/115 kV Tr. 2, 3 &4		<100%	Diverged (126%)
Mountain Pass–Ivanpah 115 kV		<100%	Diverged (126%)
Roadway–Victor 115 kV		Base Case	<100%
	Kramer–Victor 230 kV #1 or 2 (P1)	<100%	117%

Table F.12-15: Lugo 500/230 kV transformers off-peak deliverability constraint summary

Affected renewable transmission zones		Entire North of Lugo area	
		Base	Sensitivity
Generic portfolio MW behind the constraint (Installed capacity)		919 MW	3,272 MW
Energy storage portfolio MW behind the constraint (Installed capacity)		400 MW	1,132 MW
Renewable curtailment without mitigation (MW) (Installed capacity)		368 MW	1,594 MW
Mitigation Options:	Portfolio ES (in charging mode) (MW) <sup>27</sup>	Not needed	836 MW
	RAS	Not sufficient (see discussion in the on-peak assessment section). Also, not applicable for an N-0 overload	
	Additional battery storage (MW)	Not needed	
	Transmission upgrades	Same as on-peak	
Recommended Mitigation		The transmission upgrades recommended in the off-peak assessment	

Table F.12-16: Victor–Lugo 230 kV lines off-peak deliverability constraint summary

Affected renewable transmission zones		North of Victor area	
		Base	Sensitivity
Generic portfolio MW behind the constraint (Installed capacity)		N/A	2052 MW
Energy storage portfolio MW behind the constraint (Installed capacity)		N/A	692 MW
Renewable curtailment without mitigation (MW) (Installed capacity)		0	994 MW
Mitigation Options:	Portfolio ES (in charging mode) (MW) <sup>28</sup>	Not needed	294 MW
	RAS	Not needed	Not applicable for an N-0 overload
	Additional battery storage (MW)	Not needed	Not needed
	Transmission upgrades	Not needed	Same as on-peak
Recommended Mitigation		Not needed	The transmission upgrades recommended in the on-peak assessment

<sup>27</sup> The Portfolio energy storage (in charging mode) amount is the amount needed to mitigate the constraint after baseline battery storage is fully utilized.

<sup>28</sup> The Portfolio energy storage (in charging mode) amount is the amount needed to mitigate the constraint after baseline battery storage is fully utilized.

Table F.12-17: Kramer–Victor 230 kV contingency voltage stability and thermal loading off-peak deliverability constraint summary

Affected renewable transmission zones		North of Kramer, Kramer–Coolwater area	
		Base	Sensitivity
Generic portfolio MW behind the constraint (Installed capacity)		150 MW	1588 MW
Energy storage portfolio MW behind the constraint (Installed capacity)		150 MW	533 MW
Renewable curtailment without mitigation (MW) (Installed capacity)		995 MW	1,600 MW
Mitigation Options:	Portfolio ES (in charging mode) (MW) <sup>29</sup>	Not adequate	Not adequate
	RAS	Not sufficient (see discussion in the on-peak assessment section).	
	Additional battery storage (MW)	Not applicable due to on-peak constraints	
	Transmission upgrades	Same as on peak	Same as on-peak
Recommended Mitigation		The transmission upgrades recommended in the off-peak assessment	

Table F.12-18: Kramer–Victor 230 kV overload off-peak deliverability constraint summary

Affected renewable transmission zones		North of Kramer, Kramer–Coolwater area	
		Base	Sensitivity
Generic portfolio MW behind the constraint (Installed capacity)		150 MW	1,588 MW
Energy storage portfolio MW behind the constraint (Installed capacity)		150 MW	533 MW
Renewable curtailment without mitigation (MW) (Installed capacity)		246 MW	1,210 MW
Mitigation Options:	Portfolio ES (in charging mode) (MW) <sup>30</sup>	Not needed	Not adequate
	RAS	Not sufficient (see discussion in the on-peak assessment). Also, not applicable for an N-0 overload	
	Additional battery storage (MW)	Not applicable due to on-peak constraints	
	Transmission upgrades	The transmission upgrades recommended in the off-peak assessment	
Recommended Mitigation		The transmission upgrades recommended in the off-peak assessment	

<sup>29</sup> The Portfolio energy storage (in charging mode) amount is the amount needed to mitigate the constraint after baseline battery storage is fully utilized.

<sup>30</sup> The Portfolio energy storage (in charging mode) amount is the amount needed to mitigate the constraint after baseline battery storage is fully utilized.

Table F.12-19 provides assessment of the transmission alternatives for Lugo–Victor–Kramer Corridor constraint under off-peak conditions. The assessment is based on the 2035 HE sensitivity portfolio.

The results indicate that both alternatives address most of the issues identified without mitigation. The remaining overloads can be addressed by a much simplified RAS or energy storage charging. A comparison of the two alternatives indicates that the 500 kV alternative performs better in that:

- In the case of the 230 kV alternative, the upgraded Victor–Lugo 230 kV 1, 2, 3 & 4 lines are overloaded;
- In the case of the 230 kV alternative three contingencies caused six facilities to overload where as in the case of the 500 kV alternative a single contingency caused two facilities to overload; and
- The overloads in the case of the 230 kV alternative are more severe.

Table F.12-19: Assessment of transmission alternatives for Lugo–Victor–Kramer Corridor constraint under off-peak conditions

Overloaded Facility	Contingency	Loading (%) (Sensitivity portfolio)		
		No mitigation	Alt 1 (230 kV)	Alt 2 (500 kV)
Lugo 500/230 Tr. 1 & 2	Base Case	108%	<100%	<100%
Lugo 500/230 Tr. 1 & 2	Lugo 500/230 Tr. No. 1 or 2 (P1)	173%	<100%	<100%
Victor–Lugo 230 kV 1, 2, 3 & 4	Base Case	103%	<100%	<100%
	Victor–Lugo 230 kV 1&2 or 3 & 4	152%	108% <sup>(1)</sup>	<100%
Kramer–Victor 230 kV #1 & 2	Base Case	143%	<100%	<100%
Kramer–Victor 230 kV #1 & 2	Kramer–Victor 230 kV 1 or 2 (P1)	185%	<100%	<100%
Roadway–Victor 115 kV	Kramer–Victor 230 kV #1 & 2 (P7)	Diverged (261%)	<100%	<100%
Kramer–Victor 115 kV		Diverged (260%)	<100%	<100%
Kramer–Roadway 115 kV		Diverged (251%)	<100%	<100%
Kramer 230/115 Tr. 1 & 2		Diverged (256%)	<100%	<100%
Coolwater–Dunn Siding 115 kV		Diverged (181%)	<100%	<100%
Dunn Siding–Baker 115 kV		Diverged (181%)	<100%	<100%
Baker–Mountain Pass 115 kV		Diverged (164%)	<100%	<100%
Victor 230/115 kV Tr. 2, 3 & 4		Diverged (126%)	<100%	<100%
Mountain Pass–Ivanpah 115 kV		Diverged (126%)	<100%	<100%
Roadway–Victor 115 kV		Base Case	113%	<100%
	Kramer–Victor 230 kV #1 or 2 (P1)	117%	<100%	<100%
Kramer–Victor 230 kV #1 & #2 (P7)	- New Kramer–Victor 230 kV #3 & 4 (Alt1) - New Lugo–Kramer 500 kV (Alt2)	N/A	127% <sup>(1)</sup>	104% <sup>(1)</sup>

(1) These overloads can be addressed by energy storage charging or a much simplified RAS

Please refer to the on-peak deliverability section above for a more complete assessment of the mitigation alternatives for the Lugo–Victor–Kramer Corridor constraint.

**Kramer–Sandlot–Coolwater 230 kV Constraints**

Wind and solar resources in the Sandlot-Coolwater area are subject to curtailment in the base and sensitivity portfolios due to loading limitations on the Kramer–Sandlot–Coolwater 230 kV lines under contingency conditions as shown in Table F.12-20. Table F.12-21 provides summary of the constraints including mitigation alternatives considered. The constraints can be mitigated by RAS or dispatching in-development battery storage in charging mode.

Table F.12-20: Kramer–Sandlot–Coolwater 230 kV off-peak deliverability constraints

Overloaded Facility	Contingency	Loading (%)	
		Base	Sensitivity
Coolwater–Kramer 230 kV	Sandlot–Kramer 230 kV (P1)	109%	109%
Sandlot–Kramer 230 kV	Coolwater–Kramer 230 kV (P1)	106%	106%

Table F.12-21: Kramer–Sandlot–Coolwater 230 kV off-peak deliverability constraint summary

Affected renewable transmission zones		Sandlot-Coolwater area	
		Base	Sensitivity
Generic portfolio MW behind the constraint (Installed capacity)		0	0
Energy storage portfolio MW behind the constraint (Installed capacity)		0	
Renewable curtailment without mitigation (MW) (Installed capacity)		62 MW	63 MW
Mitigation Options:	Portfolio ES (in charging mode) (MW) <sup>31</sup>	Not needed	
	RAS	Planned NOL CRAS	
	Additional battery storage (MW)	Not needed	
	Transmission upgrades	Not needed	
Recommended Mitigation		Planned NOL CRAS or energy storage charging	

<sup>31</sup> The Portfolio energy storage (in charging mode) amount is the amount needed to mitigate the constraint after baseline battery storage is fully utilized.

**Calcite–Pisgah–Lugo 230 kV Corridor Constraints**

Wind and solar resources in the Calcite–Pisgah area are subject to curtailment in the base and sensitivity portfolios due to loading limitations on the Calcite–Pisgah–Lugo 230 kV Corridor under contingency conditions as shown in Table F.12-22. Table F.12-23 provides summary of the constraints including mitigation alternatives considered. The constraints can be mitigated by dispatching generic portfolio battery storage in charging mode.

Table F.12-22: Calcite–Pisgah–Lugo 230 kV corridor off-peak deliverability constraints

Overloaded Facility	Contingency	Loading (%)	
		Base	Sensitivity
Calcite–Lugo 230 kV	Calcite–Pisgah 230 kV (P1)	109%	115%
	Pisgah–Lugo 230 kV (P1)	<100%	116%
	Pisgah–Eldorado 230 kV 1 or 2 (P1)	<100%	111%
Calcite–Pisgah 230 kV	Calcite–Lugo 230 kV (P1)	106%	117%

Table F.12-23: Calcite–Pisgah–Lugo 230 kV corridor off-peak deliverability constraint summary

Affected renewable transmission zones		Calcite–Pisgah area	
		Base	Sensitivity
Generic portfolio MW behind the constraint (Installed capacity)		650 MW	1220
Energy storage portfolio MW behind the constraint (Installed capacity)		250 MW	440
Renewable curtailment without mitigation (MW) (Installed capacity)		28 MW	85 MW
Mitigation Options:	Portfolio ES (in charging mode) (MW) <sup>32</sup>	28 MW	85 MW
	RAS	Not needed	
	Additional battery storage (MW)	Note needed	
	Transmission upgrades	Not needed	
Recommended Mitigation		Generic portfolio battery storage charging	

<sup>32</sup> The Portfolio energy storage (in charging mode) amount is the amount needed to mitigate the constraint after baseline battery storage is fully utilized.



### F.12.3 Conclusion and recommendation

To address the thermal loading constraints on Lugo 500/230 kV Transformer, Lugo–Victor 230 kV 1, 2, 3 & 4 and Kramer–Victor 1 and 2 230 kV and the voltage stability and thermal loading constraint associated with the Kramer–Victor 230 kV category P7 contingency identified in the base and sensitivity portfolios, the ISO recommends the approval of Lugo–Victor–Kramer 230 kV Upgrade project. In addition to the policy benefits, which is the basis for recommending the project, the project also has significant reliability benefits and production cost savings that offset some of the project cost. The scope of the project is as follows.

- Rebuild/build Kramer–Victor 115 kV lines to 230 kV and loop the old segment of Kramer–Victor 115 kV into Roadway. This part of the project is expected to be in service in 2032;
- Add 3rd Lugo 500/230 kV Transformer. This part of the project is expected to be in service in December 2027; and
- Reconductor Lugo–Victor 230 kV No. 1, 2, 3 & 4 lines. This part of the project is expected to be in service in December 2027.

The estimated project cost is \$482 million.

The Lugo–Calcite–Pisgah 230 kV base portfolio constraints can be addressed by RAS and charging storage resources. The sensitivity portfolio constraints will be addressed in future planning cycles.

### F.13SCE Metro Area

The total capacity of resources, by resource type, selected with Full Capacity Deliverability Status (FCDS) as well as those selected as Energy Only (EO) in the SCE Metro interconnection area, are listed in Table F.13-1. The portfolios in the interconnection area are comprised of battery storage resources. All portfolio resources are modeled in policy-driven assessments except in the on-peak deliverability assessment in which only FCDS resources are modeled.

Table F.13-1: SCE Metro Interconnection Area – Base and Sensitivity Portfolios by Resource Types (FCDS, EO and Total)

Resource Type	Base Portfolio			Sensitivity Portfolio		
	FCDS	EO	Total	FCDS	EO	Total
Solar	-	-	-	-	-	-
Wind – In State	-	-	-	-	-	-
Wind – Out-of-State (Existing TX)	-	-	-	-	-	-
Wind – Out-of-State (New TX)	-	-	-	-	-	-
Wind – Offshore	-	-	-	-	-	-
Li Battery	1,161	-	1,161	1,605	-	1,605
Geothermal	-	-	-	-	-	-
Long Duration Energy Storage (LDES)	-	-	-	-	-	-
Biomass/Biogas	-	-	-	-	-	-
Distributed Solar	-	-	-	-	-	-
<b>Total</b>	<b>1,161</b>	<b>-</b>	<b>1,161</b>	<b>1,605</b>	<b>-</b>	<b>1,605</b>

Table F.13-2 shows adjustments to the base portfolio made in the SCE Metro Interconnection Area made by CPUC staff to account for allocated TPD and additional in-development resources identified.

Table F.13-2: SCE Metro Interconnection Area – Adjustments to the base portfolio to account for adjustments to in-development resources and TPD allocations

	FCDS (MW)	EO (MW)	Total (MW)
Solar	-	-	-
Wind – In State	-	-	-
Wind – Out-of-State (Existing TX)	-	-	-
Wind – Out-of-State (New TX)	-	-	-
Wind - Offshore	-	-	-
Li Battery	62	-	62
Geothermal	-	-	-
Long Duration Energy Storage (LDES)	-	-	-
Biomass/Biogass	-	-	-
Distributed Solar	-	-	-
<b>Total</b>	<b>62</b>	<b>0</b>	<b>62</b>

The resources as identified in the CPUC busbar mapping for the SCE Metro interconnection area are illustrated on the single-line diagram in Figure F.13-1.

Figure F.13-1: SCE Metro Interconnection Area – Mapped<sup>33</sup> Base Portfolio

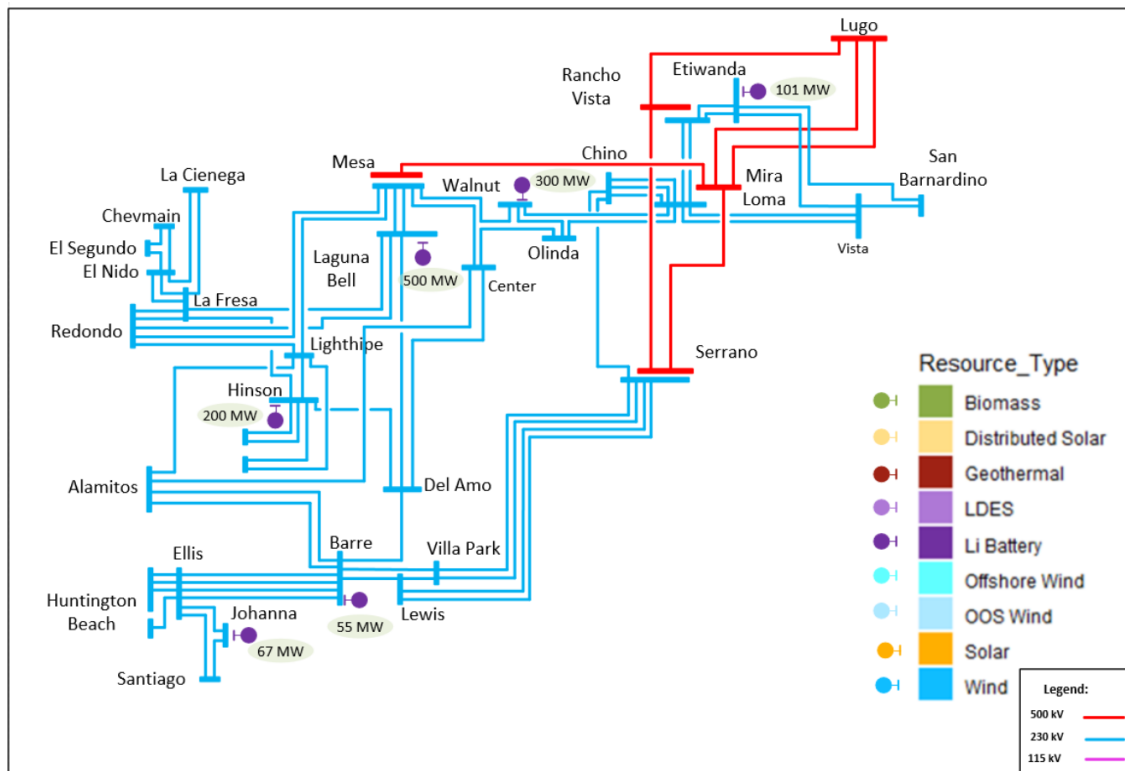

<sup>33</sup> Mapped base portfolio includes the adjustments to the base portfolio made by CPUC staff in the SCE Metro Interconnection Area to account for allocated TPD and additional in-development resources identified.

### F.13.1 On-peak results

The SCE Metro area on-peak deliverability assessment identified the following deliverability constraints that in aggregate limit delivery of resources located throughout most of southern California.

#### Mesa–Mira Loma 500 kV UG Segment Constraint

The Mesa–Mira Loma 500 kV UG segment deliverability constraint affects deliverability of capacity resources in a large part of southern California including Eastern, North of Lugo, East of Pisgah, GLW/VEA, SDG&E and IID areas due to thermal overloading of the underground segment of the Mesa–Mira Loma 500 kV line as shown in Table F.13-3. The constraint is identified in both the base and sensitivity portfolio under HSN conditions as shown in the table. 388 MW of capacity resources in the base portfolio and 3,451 MW in the sensitivity portfolio including 322 MW of MIC expansion requests will be undeliverable without mitigation, as shown in Table F.13-4.

Table F.13-3: Mesa–Mira Loma 500 kV UG segment deliverability constraint

Overloaded Facility	Contingency	Loading (%) HSN	
		Base	Sensitivity
Mesa–Mira Loma 500 kV line UG segment	Base Case	101%	111%

Table F.13-4: Mesa–Mira Loma 500 kV UG segment constraint summary

Affected transmission zones		Eastern, NOL, EOP including GLW/VEA, SDG&E and IID areas	
		Base	Sensitivity
Generic portfolio MW behind the constraint (installed FCDS capacity)		8,917 MW	21,160 MW
Generic battery storage portfolio MW behind the constraint (installed FCDS capacity)		3,932 MW	9,192 MW
Deliverable generic portfolio MW w/o mitigation (Installed FCDS capacity)		8,851 MW	18,031 MW
Total undeliverable baseline and portfolio MW (Installed FCDS capacity)		388 MW*	3,451 MW*
Mitigation Options	RAS	Not applicable	Not applicable
	Re-locate portfolio battery storage (MW)	Not applicable	Not applicable
	Transmission upgrade including cost	Add a third set of cables to the UG segment of Mesa–Mira Loma 500 kV line (\$35 Million).	
Recommended Mitigation		Add a third set of cables to the UG segment of Mesa–Mira Loma 500 kV line (\$35 Million, ISD - Q4 2026) (also recommended in the SCE Eastern Interconnection Area results).	

\* Undeliverable MW includes 322 MW of MIC requests modeled at Harry Allen 500 kV, Mead 230 kV, Victorville 500 kV, and Silver Peak 57.5 kV

Mitigation alternatives considered to address the Mesa–Mira Loma 500 kV UG segment constraint include RAS, removing generic portfolio battery storage, and transmission upgrades. RAS is not a valid alternative because the overload occurs under normal conditions. Removing generic portfolio battery storage is also not considered a viable solution because it will limit the ability to map battery storage in the large geographic area that is affected by the constraint. Based on the above considerations transmission upgrade is found to be the only viable mitigation solution.

Increasing the normal and emergency rating of the Chino Hill area underground segment of the Mesa-Mira Loma 500 kV line by adding a third set of cables addresses the constraint. The cost of the upgrade is \$35 million and will result in a 124% increase in the normal and 152% in the emergency rating of the line, which is more than sufficient to address the constraint. The addition the 500 kV underground cables is recommended for approval as a cost effective solution to address the base portfolio constraint.

### South of Mesa Corridor and Serrano–Barre Corridor Constraints

While the South of Mesa Corridor and the Serrano–Barre Corridor Constraints affect deliverability of resources in different parts of southern California they are presented together because the same mitigation alternatives are considered due of the nature of the constraints. The constraints involve the two main 500 kV substations and outgoing 230 kV lines that serve the coastal Metro area.

The South of Mesa Corridor constraint affects the deliverability of capacity resources in parts of the Northern area including Northern LA Basin, Tehachapi and Big Creek-Ventura areas due to thermal overloading of the Mesa–Lighthipe and Mesa–Laguna Bell 230 kV lines and the Mesa 500/230 kV transformer as shown in Table F.13-5. The constraint is identified in the sensitivity portfolio under HSN and/or SSN conditions as shown in the table. Up to 2,991 MW of capacity resources including 1807 MW of generic portfolio battery storage will be undeliverable without mitigation under the SSN condition, as shown in Table F.13-6.

Table F.13-5: South of Mesa corridor deliverability constraints

Overloaded Facility	Contingency	Loading (%) (HSN/SSN)	
		Base	Sensitivity
Mesa–Lighthipe 230 kV	Mesa–Redondo & Mesa–Laguna Bell #1 (P7)	<100%	111%/109%
	Mesa–Redondo & La Fresa–Laguna Bell 230 kV (P7)	<100%	106%/107%
Mesa–Laguna Bell #2	Mesa–Redondo & Mesa–Laguna Bell #1 (P7)	<100%	99%/108%
Mesa 500/230 kV transformers 3 & 4	Mesa 500/230 kV transformers 3 or 4 (P1)	<100%	96%/103%

Table F.13-6: South of Mesa corridor constraint summary

Affected transmission zones		Northern LA Basin, Parts of Tehachapi and Big Creek-Ventura	
		Base	Sensitivity (SSN)
Generic portfolio MW behind the constraint (installed FCDS capacity)		N/A	1,934 MW
Generic battery storage portfolio MW behind the constraint (installed FCDS capacity)		N/A	1,807 MW
Deliverable generic portfolio MW w/o mitigation (Installed FCDS capacity)		N/A	0 MW
Total undeliverable baseline and portfolio MW (Installed FCDS capacity)		0 MW	2,991 MW
Mitigation Options	RAS	Not needed	Not applicable
	Re-locate portfolio battery storage (MW)	Not needed	Not applicable
	Transmission upgrade including cost	Not needed	<ol style="list-style-type: none"> <li>1. Serrano-Mesa–Del Amo 500 kV Development (\$1,200 million)</li> <li>2. Mesa–Del Amo–Serano 500 kV Development (\$1,125 million)</li> <li>3. HVDC alternatives involving a 2500 MW converter station at Del Amo identified to address constraints in the SDG&amp;E and Eastern area (\$7.0B-7.6B)</li> </ol>
Recommended Mitigation		Not needed	See the Conclusions and Recommendations for the SCE Metro and Eastern and SDG&E Area Mitigation Plan

The Serrano–Barre Corridor constraint affects deliverability of capacity resources in parts of SCE Eastern, SDG&E and IID areas due to thermal overloading of the Serrano 500/230 kV transformer and the 230 kV transmission lines between Serrano and Barre substations that serve the coastal Metro area as shown in Table F.13-7. The constraint is identified in the sensitivity portfolio under HSN and/or SSN conditions as shown in the table. Up to 1,638 MW of capacity resources including 680 MW of generic portfolio battery storage will be undeliverable without mitigation under the HSN condition, as shown in Table F.13-8.

Table F.13-7: Serrano–Barre corridor deliverability constraint

Overloaded Facility	Contingency	Loading (%) HSN/SSN	
		Base	Sensitivity
Barre–Lewis 230 kV	Barre–Villa Park 230 kV (P1)	<100%	109%/101%
	San Onofre–Santiago 230 kV NO. 1 & 2 (P7)	<100%	107%/93%
Barre–Villa Park 230 kV	Barre–Lewis 230 kV (P1)	<100%	107%/99%
Serrano–Villa Park 230 kV No. 1	Serrano–Villa Park 230 kV No. 2 (P1)	<100%	102%/100%
Serrano 500/230 kV banks	Serrano 500/230 kV transformer (P1)	<100%	104%/99%

Table F.13-8: Serrano–Barre corridor constraint summary

Affected transmission zones		SCE Eastern, SDG&E and IID areas	
		Base	Sensitivity (HSN)
Generic portfolio MW behind the constraint (installed FCDS capacity)		N/A	6,350 MW
Generic battery storage portfolio MW behind the constraint (installed FCDS capacity)		N/A	3,109 MW
Deliverable generic portfolio MW w/o mitigation (Installed FCDS capacity)		N/A	4,712 MW
Total undeliverable baseline and portfolio MW (Installed FCDS capacity)		0 MW	1,638 MW
Mitigation Options	RAS	Not needed	Not applicable
	Re-locate portfolio battery storage (MW)	Not needed	Not applicable
	Transmission upgrade including cost	Not needed	Same 500 kV AC or DC development alternatives as the South of Mesa corridor constraint
Recommended Mitigation		Not needed	See the Conclusions and Recommendations for the SCE Metro and Eastern and SDG&E Area Mitigation Plan

Mitigation alternatives considered to address the South of Mesa corridor and Serrano–Barre Corridor deliverability constraints include RAS, removing generic portfolio battery storage, and transmission upgrades. RAS is not a viable alternative because the amount of generation tripping needed would exceed the applicable limit and require a large number of geographically dispersed resources with small contribution factors (DFAX) to participate. Removing generic

portfolio battery storage is also not considered a viable solution because it is not sufficient to address the Serrano–Barre Corridor constraint and it will limit the ability to map battery storage in the large geographic area covered by either constraint. Based on the above considerations transmission upgrade is found to be needed. 500 kV development closer to the coastal load center like Del Amo is considered the appropriate long-term development based on the following factors:

- The constraints involve the two main 500 kV substations and multiple outgoing 230 kV lines that serve the major coastal Metro area load center;
- MWD is proposing to install a pipeline in SCE’s ROW/easement along the Del Amo, Center corridor as part of their Pure Water Southern California Project. This phase of the project is scheduled for completion in 2032 and is currently in the environmental planning and review stage.<sup>34</sup> SCE believes this creates a good opportunity to install a double circuit 500 kV line at the same time MWD’s facilities are being installed;
- The potential for long term load growth in the area due to the traditional drivers of load growth as well as emerging drivers such as transportation electrification, fuel substitution, etc.; and
- Potential retirement of local gas fired generation in the area in the long term and the resulting increase in reliance of the area on deliverable remote resources.

Accordingly, the three 500 kV ac development alternatives described below were identified to mitigate the South of Mesa Corridor and Serrano–Barre Corridor constraints.

#### Metro Alternative 1: Serrano-Mesa–Del Amo 500 kV development

Figure F.13-2 shows the Serrano-Mesa–Del Amo 500 kV alternative. This alternative has a total cost of \$1,200 million and consists of the following developments:

- A new Mesa-Serrano 500 kV created by extending one of the existing box-looped segments of the Mesa–Mira Loma 500 kV line to Serrano;
- Build 500 kV facilities at Del Amo Substation complete with three 500/230 banks; construct two 500 kV lines from Mesa to Del Amo Substation; and
- Loop the Alamitos–Barre No. 1 and No. 2 230 kV lines into Del Amo Substation.

#### Metro Alternative 2: Mesa–Del Amo–Serrano 500 kV development

Figure F.13-3 shows the Mesa–Del Amo–Serrano 500 kV alternative. This alternative has a total cost of \$1,125 million and consists of the following developments:

- A new Mesa-Serrano 500 kV line created by extending one of the existing box-looped segments of the Mesa–Mira Loma 500 kV line to Serrano;

<sup>34</sup> <https://www.mwdh2o.com/building-local-supplies/pure-water-southern-california-notice-of-preparation/>

- Build 500 kV facilities at Del Amo Substation complete with three 500/230 banks; construct two 500 kV lines to loop the new Mesa–Serrano 500 kV line into Del Amo Substation; and
- Loop Alamitos–Barre No. 1 and No. 2 230 kV lines into Del Amo Substation.

Metro Alternative 3: Imperial Valley–North of SONGS–Del Amo 500 kV HVDC development

Figure F.13-4 shows the Metro area portion of the Imperial Valley–North of SONGS–Del Amo 500 kV HVDC development alternative. While this alternative helps in addressing the constraints identified in the Metro area, it is developed primarily to address constraints identified in the SDG&E and SCE Eastern areas. Because of its broader scope, it cannot be directly compared with the Metro area 500 kV AC alternatives described above whose scope is limited to mitigating constraints that are identified in the Metro area. As such, the preferred Metro area 500 kV AC alternative is evaluated in conjunction with the 500 kV AC alternatives that are identified for SDG&E and Eastern areas as an alternative to this three terminal HVDC development. Please see the SDG&E and SCE Eastern area sections for a detailed description and evaluation of this HVDC alternative as well as the 500 kV AC alternatives that are considered in conjunction with the preferred Metro area 500 kV AC alternative.

Figure F.13-2: Serrano-Mesa–Del Amo 500 kV development (Metro Alternative 1)

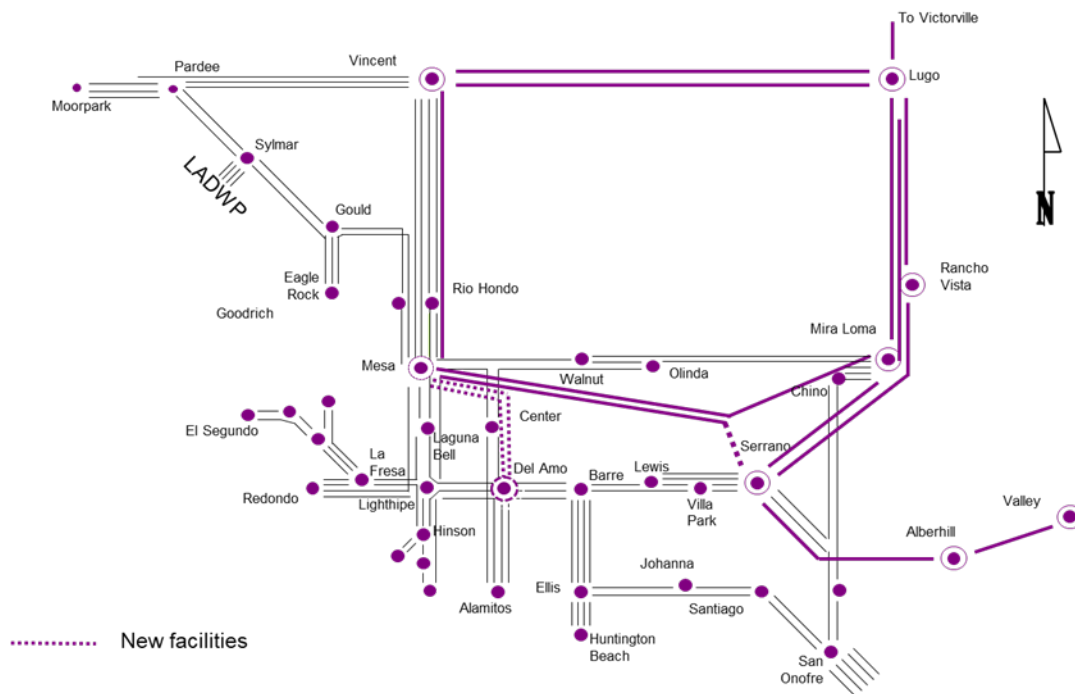



Figure F.13-3: Mesa–Del Amo–Serrano 500 kV development (Metro Alternative 2)

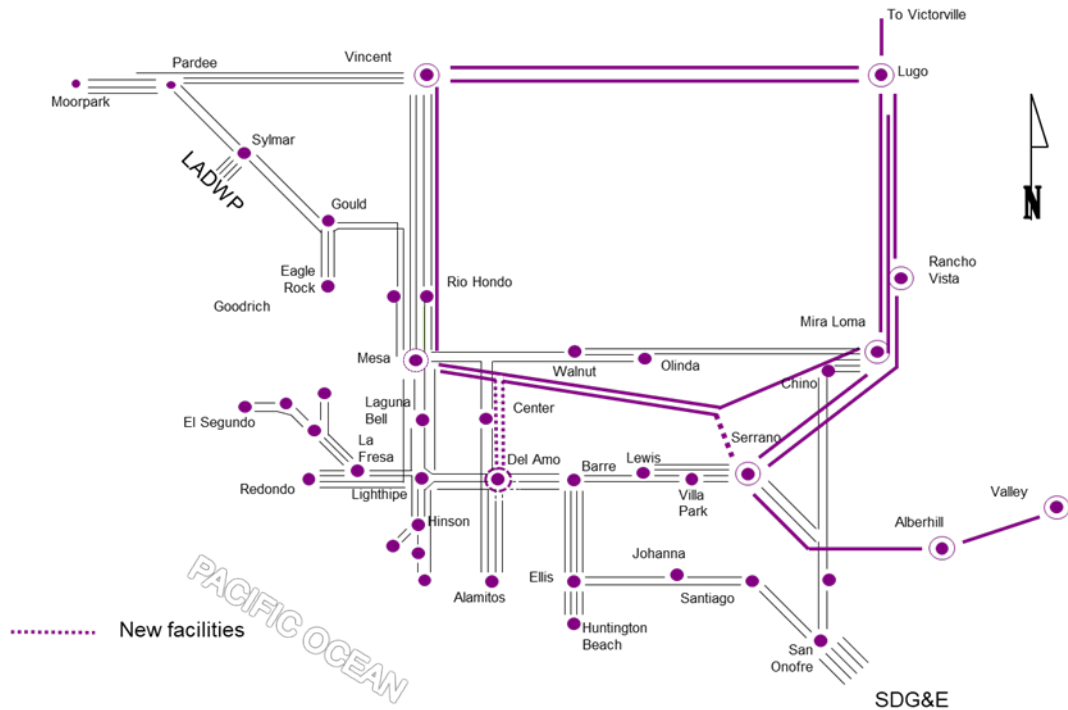

Figure F.13-4: Imperial Valley–North of SONGS–Del Amo HVDC development (Metro Alternative 3)

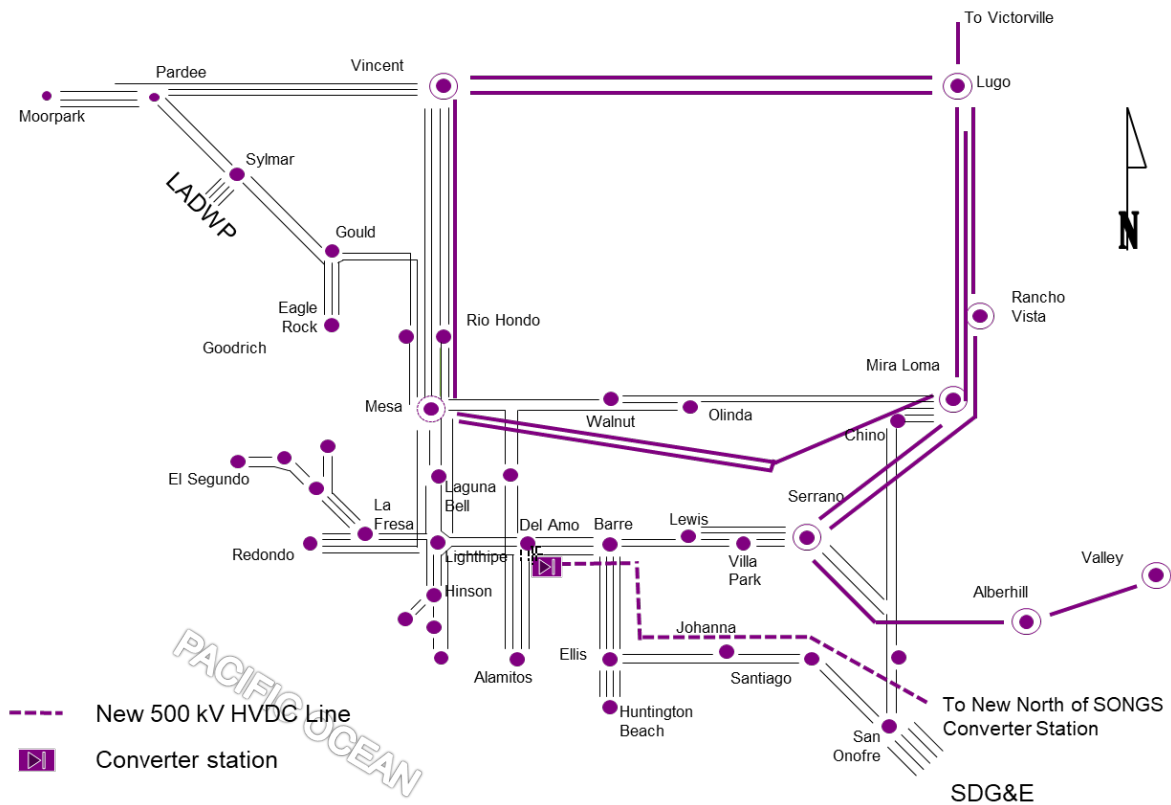

Table F.13-9 provides a comparison of the performance of the Metro area alternatives in addressing the South of Mesa Corridor and Serrano–Barre Corridor constraints. The analysis is performed for the sensitivity portfolio.

Table F.13-9: Comparison of alternatives for South of Mesa Corridor and Serrano–Barre Corridor constraints

Overloaded Facility	Contingency	Sensitivity Loading (%) (HSN/SSN)		
		Metro Alt 1	Metro Alt 2	Metro Alt 3 (HVDC)
Mesa–Lighthipe 230 kV	Mesa–Redondo & Mesa–Laguna Bell #1 (P7)	<90%	<90%	93%
	Mesa–Redondo & La Fresa–Laguna Bell 230 kV (P7)	<90%	<90%	<94%
Mesa–Laguna Bell #2	Mesa–Redondo & Mesa–Laguna Bell #1 (P7)	<90%	<90%	<90%
Mesa 500/230 kV transformers 3 & 4	Mesa 500/230 kV transformers 3 or 4 (P1)	<90%	<90%	91%
Barre–Lewis 230 kV	Barre–Villa Park 230 kV (P1)	<90%	<90%	<90%
	San Onofre–Santiago 230 kV N0. 1 & 2 (P7)	<90%	<90%	<90%
Barre–Villa Park 230 kV	Barre–Lewis 230 kV (P1)	<90%	<90%	<90%
Serrano–Villa Park 230 kV No. 1	Serrano–Villa Park 230 kV No. 2 (P1)	<90%	<90%	90%
Serrano 500/230 kV banks	Serrano 500/230 kV transformer (P1)	<90%	<90%	90%

The results indicate that all three Metro area alternatives address the South of Mesa Corridor and Serrano–Barre Corridor constraints. The Mesa–Del Amo–Serrano 500 kV development or Metro Alternative 2 has the following benefits compared to Alternative 1:

- It has a lower cost;
- It links the new Del Amo 500 kV substation to two 500 kV substations, i.e. Serrano and Mesa, which makes it a more robust source for the area; and
- The ISO understands the entire length of the double circuit 500 kV line out of Del Amo is along SCE’s ROW that MWD is proposing to use to install its planned pipeline. SCE expects this would facilitate construction of the line if it is done at the same time as MWD’s facilities are being installed.

As noted above, this preferred alternative will be evaluated in conjunction with the 500 kV AC alternatives identified for SDG&E/SCE Eastern area as an alternative to the HVDC development alternatives identified for the area.

**Mira Loma–Chino No. 3 230 kV Line Constraint**

The Mira Loma–Chino No. 3 230 kV line deliverability constraint affects deliverability of capacity resources in parts of the SCE Eastern area due to thermal overloading of the Mira Loma–Chino No. 3 230 kV line under category P7 conditions as shown in Table F.13-10. The constraint is identified in the sensitivity portfolio under HSN conditions as shown in the table. 1,792 MW of capacity resources including 201 MW of generic battery storage will be undeliverable without mitigation, as shown in Table F.13-11.

Table F.13-10: Mira Loma–Chino No. 3 230 kV line deliverability constraint

Overloaded Facility	Contingency	Loading (%) HSN	
		Base	Sensitivity
Chino–Mira Loma No. 3 230 kV line	Chino–Mira Loma No. 1 & 2 230 kV lines (P7)	<100	115%

Table F.13-11: Mira Loma–Chino No. 3 230 kV line constraint summary

Affected transmission zones		Parts of the SCE Eastern area	
		Base	Sensitivity
Generic portfolio MW behind the constraint (installed FCDS capacity)		N/A	204 MW
Generic battery storage portfolio MW behind the constraint (installed FCDS capacity)		N/A	201 MW
Deliverable generic portfolio MW w/o mitigation (Installed FCDS capacity)		N/A	0
Total undeliverable baseline and portfolio MW (Installed FCDS capacity)		0 MW	1,792*
Mitigation Options	RAS	Not needed	Not applicable
	Re-locate portfolio battery storage (MW)	Not needed	Not applicable
	Transmission upgrade including cost	Not needed	Increase Rating of Chino – Mira Loma No. 3 230 kV line (\$15 Million)
Recommended Mitigation		Not needed	Increasing the rating of Chino – Mira Loma No. 3 230 kV line will be considered in the next planning cycle

Mitigation alternatives considered to address the Mira Loma–Chino No. 3 230 kV line constraint include RAS, removing generic portfolio battery storage, and transmission upgrades. RAS is not a valid alternative because the amount of generation tripping needed would exceed the 1400 MW limit for a P7 contingency. Removing generic portfolio battery storage is also not

considered a viable solution because it is not sufficient to address the constraint. Based on this considerations transmission upgrade is found to be the only viable mitigation solution.

The transmission upgrade that is considered to address the constraint is to increase the rating of the Chino–Mira Loma No. 3 230 kV line by upgrading terminal equipment to match the rating of the line conductors. The cost of the upgrade is \$15 million and will result in a 130% and 172% increase in the normal and emergency ratings of the line, respectively, which is more than sufficient to address the constraint. Since the constraint is identified in the sensitivity portfolio and the mitigation does not require a long time to construct, the transmission upgrade is not recommended for approval in the current planning cycle and will be re-evaluated in the next planning cycle.

### Hinson–La Fresa 230 kV 230 kV Line Constraint

The Hinson–La Fresa 230 kV line deliverability constraint affects deliverability of capacity resources in the Hinson–Long Beach area due to thermal overloading of the Hinson–La Fresa 230 kV line as shown in Table F.13-12. The constraint is identified in the sensitivity portfolio under SSN conditions as shown in the table. 945 MW of capacity resources including 248 MW of generic portfolio battery storage will be undeliverable without mitigation, as shown in Table F.13-13. Curtailing all of the resources with at least 5% impact on the constraint did not fully address the overload suggesting the constraint is also a local capacity issue.

Table F.13-12: Hinson–La Fresa 230 kV line deliverability constraint

Overloaded Facility	Contingency	Loading (%) SSN	
		Base	Sensitivity
Hinson–La Fresa 230 kV line	Mesa–Redondo & La Fresa–Laguna Bell 230 kV (P7)	<100	109%

Table F.13-13: Hinson–La Fresa 230 kV line constraint summary

Affected transmission zones		Hinson–Long Beach area	
		Base	Sensitivity
Generic portfolio MW behind the constraint (installed FCDS capacity)		N/A	246 MW
Generic battery storage portfolio MW behind the constraint (installed FCDS capacity)		N/A	246 MW
Deliverable generic portfolio MW w/o mitigation (Installed FCDS capacity)		N/A	0
Total undeliverable baseline and portfolio MW (Installed FCDS capacity)		0 MW	945 MW <sup>+</sup>
Mitigation Options	RAS	Not needed	Not applicable
	Re-locate portfolio battery storage (MW)	Not needed	Not applicable
	Transmission upgrade including cost	Not needed	Increase rating of Hinson–La Fresa 230 kV Line (\$ 10 Million)
Recommended Mitigation		Not needed	The transmission upgrade will be considered in the next planning cycle

Mitigation alternatives considered to address the Hinson–La Fresa 230 kV line constraint include RAS, removing generic portfolio battery storage, and transmission upgrades. RAS is not a valid alternative because curtailing all of the resources with at least 5% contribution did not address the overload. Removing generic portfolio battery storage is also not considered a viable solution because it is not sufficient to address the constraint. Based on these considerations transmission upgrade is found to be the only viable mitigation solution.

The transmission upgrade that is identified to address the constraint is to increase the rating of the Hinson-La Fresa 230 kV line by upgrading terminal equipment to match the rating of the line conductors. The cost of the upgrade is \$10 million and will result in a 124% and 151% increase in the normal and emergency ratings of the line, respectively, which is more than sufficient to address the constraint. Since the constraint is identified in the sensitivity portfolio and the mitigation does not require a long time to construct, the transmission upgrade is not recommended for approval in the current planning cycle and will be re-evaluated in the next planning cycle.

## F.13.2 Off-peak results

### South of Mesa Corridor constraint

Wind and solar resources in parts of the Northern area are subject to curtailment in the sensitivity portfolio due to loading limitations on Mesa–Lighthipe 230 kV line under contingency conditions as shown in Table F.13-14. Table F.13-15 provides summary of the constraint including mitigation alternatives considered. The constraints can be mitigated by dispatching baseline and generic portfolio battery storage in charging mode or by the transmission upgrades considered to address the impact of the constraint under on-peak conditions. A new RAS is not considered a valid option due to the small contribution factor (DFAX) of the generators behind the constraint that are scattered over a large geographic area.

Table F.13-14: South of Mesa corridor 230 kV off-peak deliverability constraint

Overloaded Facility	Contingency	Loading (%)	
		Base	Sensitivity
Mesa–Lighthipe 230 kV	Mesa–Redondo & Mesa–Laguna Bell #1 (P7)	<100%	101%

Table F.13-15: South of Mesa corridor 230 kV off-peak deliverability constraint summary

Affected renewable transmission zones		Parts of the Northern area	
		Base	Sensitivity
Generic portfolio MW behind the constraint (Installed capacity)		N/A	2,782 MW
Energy storage portfolio MW behind the constraint (Installed capacity)		N/A	1,227 MW
Renewable curtailment without mitigation (MW) (Installed capacity)		0 MW	532 MW
Mitigation Options:	Portfolio ES (in charging mode) (MW) <sup>35</sup>	Not needed	334 MW
	RAS	Not needed	Not applicable due to low effectiveness
	Additional battery storage (MW)	Not needed	Not needed
	Transmission upgrades	Not needed	Same as on-peak
Recommended Mitigation		Not needed	Baseline and generic energy storage charging

<sup>35</sup> The Portfolio energy storage (in charging mode) amount is the amount needed to mitigate the constraint after baseline battery storage is fully utilized.

### F.13.3 Summary of Metro area results

The SCE Metro area deliverability assessment identified one base portfolio and multiple sensitivity on-peak deliverability constraints that require transmission upgrades. Together, the constraints limit deliverability of capacity resources in most parts of southern California. Table F.13-16 provides a summary of the constraints identified along with the preferred transmission upgrade, the portfolio for which transmission upgrade is needed and whether the transmission upgrade is recommended for approval in the current planning cycle. The Metro area off-peak deliverability assessment did not identify constraints that require transmission upgrades.

Table F.13-16: Summary of SCE Metro area results

Constraint	Preferred transmission upgrade and cost	Portfolio for which Mitigation is Needed		Recommended for approval in the current planning cycle
		Base	Sens	
Mesa–Mira Loma 500 kV UG cable	Mesa–Mira Loma 500 kV UG cable upgrade (\$35M)	✓	✓	Yes
South of Mesa corridor	Mesa–Del Amo–Serrano 500 kV Development (\$1,125 million)		✓	See the Conclusions and Recommendations for the SCE Metro and Eastern and SDG&E Area Mitigation Plan Section 3.9
Serrano–Barre corridor			✓	
Mira Loma–Chino No. 3 230 kV line	Chino – Mira Loma No. 3 230 kV line increase (\$15 Million)		✓	No
Hinson–La Fresa 230 kV line	Hinson–La Fresa 230 kV line rating increase (\$10 Million)		✓	No

### F.14SCE Eastern

The total capacity of resources, by resource type, selected with Full Capacity Deliverability Status (FCDS) as well as those selected as Energy Only (EO) in the SCE Eastern interconnection area are listed in Table F.14-1. The portfolios are comprised of solar, wind (in-state and out-of-state), battery storage and biomass/biogass resources. All portfolio resources are modeled in policy-driven assessments except in the on-peak deliverability assessment in which only FCDS resources are modeled.

Table F.14-1: SCE Eastern Interconnection Area – Base and Sensitivity Portfolios by Resource Types (FCDS, EO and Total)

Resource Type	Base Portfolio			Sensitivity Portfolio		
	FCDS	EO	Total	FCDS	EO	Total
Solar	1,262	1,716	2,978	2,067	5,250	7,517
Wind – In State	106	-	106	116	-	116
Wind – Out-of-State (Existing TX)	124	-	124	124	-	124
Wind – Out-of-State (New TX)	438	-	438	2,328	-	2,328
Wind – Offshore	-	-	-	-	-	-
Li Battery	2,098	-	2,098	5,350	-	5,350
Geothermal	-	-	-	-	-	-
Long Duration Energy Storage (LDES)	-	-	-	700	-	700
Biomass/Biogass	3	-	3	3	-	3
Distributed Solar	-	-	-	-	-	-
<b>Total</b>	<b>4,031</b>	<b>1,716</b>	<b>5,747</b>	<b>10,687</b>	<b>5,250</b>	<b>15,937</b>

Table F.14-2 shows adjustments to the base portfolio made in the SCE Eastern Interconnection Area made by CPUC staff to account for allocated TPD and additional in-development resources identified.

Table F.14-2: SCE Eastern Interconnection Area – Adjustments to the base portfolio to account for adjustments to in-development resources and TPD allocations

	FCDS (MW)	EO (MW)	Total (MW)
Solar	518	-2	516
Wind – In State	9	0	9
Wind – Out-of-State (Existing TX)	-	-	-
Wind – Out-of-State (New TX)	-	-	-
Wind - Offshore	-	-	-
Li Battery	3101	0	3101
Geothermal	-	-	-
Long Duration Energy Storage (LDES)	-	-	-
Biomass/Biogass	-	-	-
Distributed Solar	-	-	-
<b>Total</b>	<b>3628</b>	<b>-2</b>	<b>3626</b>

The resources as identified in the CPUC busbar mapping for the SCE Eastern interconnection area are illustrated on the single-line diagram in Figure F.14-1.



Figure F.14-1: SCE Eastern Interconnection Area – Mapped<sup>36</sup> Base Portfolio

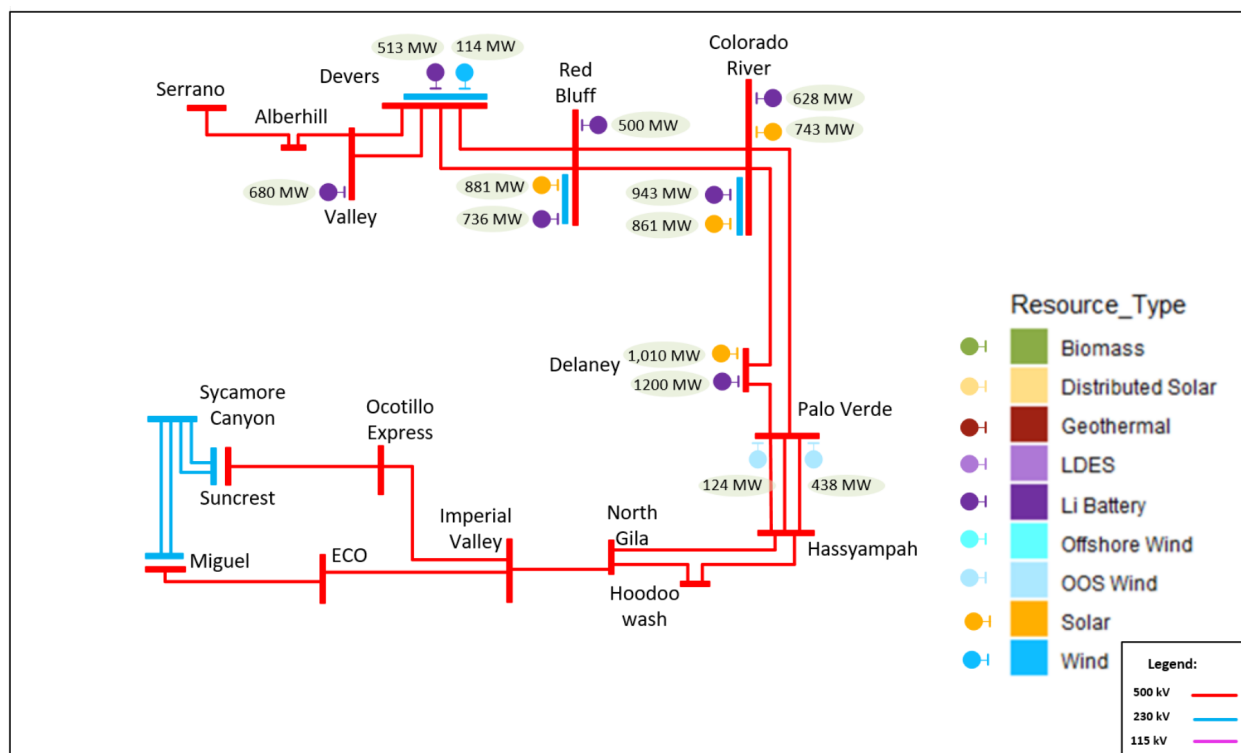

### F.14.1 On-peak results

#### Eastern Area: Devers-Red Bluff 500 kV constraint

The deliverability of FC resources in the SCE Eastern, East of Pisgah, and SDG&E areas is limited by thermal overloading of the Devers-Red Bluff 500 kV lines under P0, P1 and P7 conditions as shown in Table F.14-3. The constraint was identified in the base and sensitivity portfolios. Overloads were seen in both the HSN and SSN scenarios, with the higher loadings being in the HSN scenario. Table F.14-4 shows the amount of portfolio generation that would be deliverable without any transmission upgrades.

<sup>36</sup> Mapped base portfolio includes the adjustments to the base portfolio made by CPUC staff in the SCE Eastern Interconnection Area to account for allocated TPD and additional in-development resources identified.

Table F.14-3: Devers – Red Bluff 500 kV Deliverability Constraint

Overloaded Facility	Contingency	Highest Loading (%) (HSN)	
		Base	Sensitivity
Devers – Red Bluff 500 kV No.1	Devers – Red Bluff 500 kV No. 2	145	172
	N.Gila – Imperial Valley 500 kV No.1	<100	105
	Base Case	<100	104
	Devers – Mirage 230 kV No.1 AND Devers – Mirage 230 kV No.2	<100	101
	Eldorado – Lugo 500 kV No.1	<100	101
Devers – Red Bluff 500 kV No.2	Devers – Red Bluff 500 kV No.1	142	169
	Base Case	<100	104

Table F.14-4: Devers – Red Bluff 500 kV Deliverability Constraint Summary

Affected transmission zones		SCE Eastern (east of Red Bluff), East of Pisgah, and SDG&E areas	
		Base	Sensitivity
Generic Portfolio MW behind the constraint (installed FCDS capacity)		5821	14739
Generic Battery storage portfolio MW behind the constraint (installed FCDS capacity)		1404	5002
Deliverable Generic Portfolio MW w/o mitigation (Installed FCDS capacity)		0	0
Total undeliverable baseline and portfolio MW (Installed FCDS capacity)		7956	15033
Mitigation Options	RAS	West of Colorado River CRAS RAS alone not sufficient RAS is marginally sufficient with SCE Eastern area line upgrades	West of Colorado River CRAS with Eastern area line upgrades is not sufficient
	Re-locate generic portfolio battery storage (MW)	Not sufficient	
	Transmission upgrade	Upgrade Devers-Red Bluff No.1 Upgrade Devers-Red Bluff No.2	
		-	Alternative A1:

			<ul style="list-style-type: none"> <li>• New Imperial Valley-Inland-Serrano 500 kV transmission line</li> </ul> <p>Alternative B1:</p> <ul style="list-style-type: none"> <li>• Multi-terminal HVDC VSC Imperial Valley – Inland – Del Amo</li> </ul> <p>Alternative C:</p> <ul style="list-style-type: none"> <li>• New Devers-Red Bluff 500 kV transmission line</li> <li>• New Devers-Mira Loma 500 kV transmission line</li> </ul>
<p>Recommended Mitigation</p>		<p>Upgrade Devers-Red Bluff No. 1 and Devers-Red Bluff No. 2 as a first step to increase deliverability in the SCE Eastern area</p> <p>See the Conclusions and Recommendations for the SCE Metro and Eastern and SDG&amp;E Area Mitigation Plan</p>	

The Devers-Red Bluff 500 kV constraint can only be partially mitigated by using the West of Colorado River CRAS to trip generation. The CRAS alone is not sufficient for both the base and sensitivity portfolios since the amount of generation tripping needed exceeds the 1150 MW limit for a P1 contingency. Relocating generic portfolio battery storage is also not considered to be a viable solution to sufficiently address the constraint. To fully mitigate the overloads, transmission upgrades are required.

Increasing the rating of the Devers-Red Bluff No.1 and Devers-Red Bluff No.2 500 kV lines is the first step of transmission upgrades considered to address this constraint. This would maximize the use of existing transmission infrastructure as much as possible. The rating of the No. 1 line is to be increased from 2598 / 2858 MVA (normal/emergency) to 3291 / 3880 MVA (normal/emergency). And the rating of the No. 2 line is to be increased from 2598 / 2910 MVA (normal/emergency) to 3291 / 3880 MVA (normal/emergency). The cost for upgrading the No. 1 and No.2 lines is \$120 million and \$20 million, respectively. With these proposed line upgrades, the West of Colorado River CRAS becomes marginally sufficient to mitigate the constraint for the base portfolio.

See the Conclusions and Recommendations for the SCE Metro and Eastern and SDG&E Area Mitigation Plan section below for details regarding the mitigation alternative packages studied in conjunction with the SCE Metro and SDG&E area assessments.

**Eastern Area: Serrano-Alberhill-Valley 500 kV constraint**

The deliverability of FC resources in the SCE Eastern and SDG&E areas is limited by thermal overloading of lines and transformers as shown in Table F.14-5. The constraint was identified in the base and sensitivity portfolios, with the highest loadings being observed under the HSN scenario. Table F.14-6 shows the amount of portfolio generation that would be deliverable without any transmission upgrades.

Table F.14-5: Serrano – Alberhill – Valley 500 kV Deliverability Constraint

Overloaded Facility	Contingency	Highest Loading (%) (HSN)	
		Base	Sensitivity
Devers – Valley 500 kV No.1	Devers – Valley 500 kV No.2	114	136
Serrano–Alberhill–Valley 500 kV No.1	Base Case	110	127
San Bernardino – Vista 230 kV No.1	Devers – Vista 230 kV No.1 AND Devers – Vista 230 kV No.2	111	127
	San Bernardino – Etiwanda 230 kV No.1	101	110
	San Bernardino – Etiwanda 230 kV No.1 AND Vista – Etiwanda 230 kV No.1	<100	104
	Serrano–Alberhill–Valley 500 kV No.1	<100	106
Vista – Etiwanda 230 kV No.1	Wildlife – Vista 230 kV No.1 AND Mira Loma – Vista 230 kV No.2	110	118
	Mira Loma – Wildlife 230 kV No.1 AND Mira Loma – Vista 230 kV No.2	102	108
	Serrano–Alberhill–Valley 500 kV No.1	103	106
San Bernardino – Etiwanda 230 kV No.1	San Bernardino – Vista 230 kV No.1	104	113
	Serrano–Alberhill–Valley 500 kV No.1	<100	103
Mira Loma – Mesa 500 kV No.1	Base Case	102	111
Devers 500/230 kV Transformer No.1	Serrano–Alberhill–Valley 500 kV No.1	102	117
Devers 500/230 kV Transformer No.2	Serrano–Alberhill–Valley 500 kV No.1	<100	109

Table F.14-6: Serrano – Alberhill – Valley 500 kV Deliverability Constraint Summary

Affected transmission zones		SCE Eastern and SDG&E	
		Base	Sensitivity
Generic Portfolio MW behind the constraint (installed FCDS capacity)		2514	8233
Generic Battery storage portfolio MW behind the constraint (installed FCDS capacity)		769	2961
Deliverable Generic Portfolio MW w/o mitigation (Installed FCDS capacity)		0	2952
Total undeliverable baseline and portfolio MW (Installed FCDS capacity)		2732	5281
Mitigation Options	RAS	West of Colorado River CRAS No RAS available to address Base Case and 230 kV line overloads	
	Re-locate generic portfolio battery storage (MW)	Not sufficient	
	Transmission upgrade	Upgrade Devers-Valley No.1 Upgrade Serrano-Alberhill No.1 and Alberhill-Valley No.1 Upgrade San Bernardino-Etiwanda No.1 Upgrade San Bernardino-Vista No.1 Upgrade Vista-Etiwanda No.1 Mira Loma-Mesa 500kV Underground Cable Addition	
Recommended Mitigation		Upgrade the lines identified in the “Transmission upgrade” section above Mira Loma-Mesa 500kV Underground Cable Addition  See the Conclusions and Recommendations for the SCE Metro and Eastern and SDG&E Area Mitigation Plan	

Tripping generation via the West of Colorado River CRAS can be used to help mitigate some of the overloads. However, use of the CRAS is not sufficient for the Devers-Valley No.1 overload in both the base and sensitivity portfolios since the amount of generation tripping needed exceeds the 1150 MW limit for a P1 contingency. Furthermore, there is no RAS available to address the base case and 230 kV line overloads. As such, RAS alone is not a valid solution for the Serrano-Alberhill-Valley constraint. Relocating generic portfolio battery storage is also not considered to be a viable solution to sufficiently address the constraint. To fully mitigate all of these overloads for the base and sensitivity portfolios, transmission upgrades are required.

The transmission upgrades considered to address the constraint is to increase the rating of the following lines:

- Devers-Valley No.1 500 kV line from 2598 / 2858 MVA (normal/emergency) to 3421 / 3880 MVA (normal/emergency) - \$45 million;
- Serrano-Alberhill No.1 500 kV line from 2598 / 4157 MVA (normal/emergency) to 3421 / 4157 MVA (normal/emergency) & Alberhill-Valley No.1 500 kV line from 2598 / 4157 MVA (normal/emergency) to 3421 / 4616 MVA (normal/emergency) - \$60 million;
- San Bernardino-Etiwanda No.1 230 kV line from 988 / 1040 MVA (normal/emergency) to 1287 / 1737 MVA (normal/emergency) - \$65 million;
- San Bernardino-Vista No.1 230 kV line from 988 / 1331 MVA (normal/emergency) to 1287 / 1737 MVA (normal/emergency) - \$18 million; and
- Vista-Etiwanda No.1 230 kV line from 797 / 876 MVA (normal/emergency) to 988 / 1331 MVA (normal/emergency) - \$13 million.

In addition, a third underground cable is considered to be installed on the most limiting section of the existing Mira Loma-Mesa 500 kV circuit, increasing the rating of the section from 1992 / 3204 MVA (normal/emergency) to 3421 / 4616 MVA (normal/emergency). The cost of this upgrade is \$35 million.

**Eastern Area: Colorado River-Red Bluff 500 kV constraint**

The deliverability of FC resources in the SCE Eastern, East of Pisgah, and SDG&E areas is limited by thermal overloading of the Colorado River-Red Bluff 500 kV No. 1 line as shown in Table F.14-7. The constraint was identified in the base and sensitivity portfolios, with the highest loadings being observed under the HSN scenario. Table F.14-8 shows the amount of portfolio generation that would be deliverable without any transmission upgrades.

Table F.14-7: Colorado River – Red Bluff 500 kV Deliverability Constraint

Overloaded Facility	Contingency	Highest Loading (%) (HSN)	
		Base	Sensitivity
Colorado River – Red Bluff 500 kV No.1	Colorado River – Red Bluff 500 kV No.2	108	109

Table F.14-8: Colorado River – Red Bluff 500 kV Deliverability Constraint Summary

Affected transmission zones		SCE Eastern (east of Colorado River), East of Pisgah, and SDG&E areas	
		Base	Sensitivity
Generic Portfolio MW behind the constraint (installed FCDS capacity)		5821	13221
Generic Battery storage portfolio MW behind the constraint (installed FCDS capacity)		1404	4523
Deliverable Generic Portfolio MW w/o mitigation (Installed FCDS capacity)		4847	11450
Total undeliverable baseline and portfolio MW (Installed FCDS capacity)		1150	1972
Mitigation Options	RAS	West of Colorado River CRAS RAS is marginally sufficient	West of Colorado River CRAS is not sufficient
	Re-locate generic portfolio battery storage (MW)	Not sufficient	
	Transmission upgrade	Upgrade Colorado River-Red Bluff No.1	
Recommended Mitigation		Upgrade Colorado River-Red Bluff No.1  See the Conclusions and Recommendations for the SCE Metro and Eastern and SDG&E Area Mitigation Plan	

Using the West of Colorado River CRAS to trip generation is marginally sufficient to mitigate the overload in the base portfolio. The amount of generation tripping needed for the base portfolio is close to the 1150 MW limit for a P1 contingency. Relocating generic portfolio battery storage is also not considered to be a viable solution to sufficiently address the constraint. To fully mitigate the overload in the base and sensitivity portfolios, transmission upgrades are required.

The transmission upgrade considered to address the constraint is to increase the rating of the Colorado River-Red Bluff No.1 500 kV line from 2338 / 2858 MVA (normal/emergency) to 3421 / 3880 MVA (normal/emergency). The cost of this upgrade is \$50 million. Given that this upgrade is cost effective and that the CRAS is only marginally sufficient for the base portfolio and is inadequate for the sensitivity portfolio, this line upgrade is recommended as a solution for both the base and sensitivity portfolios.

**Eastern Area: Colorado River 500/230 kV constraint**

The deliverability of FC resources interconnecting at the Colorado River 230 kV bus is limited by thermal overloading of the 500/230 kV transformers under Category P1 conditions as shown in Table F.14-9. The constraint was identified in the base and sensitivity portfolios, with the highest loadings being observed under the HSN scenario. The constraint can be mitigated by the planned West of Colorado River CRAS.

Table F.14-9: Colorado River 500/230 kV Deliverability Constraint

Overloaded Facility	Contingency	Highest Loading (%) (HSN)	
		Base	Sensitivity
Colorado River 500/230 kV Transformer No.1	Colorado River 500/230 kV Transformer No.2	124	124
Colorado River 500/230 kV Transformer No.2	Colorado River 500/230 kV Transformer No.1	124	124

Table F.14-10: Colorado River 500/230 kV Deliverability Constraint Summary

Affected transmission zones		Colorado River	
		Base	Sensitivity
Generic Portfolio MW behind the constraint (installed FCDS capacity)		0	371
Generic Battery storage portfolio MW behind the constraint (installed FCDS capacity)		0	207
Deliverable Generic Portfolio MW w/o mitigation (Installed FCDS capacity)		n/a	0
Total undeliverable baseline and portfolio MW (Installed FCDS capacity)		323	465
Mitigation Options	RAS	West of Colorado River CRAS	
	Re-locate generic portfolio battery storage (MW)	Not needed	
	Transmission upgrade	Not needed	
Recommended Mitigation		West of Colorado River CRAS	



### Summary of SCE Eastern area mitigation plans

Table F.14-11, Table F.14-12, Table F.14-13, and Table F.14-14 highlights the transmission upgrades directly related to addressing the the Devers-Red Bluff, Serrano-Alberhill-Valley, and Colorado River-Red Bluff 500 kV constraints, respectively. However, due to the interdependent nature of the SCE Eastern area, mitigation alternatives were evaluated in conjunction with other SCE Eastern area deliverability constraints as well as the SCE Metro and SDG&E area assessments. Overall benefits to the SCE Eastern, SCE Metro, and SDG&E areas are considered in the preferred alternative selection process.

The full transmission upgrade scope and estimated costs of the mitigation alternative packages considered are as follows.

Table F.14-11: Eastern Area 500 kV and 230 kV Line Upgrades

Upgrade	Upgrade details	Cost (\$M)	Base	Sensitivity
SCE Eastern area 500 kV and 230 kV line upgrades	Upgrade Colorado River-Red Bluff No.1 from 2338 / 2858 MVA (normal/emergency) to 3421 / 3880 MVA (normal/emergency)	\$50	X	X
	Upgrade Devers-Red Bluff No.1 from 2598 / 2858 MVA (normal/emergency) to 3291 / 3880 MVA (normal/emergency)	\$120	X	X
	Upgrade Devers-Red Bluff No.2 from 2598 / 2910 MVA (normal/emergency) to 3291 / 3880 MVA (normal/emergency)	\$20	X	X
	Upgrade Devers-Valley No.1 from 2598 / 2858 MVA (normal/emergency) to 3421 / 3880 MVA (normal/emergency)	\$45	X	X
	Upgrade Serrano-Alberhill No.1 from 2598 / 4157 MVA (normal/emergency) to 3421 / 4157 MVA (normal/emergency) & Alberhill-Valley No.1 from 2598 / 4157 MVA (normal/emergency) to 3421 / 4616 MVA (normal/emergency)	\$60	X	X
	Upgrade San Bernardino-Etiwanda No.1 from 988 / 1040 MVA (normal/emergency) to 1287 / 1737 MVA (normal/emergency)	\$65	X	X
	Upgrade San Bernardino-Vista No.1 from 988 / 1331 MVA (normal/emergency) to 1287 / 1737 MVA (normal/emergency)	\$18	X	X
	Upgrade Vista-Etiwanda No.1 from 797 / 876 MVA (normal/emergency) to 988 / 1331 MVA (normal/emergency)	\$13	X	X
	Mira Loma-Mesa 500kV Underground Cable Addition: Add 3rd set of 5000 kcmil to underground section to increase the rating of the most limiting section of the existing Mira Loma-Mesa 500 kV circuit, the rating will be upgraded from 1992 / 3204 MVA (normal/emergency) to 3421 / 4616 MVA (normal/emergency)	\$35	X	X

Table F.14-12: Eastern Area Alternative A1 Scope and Cost Estimate

Upgrade	Upgrade details	Cost (\$M)	Base	Sensitivity
SCE Eastern area 500 kV and 230 kV line upgrades	See the Eastern Area 500 kV and 230 kV Line Upgrades table	\$426	X	X
SDG&E area upgrades*	TL Imperial Valley – Inland 500 kV (~110-130 miles) with 50% series compensation	\$3,991	X <sup>37</sup>	X
	TL Inland – Serrano 500 kV (~55-65 miles) with 50% series compensation			
	Two 500/230 kV AA transformers at Inland			
	TL23030 Talega – Escondido 230 kV reconductor to a minimum rating of 912 MVA and loop-in at Inland			
	New TL Talega – Escondido 230 kV using the vacant side of the existing tower supporting TL23030 with a minimum rating of 912 MVA and loop-in at Inland			
	TL North Gila – Imperial Valley 2 and loop-in at Highline (IID) with a 500/230 kV transformer			
SCE Metro area upgrades**	Mesa–Del Amo–Serrano 500 kV development in SCE Metro area	\$1,125		X

\* Refer to SDG&E area assessment in for further details regarding scope and costs

\*\* Refer to SCE Metro area assessment described above for details regarding scope and costs

Table F.14-13: Eastern Area Alternative B1 Scope and Cost Estimate

Upgrade	Upgrade details	Cost (\$M)	Base	Sensitivity
SCE Eastern area 500 kV and 230 kV line upgrades	See the Eastern Area 500 kV and 230 kV Line Upgrades table	\$426	X	X
SDG&E area upgrades*	Multi-terminal HVDC VSC Imperial Valley – Inland – Del Amo	\$7,187	X	X
	Imperial Valley Converter Station 2200 MW			
	Inland Converter Station 1000 MW in normal condition and 2000 MW in emergency condition			
	Del Amo Converter Station 1200 MW in normal condition and 2000 MW in emergency condition			
	TL23030 Talega – Escondido 230 kV reconductor to a minimum rating of 912 MVA and loop-in at Inland			
	New TL Talega – Escondido 230 kV using the vacant side of the existing tower supporting TL23030 with a minimum rating of 912 MVA and loop-in at Inland			
	TL North Gila – Imperial Valley 2 and loop-in at Highline (IID) with a 500/230 kV transformer			

\* Refer to SDG&E area assessment for further details regarding scope and costs

<sup>37</sup> RAS as mitigation is potentially marginally sufficient in near-term; however not for longer-term and for sensitivity portfolio.

Table F.14-14: Eastern Area Alternative C Scope and Cost Estimate

Upgrade	Upgrade details	Cost (\$M)	Base	Sensitivity
SCE Eastern area 500 kV and 230 kV line upgrades	See the Eastern Area 500 kV and 230 kV Line Upgrades table	\$426	X	X
Devers-Red Bluff 500 kV line	New Devers-Red Bluff 500 kV No. 3 transmission line (~77 miles) with 46% series compensation	\$920	X	X
Devers-Mira Loma 500 kV line	New Devers-Mira Loma 500 kV transmission line (~78 miles) with 15% series compensation	\$1,528	X	X

Upgrading the ratings of various 500 kV and 230 kV lines, as well as the Mira Loma-Mesa underground cable addition, is common to all three alternatives. These upgrades are a cost effective first step option to increase deliverability in the SCE Eastern area.

### F.14.2 Off-peak results

#### Eastern Area: Colorado River 500/230 kV off-peak deliverability constraint

Wind and solar resources interconnecting at the Colorado River 230 kV bus are subject to curtailment in the base and sensitivity portfolios due to loading limitations on the transformers as shown in Table F.14-15. Pre-contingency curtailment can be avoided by dispatching portfolio energy storage in charging mode and/or utilizing the planned West of Colorado River CRAS.

Table F.14-15: Colorado River 500/230 kV off-peak deliverability constraint

Overloaded Facility	Contingency	Loading (%)	
		Base	Sensitivity
Colorado River 500/230 kV Transformer No.1	Colorado River 500/230 kV Transformer No.2	114	160
Colorado River 500/230 kV Transformer No.2	Colorado River 500/230 kV Transformer No.1	114	160

Table F.14-16: Colorado River 500/230 kV off-peak deliverability constraint summary

Affected renewable transmission zones		Colorado River	
		Base	Sensitivity
Renewable portfolio MW behind the constraint (installed capacity)		0	986
Energy storage (ES) portfolio MW behind the constraint (installed capacity)		0	207
Renewable curtailment without mitigation (MW) (installed capacity)		254	1038
Mitigation Options:	Portfolio ES (in charging mode) (MW) <sup>38</sup>	Not applicable	799
	RAS	West of Colorado River CRAS	
	Additional battery storage (MW)	Not needed	
	Transmission upgrades	Not needed	
Recommended Mitigation		West of Colorado River CRAS and/or batteries in charging mode	

### Eastern Area: Red Bluff 500/230 kV off-peak deliverability constraint

Wind and solar resources interconnecting at the Red Bluff 230 kV bus are subject to curtailment in the base and sensitivity portfolios due to loading limitations on the transformers as shown in Table F.14-17. Pre-contingency curtailment can be avoided by utilizing the planned West of Colorado River CRAS.

Table F.14-17: Red Bluff 500/230 kV off-peak deliverability constraint

Overloaded Facility	Contingency	Loading (%)	
		Base	Sensitivity
Red Bluff 500/230 kV Transformer No.1	Red Bluff 500/230 kV Transformer No.2	107	154
Red Bluff 500/230 kV Transformer No.2	Red Bluff 500/230 kV Transformer No.1	107	154

<sup>38</sup> The Portfolio energy storage (in charging mode) amount is the amount needed to mitigate the constraint after baseline battery storage is fully utilized.

Table F.14-18: Red Bluff 500/230 kV off-peak deliverability constraint summary

Affected renewable transmission zones		Red Bluff	
		Base	Sensitivity
Renewable portfolio MW behind the constraint (installed capacity)		0	894
Energy storage (ES) portfolio MW behind the constraint (installed capacity)		0	78
Renewable curtailment without mitigation (MW) (installed capacity)		140	940
Mitigation Options:	Portfolio ES (in charging mode) (MW) <sup>39</sup>	Not applicable	Not sufficient
	RAS	West of Colorado River CRAS	
	Additional battery storage (MW)	Not needed	
	Transmission upgrades	Not needed	
Recommended Mitigation		West of Colorado River CRAS	

**Eastern Area: Devers-Red Bluff 500 kV off-peak deliverability constraint**

Wind and solar resources in the SCE Eastern, East of Pisgah, and SDG&E areas are subject to curtailment in the base and sensitivity portfolios due to loading limitations on the Devers-Red Bluff 500 kV lines as shown in Table F.14-19. These constraints were also identified in the on-peak deliverability assessment, and the loadings are higher in the on-peak study. The mitigation proposed for the on-peak Devers-Red Bluff constraint will also mitigate the off-peak constraints.

Table F.14-19: Devers-Red Bluff 500 kV off-peak deliverability constraint

Overloaded Facility	Contingency	Loading (%)	
		Base	Sensitivity
Devers – Red Bluff 500 kV No.1	Devers – Red Bluff 500 kV No.2	106	148
Devers – Red Bluff 500 kV No.2	Devers – Red Bluff 500 kV No.1	103	144

<sup>39</sup> The Portfolio energy storage (in charging mode) amount is the amount needed to mitigate the constraint after baseline battery storage is fully utilized.

Table F.14-20: Devers-Red Bluff 500 kV off-peak deliverability constraint summary

Affected renewable transmission zones		SCE Eastern (east of Red Bluff), East of Pisgah, and SDG&E areas
		<b>Base</b>
		<b>Sensitivity</b>
Renewable portfolio MW behind the constraint (installed capacity)		8290
Energy storage (ES) portfolio MW behind the constraint (installed capacity)		1404
Renewable curtailment without mitigation (MW) (installed capacity)		1187
Mitigation Options:	Portfolio ES (in charging mode) (MW) <sup>40</sup>	Not applicable
	RAS	West of Colorado River CRAS
	Additional battery storage (MW)	Not applicable
	Transmission upgrades	See SCE Eastern area on-peak deliverability constraint mitigation
Recommended Mitigation		See SCE Eastern area on-peak deliverability constraint mitigation

**Eastern Area: Serrano-Alberhill-Valley 500 kV off-peak deliverability constraint**

Wind and solar resources in the SCE Eastern and SDG&E areas are subject to curtailment in the sensitivity portfolio due to loading limitations on lines and transformers as shown in Table F.14-21. These constraints were also identified in the on-peak deliverability assessment, and the loadings are higher in the on-peak study. The mitigation proposed for the on-peak Serrano-Alberhill-Valley constraint will also mitigate the off-peak constraints.

Table F.14-21: Serrano-Alberhill-Valley 500 kV off-peak deliverability constraint

Overloaded Facility	Contingency	Loading (%)	
		Base	Sensitivity
Devers – Valley 500 kV No.1	Devers – Valley 500 kV No.2	<100	105
Devers 500/230 kV Transformer No.1	Serrano–Alberhill–Valley 500 kV No.1	<100	102

<sup>40</sup> The Portfolio energy storage (in charging mode) amount is the amount needed to mitigate the constraint after baseline battery storage is fully utilized.

Table F.14-22: Serrano-Alberhill-Valley 500 kV off-peak deliverability constraint summary

Affected renewable transmission zones		SCE Eastern and SDG&E	
		Base	Sensitivity
Renewable portfolio MW behind the constraint (installed capacity)		Not applicable	13686
Energy storage (ES) portfolio MW behind the constraint (installed capacity)		Not applicable	3661
Renewable curtailment without mitigation (MW) (installed capacity)		Not applicable	1541
Mitigation Options:	Portfolio ES (in charging mode) (MW) <sup>41</sup>	Not applicable	Not applicable
	RAS		West of Colorado River CRAS
	Additional battery storage (MW)		Not applicable
	Transmission upgrades		See SCE Eastern area on-peak deliverability constraint mitigation
Recommended Mitigation			See SCE Eastern area on-peak deliverability constraint mitigation

## F.15SDG&E area

### F.15.1 On-peak results

Table F.15-1 includes the total capacity of resources, by resource type, selected with Full Capacity Deliverability Status (FCDS) as well as those selected as Energy Only (EO) in the SDG&E interconnection area. The portfolios in the interconnection area are comprised of solar, wind (instate), battery storage, geothermal, and long duration energy storage resources. All portfolio resources are modeled in policy-driven assessments except in the on-peak deliverability assessment in which only FCDS resources are modeled.

<sup>41</sup> The Portfolio energy storage (in charging mode) amount is the amount needed to mitigate the constraint after baseline battery storage is fully utilized.

Table F.15-1: SDG&E Interconnection Area – Base and Sensitivity Portfolios by Resource Types (FCDS, EO and Total)

Resource Type	Base Portfolio			Sensitivity Portfolio		
	FCDS	EO	Total	FCDS	EO	Total
Solar	300	871	1,171	484	1,390	1,874
Wind – In State	600	-	600	600	-	600
Wind – Out-of-State (Existing TX)	-	-	-	-	-	-
Wind – Out-of-State (New TX)	-	-	-	-	-	-
Wind – Offshore	-	-	-	-	-	-
Li Battery	1,418	-	1,418	2,527	-	2,527
Geothermal	600	-	600	900	-	900
Long Duration Energy Storage (LDES)	500	-	500	500	-	500
Biomass/Biogass	-	-	-	-	-	-
Distributed Solar	-	-	-	-	-	-
<b>Total</b>	<b>3,418</b>	<b>871</b>	<b>4,289</b>	<b>5,011</b>	<b>1,390</b>	<b>6,401</b>

Table F.15-2 shows adjustments to the base portfolio made in the SDG&E Interconnection Area made by CPUC staff to account for allocated TPD and additional in-development resources identified.

Table F.15-2: SDG&E Interconnection Area – Adjustments to the base portfolio to account for adjustments to in-development resources and TPD allocations

	FCDS (MW)	EO (MW)	Total (MW)
Solar	183	-	183
Wind – In State	-	-	-
Wind – Out-of-State (Existing TX)	-	-	-
Wind – Out-of-State (New TX)	-	-	-
Wind - Offshore	-	-	-
Li Battery	684	-	684
Geothermal	-	-	-
Long Duration Energy Storage (LDES)	-	-	-
Biomass/Biogass	-	-	-
Distributed Solar	-	-	-
<b>Total</b>	<b>867</b>	<b>-</b>	<b>867</b>





Table F.15-3: East of Miguel constraint

Overloaded Facility	Contingency	Highest Loading (%) (HSN)	
		Base	Sensitivity
Suncrest-Sycamore 230 kV #2	Suncrest-Sycamore 230 kV #1	109	133
Suncrest-Sycamore 230 kV #1	Suncrest-Sycamore 230 kV #2	109	133
Suncrest-Sycamore 230 kV #2	ECO-Miguel 500 kV	107	134
Suncrest-Sycamore 230 kV #1	ECO-Miguel 500 kV	107	134
Suncrest-Sycamore 230 kV #1	IV-ECO 500 kV	< 100	122
Suncrest-Sycamore 230 kV #1	Otay Mesa-Miguel-Sycamore and Otay Mesa-Miguel-Bay Boulevard 230 kV	< 100	101
Suncrest-Sycamore 230 kV #2	IV-ECO 500 kV	< 100	122
Suncrest-Sycamore 230 kV #2	Otay Mesa-Miguel-Sycamore and Otay Mesa-Miguel-Bay Boulevard 230 kV	< 100	101
Miguel Bank 80 500/230 kV #1	Miguel Bank 81 500/230 kV #2	116	144
Miguel Bank 80 500/230 kV #1	Miguel Bank 81 500/230 kV #2	115	143
Miguel Bank 81 500/230 kV #2	Miguel Bank 80 500/230 kV #1	114	141
Miguel Bank 81 500/230 kV #2	OCO-Suncrest 500 kV	< 100	106
Miguel Bank 81 500/230 kV #2	IV-ECO 500 kV	< 100	104
Miguel Bank 81 500/230 kV #2	Sycamore-Suncrest 230 kV #1 and #2	< 100	106
Miguel Bank 80 500/230 kV #1	OCO-Suncrest 500 kV	< 100	110
Miguel Bank 80 500/230 kV #1	IV-ECO 500 kV	< 100	108
Miguel Bank 80 500/230 kV #1	Sycamore-Suncrest 230 kV #1 and #2	< 100	110
Miguel Bank 80 500/230 kV #1	OCO-Suncrest 500 kV	< 100	111
Miguel Bank 80 500/230 kV #1	IV-ECO 500 kV	< 100	109
Miguel Bank 80 500/230 kV #1	Sycamore-Suncrest 230 kV #1 and #2	< 100	111
ECO-Miguel 500 kV	OCO-Suncrest 500 kV	< 100	114
ECO-Miguel 500 kV	IV-ECO 500 kV	< 100	113
ECO-Miguel 500 kV	Otay Mesa-Miguel-Sycamore and Otay Mesa-Miguel-Bay Boulevard 230 kV	< 100	104
ECO-Miguel 500 kV	Sycamore-Suncrest 230 kV #1 and #2	< 100	114



**Bay Boulevard-Silvergate constraint**

The deliverability of portfolio resources in the Bay Boulevard-Silvergate area is limited by thermal overloading of the Bay Boulevard-Silvergate 230 kV line as shown in Table F.15-5. These overloads were identified for the base and sensitivity portfolios. The constraints were seen in both the HSN and SSN scenarios, with the higher loadings being in the HSN scenario. Table F.15-6 shows the amount of portfolio generation that would be deliverable without any transmission upgrades.

The constraint can be partially mitigated by using the 2-hour emergency rating of the Bay Boulevard-Silvergate 230 kV line. To fully mitigate the overloads, transmission upgrades are required. Table F.9.1-5 shows the various mitigation options that were considered.

Table F.15-5: Bay Boulevard-Silvergate constraints

Overloaded Facility	Contingency	Highest Loading (%) (HSN)	
		Base	Sensitivity
Bay Boulevard-Silvergate 230 kV	Miguel-Mission 230 kV #1 and #2	130	146
Bay Boulevard-Silvergate 230 kV	Sycamore-Penasquitos 230 kV	127	142
Bay Boulevard-Silvergate 230 kV	Sycamore-Suncrest 230 kV #1 and #2	118	134
Bay Boulevard-Silvergate 230 kV	OCO-Suncrest 500 kV	118	134
Bay Boulevard-Silvergate 230 kV	IV-ECO 500 kV	116	133
Bay Boulevard-Silvergate 230 kV	Miguel-Mission 230 kV #2	111	< 100
Bay Boulevard-Silvergate 230 kV	Base Case	< 100	107
Bay Boulevard-Silvergate 230 kV	Proctor Valley-Telegraph Canyon 138 kV and Miguel-Telegraph Canyon-Los Cochis 138 kV	< 100	123

Table F.15-6: Bay Boulevard-Silvergate deliverability constraint summary

Affected transmission zones	Baja, Imperial, San Diego	
	Base	Sensitivity
Generic Portfolio MW behind the constraint (installed FCDS capacity)	1209	1676
Generic Battery storage portfolio MW behind the constraint (installed FCDS capacity)	10	475
Deliverable Generic Portfolio MW w/o mitigation (Installed FCDS capacity)	0	0
Total undeliverable baseline and portfolio MW (Installed FCDS capacity)	2373	3408

Mitigation Options	RAS	None
	Re-locate generic portfolio battery storage (MW)	Not adequate
	Transmission upgrade	Option 1: <ul style="list-style-type: none"> <li>• 2 hour emergency rating on Silvergate-Bay Boulevard 230 kV line</li> <li>• SDGE BES Project Part 2 - Old Town/Silvergate area - rebuild TL13822 Mission-Carlton Hills for a double 230 kV for looping TL23041 OM-ML-SX into Mission (Sycamore-San Luis Rey and Miguel-Mission #3). Reconductor TL23022 (ML-MS) and TL23023 (ML-MS) and TL23001 (SLR-MS) and TL23004 (SLR-MS). Install 2 phase shifter transformers at Mission (MS-ML and SX-SLR)</li> </ul>
		Option 2: <ul style="list-style-type: none"> <li>• 2 hour emergency rating on Silvergate-Bay Boulevard 230 kV line</li> <li>• Silvergate-Bay Boulevard 230 kV 3ohm series reactor</li> <li>• Sycamore-Penasquitos 3ohm series reactor</li> </ul>
Option 3: <ul style="list-style-type: none"> <li>• 2 hour emergency rating on Silvergate-Bay Boulevard 230 kV line, new Imperial Valley-Serrano 500 kV line</li> <li>• 500 kV mitigation out of Imperial Valley (see SDG&amp;E summary section for details of considered options)</li> </ul>		
Recommended Mitigation	See the Conclusions and Recommendations for the SCE Metro and Eastern and SDG&E Area Mitigation Plan	

**Encina-San Luis Rey constraint**

The deliverability of portfolio resources in the Encina-San Luis Rey area is limited by thermal overloading of various 230 kV and 69 kV lines as shown in Table F.15-7. These overloads were identified for the base and sensitivity portfolios. The constraints were seen in both the HSN and SSN scenarios, with the higher loadings being in the HSN scenario. Table F.15-8 shows the amount of portfolio generation that would be deliverable without any transmission upgrades.

The constraint can be partially mitigated by using RAS to trip generation. To fully mitigate the overloads, transmission upgrades are required. Table F.15-8 shows the various mitigation options that were considered.

Table F.15-7: Encina-San Luis Rey constraints

Overloaded Facility	Contingency	Highest Loading (%) (HSN)	
		Base	Sensitivity
Encina Tap-San Luis Rey 230 kV	San Luis Rey-Encina 230 kV	163	151
Encina-San Luis Rey 230 kV	San Luis Rey-Encina-Palomar 230 kV	142	130
Encina-San Luis Rey 230 kV	San Luis Rey-Encina-Palomar 230 kV and Encina-Palomar 138 kV	142	130
Encina-San Luis Rey 230 kV	San Luis Rey-Encina-Palomar 230 kV and Batiquitos-Shadowridge 138 kV	142	130
Encina-San Luis Rey 230 kV	San Luis Rey-Encina-Palomar 230 kV and Palomar-Batiquitos 138 kV	142	129
Mission-San Luis Rey SC 230 kV #2	San Luis Rey-Encina 230 kV and San Luis Rey-Encina-Palomar 230 kV	129	119
Mission-San Luis Rey SC 230 kV #1	San Luis Rey-Encina 230 kV and San Luis Rey-Encina-Palomar 230 kV	129	118
Encina Tap-San Luis Rey 230 kV	San Luis Rey-Mission 230 kV #1 and #2	120	112
Encina-Encina Tap 230 kV	San Luis Rey-Encina 230 kV	120	107
Encina-San Luis Rey 230 kV	San Luis Rey-Mission 230 kV #1 and #2	110	101
Encina Tap-San Luis Rey 230 kV	Escondido-Talega 230 kV	110	103
Encina Tap-San Luis Rey 230 kV	San Luis Rey-Mission 230 kV #2	106	< 100
Encina Tap-San Luis Rey 230 kV	San Luis Rey-Mission 230 kV #1	106	< 100
Escondido-Talega Tap 230 kV	San Luis Rey-Encina 230 kV and San Luis Rey-Encina-Palomar 230 kV	105	101
Escondido-San Marcos 69 kV #1	San Luis Rey-Encina 230 kV and San Luis Rey-Encina-Palomar 230 kV	105	105

Table F.15-8: Encina-San Luis Rey deliverability constraint summary

Affected transmission zones		Baja, Imperial, San Diego
		Base
		Sensitivity
Generic Portfolio MW behind the constraint (installed FCDS capacity)		1958
Generic Battery storage portfolio MW behind the constraint (installed FCDS capacity)		510
Deliverable Generic Portfolio MW w/o mitigation (Installed FCDS capacity)		0
Total undeliverable baseline and portfolio MW (Installed FCDS capacity)		2776
Mitigation Options	RAS	CEC RAS (under construction), not sufficient
	Re-locate generic portfolio battery storage (MW)	Not adequate
	Transmission upgrade	Option 1: <ul style="list-style-type: none"> <li>30 minute emergency rating on Encina Tap-San Luis Rey 230 kV line</li> <li>SDGE BES Project Part 2 - Old Town/Silvergate area - rebuild TL13822 Mission-Carlton Hills for a double 230 kV for looping TL23041 OM-ML-SX into Mission (Sycamore-San Luis Rey and Miguel-Mission #3). Reconductor TL23022 (ML-MS) and TL23023 (ML-MS) and TL23001 (SLR-MS) and TL23004 (SLR-MS). Install 2 phase shifter transformers at Mission (MS-ML and SX-SLR)</li> </ul>
		Option 2: <ul style="list-style-type: none"> <li>30 minute emergency rating on Encina Tap-San Luis Rey 230 kV line</li> <li>new Encina-San Luis Rey 230 kV line</li> </ul>
Option 3: <ul style="list-style-type: none"> <li>30 minute emergency rating on Encina Tap-San Luis Rey 230 kV line</li> <li>500 kV mitigation out of Imperial Valley (see SDG&amp;E summary section for details of considered options)</li> </ul>		
Recommended Mitigation		See the Conclusions and Recommendations for the SCE Metro and Eastern and SDG&E Area Mitigation Plan

### Sycamore area constraint

The deliverability of portfolio resources in the Sycamore area is limited by thermal overloading of several lines in the Sycamore area as shown in Table F.15-9. These overloads were identified for the base and sensitivity portfolios. The constraints were seen in both the HSN and SSN scenarios, with the higher loadings being in the HSN scenario. Table F.15-10 shows the amount of portfolio generation that would be deliverable without any transmission upgrades.

To fully mitigate the overloads, transmission upgrades are required. Table F.15-10 shows the various mitigation options that were considered.

Table F.15-9: Sycamore area constraints

Overloaded Facility	Contingency	Highest Loading (%) (HSN)	
		Base	Sensitivity
Sycamore-Chicarita 138 kV	Penasquitos-Old Town 230 kV and Sycamore-Penasquitos 230 kV	133	154
Sycamore-Chicarita 138 kV	Sycamore-Penasquitos 230 kV	110	133
Sycamore-Chicarita 138 kV	Encina-Penasquitos 230 kV #1 and #2	106	124
Sycamore-Chicarita 138 kV	Sycamore-Chicarita 138 kV and Sycamore-Santee 138 kV	102	128
Sycamore-Chicarita 138 kV	Base Case	< 100	100
Sycamore-Chicarita 138 kV	Sycamore-Santee and Mission-Carlton Hills 138 kV	< 100	123
Sycamore-Chicarita 138 kV	Encina-Palomar 138 kV and Penasquitos-Encina-Batiquitos 138 kV	< 100	115
Sycamore-Scripps 69 kV	Sycamore-Penasquitos 230 kV	< 100	116
Sycamore-Artesian 230 kV	Sycamore-Penasquitos 230 kV	< 100	101
Sycamore-Penasquitos 230 kV	Silvergate-Bay Boulevard 230 kV and Telegraph Canyon-Grant Hill 138 kV	115	128
Sycamore-Penasquitos 230 kV	Sycamore-Artesian 230 kV	111	124
Sycamore-Penasquitos 230 kV	Silvergate-Bay Boulevard 230 kV	111	124
Sycamore-Penasquitos 230 kV	Silvergate-Mission-Old Town 230 kV and Silvergate-Old Town 230 kV	109	121
Sycamore-Penasquitos 230 kV	Artesian-Palomar 230 kV	106	< 100
Sycamore-Penasquitos 230 kV	ECO-Miguel 500 kV	105	117
Sycamore-Penasquitos 230 kV	Base Case	< 100	103
Sycamore-Penasquitos 230 kV	IV-ECO 500 kV	< 100	112



Table F.15-10: Sycamore area deliverability constraint summary

Affected transmission zones		Arizona, Baja, Imperial, San Diego	
		Base	Sensitivity
Generic Portfolio MW behind the constraint (installed FCDS capacity)		1509	2716
Generic Battery storage portfolio MW behind the constraint (installed FCDS capacity)		310	1264
Deliverable Generic Portfolio MW w/o mitigation (Installed FCDS capacity)		1030	1314
Total undeliverable baseline and portfolio MW (Installed FCDS capacity)		680	2329
Mitigation Options	RAS	None	
	Re-locate generic portfolio battery storage (MW)	Not adequate	
	Transmission upgrade	Option 1: <ul style="list-style-type: none"> <li>SDGE BES Project Part 2 - Old Town/Silvergate area - rebuild TL13822 Mission-Carlton Hills for a double 230 kV for looping TL23041 OM-ML-SX into Mission (Sycamore-San Luis Rey and Miguel-Mission #3). Reconductor TL23022 (ML-MS) and TL23023 (ML-MS) and TL23001 (SLR-MS) and TL23004 (SLR-MS). Install 2 phase shifter transformers at Mission (MS-ML and SX-SLR)</li> <li>upgrade TL13820 Sycamore-Chicarita 138 kV</li> <li>use 30 min emergency rating for Sycamore-Scripps 69 kV line</li> </ul> Option 2: <ul style="list-style-type: none"> <li>500 kV mitigation out of Imperial Valley (see SDG&amp;E summary section for details of considered options)</li> <li>upgrade Sycamore-Chicarita 138 kV</li> <li>use 30 min emergency rating for Sycamore-Scripps 69 kV line</li> <li>new 3 ohm reactor on Sycamore-Penasquitos 230 kV</li> </ul>	
Recommended Mitigation		See the Conclusions and Recommendations for the SCE Metro and Eastern and SDG&E Area Mitigation Plan	

**San Luis Rey-San Onofre constraint**

The deliverability of portfolio resources in the San Luis Rey-San Onofre area is limited by thermal overloading of the San Luis Rey-San Onofre 230 kV lines as shown in Table F.15-11.

These overloads were identified for the base and sensitivity portfolios. The constraints were seen in both the HSN and SSN scenarios, with the higher loadings being in the HSN scenario. Table F.15-12 shows the amount of portfolio generation that would be deliverable without any transmission upgrades.

To fully mitigate the overloads, transmission upgrades are required. Table F.15-12 shows the various mitigation options that were considered.

Table F.15-11: San Luis Rey-San Onofre constraints

Overloaded Facility	Contingency	Highest Loading (%) (HSN)	
		Base	Sensitivity
San Luis Rey-San Onofre 230 kV #1	San Luis Rey-San Onofre 230 kV #2 and #3	161	148
San Luis Rey-San Onofre 230 kV #1	San Luis Rey-San Onofre 230 KV #2	104	< 100
San Luis Rey-San Onofre 230 kV #1	San Luis Rey-San Onofre 230 KV #3	103	< 100
San Luis Rey-San Onofre 230 kV #2	San Luis Rey-San Onofre 230 KV #1	102	< 100

Table F.15-12: San Luis Rey-San Onofre deliverability constraint summary

Affected transmission zones		Arizona, Baja, Imperial, San Diego	
		Base	Sensitivity
Generic Portfolio MW behind the constraint (installed FCDS capacity)		2427	3625
Generic Battery storage portfolio MW behind the constraint (installed FCDS capacity)		1028	2037
Deliverable Generic Portfolio MW w/o mitigation (Installed FCDS capacity)		0	3801
Total undeliverable baseline and portfolio MW (Installed FCDS capacity)		3454	1120
Mitigation Options	RAS	CEC RAS (under construction), not sufficient	
	Re-locate generic portfolio battery storage (MW)	Not adequate	
	Transmission upgrade	Option 1: SDGE BES Project Part 3 - Proposed projects in the San Luis Rey/San Onofre area - upgrade TL23006 SLR-SO to form new SLR-SO 230 kV #4 line Option 2: 500 kV mitigation out of Imperial Valley (see SDG&E summary section for details of considered options)	
Recommended Mitigation		See the Conclusions and Recommendations for the SCE Metro and Eastern and SDG&E Area Mitigation Plan	

### Silvergate-Old Town constraint

The deliverability of portfolio resources in the Silvergate-Old Town area is limited by thermal overloading of the Silvergate-Old Town 230 kV lines as shown in Table F.15-13. These overloads were identified for the base and sensitivity portfolios. The constraints were seen in both the HSN and SSN scenarios, with the higher loadings being in the HSN scenario. Table F.15-14 shows the amount of portfolio generation that would be deliverable without any transmission upgrades.

The constraint can be partially mitigated by using the 30 minute rating of the overloaded lines and a proposed RAS to trip generation. To fully mitigate the overloads, transmission upgrades are required. Table F.15-14 shows the various mitigation options that were considered.

Table F.15-13: Silvergate-Old Town constraints

Overloaded Facility	Contingency	Highest Loading (%) (HSN)	
		Base	Sensitivity
Silvergate-Old Town Tap 230 kV	Silvergate-Old Town 230 kV	152	161
Silvergate-Old Town 230 kV	Silvergate-Mission-Old Town 230 kV	150	159
Silvergate-Old Town 230 kV	Silvergate-Mission-Old Town 230 kV and Old Town-Mission 230 kV	132	142
Silvergate-Old Town 230 kV	Miguel-Mission 230 kV #1 and #2	122	131
Silvergate-Old Town Tap 230 kV	Miguel-Mission 230 kV #1 and #2	119	128
Silvergate-Old Town 230 kV	Sycamore-Penasquitos 230 kV	118	127
Silvergate-Old Town Tap 230 kV	Sycamore-Penasquitos 230 kV	115	123
Silvergate-Old Town 230 kV	Sycamore-Suncrest 230 kV #1 and #2	108	118
Silvergate-Old Town 230 kV	OCO-Suncrest 500 kV	108	118
Silvergate-Old Town Tap 230 kV	Sycamore-Suncrest 230 kV #1 and #2	106	115
Silvergate-Old Town Tap 230 kV	OCO-Suncrest 500 kV	105	115
Silvergate-Old Town Tap 230 kV	IV-ECO 500 kV	104	113

Table F.15-14: Silvergate-Old Town deliverability constraint summary

Affected transmission zones		Baja, Imperial, San Diego
		Base
		Sensitivity
Generic Portfolio MW behind the constraint (installed FCDS capacity)		909
Generic Battery storage portfolio MW behind the constraint (installed FCDS capacity)		210
Deliverable Generic Portfolio MW w/o mitigation (Installed FCDS capacity)		0
Total undeliverable baseline and portfolio MW (Installed FCDS capacity)		1944
Mitigation Options	RAS	Proposed RAS to trip generation at Silvergate, not sufficient
	Re-locate generic portfolio battery storage (MW)	Not adequate
	Transmission upgrade	Option 1: <ul style="list-style-type: none"> <li>• Use 30 min emergency rating for Silvergate-Old Town and Silvergate-Old Town Tap 230 kV lines</li> <li>• SDGE BES Project Part 4 - Old Town 230 kV rearrangement - loop TL23028 SG-OT into Mission, tap TL23029 SG-OT on TL23013 OT-PQ</li> <li>• Mitigate overload on Old Town Tap-Penasquitos 230 kV</li> </ul>
		Option 2: <ul style="list-style-type: none"> <li>• Use 30 min emergency rating for Silvergate-Old Town and Silvergate-Old Town Tap 230 kV lines</li> <li>• 500 kV mitigation out of Imperial Valley (see SDG&amp;E summary section for details of considered options)</li> </ul>
Recommended Mitigation		See the Conclusions and Recommendations for the SCE Metro and Eastern and SDG&E Area Mitigation Plan

### Friars-Doublet Tap constraint

The deliverability of portfolio resources in the Friars-Doublet Tap area is limited by thermal overloading of various lines following the P7 outage of Penasquitos-Old Town 230 kV and Sycamore-Penasquitos 230 kV lines as shown in Table F.15-15. These overloads were identified for the base and sensitivity portfolios. The constraints were seen in both the HSN and SSN scenarios, with the higher loadings being in the HSN scenario. Table F.15-16 shows the amount of portfolio generation that would be deliverable without any transmission upgrades.

There is an existing RAS that trips generation that partially mitigates the constraints. This RAS is not a preferred long-term solution because the generation that it trips is not very effective. To fully mitigate the overloads, it is proposed to eliminate the RAS and build a transmission upgrade. Table F.15-16 shows the various mitigation options that were considered.

Table F.15-15: Friars-Doublet Tap constraints

Overloaded Facility	Contingency	Highest Loading (%) (HSN)	
		Base	Sensitivity
Friars-Doublet Tap 138 kV	Penasquitos-Old Town 230 kV and Sycamore-Penasquitos 230 kV	156	175
Doublet Tap-Penasquitos 138 kV	Penasquitos-Old Town 230 kV and Sycamore-Penasquitos 230 kV	115	126
Sycamore-Scripps 69 kV	Penasquitos-Old Town 230 kV and Sycamore-Penasquitos 230 kV	110	133
Chicarita-North City Metering Tap 138 kV	Penasquitos-Old Town 230 kV and Sycamore-Penasquitos 230 kV	105	117
Sycamore-Artesian 230 kV	Penasquitos-Old Town 230 kV and Sycamore-Penasquitos 230 kV	104	116
Mission-Friars 138 kV	Penasquitos-Old Town 230 kV and Sycamore-Penasquitos 230 kV	104	117
North City Metering Tap-Shadowridge 138 kV	Penasquitos-Old Town 230 kV and Sycamore-Penasquitos 230 kV	< 100	105

Table F.15-16: Friars-Doublet Tap deliverability constraint summary

Affected transmission zones		Baja, Imperial, San Diego	
		Base	Sensitivity
Generic Portfolio MW behind the constraint (installed FCDS capacity)		500	2155
Generic Battery storage portfolio MW behind the constraint (installed FCDS capacity)		500	1055
Deliverable Generic Portfolio MW w/o mitigation (Installed FCDS capacity)		0	0
Total undeliverable baseline and portfolio MW (Installed FCDS capacity)		1339	2604
Mitigation Options	RAS	RAS to trip Otay Mesa generation, not sufficient	
	Re-locate generic portfolio battery storage (MW)	Not adequate	
	Transmission upgrade	Option 1: SDGE Project Rearrange TL23013 PQ-OT and TL6959 PQ-Mira Sorrento	
		Option 2: Reconductor TL13810 DT-FR and TL13827 FR-MS	
Recommended Mitigation		SDGE Project Rearrange TL23013 PQ-OT and TL6959 PQ-Mira Sorrento	

**San Marcos-Melrose Tap constraint**

The deliverability of portfolio resources in the San Marcos-Melrose Tap area is limited by thermal overloading of the San Marcos-Melrose Tap as shown in Table F.15-17. These overloads were identified for the base and sensitivity portfolios. The constraints were seen in both the HSN and SSN scenarios, with the higher loadings being in the HSN scenario. Table F.15-18 shows the amount of portfolio generation that would be deliverable without any transmission upgrades.

The constraint can be partially mitigated by a tripping scheme to open the overloaded line. This is an interim solution, and to fully mitigate the overloads, transmission upgrades are required. Table F.15-18 shows the various mitigation options that were considered.

Table F.15-17: San Marcos-Melrose Tap constraints

Overloaded Facility	Contingency	Highest Loading (%) (HSN)	
		Base	Sensitivity
San Marcos-Melrose Tap 69 kV	San Luis Rey-Encina 230 kV and San Luis Rey-Encina-Palomar 230 kV	195	173
San Marcos-Melrose Tap 69 kV	San Luis Rey-Encina-Palomar 230 kV and Batiquitos-Shadowridge 138 kV	109	< 100
San Marcos-Melrose Tap 69 kV	San Luis Rey-Encina-Palomar 230 kV and Palomar-Batiquitos 138 kV	109	< 100
San Marcos-Melrose Tap 69 kV	San Luis Rey-Encina-Palomar 230 kV	109	< 100
San Marcos-Melrose Tap 69 kV	San Luis Rey-Encina-Palomar 230 kV and Encina-Palomar 138 kV	109	< 100

Table F.15-18: San Marcos-Melrose Tap deliverability constraint summary

Affected transmission zones		Baja, Imperial, San Diego	
		Base	Sensitivity
Generic Portfolio MW behind the constraint (installed FCDS capacity)		1189	2279
Generic Battery storage portfolio MW behind the constraint (installed FCDS capacity)		689	1179
Deliverable Generic Portfolio MW w/o mitigation (Installed FCDS capacity)		0	797
Total undeliverable baseline and portfolio MW (Installed FCDS capacity)		1784	1482
Mitigation Options	RAS	TL680 OLS - tripping scheme to open San Marcos- Melrose Tap 69 kV line, interim solution	
	Re-locate generic portfolio battery storage (MW)	Not adequate	
	Transmission upgrade	Reconductor TL680C San Marcos-Melrose Tap	
Recommended Mitigation		Reconductor TL680C San Marcos-Melrose Tap	

**Summary of SDG&E area mitigation plans**

As can be seen in the results above, an upgrade out of Imperial Valley 500 kV mitigates the East of Miguel constraint while also being effective in mitigating many of the overloads in the internal San Diego area. The following figures and tables show summaries of different mitigation packages that mitigate all identified constraints in the area.

Figure F.15-2: Alternative A1 Diagram

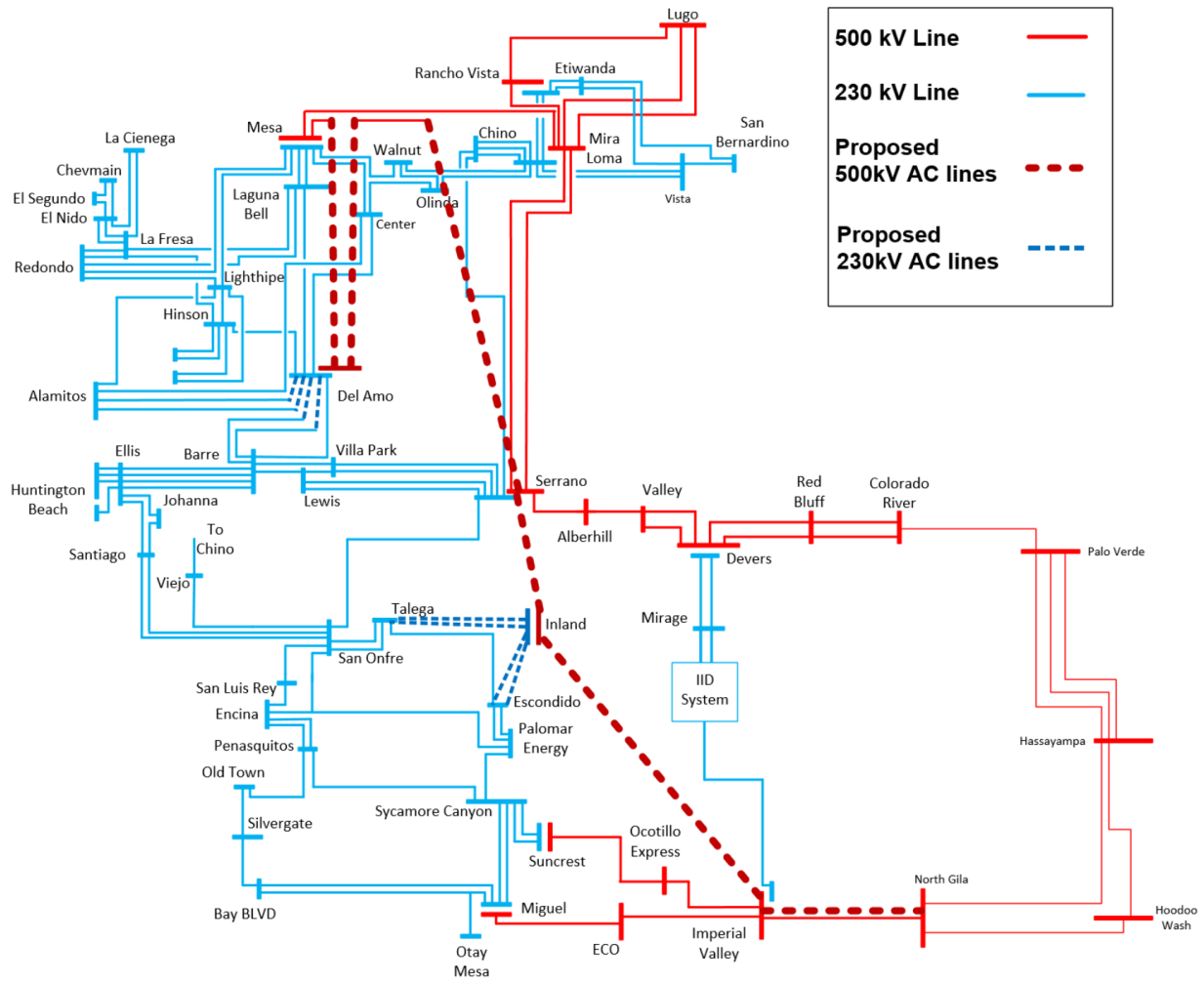



Table F.15-19: Summary of Mitigation Package for Alternative A1

<b>SDG&amp;E Area Alternative A1: North Gila–Imperial Valley–Inland–Serrano–Del Amo–Mesa 500kV AC Development</b>			
<b>Upgrade</b>	<b>Cost (\$M)</b>	<b>Base</b>	<b>Sensitivity</b>
Imperial Valley–Inland 500 kV Development: New Inland 500/230 kV Substation near Rainbow; three (3) 500/230 kV transformers; loop new substation to Talega and Escondido 230 substations utilizing upgraded and new 230 kV lines New Imperial Valley–Inland 500 kV line (~114 miles) with 50% series compensation	\$2411	x	x
New Inland–Serrano 500 kV line (~61 miles) with 50% series comp	\$1044	x	x
North Gila–Imperial Valley 500 kV 2 line New North Gila–Highline–Imperial Valley 500 kV line (~97 miles)	\$340	x	x
SDGE Project Rearrange TL23013 PQ-OT and TL6959 PQ-Mira Sorrento (removes P7 PQ-OT + SX-PQ contingency)	\$21	x	x
Reconductor TL680C San Marcos-Melrose Tap	\$28	x	x
3 ohm series reactor on Sycamore-Penasquitos 230 kV line	\$8		x
Upgrade TL13820 Sycamore-Chicarita 138 kV	\$60		x
Upgrade HW-NG and HA-NG lines and series capacitors to 3250 Amps	\$27	x	x
Reconductor Talega-San Onofre 230 kV to 912 MVA	\$40	x	x
Existing Miguel banks RAS	-		x
CEC RAS, under construction. Trip gen at Encina for P1 outages of Encina-San Luis Rey 230 kV or Encina-San Luis Rey-Palomar 230 kV	-	x	x
Use 2 hour emergency rating for Silvergate-Bay Boulevard 230 kV line	-	x	x
Use 30 min emergency rating for Silvergate-Old Town and Silvergate-Old Town Tap 230 kV lines	-	x	x
Use 30 min emergency rating for Encina Tap-San Luis Rey 230 kV line	-	x	x
Use 30 min emergency rating for San Luis Rey-San Onofre 230 kV #1 line	-	x	
Use 30 min emergency rating for Sycamore-Scripps 69 kV line	-		x

Figure F.15-3: Alternative A2 Diagram

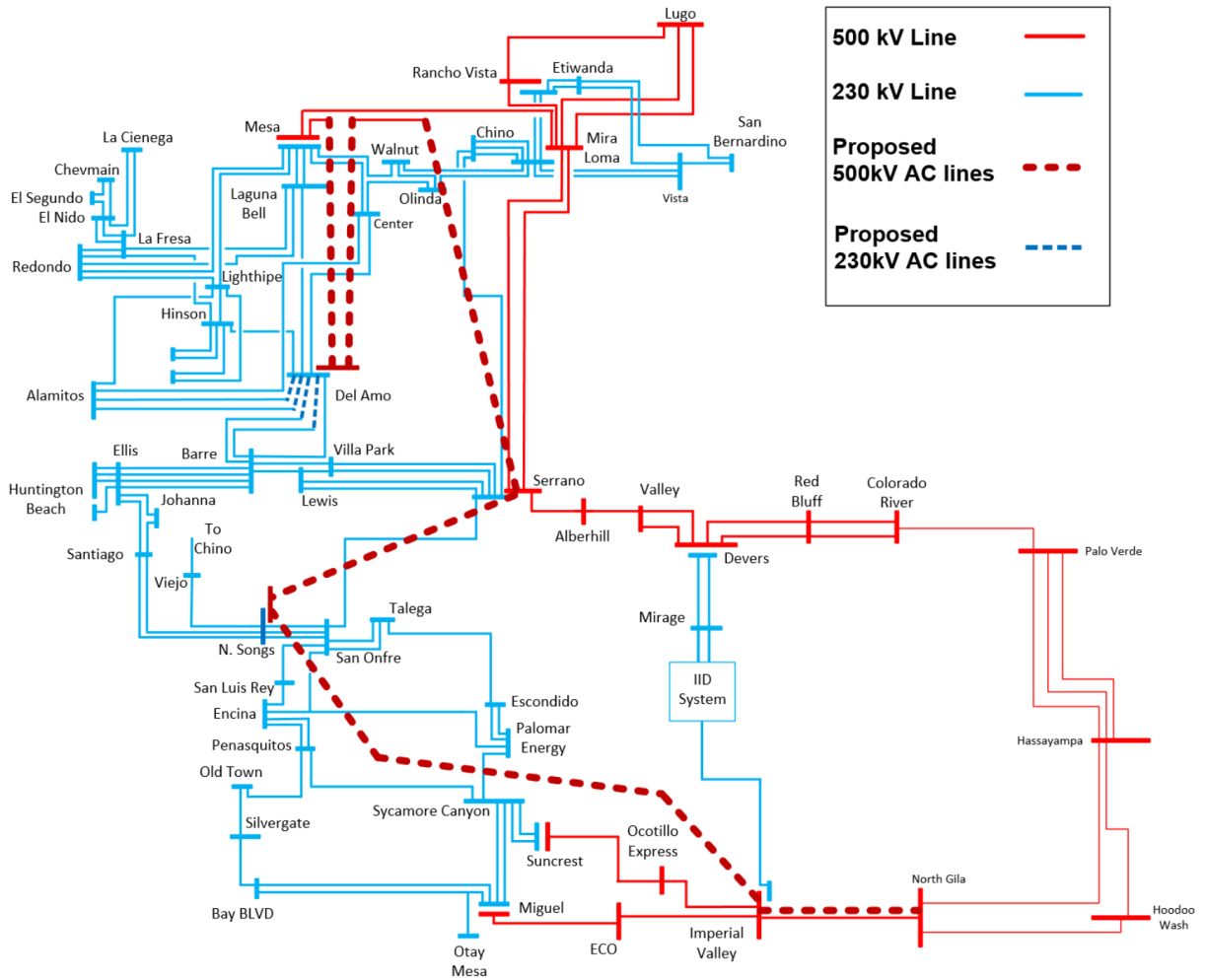

Table F.15-20: Summary of Mitigation Package for Alternative A2

<b>SDG&amp;E Area Alternative A2: North Gila–Imperial Valley–N.SONGS–Serrano–Del Amo–Mesa 500kV AC Development</b>			
<b>Upgrade</b>	<b>Cost (\$M)</b>	<b>Base</b>	<b>Sensitivity</b>
Imperial Valley–N. SONGS 500 kV Development: New 500/230 kV Substation north of SONGS, loop San Onofre–Santiago No. 1 & No. 2 and San Onofre–Viejo 230 kV lines into the new substation New Imperial Valley–N.SONGS 500 kV line (~145 miles) with 50% series compensation on the first segment; three (3) 500/230 kV transformers	\$2288	x	x
N. SONGS–Serrano 500 kV line (30 miles)	\$503	x	x
North Gila–Imperial Valley 500 kV 2 line New North Gila–Highline–Imperial Valley 500 kV line (~97 miles)	\$340	x	x
SDGE Project Rearrange TL23013 PQ-OT and TL6959 PQ-Mira Sorrento (removes P7 PQ-OT + SX-PQ contingency)	\$21		x
Reconductor TL680C San Marcos-Melrose Tap	\$28	x	x
3 ohm series reactor on Sycamore-Penasquitos 230 kV line	\$8		x
Upgrade TL13820 Sycamore-Chicarita 138 kV	\$60		x
Upgrade HW-NG and HA-NG lines and series capacitors to 3250 Amps	\$27		x
Existing Miguel banks RAS	-		x
CEC RAS, under construction. Trip gen at Encina for P1 outages of Encina-San Luis Rey 230 kV or Encina-San Luis Rey-Palomar 230 kV	-	x	
Use 2 hour emergency rating for Silvergate-Bay Boulevard 230 kV line	-		x
Use 30 min emergency rating for Silvergate-Old Town and Silvergate-Old Town Tap 230 kV lines	-	x	x
Use 30 min emergency rating for Encina Tap-San Luis Rey 230 kV line	-	x	
Use 30 min emergency rating for Sycamore-Scripps 69 kV line	-		x

Figure F.15-4: Alternative B1 Diagram

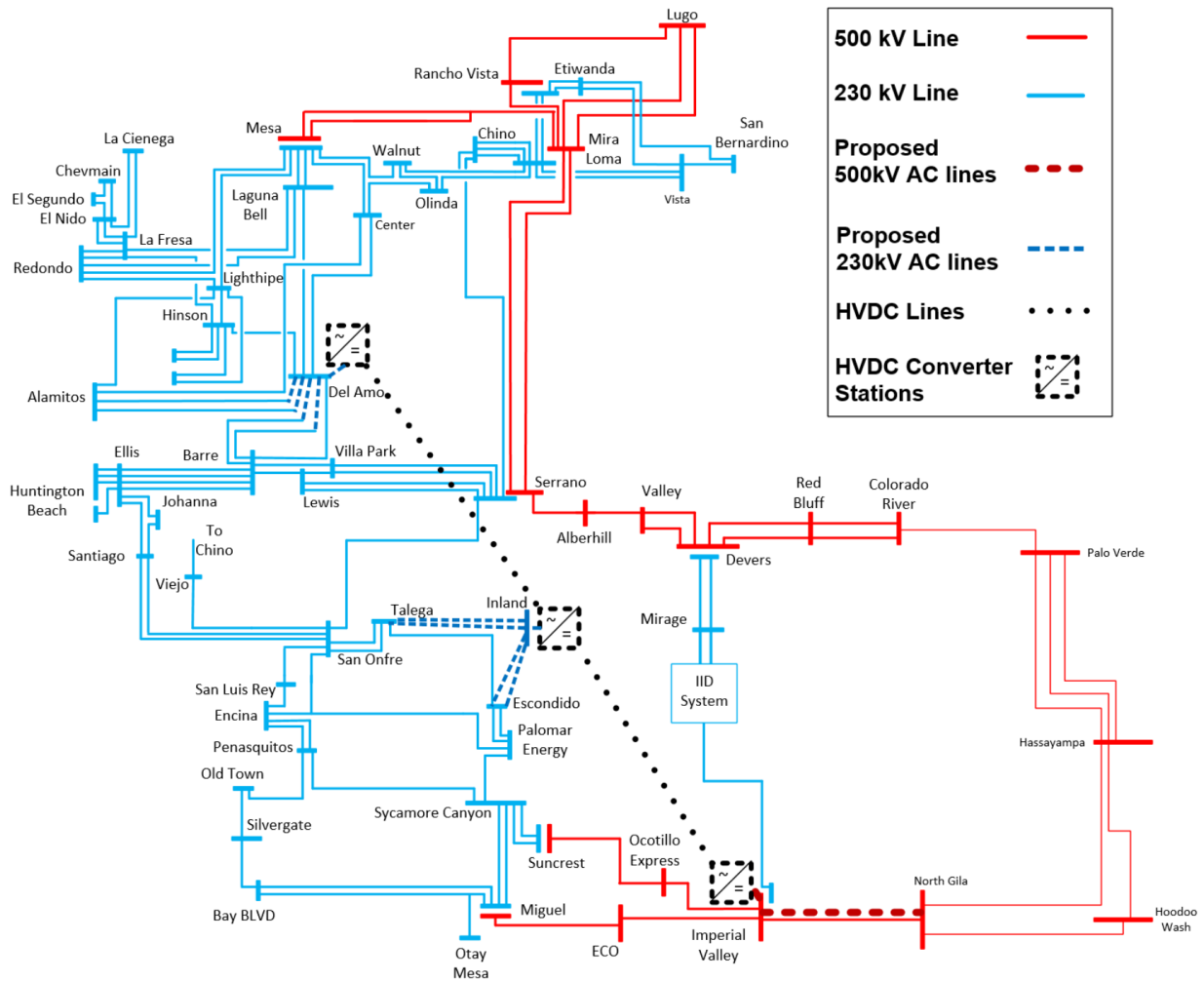

Table F.15-21: Summary of Mitigation Package for Alternative B1

<b>SDG&amp;E Area Alternative B1: North Gila–Imperial Valley 500 kV AC &amp; Imperial Valley–Inland–Del Amo HVDC 500 kV Development</b>			
<b>Upgrade</b>	<b>Cost (\$M)</b>	<b>Base</b>	<b>Sensitivity</b>
Imperial Valley–Inland 500 kV VSC-HVDC Development: New Inland 230 kV Substation near Rainbow Two new 2500 MW VSC-HVDC converter stations: one each at Imperial Valley 500 kV and Inland 230 kV New Imperial Valley–Inland 500 kV HVDC line (~145 miles); loop new substation to Talega and Escondido 230 kV substations utilizing upgraded and new 230 kV lines	\$3469	x	x
Inland–Del Amo 500 kV VSC–HVDC Development: One 2500 MW VSC-HVDC converter stations Del Amo 230 kV New Inland–Del Amo 500 kV HVDC line (~60 miles of overhead and ~20 miles is UG)	\$3182	x	x
North Gila–Imperial Valley 500 kV 2 line New North Gila–Highline–Imperial Valley 500 kV line (~97 miles)	\$340	x	x
SDGE Project Rearrange TL23013 PQ-OT and TL6959 PQ-Mira Sorrento (removes P7 PQ-OT + SX-PQ contingency)	\$21		x
reconductor TL680C San Marcos-Melrose Tap	\$28	x	x
3 ohm series reactor on Sycamore-Penasquitos 230 kV line	\$8		x
Upgrade TL13820 Sycamore-Chicarita 138 kV	\$60		x
Upgrade HW-NG and HA-NG lines and series capacitors to 3250 Amps	\$27		x
Reconductor Talega-San Onofre 230 kV to 912 MVA	\$40	x	x
Existing Miguel banks RAS	-		x
CEC RAS, under construction. Trip gen at Encina for P1 outages of Encina-San Luis Rey 230 kV or Encina-San Luis Rey-Palomar 230 kV	-	x	x
CEC RAS, under construction. Trip gen at Encina for P7 outage of San Luis Rey-San Onofre 230 kV #2 and #3	-	x	x
Use 2 hour emergency rating for Silvergate-Bay Boulevard 230 kV line	-	x	x
Use 30 min emergency rating for Silvergate-Old Town and Silvergate-Old Town Tap 230 kV lines	-	x	x
Use 30 min emergency rating for Encina Tap-San Luis Rey 230 kV line	-	x	x
Use 30 min emergency rating for San Luis Rey-San Onofre 230 kV #1 line	-	x	
Use 30 min emergency rating for Sycamore-Scripps 69 kV line	-		x



Table 15-22: Summary of Mitigation Package for Alternative B2

<b>SDG&amp;E Area Alternative B2: North Gila–Imperial Valley–N.SONGS AC &amp; N.SONGS–Del Amo HVDC 500 kV Development</b>			
<b>Upgrade</b>	<b>Cost (\$M)</b>	<b>Base</b>	<b>Sensitivity</b>
Imperial Valley–N. SONGS 500 kV Development: New 500/230 kV Substation north of SONGS, loop San Onofre–Santiago No. 1 & No. 2 and San Onofre–Viejo 230 kV lines into the new substation New Imperial Valley–N.SONGS 500 kV line (~145 miles) with 50% series compensation on the first segment; three (3) 500/230 kV transformers	\$2288	x	x
N.SONGS–Del Amo 500 kV HVDC Development: One 2500 MW VSC-HVDC converter stations at N. SONGS One 2500 MW VSC-HVDC converter station Del Amo 230 kV New Inland–Del Amo 500 kV HVDC line (~36 miles of overhead and ~20 miles is UG)	\$3838	x	x
North Gila–Imperial Valley 500 kV 2 line New North Gila–Highline–Imperial Valley 500 kV line (~97 miles)	\$340	x	x
SDGE Project Rearrange TL23013 PQ-OT and TL6959 PQ-Mira Sorrento (removes P7 PQ-OT + SX-PQ contingency)	\$21		x
Reconductor TL680C San Marcos-Melrose Tap	\$28	x	x
3 ohm series reactor on Sycamore-Penasquitos 230 kV line	\$8		x
Upgrade TL13820 Sycamore-Chicarita 138 kV	\$60		x
Upgrade HW-NG and HA-NG lines and series capacitors to 3250 Amps	\$27		x
Existing Miguel banks RAS	-		x
CEC RAS, under construction. Trip gen at Encina for P1 outages of Encina-San Luis Rey 230 kV or Encina-San Luis Rey-Palomar 230 kV	-	x	
Use 2 hour emergency rating for Silvergate-Bay Boulevard 230 kV line	-		x
Use 30 min emergency rating for Silvergate-Old Town and Silvergate-Old Town Tap 230 kV lines	-	x	x
Use 30 min emergency rating for Encina Tap-San Luis Rey 230 kV line	-	x	
Use 30 min emergency rating for Sycamore-Scripps 69 kV line	-		x





Table 15-23: Summary of Mitigation Package for Alternative C

<b>Alternative C: North Gila–Imperial Valley–Suncrest, Red Bluff–Devers–Mira Loma &amp; Serrano–Del Amo–Mesa 500 kV Development</b>			
<b>Upgrade</b>	<b>Cost (\$M)</b>	<b>Base</b>	<b>Sensitivity</b>
Imperial Valley-Suncrest #2 500 kV line (~89 miles)	\$1442	x	x
North Gila–Imperial Valley 500 kV 2 line New North Gila–Highline–Imperial Valley 500 kV line (~97 miles)	\$340	x	x
SDGE BES Project Part 1 Proposed projects in Suncrest/Miguel area - loop TL23021 SX-ML into Suncrest, add new 500/230kV bank at Miguel and Suncrest	\$375	x	x
SDGE BES Project Part 2 Old Town/Silvergate area - rebuild TL13822 Mission-Carlton Hills for a double 230 kV for looping TL23041 OM-ML-SX into Mission (Sycamore-San Luis Rey and Miguel-Mission #3). Reconductor TL23022 (ML-MS) and TL23023 (ML-MS) and TL23001 (SLR-MS) and TL23004 (SLR-MS). Install 2 phase shifter transformers at Mission (MS-ML and SX-SLR)	\$750	x	x
SDGE BES Project Part 3 Proposed projects in the San Luis Rey/San Onofre area - upgrade TL23006 SLR-SO to form new SLR-SO 230 kV #4 line	\$150	x	x
SDGE Project Rearrange TL23013 PQ-OT and TL6959 PQ-Mira Sorrento (removes P7 PQ-OT + SX-PQ contingency)	\$21	x	x
Reconductor TL680C San Marcos-Melrose Tap	\$28	x	x
3 ohm series reactor on Sycamore-Penasquitos 230 kV line	\$8		x
Upgrade TL13820 Sycamore-Chicarita 138 kV	\$60	x	x
Upgrade HW-NG and HA-NG lines and series capacitors to 3250 Amps	\$27		x
Sycamore-Suncrest 230 kV #3 , need higher rating for new line, at least 1000 MVA	\$90		x
Existing Suncrest RAS	-	x	x
CEC RAS, under construction. Trip gen at Encina for P1 outages of Encina-San Luis Rey 230 kV or Encina-San Luis Rey-Palomar 230 kV	-	x	x
Use 2 hour emergency rating for Silvergate-Bay Boulevard 230 kV line	-	x	x
Use 30 min emergency rating for Silvergate-Old Town and Silvergate-Old Town Tap 230 kV lines	-	x	x
Use 30 min emergency rating for Encina Tap-San Luis Rey 230 kV line	-	x	x
Use 30 min emergency rating for Sycamore-Scripps 69 kV line	-		x

### F.15.2 Off-peak results

All portfolio resources inside and outside the SDG&E area that are likely impact off-peak deliverability constraints in the SDG&E area are shown in Table F.15-24.

Table F.15-24: Generic portfolio resources likely to impact off-deliverability constraints in SDG&E area

RESOLVE Resource Name	FCDS + EO (MW)		
	2032 Base Portfolio	2035 Sensitivity Portfolio	Difference
Arizona_Li_Battery	759	1,798	1,039
Arizona_Solar	1,881	3,226	1,345
Baja_California_Wind	600	600	-
Greater_Imperial_Geothermal	600	900	300
Imperial_Li_Battery	10	375	365
Imperial_Solar	300	653	353
Riverside_East_Pumped_Storage	-	700	700
Riverside_Li_Battery	-	1,538	1,538
Riverside_Solar	-	2,999	2,999
San_Diego_Li_Battery	749	1,104	355
San_Diego_Pumped_Storage	500	500	-
<b>Total FCDS + EO</b>	<b>5,399</b>	<b>14,393</b>	<b>8,994</b>

### East of Miguel off-peak deliverability constraint

Wind and solar resources in the East of Miguel area are subject to curtailment in the base and sensitivity portfolios due to loading limitations on transformers and lines as shown in Table F.15-25. These constraints were also identified in the peak deliverability assessment, and flows are higher in the peak study. Mitigation proposed for the peak constraints will also mitigate the off-peak constraints.

Table F.15-25: East of Miguel off-peak deliverability constraint

Overloaded Facility	Contingency	Loading (%)	
		Base	Sensitivity
Miguel Bank 81 500/230 kV #2	Miguel Bank 80 500/230 kV #1	108	130
Miguel Bank 80 500/230 kV #1	Miguel Bank 81 500/230 kV #2	111	134
Miguel Bank 80 500/230 kV #1	OCO-Suncrest 500 kV	< 100	105
Miguel Bank 80 500/230 kV #1	Sycamore-Suncrest 230 kV #1 and #2	< 100	104
Miguel Bank 80 500/230 kV #1	Imperial Valley-OCO 500 kV	< 100	103
Miguel Bank 80 500/230 kV #1	Miguel Bank 81 500/230 kV #2	109	131
Miguel Bank 80 500/230 kV #1	OCO-Suncrest 500 kV	< 100	101
Miguel Bank 80 500/230 kV #1	Sycamore-Suncrest 230 kV #1 and #2	< 100	101
Sycamore-Suncrest 230 kV #1	ECO-Miguel 500 kV	101	124
Sycamore-Suncrest 230 kV #1	Sycamore-Suncrest 230 kV #2	101	122
Sycamore-Suncrest 230 kV #1	Imperial Valley-ECO 500 kV	< 100	107
Sycamore-Suncrest 230 kV #2	ECO-Miguel 500 kV	101	124
Sycamore-Suncrest 230 kV #2	Sycamore-Suncrest 230 kV #1	101	122
Sycamore-Suncrest 230 kV #2	Imperial Valley-ECO 500 kV	< 100	107
ECO-Miguel 500 kV	OCO-Suncrest 500 kV	< 100	106
ECO-Miguel 500 kV	Sycamore-Suncrest 230 kV #1 and #2	< 100	106
ECO-Miguel 500 kV	Imperial Valley-OCO 500 kV	< 100	103

Table F.15-26: East of Miguel off-peak deliverability constraint summary

Affected renewable transmission zones		Arizona, Baja, Imperial	
		Base	Sensitivity
Generic renewable portfolio MW behind the constraint (installed capacity)		2781	4479
Energy storage (ES) portfolio MW behind the constraint (installed capacity)		769	2173
Renewable curtailment without mitigation (MW) (installed capacity)		1956	3833
Mitigation Options:	Portfolio ES (in charging mode) (MW) <sup>43</sup>	Not applicable	
	RAS	<ul style="list-style-type: none"> <li>Existing TL23054/TL23055 RAS, not sufficient</li> </ul>	

<sup>43</sup> The Portfolio energy storage (in charging mode) amount is the amount needed to mitigate the constraint after baseline battery storage is fully utilized.

		<ul style="list-style-type: none"> <li>Existing Miguel Bank 80 and 81 RAS, not sufficient</li> </ul>
	Additional battery storage (MW)	Not applicable
	Transmission upgrades	500 kV mitigation out of Imperial Valley (see SDG&E on-peak summary section for details of considered options)
Recommended Mitigation		See the Conclusions and Recommendations for the SCE Metro and Eastern and SDG&E Area Mitigation Plan

### F.15.3 Conclusions and Recommendations for the SCE Metro and Eastern and SDG&E Area Mitigation Plan

For the major constraints identified in the SCE Eastern and Metro areas and the SDG&E area, the ISO found that they could be met by common upgrades that would meet the needs of each of the areas. Sections F.13, F.15 and F.15 described the transmission analysis and the alternatives identified for these three areas. The SDG&E and SCE Eastern areas required major new transmission facilities to address the constraints in each of those areas. Eastern Area Alternative 3 described in Section F.14.1 and SDG&E Area Alternative 4 describe alternatives focused on meeting only the needs of those individual areas. These two alternatives are described below as the combined Alternative C. However, Alternatives A1, A2, B1, B2 and B3 also described below focus on including major upgrades that would meet the needs of both areas. Transmission upgrades were also found to be needed in the SCE Metro area. However, the selection of upgrades needed in the Metro area depends on the upgrades selected to meet the needs in the SCE Eastern and SDG&E areas. Constraints were identified between Serrano and Barre substations and South of Mesa substation. Metro Area Alternative 2 would address those constraints and is included in Alternatives A1 and A2 described below. However, a new HVDC line terminated at Del Amo Substation that is included in Alternatives B1, B2 and B3 would also address those Metro Area needs. Alternatives A1 and A2 have a lower cost than Alternatives B1, B2 and B3. Alternatives A1 and A2 also have a lower cost than Alternative C. Alternatives A1 and A2 are very similar. Both include a new 500 kV AC transmission line between Imperial Valley and Serrano. Alternative A1 loops that line into a new Inland 500/230 kV substation that connects to Escondido and Talega substation via 230 kV lines. Alternative A2 loops the new 500 kV line into a new 500/230 kV substation connected to the 230 kV lines north of SONGS 230 kV substation. The analysis of Alternative A2 determined that some upgrades within the SDG&E area needed with Alternative A1 could be avoided. Therefore, Alternative A2 has a lower estimated cost, so it is the preferred alternative. All of the alternatives include new transmission lines and all of these transmission lines are considered to be very challenging in terms of obtaining a CPCN. HVDC Alternatives B1, B2 and B3 would allow undergrounding some of the overhead transmission lines and address visual environmental impacts but would have a significantly higher cost. The costs for Alternatives B1, B2 and B3 are higher because of the required HVDC inverter stations. The costs of these HVDC alternatives take into account the lower cost of overhead HVDC lines compared to AC lines but also include the higher cost of undergrounding about 20 miles of HVDC line section in the LA Metro area to get to the Del Amo Substation. The cost estimates for 500 kV AC Alternatives A1, A2 and C assume overhead construction to get to Del Amo because they are

based on maximizing the utilization of existing 500 kV AC facilities and taking into consideration the opportunity presented by coordinating the construction of the 500 kV facilities with MWD's planned pipe line project, which according to SCE utilize's the same SCE right of way as the 500 kV facilities.

Table F.15-27: Summary of combined SCE Eastern, SCE Metro and SDG&E transmission development alternatives

Alt	Description	Total Cost Base Portfolio (\$M)	Total Cost Sensitivity Portfolio (\$M)	Overall Cost Based Rank
A1	North Gila–Imperial Valley–Inland*–Serrano–Del Amo*–Mesa 500kV AC Development	\$5,462	\$5,645	2
A2	North Gila–Imperial Valley–N.SONGS*–Serrano–Del Amo*–Mesa 500kV AC Development	\$4,710	\$4,853	1
B1	North Gila–Imperial Valley AC & Imperial Valley**–Inland**–Del Amo** HVDC 500 kV Development	\$7,506	\$7,089	4
B2	North Gila–Imperial Valley–N.SONGS* AC & N.SONGS**–Del Amo** HVDC 500 kV Development	\$7,017	\$7,160	3
B3	North Gila–Imperial Valley–Inland* AC & Inland**–Del Amo** HVDC 500 kV Development	\$7,614	\$7,797	5
C	North Gila–Imperial Valley–Suncrest, Red Bluff–Devers–Mira Loma and Serrano–Delamo–Mesa 500 kV AC Development	\$7,290	\$8,798	6

\* denotes new 500/230 kV AC substation\*\* denotes new VSC-HVDC converter station

Based on the above considerations Alternative A2, the North Gila–Imperial Valley–N.SONGS–Serrano–Del Amo–Mesa 500kV AC Development is recommended for approval in the current planning cycle. The project has an overall cost of \$4,718 million and an estimated overall in service date of 2035. The project has the following overall scope.

Table F.15-28: Recommended Southeast California Transmission Development

	Description	Cost(\$M, 2022\$)	Estimated ISD
1	<b><u>North Gila–Imperial Valley 500 kV Development</u></b> <ul style="list-style-type: none"> <li>New North Gila–Imperial Valley 500 kV line (~97 miles)<sup>44</sup></li> </ul>	\$340	2027
2	<b><u>Imperial Valley–N. SONGS 500 kV AC Development</u></b> <ul style="list-style-type: none"> <li>New 500/230 kV Substation north of SONGS c/w three (3) 500/230 kV transformers; loop San Onofre–Santiago No. 1 &amp; No. 2 and San Onofre–Viejo 230 kV lines into the new substation</li> <li>New Imperial Valley–N.SONGS 500 kV line (~145 miles) with 50% series compensation on the first segment</li> </ul>	\$2,288	2033
3	<b><u>N. SONGS–Serrano 500 kV AC line (30 miles)</u></b>	\$503	2033
4	<b><u>New Serrano–Del Amo–Mesa 500 kV Development</u></b> <ul style="list-style-type: none"> <li>New 500 kV switchyard at Del Amo c/w three (3) 500/230 kV transformers</li> <li>Create a new Serrano – Del Amo – Mesa 500 kV lines utilizing existing and a total of ~28 miles of new single/double circuit 500 kV line sections</li> <li>Loop Alamitos–Barre No. 1 and No. 2 230 kV lines into Del Amo Substation</li> </ul>	\$1,125	2033
5	<b><u>Other SDG&amp;E area upgrades</u></b>	\$28	See SDG&E area section
6	<b><u>SCE Eastern area 500kV and 230 kV line upgrades (Six 500 kV, three 230 kV)</u></b>	\$426	2029 (500 kV)
	<b>Total</b>	\$4,710	

<sup>44</sup> The ISO has discussed with IID the possibility of a joint project where IID would include a New Dunes 500 kV switchyard at IID Highline Substation one (1) 500/230 kV transformer, and the N. Gila- Imperial Valley line would be looped into that substation.

## **F.16 Offshore Wind**

### **F.16.1 Morro Bay Area**

In the Morro Bay area the base portfolio included 1,588 MW and the sensitivity portfolio included 3,100 MW of offshore wind. For the interconnection of the offshore wind, the existing Diablo 500 kV substation has been identified and is where current offshore wind interconnection requests in the ISO queue are primarily located. The ISO has also considered the alternative of creating a new 500 kV substation on the Diablo-Gates 500 kV for the interconnection of the Morro Bay area offshore wind. The ISO will continue to coordinate with PG&E and the offshore resource developers, which were the successful BOEM lease bidders, for the interconnection point for the Morro Bay area offshore wind.

### **F.16.2 Humboldt off shore wind interconnection sensitivity**

In the Humboldt area the base portfolio included 120 MW (Energy Only) and the sensitivity portfolio included 1,607 MW (1,487 MW FCDS and 120 MW EO) of offshore wind. There are no existing bulk substation in the vicinity of Humboldt offshore wind. Similar to the offshore wind sensitivity studies performed in the 2021-2022 TPP, three options were considered to interconnect Humboldt offshore wind to the rest of the system. These options along with the study results are detailed in the following sections.

#### Option 1: 500 kV AC line to Fern Road 500 kV substation

Fern Road 500 kV substation is planned to be in service in 2024 as part of the Round Mountain Dynamic Reactive Support (DRS) project that is located approximately 11 miles south of Round Mountain substation. In this option, it is assumed that two, approximately 120 mile, 500 kV AC lines will interconnect the project to the Fern Road substation (Figure F.16-1). The cost estimate for this interconnection option-1 is \$1.2B.

Figure F.16-1: AC Option to Interconnect Humboldt Bay Offshore Wind (Option-1)

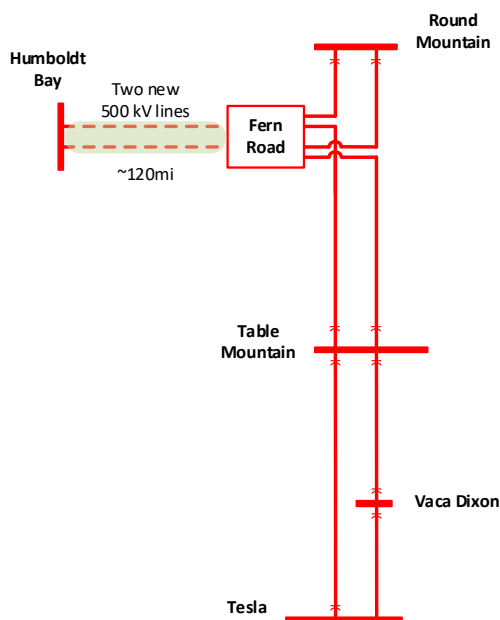

Table F.16-1: Summary of Constraints for Humboldt Bay Offshore Wind (Option-1)

Constraint	Contingency	Overload Percentage	Generic Portfolio MW behind the constraint (installed FCDS capacity)	Generic Battery storage portfolio MW behind the constraint (installed FCDS capacity)	Deliverable Generic Portfolio MW w/o mitigation (Installed FCDS capacity)	Total undeliverable baseline and portfolio MW (Installed FCDS capacity)	Potential Mitigation
Table Mountain-Vaca Dixon 500 kV line	Base Case	120	1759	137	515	1450	New Table Mt - Vaca Dixon 500 kV line
Tesla-Collinsville 500 kV line	Table Mountain-Vaca Dixon 500 kV line	107	6222	5622	9932	2273	New Table Mt - Vaca Dixon 500 kV line
Round Mountain-Cottonwood 230 kV line #2	Table Mountain-Vaca Dixon 500 kV line	100	1601	0	1602	21	New Table Mt - Vaca Dixon 500 kV line
Round Mountain-Cottonwood 230 kV line #3	Table Mountain-Vaca Dixon 500 kV line	109	1601	0	1071	551	New Table Mt - Vaca Dixon 500 kV line
Collinsville-Pittsburg E 230 kV line	Collinsville-Pittsburg F 230 kV line	139	1527	0	0	2629	Reduce the overall series compensation on the Table Mountain-Vaca-



Constraint	Contingency	Overload Percentage	Generic Portfolio MW behind the constraint (installed FCDS capacity)	Generic Battery storage portfolio MW behind the constraint (installed FCDS capacity)	Deliverable Generic Portfolio MW w/o mitigation (Installed FCDS capacity)	Total undeliverable baseline and portfolio MW (Installed FCDS capacity)	Potential Mitigation
							Collinsville-Tesla 500 kV path.
Collinsville-Pittsburg F 230 kV line	Collinsville-Pittsburg E 230 kV line	128	1527	0	0	2594	Reduce the overall series compensation on the Table Mountain-Vaca-Collinsville-Tesla 500 kV path.
N Dublin-Vineyard 230 kV line	Contra Costa-Moraga Nos. 1 & 2 230 kV lines	103	130	150	251	29	Contra Costa - Lone Tree Series compensation TPP project
E Shore-San Mateo 230 kV line	Newark-Ravenswood and Tesla-Ravenswood 230 kV lines	120	0	0	0	459	Reconductor
Pittsburg-E Shore 230 kV line	Newark-Ravenswood and Tesla-Ravenswood 230 kV lines	114	0	0	0	607	Reconductor
USWP-JRW-Cayetano 230 kV line	Contra Costa-Moraga Nos. 1 & 2 230 kV lines	109	120	70	0	447	Contra Costa - Lone Tree Series compensation TPP project
Cortina-Cache Jct 115 kV line	Vaca-Lakeville & Vaca-Tuluca 230 kV lines	116	49	0	0	408	Reconductor
RBRocklinJCT-PLSNT GR 115 kV line	Rio Oso-Atlantic & Rio Oso-Gold Hill 230 kV lines	106	119	122	60	185	Reconductor

Option 2: VSC-HVDC subsea cable connection to a converter station in the Bay area

In this option, it is assumed that a VSC-HVDC link will connect the Humboldt offshore wind to a new Bay Hub substation in the Bay area through a subsea cable. Three cables will then connect the Bay Hub 230 kV substation to major load centers in the area (Figure F.16-2). Currently the three load centers selected are Potrero, East Shore and Los Esteros 230 kV substations. These injection locations need to be fine tuned to address any potential constraints associated with this interconnection option if this option is considered for further evaluation. The cost estimate for interconnection option 2 is \$4B.

Figure F.16-2: VSC-HVDC Option to Interconnect Humboldt Bay Offshore Wind (Option 2)

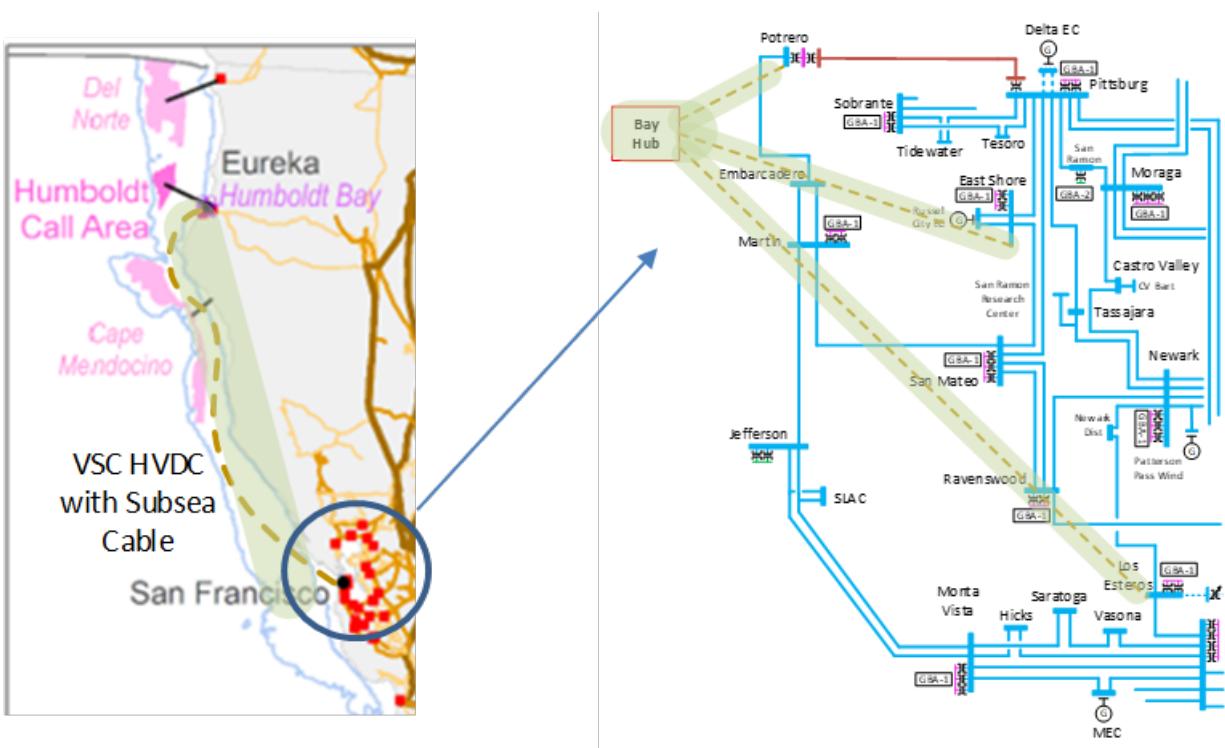

Table F.16-2: Summary of Constraints for Humboldt Bay Offshore Wind (Option-1)

Constraint	Contingency	Overload Percentage	Generic Portfolio MW behind the constraint (installed FCDS capacity)	Generic Battery storage portfolio MW behind the constraint (installed FCDS capacity)	Deliverable Generic Portfolio MW w/o mitigation (Installed FCDS capacity)	Total undeliverable baseline and portfolio MW (Installed FCDS capacity)	Potential Mitigation
Collinsville - Pittsburg E 230 kV	Collinsville - Pittsburg F 230 kV	115	40	0	0	1142	Reduce the overall series compensation on the Table Mountain-Vaca-Collinsville-Tesla 500 kV path.
E Shore-San Mateo 230 kV line	BayHub - Potrero 230 kV Line	107	1487	0	1237	250	Reconductor or fine tune Injection point
Cortina-Cache Jct 115 kV line	Vaca-Lakeville & Vaca-Tuluca 230 kV lines	110	49	0	0	408	Reconductor or fine tune Injection point
East Shore 230/115 kV Transformer Bank 1 or 2	E. SHORE 230/115 kV TB 2 or 1	113	1506	190	887	809	Replace Transformer or fine tune Injection Point

Constraint	Contingency	Overload Percentage	Generic Portfolio MW behind the constraint (installed FCDS capacity)	Generic Battery storage portfolio MW behind the constraint (installed FCDS capacity)	Deliverable Generic Portfolio MW w/o mitigation (Installed FCDS capacity)	Total undeliverable baseline and portfolio MW (Installed FCDS capacity)	Potential Mitigation
Embarcadero - Potrero 230 kV line	Potrero 230/115 kV Transformer Bank #1	118	1487	0	921	566	Reconductor or fine tune Injection point
Potrero 230/115 kV Transformer Bank #1	Embarcadero - Potrero 115 kV Line	104	1487	0	1310	177	Reconductor or fine tune Injection point
Los Esteros - Nortech 115 kV Line	Basecase	105	1497	1132	570	0	Reconductor or fine tune Injection point

Option 3: LCC HVDC Bipole to Collinsville 500/230 kV substation

The new Collinsville 550/230 kV substation project was approved as a policy project in 2021-2022 TPP. The project includes looping of the Vaca Dixon – Tesla 500 kV line with two new 230 kV connections to the existing Pittsburg 230 kV substation. In this study it is assumed that the Humboldt Bay offshore wind will be connected to the new Collinsville substation with an HVDC bipole link (Figure F.16-3). The cost estimate for this interconnection option 3 is \$3B.

Figure F.16-3: LCC HVDC Option to Interconnect Humboldt Bay Offshore Wind (Option 3)

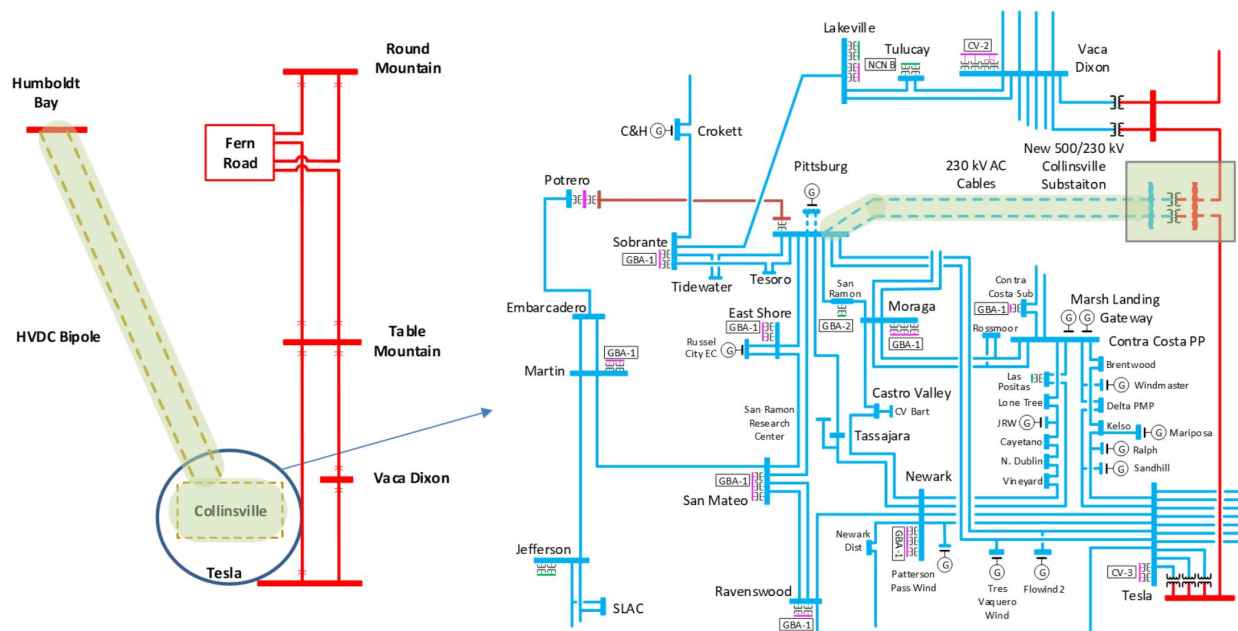

Separate base cases were developed for the deliverability studies for each of the above three options for the Humboldt offshore wind interconnection. The results of the on-peak and off-peak deliverability studies are provided in the following sections.

Table F.16-3: Summary of Constraints for Humboldt Bay Offshore Wind (Option-3)

Constraint	Contingency	Overload Percentage	Generic Portfolio MW behind the constraint (installed FCDS capacity)	Generic Battery storage portfolio MW behind the constraint (installed FCDS capacity)	Deliverable Generic Portfolio MW w/o mitigation (Installed FCDS capacity)	Total undeliverable baseline and portfolio MW (Installed FCDS capacity)	Potential Mitigation
Collisville-Pittsburg E 230 kV line	Collisville-Pittsburg F 230 kV line	143	1527	0	0	2629	Reduce the overall series compensation on the Table Mountain-Vaca-Collisville-Tesla 500 kV path.
Collisville-Pittsburg F 230 kV line	Collisville-Pittsburg E 230 kV line	143	1527	0	0	2594	Reduce the overall series compensation on the Table Mountain-Vaca-Collisville-Tesla 500 kV path.
N Dublin-Vineyard 230 kV line	Contra Costa-Moraga Nos. 1 & 2 230 kV lines	102	130	150	257	23	Contra Costa - Lone Tree Serise compensation TPP project
E Shore-San Mateo 230 kV line	Newark-Ravenswood and Tesla-Ravenswood 230 kV lines	119	0	0	0	466	Reconductor
Pittsburg-E Shore 230 kV line	Newark-Ravenswood and Tesla-Ravenswood 230 kV lines	115	0	0	0	607	Reconductor find line name
USWP-JRW-Cayetano 230 kV line	Contra Costa-Moraga Nos. 1 & 2 230 kV lines	108	120	70	0	431	Contra Costa - Lone Tree Serise compensation TPP project
Cortina-Cache Jct 115 kV line	Vaca-Lakeville & Vaca-Tulucay 230 kV lines	112	49	0	0	408	Reconductor
Pease-E Mry 60 kV line	Palermo-Nicolaus & Palermo_E.MRY J2 115 kV lines	101	0	0	0	5	Reconductor
RBRocklinJCT-PLSNT GR 115 kV line	Rio Oso-Atlantic & Rio Oso-Gold Hill 230 kV lines	102	119	122	185	60	Reconductor

The base resource portfolio provided by the CPUC for the 2022-2023 Transmission Plan does not support need for transmission capacity from the North Coast in this year's studies, with 100-150 MW of offshore wind mapped to the Humboldt area as Energy Only. The need for new transmission from the North Coast area was identified in studying the sensitivity portfolio. The ISO also notes that the base portfolio for the 2023-2024 transmission plan will necessitate new transmission, with 1.6 GW of offshore wind mapped to the north coast/Humboldt area<sup>45</sup>.

Given the resource portfolios provided for this year's transmission planning studies and the state's progress of resource development planning activities (supply chains, harbors, etc.) with the CEC AB 525 report due in June 2023, the ISO is not recommending approval of transmission solutions in this planning cycle and will look instead to advancing upgrades in the The assessment of alternatives in this planning cycle conducted on the sensitivity portfolio and documented in Appendix F will assist in being positioned to make a decision for the recommended transmission for the North Coast in the 2023-2024 Transmission Plan.

## F.17 Out-of-State Wind

The base portfolio includes 1,500 MW of out-of-state wind resources (1,062 MW from Wyoming or Idaho and 438 MW from New Mexico) and the sensitivity portfolio includes 4,832 MW (1,500 MW from Wyoming, 1,000 MW from Idaho and 2,328 MW from New Mexico). These resources have been identified by CPUC as requiring new transmission and have been included in the policy analysis and alternative analysis as expanding the maximum import capability of the paths to import the out-of-state wind to determine the CAISO internal transmission needs required to accommodate the out-of-state wind identified. Further, the ISO also notes that the base portfolio for the 2023-2024 transmission plan reflects the same volumes and sources of out-of-state wind as this year's sensitivity.<sup>46</sup>

Two out-of-state subscriber transmission developments to accommodate the wind resources in Wyoming (TransWest Express) and New Mexico (Sunzia) are currently underway.

The ISO is continuing to assess the SWIP North project proposed by LS Power for accessing wind resources in Idaho given the resource portfolios being studied in this year's planning analysis and the base portfolio for the 2023-2024 Transmission Plan. The ISO's economic studies also demonstrate other economic benefits contributing to the overall value provided by the project, as set out in Chapter 4. Idaho Power has expressed interest in the SWIP North project and the ISO has initiated discussions with Idaho Power about joint participation. Idaho Power has expressed an interest in South to North capacity, though potentially not for the full 1,000 MW of capability. The ISO notes there may be opportunities for DOE funding for unutilized capacity that the ISO is currently exploring. Idaho Power is currently performing a detailed analysis of the SWIP North project in its 2023 IRP which will be filed with its Public

---

<sup>45</sup> CPUC Decision (D.) 23-02-040 adopted on February 23, 2023.

<sup>46</sup> CPUC Decision (D.) 23-02-040 adopted on February 23, 2023.

Utilities Commission by September 30th. The filing, originally planned for June, had to be extended due to the nature of analysis being performed.

The SWIP North project does not meet the criteria defining interregional transmission projects, as set out in the ISO's tariff. Accordingly, the ISO intends to work with Idaho Power and other potential interested transmission service providers and continue the development of a recommendation for the SWIP North project, as a potential regional policy-driven project. This will be conducted as an extension to this planning cycle.

Both the SWIP North project and the TransWest Express project would deliver significant quantities of out-of-state wind into the Harry Allen-Eldorado area, and the combined impact on existing WECC Paths in the area will need to be addressed.

## **F.18 Transmission Plan Deliverability with Approved Transmission Upgrades**

As part of the coordination with other ISO processes and as set out in Appendix DD (GIDAP) of the ISO tariff, the ISO monitors the available transmission plan deliverability (TPD) in areas where the amount of generation in the interconnection queue exceeds the available deliverability, as identified in the generator interconnection cluster studies. In areas where the amount of generation in the interconnection queue is less than the available deliverability, the transmission plan deliverability is sufficient. An estimate of the generation deliverability supported by the existing system and approved upgrades is provided in the transmission capability estimates white paper the ISO published in October 2021<sup>47</sup>. The white paper considered queue clusters up to and including queue cluster 13. The transmission plan deliverability is estimated based on the area deliverability constraints identified in recent generation interconnection studies without considering local deliverability constraints. The white paper provides the deliverable study amount beyond the existing and contracted resources provided by the CPUC for the 2020-2021 planning cycle.

## **F.19 Production production cost model (PCM) results**

The Base portfolio and the sensitivity portfolio were described in section F.4 were utilized for the PCM study in the policy-driven assessment in this planning cycle. Details of PCM assumptions and development can be found in Chapter 4. In this planning cycle, the Sensitivity portfolio PCM used the CEC 2021 IEPR 2035 load forecast with high electrification, while the Base portfolio PCM used the CEC 2021 IEPR 2032 load forecast with high electrification

As the Base portfolio PCM was used for the ISO economic assessment, the congestion and curtailment analysis of the Base portfolio PCM was discussed in Chapter 4. Only the Sensitivity portfolio PCM results were included in this section. Compared with the Base portfolio PCM congestin and curtailment results as set out in section 4.7, congestion and curtailment significantly increased in many areas, which was mainly due to the changes in resource portfolio. The change in load forecast in the Sensitivity portfolio 2035 PCM case also contributed

---

<sup>47</sup> <http://www.caiso.com/Documents/RevisedWhitePaper-2021TransmissionCapabilityEstimates-CPUCResourcePlanningProcess.pdf>.

to the increase in congestion in some areas, for example, SCE Western LA area and PG&E Greater Bay area.

Among all differences between the Base and the Sensitivity portfolios, there are incremental 1487 MW of Humboldt Bay offshore wind in the Sensitivity portfolio. Similar to the last planning cycle, three transmission interconnection alternatives for the incremental Humboldt Bay offshore wind were studied:

- Alternative 1 – The 1487 MW of Humboldt Bay offshore wind is injecting at the Fern Road 500 kV bus.
- Alternative 2 - The 1487 MW of Humboldt Bay offshore wind is injecting at the proposed BayHub 230 kV bus.
- Alternative 3 - The 1487 MW of Humboldt Bay offshore wind is injecting at the Collinsville 500 kV bus, which was a approved transmission upgrade in the last planning cycle.

Simulation results shows that the impacts on transmission congestion of these three alternatives are different. Among these three alternatives, the Alternative 1 has the largest COI corridor congestion, the Alternative 3 has the largest Collinsville-Pittsburg 230 kV corridor congestion, while the Alternative 2 has the Greater Bay area congestion increased. These three offshore wind transmission alternatives has similar impact on the overall system renewable curtailment, however, the Alternative 1 with the Humboldt offshore wind modeled at the Fernroad 500 kV bus has the lowest Humboldt offshore wind curtailment among all three alternatives. Detailed production cost simulation results are included in Appendix G.