



May 23, 2014

The Honorable Kimberly D. Bose
Secretary
Federal Energy Regulatory Commission
888 First Street, NE
Washington, DC 20426

**Re: California Independent System Operator Corporation
Filing of CAISO Service Agreement No. 3008
Docket No. ER14-____-000**

Dear Secretary Bose:

The California Independent System Operator Corporation (“CAISO”) submits for filing and acceptance an Approved Project Sponsor Agreement (“APSA”) dated March 10, 2014, between the CAISO and the Imperial Irrigation District (“IID”).¹ The IID APSA sets forth the terms under which IID will construct the Imperial Valley Element, a transmission project approved through the CAISO’s transmission planning process and the first one for which a project sponsor was approved through the competitive solicitation process. The CAISO requests that the Commission accept the APSA effective July 23, 2014.

I. Transmission Planning Process Background and Overview of Approved Project Sponsor Agreement Development

The CAISO’s annual transmission planning process consists of three phases. In phase one, the CAISO identifies study assumptions and develops a study plan.² During phase two, the CAISO identifies the need for reliability-driven, public policy-driven and economic transmission solutions and develops the transmission solutions that most cost effectively and efficiently meet those needs.³ These transmission solutions are set forth in a transmission plan that is approved by the CAISO’s Board of Governors at the end of phase 2. In addition, the tariff authorizes CAISO management to approve solutions with capital costs of \$50 million or less, and if such solutions are urgently needed, the

¹ The CAISO submits the APSA pursuant to Section 205 of the Federal Power Act, 16 U.S.C. § 824d (2012), and Rule 205 of the Commission’s Rules of Practice and Procedure, 18.C.F.R. § 385.205 (2013).

² CAISO tariff § 24.3.

³ CAISO tariff § 24.4.

CAISO may accelerate the competitive solicitation process ahead of other solutions.⁴ During phase 3, the CAISO selects project sponsors for the transmission solutions that are eligible for competitive solicitation.⁵

The CAISO identified the Imperial Valley Element as a policy-driven transmission solution needed to support renewable generation in the Imperial Valley area that is needed in order to meet California's requirement that 33% of utility resource portfolios come from renewable generation by 2020. The capital costs of the Imperial Valley Element were estimated to be \$50 million or less. Consistent with Section 24.4.10 of the CAISO Tariff, CAISO management approved the Imperial Valley Element and conducted an accelerated competitive solicitation during early 2013. On July 11, 2013, the CAISO issued a report that identified IID as the project sponsor for the Imperial Valley element.⁶ IID was the first entity selected to be a project sponsor by the CAISO in a phase 3 competitive solicitation process.⁷

Following the release of the Imperial Valley Element selection report, the CAISO determined that there was a need for an agreement between IID⁸ and the CAISO to identify roles, responsibilities and obligations associated with construction, testing, and ownership of the transmission project during the period prior to the time IID would turn the project over to CAISO operational control. This agreement became known as the "Approved Project Sponsor Agreement" or "IID APSA" or "APSA". As the APSA negotiations with IID moved forward, the CAISO concurrently was in the process of conducting competitive solicitations for the Gates-Gregg and the Sycamore-Penasquitos transmission solutions during 2013 and early 2014.⁹ The CAISO has selected approved project sponsors for both of these transmission elements, and completed APSA negotiations for the Gates-Gregg project. Negotiations are currently underway for the Sycamore-Penasquitos project.

During the same time period, the CAISO conducted a stakeholder process to consider enhancements to its competitive solicitation process.¹⁰ In this process, the CAISO discussed with its stakeholders the need for an APSA and the requirement that

⁴ CAISO tariff § 24.4.10.

⁵ CAISO tariff § 24.5 and subparagraphs.

⁶ http://www.caiso.com/Documents/ImperialValleyPolicyElement-ProjectSponsorSelectionReport_Jul11_2013.pdf.

⁷ The phase 3 competitive solicitation process was part of the CAISO's revised transmission planning process that went into effect with the 2010-2011 planning cycle. However, there were no transmission elements eligible for competitive solicitation until the 2012-2013 cycle.

⁸ There will also be a need for an agreement between the CAISO and approved project sponsors with respect to future transmission solutions awarded through the competitive solicitation process.

⁹ The Gates-Gregg comparative selection report was issued on November 6, 2013 and the Sycamore-Penasquitos comparative selection report was issued on March 4, 2014.

¹⁰ See *Cal. Indep. Sys. Operator Corp.*, 146 FERC ¶ 61,237 (2014).

all approved project sponsors (whether participating transmission owners or not) would be required to enter into such an agreement. The CAISO proposed tariff language directing approved project sponsors to enter into an APSA within 120 days of selection, and the Commission accepted the proposed amendment.¹¹ In response to stakeholder requests, the CAISO also agreed to develop with stakeholders a *pro forma* APSA. This process was initiated in March 2014 when the CAISO posted a draft *pro forma* agreement and sought stakeholder comment. Based on comments received, the CAISO has recently posted a revised draft of the *pro forma* agreement.¹² The ISO intends to file the *pro forma* APSA with the Commission in June 2014.

Because the 2012-2013 competitive selection process preceded the on-going development of the *pro forma* APSA, and because of the need to move forward with projects that have already been approved, the CAISO is filing for Commission approval the instant IID APSA and will be filing individually-negotiated APSAs for the Gates-Gregg and the Sycamore-Penasquitos projects. The Gates-Gregg and Sycamore-Penasquitos APSAs will use the IID APSA, as described in the next sections, as a template.

II. The Approved Project Sponsor Agreement

A. The APSA Governs the Relationship between the Approved Project Sponsor and the CAISO before the Transmission Facilities are Turned over to CAISO Operational Control.

The CAISO tariff contains a high level structure for selecting an approved project sponsor and for the selected sponsor to interact with the CAISO during the project construction and testing period. However, because details about project construction and network interconnection vary according to the project, they must be included in an agreement similar to a large generator interconnection agreement. Furthermore, an agreement is necessary because approved project sponsors who are not participating transmission owners are not subject to the CAISO tariff until such time as they enter into the transmission control agreement, complete project construction and energization, and turn the facilities over to CAISO operational control. For both non-participating transmission owners and participating transmission owners, the APSA “bridges the gap” until such time as the tariff and the transmission control agreement govern the project and the approved project sponsor’s relationship with the CAISO.

This interaction between the CAISO tariff, the transmission control agreement and the IID APSA is described in Article 3. The approved project sponsor agrees to comply with all applicable tariff provisions and the terms of the IID APSA to the extent that they do not conflict with the tariff, to become a participating transmission owner,

¹¹ *Id.* ¶ 16.

¹² http://www.caiso.com/Documents/Proposed-DraftProFormaApprovedProjectSponsorAgreement-May7_2014.doc

and to enter into the transmission control agreement.¹³ Section 3.5 provides that once the obligations set forth in the IID APSA have been completed, the IID APSA will terminate, with certain exceptions. The obligations that continue under the IID APSA after the transmission elements are turned over to CAISO operational control include a requirement in Section 5.3.8 that the approved project sponsor provide final design information and other specifications within 120 days after the project has been turned over to CAISO operational control, a requirement to provide the final cost information to the CAISO within 12 months of turning the project over to CAISO operational control, in accordance with Section 5.2.7, and a requirement that the approved project sponsor abide by any agreed-upon cost containment measures.

Article 4 describes the approved project sponsor's obligation to seek interconnection service from the participating transmission owner if applicable. The approved project sponsor also agrees that the participating transmission owner's handbook will govern certain interconnection requirements. Testing by both the approved project sponsor and the interconnecting participating transmission owner is covered in Article 6.

B. The IID APSA Contains Project Details, Construction Milestones and a Communications Framework.

IID APSA Article 5 contains the CAISO tariff section 24.6.1-24.6.4 requirements that the approved project sponsor provide a detailed construction plan within 120 days from project sponsor selection and, every 90 days until the project is energized, the approved project sponsor is required to provide construction status reports. Article 5 also provides dates upon which project specifications must be provided prior to testing and that these specifications must be compatible with interconnection participating transmission owner specifications. The article provides details regarding the notice and consultation with participating transmission owner process to be followed by the CAISO if the project encounters delay, particularly delays that could impact reliability if the project implementation date is delayed beyond the identified need date.¹⁴ Similarly, project design changes must comply with specific notice and approval requirements.¹⁵

Article 5 contains a specific provision in which the approved project sponsor agrees to abide by cost estimates and cost cap containment feature, if any, set forth in Appendix E to the agreement.¹⁶ This provision is intended to obligate approved project sponsors to meet cost containment features described in the project sponsor application.

¹³ APSA Sections 3.2 and 3.3.

¹⁴ See, e.g. Section 5.5 and 5.6.

¹⁵ See Section 5.11.

¹⁶ See Section 5.2.6.

Section 5.12 provides details for the transition of generator interconnection requests to the project from IID to CAISO procedures once the facilities are turned over to CAISO operational control. In the case of the Imperial Valley Element, there is currently one generator in the IID queue that is requesting interconnection to the Liebert Switching Station.¹⁷ IID will continue to study the generator interconnection request until the station is turned over to CAISO operational control along with the other facilities, and the CAISO will study the proposed generator interconnection request as an affected system. Any network upgrades or additions identified by either the CAISO or IID will be the responsibility of the generator requesting interconnection that causes the need for the upgrades or additions.

Finally, in Section 5.13 the parties recognize and agree that the CAISO is the planning authority for the transmission facilities identified in the IID APSA from the time these facilities are identified in the transmission planning process through construction and energization. This section provides clarity for non-participating transmission owners who are approved project sponsors, particularly those, such as IID, who own other facilities in neighboring planning regions.

Article 6 of the IID APSA governs facility testing by both the approved project sponsor and the participating transmission owner to whose facilities that project will be connected. Because the IID APSA is a two party agreement, the approved project sponsor must provide written approval from the interconnecting participating transmission owner before parallel operations can begin. The CAISO must also approve these arrangements, and this approval will not be unreasonably withheld.¹⁸

IID APSA Article 7 covers metering responsibilities between the CAISO and the approved project sponsor, which are required if the project extends the CAISO's balancing authority area. Article 8 outlines communication requirements between the CAISO, the approved project sponsor and the interconnecting transmission owner. Start-up obligations are covered under Article 9.

C. IID, As an Approved Project Sponsor, Has Transmission Revenue Requirement Rights and Obligations, Under the APSA.

The IID APSA also provides, in Article 11, that the approved project sponsor may seek Commission approval of a transmission revenue requirement while the transmission facilities are not yet operational. If approved, the CAISO will collect that revenue requirement through the regional access charge. Importantly, the approved project sponsor, whether or not subject to Commission rate jurisdiction, agrees to abide by the CAISO tariff with regard to all refunds, transmission revenue requirement adjustments, and other transmission owner tariff adjustments. Such adjustments would

¹⁷ The northern terminus of the IID transmission element.

¹⁸ See Section 6.1.

include payments over- or under-collected during periods prior to project completion, even if the approved project sponsor later abandons the project.¹⁹

III. Implementation of the IID Approved Project Sponsor Agreement

Once the IID transmission element is energized and turned over to CAISO operational control, an existing generator that is currently in commercial operation and interconnected to the Imperial Valley Substation will be moved to the new CAISO Liebert Switching Station. Currently the generator has a three-party large generator interconnection agreement that has been executed by the generator, San Diego Gas & Electric Company and the CAISO. The parties to the contract and IID have been in communication about this issue and intend that, once the point of interconnection changes, the interconnection agreement will be reformed as a three-party interconnection agreement with the generator, IID and the CAISO. The CAISO is currently working with the three other parties to determine the actual transition mechanism. Regardless of the mechanism, the generator will not lose its right to reimbursement of up-front financed costs for network upgrades.

IV. Effective Date

The CAISO requests that the IID APSA be made effective on July 23, 2014. Because IID and the CAISO expect the Imperial Valley project to be energized and turned over to CAISO operational control in May, 2015, the parties are working cooperatively together under the terms of the IID APSA so that the target completion date can be achieved.

V. Service

The CAISO has served copies of this filing upon all parties to Docket No. ER14-1206-000, the California Public Utilities Commission, and the California Energy Commission. The CAISO has also posted the filing on the CAISO website.

Enclosed for filing is each of the following:

- (1) This letter of transmittal; and
- (2) Approved Project Sponsor Agreement (Attachment A).

¹⁹ See Section 11.3.

VI. Correspondence

The CAISO requests that all correspondence, pleadings, and other communications concerning this filing be served upon the following:

Judith B. Sanders*
Senior Counsel
California Independent System
Operator Corporation
250 Outcropping Way
Folsom, CA 95630
Tel: (916) 608-7143
E-mail: jsanders@caiso.com

* Individual designated for service pursuant to Rule 203(b)(3),
18 C.F.R. § 203(b)(3).

VII. Conclusion

The CAISO respectfully requests that the Commission accept this filing and permit the APSA to be effective July 23, 2014. If there are any questions concerning this filing, please contact the undersigned.

Respectfully submitted,

By: /s/ Judith Sanders

Roger Collanton
General Counsel
Anna McKenna
Assistant General Counsel
Judith B. Anders
Senior Counsel
California Independent System
Operator Corporation
250 Outcropping Way
Folsom, CA 95630
Tel: (916) 608-7182
Fax: (916) 608-7222
jsanders@caiso.com
Attorneys for the California Independent
System Operator Corporation

Attachment A – Approved Project Sponsor Agreement

California Independent System Operator Corporation

May 23, 2014

APPROVED PROJECT SPONSOR AGREEMENT (APSA)

BETWEEN

IMPERIAL IRRIGATION DISTRICT

AND

**CALIFORNIA INDEPENDENT SYSTEM OPERATOR
CORPORATION**

PROJECT: IMPERIAL VALLEY ELEMENT

TABLE OF CONTENTS

| | |
|---|----|
| ARTICLE 1. DEFINITIONS | 1 |
| ARTICLE 2. EFFECTIVE DATE, TERM AND TERMINATION..... | 5 |
| ARTICLE 3. REGULATORY FILINGS AND CAISO TARIFF COMPLIANCE | 6 |
| ARTICLE 4. SCOPE OF SERVICE | 7 |
| ARTICLE 5. FACILITIES ENGINEERING, PROCUREMENT, AND CONSTRUCTION | 7 |
| ARTICLE 6. TESTING AND INSPECTION | 13 |
| ARTICLE 7. METERING | 14 |
| ARTICLE 8. COMMUNICATIONS..... | 14 |
| ARTICLE 9. OPERATIONS..... | 15 |
| ARTICLE 10. PERFORMANCE OBLIGATION..... | 15 |
| ARTICLE 11. BILLING AND PAYMENT..... | 16 |
| ARTICLE 12. REGULATORY REQUIREMENTS AND GOVERNING LAWS | 16 |
| ARTICLE 13. NOTICES | 17 |
| ARTICLE 14. FORCE MAJEURE..... | 18 |
| ARTICLE 15. DEFAULT..... | 18 |
| ARTICLE 16. INDEMNITY AND CONSEQUENTIAL DAMAGES..... | 19 |
| ARTICLE 17. ASSIGNMENT..... | 20 |
| ARTICLE 18. SEVERABILITY..... | 21 |
| ARTICLE 19. COMPARABILITY | 21 |
| ARTICLE 20. CONFIDENTIALITY | 21 |
| ARTICLE 21. ENVIRONMENTAL RELEASES..... | 24 |
| ARTICLE 22. INFORMATION ACCESS AND AUDIT RIGHTS..... | 24 |
| ARTICLE 23. SUBCONTRACTORS | 26 |
| ARTICLE 24. DISPUTES | 26 |
| ARTICLE 25. REPRESENTATIONS, WARRANTIES AND COVENANTS | 27 |
| ARTICLE 26. MISCELLANEOUS..... | 29 |

APPENDICES

- Appendix A Interconnection Facilities, Network Upgrades and Distribution Upgrades
- Appendix B Milestones
- Appendix C Security Arrangements Details
- Appendix D Addresses for Delivery of Notices and Billings
- Appendix E Approved Project Sponsor's Costs of Project

APPROVED PROJECT SPONSOR AGREEMENT**IMPERIAL IRRIGATION DISTRICT****CALIFORNIA INDEPENDENT SYSTEM OPERATOR CORPORATION**

THIS APPROVED PROJECT SPONSOR AGREEMENT ("APSA") is made and entered into this 10 day of MARCH, 2014, between the Imperial Irrigation District, organized and existing under the laws of the State of California ("Approved Project Sponsor") and the California Independent System Operator Corporation, a California nonprofit public benefit corporation organized and existing under the laws of the State of California ("CAISO"). Approved Project Sponsor and CAISO each may be referred to as a "Party" or collectively as the "Parties."

RECITALS

WHEREAS, CAISO exercises Operational Control over the CAISO Controlled Grid; and

WHEREAS, Approved Project Sponsor intends to construct, finance and own the Imperial Valley Element Project ("Project") consisting of transmission additions or upgrades identified in Appendix A to this APSA; and

WHEREAS, the Parties agree that, upon energization of the Project, Approved Project Sponsor will enter into the Transmission Control Agreement to become a Participating Transmission Owner ("Participating TO") and will turn the Project over to the Operational Control of the CAISO; and

WHEREAS, the Parties recognize that the Approved Project Sponsor has certain rights and obligations related to the Project that arise prior to the date upon which the Approved Project Sponsor becomes a Participating TO and which may remain in effect for a discrete period of time after the Approved Project Sponsor enters into the Transmission Control Agreement; and

WHEREAS, Approved Project Sponsor and CAISO thus have agreed to enter into this APSA for the purpose of identifying rights and obligations associated with the Project that arise prior to the effective date of the Transmission Control Agreement;

NOW, THEREFORE, in consideration of and subject to the mutual covenants contained herein, it is agreed:

ARTICLE 1. DEFINITIONS

When used in this APSA, terms with initial capitalization that are not defined in this Article 1 shall have the meanings specified in the Article in which they are used.

Affiliate shall mean, with respect to a corporation, partnership or other entity, each such other corporation, partnership or other entity that directly or indirectly, through one or more intermediaries, controls, is controlled by, or is under common control with, such corporation, partnership or other entity.

Applicable Laws and Regulations shall mean all duly promulgated applicable federal, state and local laws, regulations, rules, ordinances, codes, decrees, judgments, directives, or judicial or administrative orders, permits and other duly authorized actions of any Governmental Authority.

Applicable Reliability Council shall mean the Western Electricity Coordinating Council or its successor.

Applicable Reliability Standards shall mean the requirements and guidelines of NERC, the Applicable Reliability Council, and the Balancing Authority Area of the Participating TO's Transmission System to which the Project is directly connected, including requirements adopted pursuant to Section 215 of the Federal Power Act.

Balancing Authority shall mean the responsible entity that integrates resource plans ahead of time, maintains load-interchange-generation balance within a Balancing Authority Area, and supports Interconnection frequency in real time.

Balancing Authority Area shall mean the collection of generation, transmission, and loads within the metered boundaries of the Balancing Authority. The Balancing Authority maintains load-resource balance within this area.

Breach shall mean the failure of a Party to perform or observe any material term or condition of this APSA.

Breaching Party shall mean a Party that is in Breach of this APSA.

Business Day shall mean Monday through Friday, excluding federal holidays and the day after Thanksgiving Day.

CAISO Controlled Grid shall mean the system of transmission lines and associated facilities of the parties to the Transmission Control Agreement that have been placed under the CAISO's Operational Control.

CAISO Tariff shall mean the CAISO's tariff, as filed with FERC, and as amended or supplemented from time to time, or any successor tariff.

Calendar Day shall mean any day including Saturday, Sunday or a federal holiday.

Commercial Operation Date of the Project shall mean the date on which the Project commences Commercial Operation as agreed to by the applicable Participating TO, the CAISO, and the Approved Project Sponsor in writing.

Confidential Information shall mean any confidential, proprietary or trade secret information of a plan, specification, pattern, procedure, design, device, list, concept, policy or compilation relating to the present or planned business of a Party, which is designated as confidential by the Party supplying the information, whether conveyed orally, electronically, in writing, through inspection, or otherwise, subject to Article 20.

Default shall mean the failure of a Breaching Party to cure its Breach in accordance with Article 15 of this APSA.

Effective Date shall mean the date on which this APSA becomes effective upon execution by all Parties subject to acceptance by FERC, or if filed unexecuted, upon the date specified by FERC.

Environmental Law shall mean Applicable Laws or Regulations relating to pollution or protection of the environment or natural resources.

Federal Power Act shall mean the Federal Power Act, as amended, 16 U.S.C. §§ 791a et seq.

FERC shall mean the Federal Energy Regulatory Commission or its successor.

Force Majeure shall mean any act of God, labor disturbance, act of the public enemy, war, insurrection, riot, fire, storm or flood, earthquake, explosion, breakage or accident to machinery or equipment, any order, regulation or restriction imposed by governmental, military or lawfully established civilian authorities, or any other cause beyond a Party's control. A Force Majeure event does not include acts of negligence or intentional wrongdoing by the Party claiming Force Majeure.

Good Utility Practice shall mean any of the practices, methods and acts engaged in or approved by a significant portion of the electric utility industry during the relevant time period, or any of the practices, methods and acts which, in the exercise of reasonable judgment in light of the facts known at the time the decision was made, could have been expected to accomplish the desired result at a reasonable cost consistent with good business practices, reliability, safety and expedition. Good Utility Practice is not intended to be any one of a number of the optimum practices, methods, or acts to the exclusion of all others, but rather to be acceptable practices, methods, or acts generally accepted in the region.

Governmental Authority shall mean any federal, state, local or other governmental, regulatory or administrative agency, court, commission, department, board, or other governmental subdivision, legislature, rulemaking board, tribunal, or other governmental authority having jurisdiction over the Parties, their respective

facilities, or the respective services they provide, and exercising or entitled to exercise any administrative, executive, police, or taxing authority or power; provided, however, that such term does not include the Approved Project Sponsor, CAISO, , or any Affiliate thereof.

Hazardous Substances shall mean any chemicals, materials or substances defined as or included in the definition of “hazardous substances,” “hazardous wastes,” “hazardous materials,” “hazardous constituents,” “restricted hazardous materials,” “extremely hazardous substances,” “toxic substances,” “radioactive substances,” “contaminants,” “pollutants,” “toxic pollutants” or words of similar meaning and regulatory effect under any applicable Environmental Law, or any other chemical, material or substance, exposure to which is prohibited, limited or regulated by any applicable Environmental Law.

Interconnection Facilities shall mean the Participating TO’s Interconnection Facilities and the Approved Project Sponsor’s Interconnection Facilities. Collectively, Interconnection Facilities include all facilities and equipment between the Project and the Point of Interconnection, including any modification, additions or upgrades that are necessary to physically and electrically interconnect the Project to the Participating TO’s Transmission System. Interconnection Facilities are sole use facilities and shall not include Distribution Upgrades, or Network Upgrades.

Interconnection Handbook shall mean a handbook, developed by the Participating TO and posted on the Participating TO’s web site or otherwise made available by the Participating TO, describing technical and operational requirements for wholesale generators and loads connected to the Participating TO’s portion of the CAISO Controlled Grid, as such handbook may be modified or superseded from time to time. Participating TO’s standards contained in the Interconnection Handbook shall be deemed consistent with Good Utility Practice and Applicable Reliability Standards. In the event of a conflict between the terms of this APSA and the terms of the Participating TO’s Interconnection Handbook, the terms in this APSA shall apply.

Interconnection Service shall mean the service defined in Article 4.2 of this Agreement.

Loss shall mean any and all damages, losses, and claims, including claims and actions relating to injury to or death of any person or damage to property, demand, suits, recoveries, costs and expenses, court costs, attorney fees, and all other obligations by or to third parties.

Metering Equipment shall mean all metering equipment installed or to be installed for measuring the Balancing Authority Area boundary pursuant to this APSA at the metering points, including but not limited to instrument transformers, MWh-meters, data acquisition equipment, transducers, remote terminal unit, communications equipment, phone lines, and fiber optics.

NERC shall mean the North American Electric Reliability Corporation or its successor organization.

Operational Control shall mean the rights of the CAISO under the Transmission Control Agreement and the CAISO Tariff to direct the parties to the Transmission Control Agreement how to operate their transmission lines and facilities and other electric plant affecting the reliability of those lines and facilities for the purpose of affording comparable non-discriminatory transmission access and meeting applicable reliability criteria.

Party or Parties shall mean the CAISO, Approved Project Sponsor or the applicable combination of the above.

Project shall mean the transmission additions or upgrades the Approved Project Sponsor has agreed to construct, finance and own pursuant to this Agreement.

Point of Interconnection shall mean the point, as set forth in Appendix A to this APSA, where the Interconnection Facilities connect to the Participating TO's Transmission System.

Reasonable Efforts shall mean, with respect to an action required to be attempted or taken by a Party under this APSA, efforts that are timely and consistent with Good Utility Practice and are otherwise substantially equivalent to those a Party would use to protect its own interests.

System Protection Facilities shall mean the equipment, including necessary protection signal communications equipment, that protects (1) the Participating TO's Transmission System, Participating TO's Interconnection Facilities, CAISO Controlled Grid, and Affected Systems from faults or other electrical disturbances and (2) the Approved Project Sponsor's Transmission System from faults or other electrical system disturbances occurring on the CAISO Controlled Grid, Participating TO's Interconnection Facilities, and Affected Systems or on other delivery systems or other generating systems to which the CAISO Controlled Grid is directly connected.

Transmission Control Agreement shall mean CAISO FERC Electric Tariff No. 7.

ARTICLE 2. EFFECTIVE DATE, TERM AND TERMINATION

2.1 Effective Date. This APSA shall become effective upon execution by all Parties subject to acceptance by FERC (if applicable) or, if filed unexecuted, upon the date specified by FERC. The CAISO shall promptly file this APSA with FERC upon execution in accordance with Article 3.1, if required.

2.2 Term of Agreement. Subject to the provisions of Article 2.3, this APSA shall remain in effect until all terms and condition of this Agreement have been fulfilled or default by the Approved Project Sponsor.

2.3 Termination Procedures.

2.3.1 Written Notice. This APSA may be terminated by the Approved Project Sponsor after giving the CAISO ninety (90) Calendar Days advance written notice, or by the CAISO notifying FERC after the transmission additions or upgrades have been turned over to CAISO Operational Control.

2.3.2 Default. A Party may terminate this APSA in accordance with Article 15.

2.3.3 Notwithstanding Articles 2.3.1 and 2.3.2, no termination shall become effective until the Parties have complied with all Applicable Laws and Regulations applicable to such termination and if applicable, FERC has accepted the notice of termination.

ARTICLE 3. REGULATORY FILINGS AND CAISO TARIFF COMPLIANCE

3.1 Filing. The CAISO shall file this APSA (and any amendment hereto) with the appropriate Governmental Authority(ies), if required. The Approved Project Sponsor may request that any information so provided be subject to the confidentiality provisions of Article 20. If the Approved Project Sponsor has executed this APSA, or any amendment thereto, the Approved Project Sponsor shall reasonably cooperate with CAISO with respect to such filing and to provide any information reasonably requested by CAISO needed to comply with applicable regulatory requirements.

3.2 Agreement Subject to CAISO Tariff. The Approved Project Sponsor will comply with all applicable provisions of the CAISO Tariff.

3.3 Relationship Between this APSA and the CAISO Tariff. With regard to rights and obligations between the Approved Project Sponsor, if and to the extent a matter is specifically addressed by a provision of this APSA (including any appendices, schedules or other attachments to this APSA), the provisions of this APSA shall govern. If and to the extent a provision of this APSA is inconsistent with the CAISO Tariff and dictates rights and obligations between the CAISO and the Approved Project Sponsor, the CAISO Tariff shall govern.

3.4 Requirement to Become a Participating TO. The Approved Project Sponsor agrees that the Project will be under CAISO Operational Control, and the Approved Project Sponsor further agrees that it will meet the CAISO Tariff requirements to become a Participating TO in accordance with Section 4.3 of the CAISO Tariff.

3.5 Relationship Between this APSA and the Transmission Control Agreement.

Once the Approved Project Sponsor has entered into the Transmission Control Agreement, if and to the extent a matter specifically addressed in this APSA is inconsistent with the Transmission Control Agreement, the terms of the Transmission Control Agreement shall govern. Once the rights and obligations under the APSA are completed, the APSA terminates and the Transmission Control Agreement will govern the rights and responsibilities of the Approved Project Sponsor as a Participating Transmission Owner.

ARTICLE 4. SCOPE OF SERVICE

4.1 Transmission Additions or Upgrades. The Approved Project Sponsor shall build and connect to the CAISO Controlled Grid the Project identified in Appendix A.

4.2 Interconnection Service. Interconnection Service allows the Approved Project Sponsor to connect the Project to the CAISO Controlled Grid. If applicable, the Approved Project Sponsor separately must seek Interconnection Service from the Participating TO to whose facilities the project will interconnect.

4.3 Approved Project Sponsor to Meet Requirements of the Participating TO's Interconnection Handbook. If applicable, the Approved Project Sponsor shall comply with the Participating TO's Interconnection Handbook.

4.4 Performance Standards. Each Party shall perform all of its obligations under this APSA in accordance with Applicable Laws and Regulations, Applicable Reliability Standards, and Good Utility Practice, and to the extent a Party is required or prevented or limited in taking any action by such regulations and standards, such Party shall not be deemed to be in Breach of this APSA for its compliance therewith. If such Party is the CAISO, then the CAISO shall amend the APSA and submit the amendment to FERC for approval.

ARTICLE 5. FACILITIES ENGINEERING, PROCUREMENT, AND CONSTRUCTION

5.1 General. Interconnection Facilities and Network Upgrades described in this APSA shall be constructed pursuant to Good Utility Practice and shall be based on the assumed accuracy and completeness of all technical information received by the CAISO from the Approved Project Sponsor. Changes to the Interconnection Facilities and Network Upgrades described in this APSA must be approved by the CAISO in accordance with Article 5.11 of this Agreement. Unless otherwise mutually agreed among the Parties, the Approved Project Sponsor shall select the testing date, and the energization date for the Project shall be consistent with the application approved by the CAISO, and such dates shall be set forth in Appendix B, Milestones.

- 5.2 Conditions Applicable.** The Approved Project Sponsor shall comply with all requirements of law and assumes responsibility for the design, procurement and construction of the Project using Good Utility Practice and the standards and specifications provided by the Participating TO that the Project is interconnected to, if applicable.
- 5.2.1** The CAISO may, at its option, review the engineering design, equipment acceptance tests, and the construction of the Project;
- 5.2.2** Prior to commencement of construction, the Approved Project Sponsor shall provide to the CAISO for informational purposes, a schedule for construction of the Participating TO's Interconnection Facilities;
- 5.2.3** At any time during construction, should any phase of the engineering, equipment procurement, or construction of the Project not meet the standards and specifications provided by the Participating TO, the Approved Project Sponsor shall be obligated to remedy deficiencies in that portion of the Project;
- 5.2.4** The Approved Project Sponsor shall indemnify the CAISO for claims arising from the Approved Project Sponsor's construction of the Project under the terms and procedures applicable to Article 16.1 Indemnity;
- 5.2.5** The Approved Project Sponsor shall transfer Operational Control of the Project to the CAISO upon completion of the Project;
- 5.2.6** The Approved Project Sponsor agrees with the cost estimates and the binding cost cap, if applicable, included in Appendix E. The cost cap will be adjusted to accommodate Force Majeure events addressed in Article 14.
- 5.2.7** As soon as reasonably practicable, but within twelve months after completion of the construction of the Project, the Approved Project Sponsor shall provide summary of the final cost of the construction of the Project, which summary shall set forth such costs in sufficient detail to enable the CAISO to understand the cost of the Project, including use of contingency and any cost overruns; and
- 5.2.8** The Approved Project Sponsor shall deliver to the CAISO "as-built" drawings, information, and any other documents that are reasonably required by the CAISO to assure that the Project is built to the standards and specifications required by the Participating TO.
- 5.3 Construction Commencement.** The Approved Project Sponsor shall commence construction of the Project for which it is responsible as soon as practicable after the following additional conditions are satisfied by each party:

- 5.3.1** Approval of the appropriate Governmental Authority has been obtained for any facilities requiring regulatory approval; and
- 5.3.2** Necessary real property rights and rights-of-way have been obtained, to the extent required for the construction of the Project.
- 5.4 Work Progress.** The Approved Project Sponsor will keep the CAISO advised monthly as to the progress of the financing, procurement and construction efforts, which can be via email or verbal discussion as agreed upon by the parties.
- 5.4.1** The Approved Project Sponsor shall provide the CAISO with the Initial Construction Plan one hundred twenty (120) Calendar Days after the Approved Project Sponsor has been selected. The plan shall include: Land acquisition and permits requirements, status and schedule; materials procurement requirements, status and schedule; construction financing status and schedule; and Project contacts, if different than selection process.
- 5.4.2** Every ninety (90) Calendar Days after the Initial Construction Plan is received until the Project is energized and under CAISO Operational Control, the Approved Project Sponsor shall provide the CAISO with a Construction Plan Status Report which shall include, but is not limited to Project schedule; Permit and license status – environmental, state, local; Right-of-way status; Land acquisition status; Design and engineering status; concern with or change in ability to meet design specifications; status of contracts for project work, including land, procurement, staffing; Participating TO interconnection agreement status; construction status; testing status; risks and obstacles; and Project budget including actuals, estimate to complete, contingency. The format for the report will be in accordance with the Business Practice Manual on Transmission Planning Process.
- 5.4.3** The CAISO will send Project status reports received in accordance with Section 5.4.2 to the applicable Participating TO(s) and then the CAISO will hold a call with the Participating TO(s) to review the status report, including completion date and items of concern.
- 5.4.4** Every ninety (90) calendar days until the Project is energized and under CAISO Operational Control, the Participating TO shall provide the CAISO with an Interconnection Facilities Status Report which shall include, but is not limited to project schedule; permit and license status – environmental, state, local; right-of-way status, if required; land acquisition status, if required; design and engineering status; status of contracts for project work, including land, procurement, staffing; construction status; testing status; risks and obstacles; and project budget including actuals, estimate

to complete, contingency. The format for the report will be in accordance with Business Practice Manual for Transmission Planning Process.

- 5.4.5** If, at any time, the Approved Project Sponsor determines that the completion of the Participating TO's Interconnection Facilities will not be required until after the specified energization date, the Approved Project Sponsor will provide written notice to the Participating TO and CAISO of such later date upon which the completion of the Participating TO's Interconnection Facilities will be required.
- 5.5 Delay in Project.** If CAISO has received notification from the Approved Project Sponsor of delay in Project energization beyond the date upon which the project was found to be needed, the CAISO shall issue a market notice to market participants stating that the Project is delayed and that, if applicable, a plan is being developed to address potential NERC reliability standard violations as set forth in Section 24.6.3 of the CAISO Tariff as well as any material concerns.
- 5.5.1** The CAISO shall determine if there is a potential NERC violation, for either the CAISO or applicable Participating TO(s), arising from any Project energization delay and will determine if there are other material issues of concern. If there are potential violations or material issues, the CAISO, Approved Project Sponsor and applicable Participating TO(s) shall develop a plan to address the delay. The plan may include directing the Participating TO to develop a mitigation plan.
- 5.5.2** If violations or material issues cannot be promptly and adequately addressed, CAISO will take action to resolve the issues, including determining if an alternate project sponsor is required.
- 5.6 Delay in Approvals, Property Acquisition or Construction.** If unreasonable delays in necessary Project approvals, acquisition of any and all real property rights, including but not limited to fee title, right of way grant, easement and license rights essential for construction of the Project or construction timelines, as set forth in Appendix B (Milestones) occur, the CAISO shall consult with the Approved Project Sponsor. If, following such consultation, (a) the CAISO determines that (i) the Approved Project Sponsor cannot secure necessary approvals or property rights or is otherwise unable to construct the Project; or (ii) an alternative Project Sponsor is necessary pursuant to Section 24.6.2 of the CAISO Tariff; or, (b) the Approved Project Sponsor determines that it is unable to proceed with construction and so notifies the CAISO, then CAISO shall take such actions that it determines are appropriate and necessary, including termination of this agreement. If either Party determines that a new Approved Project Sponsor should be selected, the Approved Project Sponsor agrees to work with CAISO, the new Approved Project Sponsor, and, if applicable, the Participating TO to transfer responsibility for the Project to the new Approved Project Sponsor.

- 5.7 Information Exchange.** As soon as reasonably practicable after the Effective Date, the Approved Project Sponsor shall provide information to the CAISO regarding the design and compatibility of the Approved Project Sponsor's Project and Participating TO's Interconnection Facilities and compatibility of the Interconnection Facilities with the Approved Project Sponsor's Project, and shall work diligently and in good faith to make any necessary design changes to the description of the Project set forth in Appendix A.
- 5.8 Approved Project Sponsor's Project.** The Approved Project Sponsor shall, at its expense, design, procure, construct, own and install the Project, as set forth in Appendix A.
- 5.8.1 Approved Project Sponsor's Project Specifications.** The Approved Project Sponsor shall submit necessary specifications for the Project, including System Protection Facilities, to the CAISO at least one hundred eighty (180) Calendar Days prior to the date that testing will commence and final specifications for review and comment at least ninety (90) Calendar Days prior to the date that testing will commence. The CAISO shall review such specifications to ensure that the Project is compatible with the technical specifications, operational control, safety requirements, and any other applicable requirements of the Participating TO and the CAISO and will provide any comments on such specifications within thirty (30) Calendar Days of the Approved Project Sponsor's submission. All specifications provided hereunder shall be deemed confidential.
- 5.8.2 Participating TO's and CAISO's Review.** The Participating TO's and the CAISO's review of the Approved Project Sponsor's final specifications shall not be construed as confirming, endorsing, or providing a warranty as to the design, fitness, safety, durability or reliability of the Project or the Participating TO's Interconnection Facilities, if applicable. As described in Section 5.8 above, Approved Project Sponsor shall make such changes to the Approved Project Sponsor's Project as may reasonably be required by the Participating TO or the CAISO, in accordance with Good Utility Practice, to ensure that the Approved Project Sponsor's Project are compatible with the technical specifications, Operational Control, and safety requirements of the Participating TO or the CAISO.
- 5.8.3 Approved Project Sponsor's Project Construction.** The Approved Project Sponsor's Project shall be designed and constructed in accordance with Good Utility Practice. Within one hundred twenty (120) Calendar Days after the Project has been turned over to CAISO Operational Control, unless the CAISO and Approved Project Sponsor agree on another mutually acceptable deadline, the Approved Project Sponsor shall deliver to the Participating TO and CAISO "as-built" drawings, information and documents for the Approved Project Sponsor's Project, including, as applicable, a one-line diagram, a site plan drawing

showing the Approved Project Sponsor's Project including Interconnection Facilities, plan and elevation drawings showing the layout of the Approved Project Sponsor's Interconnection Facilities, a relay functional diagram, relaying AC and DC schematic wiring diagrams and relay settings for all facilities associated with the Approved Project Sponsor's Project, and, if applicable, the impedances (determined by factory tests) for the associated transformers. The Approved Project Sponsor shall provide the Participating TO and the CAISO specifications for the protection settings, transformer tap settings, and communications, if applicable. Any deviations from the relay settings, machine specifications, and other specifications originally submitted by the Approved Project Sponsor shall be assessed by the Participating TO and the CAISO pursuant to the appropriate provisions of this APSA.

- 5.9 Permits.** The Approved Project Sponsor shall obtain all permits, licenses and authorization that are necessary to accomplish the Project in compliance with Applicable Laws and Regulations.
- 5.10 Tax Status.** Each Party shall cooperate with the others to maintain the other Parties' tax status. Nothing in this APSA is intended to adversely affect the CAISO's or any Participating TO's tax exempt status with respect to the issuance of bonds including, but not limited to, Local Furnishing Bonds.
- 5.11 Modification.**
- 5.11.1 General.** The Approved Project Sponsor may undertake modifications to its facilities, subject to the approval of the CAISO and the provisions of this APSA and the CAISO Tariff. If the Approved Project Sponsor plans to undertake a modification then it shall provide such information regarding such modification to the CAISO as the CAISO deems necessary to evaluate the potential impact of such modification prior to commencement of the work. Such information shall be deemed to be confidential hereunder and shall include information concerning the timing of such modifications, any technical information and cost impact. The Approved Project Sponsor shall provide the relevant drawings, plans, and specifications to the CAISO at least ninety (90) Calendar Days in advance of the commencement of the work or such shorter period upon which the Parties may agree, which agreement shall not unreasonably be withheld, conditioned or delayed. The CAISO shall approve the modification if it determines that the modification is in accordance with the original Project criteria and intent.
- 5.11.2 Standards.** Any additions, modifications, or replacements made to the Project's facilities shall be designed, constructed and operated in accordance with this APSA and Good Utility Practice.

5.12 Interconnection Study Process.

5.12.1 Existing Study Requests. The Approved Project Sponsor shall complete any existing studies for interconnection to the Project that were in the Approved Project Sponsor's queue upon the effective date of this APSA, and CAISO and the Participating TO will perform studies as an Affected System.

5.12.2 Future Study Requests. Any future interconnection requests submitted to the Approved Project Sponsor for the Project, following the execution date of this APSA, shall be directed to the CAISO Interconnection Queue process. The Approved Project Sponsor will assume the functions of a Participating TO in accordance with Appendix DD of the CAISO Tariff, including performing Phase I, Phase II, and reassessment analysis for generator interconnection requests to the Project. The Approved Project Sponsor will be reimbursed actual costs incurred for the analysis similar to the Participating TOs.

5.12.3 Generator Interconnection Agreements. Any Generator Interconnection Agreements for the Project will be executed consistent with the relevant terms and conditions of CAISO Tariff.

5.13 Planning Authority. The CAISO is the Planning Authority, as that term is defined by NERC, for the Project from the time it is identified in the CAISO's Transmission Planning Process and approved by the CAISO Board of Governors, regardless of the status of Project construction or energization. As such, the Approved Project Sponsor shall be subject to the rights and obligations set forth in CAISO Tariff Section 24 that are applicable to Participating TOs as they pertain to the Project.

ARTICLE 6. TESTING AND INSPECTION

6.1 Pre-Commercial Operation Date Testing and Modifications. Prior to energizing the Project for testing, the Participating TO shall test the Participating TO's Interconnection Facilities and the Approved Project Sponsor shall test the Project to ensure their safe and reliable operation. All testing shall be coordinated and approved by the CAISO to ensure grid reliability. Similar testing may be required after initial operation. Each Party shall make any modifications to its facilities that are found to be necessary as a result of such testing. The Approved Project Sponsor shall bear the cost of all such testing and modifications. The Approved Project Sponsor shall not commence initial parallel operation of the Project until the Participating TO provides prior written approval to the CAISO and Approved Project Sponsor, which approval shall not be unreasonably withheld.

- 6.2 Right to Observe Testing.** The Approved Project Sponsor shall notify the CAISO at least fourteen (14) Calendar Days in advance of its performance of tests. The CAISO has the right, at its own expense, to observe such testing.
- 6.3 Right to Inspect.** The CAISO shall have the right, but shall have no obligation to (i) observe the Approved Project Sponsors' tests and/or inspection of any of its System Protection Facilities and other protective equipment; and (ii) review the settings of the Approved Project Sponsor's System Protection Facilities and other protective equipment. The CAISO may exercise these rights from time to time as it deems necessary upon reasonable notice to the Approved Project Sponsor. The exercise or non-exercise by CAISO of any such rights shall not be construed as an endorsement or confirmation of any element or condition of the Project or the System Protection Facilities or other protective equipment or the operation thereof, or as a warranty as to the fitness, safety, desirability, or reliability of same. Any information that CAISO obtains through the exercise of any of its rights under this Article 6.3 shall be deemed to be Confidential Information and treated pursuant to Article 20 of this APSA.

ARTICLE 7. METERING

- 7.1 General.** The Approved Project Sponsor shall comply with any Applicable Reliability Standards and the Applicable Reliability Council requirements regarding metering. The Approved Project Sponsor and CAISO shall comply with the provisions of the CAISO Tariff regarding metering, including Section 10 of the CAISO Tariff. Power flows to and from the Project shall be measured at or, at the CAISO's option for its respective Metering Equipment, compensated to, the Scheduling Point. The CAISO shall provide metering quantities to the Approved Project Sponsor upon request in accordance with the CAISO Tariff by directly polling the CAISO's meter data acquisition system. The Approved Project Sponsor shall bear all reasonable documented costs associated with the purchase, installation, operation, testing and maintenance of the Metering Equipment.

ARTICLE 8. COMMUNICATIONS

- 8.1 Approved Project Sponsor Obligations.** The Approved Project Sponsor shall maintain satisfactory operating communications with the CAISO in accordance with the provisions of the CAISO Tariff and with the Participating TO's dispatcher or representative designated by the Participating TO. The Approved Project Sponsor shall provide standard voice line, dedicated voice line and facsimile communications at the Project's control room or central dispatch facility through use of either the public telephone system or a voice communications system that does not rely on the public telephone system. The Approved Project Sponsor shall also provide the dedicated data circuit(s) necessary to provide Approved Project Sponsor data to the CAISO and Participating TO as set forth in Appendix C, Security Arrangements Details. The data circuit(s) shall extend from the

Project to the location(s) specified by the CAISO and Participating TO. Any required maintenance of such communications equipment shall be performed by the Approved Project Sponsor. Operational communications shall be activated and maintained under, but not be limited to, the following events: system paralleling or separation, scheduled and unscheduled shutdowns, and equipment clearances.

ARTICLE 9. OPERATIONS

- 9.1 General.** Each Party shall comply with Applicable Reliability Standards and the Applicable Reliability Council operating requirements. Each Party shall provide to the other Party all information that may reasonably be required by the other Party to comply with Applicable Laws and Regulations and Applicable Reliability Standards.
- 9.2 CAISO Obligations.** The CAISO shall cause the Participating TO's Transmission System to be operated and controlled in a safe and reliable manner during testing and synchronization, and before the Approved Project Sponsor turns the Project over to CAISO Operational Control. The CAISO may provide operating instructions to the Approved Project Sponsor consistent with this APSA and Participating TO and CAISO operating protocols and procedures as they may change from time to time. The Participating TO and CAISO will consider changes to their operating protocols and procedures proposed by the Approved Project Sponsor.
- 9.4 Approved Project Sponsor Obligations.** The Approved Project Sponsor shall at its own expense operate, maintain and control the Project in a safe and reliable manner and in accordance with this APSA in advance of turning over Operational Control to the CAISO. Appendix A, Project Details, sets forth applicable requirements of the CAISO Balancing Authority Area and may be modified to reflect changes to the requirements as they may change from time to time. The Approved Project Sponsor shall not energize the Project with the Participating TO's Transmission System until the Participating TO provides prior written approval.
- 9.5 Start-Up and Synchronization.** Consistent with the Parties' mutually acceptable procedures, the Approved Project Sponsor is responsible for the proper energization of the Project to the CAISO Controlled Grid.

ARTICLE 10. PERFORMANCE OBLIGATION

- 10.1 Approved Project Sponsor's Project.** The Approved Project Sponsor shall design, procure, construct, install, own and/or control the Approved Project Sponsor's Project described in Appendix A at its sole expense.

ARTICLE 11. BILLING AND PAYMENT

- 11.1 Transmission Revenue Requirement.** The Approved Project Sponsor may apply to FERC for a Transmission Revenue Requirement for Transmission Facilities not yet in operation, but approved under the transmission planning provisions of the CAISO Tariff, that will be Regional Transmission Facilities or Local Transmission Facilities when placed under the CAISO's Operational Control. If FERC approves such Transmission Revenue Requirement, the CAISO shall incorporate the Transmission Revenue Requirement into the Regional Access Charge or Local Access Charge in accordance with the CAISO Tariff.
- 11.2 Application of CAISO Tariff.** The CAISO and Approved Project Sponsor shall comply with the billing and payment provisions set forth in the CAISO Tariff.
- 11.3 Refund Obligation.** Each Approved Project Sponsor, whether or not it is subject to FERC rate jurisdiction under Section 205 and Section 206 of the Federal Power Act, shall make all refunds, adjustments to its Transmission Revenue Requirement, and adjustments to its Approved Project Sponsor Tariff and do all other things required of a Participating TO to implement any FERC order related to the CAISO Tariff, including any FERC order that requires the CAISO to make payment adjustments or pay refunds to, or receive prior period overpayments from, any Participating TO. All such refunds and adjustments shall be made, and all other actions taken, in accordance with the CAISO Tariff, unless the applicable FERC order requires otherwise.

ARTICLE 12. REGULATORY REQUIREMENTS AND GOVERNING LAWS

- 12.1 Regulatory Requirements.** Each Party's obligations under this APSA shall be subject to its receipt of any required approval or certificate from one or more Governmental Authorities in the form and substance satisfactory to the applying Party, or the Party making any required filings with, or providing notice to, such Governmental Authorities, and the expiration of any time period associated therewith. Each Party shall in good faith seek and use its Reasonable Efforts to obtain such other approvals. Nothing in this APSA shall require the Approved Project Sponsor to take any action that could result in its inability to obtain, or its loss of, status or exemption under the Federal Power Act or the Public Utility Holding Company Act of 1935, as amended, or the Public Utility Regulatory Policies Act of 1978, or the Energy Policy Act of 2005.

12.2 Governing Law.

12.2.1 The validity, interpretation and performance of this APSA and each of its provisions shall be governed by the laws of the state of California [where the Point of Interconnection is located], without regard to its conflicts of law principles.

12.2.2 This APSA is subject to all Applicable Laws and Regulations.

12.2.3 Each Party expressly reserves the right to seek changes in, appeal, or otherwise contest any laws, orders, rules, or regulations of a Governmental Authority.

ARTICLE 13. NOTICES

13.1 General. Unless otherwise provided in this APSA, any notice, demand or request required or permitted to be given by a Party to another and any instrument required or permitted to be tendered or delivered by a Party in writing to another shall be effective when delivered and may be so given, tendered or delivered, by (i) recognized national courier, (ii) depositing the same with the United States Postal Service with postage prepaid for delivery by certified or registered mail, addressed to the Party, or (iii) personal delivery to the Party, at the address set out in Appendix D, Addresses for Delivery of Notices and Billings.

A Party must update the information in Appendix D as information changes. A Party may change the notice information in this APSA by giving five (5) Business Days written notice prior to the effective date of the change. Such changes shall not constitute an amendment to this APSA.

13.2 Alternative Forms of Notice. Any notice or request required or permitted to be given by a Party to another and not required by this APSA to be given in writing may be so given by telephone, facsimile or e-mail to the telephone numbers and e-mail addresses set out in Appendix D.

13.4 Operations Notice. Each Party shall notify the other Parties in writing of the identity of the person(s) that it designates as the point(s) of contact with respect to the implementation of Articles 9 and 10.

13.5 Project Management. If the Approved Project Sponsor desires to change the identified project management, including key personal, the Approved Project Sponsor shall notify the CAISO in writing thirty (30) days in advance for approval. Such approval shall not be unreasonably withheld.

ARTICLE 14. FORCE MAJEURE

14.1 Force Majeure.

14.1.1 Economic hardship is not considered a Force Majeure event.

14.1.2 No Party shall be considered to be in Default with respect to any obligation hereunder, if prevented from fulfilling such obligation by Force Majeure. A Party unable to fulfill any obligation by reason of Force Majeure shall give notice and the full particulars of such Force Majeure to the other Party in writing or by telephone as soon as reasonably possible after the occurrence of the cause relied upon. Telephone notices given pursuant to this Article shall be confirmed in writing as soon as reasonably possible and shall specifically state full particulars of the Force Majeure, the time and date when the Force Majeure occurred and when the Force Majeure is reasonably expected to cease. The Party affected shall exercise due diligence to remove such disability with reasonable dispatch, but shall not be required to accede or agree to any provision not satisfactory to it in order to settle and terminate a strike or other labor disturbance.

ARTICLE 15. DEFAULT

15.1 Default.

15.1.1 General. No Default shall exist where such failure to discharge an obligation (other than the payment of money) is the result of Force Majeure as defined in this APSA or the result of an act or omission of the other Party. Upon a Breach, the affected non-Breaching Party(ies) shall give written notice of such Breach to the Breaching Party. The Breaching Party shall have thirty (30) Calendar Days from receipt of the Default notice within which to cure such Breach; provided however, if such Breach is not capable of cure within thirty (30) Calendar Days, the Breaching Party shall commence such cure within thirty (30) Calendar Days after notice and continuously and diligently complete such cure within ninety (90) Calendar Days from receipt of the Default notice; and, if cured within such time, the Breach specified in such notice shall cease to exist.

15.1.2 Right to Terminate. If a Breach is not cured as provided in this Article, or if a Breach is not capable of being cured within the period provided for herein, the affected non-Breaching Party(ies) shall have the right to declare a Default and terminate this APSA by written notice at any time until cure occurs, and be relieved of any further obligation hereunder and, whether or not such Party(ies) terminates this APSA, to recover from the Breaching Party all amounts due hereunder, plus all other damages and remedies to which it is entitled at law or in equity. The provisions of this Article will survive termination of this APSA.

ARTICLE 16. INDEMNITY AND CONSEQUENTIAL DAMAGES

16.1 Indemnity. Each Party shall at all times indemnify, defend, and hold the other Parties harmless from, any and all Losses arising out of or resulting from another Party's action or inactions of its obligations under this APSA on behalf of the indemnifying Party, except in cases of gross negligence or intentional wrongdoing by the Indemnified Party.

16.1.1 Indemnified Party. If an Indemnified Party is entitled to indemnification under this Article 16 as a result of a claim by a third party, and the Indemnifying Party fails, after notice and reasonable opportunity to proceed under Article 16.1 to assume the defense of such claim, such Indemnified Party may at the expense of the Indemnifying Party contest, settle or consent to the entry of any judgment with respect to, or pay in full, such claim.

16.1.2 Indemnifying Party. If an Indemnifying Party is obligated to indemnify and hold any Indemnified Party harmless under this Article 16, the amount owing to the Indemnified Party shall be the amount of such Indemnified Party's actual Loss, net of any insurance or other recovery.

16.1.3 Indemnity Procedures. Promptly after receipt by an Indemnified Party of any claim or notice of the commencement of any action or administrative or legal proceeding or investigation as to which the indemnity provided for in Article 16.1 may apply, the Indemnified Party shall notify the Indemnifying Party of such fact. Any failure of or delay in such notification shall not affect a Party's indemnification obligation unless such failure or delay is materially prejudicial to the indemnifying Party.

The Indemnifying Party shall have the right to assume the defense thereof with counsel designated by such Indemnifying Party and reasonably satisfactory to the Indemnified Party. If the defendants in any such action include one or more Indemnified Parties and the Indemnifying Party and if the Indemnified Party reasonably concludes that there may be legal defenses available to it and/or other Indemnified Parties which are different from or additional to those available to the Indemnifying Party, the Indemnified Party shall have the right to select separate counsel to assert such legal defenses and to otherwise participate in the defense of such action on its own behalf. In such instances, the Indemnifying Party shall only be required to pay the fees and expenses of one additional attorney to represent an Indemnified Party or Indemnified Parties having such differing or additional legal defenses.

The Indemnified Party shall be entitled, at its expense, to participate in any such action, suit or proceeding, the defense of which has been assumed by the Indemnifying Party. Notwithstanding the foregoing, the

Indemnifying Party (i) shall not be entitled to assume and control the defense of any such action, suit or proceedings if and to the extent that, in the opinion of the Indemnified Party and its counsel, such action, suit or proceeding involves the potential imposition of criminal liability on the Indemnified Party, or there exists a conflict or adversity of interest between the Indemnified Party and the Indemnifying Party, in such event the Indemnifying Party shall pay the reasonable expenses of the Indemnified Party, and (ii) shall not settle or consent to the entry of any judgment in any action, suit or proceeding without the consent of the Indemnified Party, which shall not be unreasonably withheld, conditioned or delayed.

- 16.2 Consequential Damages.** In no event shall any Party be liable under any provision of this APSA for any losses, damages, costs or expenses for any special, indirect, incidental, consequential, or punitive damages, including but not limited to loss of profit or revenue, loss of the use of equipment, cost of capital, cost of temporary equipment or services, whether based in whole or in part in contract, in tort, including negligence, strict liability, or any other theory of liability; provided, however, that damages for which a Party may be liable to another Party under another agreement will not be considered to be special, indirect, incidental, or consequential damages hereunder.

ARTICLE 17. ASSIGNMENT

- 17.1 Assignment.** This APSA may be assigned by a Party only with the written consent of the other Party; provided that a Party may assign this APSA without the consent of the other Party to any Affiliate of the assigning Party with an equal or greater credit rating and with the legal authority and operational ability to satisfy the obligations of the assigning Party under this APSA including any cost cap; and provided further that the Approved Project Sponsor shall have the right to assign this APSA, without the consent of the CAISO, for collateral security purposes to aid in providing financing for the Project, provided that the Approved Project Sponsor will promptly notify the CAISO of any such assignment. Any financing arrangement entered into by the Approved Project Sponsor pursuant to this Article will provide that prior to or upon the exercise of the secured party's, trustee's or mortgagee's assignment rights pursuant to said arrangement, the secured creditor, the trustee or mortgagee will notify the CAISO of the date and particulars of any such exercise of assignment right(s). Any attempted assignment that violates this Article is void and ineffective. Any assignment under this APSA shall not relieve a Party of its obligations, nor shall a Party's obligations be enlarged, in whole or in part, by reason thereof. Where required, consent to assignment will not be unreasonably withheld, conditioned or delayed.

ARTICLE 18. SEVERABILITY

- 18.1 Severability.** If any provision in this APSA is finally determined to be invalid, void or unenforceable by any court or other Governmental Authority having jurisdiction, such determination shall not invalidate, void or make unenforceable any other provision, agreement or covenant of this APSA.

ARTICLE 19. COMPARABILITY

- 19.1 Comparability.** The Parties will comply with all applicable comparability and code of conduct laws, rules and regulations, as amended from time to time.

ARTICLE 20. CONFIDENTIALITY

- 20.1 Confidentiality.** Confidential Information shall include, without limitation, all information relating to a Party's technology, research and development, business affairs, and pricing, and any information supplied by any of the Parties to the other Parties prior to the execution of this APSA.

Information is Confidential Information only if it is clearly designated or marked in writing as confidential on the face of the document, or, if the information is conveyed orally or by inspection, if the Party providing the information orally informs the Parties receiving the information that the information is confidential.

If requested by any Party, the other Parties shall provide in writing, the basis for asserting that the information referred to in this Article warrants confidential treatment, and the requesting Party may disclose such writing to the appropriate Governmental Authority. Each Party shall be responsible for the costs associated with affording confidential treatment to its information.

- 20.1.1 Term.** During the term of this APSA, and for a period of three (3) years after the expiration or termination of this APSA, except as otherwise provided in this Article, each Party shall hold in confidence and shall not disclose to any person Confidential Information.

- 20.1.2 Scope.** Confidential Information shall not include information that the receiving Party can demonstrate (1) is generally available to the public other than as a result of a disclosure by the receiving Party; (2) was in the lawful possession of the receiving Party on a non-confidential basis before receiving it from the disclosing Party; (3) was supplied to the receiving Party without restriction by a third party, who, to the knowledge of the receiving Party after due inquiry, was under no obligation to the disclosing Party to keep such information confidential; (4) was independently developed by the receiving Party without reference to Confidential Information of the disclosing Party; (5) is, or becomes, publicly known, through no wrongful act or omission of the receiving Party or Breach of

this APSA; or (6) is required, in accordance with Article 20.1.7 of this APSA, Order of Disclosure, to be disclosed by any Governmental Authority or is otherwise required to be disclosed by law or subpoena, or is necessary in any legal proceeding establishing rights and obligations under this APSA. Information designated as Confidential Information will no longer be deemed confidential if the Party that designated the information as confidential notifies the other Parties that it no longer is confidential.

20.1.3 Release of Confidential Information. No Party shall release or disclose Confidential Information to any other person, except to its employees, consultants, Affiliates (limited by the Standards of Conduct requirements set forth in Part 358 of FERC's Regulations, 18 C.F.R. 358), subcontractors, or to parties who may be or considering providing financing to or equity participation with the Approved Project Sponsor, or to potential purchasers or assignees of the Approved Project Sponsor, on a need-to-know basis in connection with this APSA, unless such person has first been advised of the confidentiality provisions of this Article and has agreed to comply with such provisions. Notwithstanding the foregoing, a Party providing Confidential Information to any person shall remain primarily responsible for any release of Confidential Information in contravention of this Article.

20.1.4 Rights. Each Party retains all rights, title, and interest in the Confidential Information that each Party discloses to the other Parties. The disclosure by each Party to the other Parties of Confidential Information shall not be deemed a waiver by a Party or any other person or entity of the right to protect the Confidential Information from public disclosure.

20.1.5 No Warranties. The mere fact that a Party has provided Confidential Information does not constitute a warranty or representation as to its accuracy or completeness. In addition, by supplying Confidential Information, no Party obligates itself to provide any particular information or Confidential Information to the other Parties or to enter into any further agreements or proceed with any other relationship or joint venture.

20.1.6 Standard of Care. Each Party shall use at least the same standard of care to protect Confidential Information it receives as it uses to protect its own Confidential Information from unauthorized disclosure, publication or dissemination. Each Party may use Confidential Information solely to fulfill its obligations to the other Parties under this APSA or its regulatory requirements.

20.1.7 Order of Disclosure. If a court or a Government Authority or entity with the right, power, and apparent authority to do so requests or requires any Party, by subpoena, oral deposition, interrogatories, requests for

production of documents, administrative order, or otherwise, to disclose Confidential Information, that Party shall provide the other Parties with prompt notice of such request(s) or requirement(s) so that the other Parties may seek an appropriate protective order or waive compliance with the terms of this APSA. Notwithstanding the absence of a protective order or waiver, the Party may disclose such Confidential Information which, in the opinion of its counsel, the Party is legally compelled to disclose. Each Party will use Reasonable Efforts to obtain reliable assurance that confidential treatment will be accorded any Confidential Information so furnished.

20.1.8 Termination of Agreement. Upon termination of this APSA for any reason, each Party shall, within ten (10) Calendar Days of receipt of a written request from another Party, use Reasonable Efforts to destroy, erase, or delete (with such destruction, erasure, and deletion certified in writing to the other Party) or return to the other Party, without retaining copies thereof, any and all written or electronic Confidential Information received from the other Party.

20.1.9 Remedies. The Parties agree that monetary damages would be inadequate to compensate a Party for another Party's Breach of its obligations under this Article. Each Party accordingly agrees that the other Parties shall be entitled to equitable relief, by way of injunction or otherwise, if the first Party Breaches or threatens to Breach its obligations under this Article, which equitable relief shall be granted without bond or proof of damages, and the receiving Party shall not plead in defense that there would be an adequate remedy at law. Such remedy shall not be deemed an exclusive remedy for the Breach of this Article, but shall be in addition to all other remedies available at law or in equity. The Parties further acknowledge and agree that the covenants contained herein are necessary for the protection of legitimate business interests and are reasonable in scope. No Party, however, shall be liable for indirect, incidental, or consequential or punitive damages of any nature or kind resulting from or arising in connection with this Article.

20.1.10 Disclosure to FERC, its Staff, or a State. Notwithstanding anything in this Article to the contrary, and pursuant to 18 C.F.R. section 1b.20, if FERC or its staff, during the course of an investigation or otherwise, requests information from one of the Parties that is otherwise required to be maintained in confidence pursuant to this APSA, the Party shall provide the requested information to FERC or its staff, within the time provided for in the request for information. In providing the information to FERC or its staff, the Party must, consistent with 18 C.F.R. section 388.112, request that the information be treated as confidential and non-public by FERC and its staff and that the information be withheld from public disclosure. Parties are prohibited from notifying the other Parties to this APSA prior to

the release of the Confidential Information to FERC or its staff. The Party shall notify the other Parties to the APSA when it is notified by FERC or its staff that a request to release Confidential Information has been received by FERC, at which time any of the Parties may respond before such information would be made public, pursuant to 18 C.F.R. Section 388.112. Requests from a state regulatory body conducting a confidential investigation shall be treated in a similar manner if consistent with the applicable state rules and regulations.

20.1.11 Subject to the exception in Article 20.1.10. Confidential Information shall not be disclosed by the other Parties to any person not employed or retained by the other Parties, except to the extent disclosure is (i) required by law; (ii) reasonably deemed by the disclosing Party to be required to be disclosed in connection with a dispute between or among the Parties, or the defense of litigation or dispute; (iii) otherwise permitted by consent of the other Parties, such consent not to be unreasonably withheld; or (iv) necessary to fulfill its obligations under this APSA or as a transmission service provider or a Balancing Authority including disclosing the Confidential Information to a regional or national reliability organization. The Party asserting confidentiality shall notify the other Parties in writing of the information it claims is confidential. Prior to any disclosures of another Party's Confidential Information under this subparagraph, or if any third party or Governmental Authority makes any request or demand for any of the information described in this subparagraph, the disclosing Party agrees to promptly notify the other Party in writing and agrees to assert confidentiality and cooperate with the other Party in seeking to protect the Confidential Information from public disclosure by confidentiality agreement, protective order or other reasonable measures.

ARTICLE 21. ENVIRONMENTAL RELEASES

21.1 Each Party shall notify the other Parties, first orally and then in writing, of the release of any Hazardous Substances, any asbestos or lead abatement activities, or any type of remediation activities related to the Project or the Interconnection Facilities, each of which may reasonably be expected to affect the other Parties. The notifying Party shall (i) provide the notice as soon as practicable, provided such Party makes a good faith effort to provide the notice no later than twenty-four hours after such Party becomes aware of the occurrence; and (ii) promptly furnish to the other Parties copies of any publicly available reports filed with any Governmental Authorities addressing such events.

ARTICLE 22. INFORMATION ACCESS AND AUDIT RIGHTS

22.1 Information Access. Each Party (the "disclosing Party") shall make available to the other Party information that is in the possession of the disclosing Party and is

necessary in order for the other Party to (i) verify the costs incurred by the disclosing Party for which the other Party is responsible under this APSA; and (ii) carry out its obligations and responsibilities under this APSA. The Parties shall not use such information for purposes other than those set forth in this Article 22.1 and to enforce their rights under this APSA. Nothing in this Article shall obligate the CAISO to make available to a Party any third party information in its possession or control if making such third party information available would violate a CAISO Tariff restriction on the use or disclosure of such third party information.

22.2 Reporting of Non-Force Majeure Events. Each Party (the “notifying Party”) shall notify the other Parties when the notifying Party becomes aware of its inability to comply with the provisions of this APSA for a reason other than a Force Majeure event. The Parties agree to cooperate with each other and provide necessary information regarding such inability to comply, including the date, duration, reason for the inability to comply, and corrective actions taken or planned to be taken with respect to such inability to comply. Notwithstanding the foregoing, notification, cooperation or information provided under this Article shall not entitle the Party receiving such notification to allege a cause for anticipatory breach of this APSA.

22.3 Audit Rights. Subject to the requirements of confidentiality under Article 20 of this APSA, the CAISO audit rights shall include audit of the Approved Project Sponsor costs pertaining to performance or satisfaction of obligations under this APSA.

22.3.1 The CAISO shall have the right, during normal business hours, and upon prior reasonable notice to the Approved Project Sponsor, to audit at its own expense the accounts and records pertaining to satisfaction of obligations under this APSA. Subject to Article 22.3.2, any audit authorized by this Article shall be performed at the offices where such accounts and records are maintained and shall be limited to those portions of such accounts and records that relate to performance and satisfaction of obligations under this APSA. The Approved Project Sponsor shall keep such accounts and records for a period equivalent to the audit rights periods described in Article 22.4.

22.3.2 Notwithstanding anything to the contrary in Article 22.3, the Approved Project Sponsors’ rights to audit the CAISO’s accounts and records shall be as set forth in Section 21.1 of the CAISO Tariff.

22.4 Audit Rights Period for Construction-Related Accounts and Records.

Accounts and records related to the design, engineering, procurement, and construction of Project constructed by the Approved Project Sponsor shall be subject to audit and verification by the CAISO for a period of twenty-four months following the issuance of a final cost summary in accordance with Article 5.2.7.

ARTICLE 23. SUBCONTRACTORS

23.1 General. Nothing in this APSA shall prevent a Party from utilizing the services of any subcontractor as it deems appropriate to perform its obligations under this APSA; provided, however, that each Party shall require its subcontractors to comply with all applicable terms and conditions of this APSA in providing such services and each Party shall remain primarily liable to the other Party for the performance of such subcontractor.

23.2 Responsibility of Principal. The creation of any subcontract relationship shall not relieve the hiring Party of any of its obligations under this APSA. The hiring Party shall be fully responsible to the other Parties for the acts or omissions of any subcontractor the hiring Party hires as if no subcontract had been made; provided, however, that in no event shall the CAISO or Participating TO be liable for the actions or inactions of the Approved Project Sponsor or its subcontractors with respect to obligations of the Approved Project Sponsor under Article 4 of this APSA. Any applicable obligation imposed by this APSA upon the hiring Party shall be equally binding upon, and shall be construed as having application to, any subcontractor of such Party.

ARTICLE 24. DISPUTES

24.1 General. All disputes arising out of or in connection with this APSA whereby relief is sought by or from the CAISO shall be settled in accordance with the provisions of Article 13 of the CAISO Tariff, except that references to the CAISO Tariff in such Article 13 of the CAISO Tariff shall be read as references to this APSA. Disputes arising out of or in connection with this APSA not subject to provisions of Article 13 of the CAISO Tariff shall be resolved as follows:

24.2 Submission. In the event either Party has a dispute, or asserts a claim, that arises out of or in connection with this APSA or its performance, such Party (the “disputing Party”) shall provide the other Party with written notice of the dispute or claim (“Notice of Dispute”). Such dispute or claim shall be referred to a designated senior representative of each Party for resolution on an informal basis as promptly as practicable after receipt of the Notice of Dispute by the other Party. In the event the designated representatives are unable to resolve the claim or dispute through unassisted or assisted negotiations within thirty (30) Calendar Days of the other Party’s receipt of the Notice of Dispute, such claim or dispute may, upon mutual agreement of the Parties, be submitted to arbitration and resolved in accordance with the arbitration procedures set forth below. In

the event the Parties do not agree to submit such claim or dispute to arbitration, each Party may exercise whatever rights and remedies it may have in equity or at law consistent with the terms of this APSA.

- 24.3 External Arbitration Procedures.** Any arbitration initiated under this APSA shall be conducted before a single neutral arbitrator appointed by the Parties. If the Parties fail to agree upon a single arbitrator within ten (10) Calendar Days of the submission of the dispute to arbitration, each Party shall choose one arbitrator who shall sit on a three-member arbitration panel. The two arbitrators so chosen shall within twenty (20) Calendar Days select a third arbitrator to chair the arbitration panel. In either case, the arbitrators shall be knowledgeable in electric utility matters, including electric transmission and bulk power issues, and shall not have any current or past substantial business or financial relationships with any party to the arbitration (except prior arbitration). The arbitrator(s) shall provide each of the Parties an opportunity to be heard and, except as otherwise provided herein, shall conduct the arbitration in accordance with the Commercial Arbitration Rules of the American Arbitration Association (“Arbitration Rules”) and any applicable FERC regulations; provided, however, in the event of a conflict between the Arbitration Rules and the terms of this Article, the terms of this Article shall prevail.
- 24.4 Arbitration Decisions.** Unless otherwise agreed by the Parties, the arbitrator(s) shall render a decision within ninety (90) Calendar Days of appointment and shall notify the Parties in writing of such decision and the reasons therefor. The arbitrator(s) shall be authorized only to interpret and apply the provisions of this APSA and shall have no power to modify or change any provision of this Agreement in any manner. The decision of the arbitrator(s) shall be final and binding upon the Parties, and judgment on the award may be entered in any court having jurisdiction. The decision of the arbitrator(s) may be appealed solely on the grounds that the conduct of the arbitrator(s), or the decision itself, violated the standards set forth in the Federal Arbitration Act or the Administrative Dispute Resolution Act. The final decision of the arbitrator(s) must also be filed with FERC if it affects jurisdictional rates, terms and conditions of service, Interconnection Facilities, or Network Upgrades.
- 24.5 Costs.** Each Party shall be responsible for its own costs incurred during the arbitration process and for the following costs, if applicable: (1) the cost of the arbitrator chosen by the Party to sit on the three member panel and one half of the cost of the third arbitrator chosen; or (2) one half the cost of the single arbitrator jointly chosen by the Parties.

ARTICLE 25. REPRESENTATIONS, WARRANTIES AND COVENANTS

- 25.1 General.** Each Party makes the following representations, warranties and covenants:

- 25.1.1 Good Standing.** Such Party is duly organized, validly existing and in good standing under the laws of the state in which it is organized, formed, or incorporated, as applicable; that it is qualified to do business in the state or states in which the Interconnection Facilities and Network Upgrades owned by such Party, as applicable, are located; and that it has the corporate power and authority to own its properties, to carry on its business as now being conducted and to enter into this APSA and carry out the transactions contemplated hereby and perform and carry out all covenants and obligations on its part to be performed under and pursuant to this APSA.
- 25.1.2 Authority.** Such Party has the right, power and authority to enter into this APSA, to become a Party hereto and to perform its obligations hereunder. This APSA is a legal, valid and binding obligation of such Party, enforceable against such Party in accordance with its terms, except as the enforceability thereof may be limited by applicable bankruptcy, insolvency, reorganization or other similar laws affecting creditors' rights generally and by general equitable principles (regardless of whether enforceability is sought in a proceeding in equity or at law).
- 25.1.3 No Conflict.** The execution, delivery and performance of this APSA does not violate or conflict with the organizational or formation documents, or bylaws or operating agreement, of such Party, or any judgment, license, permit, order, material agreement or instrument applicable to or binding upon such Party or any of its assets.
- 25.1.4 Consent and Approval.** Such Party has sought or obtained, or, in accordance with this APSA will seek or obtain, each consent, approval, authorization, order, or acceptance by any Governmental Authority in connection with the execution, delivery and performance of this APSA, and it will provide to any Governmental Authority notice of any actions under this APSA that are required by Applicable Laws and Regulations.
- 25.1.5 Existing Ownership and Property Rights.** Nothing in this APSA shall be construed to diminish rights or title to any of its personal or real property in, under or beyond the Project and its facilities, including but not limited to all real property rights held in fee by the Imperial Irrigation District ("IID"), obtained by easement or other right, whether recorded or unrecorded, whether arising before or after the Effective Date and whether obtained by condemnation, prescription, express grant or otherwise.

ARTICLE 26. MISCELLANEOUS

- 26.1 Binding Effect.** This APSA and the rights and obligations hereof, shall be binding upon and shall inure to the benefit of the successors and assigns of the Parties hereto.
- 26.2 Conflicts.** In the event of a conflict between the body of this APSA and any attachment, appendices or exhibits hereto, the terms and provisions of the body of this APSA shall prevail and be deemed the final intent of the Parties.
- 26.3 Rules of Interpretation.** This APSA, unless a clear contrary intention appears, shall be construed and interpreted as follows: (1) the singular number includes the plural number and vice versa; (2) reference to any person includes such person's successors and assigns but, in the case of a Party, only if such successors and assigns are permitted by this APSA, and reference to a person in a particular capacity excludes such person in any other capacity or individually; (3) reference to any agreement (including this APSA), document, instrument or tariff means such agreement, document, instrument, or tariff as amended or modified and in effect from time to time in accordance with the terms thereof and, if applicable, the terms hereof; (4) reference to any Applicable Laws and Regulations means such Applicable Laws and Regulations as amended, modified, codified, or reenacted, in whole or in part, and in effect from time to time, including, if applicable, rules and regulations promulgated thereunder; (5) unless expressly stated otherwise, reference to any Article, Section or Appendix means such Article of this APSA or such Appendix to this APSA, or such Section to the CAISO Tariff or such Appendix to the CAISO Tariff, as the case may be; (6) "hereunder", "hereof", "herein", "hereto" and words of similar import shall be deemed references to this APSA as a whole and not to any particular Article or other provision hereof or thereof; (7) "including" (and with correlative meaning "include") means including without limiting the generality of any description preceding such term; and (8) relative to the determination of any period of time, "from" means "from and including", "to" means "to but excluding" and "through" means "through and including".
- 26.4 Entire Agreement.** This APSA, including all Appendices and Schedules attached hereto, constitutes the entire agreement among the Parties with reference to the subject matter hereof, and supersedes all prior and contemporaneous understandings or agreements, oral or written, between or among the Parties with respect to the subject matter of this APSA. There are no other agreements, representations, warranties, or covenants which constitute any part of the consideration for, or any condition to, any Party's compliance with its obligations under this APSA.
- 26.5 No Third Party Beneficiaries.** This APSA is not intended to and does not create rights, remedies, or benefits of any character whatsoever in favor of any persons, corporations, associations, or entities other than the Parties, and the

obligations herein assumed are solely for the use and benefit of the Parties, their successors in interest and, where permitted, their assigns.

26.6 Waiver. The failure of a Party to this APSA to insist, on any occasion, upon strict performance of any provision of this APSA will not be considered a waiver of any obligation, right, or duty of, or imposed upon, such Party.

Any waiver at any time by either Party of its rights with respect to this APSA shall not be deemed a continuing waiver or a waiver with respect to any other failure to comply with any other obligation, right, duty of this APSA. Termination or Default of this APSA for any reason by the Approved Project Sponsor shall not constitute a waiver of the Approved Project Sponsor's legal rights to obtain an interconnection from the CAISO. Any waiver of this APSA shall, if requested, be provided in writing.

26.7 Headings. The descriptive headings of the various Articles of this APSA have been inserted for convenience of reference only and are of no significance in the interpretation or construction of this APSA.

26.8 Multiple Counterparts. This APSA may be executed in two or more counterparts, each of which is deemed an original but all constitute one and the same instrument.

26.9 Amendment. The Parties may by mutual agreement amend this APSA by a written instrument duly executed by all of the Parties. Such amendment shall become effective and a part of this APSA upon satisfaction of all Applicable Laws and Regulations.

26.10 Modification by the Parties. Except as described in Appendices B and E, the Parties may by mutual agreement amend the Appendices to this APSA by a written instrument duly executed by all of the Parties. Such amendment shall become effective and a part of this APSA upon satisfaction of all Applicable Laws and Regulations.

26.11 Reservation of Rights. The CAISO has the right to make a unilateral filing with FERC to modify this APSA pursuant to section 205 or any other applicable provision of the Federal Power Act and FERC's rules and regulations thereunder with respect to the following Articles and Appendices of this APSA and with respect to any rates, terms and conditions, charges, classifications of service, rule or regulation. The Approved Project Sponsor and the CAISO shall have the right to make a unilateral filing with FERC to modify this APSA pursuant to section 206 or any other applicable provision of the Federal Power Act and FERC's rules and regulations thereunder; provided that each Party shall have the right to protest any such filing by another Party and to participate fully in any proceeding before FERC in which such modifications may be considered. Nothing in this APSA shall limit the rights of the Parties or of FERC under

sections 205 or 206 of the Federal Power Act and FERC's rules and regulations thereunder, except to the extent that the Parties otherwise mutually agree as provided herein.

26.12 No Partnership. This APSA shall not be interpreted or construed to create an association, joint venture, agency relationship, or partnership among the Parties or to impose any partnership obligation or partnership liability upon any Party. No Party shall have any right, power or authority to enter into any agreement or undertaking for, or act on behalf of, or to act as or be an agent or representative of, or to otherwise bind, another Party.

26.13 Joint and Several Obligations. Except as otherwise provided in this APSA, the obligations of the CAISO, and the Approved Project Sponsor are several, and are neither joint nor joint and several.

IN WITNESS WHEREOF, the Parties have executed this APSA in multiple originals, each of which shall constitute and be an original effective agreement among the Parties.

Imperial Irrigation District

By: James C. Hanks
Name: James C. Hanks
Title: Board President
Date: 3-4-14

California Independent System Operator Corporation

By: _____
Name: _____
Title: _____
Date: _____

IN WITNESS WHEREOF, the Parties have executed this APSA in multiple originals, each of which shall constitute and be an original effective agreement among the Parties.

Imperial Irrigation District

By: _____
Name: _____
Title: _____
Date: _____

California Independent System Operator Corporation

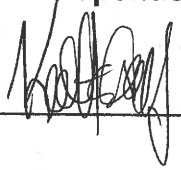
By:  _____
Name: _____
Title: **KEITH E. CASEY, PH.D., VICE PRESIDENT
MARKET & INFRASTRUCTURE DEVELOPMENT**
Date: 3/10/14 _____

MS

Appendices to APSA

Appendix A Project Details

Appendix B Milestones

Appendix C Security Arrangements Details

Appendix D Addresses for Delivery of Notices and Billings

Appendix E Approved Project Sponsor's Costs of Project

Appendix A

Project Details

1. Description:

The CAISO analyzed the location of generation projects in the CAISO queue seeking interconnection to the Imperial Valley (“IV”) substation and considered transmission configurations that might reduce permitting and other concerns in the area. The CAISO has also coordinated with IID and has been advised that IID plans to upgrade the IID IV-El Centro line (the “S” line) to enhance its ownership rights at the IV substation. The CAISO has reviewed such plans from IID. Based on this collaboration with IID and the need to provide an efficient means by which CAISO queue generation located in Imperial Valley can move forward to commercial operation, the CAISO has identified a policy-driven need for a 230 kV collector substation (located approximately one mile north of the IV substation) and a 230 kV transmission line connecting the collector substation to the IV substation, contingent upon IID looping the S line into the IID portion of the new collector substation, as depicted below:¹

2. Interconnection Facilities – Collector Station:

Switching Station Only

Nominal Phase to Phase Voltage: 230 kV

Initial Bus Configuration (DBDB, BAAH, SBSB, etc): Double breaker double bus (DBDB)

Ultimate Bus Configuration (DBDB, BAAH, SBSB, etc): Breaker and a half (BAAH)

Maximum Circuit Breaker Total Fault Clearing Time: 4 cycles

Initial Number of Lines: 2

Ultimate Number of Lines: 12 (Initially the collector station site is to be prepared for four bays and eight lines.)

Initial Number of CBs: 4

Ultimate Number of CBs: 18

Initial Minimum Bus Ampacity: 5,500 Amps Ultimate Bus Ampacity: 5,500 Amps

Minimum CB Ampacity: 4,000 Amps Minimum CB Interrupting Capability: 63 kA

Station Minimum BIL 1,050 kV (900 kV for solidly grounded systems)

Initial Reactive Power Requirements: None

Ultimate Reactive Power Requirements: To be determined

¹ Because the 230 kV line and substation will not become network facilities until IID completes the S line loop-in, these elements cannot be turned over to CAISO operational control until IID completes the network upgrades on its system.

Telemetry Requirements: Install the necessary equipment, including one RTU to monitor the typical bulk power elements such as MW, MVAR, and phase amps at each line and also kV at lines and buses and all circuit breaker status/control, protection relays status and alarms. The installed equipment will transmit information to the Participating TO's Grid Control Center.

Latest In Service Date: May, 2015

Low Profile Required: Subject to local permitting requirements

Gas Insulation Required: No

3. Network Upgrades:

Overhead Line Construction

Line Terminus 1: SDG&E Imperial Valley 230 kV Bus

Line Terminus 2: Proposed Collector Station 230 kV Bus

Nominal Phase to Phase Voltage: 230 kV

Minimum Continuous Ampacity - Summer: 3,000 Amps

Minimum Continuous Ampacity – Winter: 3,000 Amps

Minimum 4 Hour Emergency Ampacity – Summer: 4,050 Amps

Minimum 4 Hour Emergency Ampacity – Winter: 4,050 Amps

Minimum 30 Minute Emergency Ampacity – Summer: 4,380 Amps

Minimum 30 Minute Emergency Ampacity – Winter: 4,380 Amps

Approximate Line Impedance (Ohms): N/A

Approximate Series Compensation Level: N/A

Approximate Line Length: 1 mile

Latest In Service Date: May, 2015

Support Structures: Full double circuit tower with one side strung

Shield Wire Required: Optical ground wire (minimum 6 pairs of fibers)

Failure Containment Loading Mitigation (anti-cascade structures, etc.): Per applicable codes

Shield Wire Ground Fault Withstand Ampacity: Coordinate with interconnecting PTOs

Aeolian Vibration Control (Conductor and Shield Wire): Vibration dampers must be installed on all conductors and overhead shield wires, with the exception of slack spans.

Transmission Line Minimum BIL: 1,050 kV (900 kV for solidly grounded systems)

Minimum ROW Width: Per applicable codes

Governing Design and Construction Standards: (GO 95, NESC Code, applicable municipal codes)

4. **Distribution Upgrades:** None

5. **Diagram of Project:**

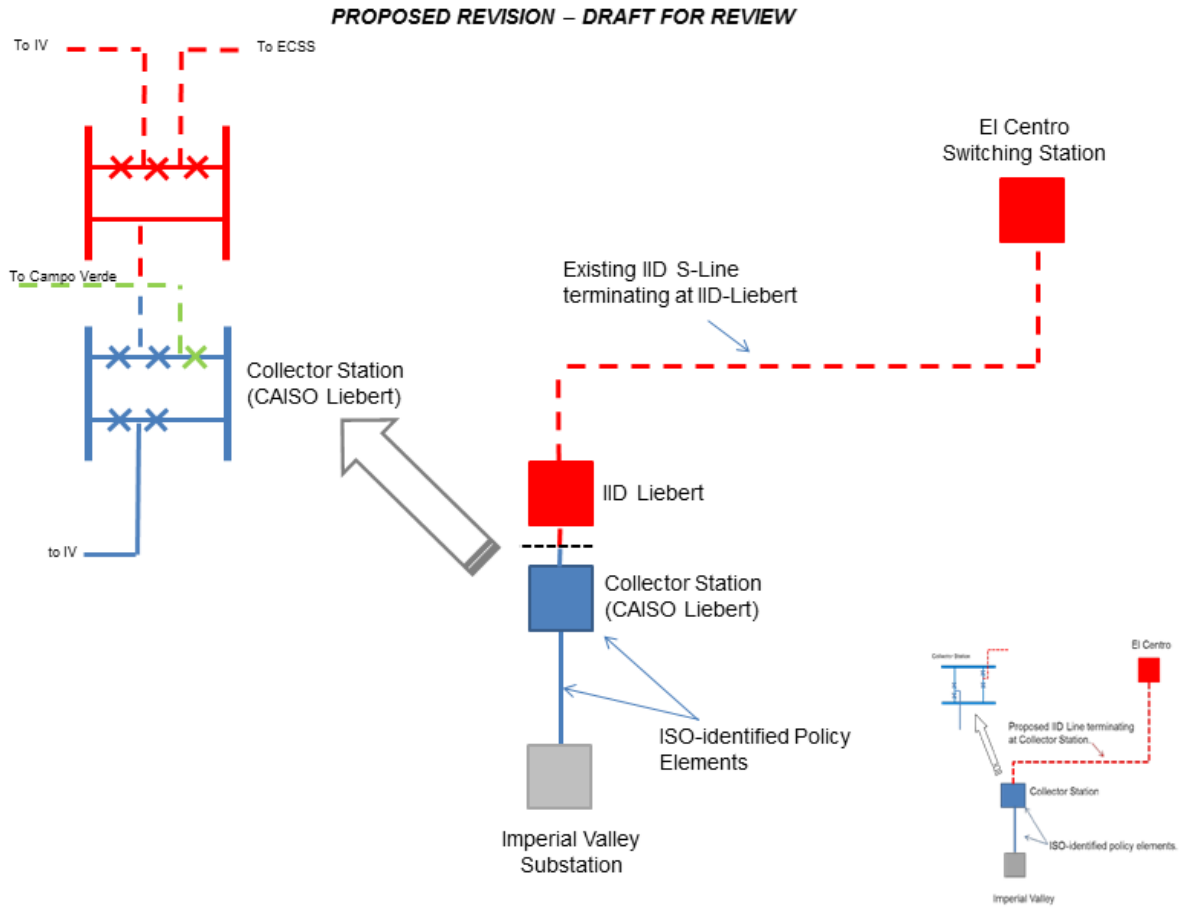

Appendix B

Milestones

1. Milestone Dates:

| Item | Milestone | Responsible Party | Due Date ¹⁷ |
|------|---|--------------------------|------------------------|
| 1 | Submit Construction Plan in accordance with Article 5.4.1 of this Agreement. | Approved Project Sponsor | Completed |
| 2 | Commence development activities including commencement of regulatory approvals; acquisition of land; permits | Approved Project Sponsor | Completed |
| 3 | Complete development activities | Approved Project Sponsor | Completed |
| 4 | Commence engineering design | Approved Project Sponsor | Completed |
| 5 | Commence procurement including material and resources | Approved Project Sponsor | April 7, 2014** |
| 6 | Submit Construction Plan Status Report in accordance with Article 5.4.2 of this Agreement. | Approved Project Sponsor | Completed |
| 7 | Submit Construction Plan Status Report in accordance with Article 5.4.2 of this Agreement. | Approved Project Sponsor | May 27, 2014** |
| 8 | Submit a Participating TO application for the Project to the ISO in accordance with Section 4.3.1.1 of the CAISO Tariff | Approved Project Sponsor | July 1, 2014** |
| 9 | Complete engineering design | Approved Project Sponsor | July 2, 2014** |
| 10 | Submit Construction Plan Status Report in accordance with Article 5.4.2 of this Agreement. | Approved Project Sponsor | August 25, 2014** |
| 11 | Commence Construction | Approved Project Sponsor | September 10, 2014** |
| 12 | Submit Project specifications in accordance with Article 5.8.1 of this Agreement | Approved Project Sponsor | October 5, 2014** |
| 13 | Provide comments on Project specifications | CAISO | November 4, 2014** |
| 14 | Complete procurement including material and resources | Approved Project Sponsor | November 19, 2014** |
| 15 | Submit Construction Plan Status Report in accordance with Article 5.4.2 of this Agreement. | Approved Project Sponsor | November 23, 2014** |
| 16 | Submit final Project specifications in accordance with Article 5.8.1 of this Agreement | Approved Project Sponsor | January 3, 2015** |
| 17 | Provide comments on final Project specifications | CAISO | February 2, 2015** |
| 18 | Submit Construction Plan Status Report in accordance with Article 5.4.2 of this Agreement. | Approved Project Sponsor | February 21, 2015** |

| Item | Milestone | Responsible Party | Due Date ^{1/} |
|------|--|--------------------------|------------------------|
| 19 | Commence Testing | Approved Project Sponsor | April 3, 2015** |
| 20 | Complete Construction | Approved Project Sponsor | May 14, 2015** |
| 21 | Energize Project | Approved Project Sponsor | May 15, 2015* |
| 22 | In accordance with Article 5.2.8 and 5.8.3 provide final "as-built" drawings, information and other documents. | Approved Project Sponsor | September 12, 2015** |
| 23 | In accordance with Article 5.2.7 provide final costs of the Project. | Approved Project Sponsor | May 15, 2016** |

^{1/} Dates in this Appendix B are good faith estimates and can be modified as follows:

- * Change in milestone date requires an amendment to this APSA pursuant to Section 26.10.
- ** Change in milestone date can be agreed to in writing by the representatives listed in Appendix D to this APSA without further regulatory approval.

Appendix C

Security Arrangements Details

Infrastructure security of CAISO Controlled Grid equipment and operations and control hardware and software is essential to ensure day-to-day CAISO Controlled Grid reliability and operational security. FERC will expect the CAISO, and Approved Project Sponsors interconnected to the CAISO Controlled Grid to comply with the recommendations offered by the President's Critical Infrastructure Protection Board and, eventually, best practice recommendations from the electric reliability authority. All public utilities will be expected to meet basic standards for system infrastructure and operational security, including physical, operational, and cyber-security practices.

The Approved Project Sponsor shall meet the requirements for security implemented pursuant to the CAISO Tariff, including the CAISO's standards for information security posted on the CAISO's internet web site at the following internet address: <http://www.caiso.com/pubinfo/info-security/index.html>.

Appendix D

Addresses for Delivery of Notices and Billings

Notices:

Approved Project Sponsor:

Imperial Irrigation District
Attention: General Manager
333 East Barioni Boulevard
P.O. Box 937
Imperial, CA 92251

With a copy to:

Imperial Irrigation District
Attention: Energy Manager
333 East Barioni Boulevard
P.O. Box 937
Imperial, CA 92251
Email: TransPlan@iid.com

CAISO:

California ISO
Attn: Infrastructure Contracts & Management
250 Outcropping Way
Folsom, CA 95630
Email: QueueManagement@CAISO.com

Alternative Forms of Delivery of Notices (telephone, facsimile or e-mail):

Approved Project Sponsor:

Jamie Asbury
jasbury@iid.com
(760) 482-3379

CAISO:

Deb Le Vine
dlevine@caiso.com
(916) 351-2144

Appendix E

Approved Project Sponsor's Costs of Project

The Approved Project Sponsor agrees to a binding cost cap of \$14.3 Million for the Project. In addition, IID will not include interest during construction. The estimated cost components for the Project are as follows:

| | |
|--|----------------------|
| Substation Costs | |
| Environmental & Real Estate | \$ 585,000 |
| Engineering | 533,329 |
| Materials & Equipment | 3,518,892 |
| Construction/Inspection/Construction Mgmt. | <u>2,731,589</u> |
| Subtotal | \$ 7,368,810 |
| Transmission Cost | |
| Environmental & Real Estate | \$ 215,000 |
| Engineering | 162,464 |
| Materials & Equipment | 1,441,677 |
| Construction/Inspection/Construction Mgmt. | <u>980,859</u> |
| Subtotal | \$ 2,800,000 |
| Project Management | |
| | \$ 233,792 |
| Bay Position at IV Substation | |
| | \$ 1,500,000 |
| Subtotal | \$ 11,902,602 |
| Contingencies | <u>2,380,520</u> |
| Total | \$ 14,283,122 |

The Approved Project Sponsor may adjust the amounts in each cost category as needed during the term of the APSA provided the total Project cost does not exceed \$14,14,283,122.

In accordance with Article 5.2.7, the Approved Project Sponsor shall provide a summary of the final cost of the construction of the Project as soon as reasonably practicable within twelve months of the completion of construction.