

May 28, 2010

VIA HAND DELIVERY

Honorable Kimberly D. Bose
Secretary
Federal Energy Regulatory Commission
888 First Street, NE
Washington, DC 20426

**Re: Large Generator Interconnection Agreement Between and Among
Arizona Public Service Company, Imperial Irrigation District, San Diego Gas &
Electric Company, the California Independent System Operator Corporation,
Agua Caliente Solar, LLC, and North Gila River Development, LLC,
Docket No. ER10-____-000**

Dear Ms. Bose:

Pursuant to Section 205 of the Federal Power Act ("FPA"), 16 U.S.C. § 824d, and Part 35 of the Federal Energy Regulatory Commission's ("FERC" or "Commission") Regulations, 18 C.F.R. Part 35 (2009), Arizona Public Service Company ("APS"), San Diego Gas & Electric Company ("SDG&E")¹, and the California Independent System Operator Corporation ("CAISO") (collectively the "Filing Parties") hereby submit for filing a partially executed Large Generator Interconnection Agreement ("Agreement")² between and among themselves and the Imperial Irrigation District ("IID"),³ Agua Caliente Solar, LLC ("Agua Caliente"), and North Gila River Development, LLC ("North Gila") (collectively the signatories to the Agreement are referred to herein as the "Parties"). Although the Agreement has not yet been executed by two of the Parties, it is expected that it will be acted upon by their respective governing Boards within the next month. The Agreement is to become a service agreement under the terms of the APS, SDG&E, and CAISO tariffs.⁴ Pursuant to the terms of the Agreement, the Interconnection

¹ While SDG&E management has authorized the filing of this Agreement, SDG&E has not yet signed the Agreement since the SDG&E Board of Directors must approve the signing of the Agreement, and SDG&E's Board will not meet until June 15, 2010.

² The Agreement has been executed, to date, by APS, CAISO, Agua Caliente, and North Gila.

³ IID has not yet executed the Agreement because, as a political subdivision of the State of California, IID must obtain the approval of its governing Board before doing so. IID intends to seek approval of this Agreement by its Board at a meeting that is expected to take place on June 22, 2010. IID is not a "public utility" under Sections 205 and 206 of the Federal Power Act. Therefore, IID is not submitting the Agreement for filing at FERC. The jurisdictional Filing Parties will, however, submit an informational filing to FERC apprising it of the action taken on this Agreement at the IID Board meeting.

⁴ The Agreement is designated by APS as APS FERC Electric Tariff, Fourteenth Revised Volume No. 2, Service Agreement No. 303. The Agreement is designated by SDG&E as SDG&E FERC Electric

Customer's proposed Generating Facility will interconnect to a transmission facility owned by multiple entities (*i.e.*, APS, IID, and SDG&E), one of which (*i.e.*, IID) is not a public utility subject to the Commission's jurisdiction under Sections 205 and 206 of the FPA.

The Agreement is being filed as a "non-conforming" Large Generator Interconnection Agreement (or "LGIA") pursuant to FERC Order No. 2003.⁵ However, as explained below and in Attachment A, the Interconnection Customer requested interconnection service for its proposed Generating Facility from both APS and the CAISO under their respective FERC-approved tariffs. As a result, many of the "non-conforming" provisions in this Agreement actually conform to, or are consistent with, either the CAISO's Large Generator Interconnection Agreement for Interconnection Requests in a Queue Cluster Window, which has been accepted by the Commission as CAISO tariff Appendix Z ("CAISO LGIA"),⁶ or the APS Standard Large Generator Interconnection Agreement, which has been accepted by the Commission as APS FERC Electric Tariff, Fourteenth Revised Volume No. 2, Appendix 6 to Attachment O ("APS LGIA"),⁷ and are "non-conforming" simply because the Commission-accepted *pro forma* LGIAs of the CAISO and APS differ in many respects.⁸ The Parties had to choose the provisions of one or both of these LGIAs where they differ in order for the Parties to combine their respective interconnection rights and obligations into a single Agreement. The explanations of these provisions in Section III below and in Attachment A demonstrate the substantial extent to which provisions that are not conforming to the *pro forma* LGIA of one Party are actually already accepted by the Commission as *pro forma* provisions of the other Party's LGIA. In these cases, the Commission should treat the provisions as effectively conforming to an already-accepted *pro forma* LGIA.

Volume 11, Service Agreement No. 27. The Agreement is designated as service agreement number 1566 pursuant to the CAISO FERC Electric Tariff, Fourth Replacement Volume No. II.

⁵ See *Standardization of Generator Interconnection Agreements and Procedures*, Order No. 2003, FERC Stats. & Regs. ¶ 31,146 at P 822-27 (2003), *order on reh'g*, Order No. 2003-A, FERC Stats. & Regs. ¶ 31,160, *order on reh'g*, Order No. 2003-B, FERC Stats. & Regs. ¶ 31,171 (2004), *order on reh'g*, Order No. 2003-C, FERC Stats. & Regs. ¶ 31,190 (2005), *aff'd sub nom. Nat'l Ass'n of Regulatory Util. Comm'rs v. FERC*, 475 F.3d 1277 (D.C. Cir. 2007).

⁶ See *California Indep. Sys Operator Corp.*, Docket No. ER08-1317, 124 FERC ¶ 61,292 (2008) (initial order approving tariff reforms instituted as part of CAISO's generator interconnection process reform); *order on reh'g*, 127 FERC ¶ 61,177 (2008); and 128 FERC ¶ 61,247 (2009) (order on compliance filing). The CAISO tariff also includes as Appendix V a Standard Large Generator Interconnection Agreement that is not applicable to interconnection requests in a queue cluster window. As the interconnection request submitted to the CAISO related to this Agreement was incorporated into a queue cluster window pursuant to the CAISO tariff, the CAISO LGIA in Appendix Z of the CAISO tariff is the appropriate version to which to compare this Agreement.

⁷ *Arizona Pub. Serv. Co.*, Docket No. ER07-1142 (letter order November 26, 2007).

⁸ The differences between the APS LGIA and the CAISO LGIA are shown for illustrative purposes in Attachment E to this filing.

Aside from the provisions necessary to reconcile the APS and CAISO LGIAs, the Agreement includes a number of special provisions that reflect special aspects of the Generating Facility, the ownership and operation of the transmission system to which it will interconnect, and the multiple Parties to the Agreement. The Agreement includes special provisions reflecting that the Generating Facility will use solar photovoltaic technology, which is not contemplated in many parts of either the APS or the CAISO *pro forma* LGIA. In addition, the Agreement includes a number of provisions that reflect that IID, one of the multiple owners of the joint transmission facility, is a governmental entity and not a public utility subject to FERC's jurisdiction under Sections 205 and 206 of the FPA. These provisions also reflect the fact that IID's individual transmission system is an Affected System for which an Affected System Study Agreement will be signed and for which an Affected System Construction and Operation Agreement may be needed.² The Agreement also includes several special provisions needed to address the two very distinct phases of the Generating Facility and the separate ownership of the phases by two different entities comprising the Interconnection Customer. Finally, a number of provisions are ministerial in nature, but necessary because there are more than two Parties to the Agreement, and the Parties' particular roles must be defined.

In short, the instant Agreement conforms directly to applicable provisions of either the APS tariff or the CAISO tariff, and deviates from those provisions only as necessary to accommodate the somewhat unusual multi-party, two-phased, solar facility characteristics of the Agreement.

I. BACKGROUND

A. The Hassayampa-North Gila Line (or Joint Participation Project)

The Agreement concerns interconnection of a proposed solar photovoltaic large electric generating facility to the Hassayampa-North Gila 500 kV transmission line which runs between the Hassayampa substation, near the Palo Verde Nuclear Power Plant in Arizona, and the North Gila substation, near the Arizona-California border. The line is known as the "Arizona Transmission System" and is a portion of the Southwest Power Link which extends from Arizona into California. No generators currently interconnect directly to this line.

The Hassayampa-North Gila line is jointly owned by APS, SDG&E, and IID under the Arizona Transmission System Participation Agreement ("Participation Agreement"),

² An interconnection request was not submitted directly to IID. Therefore, IID was brought into the negotiation of the Agreement in its role as a co-owner of the joint transmission facility and potentially as an Affected System. When used herein, the term "Affected System" has the meaning set forth in the Agreement, which is "an electric system other than the APS or SDG&E's Transmission Systems or IID's share of the JPP that may be affected by the proposed interconnection." When used herein, the terms "Affected System Study Agreement" and "Affected System Construction and Operation Agreement" shall also have the meanings set forth in the Agreement.

dated June 24, 1981, as amended.¹⁰ Pursuant to the Participation Agreement, APS acts as the operating agent with respect to the Hassayampa-North Gila line for itself, SDG&E, and IID. Under the Participation Agreement, the three transmission owners own capacity in the line in proportion to their ownership shares, which are 11% for APS, 12.78 % for IID, and 76.22 % for SDG&E. The Participation Agreement designates SDG&E as the scheduling agent. (Herein the Hassayampa-North Gila line will be referred to as the “Joint Participation Project” or “JPP.”)

As a result of electric restructuring in California, SDG&E was required to transfer operational control over its transmission facilities to the CAISO. SDG&E transferred operational control over SDG&E’s portion of the JPP to the CAISO by executing a Transmission Control Agreement (“TCA”). The TCA expressly indicates that SDG&E’s transfer of operational control of its portion of the JPP is subject to the Participation Agreement, which is listed as an encumbrance in an appendix to the TCA.¹¹ As a result of SDG&E’s role as scheduling agent under the Participation Agreement, the CAISO assumed that function pursuant to the TCA, and the JPP is deemed to be within the CAISO Balancing Authority Area.¹²

B. The Interconnection Customer

NextLight Renewable Power, LLC (“NextLight”), the parent of both Agua Caliente and North Gila, intends to build a 500 MW solar photovoltaic generating facility, to be located near Horn, Arizona, on land adjacent to the Joint Participation Project (the “Generating Facility”).

The Generating Facility is to be constructed in two phases. Phase A of the Generating Facility will be a 290 MW project to be constructed by Agua Caliente and is known as the “Agua Caliente Solar Project.” Phase B of the Generating Facility will be a 210 MW project to be constructed by North Gila. Collectively, Agua Caliente and North Gila are referred to herein as the “Interconnection Customer.”

¹⁰ See *Arizona Public Service Co.*, Docket No. ER94-276-000, *et al.*, delegated letter order (Nov. 4, 1994). APS submitted Amendment No. 1 to the Participation Agreement in Docket No. ER94-345-000. The Participation Agreement has been designated by APS as Rate Schedule FERC No. 224. SDG&E submitted Amendment No. 1 to the Participation Agreement in Docket No. ER94-336-000. The Participation Agreement has been designated by SDG&E as Rate Schedule FERC No. 104. For both APS and SDG&E, the Participation Agreement is effective June 24, 1981, and Amendment No. 1 is effective January 5, 1985.

¹¹ The Participation Agreement is listed in the TCA at FERC Electric Tariff No. 7, Second Replacement Transmission Control Agreement, Substitute First Revised Sheet No. 132 (SDG&E’s List of Encumbrances, Appendix B-2, p. 2, listing Participation Agreement). Also available at <http://www.caiso.com/docs/09003a6080/25/a3/09003a608025a3bd.pdf>. See *California Indep. Sys. Operator Corp.*, 117 FERC ¶ 61,029 (2006); *California Indep. System Operator Corp.*, Docket No. ER06-1360-002, delegated letter order issued Apr. 9, 2007.

¹² Herein the terms “Balancing Authority” and “Balancing Authority Area” have the meaning in the Agreement.

The Agua Caliente Solar Project is expected to become the nation's largest solar photovoltaic power plant when it achieves commercial operation. All required permits and approvals have been secured, except an order from FERC indicating that the Agreement has been accepted for filing. Agua Caliente has a power purchase agreement with Pacific Gas & Electric Co. ("PG&E"). The Energy Division of the California Public Utilities Commission issued a draft resolution approving the power purchase agreement on April 29, 2010, and a decision on the resolution is expected on June 3, 2010. Under this power purchase agreement PG&E, a participating transmission owner within the CAISO, is to purchase the output of Phase A of the Generating Facility. To make sales under this power purchase agreement, Agua Caliente must elect to designate the CAISO as the Balancing Authority.

Phase B of the Generating Facility, known as North Gila, will be a 210 MW solar photovoltaic generating facility. At the present time, there is no power purchase agreement for the output of this facility. The output may be sold into the CAISO Balancing Authority Area or another Balancing Authority Area, for example, that of APS, depending on the off-take customer.¹³

C. The Interconnection Process for this Generating Facility

NextLight made the original interconnection requests for the Generating Facility. NextLight submitted an interconnection request to APS in February of 2008 for energy resource interconnection service for a 500 MW generating facility in accordance with the APS Large Generator Interconnection Procedures, Attachment O to the Arizona Public Service Open Access Tariff ("APS LGIP").¹⁴ The APS LGIP, including the APS LGIA, is very similar to the Order No. 2003 *pro forma* LGIP (including *the pro forma* LGIA) developed by FERC.¹⁵

NextLight also submitted an interconnection request to the CAISO in June of 2008 for the 290 MW of output associated with Phase A of the Generating Facility, which is intended to be delivered into the CAISO system to PG&E. The interconnection request is in the transition cluster, which is the first group of interconnection requests the CAISO is analyzing on a cluster basis under its new Large Generator Interconnection Procedures for Interconnection Requests in a Queue Cluster Window, CAISO Tariff, Appendix Y

¹³ As described in more detail below in Sections III.C and III.G.1, the Agreement provides that if the Interconnection Customer designates the CAISO as the Balancing Authority Area for Phase B of the Generating Facility, an additional interconnection request to and interconnection studies by the CAISO may be required. The Agreement provides a procedure for such actions to be taken. Agreement at Appendix C, Section 4.

¹⁴ The APS Attachment O LGIP begins at Original Sheet No. 235, FERC Electric Tariff, Fourteenth Revised Volume No. 2, and was accepted for filing in *Arizona Pub. Serv. Co.*, Docket No. ER07-1142 (letter order November 26, 2007).

¹⁵ See Order No. 2003, Standard Large Generator Interconnection Procedures and Standard Large Generator Interconnection Agreement.

(“CAISO LGIP”).¹⁶ Other than the differing requested amounts, the interconnection requests made to APS and to the CAISO are substantially the same.¹⁷

Pursuant to the APS LGIP, APS prepared a system impact study and a facilities study, dated May 28, 2009,¹⁸ based on specifications and data provided by NextLight. The facilities study shows that the construction of a new switchyard is necessary to interconnect the Generating Facility to the JPP. The estimated cost for network upgrades and transmission owner interconnection facilities is expected to be approximately \$23 million for Phase A of the Generating Facility and approximately \$3.5 million for Phase B of the Generating Facility. The APS facilities study was approved by the Engineering and Operating Committee for the Joint Participation Project, which is comprised of representatives of APS, IID, and SDG&E.

Pursuant to the CAISO LGIP, the CAISO issued its Phase I Interconnection Study on July 24, 2009. As with the APS study, the CAISO Phase I Interconnection Study concluded that the primary reliability network upgrade required for interconnection is the construction of the switchyard. The study also identified a possible additional reliability network upgrade, a special protection scheme on the SDG&E transmission system at the Imperial Valley substation. Finally, the study indicated that interconnection of generating facilities in the cluster that included the interconnection request for the Agua Caliente Solar Project may have an impact on IID’s transmission system.

APS, as operating agent for the Joint Participation Project, tendered a large generator interconnection agreement (based on the APS LGIA) on behalf of the JPP transmission owners in August of 2009. The CAISO had also indicated its intent to tender its own LGIA. In an effort to address the two overlapping interconnection requests and at the request of NextLight, the Parties have worked diligently to negotiate the terms of the instant Agreement and to reconcile the differing provisions of the APS and CAISO LGIAs.

“Interconnection Financial Security,” as defined in the CAISO LGIP, was posted with the CAISO for Phase A on December 1, 2009, in accordance with the CAISO tariff, which allowed the interconnection request to remain in the interconnection study process. At

¹⁶ The CAISO LGIP begins at First Revised Sheet No. 1779, FERC Electric Tariff, Fourth Replacement Volume No. II, which was accepted in *California Indep. Sys. Operator Corp.*, Docket No. ER08-1317, 124 FERC ¶ 61,292 (2008) (initial order approving tariff reforms instituted as part of CAISO’s generator interconnection process reform); *order on reh’g*, 127 FERC ¶ 61,177 (2008); and 128 FERC ¶ 61,247 (2009) (order on compliance filing). The CAISO tariff also includes as Appendix U a separate set of Standard Large Generator Interconnection Procedures. Appendix U does not apply to interconnection requests in a queue cluster window and thus does not apply to this Agreement.

¹⁷ The original interconnection request to the CAISO was for 280 MW on a full-capacity deliverability basis, but was modified after the release of the CAISO’s Phase I Interconnection Study to be a request for 290 MW on an energy-only basis, as permitted under the CAISO LGIP. CAISO Appendix Y LGIP § 7.1 and Appendix 2 § 4.3.1.

¹⁸ A revised version of the facilities study was issued on May 18, 2010.

that time six of the twelve generators in the cluster group, representing two-thirds of the generation capacity, dropped out of the interconnection queue.

The CAISO issued its Phase II Interconnection Study for the Agua Caliente Solar Project on May 5, 2010, and concluded that the following facilities are required to interconnect the project and mitigate system impacts:

- Participating transmission owner's interconnection facilities – Extend generator tie from the point of interconnection at a new 500 kV switchyard between Hassayampa and North Gila to the participating transmission owner property line;
- Reliability network upgrades – Construct a new 500 kV switchyard and loop Hassayampa-North Gila line into the new 500 kV switchyard; and
- Deliverability network upgrades – None.¹⁹

The study also concluded that the Project proposed by NextLight may cause adverse impacts on IID's transmission system.²⁰ Thus, the IID transmission system was identified as an Affected System, and the Parties have included provisions in the Agreement to ensure that an Affected System study is performed and any adverse impacts on IID's Affected System resulting from the proposed interconnection are mitigated.²¹

In order to advance implementation of the interconnection of the Generating Facility while finalizing the Agreement, APS and NextLight executed an Engineering and Procurement ("E&P") Agreement, with the consent of SDG&E and IID, which the Commission accepted for filing on May 14, 2010.²² The E&P Agreement provides the terms and conditions under which APS, on behalf of itself, SDG&E, and IID, will begin to design, engineer and procure items associated with the interconnection of the NextLight facilities. Construction of such facilities will be governed by the instant Agreement.

II. THE AGREEMENT SHOULD BE ACCEPTED FOR FILING

The Commission has explained the standard for acceptance of non-conforming Large Generator Interconnection Agreements as follows:

¹⁹ California Independent System Operator Corp., *Phase II Interconnection Study Report, Appendix A - T468 Individual Project Report, NextLight Renewable Power, LLC, Agua Caliente Project, Final Report*, dated May 4, 2010, at 12 ("CAISO Phase II Report").

²⁰ *CAISO Phase II Report*, Appendix A at 2 (stating: "The Project may cause or exacerbate pre-Project overloads in IID's transmission system. Thus, the IID transmission system was identified as an Affected System. ... [I]mpacts to IID's transmission system need to be further investigated."). The Filing Parties have been informed by NextLight and IID that they intend to enter into an Affected System Study Agreement soon to further assess possible impacts on IID's transmission system.

²¹ See, e.g., Agreement § 11.4.4 – Special Provisions for Affected Systems.

²² *Arizona Public Service Co.*, Docket No. ER10-976-000, delegated letter order May 14, 2010.

At the same time, the Commission recognized in Order No. 2003 that there would *be a small number of extraordinary interconnections where reliability concerns, novel legal issues or other unique factors would call for the filing of a non-conforming agreement*. The Commission made clear that the filing party must clearly identify the portions of the interconnection agreement that differ from its *pro forma* agreement and explain why the unique circumstances of the interconnection require a non-conforming interconnection agreement. The Commission analyzes such non-conforming filings, which we do not expect to be common, to ensure that operational or other reasons necessitate the non-conforming provisions. A Transmission Provider seeking a case specific deviation from its approved *pro forma* interconnection agreement bears an even higher burden to explain what makes the interconnection unique and why its changes are operationally necessary (not merely “consistent with or superior to”) changes.

MidAmerican Energy Co., Docket No. ER06-966-000, 116 FERC ¶ 61,018 at ¶ 8 (2006) (“*MidAmerican*”) (emphasis added) (footnotes omitted). *See also Southern California Edison Co.*, Docket No. ER10-796, 131 FERC ¶ 61,071 at ¶¶ 26–27 (2010); *Southern California Edison Co.*, Docket No. ER10-732, 131 FERC ¶ 61,016 at ¶ 23 (2010).

The Filing Parties have prepared this filing under the assumption that every provision of the Agreement that is different from the APS LGIA or the CAISO LGIA may be reviewed by the Commission under the *MidAmerican* standard. Notwithstanding this burden, Filing Parties believe that the Agreement is one of the “small number of extraordinary interconnections where reliability concerns, novel legal issues or other unique factors would call for the filing of a non-conforming agreement.” *Id.*

In light of the unique legal context with regard to the rights and responsibilities concerning the Hassayampa-North Gila line, and the unique aspects of the interconnection requests to both APS and the CAISO, the Filing Parties had little choice but to develop an Agreement which is “non-conforming” to the applicable APS and CAISO LGIAs. As noted above, APS and CAISO are both FERC-jurisdictional transmission providers, with significantly different *pro forma* LGIAs.²³ Therefore, it is impossible for the Agreement to “conform” to both *pro forma* LGIAs. However, in many instances, deviations from the APS LGIA make the Agreement conform to, or be consistent with, provisions in the CAISO LGIA, which has been approved by the Commission.²⁴ Because these provisions have been approved for inclusion in the CAISO LGIA, they have already passed Commission review as just and reasonable and should be so considered in the circumstances presented here, as described in more detail below.

²³ See Attachment E (redline comparison of APS LGIA and CAISO LGIA).

²⁴ Order No. 2003 at ¶ 827; *California Indep. Sys. Operator Corp.*, 124 FERC ¶ 61,292 at ¶ 16.

The Agreement was drafted to accommodate differences between the APS and CAISO LGIAs for an “extraordinary interconnection” where “unique factors would call for the filing of a non-conforming agreement.” *MidAmerican* at ¶ 23. The Parties initiated drafting the joint Agreement using the APS LGIA as the base document, as it is in almost all respects the same as the FERC Order No. 2003 *pro forma* LGIA. Changes made to the APS LGIA are operationally necessary to address these unique factors:

- Significant differences between the *pro forma* large generator interconnection agreements of two of the transmission providers involved – namely, the APS LGIA and the CAISO LGIA;
- Joint ownership of the line by three utilities, APS, IID, and SDG&E, each of which has its own tariff;
- Operational responsibilities over portions of the line by two different entities, APS and the CAISO, both of which have their own tariffs;
- Joint ownership provisions that determine how capital improvements will be made, such as the building of a new switchyard on the JPP;
- Inclusion of IID as a non-FERC jurisdictional Party to the Agreement both in its capacity as a co-owner of the line and as the owner of an Affected System; and
- The use of solar photovoltaic technology, a generation technology that has never been used for a generating facility on the scale planned here and was not anticipated when the FERC Order 2003 *pro forma* LGIA, on which the APS LGIA is based, was developed.

In Order No. 2003-A, FERC recognized,

that issues will arise that are not covered by the LGIP and LGIA. When that happens, we expect the Parties to follow the spirit of Order No. 2003 and to deal with one another in good faith. Transmission Providers should not use the fact that the LGIP and LGIA do not explicitly cover a particular situation to delay or deny Interconnection Service.²⁵

In the spirit of Order No. 2003, the Parties to the Agreement did deal with one another in good faith to develop the Agreement the Filing Parties are submitting today.²⁶

Although the Agreement may be considered “non-conforming,” the Agreement accomplishes the objective FERC had in mind when it crafted the Order No. 2003 *pro forma* LGIA and LGIP – the facilitation of interconnection. In fact, the Filing Parties believe that the changes that have been made to the APS and CAISO LGIAs are not only

²⁵ Order No. 2003-A, 106 FERC ¶ 61,220 at ¶ 4.

²⁶ Notwithstanding the challenges of developing the Agreement for the Generating Facility, all Parties have executed the Agreement or, in the case of IID and SDG&E, have requested approval by their respective Boards to execute it.

necessary to address the unique circumstances of this generator interconnection, but also take a highly desirable comprehensive approach that more effectively facilitates interconnection of the Generating Facility than any *pro forma* agreement could have. In particular, through cooperation of the Filing Parties toward the common end of interconnecting the Generating Facility, the Agreement much more effectively establishes the rights and responsibilities of each of the multiple Parties necessary to the interconnection of the Generating Facility than would have been possible if the Interconnection Customer had been required to negotiate multiple agreements. Moreover, a single agreement is a desirable contractual vehicle under which to establish the legal rights and obligations of the Parties, and establishes contractual privity between all Parties.

In this section the Filing Parties will provide: (1) a summary of the major reasons that it has proven necessary for the Filing Parties to file a “non-conforming” Agreement; and (2) a subject-matter-by-subject-matter description of the most significant distinctions between the Agreement and the APS and CAISO LGIAs. A detailed article-by-article explanation of the differences between the Agreement and the APS and CAISO LGIAs is provided in Attachment A.

A. Overview of the Major Reasons for the Agreement’s Variations from the APS LGIA

The Filing Parties began their efforts using the APS LGIA (which is in almost all respects identical to the FERC Order No. 2003 *pro forma* LGIA) as the initial basis for the draft of the Agreement. It rapidly became clear, however, that it would have to be adapted to address the unique circumstances here. There are three principal ways in which this Agreement differs from the APS LGIA:

- The Agreement is more comprehensive than the APS LGIA since the Agreement was deliberately written to address project-specific aspects of the interconnection requests to multiple entities and to include all of the multiple transmission providers and transmission owners.
- The Agreement was deliberately written to be much more specific than the APS LGIA, principally because use of generic terms makes that LGIA too vague in light of the number of Parties involved, their potentially overlapping responsibilities, inclusion of IID as a non-jurisdictional Party, and the particularly separate treatment of the two phases of the Generating Facility.
- The Agreement was necessary to reconcile provisions of the APS LGIA with the CAISO LGIA, which differ from each other in several important ways.

Each of these major reasons for variation from the APS LGIA is explained in greater detail below.

B. Comprehensive Agreement

The APS LGIA is written in a way that assumes that there are two parties, an interconnection customer and a “Transmission Provider.” Similarly, the APS LGIA assumes that there is an interconnection to one “Transmission System,” and that a single “Transmission Provider” would have responsibility for interconnections to its own Transmission System. It assumes that a single “Transmission Provider” will be responsible for conducting studies, signing the LGIA, constructing the transmission owner interconnection facilities and network upgrades (assuming the “standard option” provided for in Article 5.1.1 is used), and operation and maintenance unless there also is another “Affected System.”

These assumptions simply do not fit the unusual facts and circumstances presented. With respect to this interconnection, four Parties – the three joint owners and the CAISO – are responsible for at least some of the functions ascribed to the “Transmission Provider” in the APS LGIA, and each has a distinct role to play with respect to the interconnection. Moreover, there are multiple transmission systems owned or operated by the respective Parties, including the jointly-owned JPP and other individually-owned transmission facilities. Therefore, it is important to clarify in the Agreement the definitions of “Transmission System” and “Affected System” under the particular circumstances presented here.

In order to craft an agreement to cover this situation, the Filing Parties agreed to draft a comprehensive Agreement which includes all of the necessary Parties, *i.e.* APS, SDG&E, CAISO, and IID, which is not a FERC-jurisdictional public utility. The Agreement comprehensively covers impacts on all of their transmission systems, whether jointly- or individually-owned, either by requiring the upgrades identified in Agreement Appendices providing for possible network upgrades that may be required on SDG&E’s system for Phase B, or by including provisions requiring separate Affected System Study and Affected System Construction and Operation Agreements with IID.²⁷ It even provides for possible future needs by including special conditions that will be triggered only if Phase B of the Generating Facility will be in the CAISO Balancing Authority Area.

The Filing Parties believe that this comprehensive approach is a desirable way to address the Interconnection Customer’s interconnection requests. By cooperating in developing the Agreement the Parties have avoided imposing potentially inconsistent obligations and put in place a coherent framework for coordination of the Parties’ respective roles and responsibilities for the life of the Agreement. Moreover, execution by all Parties of a single agreement places each Party in mutual contractual privity with each other.

²⁷ The FERC Order No. 2003 *pro forma* LGIA at Article 11.4.2, the CAISO Attachment Y LGIP at § 12.4, and the CAISO Attachment Z LGIA at Article 11.4.2 all require the Interconnection Customer to enter into agreements with Affected Systems, but do not require inclusion of an Affected System as a party to the LGIA.

C. Specific References

In light of the number of Parties and each of their transmission systems that might be affected by the interconnection requests, the Parties concluded it would be preferable to adopt the approach accepted by the Commission for the three-party CAISO LGIA using more specific references than in the APS LGIA in order for the intent of the Agreement to be clear. For example:

- Conforming to the CAISO LGIA, the term “Transmission Provider” was not used in the Agreement. Instead, the Agreement refers as appropriate to the “Transmission Owners” or names the specific Parties that are intended to have a particular right or responsibility that the APS LGIA more generically ascribes to a “Transmission Provider.”²⁸ Where the “Transmission Provider” role was changed in the CAISO LGIA to include only the transmission owner, the same change was made in this Agreement. Where the CAISO is assigned responsibility in the CAISO LGIA, a determination was made whether the CAISO should have similar responsibilities in this Agreement or whether APS would be the appropriate entity to assume the responsibilities as the operating agent for the transmission owners. It was also necessary to refer to the specific transmission owners or Parties, rather than simply to use the generic term “Transmission Provider” because, as defined by FERC in the Order No. 2003 *pro forma* LGIA, as well as in the APS LGIA, the term “Transmission Provider” means the “public utility that . . . provides transmission service under the Tariff.” Here, IID is not a public utility subject to FERC jurisdiction under Sections 205 and 206 of the FPA. Moreover, there are multiple Parties with multiple tariffs under which each provides its respective services.
- With respect to the term “Transmission System,” while the term is used when appropriate, in many cases it has been replaced with references to discrete parts of the transmission system, such as the “Joint Participation Project” or “JPP” for the jointly owned line, SDG&E’s non-JPP transmission system, and IID’s non-JPP transmission system. The CAISO LGIA also uses terms other than “Transmission System” to refer to elements of the transmission system described in the CAISO LGIA. However, many of the references in the Agreement are variances from both the APS LGIA and the CAISO LGIA that are necessary to address the special circumstances of the multi-Party ownership of some affected facilities and potentially individual Party ownership of others.

²⁸ The Filing Parties recognize that in the FERC Order No. 2003 *pro forma* LGIA, the term “Transmission Provider” includes “Transmission Owners.” But, FERC did indicate that “With respect to concerns raised about the rights and responsibilities of the Transmission Provider and Transmission Owner not being spelled out in the LGIA, the independent entity variation gives RTOs and ISOs broad discretion in the final design of their LGIP and LGIA, and we encourage each RTO or ISO to spell out such rights and responsibilities in its compliance filing.” Order No. 2003-A at ¶ 87. As such, in the CAISO LGIA the term “Transmission Provider” was changed to assign responsibilities to the “Participating Transmission Owner,” to the CAISO, or to both, as appropriate to the particular provision.

- With respect to the Generating Facility, when appropriate, the Agreement refers to its components, Phase A of the Generating Facility, and Phase B of the Generating Facility. In many instances, this is a variance from both the APS LGIA and the CAISO LGIA that is necessary to address the special circumstances of the particularly separate treatment of the two phases of the Generating Facility in the Agreement.

D. Reconciliation of APS and CAISO LGIA Provisions

A challenge the Parties faced in developing the Agreement was the need to reconcile the APS LGIA (which is in almost all respects identical to the FERC Order No. 2003 *pro forma* LGIA) and the CAISO LGIA. There are significant differences between the FERC Order No. 2003 *pro forma* LGIA, and the LGIA that CAISO has crafted for inclusion in its tariff. Moreover, recently the CAISO went through a generator interconnection process reform and sought FERC approval for significant changes to the CAISO LGIP and LGIA, particularly with respect to the interconnection study process, posting of “Interconnection Financial Security,” as defined in the CAISO LGIP, and payment for the cost of network upgrades.

With respect to the Agreement, in some cases it was possible to accommodate the requirements of both the APS LGIA and the CAISO LGIA by having the new CAISO requirements apply only to the Interconnection Customer’s relationship with SDG&E. But, in some instances it was necessary to reconcile the differences, which was usually done by having the Parties agree that the more stringent provision would apply to this interconnection. Another fundamental aspect of this reconciliation is the omission from this Agreement of the provisions of Articles 3.2, 3.3, and 3.4 of the CAISO LGIA that provide that the CAISO LGIA is governed by and subject to the CAISO tariff. Rather than incorporate these more general provisions that would not appropriately apply to APS and IID, the CAISO has undertaken to incorporate references to specific provisions of the CAISO tariff that apply in particular provisions of the Agreement to this interconnection. How the Agreement addresses each of the other differences between the APS and CAISO LGIAs is explained in Part III and Attachment A.

III. EXPLANATION OF KEY DIFFERENCES BETWEEN THE APS LGIA, THE CAISO LGIA, AND THE AGREEMENT BY TOPIC

A. Interconnection Service

Article 4.1 of the APS LGIA provides the Interconnection Customer with the option of selecting energy resource interconnection service or network resource interconnection service. The CAISO offers only one kind of “interconnection service;” accordingly, the CAISO LGIA provides for only one option. *See California Independent System Operator*, ER04-445, 112 FERC ¶ 61,009 at ¶ 44 (accepting CAISO tariff provision which provides only one kind of interconnection service). The CAISO, however, offers

two options for deliverability status, full capacity and energy-only, whereas APS does not offer deliverability status options.²⁹

As a result of these differences, it was necessary to reconcile the provisions. Under Article 4.1.1 of the Agreement, CAISO will provide “interconnection service,” consistent with its tariff. The interconnection request made to APS is for energy resource interconnection service. Therefore, Article 4.1.2 of the Agreement provides that transmission owners APS and IID will provide energy resource interconnection service for this interconnection to the jointly-owned line.³⁰

Article 4.2 - Provision of Service, has been modified to make clear that the transmission owners and the CAISO all be providing interconnection service at the point of interconnection. This is consistent with their shared role in providing service over the Hassayampa-North Gila line.

B. Election of Balancing Authority

Article 9.2 of the APS and CAISO LGIAs provides that at least three months before the initial synchronization date the Interconnection Customer shall notify the transmission provider of its intended “control area” (now known as “Balancing Authority Area,” as set forth in the CAISO LGIA). Any necessary arrangements are to be made prior to placing the Generating Facility in service in the Balancing Authority Area. Article 9.4 further provides that the Interconnection Customer is to follow all requirements of the Balancing Authority Area and that details are to be set forth in Appendix C.

For this Agreement it was necessary to alter the way in which the APS LGIA handles election of the Balancing Authority Area and Balancing Authority Area operating responsibilities. The Generating Facility is located near the boundary of the APS and CAISO Balancing Authority Areas and, therefore, the Parties anticipate that it could feasibly be located “within” either of the Balancing Authority Areas, given the possibility that it could be a pseudo-tie out of its native CAISO Balancing Authority Area. The Interconnection Customer has made it clear it will select the CAISO Balancing Authority Area for Phase A of the Generating Facility and, as noted, made an interconnection request to the CAISO for 290 MW of the planned 500 MW. At this time, it is not clear

²⁹ Provisions of the CAISO LGIP which give the Interconnection Customer a choice of deliverability status include CAISO LGIP § 3.5.1, Initiating an Interconnection Request, and CAISO LGIP Appendix A, Large Generator Interconnection Study Process Agreement (study process agreement). The former provision states that an interconnection customer must specify requested deliverability status in the study process agreement, while the latter provision offers the choice between full capacity and energy-only under deliverability status.

³⁰ See Agreement, Article 4.1.2. Article 4.1.2 of the Agreement is the analog to Article 4.1.1 of the APS LGIA, which provides for energy resource interconnection service. The Interconnection Customer did not request network resource interconnection service. Accordingly, the Article in the APS Attachment O relating to network resource interconnection service (Article 4.1.2 of the APS LGIA) is shown as “not applicable” in the Agreement at Article 4.1.3.

whether the Interconnection Customer will elect the CAISO Balancing Authority Area for Phase B of the Generating Facility, which will be for the remaining 210 MW.

Given the Interconnection Customer's election as to Phase A, the Agreement specifies that the CAISO tariff provisions relating to Balancing Authority functions apply to this phase of the Generating Facility. The Agreement preserves the Interconnection Customer's right to select the Balancing Authority Area for Phase B of the Generating Facility at a later point in time, in the same manner contemplated by the APS LGIA and the CAISO LGIA. Language was added to the Agreement that prescribes the relevant responsibilities for APS or the CAISO, depending on which is selected as the Balancing Authority Area for a given phase.

The modifications to the Agreement to reflect that the Interconnection Customer has already elected the CAISO to be the Balancing Authority for Phase A, but has not yet made an election for Phase B, are described below.

- **Article 7- Metering.** The article was modified to include both the APS LGIA language and a new provision, Article 7.6, which will make the CAISO metering requirements applicable for a project phase if the Interconnection Customer selects the CAISO as the Balancing Authority Area for that project phase.
- **Article 8 - Communications.** This article was also written to include both the APS LGIA language and a new provision, Article 8.4, which will make the CAISO communications requirements applicable for a project phase if the Interconnection Customer selects the CAISO as the Balancing Authority Area for that project phase.²¹
- **Article 9.2 - Balancing Authority Area Notification, and Article 9.4 – Interconnection Customer Obligations.** These Articles were modified to update the term “Control Area” to “Balancing Authority Area,” consistent with the CAISO LGIA [Articles 9.2 and 9.4], and to make it clear that the Interconnection Customer shall provide separate notifications of election of Balancing Authority Area for each project phase [Article 9.2]. In addition, the CAISO LGIA provision of Article 9.4 requiring written approval of the transmission owner prior to commercial operation of the Generating Facility was omitted as such approval is covered by other provisions of the Agreement.

C. Outages and Emergencies

The Parties made various modifications to the operations sections of the APS and CAISO LGIAs relating to outages and emergencies in order to clarify the operational

²¹ Article 8.1 - Interconnection Customer Obligations - requires the Interconnection Customer to provide certain dedicated data to circuits in accordance with details set forth in Appendix D, Security Arrangements Details. The CAISO LGIA version of Appendix D has additional details beyond those in the APS LGIA Appendix D. Thus, Appendix D was modified to provide that if the Interconnection Customer chooses the CAISO as the Balancing Authority for a project phase, it must comply with the additional requirements included in the CAISO LGIA version of Appendix D.

responsibilities of APS and the CAISO with respect to the JPP and the Generating Facility. The Parties agreed to terms in the Agreement that respect the roles of both APS and the CAISO and require coordination as appropriate:

- **Article 9.7.1.1 - Outage Authority and Coordination, Article 9.7.1.2 - Outage Schedules, and Article 9.7.2 - Interruption of Service.** These articles were modified to make clear that for any project phase in the CAISO Balancing Authority Area, both APS and the CAISO will have a role. Specifically:
 - **Article 9.7.1.1 - Outage Authority and Coordination** - was modified to provide that for any project phase in the CAISO Balancing Authority Area, the Interconnection Customer shall be required to coordinate not only with APS, but also with the CAISO in accordance with the CAISO tariff, and to require APS to coordinate with the CAISO.
 - **Article 9.7.1.2 - Outage Schedules** - was modified to provide that for any project phase in the CAISO Balancing Authority Area, the Interconnection Customer shall be required to submit outage schedules not only to APS, but to the CAISO in accordance with the CAISO tariff. The Article further provides that APS, on behalf of all of the transmission owners, and CAISO shall each have authority to request rescheduling of planned outages by the Interconnection Customer, and that the Interconnection Customer may receive compensation from either APS or the CAISO and that compensation from the CAISO will be in accordance with its tariff if CAISO requests rescheduling. The Article also provides that provisions governing rescheduling of planned outages by the Interconnection Customer are subject to the CAISO tariff as they pertain to the CAISO, consistent with the CAISO LGIA.
 - **Article 9.7.2 - Interruption of Service** - was modified to provide that APS will have authority on behalf of the transmission owners, to require Interconnection Customer to interrupt or reduce its deliveries of electricity and that for any project phase in the CAISO Balancing Authority Area, in addition to APS, the CAISO shall also have authority to require such interruptions of service in accordance with the CAISO tariff.
- **Article 13 - Emergencies**
 - **Article 13.2 - Obligations** - was modified to clarify the responsibilities of the Parties to comply with emergency condition procedures.
 - **Article 13.3 - Notice** - was modified to make clear that both the transmission owners and the CAISO shall provide and receive notices of emergency conditions.
 - **Article 13.4 - Immediate Action** - was modified to make clear that the Interconnection Customer is to attempt to obtain consent from both APS and the CAISO before taking immediate action to address an emergency declared by APS or by the CAISO.

- **Article 13.5.1**, which relates to emergencies, was modified to provide that both the transmission owners and the CAISO shall have authority to respond to emergencies.
- **Article 13.5.2 - Reduction and Disconnection** - was modified to provide that both APS, on behalf of the transmission owners, and the CAISO shall have authority to reduce interconnection services or order disconnection in the event of emergencies.

D. Generating Technology

Some modifications were made to the APS and CAISO LGIAs because the provisions were not written with a particular generating technology in mind. The Generating Facility will be one of the first to use solar photovoltaic technology on a large scale. FERC acknowledged that modification of its Order No. 2003 *pro forma* LGIA language might be necessary for newer technologies when it stated:

We recognize that the LGIA and LGIP are designed around the needs of large synchronous generators and that many generators relying on newer technologies may find that either a specific requirement is inapplicable or that it calls for a slightly different approach.

Order 2003-A at ¶ 407 n. 85.

Two types of modifications were made to address the use of solar photovoltaic technology: (1) those that relate to the build out of the Generating Facility; and (2) those that relate to the Applicable Reliability Standards under the Agreement.

1. Build-Out of the Generating Facility

FERC drafted the *pro forma* LGIA in a way that assumes all or virtually all of the generating capacity comes on line at once. That is not generally the case for facilities using solar photovoltaic technology since such facilities are modular and built incrementally with the addition of project blocks over many months.

The CAISO has modified its LGIP to permit the Interconnection Customer to establish an implementation plan that includes different phases for commercial operation of a generating facility:

[W]here an Interconnection Customer intends to establish Commercial Operation separately for different Electric Generating Units or project phases at its Generating Facility, it may only do so in accordance with an implementation plan agreed to in advance by the CAISO and Participating TO, which agreement shall not be unreasonably withheld.

CAISO LGIP § 6.7.1.

In addition, in the CAISO LGIA, the CAISO has modified the terms “Commercial Operation” and “Commercial Operation Date” in a way that recognizes that a project can be implemented in phases. *See* CAISO LGIA Article 1.

Consistent with the CAISO’s approach, the Agreement incorporates references to “Project Blocks,” a new term used in this Agreement for the 1-2 MW units which will gradually be added to the Generating Facility after the initial synchronization date. In Appendices B-1 and B-2 the expected implementation plan is briefly described and provisions are included which require the Parties to work together to develop a more detailed implementation plan. These provisions are necessary to reflect the unique nature of the Generating Facility, and the fact that the bringing a facility using photovoltaic technology online does not neatly fit into the language developed in Order No. 2003.

The definitions of “Commercial Operation” and “Commercial Operation Date” were also modified in light of the generating technology. Under the Agreement, individual Project Blocks may be in “Commercial Operation,” but the “Commercial Operation Date” will not occur for Phase A of the Generating Facility until *all* the Project Blocks for that phase are installed. Likewise, the “Commercial Operation Date” for Phase B of the Generation Facility will not occur until all Project Blocks for that phase are installed.

2. “Applicable Reliability Standards” under the Agreement

The Agreement defines “Applicable Reliability Standards” as the requirements and guidelines of NERC, the Applicable Reliability Council [*i.e.*, the Western Electricity Coordinating Council], and the applicable Balancing Authority.³² The Parties have made a limited number of revisions to the APS and CAISO LGIAs relating to reliability, based on the particular technology used for the Generating Facility. Both APS and the CAISO performed interconnection studies which took into account the electrical characteristics of solar photovoltaic technology and both concluded that if the Generating Facility is built in accordance with the design studied the Generating Facility will meet the Applicable Reliability Standards.

As FERC recently recognized, its Order No. 2003 *pro forma* LGIA has not been modified to address the special characteristics of solar photovoltaic facilities as it was for generating facilities using wind technology by adopting Orders 661 and 661-A.³³ In *Nevada Power*, FERC agreed with NextLight that it would not be appropriate to consider making significant policy changes in a docket that will only address one LGIA.³⁴

³² As used herein, the term “Applicable Reliability Standards” shall have the same meaning as set forth in the Agreement.

³³ *Nevada Power Co.*, Docket No. ER10-508-000, 130 FERC ¶ 61,147 at ¶ 23 (2010) (“*Nevada Power*”).

³⁴ *Id.* at ¶ 24 (“We agree with Nevada Power and NextLight that this is not the appropriate proceeding in which to make a generic determination on whether to extend to solar generators wind power’s exemption from the requirement to provide reactive power support.”).

Similarly, the Filing Parties request acceptance in this docket of proposed language that differs from the APS and CAISO LGIAs only to the extent necessary to accept this Agreement. The Filing Parties do not request any generic determinations with respect to the Commission's generator interconnection policy regarding solar photovoltaic generating facilities.

In the Agreement, the Parties have updated some provisions to take into account the need to comply with "Applicable Reliability Standards," as defined in the Agreement. Other changes were made to reconcile the provisions in the APS LGIA and the CAISO LGIA. In particular, the most important changes to the APS and CAISO LGIAs that were made are:

- **Article 5.4 - Power System Stabilizers.** This provision includes some changes that are slightly different from but consistent with the CAISO LGIA. In particular, CAISO LGIA references to "Applicable Reliability Standards" and CAISO LGIA provisions to address malfunctions were incorporated. To mirror Order No. 2003-A's inclusion of an exception for wind generators since wind generator do not have power system stabilizers, *see* Order 2003-A at ¶ 280 and appended *pro forma* LGIA at § 5.4, the Parties have added new language at the end of the article which makes it clear that solar photovoltaic generators do not have power system stabilizers. This is very similar to the approach used by the parties to the agreement FERC accepted for filing in *Nevada Power*.
- **Article 9.6.1 - Power Factor Design Criteria.** This provision follows the APS LGIA with respect to Phase A of the Generating Facility, rather than the inconsistent CAISO LGIA provisions, and expressly indicates that the power factor criteria in the Agreement will supersede the criteria in the CAISO tariff, which are different. For Phase B of the Generating Facility, the Agreement provides that either the same power factor criteria or the Applicable Reliability Standard at the time of any additional CAISO studies for Phase B of the Generating Facility will be used. Thus, if changes are made soon to the power factor criteria for solar photovoltaic generating facilities, they could apply to Phase B of the Generating Facility.
- **Article 9.6.2 - Voltage Schedules.** The APS LGIA provision was modified to make clear that APS will be responsible for compliance with Applicable Reliability Standards related to reactive power and voltage support, subject to any separate agreement APS and the CAISO may enter into regarding compliance with these standards. Additional provisions were added to the APS and CAISO LGIAs to make clear that in determining the operational requirements for reactive power and voltage support APS will use the data that was provided for the interconnection studies.
- **Article 9.6.2.1 - Governors and Regulators.** Currently solar photovoltaic generators equipped with governors and regulators are not commercially available. The APS and CAISO LGIA provisions were modified to make clear that the Interconnection Customer shall procure, install, and maintain governors and regulators to the extent required by Applicable Reliability Standards. The CAISO

LGIA provisions relating to malfunctions were also incorporated into the language with respect to how governors and regulators would be operated.

- **Article 9.6.3 - Payments for Reactive Power and Article 11.6 - Interconnection Customer Compensation.** Because the Generating Facility will use solar photovoltaic generating technology, its ability to provide reactive power is very limited. Nonetheless, the provision in the APS LGIA relating to payments for reactive power in Article 9.6.3 was not substantively modified and the responsibility for any payments was assigned to APS as the entity responsible for reactive power and not to the CAISO. However, Article 11.6 refers specifically to payments made for reactive power under Article 9.6.3 and specifies how compensation for emergency services will be provided. Thus, in Article 11.6 the Parties eliminated the reference to payments for reactive power pursuant to Article 9.6.3 (since this avoided having to agree to terms regarding compensation for reactive power) but retained the portion of this provision relating to payment for emergency services.

E. Financial Matters

Many of the APS and CAISO LGIA terms relating to financial matters, such as those relating to financial security, termination costs, allocation of cost of network upgrades, and reimbursement for cost of network upgrades, were modified in the Agreement. These modifications were necessary because the JPP is a jointly-owned line, with one of the joint owners, SDG&E, subject to the CAISO requirements, and the others subject to other requirements. In addition, there are significant differences between the APS and CAISO LGIA provisions with respect to how these subjects are addressed.

1. Financial Security and Termination Costs

Under the APS LGIA, interconnection customers are not required to post security until an LGIA is signed, and the primary purpose of posting security is to ensure that funds are available to the transmission provider to cover termination costs.

The provisions of the CAISO LGIP and LGIA were substantially changed recently as a result of the CAISO's generator interconnection process reform.³⁵ An important part of the CAISO's reforms was to increase the financial commitments of generators during the interconnection process as a means to ensure that only the most financially viable projects advance through the new CAISO cluster study process.³⁶ Thus, after the results of the Phase I Interconnection Study are released, the CAISO LGIP requires the posting

³⁵ The objectives of the CAISO reforms are explained in the FERC orders in which the tariff changes were accepted. See *California Indep. Sys. Operator Corp.*, Docket No. ER08-1317, 124 FERC ¶ 61,292 (2008) (initial order approving tariff reforms instituted as part of CAISO's generator interconnection process reform) and 128 FERC ¶ 61,247 (2009) (order on compliance filing).

³⁶ See generally *California Indep. Sys. Operator Corp.*, Docket No. ER08-1317, 124 FERC ¶ 61,292 at ¶¶ 51-61 (FERC discussion of reasons for finding CAISO's proposed tariff provisions relating to Interconnection Financial Security just and reasonable).

of what is known as “Interconnection Financial Security” in order for an interconnection request to be analyzed in the Phase II Interconnection Study process. CAISO LGIP § 9.2.³⁷ Additional Interconnection Financial Security must be posted within 180 days of the release of Phase II Interconnection Study results and all Interconnection Financial Security must be posted before construction activities begin. CAISO LGIP § 9.3. Interconnection Financial Security is held by the utilities, not by the CAISO.

Under the CAISO LGIP, like the APS LGIA, the security that is posted can be used to cover termination costs. Unlike the APS LGIA, however, the CAISO Interconnection Financial Security is at least in part an “earnest money” requirement, and, under certain circumstances, it may be forfeited even when it is not needed to cover termination costs. CAISO LGIP § 9.4.

Because of the fundamentally different purposes for the holding of security, the Parties decided that rather than attempt to reconcile the financial security and termination cost provisions, they would use the applicable financial security requirements for each of the joint owners. Thus, the Agreement has been crafted such that the APS financial security and termination cost provisions are to apply to security held by APS, on behalf of both APS and IID, and the CAISO LGIP and LGIA provisions relating to Interconnection Financial Security and termination costs apply to SDG&E. Specifically:

- **Article 2.4 - Termination Costs:** This provision was substantially modified. While the APS LGIA provision is relatively simple, the CAISO has greatly expanded this provision, so it formed the basis for this provision of the Agreement. The provision was written to require APS, as the Operating Agent of the JPP, to enforce the security rights of APS and IID to cover their shares of termination costs and to permit SDG&E to enforce its rights to termination costs in accordance with the requirements of the CAISO tariff. By making SDG&E manage the Interconnection Financial Security in a manner consistent with the CAISO LGIP and, in particular, Section 9.4 of the CAISO LGIP, the Parties have ensured that the CAISO’s use of the Interconnection Financial Security as “earnest money” that is potentially subject to forfeiture will be preserved.
- **Article 11.5 - Provision of Security:** This provision was also substantially modified. While it includes much of the APS LGIA language, it was necessary to make substantial additions to the APS LGIA text in order to make it clear that under the Agreement, APS, as the Operating Agent of the JPP, will be holding financial security to cover the APS and IID ownership shares and SDG&E will be holding Interconnection Financial Security for the SDG&E ownership share in accordance with the requirements of the CAISO tariff. The article also expressly provides that SDG&E can use the Interconnection Financial Security to provide for costs incurred by the other transmission owners since APS, as operating agent for the Joint

³⁷ As explained in Agreement Appendix A-1, Section 14(c), to satisfy this requirement, two letters of credit were posted with SDG&E: one for \$5.8 million for the cost of network upgrades and another for \$228,600 for the cost of transmission owner interconnection facilities.

Participation Project, will be the Party to the Agreement facing most, if not all, the financial exposure even though SDG&E, by virtue of its majority ownership in the joint facilities, will be holding most of the financial security. Additional details regarding the intent of the Parties with respect to financial security are provided in Agreement Appendices A-1, Section 14, and A-2, Section 13. In addition, the provisions of Section 16 of Appendix A-1 make clear that financial security requirements will be based on construction costs estimates of APS as the constructing utility, rather than on the cost estimates in the CAISO's Phase II Interconnection Study, as would otherwise be required by the CAISO LGIA.

2. Allocation of Cost of Network Upgrades

The APS LGIA assumes an interconnection customer will pay its allocated share of the cost of the network upgrades, which in this case would be the entire cost of such network upgrades.

As a result of the CAISO's generator interconnection process reforms, the CAISO now requires clustering and allocates the cost of network upgrades among the members of an identified cluster group and caps such costs on the basis of the lesser of the amounts identified in the results of its Phase I and Phase II Interconnection Studies. *See* CAISO LGIP § 12.3.1.³⁸

As a practical matter, the CAISO's new provisions relating to allocation of network upgrades costs will not have an effect on the Interconnection Customer with regard to Phase A of the Generating Facility. The CAISO Phase II Interconnection Study allocated 100% of the cost of the transmission owner interconnection facilities and network upgrades to the Interconnection Customer. There are no other generators in this cluster group that are attempting to use the same point of interconnection. Consequently, certain CAISO LGIA provisions that address sharing of costs of network upgrades among members of a cluster group have been omitted from the Agreement.

In the Agreement there are places in which the CAISO LGIA provisions regarding allocation of network upgrade costs have been incorporated rather than the provisions of the APS LGIA. For instance:

- **Article 5.16 - Suspension.** The first paragraph of this article limits the ability to suspend a project if the cost of network upgrades is being shared by multiple generators. This conforms to the CAISO LGIA.

³⁸ *See California Indep. Sys. Operator Corp.*, Docket No. ER08-1317, 124 FERC ¶ 61,292 at ¶ 176 (“We find that a fundamental change to current CAISO interconnection provisions exists in the cost allocation policy under the GIPR proposal. We find that pursuant to the GIPR LGIP, estimates of each interconnection customer’s cost responsibility for network upgrades determined in the Phase I Interconnection Study will serve as the maximum cost responsibility for network upgrades assigned to each interconnection request.”).

- **Article 11.3 - Network Upgrades and Distribution Upgrades.** This article incorporates clarifications from the CAISO LGIA that the methodology that SDG&E uses to allocate the cost of network upgrades is set forth in the CAISO LGIP.

3. Invoices

The APS LGIA invoicing provisions in Article 12 assume that only one transmission provider will be providing invoices under the Agreement. But, as explained earlier, the Parties have written the Agreement to be comprehensive enough to cover possible future contingencies. To that end, the invoice provisions have been revised in order to accommodate the possibility that SDG&E may need to build its own network upgrades to interconnect Phase B of the Generating Facility. Accordingly the Agreement provides for separate invoicing by SDG&E for its non-JPP network upgrades. Specifically:

- **Article 12.1 - General.** This Article was modified to provide for the possibility that APS, as operating agent, will be submitting invoices to the Interconnection Customer for the JPP and SDG&E will be submitting invoices for upgrades to portions of its Transmission System that are not a part of the JPP in accordance with the CAISO tariff.
- **Article 12.2 - Final Invoice.** This Article was modified to provide for the possibility that APS, as operating agent, will be submitting a final invoice to the Interconnection Customer for the Joint Participation Project and SDG&E will be submitting a final invoice for upgrades to portions of its Transmission System that are not a part of the JPP in accordance with the CAISO tariff.

With respect to the invoices provided by APS, this Article incorporates CAISO LGIA provisions providing for the possibility that the final invoice will show that the Interconnection Customer has underpaid, which provisions are not included in the APS LGIA.

With respect to invoices provided by SDG&E, this Article also includes language consistent with the CAISO LGIA.

- **Article 12.4 - Disputes.** This Article includes language that billing disputes will be resolved in accordance with the disputes resolution Article of the Agreement, which conforms to the CAISO LGIA.

4. Repayment for Cost of Network Upgrades

With respect to repayment for the cost of network upgrades, the Parties have agreed that reimbursement will be handled in a manner that is consistent with FERC's approach in Order Nos. 2003, *et al.* But, the APS LGIA was substantially modified since repayment will be made directly by three different transmission owners, each of which has different repayment obligations. Thus, the articles have been modified to state the obligations for repayment of the cost of network upgrades separately for each transmission owner which

are found in Articles 11.4.1 (APS), 11.4.2 (SDG&E), and 11.4.3 (IID). This is consistent with the approach that FERC suggested for repayment of the cost of network upgrades.³⁹

In addition to modifying the repayment provisions to provide for separate repayment by each of the transmission owners, it was necessary to make a few modifications to take into account the phasing of the project and changes to the term “Commercial Operation Date” consistent with the CAISO LGIA. As previously discussed in Section III.D.1, the Parties have modified the definition of the term “Commercial Operation Date” in this Agreement to clarify that this will not occur until all Project Blocks are installed for a project phase.

The articles of the Agreement relating to repayment of the cost of network upgrades are further explained below:

- **Article 11.4.1 - Repayment of Amounts Advanced to APS for Network Upgrades to APS’s Share of the JPP.** With respect to APS, the repayment obligations are those stated in the APS LGIA. Thus, the primary modifications to this Article reflect the agreement of the Parties to make it clear that repayment obligations will commence at the end of each project phase.
- **Article 11.4.2 - Repayment of Amounts Advanced to SDG&E for Network Upgrades to Its Share of the JPP and to Its Non-JPP Facilities.** With respect to SDG&E, the repayment obligations are those stated in the CAISO LGIA, although the language has been modified to take into account the phasing of the project. While the CAISO LGIA otherwise requires the commercial operation of all phases of a Generating Facility prior to commencement of the repayment obligation, the CAISO considers the provisions for repayment upon commercial operation of each of the two very separate project phases in this Agreement to be justified by the special circumstances of this facility. This is particularly the case because the CAISO has not yet received an interconnection request for Phase B; consequently the CAISO has no current basis for linking the repayment obligation for Phase A to the commercial operation of Phase B, in addition to which the Agreement provides the opportunity for the Interconnection Customer to terminate Phase B or move it to a separate LGIA, which would eliminate any basis for linking the repayment obligation. SDG&E’s repayment obligations extend not only to the SDG&E share of the transmission owner interconnection facilities and network upgrades for the Joint Participation Project, but also to possible upgrades to its individual transmission system that might be required for Phase B of the Generating Facility.

³⁹ See Order 2003-C, 111 FERC ¶ 61,401, at ¶ 18 (2005) (“Each owner of a jointly-owned system has the financial responsibility under its own Commission-regulated tariff to provide transmission credits and final reimbursement to the Interconnection Customer for the upfront payments that the owner has received. This responsibility does not extend to a non-public utility transmission owner or operator, of course.”).

Since SDG&E has a long-standing policy of repaying the cost of network upgrades in cash immediately after the Commercial Operation Date, provisions have been added to Appendix A-1 to make clear when SDG&E will be providing repayment.

- **Article 11.4.3 - Repayment of Amounts Advanced to IID for Network Upgrades to IID's Share of the JPP.** Since IID is a non-jurisdictional entity, its repayment obligations differ from those of APS and SDG&E. Thus, this provision differs from the language in Articles 11.4.1 and 11.4.2, based on the APS LGIA and the CAISO LGIA, respectively. As explained in Article 11.4.3, FERC has ruled that the obligation to provide transmission credits, under Section 205 or 206 of the FPA, does not apply to non-jurisdictional entities such as IID.⁴⁰ IID has nonetheless voluntarily agreed to provide transmission rate credits and to permit the Interconnection Customer to assign the rights to such transmission credits in accordance with the terms of the Agreement.

F. Interconnection Customer

1. Assignment of Interconnection Request to Two Financing Subsidiaries for Two Phases

As detailed above, NextLight submitted the original interconnection requests to APS and the CAISO. It subsequently assigned its rights, title and interest to Agua Caliente and North Gila for Phases A and B of the Generating Facility, respectively. These assignments were in aid of financing as well as to address the likelihood that Agua Caliente and North Gila will likely have very different development timelines and operations. In particular, Agua Caliente has already secured an off-take arrangement with PG&E, which, subject to approval by the California Public Utilities Commission, will result in the sale of all 290 MW of Phase A of the project into the CAISO. As noted, Agua Caliente has therefore elected to utilize the CAISO as its Balancing Authority. By contrast, North Gila does not yet have any off-take arrangement for its projected 210 MW of output. Depending on whom the purchaser is, North Gila may elect to be located in a different Balancing Authority than Agua Caliente. The two project companies enable the financing and operational flexibility required for the commercial development of the Generating Facility.

Although Agua Caliente and North Gila are separate companies, Appendix C, Section 6, provides that the two companies shall appoint a single spokesperson who shall serve as the Interconnection Customer's authorized agent and representative for purposes of administering the Agreement.

⁴⁰ See Order No. 2003-C, 111 FERC ¶ 61,401, at ¶ 18(2005) (*citing* Order 2003, 104 FERC ¶ 61,103, at ¶ 843 (2003)).

2. Special Provisions Needed to Accommodate Assignment to Two Companies

A number of changes from the APS and CAISO LGIAs were required to accommodate having an Interconnection Customer comprised of two entities. These include the following:

- **Article 2.3.1 - Written Notice.** This provision has been revised to require that both entities comprising the Interconnection Customer must provide written notice in order to terminate the Agreement. This was necessary to ensure that neither project company can jeopardize the interconnection rights of the other. This provision contains an exception to this rule with regard to the termination of the Agreement as it relates to Phase B and permits North Gila to terminate its obligations. This exception is contained in Appendix C, Section 8 (discussed below).
- **Article 2.5 - Disconnection.** This provision has been revised to provide for separate disconnection procedures for Phase A and Phase B of the Generating Facility.
- **Article 17.1.1 - [relating to default].** For purposes of the Agreement, there is but one Interconnection Customer. Nonetheless, for the avoidance of any doubt, the Agreement makes clear that in the event of any default by either project company, Agua Caliente or North Gila, has the right to assume the obligations of the other project company and the non-breaching Party is obliged to accept performance from the Interconnection Customer entity to the extent it continues to perform under the Agreement.
- **Article 30.13 - Joint and Several Obligations and Appendix C, Section 5.** The Agreement contains the CAISO LGIA joint and several obligations language, noting that liability is several and neither joint nor joint and several among the Parties to the Agreement. However, because there are two Parties that comprise the Interconnection Customer, this provision has been modified by reference in Appendix C, Section 5 with language making clear that as between Agua Caliente and North Gila, the obligations in the Agreement are joint and several. Appendix C, Section 7 provides that the joint and several obligations terminate in the event the Agreement is bifurcated as provided in Appendix C, Section 7 (see below).

G. Special Provisions Relating to Phase B of the Generating Facility

1. Possible Additional Studies for Phase B

Appendix C contains certain conditions that apply when the Interconnection Customer elects the Balancing Authority Area for Phase B of the Generating Facility. As noted, the Interconnection Customer has made an interconnection request to the CAISO for Phase A, whereas its interconnection request to APS was for the full 500 MW (Phases A and B). Consequently, the CAISO has never studied the system impacts of Phase B, nor has IID. To address this issue, the Parties agreed that CAISO and IID will review available studies and may request additional studies following the Interconnection Customer's

election of the Balancing Authority Area in which Phase B of the Generating Facility will be located.

Given the Parties' desire to put in place a comprehensive agreement, they agreed to structure the Agreement to accommodate any additional network upgrades that might be identified as a result of the possible additional CAISO studies associated with Phase B. With respect to possible network upgrades to the transmission system operated by the CAISO, if any such network upgrades are identified, based on the studies already conducted, such upgrades, if any, are anticipated to be on the portions of the SDG&E transmission system that are not part of the JPP. However, until the additional CAISO studies are completed, the possibility remains that those studies might identify additional network upgrades on the JPP. Thus, throughout the Agreement provisions have been included to provide for possible network upgrades to the SDG&E system or the JPP, including the addition of placeholder Appendices A-3 and B-3 and conditional provisions of Appendices A-2 and B-2, which will, to the extent applicable, identify any such upgrades.

With respect to possible IID network upgrades related to Phase B of the Generating Facility, the Agreement provides in Appendix C, Section 4, that the Interconnection Customer and IID will enter into an Affected System Construction and Operation Agreement if IID's studies find that any such upgrades are required.

2. Possible Separate Agreement for Phase B if Necessary for Financing Purposes

Given the differing obligations on and circumstances surrounding the two phases of Generating Facility, North Gila's financing of Phase B may necessitate bifurcating the Agreement into two separate LGIAs that are substantially similar in all material relevant respects to the original Agreement. In Appendix C, Section 7, the Agreement provides a mechanism for accomplishing this by requiring that the Parties amend the Agreement so as to enter into two LGIAs. As noted, in that event, Agua Caliente and North Gila would no longer have joint and several liability for one another's actions and obligations.

3. Possible Termination of Phase B

It is possible that development of Phase B of the Generating Facility will not be completed. In Appendix C, Section 8, the Agreement provides that North Gila has the right to terminate its obligations under the Agreement consistent with the provisions for termination provided in Article 2.3 and 2.4 of the Agreement. These provisions ensure that any financial commitments properly incurred by the transmission owners associated with the design, development or construction of associated interconnection facilities and network upgrades, if any, are the responsibility of the Interconnection Customer.

IV. CONTENTS OF THE FILING

Enclosed for filing are copies of each of the following:

1. This transmittal letter;
2. Attachment A: Detailed Explanation of Variations from *Pro Forma* Articles and Appendices;
3. Attachment B-1: Service Agreement No. 303 under APS's FERC Electric Tariff, Fourteenth Revised Volume No. 2;
4. Attachment B-2: Service Agreement No. 27 under SDG&E's FERC Electric Tariff, Original Volume No. 11;
5. Attachment B-3: Service Agreement No. 1566 under the CAISO FERC Electric Tariff, Fourth Replacement Volume No. II;
6. Attachment C: A redline comparing the Agreement with the APS *pro forma* LGIA in Appendix 6 to Attachment O of the APS Open Access Transmission Tariff;⁴¹
7. Attachment D: A redline comparing the Agreement with the CAISO *pro forma* LGIA in Appendix Z to the CAISO Tariff;⁴²
8. Attachment E: A redline comparing the APS Attachment O LGIA and CAISO Appendix Z LGIA. Attachment E is not required by Commission regulations, but is provided to facilitate understanding of the differences between the APS LGIA and the CAISO LGIA.
9. A certificate of service.

In addition, the Filing Parties have included an electronic version of each document on the enclosed CD-ROM.

⁴¹ For ease of reference the headers and footers were removed from the APS LGIA prior to the creation of the redline comparison; therefore, the deletion of the headers and footers is not reflected in the redline comparison. To the extent necessary, the Filing Parties request waiver of the requirements of sections 35.10(b) and (c), 18 C.F.R. §§ 35.10(b) and 35.10(c) with respect to the headers and footers.

⁴² For ease of reference the headers and footers were removed from the CAISO LGIA prior to the creation of the redline comparison; therefore, the deletion of the headers and footers is not reflected in the redline comparison. To the extent necessary, the Filing Parties request waiver of the requirements of sections 35.10(b) and (c), 18 C.F.R. §§ 35.10(b) and 35.10(c) with respect to the headers and footers.

V. REQUEST FOR WAIVERS

The Filing Parties respectfully request that the Commission grant whatever waivers of any applicable Commission rules and regulations necessary for acceptance of this filing and the Agreement on the date requested under the FPA.

VI. SERVICE

Copies of this filing are being served upon the Arizona Corporation Commission, the California Public Utilities Commission, the Imperial Irrigation District, and the Interconnection Customer. In addition, the filing has been posted on the CAISO's website.

VII. COMMUNICATIONS

The Filing Parties request that all copies of notices and correspondence related to this filing be sent to:

Suzanne K. McBride*
Senior Attorney Regulatory
Pinnacle West Capital Corporation
400 N. Fifth Street
Mail Station 8695
Phoenix, AZ 85004
(602) 250-3626
Suzanne.McBride@pinnaclewest.com

John D. McGrane*
Morgan, Lewis & Bockius LLP
1111 Pennsylvania Ave., NW
Washington, DC 20004
(202) 739-5621
jmcgrane@morganlewis.com

Steven Williams
FERC Case Manager
San Diego Gas & Electric Company
8330 Century Park Court, CP32H
San Diego, CA 92123
(858) 650-6158
swilliams@semprautilities.com

James F. Walsh*
Sempra Energy
101 Ash Street
San Diego, CA 92101-2017
(619) 696-5022
JFWalsh@semprautilities.com

Michael D. Dozier*
Senior Counsel
California Independent System Operator
Corporation
151 Blue Ravine Rd.
Folsom, CA 95630
(916) 608-7048
MDozier@caiso.com

* Individuals designated for service pursuant to Rule 203(b)(3), 18 C.F.R. § 203(b)(3).

VIII. POSITION OF NON-FILING PARTIES AND STATUS OF BOARD APPROVALS

The Filing Parties have been authorized to state that representatives of IID and SDG&E support this filing of the Agreement, contingent upon approval by their respective Boards. IID intends to seek approval to execute the Agreement from its Board at a meeting that is expected to take place on June 22, 2010. Similarly, the Agreement will be presented to the SDG&E Board at a meeting scheduled for June 15, 2010. It is expected that SDG&E's Board will approve the Agreement, and SDG&E will execute it shortly thereafter. The Filing Parties will promptly notify the Commission of the respective Board approvals when they occur.

The Interconnection Customer has executed the Agreement and the Filing Parties have been authorized to state that the Interconnection Customer has reviewed and concurs with this filing.

IX. REQUEST FOR EFFECTIVE DATE

For the reasons set forth above, the Filing Parties respectfully request that the Commission accept the enclosed Agreement for filing, effective sixty-one days after the date it is filed. Acceptance by this date is required in order for the project to be financed and for APS to commence construction by October 1, 2010, as provided for in the Agreement. APS must commence construction by this date in order for the Interconnection Customer to be able to meet its in-service date.

Respectfully submitted,

Arizona Public Service Company

By: 

John D. McGrane
Morgan, Lewis & Bockius LLP
1111 Pennsylvania Avenue, NW
Washington, DC 20004
(202) 739-5621
jmcgrane@morganlewis.com

Counsel for Arizona Public Service Company

San Diego Gas & Electric Company

By: 

James F. Walsh Esq.
Sempra Energy
101 Ash Street
San Diego, CA 92101-2017
(619) 696-5022
JFWalsh@semprautilities.com

Counsel for San Diego Gas & Electric Company

California Independent System Operator Corporation

By: 

Nancy Saracino
General Counsel
Michael D. Dozier
Senior Counsel
California Independent System Operator Corporation
151 Blue Ravine Rd.
Folsom, CA 95630
(916) 608-7048
MDozier@caiso.com

Counsel for the California Independent System Operator Corporation

ATTACHMENT A

Detailed Explanation of Variations in the Agreement from the APS and CAISO LGIA Articles and Appendices

**Attachment A: Detailed Explanation of Variations in the Agreement from the
APS and CAISO LGIA Articles and Appendices**

Overall Approach: In this Attachment A the Filing Parties provide a detailed explanation for variations from the APS and CAISO LGIAs,¹ both of which are implicated due to the dual interconnection requests by the Interconnection Customer, as explained in Section I.C of the Transmittal Letter. The APS LGIA is virtually identical to the *pro forma* LGIA adopted by the Commission in Order No. 2003. The CAISO LGIA incorporates significant differences from the Order No. 2003 LGIA, particularly including differences to accommodate more than two parties to the LGIA, which differences have been accepted by the Commission. To the extent that it was necessary in the Agreement to reconcile differences between the APS LGIA and CAISO LGIA² provisions, the differences between the APS LGIA and the CAISO LGIA are explained in this Attachment A.

This Attachment A has two sections. The first section provides a master list of reasons for variations since many of the articles were modified for recurring reasons and also explains cross-references used to refer the reader to the detailed discussion of some provisions in the Transmittal Letter. In the second section, this master list of reasons is applied to every definition, Article, and Appendix in the Agreement in the order in which they appear in the Agreement.

I. MASTER LIST OF REASONS FOR VARIATION

Many of the reasons for lack of conformity with the APS and CAISO LGIAs³ are the same for multiple provisions. In order to help the Commission analyze the many non-conforming changes in the Agreement, and to avoid excessive repetition, a master list of reasons for variation and list of standard cross references is being provided in this section and will be applied in the next section to explain the reasons for the variations or refer the reader to a more detailed discussion in the Transmittal Letter. When the detailed explanation includes a cross-reference to a topic covered in the Transmittal Letter, it is made as follows:

See Transmittal Letter at Section __.

¹ As explained in the Transmittal Letter, the APS Standard Large Generator Interconnection Agreement has been accepted by the Commission as APS FERC Electric Tariff, Fourteenth Revised Volume No. 2, Appendix 6 to Attachment O (“APS LGIA”). *See Arizona Pub. Serv. Co.*, Docket No. ER07-1142 (letter order November 26, 2007).

² As explained in the Transmittal Letter, the CAISO’s Large Generator Interconnection Agreement for Interconnection Requests in a Queue Cluster Window has been accepted by the Commission as CAISO tariff Appendix Z (“CAISO LGIA”). *See California Indep. Sys Operator Corp.*, Docket No. ER08-1317, 124 FERC ¶ 61,292 (2008) (initial order approving tariff reforms instituted as part of CAISO’s generator interconnection process reform); *order on reh’g*, 127 FERC ¶ 61,177 (2008); and 128 FERC ¶ 61,247 (2009) (order on compliance filing). The CAISO tariff also includes as Appendix V a Standard Large Generator Interconnection Agreement that is not applicable to interconnection requests in a queue cluster window. As the interconnection request submitted to the CAISO related to the Agreement was incorporated into a queue cluster window pursuant to the CAISO tariff, the CAISO LGIA in Appendix Z of the CAISO tariff is the appropriate version to which to compare this Agreement.

³ As noted above, the APS LGIA is virtually identical to the *pro forma* LGIA adopted by the Commission in Order No. 2003. In most instances, where the APS LGIA is different from the Order No. 2003 *pro forma* LGIA, those variations are indicated in this Attachment A.

When the short-hand term in [brackets] in the master list below is found in the detailed explanation of variations from the APS and CAISO LGIAs, the explanation provided in this master list is intended. In the detailed explanation in Section II, some of the simplified explanations provided in this master list are supplemented with additional detail to explain why the variation was necessary.

1. **[Differences between APS LGIA and CAISO LGIA]:** The provision was modified because there are significant differences between the APS and CAISO LGIAs that relate to this provision. Note that when this reason is provided, the nature of the difference and the way the difference was reconciled is further explained. In most instances, the provision was modified to conform to the CAISO LGIA provision, which previously has been approved by the Commission. The filing includes as Attachment E a redline comparison of the APS LGIA and the CAISO LGIA to assist the Commission with understanding the difference between the APS and CAISO LGIAs.
2. **[More than two Parties]:** The APS LGIA is drafted to apply to two parties, while the CAISO LGIA is drafted to apply to more than two parties. This Agreement has six Parties. Consequently, the Agreement incorporates provisions for multiple parties, in many cases conforming to or adapted from the CAISO LGIA provisions for more than two parties.
3. **[Need to make specific references]:** The provision was modified since the use of the generic APS or CAISO LGIA language would have made this Agreement ambiguous. The need for specific references is explained in the Transmittal Letter at Section II.C. There are several ways this Agreement has been made more specific. Generally, one or more recurring reasons for making provisions more specific are stated in (parentheses) to identify the way in which the Agreement was made more specific. In particular:
 - **(Transmission Provider):** As in the CAISO LGIA, the generic term “Transmission Provider” was too vague to use in this Agreement since there are multiple Parties with different roles to play with respect to providing transmission under this Agreement. The term was replaced as appropriate with a reference to the “Transmission Owners” or to the names of the Parties that would serve the specified role. Where the “Transmission Provider” role was changed in the CAISO LGIA to include only the transmission owner, the same change was made in this Agreement. Where the CAISO is assigned responsibility in the CAISO LGIA, a determination was made whether the CAISO should have similar responsibilities in this Agreement or whether APS would be the appropriate entity to assume the responsibilities as the operating agent for the transmission owners. This change also was necessary because, as defined by FERC in the Order No. 2003 *pro forma* LGIA as well as in APS’ LGIA, the term “Transmission Provider” means the “public utility that . . . provides transmission service under the Tariff.” Here, IID – one of the co-owners of the JPP – is not a “public utility” subject to FERC’s jurisdiction under Sections 205 or 206 of the Federal Power Act and there are multiple tariffs under which Parties to the Agreement provide transmission service.

- **(Operating Agent of the JPP):** The generic term “Transmission Owner,” while used in this Agreement, was replaced when necessary to clarify when APS is to act on behalf of the transmission owners, in its capacity as operating agent of the Joint Participation Project.
 - **(Parties):** The term “Parties,” while used in this Agreement, was sometimes replaced with more specific references when the intent was to refer to only some of the Parties to the Agreement.
 - **(Transmission System):** The term “Transmission System,” while used in this Agreement, was sometimes replaced with a more specific reference to the jointly owned transmission line, defined as the “Joint Participation Project” or JPP. The CAISO LGIA also uses terms other than “Transmission System” to refer to elements of the transmission system described in the CAISO LGIA. However, many of the references in the Agreement are variances from both the APS LGIA and the CAISO LGIA that are necessary to address the special circumstances of the multi-Party ownership of some affected facilities and potentially individual Party ownership of others.
 - **(Project Phase):**
 - The term “Generating Facility,” while used in this Agreement, was sometimes replaced with more specific references to each of the project phases, as needed, to clarify the intent of the Agreement. In many instances, this is a variance from both the APS LGIA and the CAISO LGIA that is necessary to address the special circumstances of the particularly separate treatment of the two phases of the Generating Facility in the Agreement.
 - The terms “Appendix A” (Interconnection Facilities, Network Upgrades, and Distribution Upgrades) and “Appendix B” (Milestones) were modified to refer instead to multiple appendices, Appendices A-1, A-2, and A-3 and Appendices B-1, B-2, and B-3. These appendices were divided to make it possible to refer easily to the specific appendices which apply to Phase A of the Interconnection Project (A-1 and B-1), Phase B of the Interconnection Project (A-2 and B-2), and the possible non-JPP SDG&E network upgrades associated with Phase B of the Interconnection Project (A-3 and B-3).
4. **[Conforming to APS and CAISO LGIAs]:** The provision is the same as in the APS LGIA and the CAISO LGIA.
 5. **[No substantive change to APS or CAISO LGIA]:** The provision was *not* modified in a way that amounts to a substantive change to the APS or CAISO LGIA provision. This reason is provided only when the meaning of the provision is the same as that in the APS and CAISO LGIAs. In many instances, the corresponding provisions of the APS LGIA and CAISO LGIA are the same. For instance, there are several places in the Agreement where the only change made was to replace the term “LGIA” with the term “Agreement.”
 6. **[Participation of IID]:** The provision was modified because IID is a party to the Agreement and IID is a governmental entity and not a public utility subject to the Commission’s jurisdiction under Sections 205 and 206 of the Federal Power Act.

7. **[Phasing of project]:** The provision was modified because the Generating Facility will be constructed in two project phases. This term is used when the modifications made were more substantial than merely referring to the project phases separately. As explained above, modifications limited to referring to project phases separately are indicated by using the words “[Need to make specific references (Project Phase)].”
8. **[This provision is not applicable to this Agreement]:** The provision was eliminated from the Agreement because it is not applicable to the particular circumstances of the Interconnection Customer and therefore is not needed for the Agreement.

II. DETAILED EXPLANATION

Recitals

The recitals in this Agreement have been modified to provide background regarding the unique circumstances which led to the Agreement.

ARTICLE 1. DEFINITIONS

- **Adverse System Impact**

[Conforming to APS and CAISO LGIAs]

- **Affected System, Affected System Operator, Affected System Construction and Operation Agreement, Affected System Study, Affected System Study Agreement**

These provisions were modified to be specific to the circumstances of this particular interconnection, particularly including the special circumstances of IID as both an Affected System and a party to this Agreement in relation to this interconnection. *See* Transmittal Letter at Section II.B.

- **Affiliate**

[Conforming to APS and CAISO LGIAs]

- **Ancillary Services**

[Need to make specific references (Transmission Provider)]

[Differences between APS LGIA and CAISO LGIA] The provision is based on the APS LGIA.

- **Applicable Laws and Regulations**

[Conforming to APS and CAISO LGIAs]

- **Applicable Reliability Council**

[Differences between APS LGIA and CAISO LGIA] The provision refers specifically to WECC, to conform to the CAISO LGIA.

- **Applicable Reliability Standards**

[Differences between APS LGIA and CAISO LGIA] The provision refers to the “Balancing Authority” rather than the “Control Area,” to bring the definition into closer conformity with the CAISO LGIA. However, a portion of the provisions of the CAISO LGIA were omitted to accommodate the special circumstances of the Interconnection Customer, which has requested that the Balancing Authority Area for Phase B be left for future determination.

- **Balancing Authority, Balancing Authority Area (and deletion of “Control Area”)**

[Differences between APS LGIA and CAISO LGIA] These provisions refer to “Balancing Authority” and “Balancing Authority Area,” rather than the “Control Area,” to conform to the CAISO LGIA.

- **Base Case**

[Need to make specific references (Transmission Provider)]

- **Breach**

[No substantive change to APS or CAISO LGIA] This provision was modified to use the term “Agreement” rather than “Standard Large Generator Interconnection Agreement” or “LGIA,” because the Agreement does not use the term “Standard Large Generator Interconnection Agreement” or “LGIA” to refer to the Agreement.

- **Breaching Party**

[No substantive change to APS or CAISO LGIA] This provision was modified to use the term “Agreement” rather than “Standard Large Generator Interconnection Agreement” or “LGIA,” because the Agreement does not use the term “Standard Large Generator Interconnection Agreement” or “LGIA” to refer to the Agreement.

- **Business Day**

[Differences between APS LGIA and CAISO LGIA] The definition specifies that the day after Thanksgiving is not a “Business Day,” to conform to the definition in the CAISO LGIA.

- **Calendar Day**

[Conforming to APS and CAISO LGIAs]

- **CAISO Interconnection Service**

[Differences between APS LGIA and CAISO LGIA] *See* Transmittal Letter at Section III.A.

- **Clustering**

[Differences between APS LGIA and CAISO LGIA] The provision conforms to the APS LGIA.

- **Commercial Operation, Commercial Operation Date**

[Need to make specific references (Project Phase)] *See* Transmittal Letter at Section III.D.

- **Confidential Information**

[Differences between APS LGIA and CAISO LGIA] The cross-reference to Article 22.1.2 (which describes the scope of Article 22's Confidentiality provisions) was incorporated at the end of the definition to conform to the CAISO LGIA.

- **Default**

[No substantive change to APS or CAISO LGIA]

- **Dispute Resolution**

[Differences between APS LGIA and CAISO LGIA] The provision conforms to the APS LGIA.

- **Distribution System**

[Need to make specific references (Transmission Provider)]

[Differences between APS LGIA and CAISO LGIA] The provision is based more on the APS LGIA.

- **Distribution Upgrades**

[Need to make specific references (Transmission Provider)]

[Differences between APS LGIA and CAISO LGIA] The provision is based more on the APS LGIA.

- **Effective Date**

[Participation of IID]

[Differences between APS LGIA and CAISO LGIA] The provision omits certain provisions of the CAISO LGIA in favor of the APS LGIA.

- **Emergency Condition**

[Need to make specific references (Transmission Provider)]

- **Energy Resource Integration Service**

[Need to make specific references (Transmission Provider)] and [Differences between APS LGIA and CAISO LGIA] *See* Transmittal Letter at Section III.A.

- **Engineering & Procurement Agreement**

[Differences between APS LGIA and CAISO LGIA] This definition is based on the APS LGIA and was modified to refer specifically to the Engineering & Procurement Agreement for the Generating Facility that is the subject of this Agreement.

- **Environmental Law**

[Conforming to APS and CAISO LGIAs]

- **Federal Power Act**

[Conforming to APS and CAISO LGIAs]

- **FERC**

[No substantive change to APS or CAISO LGIA]

- **Force Majeure**

The term “earthquake” was added at the request of IID because the term has been added to the IID tariff.

- **Generating Facility**

[Phasing of project]

- **Generating Facility Capacity**

[Conforming to APS and CAISO LGIAs]

- **Good Utility Practice**

[No substantive change to APS or CAISO LGIA] This definition conforms to the substance of the definition found in both the APS LGIA and the CAISO LGIA, using the plural terms in the phrase “optimum practices, methods, or acts” from the CAISO LGIA.

- **Governmental Authority**

[Need to make specific references (Transmission Provider)]

- **Hazardous Substances**

[Conforming to APS and CAISO LGIAs]

- **Initial Synchronization Date**

[Need to make specific references (Project Phase)] *See* Transmittal Letter at Section III.D.

- **In-Service Date**

[Need to make specific references (Transmission Provider)]

- **Interconnection Customer**

[Differences between APS LGIA and CAISO LGIA] The provision is based on the APS LGIA.

[Need to make specific references (Project Phase)] *See* Transmittal Letter at “Interconnection Customer.”

- **Interconnection Customer’s Interconnection Facilities**

[Need to make specific references (Transmission System) (Project Phase)]

[Phasing of project]

- **Interconnection Facilities**

[Need to make specific references (Transmission Provider) (Transmission System)]

- **Interconnection Facilities Study**

[Differences between APS LGIA and CAISO LGIA] and [Need for specific references (Transmission Provider)] The provision is based on the APS LGIA and was modified to refer specifically to APS since the CAISO no longer prepares a study by this name.

- **Interconnection Feasibility Study**

[Differences between APS LGIA and CAISO LGIA] [Need for specific references (Transmission Provider)] The provision is based on the APS LGIA and was modified to refer specifically to APS since the CAISO no longer prepares a study by this name.

- **Interconnection Financial Security**

[Differences between APS LGIA and CAISO LGIA] This term was incorporated in the Agreement to conform to the CAISO LGIA and includes a non-substantive change to the CAISO definition. *See* Transmittal Letter at Section III.E.1.

- **Interconnection Request**

[Differences between APS LGIA and CAISO LGIA] The provision is based more on the APS LGIA.

[Need for specific references (Transmission Provider)] The provision was modified because the Interconnection Customer made interconnection requests to both APS and the CAISO.

[Phasing of project]

- **Interconnection Service**

[Need to make specific references (Transmission Provider) (Transmission System) (Project Phase)]

- **Interconnection Study**

The provision was modified because the Interconnection Customer made interconnection requests to both APS and the CAISO, so interconnection studies were prepared by both.

- **Interconnection System Impact Study**

[Need to make specific references (Transmission Provider) (Transmission System)]

[Differences between APS LGIA and CAISO LGIA] The provision is based on the APS LGIA and was modified to make it clear that only APS prepared an Interconnection System Impact Study since the CAISO no longer prepares a study by this name.

- **Interconnection System Impact Study Agreement**

[Differences between APS LGIA and CAISO LGIA] The provision is based on the APS LGIA and was modified to make it clear that only APS entered into an Interconnection System Impact Study Agreement since the CAISO no longer prepares such a study.

- **IRS**

[Conforming to APS and CAISO LGIAs]

- **Joint Operating Committee**

[Need to make specific references (Transmission Provider) (Operating Agent of the JPP)]

[Differences between APS LGIA and CAISO LGIA] This provision is based on the APS LGIA.

- **Joint Participation Project**

This definition was added to be able to refer specifically to the transmission line that is jointly owned under the Participation Agreement.

- **Large Generating Facility**

[Conforming to APS and CAISO LGIAs]

- **Large Generator Interconnection Procedures**

[Differences between APS LGIA and CAISO LGIA] The provision is based on the CAISO LGIA with modifications to recognize that the Interconnection Customer made interconnection requests to both APS and the CAISO, so both LGIPs are relevant.

- **Loss**

[Differences between APS LGIA and CAISO LGIA] The provision does not include the phrase “arising out of or resulting from the other Party’s performance, or non-performance of its obligations under the Standard Large Generator Interconnection Agreement on behalf of the indemnifying Party, except in cases of gross negligence or intentional wrongdoing by the indemnifying Party” to conform to the CAISO LGIA.

- **Material Modification**

[Differences between APS LGIA and CAISO LGIA] The provision includes the phrase “or any other valid interconnection request” to conform to the CAISO LGIA.

- **Metering Equipment**

[Differences between APS LGIA and CAISO LGIA] The provision specifically refers to metering equipment installed or to be installed “for measuring the output” at the Generating Facility, to conform substantively to the CAISO LGIA.

- **NERC**

The provision was modified to update it since the organization is no longer known as a “Council,” it is known as a “Corporation.”

- **Network Resource, Network Resource Interconnection Service**

[Differences between APS LGIA and CAISO LGIA] *See* Transmittal Letter at Section III.A.

- **Network Upgrades**

[Need to make specific references (Transmission Provider) (Transmission System)]

- **Notice of Dispute**

[Differences between APS LGIA and CAISO LGIA] This provision is based on the APS LGIA with non-substantive changes.

- **Operating Agent of the JPP**

This definition was added to identify APS as the entity designated as the operating agent of the JPP pursuant to the Participation Agreement.

- **Ownership Interests**

[Need to make specific references] This definition was added since there are several places in the Agreement where it is necessary to refer to the ownership shares of the transmission owners under the Participation Agreement.

- **Party or Parties**

[Need to make specific references (Transmission Provider)]

- **Phase I Interconnection Study, Phase II Interconnection Study**

[Differences between APS LGIA and CAISO LGIA] These terms were incorporated based on the CAISO LGIA. The definitions refer to the CAISO tariff rather than incorporating the substantively same definitions from the CAISO LGIA for simplicity. As explained in the transmittal letter, the CAISO has made significant changes to its interconnection study process including moving to the study of cluster groups to a two phase study process.

- **Phase A of the Generating Facility, Phase B of the Generating Facility, Phase A of the Interconnection Project, Phase B of the Interconnection Project**

[Phasing of project] These terms were added to the Agreement to reflect the fact that this Generating Facility is contemplated to be completed in two phases.

- **Point of Change of Ownership**

[Need to make specific references (Transmission Provider) (Project Phase)]

- **Point of Interconnection**

[Need to make specific references (Transmission System) (Project Phase)]

- **Project Block**

This term was added to reflect the nature of the Generating Facility, which uses photovoltaic technologies that are different from traditional generating facilities, and will be brought on-line in different blocks. *See* Transmittal Letter at Section III.D.

- **Project Phase**

[Phasing of project] This term was added to the Agreement to reflect the fact that this Generating Facility is contemplated to be completed in two phases.

- **Queue Position**

[Differences between APS LGIA and CAISO LGIA] and [Need to make specific references (Transmission Provider)] The provision is based on the APS LGIA and was modified because the Interconnection Customer made interconnection requests to both APS and the CAISO, so it was in two queues.

- **Reasonable Efforts**

[No substantive change to APS or CAISO LGIA]

- **Scoping Meeting**

[Need to make specific references (Transmission Provider)]

- **Site Control**

[Differences between APS LGIA and CAISO LGIA] The provision conforms to the APS LGIA.

- **Small Generating Facility**

[Differences between APS LGIA and CAISO LGIA] The provision conforms to the APS LGIA.

- **Stand Alone Network Upgrades**

[Need to make specific references (Transmission Provider) (Project Phase)]

- **System Protection Facilities**

[Need to make specific references (Transmission Provider) (Transmission System)]

[Differences between APS LGIA and CAISO LGIA] The provision incorporates the words “required to protect” rather than “that protects” to conform to the CAISO LGIA.

- **Tariff**

[Need to make specific references (Transmission Provider)]

[Differences between APS LGIA and CAISO LGIA] The provision is based on the APS LGIA.

[Participation of IID]

- **Transmission Owner(s)**

[Differences between APS LGIA and CAISO LGIA] The provision is based on the APS LGIA.

[Need to make specific references (Transmission Provider) (Operating Agent of the JPP)] The provision was modified since it was necessary to make clear who the joint transmission owners are and that APS is the operating agent that acts on behalf of them under the Participation Agreement.

- **Transmission Owners' Interconnection Facilities**

[Differences between APS LGIA and CAISO LGIA] The provision is based on the APS LGIA.

[Need to make specific references (Transmission Provider) (Project Phase)]

- **Transmission System**

[Differences between APS LGIA and CAISO LGIA] The provision is based on the APS LGIA.

[Need to make specific references] This provision was modified to make it more specific in light of the joint ownership of the line. The definition makes it clear that the term includes the transmission system of each of the joint owners of the line and the transmission system controlled by the CAISO, but notes that each transmission owner provides service under a different tariff.

- **Trial Operation**

[Phasing of project]

Terms in the APS LGIA Omitted from the Agreement

- **Transmission Provider**

This definition was omitted from the Agreement because of the need to be specific as to the roles of the many Parties to the Agreement. Also, it was omitted because, as defined by FERC in the Order No. 2003 *pro forma* LGIA as well as in APS' LGIA, the term "Transmission Provider" means the "public utility that . . . provides transmission service under the Tariff." Here, IID is not a "public utility" subject to FERC's jurisdiction under Sections 205 or 206 of the Federal Power Act and there are multiple tariffs under which Parties to the Agreement provide transmission service. Rather than using this generic term, the Parties specifically identified to whom a provision applied.

- **Standard Large Generator Interconnection Agreement**

Due to the unique nature of this Agreement, this term was replaced with the term "Agreement."

- **Standard Large Generator Interconnection Procedures**

This term was replaced with the term "Large Generator Interconnection Procedures (LGIP)."

- **Interconnection Facilities Study Agreement, Interconnection Feasibility Study Agreement, Optional Interconnection Study, Optional Interconnection Study Agreement,**

[Differences between APS LGIA and CAISO LGIA] All of the terms above are only found in the APS LGIA, not in the CAISO LGIA, because there are differences between the APS and CAISO LGIPs. Rather than reconciling this difference, these terms were omitted from the Agreement because they are not needed for this Agreement.

Terms in the CAISO LGIA Omitted from the Agreement

- **CAISO Controlled Grid, CAISO Tariff, Electric Generating Unit, Interconnection Handbook, Large Generator Interconnection Study Process Agreement, Operational Control, Participating TO's Delivery Network Upgrades, Participating TO's Interconnection Facilities, Participating TO's Reliability Network Upgrades, Participating TO's Transmission System, QF PGA, Qualifying Facility, Transmission Control Agreement**

[Differences between APS LGIA and CAISO LGIA] All of the terms above are only found in the CAISO LGIA, not in the APS LGIA. In reconciling the APS and CAISO LGIAs, the provisions of the CAISO LGIA in which these terms are used were omitted from this Agreement. As a result, these terms were omitted from the Agreement because they are not needed for this Agreement.

ARTICLE 2. EFFECTIVE DATE, TERM, AND TERMINATION

2.1 Effective Date

[Participation of IID] This provision was clarified to reflect the participation of IID, which is not a public utility subject to FERC's jurisdiction under Sections 205 or 206 of the Federal Power Act.

2.2 Term of Agreement

[No substantive change to APS or CAISO LGIA]

2.3 Termination Procedures

2.3.1 Written Notice

[Need to make specific references (Transmission Provider) (Operating Agent of the JPP)]

[Phasing of project]

See Transmittal Letter at Section III.F.2

2.3.2 Default

[More than two Parties]

2.3.3 and omission of CAISO LGIA 2.3.3

[Differences between APS LGIA and CAISO LGIA] The provision is based more on the APS LGIA. The provisions of CAISO LGIA Article 2.3.3 were omitted as redundant, and the provisions of CAISO Article 2.3.4 referring to termination cost obligations were omitted from Article 2.3.3 of the Agreement as potentially creating an ambiguity in relation to Article 2.6.

[Participation of IID] This provision also was clarified to reflect the fact that IID is not a public utility subject to FERC's jurisdiction under Sections 205 or 206 of the Federal Power Act

2.4 Termination Costs

[Need to make specific references (Transmission Provider) (Operating Agent of the JPP) (Parties) (Project Phases)]

[Differences between APS LGIA and CAISO LGIA] A substantial portion of the provisions regarding the Interconnection Customer's responsibilities are based on the CAISO LGIA with a number of non-substantive differences. *See* Transmittal Letter at Section III.E.1.

2.4.1

[Need to make specific references (Transmission Provider)]

[Differences between APS LGIA and CAISO LGIA]:

- This provision incorporates the term “Interconnection Facilities” from the CAISO LGIA in lieu of the term “facilities.”
- This provision also omits the last paragraph of this provision from the APS LGIA since this subject addressed there is covered in Article 2.4 of the Agreement, conforming to the CAISO LGIA.

2.4.2

[Need to make specific references (Transmission Provider)]

2.4.3

[No substantive change to APS or CAISO LGIA]

2.5 Disconnection

[Need to make specific references (Operating Agent of the JPP) (Parties) (Transmission System) (Project Phases)]

[Phasing of project]

See Transmittal Letter at Section III.F.2.

2.6 Survival

[More than two Parties]

ARTICLE 3. REGULATORY FILINGS

3.1 Filing

[Need to make specific references (Transmission Provider)]

[Participation of IID]

Omission of CAISO LGIA Articles 3.2, 3.3, and 3.4

[Differences between APS LGIA and CAISO LGIA] *See* Transmittal Letter at Section II.D.

ARTICLE 4. SCOPE OF SERVICE

4.1 Interconnection Product Options

[Differences between APS LGIA and CAISO LGIA] *See* Transmittal Letter at Section III.A.

4.1.1 CAISO Interconnection Service

[Differences between APS LGIA and CAISO LGIA] *See* Transmittal Letter at Section III.A.

4.1.2 Energy Resource Interconnection Service

[Differences between APS LGIA and CAISO LGIA] *See* Transmittal Letter at Section III.A.

4.1.2.1 The Product

[Differences between APS LGIA and CAISO LGIA] *See* Transmittal Letter at Section III.A.

[Participation of IID]

The description of the Energy Resource Interconnection Service contained in the APS LGIA was modified to include IID in its role as a co-owner of the JPP.

4.1.2.2 Transmission Delivery Service Implications

[Differences between APS LGIA and CAISO LGIA] *See* Transmittal Letter at Section III.A.

[Participation of IID]

4.1.3 Network Resource Interconnection Service

4.1.3.1 The Product

[This provision is not applicable to this Agreement and has been removed]

4.1.3.2 Transmission Delivery Service Implications

[This provision is not applicable to this Agreement and has been removed]

4.2 Provision of Service

[Need to make specific references (Transmission Provider) (Operating Agent of the JPP)]

See Transmittal Letter at Section III.A.

4.3 Performance Standards

[Need to make specific references (Transmission Provider)]

[More than two Parties]

[Participation of IID]

4.4 No Transmission Delivery Service

[Need to make specific references (Transmission Provider)]

[Differences between APS LGIA and CAISO LGIA] The APS LGIA’s use of the term “transmission delivery service” was chosen over the CAISO LGIA’s use of the term “transmission service.” Since the term “Point of Delivery” is not defined, the initial caps were eliminated to make the provision conform to the CAISO LGIA.

4.5 Interconnection Customer Provided Services

[No substantive change to APS or CAISO LGIA]

ARTICLE 5. INTERCONNECTION FACILITIES ENGINEERING, PROCUREMENT, AND CONSTRUCTION

[Differences between APS LGIA and CAISO LGIA] The CAISO LGIA introductory provisions were omitted in favor of the approach of the APS LGIA, as APS will be the constructing utility.

5.1 Options

[Need to make specific references (Transmission Provider) (Project Phase)]

5.1.1 Standard Option

[Need to make specific references (Transmission Provider) (Operating Agent of the JPP) (Project Phase)]

5.1.2 Alternate Option

[This provision is not applicable to this Agreement and has been removed]

5.1.3 Option to Build

[This provision is not applicable to this Agreement and has been removed]

5.1.4 Negotiated Option

[This provision is not applicable to this Agreement and has been removed]

5.2 General Conditions Applicable to Option to Build

[This provision is not applicable to this Agreement and has been removed]

5.3 Liquidated Damages

[This provision is not applicable to this Agreement and has been removed] Provisions regarding liquidated damages are only relevant to Articles 5.1.2 and 5.1.4, and both of those articles have been omitted from the Agreement as inapplicable to the circumstances of the Interconnection Customer.

5.4 Power System Stabilizers

See Transmittal Letter at Section III.D.2.

5.5 Equipment Procurement

The APS and CAISO LGIA language was modified because of the existence of the Engineering and Procurement Agreement.

Note that **Articles 5.5.1, 5.5.2, and 5.5.3**, which concern when procurement is to begin, were removed from the Agreement since this subject matter is covered in the Engineering and Procurement Agreement.

5.6 Construction Commencement (and subsections)

[Need to make specific references (Transmission Provider) (Operating Agent of the JPP) (Project Phase)]

[Phasing of project]

See Transmittal Letter at Section II.B and Section III.G.

5.7 Work Progress

[More than two Parties]

[Need to make specific references (Transmission Provider)]

5.8 Information Exchange

[Need to make specific references (Transmission Provider) (Parties)]

5.9 Limited Operation

[Need to make specific references (Transmission Provider) (Project Phase)]

5.10 Interconnection Customer’s Interconnection Facilities (‘ICIF’)

[Need to make specific references (Project Phase)]

5.10.1 Interconnection Customer’s Interconnection Facility Specifications

[Differences between APS LGIA and CAISO LGIA] The provision is based more on the APS LGIA.

[Need to make specific references (Transmission Provider) (Operating Agent of the JPP) (Project Phase)]

5.10.2 Review by Transmission Owners and CAISO

[Need to make specific references (Transmission Provider)]

5.10.3 ICIF Construction

[Need to make specific references (Transmission Provider) (Operating Agent of the JPP) (Project Phase)]

[Differences between APS LGIA and CAISO LGIA] The APS LGIA provision was supplemented by adding language at the end concerning deviations from what was originally submitted by the Interconnection Customer. This language was added to make the provision conform more closely to the CAISO LGIA.

Omission of CAISO LGIA Article 5.10.4

[Differences between APS LGIA and CAISO LGIA] The provisions of CAISO LGIA Article 5.10.4 were omitted because APS will be the constructing utility, and APS has its own interconnection requirements.

5.11 Transmission Owners’ Interconnection Facilities Construction

[Need to make specific references (Transmission Provider) (Operating Agent of the JPP)]

5.12 Access Rights

[Need to make specific references (Transmission System)]

5.13 Lands of Other Property Owners

[Need to make specific references (Transmission Provider)]

5.14 Permits

[Need to make specific references (Transmission Provider)]

5.15 Early Construction of Base Case Facilities

[Need to make specific references (Transmission Provider) (Transmission System)]

This provision was also modified to reflect changes to defined terms made in this Agreement

[Differences between APS LGIA and CAISO LGIA] The APS LGIA provision was slightly modified by replacing the term “Interconnection Customer” with “interconnection customer” in one instance in the last sentence since in this case a reference to the defined term used in the Agreement was not intended, conforming to the CAISO LGIA.

5.16 Suspension

[Need to make specific references (Transmission Provider) (Operating Agent of the JPP) (Project Phase)]

[Differences between APS LGIA and CAISO LGIA] While the APS LGIA Article was modified primarily to make it more specific, it contains an addition in the first paragraph which limits the ability of the Interconnection Customer to suspend construction of network upgrades being built for multiple generators. This addition is explained in the Transmittal Letter. *See* Transmittal Letter at Section III.E.2. Also in the first paragraph, the term “Applicable Reliability Standards” has been added to conform to the CAISO LGIA.”

5.17 Taxes

5.17.1 Interconnection Customer Payments Not Taxable

[Need to make specific references (Transmission Provider)] The provision was modified to change “Transmission Provider” or “Participating TO” to “Transmission Owner.” This is not a substantive change to the APS or CAISO LGIA since only transmission owners face potential tax liability, not the CAISO.

[Differences between APS LGIA and CAISO LGIA] The word “refundable” was added to the provisions of the APS LGIA to reference to the treatment of potential payments or property transfers by the Interconnection Customer to the transmission owners as advances (*i.e.*, “refundable advances”), to conform to the CAISO LGIA. The referenced provision was incorporated into the CAISO LGIA Article 5.17.1 to reflect private letter rulings that spoke in terms of refundable advances obtained by certain interconnecting customers requesting interconnections to SDG&E's transmission system.

5.17.2 Representations and Covenants

[Need to make specific references (Transmission Provider)] The provision was modified to change “Transmission Provider” or “Participating TO” to “Transmission Owner.” This is not a substantive change to the APS or CAISO LGIA since only transmission owners face potential tax liability, not the CAISO. The provision also includes another non-substantive difference from the CAISO LGIA in omitting the phrase “without possibility of refund or credit.”

5.17.3 Indemnification for the Cost Consequences of Current Tax Liability Imposed Upon the Transmission Owner

[Need to make specific references (Transmission Provider)] The provision was modified to change “Transmission Provider” or “Participating TO” to “Transmission Owner.” This is not a substantive change to the APS or CAISO LGIA since only transmission owners face potential tax liability, not the CAISO. The provision also includes another non-substantive difference from the CAISO LGIA in omitting an explanatory parenthetical phrase.

5.17.4 Tax Gross-Up Amount

[Need to make specific references (Transmission Provider)] The provision was modified to change “Transmission Provider” or “Participating TO” to “Transmission Owner.” This is not a substantive change to the APS or CAISO LGIA since only transmission owners face potential tax liability, not the CAISO. The provision was also modified to refer to specific project phases.

5.17.5 Private Letter Ruling or Change or Clarification of Law

[Need to make specific references (Transmission Provider)] The provision was modified to change “Transmission Provider” or “Participating TO” to “Transmission Owner.” This is not a substantive change to the APS or CAISO LGIA since only transmission owners face potential tax liability, not the CAISO. The provision also includes another non-substantive difference from the CAISO LGIA in omitting a clarifying clause that isn’t essential to the provision.

5.17.6 Subsequent Taxable Events

[Need to make specific references (Transmission Provider)] The provision was modified to change “Transmission Provider” or “Participating TO” to “Transmission Owner.” This is not a substantive change to the APS or CAISO LGIA since only transmission owners face potential tax liability, not the CAISO.

5.17.7 Contests

[Need to make specific references (Transmission Provider)] The provision was modified to change “Transmission Provider” or “Participating TO” to “Transmission Owner.” This is not a substantive change to the APS or CAISO LGIA since only transmission owners face potential tax liability, not the CAISO. The provision also includes other non-substantive differences from the CAISO LGIA in omitting clarifying provisions that are not essential to the provision.

5.17.8 Refund

[Need to make specific references (Transmission Provider)] The provision was modified to change “Transmission Provider” or “Participating TO” to “Transmission Owner.” This is not a substantive change to the APS or CAISO LGIA since only transmission owners face potential tax liability, not the CAISO.

5.17.9 Taxes Other Than Income Taxes

[Need to make specific references (Transmission Provider)]

Note that the redline comparison of the Agreement with the APS LGIA suggests that an article [Article 5.17.10] entitled “Transmission Owners Who Are Not Transmission Providers” was omitted. But, this provision of the APS LGIA was removed from FERC’s *pro forma* LGIA in Order 2003-A, 106 FERC ¶ 61,220 at ¶ 384.

5.18 Tax Status

[More than two Parties]

[Need to make specific references (Transmission Providers)]

5.19 Modification

5.19.1 General

[More than two Parties]

[Need to make specific references (Transmission Provider) (Parties) (Project Phases)]

[Participation of IID]

This provision was modified since the APS LGIA assumed a two-party agreement in which there would be only one “Transmission Provider” (and only two “Parties”), but in this Agreement the three transmission owners and the CAISO would all have an interest in determining whether modifications are made. Thus, four types of changes were made: (1) references were made more specific; (2) language was added to make it clear that both the transmission owners and the CAISO shall determine whether there is a material modification; (3) language was added to make it clear that modifications could result in an amendment to the Agreement or a new LGIA; and (4) language was added to clarify that if IID determines a modification requires additional non-JPP facilities owned by IID, such change may be dealt with in a separate Affected System Study Agreement and Affected System Agreement.

This provision was crafted to help make the Agreement comprehensive. *See* Transmittal Letter at Section II.B.

5.19.2 Standards

[More than two Parties]

This provision was modified since it used the term “Party’s facilities” which was highly ambiguous for purposes of this multi-party Agreement. The new language is not intended to substantively modify the provision - only to clarify it for purposes of this Agreement.

5.19.3 Modification Costs

[Need to make specific references (Transmission Provider)]

In the last sentence of the provision, rather than use the term “Interconnection Customer’s Interconnection Facilities” from the APS LGIA, the term “Interconnection Facilities” was used, conforming to the CAISO LGIA. The Interconnection Customer is required to pay the costs for modifying not only Interconnection Customer interconnection facilities, but also the cost of modifications to transmission owners’ interconnection facilities, and the term “Interconnection Facilities” covers both.

ARTICLE 6. TESTING AND INSPECTION

6.1 Pre-Commercial Operation Date Testing and Modifications

[Need to make specific references (Transmission Provider) (Operating Agent of the JPP) (Project Phase)]

The provision is based more on the CAISO LGIA provisions which recognize that some generating technologies, including the Interconnection Customer's solar photovoltaic technology, are built gradually through addition of Project Blocks of between one and two MW at a time. *See* Transmittal Letter at Section III.D.

The provision was also modified because the Parties desired a comprehensive agreement which includes provisions for IID's non-JPP facilities where affected by the proposed interconnection. *See* Transmittal Letter at Section II.B.

6.2 Post-Commercial Operation Date Testing and Modifications

[Need to make specific references (Transmission System) (Project Phase)]

The provision was modified because the Parties desired a comprehensive agreement which includes provisions for IID's non-JPP facilities where affected by the proposed interconnection. *See* Transmittal Letter at Section II.B.

6.3 Right to Observe Testing

[More than two Parties]

[Differences between APS LGIA and CAISO LGIA] The provision conforms to the CAISO LGIA since the CAISO provision is more specific.

6.4 Right to Inspect

[More than two Parties] and [Differences between APS LGIA and CAISO LGIA] The provision conforms to the CAISO LGIA's use of the word "another" to refer to Parties, since there are more than two Parties to the Agreement.

ARTICLE 7. METERING

7.1 General

[Need to make specific references (Transmission Provider) (Operating Agent of the JPP)]

[Differences between APS LGIA and CAISO LGIA] The provision refers to “Applicable Reliability Standards,” to conform to the CAISO LGIA. The provision omits CAISO LGIA references to specific CAISO metering requirements, as the CAISO’s requirements are consolidated in Article 7.6.

7.2 Check Meters

[Need to make specific references (Transmission Provider) (Operating Agent of the JPP)]

[Differences between APS LGIA and CAISO LGIA] This provision is based more on the APS LGIA.

Omission of CAISO LGIA Article 7.3

[Differences between APS LGIA and CAISO LGIA] The provisions of Article 7.3 of the CAISO LGIA are not necessary because APS will be providing any retail service and has its own provisions for retail metering.

7.3 Standards

[Need to make specific references (Operating Agent)]

[Differences between APS LGIA and CAISO LGIA] This provision is based on the APS LGIA.

7.4 Testing of Metering Equipment

[Need to make specific references (Transmission Provider) (Operating Agent of the JPP)]

[Differences between APS LGIA and CAISO LGIA] This provision is based on the APS LGIA.

7.5 Metering Data

[Need to make specific references (Transmission Provider)]

[Differences between APS LGIA and CAISO LGIA] The provision is based on the APS LGIA.

The applicability of this provision was limited by a cross-reference to Article 7.6 since Article 7.6 will apply to a project phase in the CAISO Balancing Authority Area. *See* Transmittal Letter at Section III.B.

7.6 Metering Requirements of CAISO

This is a new provision which provides the metering requirements for any project phase in the CAISO Balancing Authority Area. *See* Transmittal Letter at Section III.B.

ARTICLE 8. COMMUNICATIONS

8.1 Interconnection Customer Obligations

[Need to make specific references (Transmission Provider) (Operating Agent of the JPP) (Project Phase)]

[Differences between APS LGIA and CAISO LGIA] The provision omits CAISO LGIA references to specific CAISO operating communications requirements, as the CAISO's requirements are consolidated in Article 8.4.

See Transmittal Letter at Section III.B.

8.2 Remote Terminal Unit

[Need to make specific references (Transmission Provider) (Operating Agent of the JPP) (Parties) (Project Phase)]

[Differences between APS LGIA and CAISO LGIA] The provision omits CAISO LGIA references to specific CAISO telemetry requirements, as the CAISO's requirements are consolidated in Article 8.4.

See Transmittal Letter at Section III.B.

8.3 No Annexation

[Conforming to APS and CAISO LGIAs]

8.4 Communication Requirements of CAISO

This is a new provision which provides the communications requirements for any project phase in the CAISO Balancing Authority Area. *See* Transmittal Letter at Section III.B.

ARTICLE 9. OPERATIONS

9.1 General

[More than two Parties]

[Differences between APS LGIA and CAISO LGIA] The provision refers to "Applicable Reliability Standards," to conform to the CAISO LGIA.

9.2 Balancing Authority Area Notification

[Need for specific references (Transmission Provider)]

[Project phasing]

[Differences between APS LGIA and CAISO LGIA] The provision was modified to refer to “Applicable Reliability Standards,” an update which has been made in the CAISO LGIA.

Additional revisions were incorporated to simplify and clarify the wording of the provision as it applies to the circumstances of this Interconnection Customer. *See* Transmittal Letter at Section III.B.

9.3 Transmission Owner and CAISO Obligations

[Need for specific references (Transmission Provider) (Operating Agent of the JPP)] The APS LGIA version of this article refers generally to obligations of the “Transmission Provider” for the “Transmission System,” and the CAISO LGIA uses other terminology. Thus, this Article was modified to clarify the roles of the Parties. Specifically, all of the transmission owners and the CAISO have an obligation to make sure that their respective systems, and APS has the responsibility to make sure that the transmission owner interconnection facilities, are operated, maintained, and controlled in safe and reliable manner. However, only APS, acting on behalf of the transmission owners, and the CAISO are to provide operating instructions to the Interconnection Customer.

9.4 Interconnection Customer Obligations

[More than two Parties]

[Differences between APS LGIA and CAISO LGIA] The provision refers to “Balancing Authority” and “Balancing Authority Area,” rather than the “Control Area,” conforming to the CAISO LGIA. The CAISO LGIA provision requiring written approval of the transmission owner prior to commercial operation of a unit in parallel with the transmission system was omitted as covered separately by APS’ requirements as the utility constructing the interconnection facilities and network upgrades.

9.5 Start-Up and Synchronization

[Need to make specific references (Transmission System)]

9.6 Reactive Power

9.6.1 Power Factor Design Criteria

[Need to make specific references (Project Phase)] *See* Transmittal Letter at Section III.D.

9.6.2 Voltage Schedules

[Need to make specific references (Operating Agent of the JPP) (Transmission System)] *See* Transmittal Letter at Section III.D.

9.6.2.1 Governors and Regulators

[Need to make specific references (Transmission Provider)] *See* Transmittal Letter at Section III.D.

9.6.3 Payment for Reactive Power

[Need to make specific references (Transmission Provider)]

See Transmittal Letter at Section III.D.

9.7 Outages and Interruptions

9.7.1 Outages

9.7.1.1 Outage Authority and Coordination

[More than two Parties]

[Need for specific references (Parties) (Project Phases)]

See Transmittal Letter at Section III.C.

9.7.1.2 Outage Schedules

[Need to make specific references (Transmission Provider) (Operating Agent of the JPP) (Transmission System) (Project Phase)]

See Transmittal Letter at Section III.C.

9.7.1.3 Outage Restoration

[More than two Parties]

[Differences between APS LGIA and CAISO LGIA] The provision conforms to the CAISO LGIA.

9.7.2 Interruption of Service

[Need for specific references (Transmission Provider) (Operating Agent of the JPP) (Project Phases)]

See Transmittal Letter at Section III.C.

9.7.2.1

[Conforming to APS and CAISO LGIAs]

9.7.2.2

[Need to make specific references (Transmission System)]

9.7.2.3

[Need to make specific references (Transmission System)]

[Differences between APS LGIA and CAISO LGIA] The language “if requested by the Interconnection Customer” was incorporated, conforming to the CAISO LGIA. The provision was written to apply only to APS and not the CAISO, consistent with the introductory provisions in Article 9.7.2.

9.7.2.4

[Need to make specific references (Transmission Owner) (Operating Agent of the JPP) (Transmission System)]

[Differences between APS LGIA and CAISO LGIA] The provision was written to apply only to APS and not the CAISO, consistent with the introductory provisions in Article 9.7.2.

9.7.2.5

[Need to make specific references (Transmission System)]

9.7.3 Under-Frequency and Over Frequency Conditions

[Need to make specific references (Transmission Provider)]

[Differences between APS LGIA and CAISO LGIA] The provision refers to “Applicable Reliability Standards,” and uses the term “relay” rather than “protection,” to conform to the CAISO LGIA

9.7.4 System Protection and Other Control Requirements

9.7.4.1 System Protection Facilities

[Need to make specific references (Transmission Provider) (Transmission System)]

9.7.4.2

[Need to make specific references (Parties)]

[Differences between APS LGIA and CAISO LGIA] The provision was modified to refer to “Applicable Reliability Standards” and Applicable Reliability Council criteria, to conform to the CAISO LGIA.

9.7.4.3

[Need to make specific references (Parties)]

9.7.4.4

[Need to make specific references (Parties)]

9.7.4.5

[Need to make specific references (Parties)]

[Differences between APS LGIA and CAISO LGIA] Provisions of the CAISO LGIA were omitted because APS will be the constructing utility, and APS has its own interconnection requirements.

9.7.4.6

[Need to make specific references (Parties)]

[Differences between APS LGIA and CAISO LGIA] The provision refers to the “in-service date” rather than using the defined term “In-Service Date,” conforming to the CAISO LGIA. The term is intended to refer to the in-service date of the Special Protection Scheme, not the In-Service Date for the Generating Facility. Provisions of the CAISO LGIA were omitted because APS will be the constructing utility, and APS has its own interconnection requirements.

9.7.5 Requirements for Protection

[Need to make specific references (Transmission Providers) (Transmission System)]

[Differences between APS LGIA and CAISO LGIA] The provision refers to “a disconnecting device or switch with *fault current*-interrupting capability” rather than “a disconnecting device or switch with *load*-interrupting capability,” to conform to the CAISO LGIA. Provisions of the CAISO LGIA were omitted because APS will be the constructing utility, and APS has its own interconnection requirements.

9.7.6 Power Quality

[Differences between APS LGIA and CAISO LGIA] The provision refers to “Applicable Reliability Standards,” to conform to the CAISO LGIA, but omits the CAISO LGIA reference to “Applicable Reliability Council” standards as redundant.

9.8 Switching and Tagging Rules

[More than two Parties]

[Need to make specific references (Parties) (Operating Agent of the JPP)]

9.9 Use of Interconnection Facilities by Third Parties

9.9.1 Purpose of Interconnection Facilities

[Need to make specific references (Transmission System)]

9.9.2 Third Party Users

[Need to make specific references (Transmission Provider)]

The provision was modified with respect to the procedures to be followed to resolve disputes. Both the APS LGIA and CAISO LGIA provisions indicate only that disputes are to be resolved by FERC. The Parties modified the provision to also allow submission of complaints to arbitration in accordance with the provision of the Agreement. The Parties believe that providing this additional option makes the provision superior to both the APS LGIA and CAISO LGIA provisions since it gives the Parties an option which may reduce dispute resolution costs. Also, modifications to this language were necessary to reflect the fact that IID is not a public utility subject to FERC’s jurisdiction under Sections 205 or 206 of the Federal Power Act and, in view of IID’s status as a non-jurisdictional utility, to have an option for it other than solely recourse to a FERC dispute resolution process.

9.10 Disturbance Analysis Data Exchange

The provision refers just to the “Transmission Systems,” similar to the CAISO LGIA, since the term “Transmission Provider” in the APS LGIA is not used in this Agreement.

ARTICLE 10. MAINTENANCE

10.1 Transmission Owner Obligations

[Need to make specific references (Transmission Provider)]

10.2 Interconnection Customer Obligations

[No substantive change to APS or CAISO LGIA]

10.3 Coordination

[Need to make specific references (Parties) (Operating Agent of the JPP)]

The provision was modified to include a cross-reference to Article 9.7.1 of the Agreement in order to clarify the Agreement.

10.4 Secondary Systems

[More than two Parties]

[Need to make specific references (Parties) (Operating Agent of the JPP)]

10.5 Operating and Maintenance Expenses

[Need to make specific references (Transmission Provider)]

ARTICLE 11. PERFORMANCE OBLIGATION

11.1 Interconnection Customer Interconnection Facilities

[Need to make specific references (Project Phase)]

[Phasing of project]

11.2 Transmission Owners' Interconnection Facilities

[Need to make specific references (Transmission Provider) (Operating Agent of the JPP) (Project Phase)]

[Phasing of project]

[Differences between APS LGIA and CAISO LGIA] Provisions of the CAISO LGIA regarding funding of the interconnection facilities were omitted as covered by other provisions.

11.3 Network Upgrades and Distribution Upgrades

[Need to make specific references (Transmission Provider) (Operating Agent of the JPP) (Project Phase)]

[Differences between APS LGIA and CAISO LGIA] The APS LGIA language was changed in part to incorporate a provision similar to the CAISO LGIA, which requires allocation of the cost of network upgrades among multiple generators. The language incorporated clarifies the applicable references to the CAISO LGIP and omits the CAISO LGIA reference to the specification of cost responsibility in an appendix, as the CAISO LGIA limitation on cost responsibility does not apply to the circumstances of this Interconnection Customer and interconnection request. *See* Transmittal Letter at Section III.E.2.

11.4 Transmission Credits

For all of Article 11.4: [Need to make specific references (Transmission Provider) (Operating Agent of the JPP) (Project Phase)] Articles 11.4.1, 11.4.2, and 11.4.3 each are analogous to Article 11.4.1 of the APS and CAISO LGIAs, and correspond to APS, SDG&E, and IID, respectively.

[Differences between APS LGIA and CAISO LGIA] The CAISO LGIA provision specifying the Interconnection Customer's option to elect "Congestion Revenue Rights" in lieu of a refund of the cost of network upgrades has been omitted, as the Interconnection Customer has advised that it elects a refund of network upgrade costs.

11.4.1 Repayment of Amounts Advanced to APS for Network Upgrades to APS's Share of the JPP

See Transmittal Letter at Section III.E.4.

11.4.2 Repayment of Amounts Advanced to SDG&E for Network Upgrades to Its Share of the JPP and to Its Non-JPP Facilities

See Transmittal Letter at Section III.E.4.

11.4.3 Repayment of Amounts Advanced to IID for Network Upgrades to IID's Share of the JPP

See Transmittal Letter at Section III.E.4.

11.4.4 Special Provisions for Affected Systems

Article 11.4.4 of the Agreement corresponds to Article 11.4.2 of the APS and CAISO LGIAs.

See Transmittal Letter at Section II.B.

11.4.5

Article 11.4.5 of the Agreement corresponds to Article 11.4.3 of the APS and CAISO LGIAs.

[Differences between APS LGIA and CAISO LGIA] The provision was modified to refer to both “transmission congestion rights” as set forth in the APS LGIA and “Congestion Revenue Rights” as defined in the CAISO tariff, as among the rights not relinquished under the Agreement, to conform to both the CAISO LGIA and the APS LGIA.

11.5 Provision of Security (and subsections)

[Need to make specific references (Transmission Provider) (Operating Agent of the JPP) (Project Phase)]

See Transmittal Letter at Section III.E.1.

11.6 Interconnection Customer Compensation

This provision was modified since the generating technology to be utilized is such that the Interconnection Customer cannot provide reactive power. Thus, the cross-reference to Article 9.6.3, which pertains only to reactive power, has been eliminated. The cross reference to Article 13.5.1 has been retained since it refers generally to actions needed to address emergency conditions. *See* Transmittal Letter at Section III.D.2.

11.6.1 Interconnection Customer Compensation for Actions During Emergency Condition

[More than two Parties] Both the APS and CAISO LGIA provisions assume that only one transmission provider can require the Interconnection Customer to take action during emergency conditions. Since more than one party may be able to order the Interconnection Customer to take action under this Agreement, the provision was modified to make it clear that the party requesting the Interconnection Customer to provide service will provide compensation.

ARTICLE 12. INVOICE

12.1 General Provisions

[Need to make specific references (Transmission Provider) (Operating Agent of the JPP) (Parties) (Transmission System) (Project Phase)]

See Transmittal Letter at Section III.E.3.

12.2 Final Invoice

[Need to make specific references (Transmission Provider) (Operating Agent of the JPP) (Parties) (Transmission System) (Project Phase)]

[Differences between APS LGIA and CAISO LGIA] The APS LGIA provision requiring a final invoice within six months after completion of construction was incorporated rather than the CAISO LGIA provisions allowing twelve months for the final invoice, as APS will be the constructing utility.

See Transmittal Letter at Section III.E.3.

12.3 Payment

[Differences between APS LGIA and CAISO LGIA] The APS LGIA provision for payment was incorporated, with a non-substantive change, rather than the CAISO LGIA provision, as APS will be the constructing utility and will be primarily responsible for invoicing.

12.4 Disputes

[Need to make specific references (Transmission Provider)]

See Transmittal Letter at Section III.E.3.

ARTICLE 13. EMERGENCIES

13.1 Definition

[Differences between APS LGIA and CAISO LGIA] The definition of the term “Emergency Condition” in this article cross-references the definitions in Article 1 of the Agreement, similar to the CAISO LGIA. In the CAISO LGIA, the redundant definition is omitted and the Article reserved.

13.2 Obligations

This Article was modified to clarify the roles and responsibilities of the multiple Parties.

[Differences between APS LGIA and CAISO LGIA] Like the APS and CAISO LGIAs, this provision requires all Parties to comply with emergency condition procedures. This provision requires the Interconnection Customer, SDG&E, and the CAISO to comply with emergency condition procedures of the CAISO LGIA. Otherwise, this provision follows the APS LGIA, except that Parties must also comply with emergency condition procedures of “Applicable Reliability Standards,” as defined in the Agreement, and that any joint operating committee emergency condition procedures must be consistent with the other emergency condition procedures with which compliance is required. *See* Transmittal Letter at Section III.C.

13.3 Notice

[Need to make specific references (Transmission Provider) (Transmission System)]

[Differences between APS LGIA and CAISO LGIA] Language that relates to how written notice can be provided, if requested, has been incorporated to conform to the CAISO LGIA.

See Transmittal Letter at Section III.C.

13.4 Immediate Action

[Need to make specific references (Transmission Provider) (Operating Agent of the JPP)]

This provision is similar to the CAISO LGIA in making clear that the Parties will follow emergency condition procedures regardless of whether the emergency is declared by APS or by the CAISO.

See Transmittal Letter at Section III.C.

13.5 Transmission Owner and CAISO Authority

13.5.1 General

[Need to make specific references (Transmission Provider) (Operating Agent of the JPP)]

[Differences between APS LGIA and CAISO LGIA] The provision refers to “Applicable Reliability Standards,” to conform to the CAISO LGIA. Provisions of the CAISO LGIA were omitted as unnecessary for this Agreement.

The provision was modified to make the Interconnection Customer’s obligation to comply with operating instructions from APS subject to the provisions of Articles 9.6.1 and 9.6.2. This qualifier was necessary because in this Agreement Articles 9.6.1 and 9.6.2 set forth additional obligations with respect to real and reactive power output. *See* Transmittal Letter at Section III.C.

13.5.2 Reduction and Disconnection

[Need to make specific references (Transmission Provider) (Operating Agent of the JPP)]

The provision was modified to make a cross-reference to Articles 9.7.1 and 9.7.2, which require coordination by APS and the CAISO with respect to outages.

See Transmittal Letter at Section III.C.

13.6 Interconnection Customer Authority

[Need to make specific references (Transmission Provider)]

13.7 Limited Liability

[More than two Parties]

ARTICLE 14. REGULATORY REQUIREMENTS AND GOVERNING LAW

14.1 Regulatory Requirements

[More than two Parties]

[Differences between APS LGIA and CAISO LGIA] The CAISO LGIA reference to the Energy Policy Act of 2005 was omitted as non-essential.

14.2 Governing Law

14.2.1

[No substantive change to APS or CAISO LGIA]

14.2.2

[No substantive change to APS or CAISO LGIA]

14.2.3

[No substantive change to APS or CAISO LGIA]

ARTICLE 15. NOTICES

15.1 General

[More than two Parties]

[Differences between APS LGIA and CAISO LGIA] The CAISO LGIA provision permitting updating of contact information without having to amend the Agreement was incorporated to simplify the process of making changes to the Agreement.

15.2 Billings and Payments

[Conforming to APS and CAISO LGIAs]

15.3 Alternative Forms of Notice

[No substantive change to APS or CAISO LGIA]

15.4 Operations and Maintenance Notice

[More than two Parties]

[Need to include specific references (Parties)]

ARTICLE 16. FORCE MAJEURE

[More than two Parties]

ARTICLE 17. DEFAULT

17.1 Default

17.1.1 General

[More than two Parties]

The provision was modified because the Interconnection Customer consists of two corporate entities and to include posting of security as well as payment of money as not subject to excuse by *force majeure*, given its similar nature. *See* Transmittal Letter at Section III.F.2.

17.1.2 Right to Terminate

[More than two Parties]

The provision was modified to reference Article 11.5.3, as that article includes special provisions for curing a breach regarding posting of security. *See* Transmittal Letter at Section III.E.

ARTICLE 18. INDEMNITY, CONSEQUENTIAL DAMAGES AND INSURANCE

18.1 Indemnity

[More than two Parties]

[Differences between APS LGIA and CAISO LGIA] The APS LGIA uses the term “Indemnified Person” in the sub-Articles of Article 18.1, which is not defined in this Agreement. The CAISO LGIA uses the term “Indemnified Party.” In the Agreement, the word “Person” has been replaced with “Party” to conform to the CAISO LGIA. But, since the terms “Indemnified Party” and “Indemnifying Party” are not included in the definitions for either the APS LGIA or CAISO LGIA, the Parties to the Agreement have changed the initial capital letter in the term “Indemnified” and “Indemnifying” to the lower case to clarify the Agreement.

18.1.1 Indemnified Party

[Differences between APS LGIA and CAISO LGIA] See the explanation provided for Article 18.1.

18.1.2 Indemnifying Party

[Differences between APS LGIA and CAISO LGIA] See the explanation provided for Article 18.1.

18.1.3 Indemnity Procedures

[Differences between APS LGIA and CAISO LGIA] See the explanation provided for Article 18.1.

18.2 Consequential Damages

[More than two Parties]

The reference to liquidated damages was removed since the Parties have agreed that the Article pertaining to liquidated damages, Article 5.3, is not applicable to this Agreement.

18.3 Insurance (Articles 18.3.1 - 18.3.11 are discussed collectively below)

[More than two Parties]

[Differences between APS LGIA and CAISO LGIA]

Article 18.1 omits CAISO LGIA provisions as non-essential to the Agreement.

Article 18.3.1 incorporates CAISO LGIA provisions permitting the CAISO to maintain its insurance in California, since the CAISO is a party to the Agreement and as a non-profit public benefit corporation organized under the laws of the State of California maintains insurance in accordance with requirements of the State of California.

Articles 18.3.3 - 18.3.7 conform substantively to the CAISO LGIA in using the word “Comprehensive” rather than the word “Business,” as this is a more accurate description of the type of insurance coverage to be maintained by the Parties.

Article 18.3.9 conforms to the CAISO LGIA, referencing “Calendar Days” rather than “days” to ensure the clarity of the provision.

Article 18.3.10 conforms in large part to the CAISO LGIA, clarifying that “less than investment grade” means “unsecured debt rating and issuer rating are both rated at less than BBB- by Standard & Poor’s” (but omitting the CAISO LGIA reference to “unrated by Standard & Poor’s” as non-essential).

ARTICLE 19. ASSIGNMENT

[More than two Parties]

[Phasing of project]

ARTICLE 20. SEVERABILITY

[Need to make specific references (Transmission Provider)]

ARTICLE 21. COMPARABILITY

[Participation of IID] This article was clarified to reflect the fact that IID is not a public utility subject to FERC’s jurisdiction under Sections 205 or 206 of the Federal Power Act.

ARTICLE 22. CONFIDENTIALITY

22.1 Confidentiality

[More than two Parties]

22.1.1 Term

[No modification to APS LGIA]

22.1.2 Scope

[More than two Parties]

22.1.3 Release of Confidential Information

[Differences between APS LGIA and CAISO LGIA] The provision includes a specific citation to FERC’s Standards of Conduct regulations to conform to the CAISO LGIA.

22.1.4 Rights

[More than two Parties]

22.1.5 No Warranties

[More than two Parties]

22.1.6 Standard of Care

[More than two Parties]

22.1.7 Disclosure Required by Law or Order

[More than two Parties]

[Participation of IID] This provision was modified to reflect the fact that, as a political subdivision of the State of California, IID may be legally compelled to disclose information in accordance with the California Public Records Act.

The title of this provision was modified to reflect that disclosures under this section may if required by law regardless of whether there is an “order.”

22.1.8 Termination of Agreement

[More than two Parties]

22.1.9 Remedies

[More than two Parties]

22.1.10 Disclosure to FERC, its Staff, or a State

[More than two Parties]

22.1.11

[More than two Parties]

[Differences between APS LGIA and CAISO LGIA]:

- The provision makes clear that it applies to “Confidential Information” as that term is defined in Article 1 of the Agreement to conform to the CAISO LGIA.
- The provision refers to “Balancing Authority” and “Balancing Authority Area,” rather than the “Control Area,” to conform to the CAISO LGIA.

ARTICLE 23. ENVIRONMENTAL RELEASES

[More than two Parties]

ARTICLE 24. INFORMATION REQUIREMENTS

24.1 Information Acquisition

[Need to make specific references (Transmission Provider) (Operating Agent of the JPP)]

24.2 Information Submission by APS, on behalf of Transmission Owners

[Need to make specific references (Transmission Provider) (Operating Agent of the JPP)]

[Phasing of project]

24.3 Updated Information Submission by Interconnection Customer

[Need to make specific references]

[Phasing of project]

The provision was modified because the Parties desired a comprehensive agreement which includes provisions for IID’s non-JPP facilities where affected by the proposed interconnection. *See* Transmittal Letter at Section II.B.

24.4 Information Supplementation

[Need to make specific references (Operating Agent of the JPP)]

[Phrasing of project]

[Differences between APS LGIA and CAISO LGIA] The change at the end of the second paragraph removes language which suggests that testing shall be “for each individual generating unit in a station.” It is not clear what this would mean for a solar photovoltaic facility. The language at the end of the Article omits a notice requirement in favor of a cross reference to Article 5.19 which covers the same subject matter, consistent with the CAISO LGIA. This is a desirable change to avoid confusion regarding whether it is necessary to comply with each of the notice requirements.

ARTICLE 25. INFORMATION ACCESS AND AUDIT RIGHTS

25.1 Information Access

[More than two Parties]

[Differences between APS LGIA and CAISO LGIA] The language at the end of this Article, which states that Parties shall not use information gained under this provision for purposes other than those set forth in Article 25.1, is consistent with the language of the CAISO LGIA.

25.2 Reporting of Non-Force Majeure Events

[More than two Parties]

25.3 Audit Rights

[More than two Parties]

[Need to make specific references (Transmission Provider)]

[Differences between APS LGIA and CAISO LGIA] The language at the end this Article is consistent with language in the CAISO LGIA. This is desirable since it makes it clear that the Article does not supersede requirements of the applicable tariffs. The article omits the reorganization of its provisions in the CAISO LGIA as non-essential to this Agreement.

25.4 Audit Rights Periods

25.4.1 Audit Rights Period for Construction-Related Accounts and Records

[Need to make specific references (Transmission Provider) (Operating Agent of the JPP)]

[Differences between APS LGIA and CAISO LGIA] This provision omits CAISO LGIA language regarding audit of Interconnection Customer construction of transmission owner interconnection facilities and stand-alone network upgrades, as the Interconnection Customer does not plan to build the former and there are none of the latter.

25.4.2 Audit Rights Period for All Other Accounts and Records

[Differences between APS LGIA and CAISO LGIA] CAISO LGIA provisions were omitted as covered sufficiently by Article 25.3.

25.5 Audit Results

[More than two Parties]

[Differences between APS LGIA and CAISO LGIA] CAISO LGIA provisions were omitted as covered sufficiently by other provisions.

ARTICLE 26. SUBCONTRACTORS

26.1 General

[No substantive change to APS or CAISO LGIA]

26.2 Responsibility of Principal

[No substantive change to APS or CAISO LGIA]

26.3 No Limitation by Insurance

[Conforming to APS and CAISO LGIAs]

ARTICLE 27. DISPUTES

This provision was incorporated similar to the CAISO LGIA because the CAISO is a party to the Agreement and, thus, if there is a dispute involving the CAISO, the CAISO will need to follow the dispute resolution procedures set out in the CAISO tariff. The CAISO LGIA provisions were modified to limit the applicability of the CAISO tariff procedures only to disputes between the CAISO, the Interconnection Customer, and/or SDG&E, and special provisions were included to cover certain disputes between the Interconnection Customer and IID, in order to make clear that neither APS nor IID is subject to the CAISO tariff procedures.

27.1 Submission

[More than two Parties]

27.2 External Arbitration Procedures

The APS and CAISO LGIA provisions were modified to leave as the only option the selection of a single arbitrator. The alternative procedure for selecting a panel of three arbitrators was eliminated because it does not appear to be workable for this Agreement. This alternative procedure assumes two parties will each select an arbitrator and agree on a third. But, there are more than two Parties to the Agreement, there are six.

27.3 Arbitration Decisions

[No substantive change to APS or CAISO LGIA]

27.4 Costs

[Multiple Parties]

This provision was modified to make it consistent with the changes made to Article 27.2, regarding external arbitration procedures, and to make it clear how costs would be divided in light of the multiple Parties involved.

ARTICLE 28. REPRESENTATIONS, WARRANTIES, AND COVENANTS

28.1 General

[No substantive change to APS or CAISO LGIA]

28.1.1 Good Standing

[No substantive change to APS or CAISO LGIA]

28.1.2 Authority

[No substantive change to APS or CAISO LGIA]

28.1.3 No Conflict

[No substantive change to APS or CAISO LGIA]

28.1.4 Consent and Approval

[No substantive change to or CAISO APS LGIA]

ARTICLE 29. JOINT OPERATING COMMITTEE

[Need to make specific references (Transmission Provider) (Operating Agent of the JPP)]

[Differences between APS LGIA and CAISO LGIA] While the CAISO LGIA omits this provision, this provision was incorporated to be consistent with the APS LGIA. The transmission owners and the CAISO recognize that as operating agent under the Participation Agreement, it is appropriate for APS to have responsibility for matters relating to the joint operating committee.

ARTICLE 30. MISCELLANEOUS

30.1 Binding Effect

[No substantive change to APS or CAISO LGIA]

30.2 Conflicts

[No substantive change to APS or CAISO LGIA]

30.3 Rules of Interpretation

[No substantive change to APS or CAISO LGIA]

30.4 Entire Agreement

The provision was clarified because the Parties desired a comprehensive agreement which includes provisions for IID's non-JPP facilities and to reflect the fact that an Affected System Study Agreement and potentially an Affected System Construction and Operation Agreement are expected to be executed between IID and the Interconnection Customer to address impacts on those facilities and the upgrades, if any, that are required as a result of the proposed interconnection..

See Transmittal Letter at Section II.B.

30.5 No Third Party Beneficiaries

[No substantive change to APS or CAISO LGIA]

30.6 Waiver

[Need to make specific references (Transmission Provider)]

30.7 Headings

[No substantive change to APS or CAISO LGIA]

30.8 Multiple Counterparts

[No substantive change to APS or CAISO LGIA]

30.9 Amendment

[Differences between APS LGIA and CAISO LGIA] This provision incorporates language consistent with the CAISO LGIA. The CAISO LGIA language provides greater clarity regarding when an amendment to the Agreement is to take effect.

30.10 Modification by the Parties

[No substantive change to APS or CAISO LGIA]

30.11 Reservation of Rights

[Participation by IID]

[Differences between APS LGIA and CAISO LGIA] The CAISO LGIA provisions allocating the right to make a unilateral filing with the Commission on a provision-by-provision basis were omitted as non-essential to this Agreement.

30.12 No Partnership

[More than two Parties]

30.13 Joint and Several Obligations

[Differences between APS LGIA and CAISO LGIA] This provision is not a part of the APS LGIA, but a similar provision appears in the CAISO LGIA. The CAISO LGIA provision was modified to reflect the relationship between companies that are the Interconnection Customer. *See* Transmittal Letter at Section III.F.2.

APPENDICES

Appendix A-1	Interconnection Facilities, JPP Network Upgrades, and Distribution Upgrades for Phase A of the Interconnection Project
Appendix A-2	Interconnection Facilities, JPP Network Upgrades, and Distribution Upgrades for Phase B of the Interconnection Project
Appendix A-3	SDG&E Network Upgrades for Phase B of the Interconnection Project

Appendix A of the APS and CAISO LGIAs was modified by dividing it into separate appendices for Phase A of the Interconnection Project, Phase B of the Interconnection Project, and possible SDG&E network upgrades for Phase B. This was done since there are significant differences between these three related projects and how the projects will proceed to implementation. Keeping the projects separate makes it easier to understand how each is to be implemented. (*See* Transmittal Letter at Sections I.C, III.D.1.)

These appendices include the following clarifying provisions:

Appendix A-1, Section 13: Provisions clarifying the transition from the Engineering & Procurement Agreement to this Agreement;

Appendix A-1, Section 14 and Appendix A-2, Section 13: Provisions clarifying the procedures for handling financial security (*see* Transmittal Letter at Section III.E); and

Appendix A-1, Section 16: Provisions clarifying the treatment of the CAISO Phase II Interconnection Study report in relation to the provisions of the Agreement (*see* Transmittal Letter at Section III.E.1 [in relation to discussion of Article 11.5]).

Appendix B-1	Milestones for Interconnection Facilities and JPP Network Upgrades for Phase A of the Interconnection Project
Appendix B-2	Milestones for Interconnection Facilities and JPP Network Upgrades for Phase B of the Interconnection Project
Appendix B-3	Milestones for SDG&E Network Upgrades for Phase B of the Interconnection Project

Appendix B of the APS and CAISO LGIAs was modified by dividing it into separate milestone schedules for Phase A of the Interconnection Project, Phase B of the Interconnection Project, and possible SDG&E network upgrades for Phase B. This was done since there are significant differences between the milestones that are applicable to these three related projects. Keeping the milestone schedules for each separate makes it easier to understand the milestones for each of the three projects. (*See* Transmittal Letter at III.D.1.)

Appendix C Interconnection Details

In addition to the provisions describing the interconnection, this appendix includes the following clarifying provisions:

Section 3: This provision clarifies that APS is entitled to review all agreements between the Interconnection Customer and other Balancing Authorities if a project phase is to be in another Balancing Authority Area. (*See Transmittal Letter at Section III.B.*)

Section 4: This provision sets forth additional conditions that are to be met for construction of Phase B of the Interconnection Project, which include conditions relating to possible additional interconnection studies by CAISO and IID and, if such studies show a need for additional facilities, possible amended or new agreements to construct the needed facilities. (*See Transmittal Letter at Section III.G.1.*)

Section 5: This provision makes it clear that the two entities that comprise the Interconnection Customer shall be jointly and severally liable for all obligations required of the Interconnection Customer under the Agreement. (*See Transmittal Letter at Section III.F.2.*)

Section 6: This provision requires the two entities that comprise the Interconnection Customer to appoint a single spokesperson who shall serve as the Interconnection Customer's authorized agent and representative for purposes of administering the Agreement. (*See Transmittal Letter at Section III.F.1.*)

Section 7: This provision specifies that if the conditions for construction of Phase B of the Interconnection Project have been met, the Interconnection Customer is to determine whether obtaining financing on commercially reasonable terms will require separate LGIAs for each project phase, and, if so, commits the Parties to enter into good faith negotiations to separate the obligations in the Agreement into separate LGIAs for each project phase. (*See Transmittal Letter at Sections III.F.2, III.G.2.*)

Section 8: This provision gives North Gila the right to terminate Phase B of the Generating Facility, provided that it remains liable for construction of network upgrades if termination constitutes a material modification, and, in the event North Gila exercises this right, commits the Parties to amend the Agreement to remove Phase B of the Generating Facility. (*See Transmittal Letter at Section III.G.3.*)

Appendix D Security Arrangements Details

[Differences between APS LGIA and CAISO LGIA] This Appendix includes a second paragraph from the CAISO LGIA imposing additional requirements for a project phase for which the Interconnection Customer selects the CAISO Balancing Authority Area. In particular, the added language requires the Interconnection Customer to comply with requirements for security of the CAISO tariff including the CAISO's standard for information security.

Appendix E Commercial Operation Date

[Differences between APS LGIA and CAISO LGIA] The Appendix was modified to refer to completion of all Project Blocks within a project phase, in accordance with the implementation plan for multiple Project Blocks. This accommodates the solar photovoltaic technology used for the Generating Facility, and is consistent with the CAISO LGIA's recognition that generating projects could achieve commercial operation in multiple phases. *See also* overall subject matter description of modifications made in the Transmittal Letter at Section III.D. The appendix also incorporates the CAISO LGIA requirement for confirmation that the Interconnection Customer provided the CAISO five days advance notice of its intended operation date.

Appendix F Addresses for Delivery of Notices and Billings

[Conforming to APS and CAISO LGIAs]

Omission of CAISO LGIA Appendix G

[Differences between APS LGIA and CAISO LGIA] The CAISO LGIA Appendix G providing for a specification of the Interconnection Customer's cost responsibility was omitted, as the CAISO LGIA limitation on cost responsibility does not apply to the circumstances of this Interconnection Customer and interconnection request.

Appendix G Requirements of a Wind Generating Plant [CAISO LGIA Appendix H]

This appendix was omitted since it is not applicable to this Agreement. The Generating Facility is not a wind generation facility.

Appendix H Reliability Management System Agreement

[Differences between APS LGIA and CAISO LGIA] The CAISO LGIA omits this form of agreement as not necessary for the CAISO or SDG&E to enter into, but it has been included for use by APS. This Appendix was modified from the APS LGIA by substituting a more recent version of the Reliability Management System Agreement, which is an agreement developed by WECC.

ATTACHMENT B-1

Service Agreement No. 303

under

**Arizona Public Service Company
FERC Electric Tariff, Fourteenth Revised Volume No. 2**

LARGE GENERATOR INTERCONNECTION AGREEMENT

BY AND BETWEEN

AGUA CALIENTE SOLAR, LLC, AND NORTH GILA RIVER DEVELOPMENT, LLC
AS INTERCONNECTION CUSTOMER

AND

ARIZONA PUBLIC SERVICE COMPANY,

IMPERIAL IRRIGATION DISTRICT,

SAN DIEGO GAS & ELECTRIC COMPANY, AND

CALIFORNIA INDEPENDENT SYSTEM OPERATOR CORPORATION

TABLE OF CONTENTS

	Page
RECITALS	1
ARTICLE 1 DEFINITIONS	3
ARTICLE 2 EFFECTIVE DATE, TERM, AND TERMINATION	11
2.1 EFFECTIVE DATE.	11
2.2 TERM OF AGREEMENT	12
2.3 TERMINATION PROCEDURES	12
2.3.1 WRITTEN NOTICE	12
2.3.2 DEFAULT	12
2.4 TERMINATION COSTS.....	12
2.5 DISCONNECTION	14
2.6 SURVIVAL	14
ARTICLE 3. REGULATORY FILINGS	14
3.1 FILING.....	15
ARTICLE 4. SCOPE OF SERVICE.....	15
4.1 INTERCONNECTION PRODUCT OPTIONS.....	15
4.1.1 CAISO INTERCONNECTION SERVICE	15
4.1.2 ENERGY RESOURCE INTERCONNECTION SERVICE.....	15
4.1.2.1 THE PRODUCT	15
4.1.2.2 TRANSMISSION DELIVERY SERVICE IMPLICATIONS.....	15
4.1.3 NETWORK RESOURCE INTERCONNECTION SERVICE.....	16
4.1.3.1 THE PRODUCT	16
4.1.3.2 TRANSMISSION DELIVERY SERVICE IMPLICATIONS.....	16
4.2 PROVISION OF SERVICE	16
4.3 PERFORMANCE STANDARDS	16
4.4 NO TRANSMISSION DELIVERY SERVICE	16
4.5 INTERCONNECTION CUSTOMER PROVIDED SERVICES	16
ARTICLE 5. INTERCONNECTION FACILITIES ENGINEERING, PROCUREMENT, AND CONSTRUCTION	16
5.1 OPTIONS.....	17
5.1.1 STANDARD OPTION.....	17

5.1.2	ALTERNATE OPTION	17
5.1.3	OPTION TO BUILD	17
5.1.4	NEGOTIATED OPTION.....	17
5.2	GENERAL CONDITIONS APPLICABLE TO OPTION TO BUILD.....	17
5.3	LIQUIDATED DAMAGES.....	17
5.4	POWER SYSTEM STABILIZERS	17
5.5	EQUIPMENT PROCUREMENT.....	18
5.6	CONSTRUCTION COMMENCEMENT.....	18
5.7	WORK PROGRESS.....	18
5.8	INFORMATION EXCHANGE	19
5.9	LIMITED OPERATION.....	19
5.10	INTERCONNECTION CUSTOMER’S INTERCONNECTION FACILITIES (‘ICIF’).....	19
5.10.1	INTERCONNECTION CUSTOMER’S INTERCONNECTION FACILITY SPECIFICATIONS	19
5.10.2	REVIEW BY TRANSMISSION OWNERS AND CAISO.....	19
5.10.3	ICIF CONSTRUCTION	20
5.11	TRANSMISSION OWNERS’ INTERCONNECTION FACILITIES CONSTRUCTION.....	20
5.12	ACCESS RIGHTS	20
5.13	LANDS OF OTHER PROPERTY OWNERS	21
5.14	PERMITS.....	21
5.15	EARLY CONSTRUCTION OF BASE CASE FACILITIES.....	21
5.16	SUSPENSION.....	21
5.17	TAXES.....	22
5.17.1	INTERCONNECTION CUSTOMER PAYMENTS NOT TAXABLE	22
5.17.2	REPRESENTATIONS AND COVENANTS	22
5.17.3	INDEMNIFICATION FOR THE COST CONSEQUENCES OF CURRENT TAX LIABILITY IMPOSED UPON THE TRANSMISSION OWNER.....	23
5.17.4	TAX GROSS-UP AMOUNT.....	23
5.17.5	PRIVATE LETTER RULING OR CHANGE OR CLARIFICATION OF LAW	24
5.17.6	SUBSEQUENT TAXABLE EVENTS	24
5.17.7	CONTESTS.....	24
5.17.8	REFUND	25

5.17.9	TAXES OTHER THAN INCOME TAXES.....	26
5.18	TAX STATUS	27
5.19	MODIFICATION.....	27
5.19.1	GENERAL	27
5.19.2	STANDARDS	28
5.19.3	MODIFICATION COSTS	28
ARTICLE 6.	TESTING AND INSPECTION.....	28
6.1	PRE-COMMERCIAL OPERATION DATE TESTING AND MODIFICATIONS	28
6.2	POST-COMMERCIAL OPERATION DATE TESTING AND MODIFICATIONS	29
6.3	RIGHT TO OBSERVE TESTING.....	29
6.4	RIGHT TO INSPECT	29
ARTICLE 7.	METERING	29
7.1	GENERAL	29
7.2	CHECK METERS	30
7.3	STANDARDS	30
7.4	TESTING OF METERING EQUIPMENT	30
7.5	METERING DATA	30
7.6	METERING REQUIREMENTS OF CAISO.....	30
ARTICLE 8.	COMMUNICATIONS.....	31
8.1	INTERCONNECTION CUSTOMER OBLIGATIONS	31
8.2	REMOTE TERMINAL UNIT	31
8.3	NO ANNEXATION	32
8.4	COMMUNICATION REQUIREMENTS OF CAISO.....	32
ARTICLE 9.	OPERATIONS	32
9.1	GENERAL	32
9.2	BALANCING AUTHORITY AREA NOTIFICATION.....	32
9.3	TRANSMISSION OWNER AND CAISO OBLIGATIONS	32
9.4	INTERCONNECTION CUSTOMER OBLIGATIONS	32
9.5	START-UP AND SYNCHRONIZATION.....	33
9.6	REACTIVE POWER	33
9.6.1	POWER FACTOR DESIGN CRITERIA	33
9.6.2	VOLTAGE SCHEDULES	33

9.6.2.1	GOVERNORS AND REGULATORS.....	34
9.6.3	PAYMENT FOR REACTIVE POWER.....	34
9.7	OUTAGES AND INTERRUPTIONS.....	34
9.7.1	OUTAGES	34
9.7.1.1	OUTAGE AUTHORITY AND COORDINATION.....	34
9.7.1.2	OUTAGE SCHEDULES	35
9.7.1.3	OUTAGE RESTORATION.....	35
9.7.2	INTERRUPTION OF SERVICE.....	36
9.7.3	UNDER-FREQUENCY AND OVER FREQUENCY CONDITIONS.....	37
9.7.4	SYSTEM PROTECTION AND OTHER CONTROL REQUIREMENTS.....	37
9.7.4.1	SYSTEM PROTECTION FACILITIES	37
9.7.5	REQUIREMENTS FOR PROTECTION.....	38
9.7.6	POWER QUALITY.....	38
9.8	SWITCHING AND TAGGING RULES.....	38
9.9	USE OF INTERCONNECTION FACILITIES BY THIRD PARTIES.....	38
9.9.1	PURPOSE OF INTERCONNECTION FACILITIES	39
9.9.2	THIRD PARTY USERS	39
9.10	DISTURBANCE ANALYSIS DATA EXCHANGE.....	39
ARTICLE 10.	MAINTENANCE.....	39
10.1	TRANSMISSION OWNER OBLIGATIONS.....	39
10.2	INTERCONNECTION CUSTOMER OBLIGATIONS	39
10.3	COORDINATION.....	39
10.4	SECONDARY SYSTEMS	40
10.5	OPERATING AND MAINTENANCE EXPENSES.....	40
ARTICLE 11.	PERFORMANCE OBLIGATION.....	40
11.1	INTERCONNECTION CUSTOMER INTERCONNECTION FACILITIES.....	40
11.2	TRANSMISSION OWNERS' INTERCONNECTION FACILITIES	40
11.3	NETWORK UPGRADES AND DISTRIBUTION UPGRADES.....	40
11.4	TRANSMISSION CREDITS	40
11.4.1	REPAYMENT OF AMOUNTS ADVANCED TO APS FOR NETWORK UPGRADES TO APS'S SHARE OF THE JPP.....	40

11.4.2	REPAYMENT OF AMOUNTS ADVANCED TO SDG&E FOR NETWORK UPGRADES TO ITS SHARE OF THE JPP AND TO ITS NON-JPP FACILITIES	41
11.4.3	REPAYMENT OF AMOUNTS ADVANCED TO IID FOR NETWORK UPGRADES TO IID’S SHARE OF THE JPP.....	42
11.4.4	SPECIAL PROVISIONS FOR AFFECTED SYSTEMS	43
11.5	PROVISION OF SECURITY.....	44
11.6	INTERCONNECTION CUSTOMER COMPENSATION.....	46
11.6.1	INTERCONNECTION CUSTOMER COMPENSATION FOR ACTIONS DURING EMERGENCY CONDITION.....	46
ARTICLE 12.	INVOICE	46
12.1	GENERAL PROVISIONS	46
12.2	FINAL INVOICE.....	47
12.3	PAYMENT.....	47
12.4	DISPUTES	47
ARTICLE 13.	EMERGENCIES	48
13.1	DEFINITION	48
13.2	OBLIGATIONS.....	48
13.3	NOTICE	48
13.4	IMMEDIATE ACTION.....	48
13.5	TRANSMISSION OWNER AND CAISO AUTHORITY	49
13.5.1	GENERAL	49
13.5.2	REDUCTION AND DISCONNECTION.....	49
13.6	INTERCONNECTION CUSTOMER AUTHORITY	50
13.7	LIMITED LIABILITY	50
ARTICLE 14.	REGULATORY REQUIREMENTS AND GOVERNING LAW	50
14.1	REGULATORY REQUIREMENTS.....	50
14.2	GOVERNING LAW.....	50
ARTICLE 15.	NOTICES.....	50
15.1	GENERAL	50
15.2	BILLINGS AND PAYMENTS.....	51
15.3	ALTERNATIVE FORMS OF NOTICE	51
15.4	OPERATIONS AND MAINTENANCE NOTICE.....	51

ARTICLE 16.	FORCE MAJEURE.....	51
ARTICLE 17.	DEFAULT	51
17.1	DEFAULT	51
17.1.1	GENERAL	51
17.1.2	RIGHT TO TERMINATE.....	52
ARTICLE 18.	INDEMNITY, CONSEQUENTIAL DAMAGES AND INSURANCE.....	52
18.1	INDEMNITY	52
18.1.1	INDEMNIFIED PARTY	52
18.1.2	INDEMNIFYING PARTY	52
18.1.3	INDEMNITY PROCEDURES	52
18.2	CONSEQUENTIAL DAMAGES.....	53
18.3	INSURANCE	53
ARTICLE 19.	ASSIGNMENT	55
ARTICLE 20.	SEVERABILITY	55
ARTICLE 21.	COMPARABILITY	56
ARTICLE 22.	CONFIDENTIALITY	56
22.1	CONFIDENTIALITY	56
22.1.1	TERM	56
22.1.2	SCOPE	56
22.1.3	RELEASE OF CONFIDENTIAL INFORMATION	57
22.1.4	RIGHTS.....	57
22.1.5	NO WARRANTIES	57
22.1.6	STANDARD OF CARE	57
22.1.7	DISCLOSURE REQUIRED BY LAW OR ORDER	57
22.1.8	TERMINATION OF AGREEMENT	58
22.1.9	REMEDIES	58
22.1.10	DISCLOSURE TO FERC, ITS STAFF, OR A STATE.....	58
ARTICLE 23.	ENVIRONMENTAL RELEASES.....	59
ARTICLE 24.	INFORMATION REQUIREMENTS	59
24.1	INFORMATION ACQUISITION	59
24.2	INFORMATION SUBMISSION BY APS, ON BEHALF OF TRANSMISSION OWNERS.....	59
24.3	UPDATED INFORMATION SUBMISSION BY INTERCONNECTION CUSTOMER.....	59

24.4	INFORMATION SUPPLEMENTATION.....	60
ARTICLE 25.	INFORMATION ACCESS AND AUDIT RIGHTS	61
25.1	INFORMATION ACCESS.....	61
25.2	REPORTING OF NON-FORCE MAJEURE EVENTS.....	61
25.3	AUDIT RIGHTS	61
25.4	AUDIT RIGHTS PERIODS	61
	25.4.1 AUDIT RIGHTS PERIOD FOR CONSTRUCTION-RELATED ACCOUNTS AND RECORDS.....	62
	25.4.2 AUDIT RIGHTS PERIOD FOR ALL OTHER ACCOUNTS AND RECORDS	62
25.5	AUDIT RESULTS	62
ARTICLE 26.	SUBCONTRACTORS.....	62
26.1	GENERAL	62
26.2	RESPONSIBILITY OF PRINCIPAL	62
26.3	NO LIMITATION BY INSURANCE	62
ARTICLE 27.	DISPUTES	62
27.1	SUBMISSION.....	63
27.2	EXTERNAL ARBITRATION PROCEDURES.....	63
27.3	ARBITRATION DECISIONS.....	63
27.4	COSTS	63
ARTICLE 28.	REPRESENTATIONS, WARRANTIES, AND COVENANTS	63
28.1	GENERAL	64
	28.1.1 GOOD STANDING	64
	28.1.2 AUTHORITY	64
	28.1.3 NO CONFLICT	64
	28.1.4 CONSENT AND APPROVAL.....	64
ARTICLE 29.	JOINT OPERATING COMMITTEE.....	64
ARTICLE 30.	MISCELLANEOUS	65
30.1	BINDING EFFECT.....	65
30.2	CONFLICTS.....	65
30.3	RULES OF INTERPRETATION	65
30.4	ENTIRE AGREEMENT.....	66
30.5	NO THIRD PARTY BENEFICIARIES	66

30.6	WAIVER	66
30.7	HEADINGS	66
30.8	MULTIPLE COUNTERPARTS	66
30.9	AMENDMENT	66
30.10	MODIFICATION BY THE PARTIES	66
30.11	RESERVATION OF RIGHTS	67
30.12	NO PARTNERSHIP.....	67
30.13	JOINT AND SEVERAL OBLIGATIONS.....	67

APPENDICES

Appendix A-1	Interconnection Facilities, JPP Network Upgrades, and Distribution Upgrades for Phase A of the Interconnection Project
Appendix A-2	Interconnection Facilities, JPP Network Upgrades, and Distribution Upgrades for Phase B of the Interconnection Project
Appendix A-3	SDG&E Network Upgrades for Phase B of the Interconnection Project
Appendix B-1	Milestones for Interconnection Facilities and JPP Network Upgrades for Phase A of the Interconnection Project
Appendix B-2	Milestones for Interconnection Facilities and JPP Network Upgrades for Phase B of the Interconnection Project
Appendix B-3	Milestones for SDG&E Network Upgrades for Phase B of the Interconnection Project
Appendix C	Interconnection Details
Appendix D	Security Arrangements Details
Appendix E	Commercial Operation Date
Appendix F	Addresses for Delivery of Notices and Billings
Appendix G	Requirements of a Wind Generating Plant
Appendix H	Reliability Management System Agreement

LARGE GENERATOR INTERCONNECTION AGREEMENT

THIS LARGE GENERATOR INTERCONNECTION AGREEMENT

("Agreement") is made and entered into this ____ day of _____ 20__, by and between Agua Caliente Solar, LLC, to which NextLight Renewable Power, LLC ("NextLight") has duly assigned its Interconnection Requests only as to Phase A of the Generating Facility, and North Gila River Development, LLC, to which NextLight has duly assigned its Interconnection Request submitted only to APS only as to Phase B of the Generating Facility, each of which is a corporation organized and existing under the laws of the State of Delaware, (collectively Agua Caliente Solar, LLC and North Gila River Development, LLC are the "Interconnection Customer" with a Large Generating Facility), and Arizona Public Service Company ("APS"), a corporation organized and existing under the laws of the State of Arizona, Imperial Irrigation District ("IID"), an irrigation district organized under the Water Code of the State of California, San Diego Gas & Electric Company ("SDG&E"), a corporation organized under the laws of the State of California, and California Independent System Operator Corporation ("CAISO"), a nonprofit public benefit corporation organized and existing under the laws of California. Interconnection Customer, APS, IID, SDG&E and CAISO each may be referred to as a "Party" or collectively as the "Parties."

Recitals

WHEREAS, APS and SDG&E entered into the Arizona Transmission System Participation Agreement, dated June 24, 1981 ("Participation Agreement");

WHEREAS, APS, IID, and SDG&E entered into Amendment No. 1 to the Participation Agreement, dated January 22, 1985 ("Amendment No. 1"), pursuant to which SDG&E assigned and transferred an undivided interest in the Arizona Transmission System to IID;

WHEREAS, APS, IID, and SDG&E ("Joint Participants" or "Transmission Owners") own the Joint Participation Project ("JPP") as set forth in the Participation Agreement, amended by Amendment No. 1;

WHEREAS, APS acts as the Operating Agent of the JPP pursuant to the Participation Agreement, as amended;

WHEREAS, APS and the CAISO are parties to the Interconnected Control Area Operating Agreement, dated November 26, 1997;

WHEREAS, APS, IID, SDG&E, and the CAISO provide transmission service on their respective Transmission Systems;

WHEREAS, Interconnection Customer intends to own, lease and/or control and operate the Generating Facility identified as a Large Generating Facility in Appendix C to this Agreement;

WHEREAS, NextLight, submitted an Interconnection Request for such Large Generating Facility to APS on February 22, 2008, and also submitted an Interconnection Request for Phase A of the Large Generating Facility to CAISO on June 2, 2008;

WHEREAS, NextLight and APS, on behalf of the Joint Participants, entered into an Engineering & Procurement Agreement dated March 30, 2010, to begin design and procurement work for certain Interconnection Facilities to be constructed pursuant to this Agreement and NextLight duly assigned the Engineering & Procurement Agreement to Agua Caliente Solar, LLC;

WHEREAS, the Parties have agreed to enter into this Agreement for the purpose of interconnecting the Large Generating Facility with the JPP; and

WHEREAS, all Parties that are public utilities subject to the jurisdiction of the Federal Energy Regulatory Commission (“FERC”) will file this Agreement simultaneously, as a service agreement under their respective Tariffs.

NOW, THEREFORE, in consideration of and subject to the mutual covenants contained herein, it is agreed:

When used in this Agreement, terms with initial capitalization that are not defined in Article 1 shall have the meanings specified in the Article in which they are used or in the APS Open Access Transmission Tariff or the CAISO Tariff, as applicable.

When an Article of this Agreement contains the phrase “THIS ARTICLE IS NOT APPLICABLE TO THIS AGREEMENT,” or “THIS SECTION IS NOT APPLICABLE TO THIS AGREEMENT,” or “THIS PARAGRAPH IS NOT APPLICABLE TO THIS AGREEMENT,” or when an Appendix to this Agreement contains the phrase “THIS APPENDIX IS NOT APPLICABLE TO THIS AGREEMENT,” the Article, Section, Paragraph or Appendix will have no force and effect with respect to this Agreement.

Article 1. Definitions

Adverse System Impact shall mean the negative effects due to technical or operational limits on conductors or equipment being exceeded that may compromise the safety and reliability of the electric system.

Affected System shall mean an electric system other than the APS or SDG&E's Transmission Systems or IID's share of the JPP that may be affected by the proposed interconnection.

Affected System Operator shall mean the entity that operates an Affected System.

Affected System Construction and Operation Agreement shall mean an agreement between the Interconnection Customer and IID to pay the costs of Network Upgrades, for either of the Project Phases, to IID's Transmission System, other than IID's share of the JPP, and to provide for repayment of amounts advanced to IID with transmission rate credits when transmission service is taken on IID's Transmission System.

Affected System Study shall mean an engineering study that evaluates the impacts of the proposed interconnection of either Project Phase on the safety and reliability of the Transmission System owned by IID, other than IID's share of the JPP, and provides a list of facilities that are required as a result of proposed interconnection, along with an estimate of cost responsibility and time to construct. This Affected System Study may be performed, at IID's option, either serially or in a cluster.

Affected System Study Agreement shall mean an agreement between the Interconnection Customer and IID whereby IID will perform and Interconnection Customer will pay the costs of an Affected System Study. The total costs will be pro rated to the extent IID performs the Affected System Study in a cluster for multiple generators seeking to interconnect to the CAISO controlled grid, with Interconnection Customer allocated a proportionate share of the total costs.

Affiliate shall mean, with respect to a corporation, partnership or other entity, each such other corporation, partnership or other entity that directly or indirectly, through one or more intermediaries, controls, is controlled by, or is under common control with, such corporation, partnership or other entity.

Ancillary Services shall mean those services that are necessary to support the transmission of capacity and energy from resources to loads while maintaining reliable operation of the Transmission System in accordance with Good Utility Practice.

Applicable Laws and Regulations shall mean all duly promulgated applicable federal, state and local laws, regulations, rules, ordinances, codes, decrees, judgments, directives, or judicial or administrative orders, permits and other duly authorized actions of any Governmental Authority.

Applicable Reliability Council shall mean the Western Electricity Coordinating Council or its successor.

Applicable Reliability Standards shall mean the requirements and guidelines of NERC, the Applicable Reliability Council, and the applicable Balancing Authority.

Balancing Authority shall mean the responsible entity that integrates resource plans ahead of time, maintains load-interchange-generation balance within a Balancing Authority Area, and supports interconnection frequency in real time.

Balancing Authority Area shall mean the collection of generation, transmission, and loads within the metered boundaries of the Balancing Authority. The Balancing Authority maintains load resource balance within this area.

Base Case shall mean the base case power flow, short circuit, and stability data bases used for the Interconnection Studies by APS, the CAISO and its designees, or Interconnection Customer.

Breach shall mean the failure of a Party to perform or observe any material term or condition of this Agreement.

Breaching Party shall mean a Party that is in Breach of this Agreement.

Business Day shall mean Monday through Friday, excluding Federal Holidays and the day after Thanksgiving Day.

Calendar Day shall mean any day including Saturday, Sunday or a Federal Holiday.

CAISO Interconnection Service shall have the meaning set forth in Article 4.1.1.

Clustering shall mean the process whereby a group of Interconnection Requests is studied together, instead of serially, for the purpose of conducting the Interconnection System Impact Study.

Commercial Operation shall mean the status of a Project Block at a Generating Facility that has commenced generating electricity for sale, excluding electricity generated during Trial Operation.

Commercial Operation Date shall mean the date on which the Interconnection Customer declares completion of all Project Blocks within a Project Phase, as described in Appendix E to this Agreement and in accordance with the implementation plan agreed to by the Parties for multiple Project Blocks at the Generating Facility.

Confidential Information shall mean any confidential, proprietary or trade secret information of a plan, specification, pattern, procedure, design, device, list, concept, policy or compilation relating to the present or planned business of a Party, which is designated as confidential by the Party supplying the information, whether conveyed orally, electronically, in writing, through inspection, or otherwise, subject to Article 22.1.2.

Default shall mean the failure of a Breaching Party to cure its Breach in accordance with Article 17 of this Agreement.

Dispute Resolution shall mean the procedure for resolution of a dispute between the Parties in which they will first attempt to resolve the dispute on an informal basis.

Distribution System shall mean each of the respective facilities and equipment of APS, IID or SDG&E used to transmit electricity to ultimate usage points such as homes and industries directly from nearby generators or from interchanges with higher voltage transmission networks which transport bulk power over longer distances. The voltage levels at which distribution systems operate differ among areas.

Distribution Upgrades shall mean the additions, modifications, and upgrades to the Distribution System at or beyond the Point of Interconnection to facilitate interconnection of the Generating Facility and render the transmission service necessary to effect Interconnection Customer's wholesale sale of electricity in interstate commerce. Distribution Upgrades do not include Interconnection Facilities.

Effective Date shall mean the date on which this Agreement becomes effective upon execution by the Parties subject to acceptance by FERC, or if filed unexecuted pursuant to Section 205 of the Federal Power Act, upon the date specified by FERC, for those Parties which are FERC-jurisdictional public utilities; provided, however, that, as applied to IID, the Effective Date of this Agreement shall not commence until the Agreement is actually executed by IID, either voluntarily or pursuant to a lawful order issued by FERC in accordance with Sections 210 and 212 of the Federal Power Act.

Emergency Condition shall mean a condition or situation: (1) that in the judgment of the Party making the claim is imminently likely to endanger life or property; or (2) that, in the case of a Transmission Owner or the CAISO, is imminently likely (as determined in a non-discriminatory manner) to cause a material adverse effect on the security of, or damage to its Transmission System, its Interconnection Facilities or the electric systems of others to which its Transmission System is directly connected; or (3) that, in the case of Interconnection Customer, is imminently likely (as determined in a non-discriminatory manner) to cause a material adverse effect on the security of, or damage to, the Generating Facility or Interconnection Customer's Interconnection Facilities. System restoration and black start shall be considered Emergency Conditions; provided, that Interconnection Customer is not obligated by this Agreement to possess black start capability.

Energy Resource Interconnection Service shall mean an Interconnection Service that allows the Interconnection Customer to connect its Generating Facility to the APS Transmission System and IID's share of the JPP to be eligible to deliver the Generating Facility's electric output using the existing firm or nonfirm capacity of the APS Transmission System and IID's share of the JPP on an as available basis. Energy Resource Interconnection Service in and of itself does not convey transmission service.

Engineering & Procurement (E&P) Agreement shall mean an agreement between NextLight and APS, on behalf of the Transmission Owners pursuant to the Participation Agreement, to begin engineering and procurement of long lead-time items necessary for the establishment of the interconnection in order to advance the implementation of the Interconnection Requests for Phase A of the Interconnection Project, which has been duly assigned to Agua Caliente Solar, LLC.

Environmental Law shall mean Applicable Laws or Regulations relating to pollution or protection of the environment or natural resources.

Federal Power Act shall mean the Federal Power Act, as amended, 16 U.S.C. §§ 791a et seq.

FERC shall mean the Federal Energy Regulatory Commission or its successor.

Force Majeure shall mean any act of God, labor disturbance, act of the public enemy, war, insurrection, riot, fire, storm or flood, earthquake, explosion, breakage or accident to machinery or equipment, any order, regulation or restriction imposed by governmental, military or lawfully established civilian authorities, or any other cause beyond a Party's control. A Force Majeure event does not include acts of negligence or intentional wrongdoing by the Party claiming Force Majeure.

Generating Facility shall mean Interconnection Customer's device for the production of electricity identified in the Interconnection Request(s), but shall not include the Interconnection Customer's Interconnection Facilities. The Generating Facility consists of Phase A of the Generating Facility and Phase B of the Generating Facility.

Generating Facility Capacity shall mean the net capacity of the Generating Facility and the aggregate net capacity of the Generating Facility where it includes multiple energy production devices.

Good Utility Practice shall mean any of the practices, methods and acts engaged in or approved by a significant portion of the electric utility industry during the relevant time period, or any of the practices, methods and acts which, in the exercise of reasonable judgment in light of the facts known at the time the decision was made, could have been expected to accomplish the desired result at a reasonable cost consistent with good business practices, reliability, safety and expedition. Good Utility Practice is not intended to be any one of a number of the optimum practices, methods, or acts to the exclusion of all others, but rather to be acceptable practices, methods, or acts generally accepted in the region.

Governmental Authority shall mean any federal, state, local or other governmental regulatory or administrative agency, court, commission, department, board, or other governmental subdivision, legislature, rulemaking board, tribunal, or other governmental authority having jurisdiction over the Parties, their respective facilities, or the respective services they provide, and exercising or entitled to exercise any administrative, executive, police, or taxing authority or power; provided, however, that such term does not include Interconnection Customer, Transmission Owners, the CAISO, or any Affiliate thereof.

Hazardous Substances shall mean any chemicals, materials or substances defined as or included in the definition of "hazardous substances," "hazardous wastes," "hazardous materials," "hazardous constituents," "restricted hazardous materials," "extremely hazardous substances," "toxic substances," "radioactive substances," "contaminants," "pollutants," "toxic pollutants" or words of similar meaning and regulatory effect under any applicable Environmental Law, or any other chemical, material or substance, exposure to which is prohibited, limited or regulated by any applicable Environmental Law.

Initial Synchronization Date shall mean the date upon which the first Project Block of a Project Phase is initially synchronized and upon which Trial Operation begins.

In-Service Date shall mean the date upon which the Interconnection Customer reasonably expects it will be ready to begin use of the Transmission Owners' Interconnection Facilities to obtain back feed power.

Interconnection Customer shall mean Agua Caliente Solar LLC, to which NextLight has duly assigned its Interconnection Requests for Phase A of the Generating Facility, and North Gila River Development, LLC, to which NextLight has duly assigned its Interconnection Request submitted only to APS for Phase B of the Generating Facility, and their successors and assigns.

Interconnection Customer's Interconnection Facilities shall mean all facilities and equipment, as identified in Appendices A-1 and A-2 of this Agreement, that are located between the Generating Facility and the Point of Change of Ownership, including any modification, addition, or upgrades to such facilities and equipment necessary to physically and electrically interconnect the Generating Facility to the JPP. Interconnection Customer's Interconnection Facilities are sole use facilities.

Interconnection Facilities shall mean the Transmission Owners' Interconnection Facilities and the Interconnection Customer's Interconnection Facilities. Collectively, Interconnection Facilities include all facilities and equipment between the Generating Facility and the Point of Interconnection, including any modification, additions or upgrades that are necessary to physically and electrically interconnect the Generating Facility to the JPP. Interconnection Facilities are sole use facilities and shall not include Distribution Upgrades, Stand Alone Network Upgrades or Network Upgrades.

Interconnection Facilities Study shall mean a study conducted by APS or a third party consultant for the Interconnection Customer to determine a list of facilities (including Transmission Owners' Interconnection Facilities and Network Upgrades to the JPP as identified in the Interconnection System Impact Study), the cost of those facilities, and the time required to interconnect the Generating Facility with the JPP; the scope of the study is defined in Section 8 of the APS Large Generator Interconnection Procedures.

Interconnection Feasibility Study shall mean a preliminary evaluation of the system impact and cost of interconnecting the Generating Facility to the JPP, the scope of which is described in Section 6 of the APS Large Generator Interconnection Procedures.

Interconnection Financial Security shall have the meaning assigned to it in Section 1.2 of the CAISO's Large Generator Interconnection Procedures.

Interconnection Request shall mean a request, in the form of Appendix 1 to the Large Generator Interconnection Procedures, in accordance with the APS or CAISO Tariffs, to interconnect a new Generating Facility, or to increase the capacity of, or make a Material Modification to the operating characteristics of, an existing Generating Facility that is interconnected with the JPP. The Interconnection Customer made an Interconnection Request to APS for both Phase A of the Generating Facility and Phase B of the Generating Facility and an Interconnection Request to the CAISO only for Phase A of the Generating Facility. The Interconnection Customer did not make an Interconnection Request to IID.

Interconnection Service shall mean the service provided by the Transmission Owners and the CAISO associated with interconnecting the Interconnection Customer's Generating Facility to the JPP and enabling them to receive electric energy and capacity from the Generating Facility at the Point of Interconnection, pursuant to the terms of this Agreement and the Tariffs of APS, IID, SDG&E, and the CAISO.

Interconnection Study shall mean any of the following studies: (1) the Interconnection Feasibility Study, the Interconnection System Impact Study, or the Interconnection Facilities Study described in the APS Large Generator Interconnection Procedures; or (2) the Phase I Interconnection Study or the Phase II Interconnection Study described in the CAISO Large Generator Interconnection Procedures.

Interconnection System Impact Study shall mean an engineering study that evaluates the impact of the proposed interconnection on the safety and reliability of Transmission Owners' Transmission Systems and, if applicable, an Affected System. The study shall identify and detail the system impacts that would result if the Generating Facility were interconnected without project modifications or system modifications, focusing on the Adverse System Impacts identified in the Interconnection Feasibility Study, or to study potential impacts, including but not limited to those identified in the Scoping Meeting as described in the APS Large Generator Interconnection Procedures.

Interconnection System Impact Study Agreement shall mean the form of agreement contained in the Large Generator Interconnection Procedures of APS for conducting an Interconnection System Impact Study.

IRS shall mean the Internal Revenue Service.

Joint Operating Committee shall be a group made up of representatives from Interconnection Customer and APS, on behalf of the Transmission Owners, to coordinate operating and technical considerations of Interconnection Service.

Joint Participation Project (JPP) shall mean the transmission facilities jointly owned by APS, IID and SDG&E pursuant to the Arizona Transmission System Participation Agreement, as amended.

Large Generating Facility shall mean a Generating Facility having a Generating Facility Capacity of more than 20 MW.

Large Generator Interconnection Procedures (LGIP) shall mean the interconnection procedures applicable to an Interconnection Request pertaining to a Large Generating Facility that are included in the APS or the CAISO Tariff. With respect to the Interconnection Request made to the CAISO for Phase A of the Generating Facility, the applicable LGIP is the LGIP for Interconnection Requests in a Queue Cluster Window, which is found in CAISO Tariff Appendix Y.

Loss shall mean any and all damages, losses and claims, including claims and actions relating to injury to or death of any person or damage to property, demand, suits, recoveries, costs and expenses, court costs, attorney fees, and all other obligations by or to third parties.

Material Modification shall mean those modifications that have a material impact on the cost or timing of any Interconnection Request or any other valid interconnection request with a later queue priority date.

Metering Equipment shall mean all metering equipment installed or to be installed for measuring the output at the Generating Facility pursuant to this Agreement at the metering points, including but not limited to instrument transformers, MWh-meters, data acquisition equipment, transducers, remote terminal unit, communications equipment, phone lines, and fiber optics.

NERC shall mean the North American Electric Reliability Corporation or its successor organization.

Network Resource shall mean any designated generating resource owned, purchased, or leased by a Network Customer under the APS Network Integration Transmission Service Tariff, or the IID Open Access Transmission Tariff. Network Resources do not include any resource, or any portion thereof, that is committed for sale to third parties or otherwise cannot be called upon to meet the Network Customer's Network Load on a non-interruptible basis.

Network Resource Interconnection Service shall mean an Interconnection Service that allows an interconnection customer to integrate its Large Generating Facility with the APS Transmission System or IID's share of the JPP in a manner comparable to that in which APS or IID integrates its generating facilities to serve native load customers. Network Resource Interconnection Service in and of itself does not convey transmission service.

Network Upgrades shall mean the additions, modifications, and upgrades to the Transmission Owners' and CAISO's Transmission Systems required at or beyond the point at which the Interconnection Facilities connect to the JPP to accommodate the interconnection of the Large Generating Facility to the Transmission Owners' and the CAISO's Transmission Systems.

Notice of Dispute shall mean a written notice of a dispute or claim that arises out of or in connection with this Agreement or its performance.

Operating Agent of the JPP shall mean APS as the entity designated as the operating agent of the JPP pursuant to the Participation Agreement.

Ownership Interests shall mean the ownership interests of APS, IID and SDG&E in the JPP, as set forth in the Participation Agreement, as amended, and for purposes of this Agreement, APS, 11 percent; IID, 12.78 percent; and SDG&E, 76.22 percent.

Party or Parties shall mean Transmission Owner(s), the CAISO, Interconnection Customer or the applicable combination of the above.

Phase I Interconnection Study shall have the meaning set forth in the CAISO Tariff as of the effective date of this Agreement.

Phase II Interconnection Study shall have the meaning set forth in the CAISO Tariff as of the effective date of this Agreement.

Phase A of the Generating Facility shall mean no more than 290 MW (net) of solar photovoltaic units installed at the site of the Generating Facility, as described in Appendix C.

Phase B of the Generating Facility shall mean no more than 210 MW (net) of solar photovoltaic units installed at the site of the Generating Facility, as described in Appendix C, after Phase A of the Generating Facility has been completed.

Phase A of the Interconnection Project shall mean construction of the Interconnection Facilities and Network Upgrades required to interconnect Phase A of the Generating Facility, as described in Appendix A-1.

Phase B of the Interconnection Project shall mean construction of the Interconnection Facilities and Network Upgrades required to interconnect Phase B of the Generating Facility, as described in Appendices A-2 and A-3 and as may be identified in studies provided for in Appendix C.

Point of Change of Ownership shall mean the point, as set forth in Appendices A-1 and A-2 to this Agreement, where the Interconnection Customer's Interconnection Facilities connect to the Transmission Owners' Interconnection Facilities.

Point of Interconnection shall mean the point, as set forth in Appendices A-1 and A-2 to this Agreement, where the Interconnection Facilities connect to the JPP.

Project Block shall mean a portion of the solar photovoltaic units within a Project Phase as described in Appendix B-1 and B-2.

Project Phase shall mean either Phase A of the Generating Facility or Phase B of the Generating Facility.

Queue Position shall mean the order of a valid Interconnection Request, relative to all other pending valid Interconnection Requests, that is established based upon the date and time of receipt of the valid Interconnection Request by APS or the CAISO under its Tariff.

Reasonable Efforts shall mean, with respect to an action required to be attempted or taken by a Party under this Agreement, efforts that are timely and consistent with Good Utility Practice and are otherwise substantially equivalent to those a Party would use to protect its own interests.

Scoping Meeting shall mean the meetings between representatives of the Interconnection Customer and Transmission Owners and the CAISO conducted for the purpose of discussing alternative interconnection options, to exchange information including any transmission data and earlier study evaluations that would be reasonably expected to impact such interconnection options, to analyze such information, and to determine the potential feasible Points of Interconnection.

Site Control shall mean documentation reasonably demonstrating: (1) ownership of, a leasehold interest in, or a right to develop a site for the purpose of constructing the Generating Facility; (2) an option to purchase or acquire a leasehold site for such purpose; or (3) an exclusivity or other business relationship between Interconnection Customer and the entity

having the right to sell, lease or grant Interconnection Customer the right to possess or occupy a site for such purpose.

Small Generating Facility shall mean a Generating Facility that has a Generating Facility Capacity of no more than 20 MW.

Stand Alone Network Upgrades shall mean Network Upgrades that an Interconnection Customer may construct without affecting day-to-day operations of the Transmission System during their construction. The Transmission Owners, the CAISO and the Interconnection Customer must agree as to what constitutes Stand Alone Network Upgrades and identify them in Appendices A-1, A-2, and A-3 to this Agreement.

System Protection Facilities shall mean the equipment, including necessary protection signal communications equipment, that protects (1) the Transmission Owners' and the CAISO's Transmission Systems from faults or other electrical disturbances occurring at the Generating Facility and (2) the Generating Facility from faults or other electrical system disturbances occurring on the Transmission Owners' and the CAISO's Transmission Systems or on other delivery systems or other generating systems to which the Transmission Owners' and the CAISO's Transmission Systems are directly connected.

Tariff shall mean the APS, IID, SDG&E or CAISO tariffs through which open access transmission service and Interconnection Service are offered, as filed with FERC with respect to FERC-jurisdictional public utilities and as posted with respect to IID, and as amended or supplemented from time to time, or any successor tariff.

Transmission Owner(s) shall mean APS, IID and SDG&E, as joint owners of the JPP at the Point of Interconnection. Pursuant to the Participation Agreement, APS is Operating Agent of the JPP and acts on behalf of the Transmission Owners with respect to the JPP.

Transmission Owners' Interconnection Facilities shall mean all facilities and equipment owned, controlled or operated by the Transmission Owners from the Point of Change of Ownership identified in Appendices A-1 and A-2 to the Point of Interconnection as identified in Appendices A-1 and A-2 to this Agreement, including any modifications, additions or upgrades to such facilities and equipment. Transmission Owners' Interconnection Facilities are sole use facilities and shall not include Distribution Upgrades, Stand Alone Network Upgrades or Network Upgrades.

Transmission System shall mean the facilities, including the portion of the JPP, owned, controlled or operated by Transmission Owner or the CAISO that are used to provide transmission service under the respective Tariff.

Trial Operation shall mean the period during which Interconnection Customer is engaged in on-site test operations and commissioning of the first Project Block of each Project Phase prior to Commercial Operation.

Article 2. Effective Date, Term, and Termination

2.1 Effective Date. Except as provided below with respect to IID, this Agreement shall become effective upon execution by the Parties and acceptance for filing by FERC, or if filed unexecuted under Section 205 of the Federal Power Act, upon the date specified by

FERC for the Transmission Owners that are FERC-jurisdictional public utilities and the CAISO. Such Transmission Owners and the CAISO shall promptly submit this Agreement for filing with FERC upon execution in accordance with Article 3.1. The Parties acknowledge that IID is not a public utility subject to FERC's jurisdiction under Section 205 or 206 of the Federal Power Act. Therefore, as applied to IID, the Effective Date for the Agreement shall not commence until the later of the date the Agreement is executed by IID, either voluntarily or pursuant to a lawful order issued by FERC in accordance with Sections 210 and 212 of the Federal Power Act, and the date the Agreement is accepted for filing with regard to the Transmission Owners that are FERC-jurisdictional and the CAISO.

2.2 Term of Agreement. Subject to the provisions of Article 2.3, this Agreement shall remain in effect for a period of forty (40) years from the Effective Date and shall be automatically renewed for each successive one-year period thereafter.

2.3 Termination Procedures.

2.3.1 Written Notice. This Agreement may be terminated by (i) Interconnection Customer after giving all other Parties ninety (90) Calendar Days advance written notice, or (ii) by APS, on behalf of the Transmission Owners, or the CAISO notifying FERC after the Generating Facility permanently ceases Commercial Operation. Notice of termination by the Interconnection Customer must be provided by both of the entities comprising the Interconnection Customer.

2.3.2 Default. A Party may terminate this Agreement in accordance with Article 17.

2.3.3 Notwithstanding Articles 2.3.1 and 2.3.2, no termination shall become effective until the Parties have complied with all Applicable Laws and Regulations applicable to such termination, including any required filing with FERC of a notice of termination of this Agreement, which notice has been accepted for filing by FERC. For clarity and avoidance of ambiguity, IID is not a jurisdictional public utility required to file a notice of termination under Section 205 or 206 of the Federal Power Act prior to terminating its participation in this Agreement in accordance with the terms of such Agreement.

2.4 Termination Costs

Upon receipt of a notice of the termination of this Agreement pursuant to Article 2.3 above, the Transmission Owners and the CAISO will promptly determine the total cost responsibility of the Interconnection Customer. If, as of the date of receipt of such notice of termination, the Interconnection Customer has not already paid its share of Network Upgrade costs, including those set forth in Appendices A-1, A-2, and A-3, APS, as the Operating Agent of the JPP, will enforce the financial security rights of APS and IID pursuant to this Agreement and SDG&E will cause Interconnection Customer's Interconnection Financial Security associated with its cost responsibility for SDG&E's non-JPP Network Upgrades and SDG&E's share of the JPP Network Upgrades set forth in Appendices A-1, A-2, and A-3 to be liquidated, in accordance with Section 9.4 of the CAISO's Large Generator Interconnection Procedures.

The Interconnection Customer will also be responsible for all costs incurred or irrevocably committed to be incurred in association with the construction of the Transmission Owners' Interconnection Facilities (including any cancellation costs relating to orders or contracts for Interconnection Facilities and equipment) and other such expenses for which the Transmission Owners or the CAISO have incurred expenses or have irrevocably committed to incur expenses and have not been reimbursed by the Interconnection Customer, as of the date of receipt of the notice of termination, subject to the limitations set forth in this Article 2.4. Nothing in this Article 2.4 shall limit the Parties' rights under Article 17. If, as of the date of the receipt of the notice of termination, the Interconnection Customer has not already reimbursed the Transmission Owners and the CAISO for costs incurred to construct the Transmission Owners' Interconnection Facilities, APS, as Operating Agent of the JPP, shall enforce the financial security rights of APS and IID pursuant to this Agreement and SDG&E will liquidate the Interconnection Customer's Interconnection Financial Security associated with the construction of SDG&E's share of the Transmission Owners' Interconnection Facilities, in accordance with Section 9.4 of the CAISO Large Generator Interconnection Procedures.

For cost responsibility for Interconnection Facilities and Network Upgrades to the JPP set forth in Appendices A-1 and A-2, the Transmission Owners' financial security rights shall be enforced in accordance with the provisions for enforcement of financial security set forth in Appendices A-1 and A-2.

If the amount of the financial security, including the Interconnection Financial Security, liquidated by Transmission Owners under this Article 2.4 is insufficient to compensate Transmission Owners and the CAISO for actual costs associated with the construction of the Transmission Owners' Interconnection Facilities and Network Upgrades contemplated in this Article, any additional amounts will be the responsibility of the Interconnection Customer. Any such additional amounts due from the Interconnection Customer beyond the amounts covered by its financial security, including its Interconnection Financial Security, will be due to the Transmission Owners immediately upon termination of this Agreement, subject, with respect to amounts due SDG&E, to the provisions of Section 9.4 of the CAISO Large Generator Interconnection Procedures.

If the amount of the Interconnection Financial Security exceeds the Interconnection Customer's cost responsibility under Section 9.4 of the CAISO's Large Generator Interconnection Procedures, such excess amount will be released to the Interconnection Customer by SDG&E in accordance with Section 9.4 of the CAISO's Large Generator Interconnection Procedures.

Notwithstanding the foregoing, in the event of termination of this Agreement, the Parties shall use commercially Reasonable Efforts to mitigate the costs, damages and charges arising as a consequence of termination. Upon termination of this Agreement, unless otherwise ordered or approved by FERC to the extent FERC possesses jurisdiction over the public utilities which are Parties to this Agreement:

2.4.1 With respect to any portion of Transmission Owners' Interconnection Facilities that have not yet been constructed or installed, Transmission Owners shall to the extent possible and with Interconnection Customer's authorization cancel any pending orders of, or return, any materials or equipment for, or contracts for

construction of, such Interconnection Facilities; provided that in the event Interconnection Customer elects not to authorize such cancellation, Interconnection Customer shall assume all payment obligations with respect to such materials, equipment, and contracts, and Transmission Owners shall deliver such material and equipment, and, if necessary, assign such contracts, to Interconnection Customer as soon as practicable, at Interconnection Customer's expense. To the extent that Interconnection Customer has already paid Transmission Owners for any or all such costs of materials or equipment not taken by Interconnection Customer, Transmission Owners shall promptly refund such amounts to Interconnection Customer, less any costs, including penalties incurred by Transmission Owners to cancel any pending orders of or return such materials, equipment, or contracts.

- 2.4.2** Transmission Owners may, at their collective option, retain any portion of such materials, equipment, or facilities that Interconnection Customer chooses not to accept delivery of, in which case Transmission Owners shall be responsible for all costs associated with procuring such materials, equipment, or facilities.
- 2.4.3** With respect to any portion of the Interconnection Facilities, and any other facilities already installed or constructed pursuant to the terms of this Agreement, Interconnection Customer shall be responsible for all costs associated with the removal, relocation or other disposition or retirement of such materials, equipment, or facilities.

- 2.5** **Disconnection.** Upon termination of this Agreement as to Phase A of the Interconnection Project, APS, on behalf of Transmission Owners, will take all appropriate steps to disconnect Phase A of the Interconnection Project from the JPP. All costs required to effectuate such disconnection shall be borne by the terminating Party, unless such termination resulted from the non-terminating Party's Default of this Agreement or such non-terminating Party otherwise is responsible for these costs under this Agreement.

Upon termination of this Agreement as to Phase B of the Interconnection Project, APS, on behalf of Transmission Owners will take all appropriate steps to disconnect Phase B of the Interconnection Project from the JPP. All costs required to effectuate such disconnection shall be borne by the terminating Party, unless such termination resulted from the non-terminating Party's Default of this Agreement or such non-terminating Party otherwise is responsible for these costs under this Agreement.

- 2.6** **Survival.** This Agreement shall continue in effect after termination to the extent necessary to provide for final billings and payments and for costs incurred hereunder, including billings and payments pursuant to this Agreement; to permit the determination and enforcement of liability and indemnification obligations arising from acts or events that occurred while this Agreement was in effect; and to permit the Parties to have access to the lands of another Party pursuant to this Agreement or other applicable agreements, to disconnect, remove or salvage its own facilities and equipment.

Article 3. Regulatory Filings

- 3.1 Filing.** The CAISO and Transmission Owners that are FERC-jurisdictional public utilities shall file this Agreement (and any amendment hereto) with the appropriate Governmental Authority, if required. Interconnection Customer may request that any information so provided be subject to the confidentiality provisions of Article 22. If Interconnection Customer has executed this Agreement, or any amendment thereto, Interconnection Customer shall reasonably cooperate with Transmission Owners and the CAISO with respect to such filing and to provide any information reasonably requested by Transmission Owners and the CAISO needed to comply with applicable regulatory requirements. For clarity and avoidance of ambiguity, IID is not a jurisdictional public utility subject to a filing requirement under Section 205 of the Federal Power Act.

Article 4. Scope of Service

- 4.1 Interconnection Product Options.** Interconnection Customer has selected Energy Resource Interconnection Service from APS to interconnect to the APS Transmission System and IID's share of the JPP, and Interconnection Service from the CAISO.

- 4.1.1 CAISO Interconnection Service.** Interconnection Service provided by the CAISO and SDG&E allows the Interconnection Customer to connect the Large Generating Facility to the CAISO's Transmission System and be eligible to deliver the Large Generating Facility's output using the available capacity of the CAISO's Transmission System pursuant to the CAISO Tariff.

Interconnection Service does not necessarily provide the Interconnection Customer with the capability to physically deliver the output of its Large Generating Facility to any particular load on the CAISO Transmission System without incurring congestion costs. In the event of transmission constraints on the CAISO Transmission System, the Interconnection Customer's Large Generating Facility shall be subject to the applicable congestion management procedures in the CAISO Tariff in the same manner as all other resources.

- 4.1.2 Energy Resource Interconnection Service.**

4.1.2.1 The Product. Energy Resource Interconnection Service from APS and IID allows Interconnection Customer to connect the Large Generating Facility to the JPP and be eligible to deliver the Large Generating Facility's output using available capacity on the existing firm or non-firm capacity of the APS Transmission System and IID's share of the JPP on an "as available" basis.

4.1.2.2 Transmission Delivery Service Implications. Under Energy Resource Interconnection Service, Interconnection Customer will be eligible to inject power from the Large Generating Facility into and deliver power across the APS Transmission System and IID's share of the JPP on an "as available" basis up to the amount of MWs identified in the applicable stability and steady state studies to the extent the upgrades initially required to qualify for Energy Resource Interconnection Service have been constructed. No transmission delivery service from the Large Generating Facility is assured, but Interconnection Customer may obtain Point-to-Point Transmission Service, Network Integration Transmission

Service, or be used for secondary network transmission service, pursuant to the APS Tariff or Transmission Service on IID's share of the JPP pursuant to the IID Tariff, up to the maximum output identified in the stability and steady state studies. In order for Interconnection Customer to obtain the right to deliver or inject energy beyond the Large Generating Facility Point of Interconnection or to improve its ability to do so, transmission delivery service must be obtained pursuant to the provisions of the APS or IID Tariffs. The Interconnection Customer's ability to inject its Large Generating Facility output beyond the Point of Interconnection, therefore, will depend on the existing capacity of the APS or IID Transmission Systems at such time as a transmission service request is made that would accommodate such delivery. The provision of firm Point-to-Point Transmission Service or Network Integration Transmission Service may require the construction of additional Network Upgrades.

4.1.3 Network Resource Interconnection Service.

4.1.3.1 The Product. [THIS SECTION IS NOT APPLICABLE TO THIS AGREEMENT.]

4.1.3.2 Transmission Delivery Service Implications. [THIS SECTION IS NOT APPLICABLE TO THIS AGREEMENT.]

4.2 Provision of Service. APS, on behalf of the Transmission Owners, and the CAISO shall provide Interconnection Service for the Large Generating Facility at the Point of Interconnection.

4.3 Performance Standards. Each Party shall perform all of its obligations under this Agreement in accordance with Applicable Laws and Regulations, Applicable Reliability Standards, and Good Utility Practice, and to the extent a Party is required or prevented or limited in taking any action by such regulations and standards, such Party shall not be deemed to be in Breach of this Agreement for its compliance therewith. If such Party is a Transmission Owner or the CAISO, then that Party shall negotiate an amendment to the Agreement and, if it is a FERC-jurisdictional public utility, shall submit the amendment to FERC for approval. For clarity and avoidance of ambiguity, IID is not a FERC-jurisdictional public utility subject to a filing requirement under Section 205 of the Federal Power Act.

4.4 No Transmission Delivery Service. The execution of this Agreement does not constitute a request for, nor the provision of, any transmission delivery service under any applicable Tariff, and does not convey any right to deliver electricity to any specific customer or point of delivery.

4.5 Interconnection Customer Provided Services. The services provided by Interconnection Customer under this Agreement are set forth in Article 9.6 and Article 13.5.1. Interconnection Customer shall be paid for such services in accordance with Article 11.6.

Article 5. Interconnection Facilities Engineering, Procurement, and Construction

5.1 Options. Unless otherwise mutually agreed to between the Parties, Interconnection Customer shall select the In-Service Date, Initial Synchronization Date, and Commercial Operation Date; and either Standard Option or Alternate Option set forth below for completion of Transmission Owners' Interconnection Facilities and Network Upgrades as set forth in Appendices A-1, A-2, and A-3, and such dates and selected option shall be set forth in Appendices B-1, B-2, and B-3 Milestones.

5.1.1 Standard Option. APS, on behalf of Transmission Owners shall design, procure, and construct Transmission Owners' Interconnection Facilities and JPP Network Upgrades set forth in Appendices A-1 and A-2, and SDG&E shall design, procure, and construct Network Upgrades set forth in Appendix A-3, in each case using Reasonable Efforts to complete the Transmission Owners' Interconnection Facilities and these Network Upgrades by the dates set forth in Appendices B-1, B-2, and B-3 Milestones. Transmission Owners shall not be required to undertake any action which is inconsistent with their standard safety practices, material and equipment specifications, design criteria and construction procedures, labor agreements, and Applicable Laws and Regulations. In the event APS, on behalf of Transmission Owners, and/or SDG&E, as applicable, reasonably expect that they will not be able to complete Transmission Owners' Interconnection Facilities and Network Upgrades set forth in Appendices A-1, A-2, and A-3 by the specified dates in the Appendices B-1, B-2, and B-3 Milestones, APS, on behalf of Transmission Owners, and/or SDG&E, as applicable, shall promptly provide written notice to Interconnection Customer and shall undertake Reasonable Efforts to meet the earliest dates thereafter.

5.1.2 Alternate Option. [THIS SECTION IS NOT APPLICABLE TO THIS AGREEMENT.]

5.1.3 Option to Build. [THIS SECTION IS NOT APPLICABLE TO THIS AGREEMENT.]

5.1.4 Negotiated Option. [THIS SECTION IS NOT APPLICABLE TO THIS AGREEMENT.]

5.2 General Conditions Applicable to Option to Build. [THIS SECTION IS NOT APPLICABLE TO THIS AGREEMENT.]

5.3 Liquidated Damages. [THIS SECTION IS NOT APPLICABLE TO THIS AGREEMENT.]

5.4 Power System Stabilizers. If the Applicable Reliability Standards, or the guidelines and procedures established by the Applicable Reliability Council, deem a Power System Stabilizer applicable to the type of solar photovoltaic equipment used in the Generating Facility, then the Interconnection Customer shall procure, install, maintain and operate Power System Stabilizers. APS reserves the right to reasonably establish minimum acceptable settings for any installed Power System Stabilizers, subject to the design and operating limitations of the Large Generating Facility. If the Large Generating Facility's Power System Stabilizers are removed from service or not capable of automatic operation, Interconnection Customer shall immediately notify APS and restore the Power

System Stabilizers to operation as soon as possible. APS shall have the right to order the reduction in output or disconnection of the Large Generating Facility if the reliability of the Transmission System would be adversely affected as a result of improperly tuned Power System Stabilizers. The Generating Facility is a solar photovoltaic generator and as such does not have the physical characteristic to which a Power System Stabilizer would apply.

- 5.5 Equipment Procurement.** The Transmission Owners' design of Transmission Owners' Interconnection Facilities and Network Upgrades to the JPP for Phase A of the Interconnection Project, as set forth in Appendix A-1, and partial procurement of certain long-lead equipment for Phase A of the Interconnection Project has been advanced in accordance with the terms of the E & P Agreement dated March 30, 2010. To the extent the design and long lead time procurement work has not been completed pursuant to the E&P Agreement, APS, on behalf of Transmission Owners, shall finish design of Transmission Owners' Interconnection Facilities and Network Upgrades to the JPP and procure necessary equipment pursuant to the terms of this Agreement.
- 5.6 Construction Commencement.** APS, on behalf of Transmission Owners, shall commence construction of Transmission Owners' Interconnection Facilities and Network Upgrades to the JPP for which it is responsible as set forth in Appendices A-1, and A-2, and SDG&E shall commence construction of Network Upgrades to its non-JPP facilities for which it is responsible as set forth in Appendix A-3, as soon as practicable after the following additional conditions are satisfied:
- 5.6.1** Approval of the appropriate Governmental Authority has been obtained for any facilities requiring regulatory approval;
 - 5.6.2** Necessary real property rights and rights-of-way have been obtained, to the extent required for the construction of a discrete aspect of Transmission Owners' Interconnection Facilities and Network Upgrades set forth in Appendices A-1, A-2, and A-3;
 - 5.6.3** Transmission Owners have received written authorization to proceed with construction from Interconnection Customer by the date specified in Appendices B-1, B-2, and B-3 Milestones; and
 - 5.6.4** Interconnection Customer has provided payment and security in accordance with Article 11.5 by the dates specified in Appendices B-1, B-2, and B-3, Milestones.
 - 5.6.5** For Phase B of the Interconnection Project only, the conditions specified in Appendix C also shall be met before construction of Transmission Owners' Interconnection Facilities and Network Upgrades commences for that Project Phase.
- 5.7 Work Progress.** The Parties will keep each other advised periodically as to the progress of their respective design, procurement and construction efforts. Any Party may, at any time, request a progress report from another Party. If, at any time, Interconnection Customer determines that the completion of Transmission Owners' Interconnection Facilities will not be required until after the specified In-Service Date, Interconnection Customer will provide written notice to APS, SDG&E, IID, and the CAISO of such later

date upon which the completion of Transmission Owners' Interconnection Facilities will be required.

- 5.8 Information Exchange.** As soon as reasonably practicable after the Effective Date, Transmission Owners, CAISO and the Interconnection Customer shall exchange information regarding the design and compatibility of the Parties' Interconnection Facilities and compatibility of the Interconnection Facilities with Transmission Owners' and the CAISO's Transmission Systems, and shall work diligently and in good faith to make any necessary design changes.
- 5.9 Limited Operation.** If any of Transmission Owners' Interconnection Facilities or Network Upgrades are not reasonably expected to be completed prior to the Commercial Operation Date of a Project Phase, Transmission Owners and CAISO shall, upon the request and at the expense of Interconnection Customer, perform operating studies on a timely basis to determine the extent to which the Large Generating Facility and Interconnection Customer's Interconnection Facilities may operate prior to the completion of Transmission Owners' Interconnection Facilities or Network Upgrades consistent with Applicable Laws and Regulations, Applicable Reliability Standards, Good Utility Practice, and this Agreement. Transmission Owners and CAISO shall permit Interconnection Customer to operate the Project Phase and Interconnection Customer's Interconnection Facilities in accordance with the results of such studies.
- 5.10 Interconnection Customer's Interconnection Facilities ('ICIF').** Interconnection Customer shall, at its expense, design, procure, construct, own and install the ICIF, as set forth in Appendices A-1 and A-2.
- 5.10.1 Interconnection Customer's Interconnection Facility Specifications.** Interconnection Customer shall submit initial specifications for the ICIF and a Project Phase, including System Protection Facilities, to (i) APS, on behalf of Transmission Owners, and (ii) CAISO at least one hundred eighty (180) Calendar Days prior to the Initial Synchronization Date for the Project Phase; and final specifications for review and comment at least ninety (90) Calendar Days prior to the Initial Synchronization Date for the Project Phase. Transmission Owners and CAISO shall review such specifications to ensure that the ICIF and Project Phase of Large Generating Facility are compatible with the technical specifications, operational control, and safety requirements of Transmission Owners and CAISO and comment on such specifications within thirty (30) Calendar Days of Interconnection Customer's submission. All specifications provided hereunder shall be deemed confidential.
- 5.10.2 Review by Transmission Owners and CAISO.** Transmission Owners and CAISO review of Interconnection Customer's final specifications shall not be construed as confirming, endorsing, or providing a warranty as to the design, fitness, safety, durability or reliability of the Large Generating Facility, or the ICIF. Interconnection Customer shall make such changes to the ICIF as may reasonably be required by Transmission Owners or CAISO, in accordance with Good Utility Practice, to ensure that the ICIF are compatible with the technical specifications, operational control, and safety requirements of Transmission Owners and CAISO.

5.10.3 ICIF Construction. The ICIF shall be designed and constructed in accordance with Good Utility Practice. Within one hundred twenty (120) Calendar Days after the Commercial Operation Date of a Project Phase, unless the Parties agree on another mutually acceptable deadline, Interconnection Customer shall deliver to (i) APS, on behalf of Transmission Owners, and (ii) CAISO “as-built” drawings, information and documents for the ICIF and the applicable Project Phase of the Large Generating Facility, such as: a one-line diagram, a site plan showing the Large Generating Facility and the ICIF, plan and elevation drawings showing the layout of the ICIF, a relay functional diagram, relaying AC and DC schematic wiring diagrams and relay settings for all facilities associated with Interconnection Customer’s step-up transformers, the facilities connecting the Project Phase to the step-up transformers and the ICIF, and the impedances (determined by factory tests) for the associated step-up transformers and the Project Phase. The Interconnection Customer shall provide (i) APS, on behalf of Transmission Owners, and (ii) CAISO specifications for the excitation system, automatic voltage regulator, Large Generating Facility control and protection settings, transformer tap settings, and communications, if applicable. Any deviations from the relay settings, machine specifications, and other specifications originally submitted by the Interconnection Customer shall be assessed by the Transmission Owners and the CAISO pursuant to the appropriate provisions of this Agreement and the APS and CAISO Large Generator Interconnection Procedures.

5.11 Transmission Owners’ Interconnection Facilities Construction. Transmission Owners’ Interconnection Facilities shall be designed and constructed in accordance with Good Utility Practice. Upon request, within one hundred twenty (120) Calendar Days after the Commercial Operation Date, unless the Parties agree on another mutually acceptable deadline, APS, on behalf of Transmission Owners, shall deliver to Interconnection Customer and the CAISO the “as-built” drawings, information and documents for Transmission Owners’ Interconnection Facilities, including appropriate drawings and relay diagrams.

APS, on behalf of Transmission Owners, will obtain control of Transmission Owners’ Interconnection Facilities and Stand Alone Network Upgrades to the JPP upon completion of such facilities.

5.12 Access Rights. Upon reasonable notice and supervision by a Party, and subject to any required or necessary regulatory approvals, a Party (“Granting Party”) shall furnish at no cost to the other Party (“Access Party”) any rights of use, licenses, rights of way and easements with respect to lands owned or controlled by the Granting Party, its agents (if allowed under the applicable agency agreement), or any Affiliate, that are necessary to enable the Access Party to obtain ingress and egress to construct, operate, maintain, repair, test (or witness testing), inspect, replace or remove facilities and equipment to: (i) interconnect the Large Generating Facility with the JPP; (ii) operate and maintain the Large Generating Facility, the Interconnection Facilities and the JPP; and (iii) disconnect or remove the Access Party’s facilities and equipment upon termination of this Agreement. In exercising such licenses, rights of way and easements, the Access Party shall not unreasonably disrupt or interfere with normal operation of the Granting Party’s business and shall adhere to the safety rules and procedures established in advance, as

may be changed from time to time, by the Granting Party and provided to the Access Party.

- 5.13 Lands of Other Property Owners.** If any part of Transmission Owners' Interconnection Facilities and/or Network Upgrades is to be installed on property owned by persons other than Interconnection Customer or Transmission Owners, Transmission Owners shall at Interconnection Customer's expense use efforts, similar in nature and extent to those that they typically undertake on their own behalf or on behalf of their Affiliates, including use of eminent domain authority, and to the extent consistent with state law, to procure from such persons any rights of use, licenses, rights of way and easements that are necessary to construct, operate, maintain, test, inspect, replace or remove Transmission Owners' Interconnection Facilities and/or Network Upgrades upon such property.
- 5.14 Permits.** Transmission Owners and Interconnection Customer shall cooperate with each other in good faith in obtaining all permits, licenses, and authorizations that are necessary to accomplish the interconnection in compliance with Applicable Laws and Regulations. With respect to this paragraph, Transmission Owners shall provide permitting assistance to Interconnection Customer comparable to that provided to Transmission Owners' own, or an Affiliate's generation.
- 5.15 Early Construction of Base Case Facilities.** Interconnection Customer may request Transmission Owners to construct, and Transmission Owners shall construct, using Reasonable Efforts to accommodate Interconnection Customer's In-Service Date, all or any portion of any Network Upgrades required for Interconnection Customer to be interconnected to the JPP which are included in the Base Case of the Interconnection Facilities Study for Interconnection Customer, and which also are required to be constructed for another interconnection customer, but where such construction is not scheduled to be completed in time to achieve Interconnection Customer's In-Service Date.
- 5.16 Suspension.** Interconnection Customer reserves the right, upon written notice to APS, SDG&E, IID and the CAISO, to suspend at any time all work by APS and SDG&E associated with the construction and installation of Transmission Owners' Interconnection Facilities and/or Network Upgrades required under this Agreement, other than Network Upgrades, if any, identified in the Phase II Interconnection Study under the CAISO's Large Generator Interconnection Procedures as common to multiple Generating Facilities, with the condition that the Transmission System shall be left in a safe and reliable condition in accordance with Good Utility Practice and Transmission Owners' safety and reliability criteria, and the Applicable Reliability Standards. In such event, Interconnection Customer shall be responsible for all reasonable and necessary costs which Transmission Owners, (i) have incurred pursuant to this Agreement prior to the suspension and (ii) incur in suspending such work, including any costs incurred to perform such work as may be necessary to ensure the safety of persons and property and the integrity of the Transmission System during such suspension and, if applicable, any costs incurred in connection with the cancellation or suspension of material, equipment and labor contracts which Transmission Owners cannot reasonably avoid; provided, however, that prior to canceling or suspending any such material, equipment or labor contract, Transmission Owners shall obtain Interconnection Customer's authorization to do so.

APS, on behalf of Transmission Owners, with respect to facilities identified on Appendices A-1 and A-2, and SDG&E with respect to facilities identified on Appendix A-3, shall invoice Interconnection Customer for such costs pursuant to Article 12 and shall use due diligence to minimize such costs. In the event Interconnection Customer suspends work required under this Agreement pursuant to this Article 5.16, and has not requested APS, on behalf of Transmission Owners, or SDG&E to recommence the work or has not itself recommenced work required under this Agreement in time to ensure that Commercial Operation of the full Generating Facility Capacity of the Large Generating Facility is no more than three (3) years from the final Commercial Operation Date identified in Appendices B-1, B-2, and B-3, this Agreement shall be deemed terminated and the Interconnection Customer's responsibility for costs of the Transmission Owners' Interconnection Facilities and Network Upgrades set forth in Appendices A-1, A-2, and A-3 will be determined in accordance with Article 2.4. The suspension shall begin on the date the suspension is requested, or the date of the written notice to APS, on behalf of Transmission Owners, for its work or SDG&E for its work, if no effective date is specified other than Network Upgrades, if any, identified in the Phase II Interconnection Study under the CAISO's Large Generator Interconnection Procedures.

5.17 Taxes.

5.17.1 Interconnection Customer Payments Not Taxable. The Parties intend that all payments or property transfers made by Interconnection Customer to Transmission Owners for the installation of Transmission Owners' Interconnection Facilities and the Network Upgrades shall be non-taxable, either as contributions to capital, or as a refundable advance, in accordance with the Internal Revenue Code and any applicable state income tax laws and shall not be taxable as contributions in aid of construction or otherwise under the Internal Revenue Code and any applicable state income tax laws.

5.17.2 Representations and Covenants. In accordance with IRS Notice 2001-82 and IRS Notice 88-129, Interconnection Customer represents and covenants that (i) ownership of the electricity generated at the Large Generating Facility will pass to another party prior to the transmission of the electricity on a Transmission System, (ii) for income tax purposes, the amount of any payments and the cost of any property transferred to Transmission Owners for Transmission Owners' Interconnection Facilities will be capitalized by Interconnection Customer as an intangible asset and recovered using the straight-line method over a useful life of twenty (20) years, and (iii) any portion of Transmission Owners' Interconnection Facilities that is a "dual-use intertie," within the meaning of IRS Notice 88-129, is reasonably expected to carry only a de minimis amount of electricity in the direction of the Large Generating Facility. For this purpose, "de minimis amount" means no more than 5 percent of the total power flows in both directions, calculated in accordance with the "5 percent test" set forth in IRS Notice 88-129. This is not intended to be an exclusive list of the relevant conditions that must be met to conform to IRS requirements for non-taxable treatment.

At a Transmission Owner's request, Interconnection Customer shall provide such Transmission Owner with a report from an independent engineer confirming its

representation in clause (iii), above. Transmission Owners represents and covenant that the cost of Transmission Owners' Interconnection Facilities paid for by Interconnection Customer will have no net effect on the base upon which rates are determined.

5.17.3 Indemnification for the Cost Consequences of Current Tax Liability Imposed Upon the Transmission Owner. Notwithstanding Article 5.17.1, Interconnection Customer shall protect, indemnify and hold harmless each Transmission Owner from the cost consequences of any current tax liability imposed against a Transmission Owner as the result of payments or property transfers made by Interconnection Customer to a Transmission Owner under this Agreement for Interconnection Facilities, as well as any interest and penalties, other than interest and penalties attributable to any delay caused by a Transmission Owner.

Transmission Owner shall not include a gross-up for the cost consequences of any current tax liability in the amounts it charges Interconnection Customer under this Agreement unless (i) Transmission Owner has determined, in good faith, that the payments or property transfers made by Interconnection Customer to Transmission Owner should be reported as income subject to taxation or (ii) any Governmental Authority directs Transmission Owner to report payments or property as income subject to taxation; provided, however, that Transmission Owner may require Interconnection Customer to provide security for Interconnection Facilities, in a form reasonably acceptable to Transmission Owner, in an amount equal to the cost consequences of any current tax liability under this Article 5.17. Interconnection Customer shall reimburse Transmission Owner for such costs on a fully grossed-up basis, in accordance with Article 5.17.4, within thirty (30) Calendar Days of receiving written notification from Transmission Owner of the amount due, including detail about how the amount was calculated.

The indemnification obligation shall terminate at the earlier of (1) the expiration of the ten year testing period and the applicable statute of limitation, as it may be extended by Transmission Owner upon request of the IRS, to keep these years open for audit or adjustment, or (2) the occurrence of a subsequent taxable event and the payment of any related indemnification obligations as contemplated by this Article 5.17.

5.17.4 Tax Gross-Up Amount. Interconnection Customer's liability for the cost consequences of any current tax liability under this Article 5.17 shall be calculated on a fully grossed-up basis. Except as may otherwise be agreed to by the parties, this means that Interconnection Customer will pay Transmission Owner, in addition to the amount paid for the Interconnection Facilities and Network Upgrades, an amount equal to (1) the current taxes imposed on Transmission Owner ("Current Taxes") on the excess of (a) the gross income realized by Transmission Owner as a result of payments or property transfers made by Interconnection Customer to Transmission Owner under this Agreement (without regard to any payments under this Article 5.17) (the "Gross Income Amount") over (b) the present value of future tax deductions for depreciation that will be available as a result of such payments or property transfers (the "Present

Value Depreciation Amount”), plus (2) an additional amount sufficient to permit Transmission Owner to receive and retain, after the payment of all Current Taxes, an amount equal to the net amount described in clause (1).

For this purpose, (i) Current Taxes shall be computed based on Transmission Owner’s composite federal and state tax rates at the time the payments or property transfers are received and Transmission Owner will be treated as being subject to tax at the highest marginal rates in effect at that time (the “Current Tax Rate”), and (ii) the Present Value Depreciation Amount shall be computed by discounting Transmission Owner’s anticipated tax depreciation deductions as a result of such payments or property transfers by Transmission Owner’s current weighted average cost of capital. Thus, the formula for calculating Interconnection Customer’s liability to each respective Transmission Owner pursuant to this Article 5.17.4 can be expressed as follows: $(\text{Current Tax Rate} \times (\text{Gross Income Amount} - \text{Present Value of Tax Depreciation})) / (1 - \text{Current Tax Rate})$. Interconnection Customer’s estimated tax liability in the event taxes are imposed shall be stated in Appendices A-1, A-2, and A-3.

5.17.5 Private Letter Ruling or Change or Clarification of Law. At Interconnection Customer’s request and expense, Transmission Owner shall file with the IRS a request for a private letter ruling as to whether any property transferred or sums paid, or to be paid, by Interconnection Customer to Transmission Owner under this Agreement are subject to federal income taxation. Interconnection Customer will prepare the initial draft of the request for a private letter ruling, and will certify under penalties of perjury that all facts represented in such request are true and accurate to the best of Interconnection Customer’s knowledge. Transmission Owner and Interconnection Customer shall cooperate in good faith with respect to the submission of such request.

Transmission Owner shall keep Interconnection Customer fully informed of the status of such request for a private letter ruling and shall execute either a privacy act waiver or a limited power of attorney, in a form acceptable to the IRS, that authorizes Interconnection Customer to participate in all discussions with the IRS regarding such request for a private letter ruling. Transmission Owner shall allow Interconnection Customer to attend all meetings with IRS officials about the request and shall permit Interconnection Customer to prepare the initial drafts of any follow-up letters in connection with the request.

5.17.6 Subsequent Taxable Events. If, within 10 years from the date on which the relevant Transmission Owner’s Interconnection Facilities are placed in service, (i) Interconnection Customer Breaches the covenants contained in Article 5.17.2, (ii) a “disqualification event” occurs within the meaning of IRS Notice 88-129, or (iii) this Agreement terminates and Transmission Owner retains ownership of the Interconnection Facilities and Network Upgrades, Interconnection Customer shall pay a tax gross-up for the cost consequences of any current tax liability imposed on Transmission Owner, calculated using the methodology described in Article 5.17.4 and in accordance with IRS Notice 90-60.

5.17.7 Contests. In the event any Governmental Authority determines that a Transmission Owner’s receipt of payments or property constitutes income that is

subject to taxation, such Transmission Owner shall notify Interconnection Customer, in writing, within thirty (30) Calendar Days of receiving notification of such determination by a Governmental Authority. Upon the timely written request by Interconnection Customer and at Interconnection Customer's sole expense, such Transmission Owner may appeal, protest, seek abatement of, or otherwise oppose such determination. Upon Interconnection Customer's written request and sole expense, such Transmission Owner may file a claim for refund with respect to any taxes paid under this Article 5.17, whether or not it has received such a determination. Such Transmission Owner reserves the right to make all decisions with regard to the prosecution of such appeal, protest, abatement or other contest, including the selection of counsel and compromise or settlement of the claim, but such Transmission Owner shall keep Interconnection Customer informed, shall consider in good faith suggestions from Interconnection Customer about the conduct of the contest, and shall reasonably permit Interconnection Customer or an Interconnection Customer representative to attend contest proceedings.

Interconnection Customer shall pay to such Transmission Owner on a periodic basis, as invoiced by Transmission Owner, Transmission Owner's documented reasonable costs of prosecuting such appeal, protest, abatement or other contest. At any time during the contest, such Transmission Owner may agree to a settlement either with Interconnection Customer's consent or after obtaining written advice from nationally-recognized tax counsel, selected by such Transmission Owner, but reasonably acceptable to Interconnection Customer, that the proposed settlement represents a reasonable settlement given the hazards of litigation. Interconnection Customer's obligation shall be based on the amount of the settlement agreed to by Interconnection Customer, or if a higher amount, so much of the settlement that is supported by the written advice from nationally-recognized tax counsel selected under the terms of the preceding sentence. The settlement amount shall be calculated on a fully grossed-up basis to cover any related cost consequences of the current tax liability. Any settlement without Interconnection Customer's consent or such written advice will relieve Interconnection Customer from any obligation to indemnify such Transmission Owner for the tax at issue in the contest.

5.17.8 Refund. In the event that (a) a private letter ruling is issued to a Transmission Owner which holds that any amount paid or the value of any property transferred by Interconnection Customer to such Transmission Owner under the terms of this Agreement is not subject to federal income taxation, (b) any legislative change or administrative announcement, notice, ruling or other determination makes it reasonably clear to such Transmission Owner in good faith that any amount paid or the value of any property transferred by Interconnection Customer to such Transmission Owner under the terms of this Agreement is not taxable to such Transmission Owner, (c) any abatement, appeal, protest, or other contest results in a determination that any payments or transfers made by Interconnection Customer to such Transmission Owner are not subject to federal income tax, or (d) if such Transmission Owner receives a refund from any taxing authority for any overpayment of tax attributable to any payment or property transfer made by Interconnection Customer to such Transmission Owner

pursuant to this Agreement, such Transmission Owner shall promptly refund to Interconnection Customer the following:

(i) any payment made by Interconnection Customer under this Article 5.17 to such Transmission Owner for taxes that is attributable to the amount determined to be non-taxable, together with interest thereon,

(ii) interest on any amount paid by Interconnection Customer to such Transmission Owner for such taxes which Transmission Owner did not submit to the taxing authority, calculated in accordance with the methodology set forth in FERC's regulations at 18 CFR §35.19a(a)(2)(iii) from the date payment was made by Interconnection Customer to the date such Transmission Owner refunds such payment to Interconnection Customer, and

(iii) with respect to any such taxes paid by such Transmission Owner, any refund or credit such Transmission Owner receives or to which it may be entitled from any Governmental Authority, interest (or that portion thereof attributable to the payment described in clause (i), above) owed to such Transmission Owner for such overpayment of taxes (including any reduction in interest otherwise payable by such Transmission Owner to any Governmental Authority resulting from an offset or credit); provided, however, that such Transmission Owner will remit such amount promptly to Interconnection Customer only after and to the extent that such Transmission Owner has received a tax refund, credit or offset from any Governmental Authority for any applicable overpayment of income tax related to such Transmission Owner's Interconnection Facilities.

The intent of this provision is to leave the Parties, to the extent practicable, in the event that no taxes are due with respect to any payment for Transmission Owners' Interconnection Facilities and Network Upgrades hereunder, in the same position they would have been in had no such tax payments been made.

5.17.9 Taxes Other Than Income Taxes. Upon the timely request by Interconnection Customer, and at Interconnection Customer's sole expense, Transmission Owner or the CAISO may appeal, protest, seek abatement of, or otherwise contest any tax (other than federal or state income tax) asserted or assessed against Transmission Owner or the CAISO for which Interconnection Customer may be required to reimburse Transmission Owner or the CAISO under the terms of this Agreement. Interconnection Customer shall pay to Transmission Owner on a periodic basis, as invoiced by Transmission Owner, Transmission Owners' documented reasonable costs of prosecuting such appeal, protest, abatement, or other contest. Interconnection Customer, Transmission Owner and the CAISO if applicable, shall cooperate in good faith with respect to any such contest. Unless the payment of such taxes is a prerequisite to an appeal or abatement or cannot be deferred, no amount shall be payable by Interconnection Customer to Transmission Owner or the CAISO for such taxes until they are assessed by a final, non-appealable order by any court or agency of competent jurisdiction. In the event that a tax payment is withheld and ultimately due and payable after

appeal, Interconnection Customer will be responsible for all taxes, interest and penalties, other than penalties attributable to any delay caused by Transmission Owner or the CAISO.

5.18 Tax Status. Each Party shall cooperate with the others to maintain the other Parties' tax status. Nothing in this Agreement is intended to adversely affect any Transmission Owner's or the CAISO's tax exempt status with respect to the issuance of bonds including, but not limited to, Local Furnishing Bonds.

5.19 Modification.

5.19.1 General. The Interconnection Customer or the Transmission Owners may undertake modifications to their respective facilities, subject to the provisions of this Agreement and any applicable provisions of any applicable Tariff. If either the Interconnection Customer on the one hand, or Transmission Owners on the other hand, plan to undertake a modification that reasonably may be expected to affect the other's facilities, the Party planning the modification shall provide to the other Parties sufficient information regarding such modification so that the other Parties may evaluate the potential impact of such modification prior to commencement of the work or implementation of the modification. Such information shall be deemed to be confidential hereunder and shall include information concerning the timing of such modifications and whether such modifications are expected to interrupt the flow of electricity from the Large Generating Facility. The Party desiring to perform such work or implement the modification shall provide the relevant drawings, plans, and specifications to the other Parties at least ninety (90) Calendar Days in advance of the commencement of the work or implementation of the modification or such shorter period upon which the Parties may agree, which agreement shall not unreasonably be withheld, conditioned or delayed.

In the case of Large Generating Facility modifications that do not require Interconnection Customer to submit an Interconnection Request, Transmission Owners and the CAISO shall provide, within thirty (30) Calendar Days (or such other time as the Parties may agree), an estimate of any additional modifications to the Transmission Systems, Transmission Owners' Interconnection Facilities or Network Upgrades necessitated by such Interconnection Customer modification and a good faith estimate of the costs thereof. The Transmission Owners and the CAISO shall each determine if a Large Generating Facility modification is a Material Modification in accordance with their respective Large Generator Interconnection Procedures.

Notwithstanding anything in this Agreement to the contrary, any modification to the Large Generating Facility or the terms upon which Interconnection Service is provided hereunder that requires additional facilities beyond or in lieu of those facilities specifically identified in Appendices A-1, A-2, and A-3, including but not limited to additional Transmission Owners' Interconnection Facilities or Network Upgrades, shall be dealt with in a separate Large Generator Interconnection Agreement or in an amendment to this Agreement agreed to by all Parties; provided, however, that to the extent IID determines the modification

requires additional non-JPP facilities owned by IID, such change may be dealt with in a separate Affected System Study Agreement and/or Affected System Construction and Operation Agreement.

5.19.2 Standards. Any additions, modifications, or replacements made to the Transmission Systems or Transmission Owners' Interconnection Facilities that may reasonably be expected to affect the Generating Facility or Interconnection Facilities shall be designed, constructed and operated in accordance with this Agreement, Applicable Reliability Standards, and Good Utility Practice. Any additions, modifications, or replacements made to the Generating Facility or Interconnection Customer's Interconnection Facilities that may reasonably be expected to affect the Transmission Systems or Transmission Owners' Interconnection Facilities shall be designed, constructed and operated in accordance with this Agreement, Applicable Reliability Standards, and Good Utility Practice.

5.19.3 Modification Costs. Interconnection Customer shall not be directly assigned for the costs of any additions, modifications, or replacements that Transmission Owners make to Transmission Owners' Interconnection Facilities or to each respective Transmission Owner's Transmission System to facilitate the interconnection of a third party to Transmission Owners' Interconnection Facilities or the applicable Transmission Owner's Transmission System, or to provide transmission service to a third party under the applicable Tariff, *i.e.*, APS, IID and the CAISO. Interconnection Customer shall be responsible for the costs of any additions, modifications, or replacements to Interconnection Facilities that may be necessary to maintain or upgrade such Interconnection Facilities consistent with Applicable Laws and Regulations, Applicable Reliability Standards or Good Utility Practice.

Article 6. Testing and Inspection

6.1 Pre-Commercial Operation Date Testing and Modifications. Prior to the Commercial Operation Date, APS, on behalf of Transmission Owners, shall test Transmission Owners' Interconnection Facilities and Network Upgrades to the JPP in Appendices A-1 and A-2, and SDG&E shall test Network Upgrades to its non-JPP facilities in Appendix A-3. To the extent that the Affected System Study performed by IID identifies the need to install or construct any Network Upgrades to non-JPP facilities owned by IID, then IID shall test such Network Upgrades to non-JPP facilities prior to the Commercial Operation Date and Interconnection Customer shall test the Large Generating Facility and Interconnection Customer's Interconnection Facilities to ensure their safe and reliable operation. Similar testing may be required after initial operation. APS, on behalf of Transmission Owners, SDG&E, IID, and the Interconnection Customer shall make any modifications to their respective facilities that are found to be necessary as a result of such testing. The Interconnection Customer shall bear the cost of all such testing and modifications. The Interconnection Customer shall not commence initial parallel operation of the first Project Block for Phase A of the Generating Facility or the first Project Block of Phase B of the Generating Facility with the Transmission System until the Transmission Owners provide prior written approval, which shall not be unreasonably withheld, for operation of such Project Phase. Interconnection Customer shall generate

test energy at the Large Generating Facility only if it has arranged for the delivery of such test energy.

- 6.2 Post-Commercial Operation Date Testing and Modifications.** As between Transmission Owners for the JPP facilities in Appendices A-1 and A-2, SDG&E for its non-JPP facilities in Appendix A-3, and IID for its non-JPP facilities, if any are identified in the Affected System Study, respectively, and Interconnection Customer, each Party shall at its own expense perform routine inspection and testing of its facilities and equipment in accordance with Good Utility Practice as may be necessary to ensure the continued interconnection of the Large Generating Facility with the JPP in a safe and reliable manner. As between Transmission Owners for the JPP facilities in Appendices A-1 and A-2, SDG&E for its non-JPP facilities in Appendix A-3, and IID for its non-JPP facilities, if any are identified in the Affected System Study, respectively, and Interconnection Customer, each Party shall have the right, upon advance written notice, to require reasonable additional testing of the other Party's facilities, at the requesting Party's expense, as may be in accordance with Good Utility Practice.
- 6.3 Right to Observe Testing.** Each Party shall notify the other Parties at least fourteen (14) Calendar Days in advance of its performance of tests of its Interconnection Facilities or Generating Facility. The other Parties have the right, at their own expense, to observe such testing.
- 6.4 Right to Inspect.** Each Party shall have the right, but shall have no obligation to: (i) observe another Party's tests and/or inspection of any of its System Protection Facilities and other protective equipment, including Power System Stabilizers; (ii) review the settings of another Party's System Protection Facilities and other protective equipment; and (iii) review another Party's maintenance records relative to the Interconnection Facilities, the System Protection Facilities and other protective equipment. A Party may exercise these rights from time to time as it deems necessary upon reasonable notice to the other Party. The exercise or non-exercise by a Party of any such rights shall not be construed as an endorsement or confirmation of any element or condition of the Interconnection Facilities or the System Protection Facilities or other protective equipment or the operation thereof, or as a warranty as to the fitness, safety, desirability, or reliability of same. Any information that a Party obtains through the exercise of any of its rights under this Article 6.4 shall be deemed to be Confidential Information and treated pursuant to Article 22 of this Agreement.

Article 7. Metering

- 7.1 General.** Each Party shall comply with any Applicable Reliability Standards and the Applicable Reliability Council requirements. Unless otherwise agreed by the Parties, APS, on behalf of Transmission Owners, shall install Metering Equipment at the Point of Interconnection prior to any operation of the Large Generating Facility and shall own, operate, test and maintain such Metering Equipment. Power flows to and from the Large Generating Facility shall be measured at or, at Transmission Owners' option, compensated to, the Point of Interconnection. APS, on behalf of Transmission Owners, shall provide metering quantities, in analog and/or digital form, to Interconnection Customer upon request. Interconnection Customer shall bear all reasonable documented costs associated with the purchase, installation, operation, testing and maintenance of the Metering Equipment.

- 7.2 Check Meters.** Interconnection Customer, at its option and expense, may install and operate, on its premises and on its side of the Point of Interconnection, one or more check meters to check Transmission Owners' meters. Such check meters shall be for check purposes only and shall not be used for the measurement of power flows for purposes of this Agreement, except as provided in Article 7.4 below. The check meters shall be subject at all reasonable times to inspection and examination by APS, on behalf of Transmission Owners, or its designee. The installation, operation and maintenance thereof shall be performed entirely by Interconnection Customer in accordance with Good Utility Practice.
- 7.3 Standards.** APS, on behalf of Transmission Owners, shall install, calibrate, and test revenue quality Metering Equipment in accordance with applicable ANSI standards.
- 7.4 Testing of Metering Equipment.** APS, on behalf of Transmission Owners, shall inspect and test all Transmission Owner Metering Equipment for the JPP upon installation and at least once every two (2) years thereafter. If requested to do so by Interconnection Customer, APS, on behalf of Transmission Owners, shall, at Interconnection Customer's expense, inspect or test such Metering Equipment more frequently than every two (2) years. APS, on behalf of Transmission Owners, shall give reasonable notice of the time when any inspection or test shall take place, and Interconnection Customer may have representatives present at the test or inspection. If at any time Metering Equipment is found to be inaccurate or defective, it shall be adjusted, repaired or replaced at Interconnection Customer's expense, in order to provide accurate metering, unless the inaccuracy or defect is due to Transmission Owners' failure to maintain, then Transmission Owners shall pay. If Metering Equipment fails to register, or if the measurement made by Metering Equipment during a test varies by more than two percent from the measurement made by the standard meter used in the test, APS, on behalf of Transmission Owners, shall adjust the measurements by correcting all measurements for the period during which Metering Equipment was in error by using Interconnection Customer's check meters, if installed. If no such check meters are installed or if the period cannot be reasonably ascertained, the adjustment shall be for the period immediately preceding the test of the Metering Equipment equal to one-half the time from the date of the last previous test of the Metering Equipment.
- 7.5 Metering Data.** At Interconnection Customer's expense, the metered data shall be telemetered to one or more locations designated by Transmission Owners and one or more locations designated by Interconnection Customer. Subject to Article 7.6, such telemetered data shall be used, under normal operating conditions, as the official measurement of the amount of energy delivered from the Large Generating Facility to the Point of Interconnection.
- 7.6 Metering Requirements of CAISO.** Notwithstanding the other provisions of Article 7, if the Interconnection Customer elects the CAISO as the Balancing Authority for a Project Phase, the Interconnection Customer shall also comply with the metering requirements of the CAISO Tariff for such Phase, including installation of Metering Equipment in compliance with the requirements of the CAISO Tariff. For Phase A of the Generating Facility the Interconnection Customer has selected the CAISO as the Balancing Authority, so for Phase A of the Generating Facility, in addition to the requirements of this Article 7, the Interconnection Customer shall also comply with the

metering requirements of the CAISO Tariff. If the Interconnection Customer elects the CAISO as the Balancing Authority for Phase B of the Generating Facility pursuant to Article 9.2 of this Agreement, the Interconnection Customer shall also comply with the requirements of this Article 7 and the metering requirements of the CAISO Tariff for Phase B of the Generating Facility. Notwithstanding the provisions of Article 7.5, for any Project Phase in the CAISO Balancing Authority Area, data from the CAISO-compliant metering shall be used, under normal operating conditions, as the official measurement of the amount of energy delivered from the Large Generating Facility to the Point of Interconnection. Any Metering Equipment installed by APS on behalf of the Transmission Owners will serve as an alternative source for meter data for the CAISO in the event of failure of the CAISO-compliant metering to provide accurate meter data.

Article 8. Communications

- 8.1 Interconnection Customer Obligations.** Interconnection Customer shall maintain satisfactory operating communications with APS's Transmission System dispatcher or representative designated by APS, and with CAISO, to the extent CAISO is selected by Interconnection Customer as Balancing Authority for a Project Phase. Interconnection Customer shall provide standard voice line, dedicated voice line and facsimile communications at its Large Generating Facility control room or central dispatch facility through use of either the public telephone system, or a voice communications system that does not rely on the public telephone system. Interconnection Customer shall also provide the dedicated data circuit(s) necessary to provide Interconnection Customer data to APS, on behalf of Transmission Owners as set forth in Appendix D, Security Arrangements Details, and as applicable, to CAISO. The data circuit(s) shall extend from the Large Generating Facility to the location(s) specified by APS, on behalf of Transmission Owners, and the CAISO. Any required maintenance of such communications equipment shall be performed by Interconnection Customer. Operational communications shall be activated and maintained under, but not be limited to, the following events: system paralleling or separation, scheduled and unscheduled shutdowns, equipment clearances, and hourly and daily load data.
- 8.2 Remote Terminal Unit.** Prior to the Initial Synchronization Date of any Project Phase, a Remote Terminal Unit, or equivalent data collection and transfer equipment acceptable to the Parties, shall be installed by Interconnection Customer, or by APS, on behalf of Transmission Owners, at Interconnection Customer's expense, to gather accumulated and instantaneous data to be telemetered to the location(s) designated by APS, on behalf of Transmission Owners, through use of a dedicated point-to-point data circuit(s) as indicated in Article 8.1. The communication protocol for the data circuit(s) shall be specified by APS, on behalf of Transmission Owners. Instantaneous bi-directional analog real power and reactive power flow information must be telemetered directly to the location(s) specified by APS.

As among APS, on behalf of Transmission Owners, CAISO and Interconnection Customer, each such Party will promptly advise the other Parties if it detects or otherwise learns of any metering, telemetry or communications equipment errors or malfunctions that require the attention and/or correction by the other Parties. The Party owning such equipment shall correct such error or malfunction as soon as reasonably feasible.

- 8.3 No Annexation.** Any and all equipment placed on the premises of a Party shall be and remain the property of the Party providing such equipment regardless of the mode and manner of annexation or attachment to real property, unless otherwise mutually agreed by the Parties.
- 8.4 Communication Requirements of CAISO.** Notwithstanding the other provisions of Article 8, if the Interconnection Customer elects the CAISO as the Balancing Authority for a Project Phase, the Interconnection Customer shall also comply with the communications requirements of the CAISO Tariff. For Phase A of the Generating Facility the Interconnection Customer has selected the CAISO as the Balancing Authority, so for Phase A of the Generating Facility, in addition to the requirements of this Article 8, the Interconnection Customer shall also comply with the communications requirements of the CAISO Tariff. If the Interconnection Customer elects the CAISO as the Balancing Authority for Phase B of the Generating Facility pursuant to Article 9.2 of this Agreement, the Interconnection Customer shall also comply with the requirements of this Article 8 and the communications requirements of the CAISO Tariff for Phase B of the Generating Facility.

Article 9. Operations

- 9.1 General.** Each Party shall comply with Applicable Reliability Standards and the Applicable Reliability Council requirements. Each Party shall provide to the other Parties all information that may reasonably be required by the other Parties to comply with Applicable Laws and Regulations and Applicable Reliability Standards.
- 9.2 Balancing Authority Area Notification.** At least three months before Initial Synchronization Date of a Project Phase, Interconnection Customer shall notify APS and the CAISO in writing of the Balancing Authority Area in which that Project Phase will be located, if and as permitted by the relevant transmission tariffs, including the APS and CAISO Tariffs. All necessary arrangements, including but not limited to those set forth in Articles 7 and 8 of this Agreement, and remote Balancing Authority Area generator interchange agreements, if applicable, and the appropriate measures under such agreements, shall be executed and implemented prior to the placement a Project Phase in the designated Balancing Authority Area. Separate notifications will be required for each Project Phase, as specified in Appendix C.
- 9.3 Transmission Owner and CAISO Obligations.** The Transmission Owners and the CAISO shall cause their respective Transmission Systems and APS, on behalf of Transmission Owners, shall cause the Transmission Owners' Interconnection Facilities to be operated, maintained and controlled in a safe and reliable manner and in accordance with this Agreement. APS and the CAISO may provide operating instructions to Interconnection Customer consistent with this Agreement and APS's or the CAISO's operating protocols and procedures as they may change from time to time. APS and the CAISO will consider changes to their respective operating protocols and procedures proposed by Interconnection Customer.
- 9.4 Interconnection Customer Obligations.** Interconnection Customer shall at its own expense operate, maintain and control the Large Generating Facility and Interconnection Customer's Interconnection Facilities in a safe and reliable manner and in accordance with this Agreement. Interconnection Customer shall operate the Large Generating

Facility and Interconnection Customer's Interconnection Facilities in accordance with all applicable requirements of the Balancing Authority Area of which it is part, as such requirements are set forth in Appendix C, Interconnection Details, of this Agreement. Appendix C, Interconnection Details, will be modified to reflect changes to the requirements as they may change from time to time. A Party may request that the other Parties provide copies of the requirements set forth in Appendix C, Interconnection Details, of this Agreement.

9.5 Start-Up and Synchronization. Consistent with the Parties' mutually acceptable procedures, Interconnection Customer is responsible for the proper synchronization of the Large Generating Facility to the JPP.

9.6 Reactive Power.

9.6.1 Power Factor Design Criteria. Interconnection Customer shall design Phase A of the Large Generating Facility to maintain a composite power delivery at continuous rated power output at the Point of Interconnection at a power factor within the range of 0.95 leading to 0.95 lagging, which power factor range shall supersede any otherwise applicable power factor range set forth in the CAISO Tariff. The Interconnection Customer shall design Phase B of the Large Generating Facility to maintain a composite power delivery at continuous rated power output at the Point of Interconnection at a power factor within the range of 0.95 leading to 0.95 lagging or the Applicable Reliability Standard in effect at the time the Interconnection Studies for Phase B of the Generating Facility are performed. For Phase B of the Generating Facility, the Interconnection Studies for that Project Phase demonstrate or shall demonstrate that that Project Phase complies with Article 9.6.1 before Phase B of the Interconnection Project commences Trial Operation.

9.6.2 Voltage Schedules. APS shall be responsible for compliance with Applicable Reliability Standards related to reactive power and voltage schedules for the interconnection of the Large Generating Facility to the JPP, subject to any agreement entered into by APS and the CAISO regarding the allocation of responsibilities for compliance with Applicable Reliability Standards. Pursuant to that responsibility, once Interconnection Customer has synchronized the Large Generating Facility with the JPP, APS shall require Interconnection Customer to operate the Large Generating Facility to produce or absorb reactive power within the design limitations of the Large Generating Facility set forth in Article 9.6.1 (Power Factor Design Criteria), Appendix C, and the Interconnection Customer's data, as revised, that were provided for the Interconnection Studies. Voltage schedules required by APS shall treat all sources of reactive power interconnected to the JPP in an equitable and not unduly discriminatory manner. APS shall exercise Reasonable Efforts to provide Interconnection Customer with such schedules at least one (1) day in advance, and may make changes to such schedules as necessary to maintain the reliability of the Transmission Systems. Interconnection Customer shall operate the Large Generating Facility to maintain the specified output voltage or power factor at the Point of Interconnection within the design limitations of the Large Generating Facility set forth in Article 9.6.1 (Power Factor Design Criteria), and the Interconnection Customer's data, as revised, that were provided for the Interconnection Studies. If Interconnection

Customer is unable to maintain the specified voltage or power factor, it shall promptly notify the APS system operator.

9.6.2.1 Governors and Regulators. To the extent required by Applicable Reliability Standards, the Interconnection Customer shall procure, install, and maintain governors and regulators. To the extent required by Applicable Reliability Standards, whenever the Large Generating Facility is operated in parallel with the Transmission System and the speed governors (if installed on the generating unit pursuant to Good Utility Practice) and voltage regulators are capable of operation, Interconnection Customer shall operate the Large Generating Facility with its speed governors and voltage regulators in automatic operation. If the Large Generating Facility's speed governors and voltage regulators are not capable of such automatic operation, Interconnection Customer shall immediately notify APS and the CAISO and ensure that such Large Generating Facility operates as specified in Article 9.6.2 through manual operation and that its reactive power production or absorption (measured in MVARs) are within the design capability of the Large Generating Facility's generating unit(s) and steady state stability limits. The Interconnection Customer shall restore the speed governors and voltage regulators to automatic operation as soon as possible. If the Large Generating Facility's speed governors and voltage regulators are improperly tuned or malfunctioning, APS or the CAISO shall have the right to order the reduction in output or disconnection of the Large Generating Facility if the reliability of the Transmission System would be adversely affected. Interconnection Customer shall not cause its Large Generating Facility to disconnect automatically or instantaneously from the Transmission System or trip any generating unit comprising the Large Generating Facility for an under or over frequency condition unless the abnormal frequency condition persists for a time period beyond the limits set forth in ANSI/IEEE Standard C37.106, or such other standard as applied to other generators interconnecting to the JPP on a comparable basis.

9.6.3 Payment for Reactive Power. APS is required to pay Interconnection Customer for reactive power that Interconnection Customer provides or absorbs from the Large Generating Facility when APS requests Interconnection Customer to operate its Large Generating Facility outside the range specified in Article 9.6.1, provided that if APS pays its own or affiliated generators for reactive power service within the specified range, it must also pay Interconnection Customer. Payments shall be pursuant to Article 11.6 or such other agreement to which the Parties have otherwise agreed.

9.7 Outages and Interruptions.

9.7.1 Outages.

9.7.1.1 Outage Authority and Coordination. Each Party may in accordance with Good Utility Practice in coordination with the other Parties remove from service any of its respective Interconnection Facilities or Network

Upgrades that may impact the other Parties' facilities as necessary to perform maintenance or testing or to install or replace equipment, provided that the Interconnection Customer shall also coordinate outages of the Generating Facility with the CAISO pursuant to the provisions of the CAISO Tariff for each Project Phase that is within the CAISO Balancing Authority Area, and APS shall coordinate outages of the JPP and Transmission Owner Interconnection Facilities with the CAISO in accordance with agreed procedures. Absent an Emergency Condition, the Party scheduling a removal of such facility(ies) from service will use Reasonable Efforts to schedule such removal on a date and time mutually acceptable to the Parties. In all circumstances, any Party planning to remove such facility(ies) from service shall use Reasonable Efforts to minimize the effect on the other Party of such removal.

9.7.1.2 Outage Schedules. APS, IID and CAISO shall post scheduled outages of their respective transmission facilities in accordance with applicable Tariff requirements. Interconnection Customer shall submit its planned maintenance schedules for the Large Generating Facility to APS for a minimum of a rolling twenty-four month period and to the CAISO in accordance with the CAISO Tariff for any Project Phase in the CAISO Balancing Authority Area. Interconnection Customer shall update its planned maintenance schedules as necessary, including providing updates to the CAISO in accordance with the CAISO Tariff. APS, on behalf of Transmission Owners, and the CAISO, in accordance with the applicable provisions of the CAISO Tariff, may request Interconnection Customer to reschedule its maintenance as necessary to maintain the reliability of Transmission Owners' and the CAISO Transmission Systems; provided, however, adequacy of generation supply shall not be a criterion in determining Transmission System reliability, subject to Section 9 of the CAISO Tariff. APS shall compensate Interconnection Customer for any additional direct costs that Interconnection Customer incurs as a result of having to reschedule maintenance, including any additional overtime, breaking of maintenance contracts or other costs above and beyond the cost Interconnection Customer would have incurred absent APS's request to reschedule maintenance. The CAISO shall compensate Interconnection Customer for any additional direct costs that Interconnection Customer incurs as a result of having to reschedule maintenance in accordance with the CAISO Tariff. Interconnection Customer will not be eligible to receive compensation, if during the twelve (12) months prior to the date of the scheduled maintenance, Interconnection Customer had modified its schedule of maintenance activities.

9.7.1.3 Outage Restoration. If an outage on a Party's Interconnection Facilities or Network Upgrades adversely affects another Party's operations or facilities, the Party that owns or controls the facility that is out of service shall use Reasonable Efforts to promptly restore such facility(ies) to a normal operating condition consistent with the nature of the outage. The Party that owns or controls the facility that is out of service shall provide the other Parties, to the extent such information is known, information on

the nature of the Emergency Condition, if the outage is caused by an Emergency Condition, an estimated time of restoration, and any corrective actions required. Initial verbal notice shall be followed up as soon as practicable with written notice explaining the nature of the outage, if requested by a Party, which may be provided by e-mail or facsimile.

9.7.2 Interruption of Service. If required by Good Utility Practice to do so, APS, on behalf of the Transmission Owners, may require Interconnection Customer to interrupt or reduce deliveries of electricity if such delivery of electricity could adversely affect the ability of APS to perform such activities as are necessary to safely and reliably operate and maintain the Transmission System. If the Interconnection Customer elects the CAISO as the Balancing Authority for a Project Phase, the CAISO may also have authority to require Interconnection Customer to curtail or interrupt such generation in accordance with the procedures established for generators in the CAISO Balancing Authority Area, in which case the procedures established by the CAISO pursuant to the CAISO Tariff shall apply in lieu of the provisions of this Article 9.7.2. APS or the CAISO shall notify the other as soon as possible of any curtailment, interruption, or reduction of deliveries from the Large Generating Facility that it may require. The following provisions shall apply to any interruption or reduction by APS permitted under this Article 9.7.2:

- 9.7.2.1** The interruption or reduction shall continue only for so long as reasonably necessary under Good Utility Practice;
- 9.7.2.2** Any such interruption or reduction shall be made on an equitable, non-discriminatory basis with respect to all generating facilities directly connected to its Transmission System;
- 9.7.2.3** When the interruption or reduction must be made under circumstances which do not allow for advance notice, APS shall notify Interconnection Customer by telephone as soon as practicable of the reasons for the curtailment, interruption, or reduction, and, if known, its expected duration. Telephone notification shall be followed by written notification, if requested by the Interconnection Customer, as soon as practicable;
- 9.7.2.4** Except during the existence of an Emergency Condition, when the interruption or reduction can be scheduled without advance notice, APS shall notify Interconnection Customer in advance regarding the timing of such scheduling and further notify Interconnection Customer of the expected duration. APS shall coordinate with Interconnection Customer using Good Utility Practice to schedule the interruption or reduction during periods of least impact to Interconnection Customer, and APS, acting on behalf of the Transmission Owners;
- 9.7.2.5** The Parties shall cooperate and coordinate with each other to the extent necessary in order to restore the Large Generating Facility, Interconnection Facilities, and their Transmission Systems to their

normal operating state, consistent with system conditions and Good Utility Practice.

9.7.3 Under-Frequency and Over Frequency Conditions. The Transmission System is designed to automatically activate a load-shed program as required by Applicable Reliability Standards and the Applicable Reliability Council in the event of an under-frequency system disturbance. Interconnection Customer shall implement under-frequency and over-frequency protection set points for the Large Generating Facility as required by the Applicable Reliability Standards and Applicable Reliability Council to ensure “ride through” capability of the Transmission System. Large Generating Facility response to frequency deviations of pre-determined magnitudes, both under-frequency and over-frequency deviations, shall be studied and coordinated with APS and the CAISO in accordance with Good Utility Practice. The term “ride through” as used herein shall mean the ability of a Generating Facility to stay connected to and synchronized with the Transmission System during system disturbances within a range of under-frequency and over-frequency conditions, in accordance with Good Utility Practice.

9.7.4 System Protection and Other Control Requirements.

9.7.4.1 System Protection Facilities. Interconnection Customer shall, at its expense, install, operate and maintain System Protection Facilities as a part of the Large Generating Facility or Interconnection Customer’s Interconnection Facilities. Transmission Owners shall install at Interconnection Customer’s expense any System Protection Facilities that may be required on Transmission Owners’ Interconnection Facilities and their Transmission Systems as a result of the interconnection of the Large Generating Facility and Interconnection Customer’s Interconnection Facilities.

9.7.4.2 The Transmission Owners’ and Interconnection Customer’s protection facilities shall be designed and coordinated with other systems in accordance with Applicable Reliability Standards, Applicable Reliability Council criteria and Good Utility Practice.

9.7.4.3 The Transmission Owners and Interconnection Customer shall be responsible for protection of their respective facilities consistent with Good Utility Practice.

9.7.4.4 The Transmission Owners’ and Interconnection Customer’s protective relay design shall incorporate the necessary test switches to perform the tests required in Article 6. The required test switches will be placed such that they allow operation of lockout relays while preventing breaker failure schemes from operating and causing unnecessary breaker operations and/or the tripping of Interconnection Customer’s units.

9.7.4.5 The Transmission Owners and Interconnection Customer will cause to be tested, operated and maintained System Protection Facilities in accordance with Good Utility Practice.

9.7.4.6 Prior to the in-service date, and again prior to the Commercial Operation Date, the Transmission Owners and Interconnection Customer or their respective agents shall perform a complete calibration test and functional trip test of the System Protection Facilities. At intervals suggested by Good Utility Practice and following any apparent malfunction of the System Protection Facilities, the Transmission Owners and Interconnection Customer shall perform both calibration and functional trip tests of their respective System Protection Facilities. These tests do not require the tripping of any in-service generation unit. These tests do, however, require that all protective relays and lockout contacts be activated.

9.7.5 Requirements for Protection. In compliance with Good Utility Practice, Interconnection Customer shall provide, install, own, and maintain relays, circuit breakers and all other devices necessary to remove any fault contribution of the Large Generating Facility to any short circuit occurring on the Transmission System not otherwise isolated by Transmission Owners' respective equipment, such that the removal of the fault contribution shall be coordinated with the protective requirements of the Transmission System. Such protective equipment shall include, without limitation, a disconnecting device or switch with fault current-interrupting capability located between the Large Generating Facility and the JPP at a site selected upon mutual agreement (not to be unreasonably withheld, conditioned or delayed) of the Parties. Interconnection Customer shall be responsible for protection of the Large Generating Facility and Interconnection Customer's other equipment from such conditions as negative sequence currents, over- or under-frequency, sudden load rejection, over- or under-voltage, and generator loss-of-field. Interconnection Customer shall be solely responsible to disconnect the Large Generating Facility and Interconnection Customer's other equipment if conditions on the Transmission System could adversely affect the Large Generating Facility.

9.7.6 Power Quality. Neither Party's facilities shall cause excessive voltage flicker nor introduce excessive distortion to the sinusoidal voltage or current waves as defined by ANSI Standard C84.1-1989, in accordance with IEEE Standard 519, or any applicable superseding electric industry standard or Applicable Reliability Standard. In the event of a conflict among ANSI Standard C84.1-1989, any applicable superseding electric industry standard or Applicable Reliability Standard, the Applicable Reliability Standard shall control.

9.8 Switching and Tagging Rules. APS, on behalf of Transmission Owners, and the Interconnection Customer shall provide each other a copy of its switching and tagging rules that are applicable to the other's activities. Such switching and tagging rules shall be developed on a non-discriminatory basis. APS, on behalf of Transmission Owners, and Interconnection Customer shall comply with applicable switching and tagging rules, as amended from time to time, in obtaining clearances for work or for switching operations on equipment.

9.9 Use of Interconnection Facilities by Third Parties.

- 9.9.1 Purpose of Interconnection Facilities.** Except as may be required by Applicable Laws and Regulations, or as otherwise agreed to among the Parties, the Interconnection Facilities shall be constructed for the sole purpose of interconnecting the Large Generating Facility to the JPP and shall be used for no other purpose.
- 9.9.2 Third Party Users.** If required by Applicable Laws and Regulations or if the Parties mutually agree, such agreement not to be unreasonably withheld, to allow one or more third parties to use Transmission Owners' Interconnection Facilities, or any part thereof, Interconnection Customer will be entitled to compensation for the capital expenses it incurred in connection with the Interconnection Facilities based upon the pro rata use of the Interconnection Facilities by each Transmission Owner, third party user, and Interconnection Customer, in accordance with Applicable Laws and Regulations or upon some other mutually-agreed upon methodology. In addition, cost responsibility for ongoing costs, including operation and maintenance costs associated with the Interconnection Facilities, will be allocated between Interconnection Customer and any third party users based upon the pro rata use of the Interconnection Facilities by each Transmission Owner, third party user, and Interconnection Customer, in accordance with Applicable Laws and Regulations or upon some other mutually agreed upon methodology. If the issue of such compensation or allocation cannot be resolved through such negotiations, it shall be submitted to arbitration pursuant to Article 27 of this Agreement or, if a complaint is made against a FERC jurisdictional public utility that is a Party to this Agreement, to FERC for resolution with respect to that FERC jurisdictional public utility.
- 9.10 Disturbance Analysis Data Exchange.** The Parties will cooperate with one another in the analysis of disturbances to either the Large Generating Facility or the Transmission Systems by gathering and providing access to any information relating to any disturbance, including information from oscillography, protective relay targets, breaker operations and sequence of events records, and any disturbance information required by Good Utility Practice.

Article 10. Maintenance

- 10.1 Transmission Owner Obligations.** Transmission Owners shall maintain the Transmission Owners' Transmission Systems and Transmission Owners' Interconnection Facilities in a safe and reliable manner and in accordance with this Agreement.
- 10.2 Interconnection Customer Obligations.** Interconnection Customer shall maintain the Large Generating Facility and Interconnection Customer's Interconnection Facilities in a safe and reliable manner and in accordance with this Agreement.
- 10.3 Coordination.** APS, on behalf of Transmission Owners, Interconnection Customer and the CAISO shall confer regularly to coordinate the planning, scheduling and performance of preventive and corrective maintenance on the Large Generating Facility and the Interconnection Facilities, which maintenance coordination shall be consistent with Article 9.7.1.

- 10.4 Secondary Systems.** APS, on behalf of Transmission Owners, Interconnection Customer and the CAISO shall cooperate with each other in the inspection, maintenance, and testing of control or power circuits that operate below 600 volts, AC or DC, including, but not limited to, any hardware, control or protective devices, cables, conductors, electric raceways, secondary equipment panels, transducers, batteries, chargers, and voltage and current transformers that directly affect the operation of such Parties' facilities and equipment which may reasonably be expected to impact the other Parties. APS, on behalf of Transmission Owners, Interconnection Customer and the CAISO shall provide advance notice to each other before undertaking any work on such circuits, especially on electrical circuits involving circuit breaker trip and close contacts, current transformers, or potential transformers.
- 10.5 Operating and Maintenance Expenses.** Subject to the provisions herein addressing the use of facilities by others, and except for operations and maintenance expenses associated with modifications made for providing interconnection or transmission service to a third party and such third party pays for such expenses, Interconnection Customer shall be responsible for all reasonable expenses including overheads, associated with: (1) owning, operating, maintaining, repairing, and replacing Interconnection Customer's Interconnection Facilities; and (2) operation, maintenance, repair and replacement of Transmission Owners' Interconnection Facilities.

Article 11. Performance Obligation

- 11.1 Interconnection Customer Interconnection Facilities.** Interconnection Customer shall design, procure, construct, install, own and/or control Interconnection Customer Interconnection Facilities described in Appendices A-1 and A-2 at its sole expense.
- 11.2 Transmission Owners' Interconnection Facilities.** APS, on behalf of Transmission Owners, shall design, procure, construct, install, own and/or control the Transmission Owners' Interconnection Facilities described in Appendices A-1 and A-2 at the sole expense of the Interconnection Customer.
- 11.3 Network Upgrades and Distribution Upgrades.** APS, on behalf of Transmission Owners shall design, procure, construct, and install, and the Transmission Owners shall jointly own the JPP Network Upgrades and Distribution Upgrades described in Appendices A-1 and A-2. SDG&E shall design, procure, construct, install, and own the non-JPP Network Upgrades described in Appendix A-3. Unless Transmission Owners, individually or collectively, elect to fund the capital for the Network Upgrades, they shall be solely funded by Interconnection Customer. For Network Upgrades to SDG&E's Transmission System, including SDG&E's share of the JPP, the amount of Interconnection Customer's cost responsibility to SDG&E shall be determined pursuant to the methodology set forth in Section 12.3.1 and Appendix 2 of the CAISO's Large Generator Interconnection Procedures.
- 11.4 Transmission Credits.**
- 11.4.1 Repayment of Amounts Advanced to APS for Network Upgrades to APS's Share of the JPP.** Interconnection Customer shall be entitled to a cash repayment from APS, equal to the total amount paid by Interconnection Customer to Transmission Owners for the Network Upgrades to the JPP

identified in Appendices A-1 and A-2, and not refunded to Interconnection Customer pursuant to Article 5.17.8 or otherwise, times APS's percentage Ownership Interest in the JPP ("APS's pro rata amount"), plus any tax gross-up or other tax-related payments associated with APS's pro rata amount, to be paid to Interconnection Customer on a dollar-for-dollar basis for the non-usage sensitive portion of transmission charges, as payments are made under APS's Tariff applicable to transmission services on APS's Transmission System with respect to the Large Generating Facility. Such repayment shall include interest calculated in accordance with the methodology set forth in FERC's regulations at 18 C.F.R. § 35.19a(a)(2)(iii) from the date of any payment for JPP Network Upgrades through the date on which the Interconnection Customer receives a repayment of such payment pursuant to this subparagraph. Interconnection Customer may assign such repayment rights to any person.

Notwithstanding the foregoing, Interconnection Customer and APS may adopt an alternative payment schedule that is mutually agreeable so long as APS takes one of the following actions no later than five years from the Commercial Operation Date for a Project Phase: (1) returns to Interconnection Customer any of its pro rata amounts advanced for JPP Network Upgrades not previously repaid, or (2) declares in writing that APS will continue to provide payments to Interconnection Customer on a dollar-for-dollar basis for the non-usage sensitive portion of transmission charges, or develop an alternative schedule that is mutually agreeable and provides for the return of all its pro rata amounts advanced for Network Upgrades not previously repaid; however, full reimbursement by APS of its pro rata amount shall not extend beyond twenty (20) years from the Commercial Operation Date for a Project Phase, and further, if this Agreement terminates within five (5) years from the Commercial Operation Date for that Project Phase, APS's obligation to pay refunds to the Interconnection Customer shall cease as of the date of termination.

If the Large Generating Facility fails to achieve Commercial Operation for a Project Phase, but it or another Generating Facility is later constructed and makes use of the Network Upgrades to the JPP associated with that Project Phase, APS shall at that time reimburse Interconnection Customer for APS's pro rata amount advanced to it for the JPP Network Upgrades for the Project Phase. Before any such reimbursement can occur, the Interconnection Customer, or the entity that ultimately constructs the Generating Facility, if different, is responsible for identifying and demonstrating to APS the entity to which reimbursement must be made in order to implement the intent of this reimbursement obligation.

11.4.2 Repayment of Amounts Advanced to SDG&E for Network Upgrades to Its Share of the JPP and to Its Non-JPP Facilities.

Upon the Commercial Operation Date for a Project Phase, the Interconnection Customer shall be entitled to a repayment, equal to the total amount paid by Interconnection Customer to SDG&E for the Network Upgrades to the JPP identified in Appendices A-1 and A-2, and not refunded to Interconnection Customer pursuant to Article 5.17.8 or otherwise, times SDG&E's percentage Ownership Interest in the JPP ("SDG&E's pro rata amount"), plus any amount paid to SDG&E for the costs of Network Upgrades to non-JPP facilities owned

by SDG&E set forth in Appendix A-3 and not refunded to Interconnection Customer pursuant to Article 5.17.8 or otherwise (“SDG&E’s individual amount”), plus any tax gross-up or other tax-related payments associated with Network Upgrades and not refunded to the Interconnection Customer pursuant to Article 5.17.8 or otherwise, and shall be paid to the Interconnection Customer by SDG&E on a dollar-for-dollar basis either through (1) direct payments made on a levelized basis over the five-year period commencing on the Commercial Operation Date for a Project Phase; or (2) any alternative payment schedule that is mutually agreeable to the Interconnection Customer and SDG&E, provided that such amount is paid within five (5) years from the Commercial Operation Date for a Project Phase. *See also* Appendices A-1 and A-2. Notwithstanding the foregoing, if this Agreement terminates within five (5) years from the Commercial Operation Date for that Project Phase, SDG&E’s obligation to pay refunds to the Interconnection Customer shall cease as of the date of termination. Any repayment shall include interest calculated in accordance with the methodology set forth in FERC’s regulations at 18 C.F.R. §35.19a(a)(2)(iii) from the date of any payment for Network Upgrades through the date on which the Interconnection Customer receives a repayment of such payment. Interest shall continue to accrue on the repayment obligation so long as this Agreement is in effect. The Interconnection Customer may assign such repayment rights to any person.

If the Large Generating Facility fails to achieve Commercial Operation for a Project Phase, but it or another Generating Facility is later constructed and makes use of the Network Upgrades associated with that Project Phase, SDG&E shall at that time reimburse Interconnection Customer for SDG&E’s pro rata amount and the individual amount advanced to SDG&E for the Network Upgrades for the Project Phase. Before any such reimbursement can occur, the Interconnection Customer, or the entity that ultimately constructs the Generating Facility, if different, is responsible for identifying and demonstrating to SDG&E the appropriate entity to which reimbursement must be made in order to implement the intent of this reimbursement obligation.

11.4.3 Repayment of Amounts Advanced to IID for Network Upgrades to IID’s Share of the JPP. The Parties acknowledge that IID is not a jurisdictional public utility subject to FERC’s rate jurisdiction under Section 205 or 206 of the Federal Power Act. The responsibility to provide transmission rate credits, under FERC’s generation interconnection regulations, therefore does not extend to IID. *See* Order No. 2003-C, 111 FERC ¶ 61,401, at P 18 (2005)(citing Order No. 2003, 104 FERC ¶ 61,103, at P 843 (2003)). Notwithstanding its non-jurisdictional status, IID hereby agrees to provide transmission rate credits to Interconnection Customer (or any other qualified person to whom Interconnection Customer assigns its rights to such transmission rate credits) when Point-to-Point Transmission Service is taken on IID’s share of the JPP as follows: IID shall provide such rate credits in an amount equal to the total amount paid by Interconnection Customer to Transmission Owners for the Network Upgrades to the JPP identified in Appendices A-1 and A-2 and not refunded to Interconnection Customer pursuant to Article 5.17.8 or otherwise, times IID’s percentage Ownership Interest in the JPP (“IID’s pro rata amount”). Such rate credits shall be provided by IID on a dollar-for-dollar basis for the non-

usage sensitive portion of IID's transmission charges (i.e., the demand charge for reserved capacity), as payments are made by Interconnection Customer (or any other qualified person to whom Interconnection Customer assigns its rights to transmission rate credits) to IID under IID's Open Access Transmission Tariff, for a period no longer than twenty (20) years from the Commercial Operation Date for a Project Phase. Notwithstanding the foregoing, if this Agreement terminates within five (5) years from the Commercial Operation Date for that Project Phase, IID's obligation to pay refunds to the Interconnection Customer shall cease as of the date of termination. IID also hereby agrees that Interconnection Customer may assign its rights to such transmission rate credits to any person which qualifies as an Eligible Customer for Point-to-Point Transmission Service under IID's Open Access Transmission Tariff.

If the Large Generating Facility fails to achieve Commercial Operation for a Project Phase, but it or another Generating Facility is later constructed and makes use of the Network Upgrades to the JPP associated with that Project Phase, IID shall reimburse Interconnection Customer for IID's pro rata amount advanced to it for the JPP Network Upgrades for the Project Phase, provided that IID receives payment of those amounts from the entity making use of the JPP Network Upgrades. Before any such reimbursement can occur, the Interconnection Customer, or the entity that ultimately constructs the Generating Facility, if different, is responsible for identifying and demonstrating to IID the appropriate entity to which reimbursement must be made in order to implement the intent of this reimbursement obligation.

11.4.4 Special Provisions for Affected Systems. Interconnection Customer and any Affected System Operator shall enter into a separate agreement that provides for the repayment of amounts advanced to such Affected System Operator for Network Upgrades. The agreement shall specify the terms governing payments to be made by Interconnection Customer to the Affected System Operator as well as the repayment by the Affected System Operator.

The Parties acknowledge that an Affected System Study must be performed by IID to analyze system impacts and identify the Network Upgrades, if any, that are required to IID's Transmission System, including its non-JPP facilities, to accommodate Interconnection Requests received by the CAISO from interconnection customers in the CAISO's Transition Cluster, as defined in the CAISO's LGIP, including the Interconnection Customer that is a Party to this Agreement. IID and Interconnection Customer have executed or will execute an Affected System Study Agreement for Phase A of the Generating Facility, whereby IID will perform and Interconnection Customer will pay the costs of an Affected System Study. The total costs will be pro rated to the extent IID performs the Affected System Study in a cluster for multiple generators seeking to interconnect to the CAISO controlled grid, with Interconnection Customer allocated a proportionate share of the total costs. Subject to the terms of a mutually-acceptable Non-Disclosure Agreement between the CAISO and IID, the CAISO shall provide to IID its applicable base case Interconnection Study data to assist IID in performing the Affected System Study.

The Parties acknowledge that there may be a need for an Affected System Study for Phase B of the Generating Facility, as provided for in Appendix C to this Agreement.

If an Affected System Study shows that Network Upgrades are required to IID's Transmission System, other than IID's share of the JPP, Interconnection Customer and IID agree that they shall enter into an Affected System Construction and Operation Agreement and that failure of the Interconnection Customer or IID to enter into such an agreement in accordance with the terms of this Article shall be considered a breach of this Agreement. The Interconnection Customer and IID agree that pursuant to the Affected System Construction and Operation Agreement: (1) Interconnection Customer shall fund the costs of constructing Network Upgrades reasonably attributable to Interconnection Customer; (2) IID shall use Reasonable Efforts to construct any Network Upgrades to IID's non-JPP facilities needed to accommodate Interconnection Customer's Interconnection Request to the CAISO on a schedule consistent with the provisions regarding testing in Article 6.1 of this Agreement; and (3) to the extent that the Interconnection Customer provides funding for any IID Network Upgrades identified in the Affected System Study, IID shall provide rate credits for the amount of such funding, which has not otherwise been refunded, applied on a dollar-for-dollar basis to the non-usage sensitive portion of IID's transmission charges (i.e., the demand charge for reserved capacity), as payments are made by Interconnection Customer (or any other qualified person to whom Interconnection Customer assigns its rights to transmission rate credits) under IID's Tariff, for a period no longer than twenty (20) years from the Commercial Operation Date for the Project Phase.

Any disputes between Interconnection Customer and IID regarding the Affected System Study Agreement or Affected System Construction and Operation Agreement shall be resolved pursuant to the dispute resolution procedures in Section 13.5 of the Generation Interconnection Procedures in IID's Tariff.

11.4.5 Notwithstanding any other provision of this Agreement, nothing herein shall be construed as relinquishing or foreclosing any rights, including but not limited to firm transmission rights, capacity rights, transmission congestion rights, "Congestion Revenue Rights" defined in and available pursuant to the terms of the CAISO Tariff, or transmission credits, that Interconnection Customer, shall be entitled to, now or in the future, under any other agreement or tariff as a result of, or otherwise associated with, the transmission capacity, if any, created by the Network Upgrades, including the right to obtain cash reimbursements, merchant transmission "Congestion Revenue Rights" in accordance with Section 36.11 of the CAISO Tariff, or transmission credits for transmission service that is not associated with the Large Generating Facility.

11.5 Provision of Security. With regard to SDG&E's share of costs to be incurred for Transmission Owners' Interconnection Facilities and Network Upgrades to the JPP identified in Appendices A-1 and A-2, and for SDG&E's costs of Network Upgrades identified in Appendix A-3, the Interconnection Customer shall provide (or cause to be provided) all necessary Interconnection Financial Security required under Section 9 of the CAISO's LGIP in a manner acceptable under Section 9 of the CAISO's LGIP.

Failure to satisfy the CAISO's LGIP's requirements for the provision of Interconnection Financial Security shall result in the Interconnection Request being deemed withdrawn and subject to CAISO LGIP Section 3.8.

With regard to APS and IID's shares of the costs to be incurred for Interconnection Facilities and Network Upgrades to the JPP identified in Appendices A-1 and A-2, at least thirty (30) Calendar Days prior to the commencement of the procurement, installation, or construction of Transmission Owners' Interconnection Facilities and JPP Network Upgrades, the Interconnection Customer shall provide (or cause to be provided) APS, on behalf of APS and IID, a guarantee, a surety bond, letter of credit or other form of security that is reasonably acceptable to APS and IID, and is consistent with the Uniform Commercial Code of the jurisdiction identified in Article 14.2.1. Such security for payment shall be in an amount sufficient to cover the costs for constructing, procuring and installing both APS and IID's shares of the Transmission Owners' Interconnection Facilities and JPP Network Upgrades set forth in Appendices A-1 and A-2, and shall be reduced on a dollar-for-dollar basis for payments made to APS, on behalf of APS and IID, for these purposes.

The Parties agree that APS, as the Operating Agent of the JPP under the Participation Agreement, and solely as agent for APS and IID, will accept delivery of the financial security required for the APS and IID shares of the Transmission Owners' Interconnection Facilities and Network Upgrades to the JPP set forth in Appendices A-1 and A-2, which the Interconnection Customer is required to provide (or cause to be provided) in accordance with the milestone schedule set forth in Appendices B-1 and B-2. APS's receipt of any such financial security will be solely as agent for APS and IID, and APS shall have no obligations to the Interconnection Customer with regard to such financial security other than any obligation it may have for the APS and IID shares of such financial security; APS shall have all obligations, if any, to the Interconnection Customer for the APS and IID shares of such financial security. If it becomes necessary for the Transmission Owners to enforce their financial security rights, APS shall do so, as Operating Agent of the JPP, on behalf of APS and IID in accordance with the procedures set forth in Appendices A-1 and A-2.

SDG&E shall hold the Interconnection Financial Security required for SDG&E's Ownership Share in accordance with the requirements of the CAISO Tariff, provided, however, that if it becomes necessary for the Transmission Owners to enforce their financial security rights, SDG&E shall do so in accordance with the CAISO Tariff and the procedures set forth in Appendices A-1 and A-2.

In addition to complying with all requirements of the CAISO's Large Generator Interconnection Procedures regarding Interconnection Financial Security for security provided to SDG&E:

11.5.1 Any guarantee provided to APS, on behalf of APS and IID, and/or SDG&E, as applicable, must be made by an entity that meets the creditworthiness requirements of APS and IID and/or SDG&E, as applicable, and contain terms and conditions that guarantee payment of any amount that may be due from Interconnection Customer, up to an agreed-to maximum amount.

11.5.2 Any letter of credit to APS, on behalf of APS and IID, and/or SDG&E, , as applicable, must be issued by a financial institution reasonably acceptable to APS and IID and/or SDG&E, as applicable, and must specify a reasonable expiration date.

11.5.3 Any surety bond to APS, on behalf of APS and IID, and/or SDG&E, as applicable, must be issued by an insurer reasonably acceptable to APS and IID and/or SDG&E, as applicable, and must specify a reasonable expiration date.

Security shall be provided separately for Phase A of the Interconnection Project and Phase B of the Interconnection Project. Failure of the Interconnection Customer to have any required financial security in place at any time shall constitute grounds for termination of this Agreement pursuant to Articles 2.3 and 17.1, provided, however, Interconnection Customer shall have only 5 (five) Business Days to cure such failure following notice of the default. In addition to the foregoing, the obligation of Transmission Owners to perform under this Agreement is suspended until such failure is cured.

11.6 Interconnection Customer Compensation. If a Transmission Owner or the CAISO requests or directs Interconnection Customer to provide a service pursuant to 13.5.1 of this Agreement, the Transmission Owner or the CAISO requesting service shall compensate Interconnection Customer in accordance with its Tariff.

11.6.1 Interconnection Customer Compensation for Actions During Emergency Condition. The Transmission Owner or the CAISO requesting the Interconnection Customer to provide service during an Emergency Condition shall compensate Interconnection Customer for its provision of real and reactive power and other Emergency Condition services that Interconnection Customer provides to support its Transmission System during an Emergency Condition in accordance with Article 11.6.

Article 12. Invoice

12.1 General Provisions. For purposes of this Article, as between APS, on behalf of Transmission Owners of the JPP, and Interconnection Customer, each such Party shall submit to the other Party, on a monthly basis, invoices of amounts due for the preceding month with respect to JPP facilities. As between SDG&E, as owner of certain non-JPP facilities under this Agreement, and Interconnection Customer, each such Party shall submit to the other Party, on a monthly basis, invoices of amounts due for the preceding month for such non-JPP facilities owned solely by SDG&E.

Each invoice shall state the month to which the invoice applies and fully describe the services and equipment provided. The Parties may discharge mutual debts and payment obligations due and owing to each other on the same date through netting, in which case all amounts a Party owes to the other Party under this Agreement, including interest payments or credits, shall be netted so that only the net amount remaining due shall be paid by the owing Party; provided, however, that the Parties shall not net amounts relating to JPP facilities with those related to non-JPP facilities. Notwithstanding the foregoing, any invoices between the CAISO and another Party pursuant to the CAISO Tariff shall be submitted and paid in accordance with the CAISO Tariff.

Invoices shall be provided separately for Phase A of the Interconnection Project and Phase B of the Interconnection Project.

- 12.2 Final Invoice.** Within six months after completion of the construction of Transmission Owners' Interconnection Facilities and the Network Upgrades to the JPP for Phase A of the Interconnection Project and Phase B of the Interconnection Project, APS, on behalf of Transmission Owners, with respect to the Transmission Owners' Interconnection Facilities and JPP Network Upgrades identified in Appendices A-1 and A-2 and SDG&E with respect to its non-JPP Network Upgrades identified in Appendix A-3, shall each provide an invoice of the final cost of the construction of their respective Transmission Owners' Interconnection Facilities and the Network Upgrades and shall set forth such costs in sufficient detail to enable Interconnection Customer to compare the actual costs with the estimates and to ascertain deviations, if any, from the cost estimates.

With respect to costs associated with the Transmission Owners' Interconnection Facilities and the JPP Network Upgrades, APS, on behalf of Transmission Owners, shall refund to Interconnection Customer any amount by which the actual payment by Interconnection Customer for the estimated costs of such facilities exceeds the actual costs of construction within thirty (30) Calendar Days of the issuance of such final construction invoice; or, in the event the actual costs of construction exceed the Interconnection Customer's actual payment for estimated costs, then the Interconnection Customer shall pay to APS, on behalf of the Transmission Owners, any amount by which the actual costs of construction exceed the actual payment by the Interconnection Customer for the estimated costs within thirty (30) Calendar Days of the issuance of such final construction invoice.

With respect to costs associated with SDG&E's non-JPP Network Upgrades identified in Appendix A-3, SDG&E shall be responsible for refunding to the Interconnection Customer any amount by which the actual payment by the Interconnection Customer for estimated costs of such facilities exceeds the actual costs of construction, within thirty (30) Calendar Days of the issuance of such final construction invoice. In the event the actual costs of construction multiplied by the Interconnection Customer's percentage share of those costs exceed the Interconnection Customer's actual payment for estimated costs, then SDG&E shall be responsible for recovering such difference through its transmission service rates.

Invoices shall be provided separately for Phase A of the Interconnection Project and Phase B of the Interconnection Project.

- 12.3 Payment.** Invoices shall be rendered to the paying Party at the address specified in Appendix F. The Party receiving the invoice shall pay the invoice within thirty (30) Calendar Days of receipt. All payments shall be made in immediately available funds payable to the other Party, or by wire transfer to a bank named and account designated by the invoicing Party. Payment of invoices by either Party will not constitute a waiver of any rights or claims either Party may have under this Agreement.

- 12.4 Disputes.** In the event of a billing dispute between Transmission Owners and Interconnection Customer, Transmission Owners and the CAISO shall continue to provide Interconnection Service under this Agreement as long as Interconnection

Customer: (i) continues to make all payments not in dispute; and (ii) pays to Transmission Owners or into an independent escrow account the portion of the invoice in dispute, pending resolution of such dispute. If Interconnection Customer fails to meet these two requirements for continuation of service, then Transmission Owners may provide notice to Interconnection Customer of a Default pursuant to Article 17. Within thirty (30) Calendar Days after the resolution of the dispute, the Party that owes money to the other Party shall pay the amount due with interest calculated in accord with the methodology set forth in FERC's regulations at 18 CFR § 35.19a(a)(2)(iii). Notwithstanding the foregoing, any billing dispute between the CAISO, Interconnection Customer and/or SDG&E shall be resolved in accordance with the provisions of Article 27 of this Agreement.

Article 13. Emergencies

- 13.1 Definition.** "Emergency Condition" shall have the meaning set forth in Article 1.
- 13.2 Obligations.** Interconnection Customer, SDG&E and the CAISO shall comply with the Emergency Condition procedures of the CAISO, and all Parties shall comply with the Emergency Condition procedures of NERC, the Applicable Reliability Council, Applicable Reliability Standards, Applicable Laws and Regulations, and any emergency procedures set forth in this Agreement or agreed to by the Joint Operating Committee that are consistent with the other Emergency Condition procedures with which compliance is required by this Article 13.2.
- 13.3 Notice.** With respect to any facility which a Transmission Owner or the CAISO controls, the Transmission Owner or the CAISO shall notify Interconnection Customer promptly when it becomes aware of an Emergency Condition that affects Transmission Owners' Interconnection Facilities or such Transmission Owner's or the CAISO's Transmission System that may reasonably be expected to affect Interconnection Customer's operation of the Large Generating Facility or Interconnection Customer's Interconnection Facilities. Interconnection Customer shall notify Transmission Owners and the CAISO promptly when it becomes aware of an Emergency Condition that affects the Large Generating Facility or Interconnection Customer's Interconnection Facilities that may reasonably be expected to affect the Transmission Systems or Transmission Owners' Interconnection Facilities. To the extent information is known, the notification shall describe the Emergency Condition, the extent of the damage or deficiency, the expected effect on the operation of Interconnection Customer's or such Transmission Owner's or the CAISO's facilities and operations, its anticipated duration and the corrective action taken and/or to be taken. The initial notice shall be followed as soon as practicable with written notice, if requested by a Party, which may be provided by electronic mail or facsimile, or in the case of the CAISO may be publicly posted on the CAISO's internet website.
- 13.4 Immediate Action.** Unless, in Interconnection Customer's reasonable judgment, immediate action is required, Interconnection Customer shall obtain the consent of APS and the CAISO, such consent to not be unreasonably withheld, prior to performing any manual switching operations at the Large Generating Facility or Interconnection Customer's Interconnection Facilities in response to an Emergency Condition either declared by APS, on behalf of the Transmission Owners, or the CAISO or otherwise regarding the Transmission Systems.

13.5 Transmission Owner and CAISO Authority.

13.5.1 General. Transmission Owners and the CAISO may take whatever actions or inactions with regard to their affected Transmission Systems or Transmission Owners' Interconnection Facilities they deem necessary during an Emergency Condition in order to (i) preserve public health and safety, (ii) preserve the reliability of the affected Transmission Systems or Transmission Owners' Interconnection Facilities, (iii) limit or prevent damage, and (iv) expedite restoration of service.

Transmission Owners and the CAISO shall use Reasonable Efforts to minimize the effect of such actions or inactions on the Large Generating Facility or Interconnection Customer's Interconnection Facilities. APS, on behalf of Transmission Owners, and the CAISO may, on the basis of technical considerations, require the Large Generating Facility to mitigate an Emergency Condition by taking actions necessary and limited in scope to remedy the Emergency Condition, including, but not limited to, directing Interconnection Customer to shut-down, start-up, increase or decrease the real or reactive power output of the Large Generating Facility; implementing a reduction or disconnection pursuant to Article 13.5.2; directing Interconnection Customer to assist with blackstart (if available) or restoration efforts; or altering the outage schedules of the Large Generating Facility and Interconnection Customer's Interconnection Facilities. Subject to the provisions of Articles 9.6.1 and 9.6.2, Interconnection Customer shall comply with all of APS's operating instructions concerning Large Generating Facility real power and reactive power output within the manufacturer's design limitations of the Large Generating Facility's equipment that is in service and physically available for operation at the time, in compliance with Applicable Laws and Regulations and Applicable Reliability Standards.

13.5.2 Reduction and Disconnection. APS, on behalf of Transmission Owners, or the CAISO may reduce Interconnection Service, and APS may disconnect the Large Generating Facility or Interconnection Customer's Interconnection Facilities, when such reduction or disconnection is necessary under Good Utility Practice due to Emergency Conditions. These rights are separate and distinct from any right of curtailment of Transmission Owners or the CAISO pursuant to their respective Tariffs. When APS, on behalf of Transmission Owners, or the CAISO can schedule the reduction or disconnection in advance, APS or the CAISO shall notify Interconnection Customer of the reasons, timing and expected duration of the reduction or disconnection and shall coordinate with the other in accordance with Articles 9.7.1 and 9.7.2. APS and the CAISO shall coordinate with Interconnection Customer using Good Utility Practice to schedule the reduction or disconnection during periods of least impact to Interconnection Customer and Transmission Owners and the CAISO. Any reduction or disconnection shall continue only for so long as reasonably necessary under Good Utility Practice. The Parties shall cooperate with each other to restore the Large Generating Facility, the Interconnection Facilities, and the Transmission System to their normal operating state as soon as practicable consistent with Good Utility Practice.

- 13.6 Interconnection Customer Authority.** Consistent with Good Utility Practice, this Agreement and applicable Tariffs, Interconnection Customer may take actions or inactions with regard to the Large Generating Facility or Interconnection Customer's Interconnection Facilities during an Emergency Condition in order to (i) preserve public health and safety, (ii) preserve the reliability of the Large Generating Facility or Interconnection Customer's Interconnection Facilities, (iii) limit or prevent damage, and (iv) expedite restoration of service. Interconnection Customer shall use Reasonable Efforts to minimize the effect of such actions or inactions on the affected Transmission System(s) and Transmission Owners' Interconnection Facilities. Each affected Transmission Owner and the CAISO shall use Reasonable Efforts to assist Interconnection Customer in such actions.
- 13.7 Limited Liability.** Except as otherwise provided in Article 11.6.1 of this Agreement, no Party shall be liable to the others for any action it takes in responding to an Emergency Condition so long as such action is made in good faith and is consistent with Good Utility Practice.

Article 14. Regulatory Requirements and Governing Law

- 14.1 Regulatory Requirements.** A Party's obligations under this Agreement shall be subject to its receipt of any required approval or certificate from one or more Governmental Authorities in the form and substance satisfactory to the applying Party, or the Party making any required filings with, or providing notice to, such Governmental Authorities, and the expiration of any time period associated therewith. A Party shall in good faith seek and use its Reasonable Efforts to obtain such other approvals. Nothing in this Agreement shall require Interconnection Customer or other Party to take any action that could result in its inability to obtain, or its loss of, status or exemption under the Federal Power Act, the Public Utility Holding Company Act of 1935, as amended, or the Public Utility Regulatory Policies Act of 1978.
- 14.2 Governing Law.**
- 14.2.1** The validity, interpretation and performance of this Agreement and each of its provisions shall be governed by the laws of the state where the Point of Interconnection is located, without regard to its conflicts of law principles.
- 14.2.2** This Agreement is subject to all Applicable Laws and Regulations.
- 14.2.3** Each Party expressly reserves the right to seek changes in, appeal, or otherwise contest any laws, orders, rules, or regulations of a Governmental Authority.

Article 15. Notices.

- 15.1 General.** Unless otherwise provided in this Agreement, any notice, demand or request required or permitted to be given by a Party to the others and any instrument required or permitted to be tendered or delivered by a Party in writing to the others shall be effective when delivered and may be so given, tendered or delivered, by recognized national courier, or by depositing the same with the United States Postal Service with postage prepaid, for delivery by certified or registered mail, addressed to the Parties, or personally

delivered to the Parties, at the address set out in Appendix F, Addresses for Delivery of Notices and Billings.

A Party must update the information in Appendix F as information changes. A Party may change the notice information in this Agreement by giving five (5) Business Days written notice prior to the effective date of the change. Such changes shall not constitute an amendment to this Agreement.

- 15.2 Billings and Payments.** Billings and payments shall be sent to the addresses set out in Appendix F.
- 15.3 Alternative Forms of Notice.** Any notice or request required or permitted to be given by a Party to the other and not required by this Agreement to be given in writing may be so given by telephone, facsimile or email to the telephone numbers and email addresses set out in Appendix F.
- 15.4 Operations and Maintenance Notice.** APS and the CAISO shall notify the other Parties in writing of the identity of the person(s) that they designate as the point(s) of contact with respect to the implementation of Articles 9 and 10.

Article 16. Force Majeure

16.1 Force Majeure.

16.1.1 Economic hardship is not considered a Force Majeure event.

16.1.2 No Party shall be considered to be in Default with respect to any obligation hereunder, (including obligations under Article 4), other than the obligation to pay money when due, if prevented from fulfilling such obligation by Force Majeure. A Party unable to fulfill any obligation hereunder (other than an obligation to pay money when due) by reason of Force Majeure shall give notice and the full particulars of such Force Majeure to the other Parties in writing or by telephone as soon as reasonably possible after the occurrence of the cause relied upon. Telephone notices given pursuant to this article shall be confirmed in writing as soon as reasonably possible and shall specifically state full particulars of the Force Majeure, the time and date when the Force Majeure occurred and when the Force Majeure is reasonably expected to cease. The Party affected shall exercise due diligence to remove such disability with reasonable dispatch, but shall not be required to accede or agree to any provision not satisfactory to it in order to settle and terminate a strike or other labor disturbance.

Article 17. Default

17.1 Default

17.1.1 General. No Default shall exist where such failure to discharge an obligation (other than the payment of money or posting of security) is the result of Force Majeure as defined in this Agreement or the result of an act of omission of the other Parties. Upon a Breach, the affected non-Breaching Parties shall give written notice of such Breach to the Breaching Party. Except as provided in

Article 17.1.2, the Breaching Party shall have thirty (30) Calendar Days from receipt of the Default notice within which to cure such Breach; provided however, if such Breach is not capable of cure within thirty (30) Calendar Days, the Breaching Party shall commence such cure within thirty (30) Calendar Days after notice and continuously and diligently complete such cure within ninety (90) Calendar Days from receipt of the Default notice; and, if cured within such time, the Breach specified in such notice shall cease to exist. If one but not both of the entities comprising the Interconnection Customer breaches this Agreement, the non-Breaching Party shall accept performance from the Interconnection Customer entity to the extent it continues to perform under this Agreement.

17.1.2 Right to Terminate. If a Breach is not cured as provided in this article or as provided in Article 11.5.3 with respect to the posting of financial security, or if a Breach is not capable of being cured within the period provided for herein, an affected non-Breaching Party shall have the right to declare a Default and terminate this Agreement by written notice at any time until cure occurs, and be relieved of any further obligation hereunder and, whether or not that Party terminates this Agreement, to recover from the Breaching Party all amounts due hereunder, plus all other damages and remedies to which it is entitled at law or in equity. The provisions of this article will survive termination of this Agreement.

Article 18. Indemnity, Consequential Damages and Insurance

18.1 Indemnity. A Party shall at all times indemnify, defend, and hold another Party, harmless from, any and all Losses arising out of or resulting from that particular Party's actions or inactions of its obligations under this Agreement on behalf of the indemnifying Party, except in cases of gross negligence or intentional wrongdoing by the indemnified Party.

18.1.1 Indemnified Party. If an indemnified Party is entitled to indemnification under this Article 18 as a result of a claim by a third party, and the indemnifying Party fails, after notice and reasonable opportunity to proceed under Article 18.1, to assume the defense of such claim, such indemnified Party may at the expense of the indemnifying Party contest, settle or consent to the entry of any judgment with respect to, or pay in full, such claim.

18.1.2 Indemnifying Party. If an indemnifying Party is obligated to indemnify and hold any indemnified Party harmless under this Article 18, the amount owing to the indemnified Party shall be the amount of such indemnified Party's actual Loss, net of any insurance or other recovery.

18.1.3 Indemnity Procedures. Promptly after receipt by an indemnified Party of any claim or notice of the commencement of any action or administrative or legal proceeding or investigation as to which the indemnity provided for in Article 18.1 may apply, the indemnified Party shall notify the indemnifying Party of such fact. Any failure of or delay in such notification shall not affect a Party's indemnification obligation unless such failure or delay is materially prejudicial to the indemnifying Party.

The indemnifying Party shall have the right to assume the defense thereof with counsel designated by such indemnifying Party and reasonably satisfactory to the indemnified Party. If the defendants in any such action include one or more indemnified Parties and the indemnifying Party and if the indemnified Party reasonably concludes that there may be legal defenses available to it and/or other indemnified Parties which are different from or additional to those available to the indemnifying Party, the indemnified Party shall have the right to select separate counsel to assert such legal defenses and to otherwise participate in the defense of such action on its own behalf. In such instances, the indemnifying Party shall only be required to pay the fees and expenses of one additional attorney to represent an indemnified Party or indemnified Parties having such differing or additional legal defenses.

The indemnified Party shall be entitled, at its expense, to participate in any such action, suit or proceeding, the defense of which has been assumed by the indemnifying Party. Notwithstanding the foregoing, the indemnifying Party (i) shall not be entitled to assume and control the defense of any such action, suit or proceedings if and to the extent that, in the opinion of the indemnified Party and its counsel, such action, suit or proceeding involves the potential imposition of criminal liability on the indemnified Party, or there exists a conflict or adversity of interest between the indemnified Party and the indemnifying Party, in such event the indemnifying Party shall pay the reasonable expenses of the indemnified Party, and (ii) shall not settle or consent to the entry of any judgment in any action, suit or proceeding without the consent of the indemnified Party, which shall not be reasonably withheld, conditioned or delayed.

18.2 Consequential Damages. In no event shall a Party be liable under any provision of this Agreement for any losses, damages, costs or expenses for any special, indirect, incidental, consequential, or punitive damages, including but not limited to loss of profit or revenue, loss of the use of equipment, cost of capital, cost of temporary equipment or services, whether based in whole or in part in contract, in tort, including negligence, strict liability, or any other theory of liability; provided, however, that damages for which a Party may be liable to another Party under another agreement will not be considered to be special, indirect, incidental, or consequential damages hereunder.

18.3 Insurance. A Party shall, at its own expense, maintain in force throughout the period of this Agreement, and until released by the other Party(ies), the following minimum insurance coverages, with insurers authorized to do business in the state where the Point of Interconnection is located:

18.3.1 Employer's Liability and Workers' Compensation Insurance providing statutory benefits in accordance with the laws and regulations of the state in which the Point of Interconnection is located, except in the case of the CAISO, the State of California.

18.3.2 Commercial General Liability Insurance including premises and operations, personal injury, broad form property damage, broad form blanket contractual liability coverage (including coverage for the contractual indemnification) products and completed operations coverage, coverage for explosion, collapse and underground hazards, independent contractors coverage, coverage for

pollution to the extent normally available and punitive damages to the extent normally available and a cross liability endorsement, with minimum limits of One Million Dollars (\$1,000,000) per occurrence/One Million Dollars (\$1,000,000) aggregate combined single limit for personal injury, bodily injury, including death and property damage.

- 18.3.3** Business Automobile Liability Insurance for coverage of owned and non-owned and hired vehicles, trailers or semi-trailers designed for travel on public roads, with a minimum, combined single limit of One Million Dollars (\$1,000,000) per occurrence for bodily injury, including death, and property damage.
- 18.3.4** Excess Public Liability Insurance over and above the Employer's Liability Commercial General Liability and Business Automobile Liability Insurance coverage, with a minimum combined single limit of Twenty Million Dollars (\$20,000,000) per occurrence/Twenty Million Dollars (\$20,000,000) aggregate.
- 18.3.5** The Commercial General Liability Insurance, Business Automobile Insurance and Excess Public Liability Insurance policies shall name the other Party, their parents, associated and Affiliate companies and their respective directors, officers, agents, servants and employees ("Other Party Group") as additional insured. All policies shall contain provisions whereby the insurers waive all rights of subrogation in accordance with the provisions of this Agreement against the Other Party Group and provide thirty (30) Calendar Days advance written notice to the Other Party Group prior to anniversary date of cancellation or any material change in coverage or condition.
- 18.3.6** The Commercial General Liability Insurance, Business Automobile Liability Insurance and Excess Public Liability Insurance policies shall contain provisions that specify that the policies are primary and shall apply to such extent without consideration for other policies separately carried and shall state that each insured is provided coverage as though a separate policy had been issued to each, except the insurer's liability shall not be increased beyond the amount for which the insurer would have been liable had only one insured been covered. Each Party shall be responsible for its respective deductibles or retentions.
- 18.3.7** The Commercial General Liability Insurance, Business Automobile Liability Insurance and Excess Public Liability Insurance policies, if written on a Claims First Made Basis, shall be maintained in full force and effect for two (2) years after termination of this Agreement, which coverage may be in the form of tail coverage or extended reporting period coverage if agreed by the Parties.
- 18.3.8** The requirements contained herein as to the types and limits of all insurance to be maintained by the Parties are not intended to and shall not in any manner, limit or qualify the liabilities and obligations assumed by the Parties under this Agreement.
- 18.3.9** Within ten (10) Calendar Days following execution of this Agreement, and as soon as practicable after the end of each fiscal year or at the renewal of the insurance policy and in any event within ninety (90) Calendar Days thereafter,

each Party shall provide certification of all insurance required in this Agreement, executed by each insurer or by an authorized representative of each insurer.

18.3.10 Notwithstanding the foregoing, each Party may self-insure to meet the minimum insurance requirements of Articles 18.3.2 through 18.3.8 to the extent it maintains a self-insurance program; provided that, such Party's senior unsecured debt or issuer rating is BBB-, or better as rated by Standard & Poor's and that its self-insurance program meets the minimum insurance requirements of Articles 18.3.2 through 18.3.8. For any period of time that a Party's senior unsecured debt rating and issuer rating are both rated at less than BBB- by Standard & Poor's, such Party shall comply with the insurance requirements applicable to it under Articles 18.3.2 through 18.3.9. In the event that a Party is permitted to self-insure pursuant to this article, it shall notify the other Parties that it meets the requirements to self-insure and that its self-insurance program meets the minimum insurance requirements in a manner consistent with that specified in Article 18.3.9.

18.3.11 The Parties agree to report to each other in writing as soon as practical all accidents or occurrences resulting in injuries to any person, including death, and any property damage arising out of this Agreement.

Article 19. Assignment

19.1 Assignment. This Agreement may be assigned by a Party only with the written consent of the other Parties; provided that a Party may assign this Agreement without the consent of the other Parties to any Affiliate of the assigning Party with an equal or greater credit rating and with the legal authority and operational ability to satisfy the obligations of the assigning Party under this Agreement; and provided further that Interconnection Customer shall have the right to assign this Agreement, without the consent of the other Parties, for collateral security purposes to aid in providing financing for the Large Generating Facility or a Project Phase of the Large Generating Facility, provided that Interconnection Customer will promptly notify the Parties of any such assignment. Any financing arrangement entered into by Interconnection Customer pursuant to this article will provide that prior to or upon the exercise of the secured party's, trustee's or mortgagee's assignment rights pursuant to said arrangement, the secured creditor, the trustee or mortgagee will notify the Parties of the date and particulars of any such exercise of assignment right(s), including providing the Parties with proof that it meets the requirements of Articles 11.5 and 18.3. Any attempted assignment that violates this article is void and ineffective. Any assignment under this Agreement shall not relieve a Party of its obligations, nor shall a Party's obligations be enlarged, in whole or in part, by reason thereof. Where required, consent to assignment will not be unreasonably withheld, conditioned or delayed.

Article 20. Severability

20.1 Severability. If any provision in this Agreement is finally determined to be invalid, void or unenforceable by any court or other Governmental Authority having jurisdiction, such determination shall not invalidate, void or make unenforceable any other provision, agreement or covenant of this Agreement; provided that if Interconnection Customer (or any third party, but only if such third party is not acting at the direction of a Transmission

Owner or the CAISO) seeks and obtains such a final determination with respect to any provision of the Alternate Option (Article 5.1.2), or the Negotiated Option (Article 5.1.4), then none of these provisions shall thereafter have any force or effect and the Parties' rights and obligations shall be governed solely by the Standard Option (Article 5.1.1).

Article 21. Comparability

21.1 Comparability. The Parties which are FERC-jurisdictional public utilities will comply with all applicable comparability and code of conduct laws, rules and regulations, as amended from time to time. For clarity and avoidance of ambiguity, IID is not a jurisdictional public utility to whom Section 205 or 206 of the Federal Power Act or FERC rules and regulations thereunder apply.

Article 22. Confidentiality

22.1 Confidentiality. Confidential Information shall include, without limitation, all information relating to a Party's technology, research and development, business affairs, and pricing, and any information supplied by any of the Parties to the other prior to the execution of this Agreement.

Information is Confidential Information only if it is clearly designated or marked in writing as confidential on the face of the document, or, if the information is conveyed orally or by inspection, if the Party providing the information orally informs the Parties receiving the information that the information is confidential.

If requested by any Party, the other Parties shall provide in writing, the basis for asserting that the information referred to in this Article 22 warrants confidential treatment, and the requesting Party may disclose such writing to the appropriate Governmental Authority. Each Party shall be responsible for the costs associated with affording confidential treatment to its information.

22.1.1 Term. During the term of this Agreement, and for a period of three (3) years after the expiration or termination of this Agreement, except as otherwise provided in this Article 22, each Party shall hold in confidence and shall not disclose to any person Confidential Information.

22.1.2 Scope. Confidential Information shall not include information that the receiving Party can demonstrate: (1) is generally available to the public other than as a result of a disclosure by the receiving Party; (2) was in the lawful possession of the receiving Party on a non-confidential basis before receiving it from the disclosing Party; (3) was supplied to the receiving Party without restriction by a third party, who, to the knowledge of the receiving Party after due inquiry, was under no obligation to the disclosing Party to keep such information confidential; (4) was independently developed by the receiving Party without reference to Confidential Information of the disclosing Party; (5) is, or becomes, publicly known, through no wrongful act or omission of the receiving Party or Breach of this Agreement; or (6) is required, in accordance with Article 22.1.7 of the Agreement, Order of Disclosure, to be disclosed by any Governmental Authority or is otherwise required to be disclosed by law or subpoena, or is necessary in any legal proceeding establishing rights and obligations under this Agreement.

Information designated as Confidential Information will no longer be deemed confidential if the Party that designated the information as confidential notifies the other Parties that it no longer is confidential.

- 22.1.3 Release of Confidential Information.** No Party shall release or disclose Confidential Information to any other person, except to its Affiliates (limited by the Standards of Conduct requirements set forth in Part 358 of FERC's Regulations, 18 C.F.R. 358), subcontractors, employees, consultants, or to parties who may be or considering providing financing to or equity participation with Interconnection Customer, or to potential purchasers or assignees of Interconnection Customer, on a need-to-know basis in connection with this Agreement, unless such person has first been advised of the confidentiality provisions of this Article 22 and has agreed to comply with such provisions. Notwithstanding the foregoing, a Party providing Confidential Information to any person shall remain primarily responsible for any release of Confidential Information in contravention of this Article 22.
- 22.1.4 Rights.** Each Party retains all rights, title, and interest in the Confidential Information that each Party discloses to the other Parties. The disclosure by each Party to the other Parties of Confidential Information shall not be deemed a waiver by a Party or any other person or entity of the right to protect the Confidential Information from public disclosure.
- 22.1.5 No Warranties.** By providing Confidential Information, no Party makes any warranties or representations as to its accuracy or completeness. In addition, by supplying Confidential Information, no Party obligates itself to provide any particular information or Confidential Information to the other Parties nor to enter into any further agreements or proceed with any other relationship or joint venture.
- 22.1.6 Standard of Care.** A Party shall use at least the same standard of care to protect Confidential Information it receives as it uses to protect its own Confidential Information from unauthorized disclosure, publication or dissemination. A Party may use Confidential Information solely to fulfill its obligations to the other Parties under this Agreement or its regulatory requirements.
- 22.1.7 Disclosure Required by Law or Order.** If a court or a Government Authority or entity with the right, power, and apparent authority to do so requests or requires a Party, by subpoena, oral deposition, interrogatories, requests for production of documents, administrative order, or otherwise, to disclose Confidential Information, that Party shall provide the other Parties with prompt notice of such request(s) or requirement(s) so that the other Parties may seek an appropriate protective order or waive compliance with the terms of this Agreement. Notwithstanding the absence of a protective order or waiver, the Party may disclose such Confidential Information which, in the opinion of its counsel, the Party is legally compelled to disclose, including any Confidential Information that, in the opinion of IID's counsel, IID is legally compelled to disclose under California public record laws. A Party will use Reasonable Efforts to obtain reliable assurance that confidential treatment will be accorded any Confidential Information so furnished.

- 22.1.8 Termination of Agreement.** Upon termination of this Agreement for any reason, each Party shall, within ten (10) Calendar Days of receipt of a written request from another Party, use Reasonable Efforts to destroy, erase, or delete (with such destruction, erasure, and deletion certified in writing to the other Parties) or return to another Party, without retaining copies thereof, any and all written or electronic Confidential Information received from the other Party.
- 22.1.9 Remedies.** The Parties agree that monetary damages would be inadequate to compensate a Party for another Party's Breach of its obligations under this Article 22. Each Party accordingly agrees that the other Parties shall be entitled to equitable relief, by way of injunction or otherwise, if the first Party Breaches or threatens to Breach its obligations under this Article 22, which equitable relief shall be granted without bond or proof of damages, and the receiving Party shall not plead in defense that there would be an adequate remedy at law. Such remedy shall not be deemed an exclusive remedy for the Breach of this Article 22, but shall be in addition to all other remedies available at law or in equity. The Parties further acknowledge and agree that the covenants contained herein are necessary for the protection of legitimate business interests and are reasonable in scope. No Party, however, shall be liable for indirect, incidental, or consequential or punitive damages of any nature or kind resulting from or arising in connection with this Article 22.
- 22.1.10 Disclosure to FERC, its Staff, or a State.** Notwithstanding anything in this Article 22 to the contrary, and pursuant to 18 CFR section 1b.20, if FERC or its staff, during the course of an investigation or otherwise, requests information from one of the Parties that is otherwise required to be maintained in confidence pursuant to this Agreement, the Party shall provide the requested information to FERC or its staff, within the time provided for in the request for information. In providing the information to FERC or its staff, the Party must, consistent with 18 CFR section 388.112, request that the information be treated as confidential and non-public by FERC and its staff and that the information be withheld from public disclosure. Parties are prohibited from notifying the other Party to this Agreement prior to the release of the Confidential Information to FERC or its staff. The Party shall notify the other Parties to the Agreement when it is notified by FERC or its staff that a request to release Confidential Information has been received by FERC, at which time any of the Parties may respond before such information would be made public, pursuant to 18 CFR section 388.112. Requests from a state regulatory body conducting a confidential investigation shall be treated in a similar manner if consistent with the applicable state rules and regulations.
- 22.1.11** Subject to the exception in Article 22.1.10, Confidential Information shall not be disclosed by the other Parties to any person not employed or retained by the other Parties, except to the extent disclosure is (i) required by law; (ii) reasonably deemed by the disclosing Party to be required to be disclosed in connection with a dispute between or among the Parties, or the defense of litigation or dispute; (iii) otherwise permitted by consent of the other Parties, such consent not to be unreasonably withheld; or (iv) necessary to fulfill its obligations under this Agreement or as a transmission service provider or a Balancing Authority

including disclosing the Confidential Information to an RTO or ISO or to a regional or national reliability organization. The Party asserting confidentiality shall notify the other Party in writing of the information it claims is confidential. Prior to any disclosures of another Party's Confidential Information under this subparagraph, or if any third party or Governmental Authority makes any request or demand for any of the information described in this subparagraph, the disclosing Party agrees to promptly notify the other Party in writing and agrees to assert confidentiality and cooperate with the other Party in seeking to protect the Confidential Information from public disclosure by confidentiality agreement, protective order or other reasonable measures.

Article 23. Environmental Releases

23.1 Each Party shall notify the other Parties, first orally and then in writing, of the release of any Hazardous Substances, any asbestos or lead abatement activities, or any type of remediation activities related to the Large Generating Facility or the Interconnection Facilities, each of which may reasonably be expected to affect the other Party. The notifying Party shall: (i) provide the notice as soon as practicable, provided such Parties makes a good faith effort to provide the notice no later than twenty-four hours after such Party becomes aware of the occurrence; and (ii) promptly furnish to the other Parties copies of any publicly available reports filed with any Governmental Authorities addressing such events.

Article 24. Information Requirements

24.1 Information Acquisition. APS, on behalf of Transmission Owners, and Interconnection Customer shall submit specific information regarding the electrical characteristics of their respective facilities to each other as described below and in accordance with Applicable Reliability Standards.

24.2 Information Submission by APS, on behalf of Transmission Owners. The initial information submission by APS, on behalf of Transmission Owners, shall occur no later than one hundred eighty (180) Calendar Days prior to Trial Operation of a Project Phase and shall include Transmission System information necessary to allow Interconnection Customer to select equipment and meet any system protection and stability requirements, unless otherwise agreed to by the Parties. On a monthly basis APS, on behalf of Transmission Owners, shall provide Interconnection Customer and the CAISO a status report on the construction and installation of Transmission Owners' Interconnection Facilities and Network Upgrades, including, but not limited to, the following information: (1) progress to date; (2) a description of the activities since the last report (3) a description of the action items for the next period; and (4) the delivery status of equipment ordered.

24.3 Updated Information Submission by Interconnection Customer. The updated information submission by Interconnection Customer, including manufacturer information, shall occur no later than one hundred eighty (180) Calendar Days prior to the Trial Operation of a Project Phase. Interconnection Customer shall submit a completed copy of the Large Generating Facility data requirements contained in Appendix 1 to the LGIP. It shall also include any additional updates to information provided to APS and CAISO for the Interconnection Feasibility, Interconnection

Facilities Study, and the CAISO Phase II Interconnection Study, as applicable. Information in this submission shall be the most current Large Generating Facility design or expected performance data. Information submitted for stability models shall be compatible with APS's and the CAISO's standard models. If there is no compatible model, Interconnection Customer will work with a consultant mutually agreed to by the Parties to develop and supply a standard model and associated information.

If Interconnection Customer's data is materially different from what was originally provided to APS or the CAISO pursuant to the Interconnection Study Agreements between APS or the CAISO and Interconnection Customer, then APS or the CAISO, as applicable, will conduct appropriate studies to determine the impact on the Transmission System based on the actual data submitted pursuant to this Article 24.3. The Interconnection Customer shall not begin Trial Operation of a Project Phase until such studies are completed and all other applicable requirements of this Agreement are satisfied.

If Interconnection Customer's data is materially different from what was originally provided to IID by the CAISO or by the Interconnection Customer pursuant to the Affected System Study Agreement, then IID also shall have the right, but not the obligation, to conduct any appropriate Affected System Study necessary to determine the impact on its non-JPP transmission facilities based on the actual data submitted pursuant to this Article 24.3. To the extent IID exercises this right, Interconnection Customer shall not begin Trial Operation of a Project Phase until such studies are completed and all other applicable requirements of this Agreement are satisfied.

24.4 Information Supplementation. Prior to Trial Operation of a Project Phase, the Parties shall supplement their information submissions described above in this Article 24 with any and all "as-built" Large Generating Facility information or "as-tested" performance information that differs from the initial submissions or, alternatively, written confirmation that no such differences exist. The Interconnection Customer shall conduct tests on the Large Generating Facility as required by Good Utility Practice such as an open circuit "step voltage" test on the Large Generating Facility to verify proper operation of the Large Generating Facility's automatic voltage regulator.

Unless otherwise agreed, the test conditions shall include: (1) Large Generating Facility at synchronous speed; (2) automatic voltage regulator on and in voltage control mode; and (3) a five percent change in Large Generating Facility terminal voltage initiated by a change in the voltage regulators reference voltage. Interconnection Customer shall provide validated test recordings showing the responses of Large Generating Facility terminal and field voltages. In the event that direct recordings of these voltages is impractical, recordings of other voltages or currents that mirror the response of the Large Generating Facility's terminal or field voltage are acceptable if information necessary to translate these alternate quantities to actual Large Generating Facility terminal or field voltages is provided. Large Generating Facility testing shall be conducted and results provided to APS and the CAISO at the request of APS and the CAISO.

Subsequent to the Commercial Operation Date for a Project Phase, Interconnection Customer shall provide APS and the CAISO any information changes due to equipment replacement, repair, or adjustment. APS, on behalf of Transmission Owners, shall provide Interconnection Customer any information changes due to equipment

replacement, repair or adjustment in the directly connected substation or any adjacent Transmission Owners' substation that may affect Interconnection Customer's Interconnection Facilities equipment ratings, protection or operating requirements. The Parties shall provide such information pursuant to Article 5.19.

Article 25. Information Access and Audit Rights

- 25.1 Information Access.** Each Party (the "disclosing Party") shall make available to the other Parties information that is in the possession of the disclosing Party and is necessary in order for the other Parties to: (i) verify the costs incurred by the disclosing Party for which another Party is responsible under this Agreement; and (ii) carry out its obligations and responsibilities under this Agreement. The Parties shall not use such information for purposes other than those set forth in this Article 25.1 and to enforce their rights under this Agreement. Nothing in this Article 25 shall obligate a Party to make available to another Party any third party information in its possession or control if making such third party information available would violate a Tariff or other legal restriction on the use or disclosure of such third party information.
- 25.2 Reporting of Non-Force Majeure Events.** Each Party (the "notifying Party") shall notify the other Parties when the notifying Party becomes aware of its inability to comply with the provisions of this Agreement for a reason other than a Force Majeure event. The Parties agree to cooperate with each other and provide necessary information regarding such inability to comply, including the date, duration, reason for the inability to comply, and corrective actions taken or planned to be taken with respect to such inability to comply. Notwithstanding the foregoing, notification, cooperation or information provided under this article shall not entitle the Parties receiving such notification to allege a cause for anticipatory breach of this Agreement.
- 25.3 Audit Rights.** Subject to the requirements of confidentiality under Article 22 of this Agreement, each Party shall have the right, during normal business hours, and upon prior reasonable notice to the other Party, to audit at its own expense the other Party's accounts and records pertaining to either such Party's performance or either such Party's satisfaction of obligations under this Agreement. Such audit rights shall include audits of the other Party's costs pertaining to such Party's performance or satisfaction of obligations owned to the other Party under this Agreement, calculation of invoiced amounts, APS's and the CAISO's efforts to allocate responsibility for the provision of reactive support to the Transmission System, Transmission Owners' and the CAISO's efforts to allocate responsibility for interruption or reduction of generation on the Transmission System, and each Party's actions in an Emergency Condition. Any audit authorized by this article shall be performed at the offices where such accounts and records are maintained and shall be limited to those portions of such accounts and records that relate to each such Party's performance and satisfaction of obligations under this Agreement. Each such Party shall keep such accounts and records for a period equivalent to the audit rights periods described in Article 25.4. Notwithstanding anything to the contrary in Article 25, each Party's rights to audit APS's, IID's, SDG&E's or the CAISO's accounts and records shall be subject to their respective Tariffs.
- 25.4 Audit Rights Periods.**

25.4.1 Audit Rights Period for Construction-Related Accounts and Records. Accounts and records related to the design, engineering, procurement, and construction of Transmission Owners' Interconnection Facilities and Network Upgrades shall be subject to audit for a period of twenty-four months following issuances of final invoices in accordance with Article 12.2.

25.4.2 Audit Rights Period for All Other Accounts and Records. Accounts and records related to either Party's performance or satisfaction of all obligations under this Agreement other than those described in Article 25.4.1 shall be subject to audit as follows: (i) for an audit relating to cost obligations, the applicable audit rights period shall be twenty-four months after the auditing Party's receipt of an invoice giving rise to such cost obligations; and (ii) for an audit relating to all other obligations, the applicable audit rights period shall be twenty-four months after the event for which the audit is sought.

25.5 Audit Results. If an audit by a Party determines that an overpayment or an underpayment has occurred, a notice of such overpayment or underpayment shall be given to the other Parties together with those records from the audit which support such determination.

Article 26. Subcontractors

26.1 General. Nothing in this Agreement shall prevent a Party from utilizing the services of any subcontractor as it deems appropriate to perform its obligations under this Agreement; provided, however, that each Party shall require its subcontractors to comply with all applicable terms and conditions of this Agreement in providing such services and each Party shall remain primarily liable to the other Party for the performance of such subcontractor.

26.2 Responsibility of Principal. The creation of any subcontract relationship shall not relieve the hiring Party of any of its obligations under this Agreement. The hiring Party shall be fully responsible to the other Parties for the acts or omissions of any subcontractor the hiring Party hires as if no subcontract had been made; provided, however, that in no event shall Transmission Owners or the CAISO be liable for the actions or inactions of Interconnection Customer or its subcontractors with respect to obligations of Interconnection Customer under Article 5 of this Agreement. Any applicable obligation imposed by this Agreement upon the hiring Party shall be equally binding upon, and shall be construed as having application to, any subcontractor of such Party.

26.3 No Limitation by Insurance. The obligations under this Article 26 will not be limited in any way by any limitation of subcontractor's insurance.

Article 27. Disputes

Disputes between the Interconnection Customer, CAISO and/or SDG&E arising out of requirements of the CAISO Tariff shall be settled in accordance with the provisions of Article 13 of the CAISO Tariff, except that references to the CAISO Tariff in such Article 13 of the CAISO Tariff shall be read as references to this Agreement. Disputes between the Interconnection

Customer and IID arising out of the Affected System Study Agreement or Affected System Construction and Operation Agreement shall be resolved in accordance with the provisions of Section 13.5 of the Generation Interconnection Procedures in IID's Tariff. All other disputes shall be resolved as follows:

27.1 Submission. In the event a Party has a dispute, or asserts a claim, that arises out of or in connection with this Agreement or its performance, such Party (the "disputing Party") shall provide the other Parties with written notice of the dispute or claim ("Notice of Dispute"). Such dispute or claim shall be referred to a designated senior representative of each Party for resolution on an informal basis as promptly as practicable after receipt of the Notice of Dispute by the other Parties. In the event the designated representatives are unable to resolve the claim or dispute through unassisted or assisted negotiations within thirty (30) Calendar Days of the other Parties' receipt of the Notice of Dispute, such claim or dispute may, upon mutual agreement of the Parties, be submitted to arbitration and resolved in accordance with the arbitration procedures set forth below. In the event the Parties do not agree to submit such claim or dispute to arbitration, any Party may exercise whatever rights and remedies it may have in equity or at law consistent with the terms of this Agreement.

27.2 External Arbitration Procedures. Any arbitration initiated under this Agreement shall be conducted before a single neutral arbitrator appointed by the Parties, or in the absence of such appointment, by selection by the American Arbitration Association. The arbitrator shall be knowledgeable in electric utility matters, including electric transmission and bulk power issues, and shall not have any current or past substantial business or financial relationships with any party to the arbitration (except prior arbitration). The arbitrator shall provide each of the Parties an opportunity to be heard and, except as otherwise provided herein, shall conduct the arbitration in accordance with the Commercial Arbitration Rules of the American Arbitration Association ("Arbitration Rules") and any applicable FERC regulations; provided, however, in the event of a conflict between the Arbitration Rules and the terms of this Article 27, the terms of this Article 27 shall prevail.

27.3 Arbitration Decisions. Unless otherwise agreed by the Parties, the arbitrator shall render a decision within ninety (90) Calendar Days of appointment and shall notify the Parties in writing of such decision and the reasons therefor. The arbitrator shall be authorized only to interpret and apply the provisions of this Agreement and shall have no power to modify or change any provision of this Agreement in any manner. The decision of the arbitrator shall be final and binding upon the Parties, and judgment on the award may be entered in any court having jurisdiction. The decision of the arbitrator may be appealed solely on the grounds that the conduct of the arbitrator, or the decision itself, violated the standards set forth in the Federal Arbitration Act or the Administrative Dispute Resolution Act. The final decision of the arbitrator must also be filed with FERC if it affects jurisdictional rates, terms and conditions of service, Interconnection Facilities, or Network Upgrades.

27.4 Costs. Each Party shall be responsible for its own costs incurred during the arbitration process and for its per capita share of the cost of the arbitrator.

Article 28. Representations, Warranties, and Covenants

28.1 General. Each Party makes the following representations, warranties and covenants:

28.1.1 Good Standing. Such Party is duly organized, validly existing and in good standing under the laws of the state in which it is organized, formed, or incorporated, as applicable; that it is qualified to do business in the state or states in which the Large Generating Facility, Interconnection Facilities and Network Upgrades owned by such Party, as applicable, are located; and that it has the corporate power and authority to own its properties, to carry on its business as now being conducted and to enter into this Agreement and carry out the transactions contemplated hereby and perform and carry out all covenants and obligations on its part to be performed under and pursuant to this Agreement.

28.1.2 Authority. Such Party has the right, power and authority to enter into this Agreement, to become a Party hereto and to perform its obligations hereunder. This Agreement is a legal, valid and binding obligation of such Party, enforceable against such Party in accordance with its terms, except as the enforceability thereof may be limited by applicable bankruptcy, insolvency, reorganization or other similar laws affecting creditors' rights generally and by general equitable principles (regardless of whether enforceability is sought in a proceeding in equity or at law).

28.1.3 No Conflict. The execution, delivery and performance of this Agreement does not violate or conflict with the organizational or formation documents, or bylaws or operating agreement, of such Party, or any judgment, license, permit, order, material agreement or instrument applicable to or binding upon such Party or any of its assets.

28.1.4 Consent and Approval. Such Party has sought or obtained, or, in accordance with this Agreement will seek or obtain, each consent, approval, authorization, order, or acceptance by any Governmental Authority in connection with the execution, delivery and performance of this Agreement, and it will provide to any Governmental Authority notice of any actions under this Agreement that are required by Applicable Laws and Regulations.

Article 29. Joint Operating Committee

29.1 Joint Operating Committee. APS, on behalf of the Transmission Owners, shall constitute a Joint Operating Committee to coordinate operating and technical considerations of Interconnection Service. At least six (6) months prior to the expected Initial Synchronization Date, APS and Interconnection Customer shall appoint one representative and one alternate to the Joint Operating Committee. APS and Interconnection Customer shall notify each other of its appointment in writing. Such appointments may be changed at any time by similar notice. The Joint Operating Committee shall meet as necessary, but not less than once each calendar year, to carry out the duties set forth herein. The Joint Operating Committee shall hold a meeting at the request of any Party, at a time and place agreed upon by the representatives of the Joint Operating Committee. The Joint Operating Committee shall perform all of its duties consistent with the provisions of this Agreement. Each Party shall cooperate in providing to the Joint Operating Committee all information required in the performance of the Joint Operating Committee's duties. All decisions and agreements, if any, made by the Joint

Operating Committee, shall be evidenced in writing. The duties of the Joint Operating Committee shall include the following:

- 29.1.1** Establish data requirements and operating record requirements.
- 29.1.2** Review the requirements, standards, and procedures for data acquisition equipment, protective equipment, and any other equipment or software.
- 29.1.3** Annually review the one (1) year forecast of maintenance and planned outage schedules of Transmission Owners' and Interconnection Customer's facilities at the Point of Interconnection.
- 29.1.4** Coordinate the scheduling of maintenance and planned outages on the Interconnection Facilities, the Large Generating Facility and other facilities that impact the normal operation of the interconnection of the Large Generating Facility to the Transmission System.
- 29.1.5** Ensure that information is being provided by each Party regarding equipment availability.
- 29.1.6** Perform such other duties as may be conferred upon it by mutual agreement of the Parties.

Article 30. Miscellaneous

- 30.1 Binding Effect.** This Agreement and the rights and obligations hereof, shall be binding upon and shall inure to the benefit of the successors and assigns of the Parties hereto.
- 30.2 Conflicts.** In the event of a conflict between the body of this Agreement and any attachment, appendices or exhibits hereto, the terms and provisions of the body of this Agreement shall prevail and be deemed the final intent of the Parties.
- 30.3 Rules of Interpretation.** This Agreement, unless a clear contrary intention appears, shall be construed and interpreted as follows: (1) the singular number includes the plural number and vice versa; (2) reference to any person includes such person's successors and assigns but, in the case of a Party, only if such successors and assigns are permitted by this Agreement, and reference to a person in a particular capacity excludes such person in any other capacity or individually; (3) reference to any agreement (including this Agreement), document, instrument or tariff means such agreement, document, instrument, or tariff as amended or modified and in effect from time to time in accordance with the terms thereof and, if applicable, the terms hereof; (4) reference to any Applicable Laws and Regulations means such Applicable Laws and Regulations as amended, modified, codified, or reenacted, in whole or in part, and in effect from time to time, including, if applicable, rules and regulations promulgated thereunder; (5) unless expressly stated otherwise, reference to any Article, Section or Appendix means such Article of this Agreement or such Appendix to this Agreement, or such Section to the applicable Large Generator Interconnection Procedures or such Appendix to the applicable Large Generator Interconnection Procedures, as the case may be; (6) "hereunder", "hereof", "herein", "hereto" and words of similar import shall be deemed references to this Agreement as a whole and not to any particular Article or other

provision hereof or thereof; (7) "including" (and with correlative meaning "include") means including without limiting the generality of any description preceding such term; and (8) relative to the determination of any period of time, "from" means "from and including", "to" means "to but excluding" and "through" means "through and including".

30.4 Entire Agreement. This Agreement, including all Appendices and Schedules attached hereto, constitutes the entire agreement among all of the Parties with reference to the subject matter hereof, and supersedes all prior and contemporaneous understandings or agreements, oral or written, among the Parties with respect to the subject matter of this Agreement. There are no other agreements (other than the Affected System Study Agreement and Affected System Construction and Operation Agreement), representations, warranties, or covenants which constitute any part of the consideration for, or any condition to, any Party's compliance with its obligations under this Agreement.

30.5 No Third Party Beneficiaries. This Agreement is not intended to and does not create rights, remedies, or benefits of any character whatsoever in favor of any persons, corporations, associations, or entities other than the Parties, and the obligations herein assumed are solely for the use and benefit of the Parties, their successors in interest and, where permitted, their assigns.

30.6 Waiver. The failure of a Party to this Agreement to insist, on any occasion, upon strict performance of any provision of this Agreement will not be considered a waiver of any obligation, right, or duty of, or imposed upon, such Party.

Any waiver at any time by either Party of its rights with respect to this Agreement shall not be deemed a continuing waiver or a waiver with respect to any other failure to comply with any other obligation, right, duty of this Agreement. Termination or Default of this Agreement for any reason by Interconnection Customer shall not constitute a waiver of Interconnection Customer's legal rights to obtain an interconnection from Transmission Owner. Any waiver of this Agreement shall, if requested, be provided in writing.

30.7 Headings. The descriptive headings of the various Articles of this Agreement have been inserted for convenience of reference only and are of no significance in the interpretation or construction of this Agreement.

30.8 Multiple Counterparts. This Agreement may be executed in two or more counterparts, each of which is deemed an original but all constitute one and the same instrument.

30.9 Amendment. The Parties may by mutual agreement amend this Agreement by a written instrument duly executed by all the Parties. Such amendment shall become effective and a part of this Agreement upon satisfaction of all Applicable Laws and Regulations.

30.10 Modification by the Parties. The Parties may by mutual agreement amend the Appendices to this Agreement by a written instrument duly executed by the Parties. Such amendment shall become effective and a part of this Agreement upon satisfaction of all Applicable Laws and Regulations.

- 30.11 Reservation of Rights.** FERC-jurisdictional Transmission Owners and the CAISO shall have the right to make a unilateral filing with FERC to modify this Agreement with respect to any rates, terms and conditions, charges, classifications of service, rule or regulation under section 205 or any other applicable provision of the Federal Power Act and FERC's rules and regulations thereunder, and Interconnection Customer shall have the right to make a unilateral filing with FERC to modify this Agreement pursuant to section 206 or any other applicable provision of the Federal Power Act and FERC's rules and regulations thereunder; provided that another Party shall have the right to protest any such filing by the other Party and to participate fully in any proceeding before FERC in which such modifications may be considered. Nothing in this Agreement shall limit the rights of the Parties or of FERC under sections 205 or 206 of the Federal Power Act and FERC's rules and regulations thereunder, except to the extent that the Parties otherwise mutually agree as provided herein. Notwithstanding the foregoing, IID shall not be subject, without its mutual consent, to a modification of its rights and obligations under this Agreement through a unilateral filing by another Party with FERC and, as applied to IID, the Effective Date of a modified Agreement shall not commence until the modified Agreement is actually executed by IID, either voluntarily or pursuant to a lawful order issued by FERC in accordance with Sections 210 and 212 of the Federal Power Act.
- 30.12 No Partnership.** This Agreement shall not be interpreted or construed to create an association, joint venture, agency relationship, or partnership among the Parties or to impose any partnership obligation or partnership liability upon any Party. No Party shall have any right, power or authority to enter into any agreement or undertaking for, or act on behalf of, or to act as or be an agent or representative of, or to otherwise bind, another Party.
- 30.13 Joint and Several Obligations.** Except as otherwise provided in this Agreement, the obligations of each Transmission Owner, the CAISO and the Interconnection Customer are several, and are neither joint nor joint and several.

[REMAINDER OF PAGE INTENTIONALLY LEFT BLANK]

IN WITNESS WHEREOF, the Parties have executed this Agreement in multiple originals, each of which shall constitute and be an original effective Agreement among the Parties.

Arizona Public Service Company

By: J. R. Lucas

Name: JOHN R. LUCAS

Title: MANAGER

Date: 5/27/10

Imperial Irrigation District

By: _____

Name: _____

Title: _____

Date: _____

San Diego Gas & Electric Company

By: _____

Name: _____

Title: _____

Date: _____

California Independent System Operator Corporation

By: _____

Name: _____

Title: _____

Date: _____

Agua Caliente Solar, LLC

By: _____

Name: _____

Title: _____

Date: _____

North Gila River Development, LLC

By: _____

Name: _____

Title: _____

Date: _____

IN WITNESS WHEREOF, the Parties have executed this Agreement in multiple originals, each of which shall constitute and be an original effective Agreement among the Parties.

Arizona Public Service Company

By: _____
Name: _____
Title: _____
Date: _____

Imperial Irrigation District

By: _____
Name: _____
Title: _____
Date: _____

San Diego Gas & Electric Company

By: _____
Name: _____
Title: _____
Date: _____

California Independent System Operator Corporation

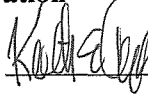
By:  _____
Name: _____
Title: KEITH E. CASEY PH.D. VICE PRESIDENT
MARKET & INFRASTRUCTURE DEVELOPMENT
Date: 5/19/10

Agua Caliente Solar, LLC

By: _____
Name: _____
Title: _____
Date: _____

North Gila River Development, LLC

By: _____
Name: _____
Title: _____
Date: _____

IN WITNESS WHEREOF, the Parties have executed this Agreement in multiple originals, each of which shall constitute and be an original effective Agreement among the Parties.

Arizona Public Service Company

By: _____
Name: _____
Title: _____
Date: _____

Imperial Irrigation District

By: _____
Name: _____
Title: _____
Date: _____

San Diego Gas & Electric Company

By: _____
Name: _____
Title: _____
Date: _____

California Independent System Operator Corporation

By: _____
Name: _____
Title: _____
Date: _____

Agua Caliente Solar, LLC

By: Frank De Rosa
Name: Frank De Rosa
Title: President
Date: May 27, 2010

North Gila River Development, LLC

By: Frank De Rosa
Name: Frank De Rosa
Title: President
Date: May 27, 2010

Appendices

Appendix A-1

Interconnection Facilities, JPP Network Upgrades, and Distribution Upgrades for Phase A of the Interconnection Project

The Generating Facility will have a total rated capacity of 500 MW based on both Phase A and Phase B achieving Commercial Operation. This Appendix A-1 addresses Phase A of the Generating Facility and Appendix A-2 addresses Phase B of the Generating Facility.

1. Phase A of the Generating Facility Description:

Phase A of the Generating Facility is located on private land and consists of a photovoltaic solar field, inverters, a medium voltage collection system, an operations and maintenance building, a 34.5kV/500kV substation and various other facilities. Phase A of the Generating Facility will consist of no more than 290 MW (net) of solar photovoltaic units installed at the site.

The Interconnection Customer Interconnection Facilities include a new substation which will contain two (2) 34.5kV/500kV step-up transformers (“SUTs”). The SUTs are combined through a common high voltage bus that is connected to one single 500 kV interconnection line. Phase A of the Generating Facility is connected to the Transmission Owners’ 500kV switchyard (“Switchyard”) via the single 500kV interconnection line. The substation is located in close proximity to the Switchyard.

2. Point of Interconnection:

The Point of Interconnection for Phase A of the Generating Facility is the Switchyard. See Appendix C – Diagram.

3. Power Injection Limitation at the Point of Interconnection:

The maximum allowable injection of power into the Switchyard at the Point of Interconnection for Phase A of the Generating Facility shall be 290 MW.

4. Point of Change of Ownership:

The Point of Change of Ownership demarcation point of the high voltage conductors and static wires will be the first designed dead end structure outside of the Switchyard fence. The Point of Change of Ownership will be at the line jumper connection point on the Transmission Owners’ dead-ended conductor. Interconnection Customer will provide, per APS specifications, required materials, including foundations, steel structures, insulators, attachment hardware and dead-end connectors to install and terminate conductors at this structure from Switchyard. APS will supply and install conductors to this point of attachment. Interconnection Customer will provide and install materials, including insulators, attachment hardware, conductors, dead-end connectors, and jumper connections, from the Generating Facility substation to the termination point on the dead end structure. See Appendix C – Diagram.

If overhead communication cable is utilized, the interconnection and ownership demarcation point will be a splice point located on the first designed dead-end structure for the high voltage conductor outside of the Switchyard fence. Interconnection Customer will provide required materials for attachment of cable to structures to this point from the Switchyard. APS will provide communication cable to this point. Interconnection Customer will be responsible for providing materials and connection to APS termination at this location.

If underground communication cable is utilized, the interconnection and ownership demarcation point will be a manhole located outside of the Switchyard fence. APS will provide manhole and other materials required to install cable from the Switchyard. Interconnection Customer will be responsible for providing materials and connection to APS termination at this location.

5. Interconnection Facilities:

(a) Interconnection Customer's Interconnection Facilities

The Interconnection Customer's Interconnection Facilities consists of a 34.5/500kV Generating Facility substation, support structures, including the two sided dead end structure, and a generation tie line from the Generating Facility substation to the Point of Change of Ownership with the Transmission Owner's Interconnection Facilities. The Interconnection Customer's Interconnection Facilities also includes all metering equipment required to comply with the CAISO Tariff.

The following is an equipment list from the Interconnection Customer's Interconnection Facilities:

2 – 34.5kV/500kV step up transformers
Revenue meter
Shunt capacitors
Transmission structure at ownership change

(b) Transmission Owners' Interconnection Facilities

The Transmission Owners' Interconnection Facilities consist of the facilities between the Point of Change of Ownership and Point of Interconnection in the Switchyard. This consists of one 500 kV disconnect switch, and a span of 500kV conductor. The protection equipment for Phase A of the Interconnection Project is also included in Transmission Owners' Interconnection Facilities as is the metering equipment for the interconnection.

The following is an equipment list comprising the Transmission Owners' Interconnection Facilities:

Intertie meter
1 500kV, 3000A, Vertical Break Switch
Conductor
Relays

6. JPP Network Upgrades:

(a) Switchyard

APS will design and construct the new 500kV Switchyard. The Switchyard will be designed as a breaker-and-a-half configuration to accommodate future plans of the Transmission Owners and

potential future third-party generation developers. Initially, three 500kV breakers and supporting bus work and structures will be built to accommodate the line terminations from (i) Hassayampa, (ii) North Gila and (iii) the Generating Facility. This initial phase of the Switchyard will include 500kV bus work and disconnect switches to limit outages for future installations.

The Switchyard will also include a control enclosure for the housing of the critical protective relaying and the Supervisory Control and Data Acquisition (SCADA) system. The control room building will include sufficient battery capacity to reliably operate the Switchyard as part of the interconnected Transmission System. Redundant communication will be provided by a new 100-foot microwave tower constructed to support sufficient dishes and antenna to provide reliable integration of the Generating Facility into the APS communications network. No fiber optic lines are planned for Phase A of the Interconnection Project.

The Switchyard site will be secured with a minimum 7-foot tall, chain link metal-fabric security fence with 1-foot barbed wire or razor wire on top.

The following is an equipment list from the Switchyard portion of the JPP Network Upgrades:

Breakers - 3 500kV, 3000A, 63kA

Switches - 10 500kV, 3000A, Vertical Break

1 500kV 3000A, Vertical Reach

Current Transformers (CTs) - 3 500kV, Extended Range Metering Accuracy 1500/5A

CC Voltage Transformers (11)

A fourth breaker will be required when the Switchyard is converted from a ring bus alignment to a breaker and one half arrangement. The timing for this change will be driven by a fifth termination into the Switchyard.

(b) Transmission Line

The transmission interconnection will be a loop-in of the Switchyard to the existing Hassayampa – North Gila #1 500 kV line with the end points being new turning structures located within the existing 500kV line rights-of-way and the dead-end structures located within the Switchyard.

The following is an equipment/material list from the transmission line portion of the JPP Network Upgrades:

2 500kV Lattice Tower structures

Conductor

7. Stand-Alone JPP Network Upgrades: None

8. Transmission Owners' Interconnection Facilities and JPP Network Upgrade Cost Summary:

Cost Estimate (2010 dollars)

Element	Cost	Transmission Owner Share		
		APS	IID	SDG&E
Transmission Owners' Interconnection Facilities				
500kV conductor tie line	611,000	0	0	0
Disconnect Switches	150,000	0	0	0
Protection Equipment	400,000	0	0	0
Contingency	232,000	0	0	0
1) Subtotal	1,393,000	0	0	0
JPP Network Upgrades				
Transmission	1,985,000	218,350	253,683	1,512,967
Switchyard	14,700,000	1,617,000	1,878,660	11,204,340
Telecommunications	75,000	8,250	9,585	57,165
Relay changes at Hassayampa	136,000	14,960	17,381	103,659
Relay changes at North Gila	136,000	14,960	17,381	103,659
Deferred breaker	810,000	89,100	103,518	617,382
Contingency	3,568,000	392,480	455,990	2,719,530
2) Subtotal JPP Network Upgrades	21,410,000	2,355,100	2,736,198	16,318,702
3) Interconnection Project Cost (for cash flow and financial security) (lines 1 & 2)	22,803,000	2,508,330	2,914,223	17,380,447
4) Interconnection Customer Contributions to Network Upgrades (real estate, environmental, and rough grading)	1,173,000	129,030	149,909	894,060
5) Total Network Upgrades (for reimbursement to Agua Caliente Solar, LLC) (lines 2 & 4)	22,583,000	2,484,130	2,886,107	17,212,763

9. Estimate of Monthly Incurred Costs for the Transmission Owners' Interconnection Facilities and JPP Network Upgrades:

An estimate of the monthly incurred costs is shown below.

Month	Estimated Cost by Month
Through April 2010	\$240,168
May 2010	\$0
June 2010	\$0
July 2010	\$486,924
August 2010	\$0
September 2010	\$0
October 2010	\$863,108
November 2010	\$863,108
December 2010	\$863,108
January 2011	\$5,305,720
February 2011	\$5,305,720
March 2011	\$5,305,720
April 2011	\$337,376
May 2011	\$337,376
June 2011	\$337,376
July 2011	\$348,120
August 2011	\$348,120
September 2011	\$348,120
October 2011	\$119,108
November 2011	\$119,108
December 2011	\$119,108
January 2012	\$1,155,672
Total	\$22,803,000

10. Invoicing and JPP Network Upgrade Repayment:

Invoices issued by APS on behalf of the Transmission Owners pursuant to Articles 12.1 and 12.2 of this Agreement for Phase A of the Generating Facility shall include the cumulative balance invoiced to date for the JPP Network Upgrades (including the actual costs for Network Upgrades incurred under the E&P Agreement) and the allocation of such balance to the Ownership Interests.

Within thirty (30) Calendar Days of the Commercial Operation Date for a Project Phase, APS, on behalf of the Transmission Owners, shall provide the Parties with a statement which indicates the

Ownership Share of each of the Transmission Owners in the cost of the Network Upgrades which are to be repaid in accordance with the provisions of Article 11.4.2 of this Agreement.

- (a) SDG&E Share: Interconnection Customer and SDG&E have agreed that SDG&E shall make the repayment provided for in Article 11.4.2 of this Agreement by making a cash payment to Agua Caliente Solar, LLC within sixty (60) Calendar Days of the Commercial Operation Date of each Project Phase.
- (b) APS Share: APS shall make the repayment provided for in Article 11.4.1 of this Agreement to Agua Caliente Solar, LLC in accordance with the terms of this Agreement.
- (c) IID Share: IID shall make the repayment provided for in Article 11.4.3 of this Agreement to Agua Caliente Solar, LLC in accordance with the terms of this Agreement.

11. Distribution Upgrades: NONE

12. Maintenance, Repair, and Replacement Charges:

The Interconnection Customer shall be responsible for actual costs incurred by APS, on behalf of the Transmission Owners, applicable to the maintenance, repair and replacement of the Transmission Owners' Interconnection Facilities, including but not limited to: the 500 kV disconnect switches, protection equipment for the Interconnection Customer's Interconnection Facilities, metering including CTs and PTs and communications equipment and all associated equipment (see Appendix C, Diagram). A good faith non-binding estimate of annual cost, for budgetary purposes only, is:

Estimate = \$ 1,000 per year

\$1,000 annually covers:

- Two inspections per year
- Relay maintenance (estimated at every 4-6 years)
- Disconnect switch maintenance (estimated at every 4-6 years)

Additional actual costs will be charged for:

- Emergency maintenance and repair work
- Replacement of failed or failing equipment

13. Transition from E&P Agreement:

The Parties recognize that some design and long lead-time procurement work for the interconnection of the Large Generating Facility to the JPP was done pursuant to the E&P Agreement entered into by APS, on behalf of the Transmission Owners, and the Interconnection Customer. In order to provide for a smooth transition between work done under the E&P Agreement and this Agreement, the Parties agree :

- (a) **Accounting Transition.** APS, on behalf of the Transmission Owners, shall calculate whether the Interconnection Customer has paid more or less than it owes under the terms of the E&P Agreement as of the Effective Date of this Agreement. If the Interconnection Customer paid more than it owes, APS, on behalf of the Transmission Owners, shall apply a credit to reduce the amount of the payments required under Article 12.1 of this Agreement for the Transmission Owners' Interconnection Facilities and JPP Network Upgrades. If the Interconnection Customer has paid less than it owes, the Interconnection Customer shall pay the amount due as if it were incurred for engineering and procurement work conducted pursuant to this Agreement, in

accordance with Article 12.1 of this Agreement, for the Transmission Owners' Interconnection Facilities and JPP Network Upgrades.

- (b) **Estimate of Total Interconnection Customer Payments.** In accordance with the Milestone Schedule in Appendix B-1, APS, on behalf of the Transmission Owners, shall provide an estimate of the total amount the Interconnection Customer paid under the E&P Agreement as of the Effective Date of this Agreement. This estimate shall be applied as a credit toward the amount of financial security due from the Interconnection Customer pursuant to Article 11.5 of this Agreement and Section 15 of this Appendix A-1 for the Transmission Owners' Interconnection Facilities and JPP Network Upgrades.
- (c) **Letter of Credit.** If the Interconnection Customer has posted a letter of credit or other financial security under the terms of the E&P Agreement, the letter of credit or other financial security shall be returned to Interconnection Customer as of the date the Interconnection Customer posts all of the financial security required in accordance with the terms of Article 11.5 of this Agreement and Section 14 of this Appendix A-1 for the Transmission Owners' Interconnection Facilities and JPP Network Upgrades.

14. Provision of Security:

- (a) **Initial Estimate of Financial Security to be Posted:** The amount available to be drawn under any credit support for the Transmission Owners' Interconnection Facilities and JPP Network Upgrades required to interconnect Phase A of the Generating Facility shall be:

APS Share (11.00%)	\$2,508,330
IID Share (12.78%)	\$2,914,223
Subtotal of APS and IID shares (23.78%)	\$5,422,553
SDG&E Share (76.22%)	\$17,380,447
TOTAL (100%)	\$22,803,000

- (b) **Adjustment for Amounts Paid under E&P Agreement:** The initial estimate of the financial security provided in Section 14(a) of this Appendix A-1 shall be reduced by each of the Transmission Owner's proportional shares of the estimated total Interconnection Customer payments made under the E&P Agreement. When APS, on behalf of the Transmission Owners, provides an estimate of the Interconnection Customer's total payments under the E&P Agreement pursuant to Section 13(b) of this Appendix A-1, it shall provide to the Interconnection Customer and the other Transmission Owners an adjusted estimate of the financial security to be posted.
- (c) **Posting:** The Interconnection Customer shall provide financial security for the Transmission Owners' Interconnection Facilities and JPP Network Upgrades no later than the milestone date specified in Appendix B-1 in accordance with Article 11.5 of this Agreement. With respect to the financial security for the APS and IID shares, Interconnection Customer shall post with APS, on behalf of APS and IID, the adjusted amount for both the APS and IID shares provided pursuant to Section 14(b) of this Appendix A-1 in the form of one security instrument.

With respect to the Interconnection Financial Security for SDG&E, SDG&E already holds Interconnection Financial Security for Phase A of the Generating Facility pursuant to the CAISO

Tariff. As of the date of signing of this Agreement, this security consists of two irrevocable letters of credit for the benefit of Agua Caliente Solar LLC. One of these letters, in the amount of \$5.8 million, has been posted to cover a portion of the Interconnection Customer's share of Network Upgrades. The other, in the amount of \$228,600 has been posted to cover a portion of the Transmission Owners' Interconnection Facilities. The letter of credit for the larger amount currently posted will terminate in accordance with its terms as of October 30, 2010, and the letter of credit for the smaller amount will terminate in accordance with its terms on October 30, 2010. Pursuant to the terms of the CAISO Tariff, these letters of credit must be replaced before they terminate; failure to do so shall provide grounds for termination of this Agreement as provided in Articles 2.3 and 11.5 of this Agreement.

It is possible that the amount of Interconnection Financial Security which the Interconnection Customer was previously required to post may be reduced by order of FERC as a result of litigation pending in Docket No. EL10-15. Regardless of any developments in that proceeding, Interconnection Customer will post the full amount of financial security as required by this Agreement for Phase A of the Generating Facility.

Under this Agreement the total amount the Interconnection Customer shall post no later than the milestone due date specified in Appendix B-1 shall be the adjusted amount for the SDG&E share provided pursuant to Section 14(b) of this Appendix A-1. If Interconnection Financial Security is to be provided before October 31, 2010, SDG&E agrees that the initial Interconnection Financial Security posted with SDG&E shall be replaced with new Interconnection Financial Security posted in accordance with the terms of this Agreement for the total adjusted amount for the SDG&E share provided pursuant to Section 14(b) of this Appendix A-1. SDG&E further agrees that it shall return the original Interconnection Financial Security and shall take no action to enforce its security rights, if any, under the existing Interconnection Financial Security once Interconnection Customer has posted new Interconnection Financial Security in accordance with the terms of this Agreement.

The Parties agree that the Interconnection Customer shall be allowed to make substitutions of the security posted under this Agreement so long as the new security posted is reasonably acceptable to the Transmission Owners, as provided for in Article 11.5 of this Agreement, and in the amount required by this Agreement.

- (d) Reduction of Amount of Security:** Interconnection Customer shall make arrangements for financial security that provide for periodic reduction of the amount of the financial security upon receipt of instructions from APS, acting on behalf of the Transmission Owners. APS, on behalf of the Transmission Owners, shall provide periodic notices of reductions in the amount of the financial security required to be held to the financial institution(s) the Interconnection Customer selects to hold the financial security. APS shall provide such notices to the financial institution holding the security for the APS and IID shares in accordance with the arrangements made by the Interconnection Customer with the financial institution(s), provided, however, that the procedures for providing notice are reasonably acceptable to APS. APS shall also provide notice to SDG&E and IID. Unless otherwise agreed by APS and the Interconnection Customer, APS shall provide notice monthly as payments are made in accordance with Article 12.1 and the financial security shall be reduced proportionately on a dollar-for-dollar by the payments made under this Agreement.

SDG&E agrees that within five (5) Calendar Days of receiving notice of a reduction in the amount of the security pursuant to this section, it shall inform the financial institution that holds the Interconnection Financial Security of the reduction in the amount of the security.

- (e) **Increases to Security Required Due to Change of Cost Estimates.** In the event that APS, on behalf of the Transmission Owners, finds that the cost estimate for Transmission Owner Interconnection Facilities and JPP Network Upgrades provided in this Appendix A-1 has increased, APS, on behalf of the Transmission Owners, shall have the option of (1) offsetting any reduction in the amount of security under Section 14(d) of this Appendix A-1 with the increase in the cost estimate, or (2) notifying Interconnection Customer of the required increase in its financial security to conform to the increased cost estimate.
- (f) **Enforcement of Security for Transmission Owners' Interconnection Facilities and JPP Network Upgrades:** In the event that this Agreement is terminated in accordance with Article 2.3 and APS, on behalf of Transmission Owners, is required to determine the cost responsibility of the Interconnection Customer in accordance with Article 2.4 for Transmission Owners' Interconnection Facilities and JPP Network Upgrades set forth in this Appendix A-1, the Parties agree that in addition to following the procedures set forth elsewhere in this Agreement, the Transmission Owners shall proceed as follows:
- (1) Subject to review and approval by all Transmission Owners, APS shall provide a statement indicating the total cost responsibility of the Interconnection Customer to all Transmission Owners and the allocation of this cost responsibility by Ownership Share ("Statement of Cost Responsibility"). This Statement of Cost Responsibility shall be accompanied by a detailed report which shows how the cost responsibility was determined, including information on all expenditures made on behalf of the Interconnection Customer, payments received, and bills outstanding.
 - (2) If the Interconnection Customer has cost responsibility, upon providing the Statement of Cost Responsibility and accompanying information, APS, on behalf of both APS and IID, shall enforce their financial security rights in proportion to the combined Ownership Interests of APS and IID.
 - (3) If the Interconnection Customer has cost responsibility, upon receipt of the Statement of Cost Responsibility and accompanying information, SDG&E shall enforce its financial security rights in proportion to the Ownership Interest of SDG&E. Within thirty Calendar Days of receipt of the Statement of Cost Responsibility, SDG&E shall provide the funds it receives by enforcing its financial security rights to APS.
 - (4) APS, acting on behalf of the Transmission Owners, shall use the funds provided by enforcing the financial security rights of the Transmission Owners to provide reimbursements and settle accounts proportionately in accordance with the Statement of Cost Responsibility and accompanying report.

15. Reporting Requirements:

Until the In-Service Date for the Transmission Owners' Interconnection Facilities and JPP Network Upgrades for Phase A of the Interconnection Project, Interconnection Customer and APS shall conduct a monthly meeting to coordinate the work related to the Transmission Owners' Interconnection Facilities and JPP Network Upgrades in this Appendix A-1. APS shall submit a monthly written report to the Interconnection Customer in advance of the meeting that provides the following information:

- (a) Progress report on activities;
- (b) Project schedule update; and
- (c) Spending report, including actual expenditures to date and forecasted expenditures in accordance with standard accounting practices.

16. Relationship of Agreement to CAISO Phase II Interconnection Study Report

The Parties acknowledge that this Appendix A-1 contains a list of Interconnection Facilities and JPP Network Upgrades and associated cost estimates that differs in some respects from the list of Interconnection Facilities and JPP Network Upgrades and associated cost estimates in the CAISO Phase II Interconnection Study report. The Parties agree to the descriptions of the Interconnection Facilities and JPP Network Upgrades and associated cost estimates in this Agreement notwithstanding any portions of the CAISO Phase II Interconnection Study report that are inconsistent with the terms of this Agreement; provided, however, that any impacts on, and upgrades required to, IID's Affected System (other than the JPP) shall be addressed in the Affected System Study Agreement and Affected System Construction and Operation Agreement to be executed between Interconnection Customer and IID. The Parties also agree that the cost estimates in this Agreement shall serve as the basis for the determination of the amounts of interconnection financial security required pursuant to Article 11.5, including the Interconnection Financial Security required pursuant to Section 9 of the CAISO's LGIP, rather than the cost estimates set forth in the Phase II Interconnection Study report.

Appendix A-2

Interconnection Facilities, JPP Network Upgrades, and Distribution Upgrades for Phase B of the Interconnection Project

The Generating Facility will have a total rated capacity of 500 MW based on both Phase A and Phase B achieving Commercial Operation. Appendix A-1 addresses Phase A of the Generating Facility and this Appendix A-2 addresses Phase B of the Generating Facility. If interconnection studies determined to be necessary pursuant to Section 4 of Appendix C show a need for additional Interconnection Facilities, JPP Network Upgrades, or Distribution Upgrades for Phase B of the Interconnection Project, this Agreement shall be amended in accordance with the provisions of Section 4 of Appendix C.

1. Phase B of the Generating Facility Description:

The Generating Facility consists of a photovoltaic solar field, inverters, a medium voltage collection system, an operations and maintenance building, and various other facilities. Phase B of the Generating Facility will consist of no more than 210 MW (net) of solar photovoltaic units.

The Interconnection Facilities associated with Phase B of the Generating Facility will include additional 34.5kV/500kV transformers and will be connected to the Switchyard via a single 500kV interconnection line separate from the Phase A 500kV interconnection line.

2. Point of Interconnection:

The Point of Interconnection for Phase B of the Generating Facility is the Switchyard. See Appendix C –Diagram.

3. Power Injection Limitation at the Point of Interconnection:

The maximum allowable injection of power into the Switchyard at the Point of Interconnection for Phase B of the Generating Facility shall be 210 MW.

4. Point of Change of Ownership:

The Point of Change of Ownership demarcation point of the high voltage conductors and static wires will be the first designed dead end structure outside of the Switchyard fence. The Point of Change of Ownership will be at the line jumper connection point on the Transmission Owners' dead-ended conductor. Interconnection Customer will provide, per APS specifications, required materials, including foundations, steel structures, insulators, attachment hardware and dead-end connectors to install and terminate conductors at this structure from Switchyard. APS will supply and install conductors to this point of attachment. Interconnection Customer will provide and install materials, including insulators, attachment hardware, conductors, dead-end connectors, and jumper connections, from the Generating Facility substation to the termination point on the dead end structure. See Appendix C – Diagram.

If overhead communication cable is utilized, the interconnection and ownership demarcation point will be a splice point located on the first designed dead-end structure for the high voltage conductor outside of the Switchyard fence. Interconnection Customer will provide required materials for attachment of cable to structures to this point from the Switchyard. APS will provide communication

cable to this point. Interconnection Customer will be responsible for providing materials and connection to APS termination at this location.

If underground communication cable is utilized, the interconnection and ownership demarcation point will be a manhole located outside of the Switchyard fence. APS will provide manhole and other materials required to install cable from the Switchyard. Interconnection Customer will be responsible for providing materials and connection to APS termination at this location.

5. Interconnection Facilities:

(a) Interconnection Customer's Interconnection Facilities.

The Interconnection Customer's Interconnection Facilities consist of additional 34.5/500 kV transformers and a generation tie line from the Generating Facility substation to the Point of Change of Ownership with the Transmission Owner's Interconnection Facilities. The Interconnection Customer's Interconnection Facilities also includes all metering equipment, if any, required for compliance with the CAISO Tariff.

The following is an equipment list from the Interconnection Customer's Interconnection Facilities:

34.5kV/500kV step up transformers
Revenue meter
Shunt capacitors
Transmission structure at ownership change

(b) Transmission Owners' Interconnection Facilities

The Transmission Owners' Interconnection Facilities consist of the facilities between the Point of Change of Ownership and Point of Interconnection in the Switchyard. This consists of one 500 kV disconnect switch, and a span of 500kV conductor. The protection equipment for Phase B of the Interconnection Project is also included in Transmission Owners' Interconnection Facilities as are the metering equipment for the interconnection.

The following is an equipment list from the Transmission Owners' Interconnection Facilities:

Intertie meter
3 500kV, 3000A, Vertical Break Switches
Conductor
Relays

6. JPP Network Upgrades:

APS will design and construct an additional line termination in the new 500kV Switchyard, which will be constructed for Phase A of the Interconnection Project.

The following is an equipment list from the Switchyard portion of the JPP Network Upgrades:

Breakers - 1 500kV, 3000A, 63kA
Switches - 2 500kV, 3000A, Vertical Break

A second breaker will be required when the Switchyard is converted from a ring bus alignment to a breaker and one half arrangement. The timing for this change will be driven by a fifth termination into the Switchyard.

7. Stand-Alone JPP Network Upgrades: None

8. Transmission Owners' Interconnection Facilities and JPP Network Upgrades Cost Summary:

Cost Estimate (2010 dollars)

Element	Cost	Transmission Owner Share		
		APS	IID	SDG&E
Transmission Owners' Interconnection Facilities				
500kV conductor tie line	657,000	0	0	0
Disconnect Switches	150,000	0	0	0
Protection Equipment	375,000	0	0	0
Contingency	236,000	0	0	0
1) Subtotal	1,418,000	0	0	0
JPP Network Upgrades				
Switchyard Breaker	899,000	98,890	114,852	685,218
Deferred breaker	810,000	89,100	103,518	617,382
Contingency	342,000	37,620	43,708	260,672
2) Subtotal	2,051,000	225,610	262,118	1,563,272
3) Total Interconnection Project Cost (for cash flow and financial security) (lines 1 & 2)	3,469,000	381,590	443,338	2,644,072
4) Total Network Upgrades (for reimbursement to North Gila River Development, LLC) (line 2)	2,051,000	225,610	262,118	1,563,272

9. Estimate of Monthly Incurred Costs for the Transmission Owners' Interconnection Facilities and JPP Network Upgrades:

An estimate of the monthly incurred costs is shown below.

Month	Estimated Cost by Month
Oct 2011	26,416
Nov 2011	26,416
Dec 2011	26,416

Jan 2012	609,160
Feb 2012	609,160
Mar 2012	609,160
April 2012	465,980
May 2012	465,980
June 2012	465,980
July 2012	47,180
Aug 2012	47,180
Sept 2012	47,180
Oct 2012	11,396
Nov 2012	11,396
Total	3,469,200

10. Invoicing and JPP Network Upgrade Repayment:

Invoices issued by APS on behalf of the Transmission Owner pursuant to Articles 12.1 and 12.2 of this Agreement for Phase B of the Generating Facility shall include the cumulative balance invoiced to date for the JPP Network Upgrades and the allocation of such balance to the Ownership Interests.

Within thirty (30) Calendar Days of the Commercial Operation Date for a Project Phase, APS, on behalf of the Transmission Owners, shall provide the Parties with a statement which indicates the Ownership Share of each of the Transmission Owners in the cost of the Network Upgrades which are to be repaid in accordance with the provisions of Article 11.4.2 of this Agreement.

- (a) SDG&E Share: Interconnection Customer and SDG&E have agreed that SDG&E shall make the repayment provided for in Article 11.4.2 of this Agreement by making a cash payment to North Gila River Development, LLC within sixty (60) Calendar Days of the Commercial Operation Date of each Project Phase.
- (b) APS Share: APS shall make the repayment provided for in Article 11.4.1 of this Agreement to North Gila River Development, LLC in accordance with the terms of this Agreement.
- (c) IID Share: IID shall make the repayment provided for in Article 11.4.3 of this Agreement to North Gila River Development, LLC in accordance with the terms of this Agreement.

11. Distribution Upgrades: None

12. Maintenance, Repair, and Replacement Charges:

The Interconnection Customer shall be responsible for actual costs incurred by APS, on behalf of the Transmission Owners, applicable to the maintenance, repair and replacement of the Transmission Owners' Interconnection Facilities, including but not limited to: the 500 kV disconnect switches, protection equipment for the Interconnection Customer's Interconnection Facilities, metering including CTs and PTs and communications equipment and all associated equipment (see Appendix C, Diagram). A good faith non-binding estimate of annual cost, for budgetary purposes only, is:

Estimate = \$ 1,000 per year

\$1,000 annually covers:

- Two inspections per year
- Relay maintenance (estimated at every 4-6 years)
- Disconnect switch maintenance (estimated at every 4-6 years)

Additional actual costs will be charged for:

- Emergency maintenance and repair work
- Replacement of failed or failing equipment

13. Provision of Security:

(a) Financial Security to be Posted: The amount available to be drawn under any credit support for the Transmission Owners' Interconnection Facilities and JPP Network Upgrades required to interconnect Phase B of the Generating Facility shall be:

APS Share (11.00%)	\$381,612	
IID Share (12.78%)	\$443,364	
Subtotal of APS and IID Shares (23.78%)		\$824,976
SDG&E Share (76.22%)		\$2,644,224
TOTAL (100%)		\$3,469,200

(b) Posting: The Interconnection Customer shall provide financial security for the Transmission Owners' Interconnection Facilities and JPP Network Upgrades no later than the milestone due date specified in Appendix B-2 in accordance with Article 11.5 of this Agreement. With respect to the financial security for APS and IID shares, Interconnection Customer shall post with APS, as Operating Agent, the amount for both the APS and IID shares specified in Section 13(a) of this Appendix A-2 in the form of one security instrument.

With respect to the Interconnection Financial Security for SDG&E, the amount posted shall be the amount SDG&E is to provide pursuant to Section 13(a) of this Appendix A-2. The Interconnection Financial Security shall be posted in accordance with the terms of the CAISO tariff.

The Parties agree that the Interconnection Customer shall be allowed to make substitutions of the security posted under this Agreement so long as the new security posted is reasonably acceptable to the Transmission Owners, as provided for in Article 11.5 of this Agreement, and in the amount required by this Agreement.

(c) Reduction of Amount of Security: Interconnection Customer shall make arrangements for financial security that provide for periodic reduction of the amount of the financial security upon receipt of instructions from APS, acting on behalf of the Transmission Owners. APS, on behalf of the Transmission Owners, shall provide periodic notices of reductions in the amount of the financial security required to be held to the financial institution(s) the Interconnection Customer selects to hold the financial security. APS shall provide such notices to the financial institution holding the security for the APS and IID shares in accordance with the arrangements made by the Interconnection Customer with the financial institution(s), provided, however, that the procedures for providing notice are reasonably

acceptable to APS. APS shall also provide notice to SDG&E and IID. Unless otherwise agreed by APS and the Interconnection Customer, APS shall provide notice monthly as payments are made in accordance with Article 12.1 and the financial security shall be reduced proportionately on a dollar-for-dollar by the payments made under this Agreement.

SDG&E agrees that within five (5) Calendar Days of receiving notice of a reduction in the amount of the security pursuant to this section, it shall inform the financial institution that holds the Interconnection Financial Security of the reduction in the amount of the security.

- (d) Increases to Security Required Due to Change of Cost Estimates.** In the event that APS, on behalf of the Transmission Owners, finds that the cost estimate for Transmission Owner Interconnection Facilities and Network Upgrades provided in this Appendix A-2 has increased, APS, on behalf of the Transmission Owners, shall have the option of (1) offsetting any reduction in the amount of security under Section 13(c) of this Appendix A-2 with the increase in the cost estimate, or (2) notifying Interconnection Customer of the required increase in its financial security to conform to the increased cost estimate.
- (e) Enforcement of Security for Transmission Owners' Interconnection Facilities and JPP Network Upgrades:** In the event that this Agreement is terminated in accordance with Article 2.3 and APS, on behalf of Transmission Owners, is required to determine the cost responsibility of the Interconnection Customer in accordance with Article 2.4 for Transmission Owners' Interconnection Facilities and JPP Network Upgrades set forth in this Appendix A-2, the Parties agree that in addition to following the procedures set forth elsewhere in the Agreement, the Transmission Owners shall proceed as follows:
- (1)** Subject to review and approval by all Transmission Owners, APS shall provide a statement indicating the total cost responsibility of the Interconnection Customer to all Transmission Owners and the allocation of this cost responsibility by Ownership Share ("Statement of Cost Responsibility"). This Statement of Cost Responsibility shall be accompanied by a detailed report which shows how the cost responsibility was determined, including information on all expenditures made on behalf of the Interconnection Customer, payments received, and bills outstanding.
 - (2)** If the Interconnection Customer has cost responsibility, upon providing the Statement of Cost Responsibility and accompanying information, APS, on behalf of both APS and IID, shall enforce their financial security rights in proportion to the combined Ownership Interests of APS and IID.
 - (3)** If the Interconnection Customer has cost responsibility, upon receipt of the Statement of Cost Responsibility and accompanying information, SDG&E shall enforce its financial security rights in proportion to the Ownership Interest of SDG&E. Within thirty (30) Calendar Days of receipt of the Statement of Cost Responsibility, SDG&E shall provide the funds it receives by enforcing its financial security rights to APS.
 - (4)** APS, acting on behalf of the Transmission Owners, shall use the funds provided by enforcing the financial security rights of the Transmission Owners to provide reimbursements and settle accounts proportionately in accordance with the Statement of Cost Responsibility and accompanying report.

14. Reporting Requirements:

From the date upon which authorization to proceed is provided pursuant to Article 5.1.1 for Phase B of the Generating Facility until the In-Service Date for Phase B of the Interconnection Project, Interconnection Customer and APS shall conduct a monthly meeting to coordinate the work related to

the Transmission Owners' Interconnection Facilities and JPP Network Upgrades in this Appendix A-2. APS shall submit a monthly written report to the Interconnection Customer in advance of the meeting that provides the following information:

- (a) Progress report on activities;
- (b) Project schedule update; and
- (c) Spending report, including actual expenditures to date and forecasted expenditures in accordance with standard accounting practices.

Appendix A-3

SDG&E Network Upgrades for Phase B of the Interconnection Project

If the interconnection studies determined to be necessary pursuant to Section 4 of Appendix C identify additional Network Upgrades to be constructed by SDG&E, the Parties shall amend this Agreement to incorporate provisions for those Network Upgrades into this Appendix A-3.

Appendix B-1

Milestones for Interconnection Facilities and JPP Network Upgrades for Phase A of the Interconnection Project

The Interconnection Customer has selected the Standard Option provided for in Article 5.1. Transmission Owners shall design, procure, and construct Transmission Owner's Interconnection Facilities and JPP Network Upgrades, using Reasonable Efforts to complete Transmission Owner's Interconnection Facilities and JPP Network Upgrades by the dates set forth in this Appendix B-1, Milestones. Milestone dates after October 1, 2010 may be adversely affected by an Effective Date later than October 1, 2010.

Milestones for Interconnection Facilities and JPP Network Upgrades for Phase A of the Interconnection Project	Responsible Party	Due Date
Begin design, permitting and land acquisition for line cut-in facilities	Operating Agent	E&P Agreement
Begin major equipment procurement specifications	Operating Agent	E&P Agreement
Complete planning and equipment specifications	Operating Agent	E&P Agreement
Begin above grade design	Operating Agent	E&P Agreement
Begin below grade design	Operating Agent	E&P Agreement
Submit estimate of Interconnection Customer payments under E&P Agreement and financial security posting requirements	Operating Agent	9/15/2010 or within 5 Calendar Days of Effective Date, if later
Submit interconnection financial security (Sections 5.6.4 and 11.5)	Interconnection Customer	Within 10 Calendar Days of receipt of financial security requirements
Complete transmission line and tower design	Operating Agent	5/31/10
Complete above grade design	Operating Agent	7/30/2010
Additional long lead time material procurement: Breakers, Switches	Operating Agent	Q2 2010
Submit written notice to proceed for procurement of towers	Interconnection Customer	6/1/2010
Complete below grade design	Operating Agent	8/11/10

Submit written authorization to APS to proceed with the construction of the Switchyard portion of Transmission Owners' 500kV Network Upgrades (Section 5.1.1 Standard Option)	Interconnection Customer	10/1/2010 or within 15 Calendar Days of Effective Date, if later
Submit written authorization to APS to proceed with the construction of the transmission line portion of Transmission Owners' 500kV JPP Network Upgrades (section 5.1.1 Standard Option)	Interconnection Customer	11/15/2010 or within 15 Calendar Days of Effective Date, if later
Complete land services/environmental	Operating Agent	12/27/2010
Complete installation of towers and tie line	Operating Agent	3/1/2011
Complete below grade work	Operating Agent	3/1/2011
Complete major equipment procurement	Operating Agent	6/13/2011
Complete material deliveries	Operating Agent	7/11/2011
Complete communications work	Operating Agent	8/22/2011
Complete above grade work	Operating Agent	11/2/2011
Complete control work	Operating Agent	11/3/2011
Line Drop Complete	Operating Agent	11/1/2011
Testing/Commissioning Complete	Operating Agent	12/1/2011
In-Service Date for JPP Network Upgrades and Transmission Owners' Interconnection Facilities	Operating Agent	12/1/2011
In-Service Date for Interconnection Customer's Interconnection Facilities	Interconnection Customer	12/1/2011
Initial Synchronization Date	Interconnection Customer	12/15/2011
Commercial Operation Date (COD) of Phase A of Generating Facility	Interconnection Customer	6/30/2014
Release date of financial security provided for in Appendix A-1 for Phase A of the Interconnection Project	Operating Agent	30 Calendar Days after COD

Early Operations

Given the modular nature of a photovoltaic solar facility, which is constructed in 1-2 MW Project Blocks, various stages of the Generating Facility will be added after Trial Operation of a Project Phase and will commence Commercial Operation prior to the Commercial Operation Date for the Project Phase. From the Initial Synchronization Date for each Project Phase, it is estimated that an additional 8-12 MW will be tested and commence Commercial Operation each month until the entire Project Phase is completed. Following the Initial Synchronization Date, Interconnection Customer will notify APS and CAISO at least ten (10) Calendar Days and not more than thirty (30) Calendar Days prior to the date each portion of the Project Phase with a generation capacity of at least one (1) MW but not more than twenty (20) MW will be completed and commence operation.

Further details regarding early operations will be included in an implementation plan. The proposed implementation plan shall be prepared by the Interconnection Customer and shall be submitted to APS, on behalf of Transmission Owners, and the CAISO for approval at least one-hundred twenty (120) Calendar Days prior to the scheduled In-Service Date for the Transmission Owners' Interconnection Facilities and JPP Network Upgrades for Phase A of the Interconnection Project. CAISO and APS, on behalf of Transmission Owners, shall provide written comments regarding the proposed implementation plan within thirty (30) Calendar Days of receipt. Interconnection Customer, CAISO, and APS shall work in good faith to finalize the implementation plan no later than sixty (60) Calendar Days prior to the scheduled In-Service Date.

Appendix B-2

Milestones for Interconnection Facilities and JPP Network Upgrades for Phase B of the Interconnection Project

The Interconnection Customer has selected the Standard Option provided for in Article 5.1. Transmission Owners shall design, procure, and construct Transmission Owner's Interconnection Facilities and JPP Network Upgrades, using Reasonable Efforts to complete Transmission Owner's Interconnection Facilities and JPP Network Upgrades by the dates set forth in this Appendix B-2, Milestones. Milestone dates after October 1, 2010 may be adversely affected by an Effective Date later than October 1, 2010.

Milestones for Interconnection Facilities and JPP Network Upgrades for Phase B of the Interconnection Project	Responsible Party	Due Date
Submit written notification to Parties of the intended Balancing Authority for Phase B of the Generating Facility	Interconnection Customer	3/15/2011
Complete review of all available studies to determine whether there is a need for additional interconnection studies regarding the possible impacts of Phase B of the Generating Facility on the CAISO Transmission System.	CAISO	4/15/2011
If additional interconnection studies are needed, provide notification to the Parties of the process for having such additional interconnection studies done in accordance with the applicable interconnection process.	CAISO	Note (1)
Complete review of all available studies to determine whether there is a need for additional Affected System Study regarding the possible impacts of Phase B of the Generating Facility on IID's non-JPP facilities.	IID	5/15/ 2011
If additional Affected System Study is needed, provide notification to the Parties of the process for having such additional studies done.	IID	Note (1)
Submit written authorization to proceed with long lead time material procurement and submit procurement financial security	Interconnection Customer	10/1/2011
Begin long lead time material procurement: Breakers, Switches	Operating Agent	1/15/2012
Submit written authorization to APS to proceed with the construction of Phase B of the Interconnection Project and submit construction financial security (Sections 5.6.4 and 11.5)	Interconnection Customer	5/1/2012
In-Service Date for JPP Network Upgrades and Transmission Owners' Interconnection Facilities (conditioned on available outage period)	Operating Agent	10/15/2012
In-Service Date for Interconnection Customer's Interconnection	Interconnection Customer	10/15/2012

Facilities		
Initial Synchronization Date	Interconnection Customer	11/1/2012
Commercial Operation Date (COD) of Phase B of the Generating Facility	Interconnection Customer	6/15/2015
Release date of financial security provided for in Appendix A-2 for Phase B of the Interconnection Project	Operating Agent	30 Calendar Days after COD

Note 1: If additional studies are required pursuant to Section 4 of Appendix C, the Parties will work together to amend this Agreement to modify this Appendix B-2 to establish a new schedule for Phase B of the Interconnection Project that is reasonably acceptable to all Parties.

Early Operations

Given the modular nature of a photovoltaic solar facility, which is constructed in 1-2 MW Project Blocks, various stages of the Generating Facility will be added after Trial Operation of a Project Phase and will commence Commercial Operation prior to the Commercial Operation Date for the Project Phase. From the Initial Synchronization Date for each Project Phase, it is estimated that an additional 8-12 MW will be tested and commence Commercial Operation each month until the entire Project Phase is completed. Following the Initial Synchronization Date, Interconnection Customer will notify APS and CAISO at least ten (10) Calendar Days and not more than thirty (30) Calendar Days prior to the date each portion of the Project Phase with a generation capacity of at least one (1) MW but not more than twenty (20) MW will be completed and commence operation.

Further details regarding early operations will be included in an implementation plan. The proposed implementation plan shall be prepared by the Interconnection Customer and shall be submitted to APS, on behalf of Transmission Owners, and the CAISO for approval at least one hundred twenty (120) Calendar Days prior to the scheduled In-Service Date for the Transmission Owners' Interconnection Facilities and JPP Network Upgrades for Phase B of the Interconnection Project. CAISO and APS, on behalf of Transmission Owners, shall provide written comments regarding the proposed implementation plan within thirty (30) Calendar Days of receipt. Interconnection Customer, CAISO, and APS shall work in good faith to finalize the implementation plan no later than sixty (60) Calendar Days prior to the scheduled In-Service Date.

Appendix B-3

Milestones for SDG&E Network Upgrades for Phase B of the Interconnection Project

If the interconnection studies determined to be necessary pursuant to Section 4 of Appendix C identify additional Network Upgrades to be constructed by SDG&E, the Parties shall amend this Agreement to incorporate milestones for the construction of those Network Upgrades into this Appendix B-3.

Appendix C

Interconnection Details

1. Description of the Large Generating Facility

The Generating Facility consists of a photovoltaic solar field, inverters, a medium voltage collection system, an operations and maintenance building, a 34.5kV/500kV substation and various other facilities. Phase A of the Generating Facility will consist of no more than 290 MW (net) of solar photovoltaic units installed at the site. Phase B of the Generating Facility will consist of no more than 210 MW (net). The Generating Facility will have with a total rated capacity of 500 MW based on both Phase A and Phase B achieving Commercial Operation.

Phase A of the Generating Facility will be interconnected to the Switchyard via a gen-tie line on the diagram below and Phase B of the Generating Facility will be interconnected to the Switchyard via a separate gen-tie line on the diagram.

2. Diagram Illustrating the Facilities at the Switchyard

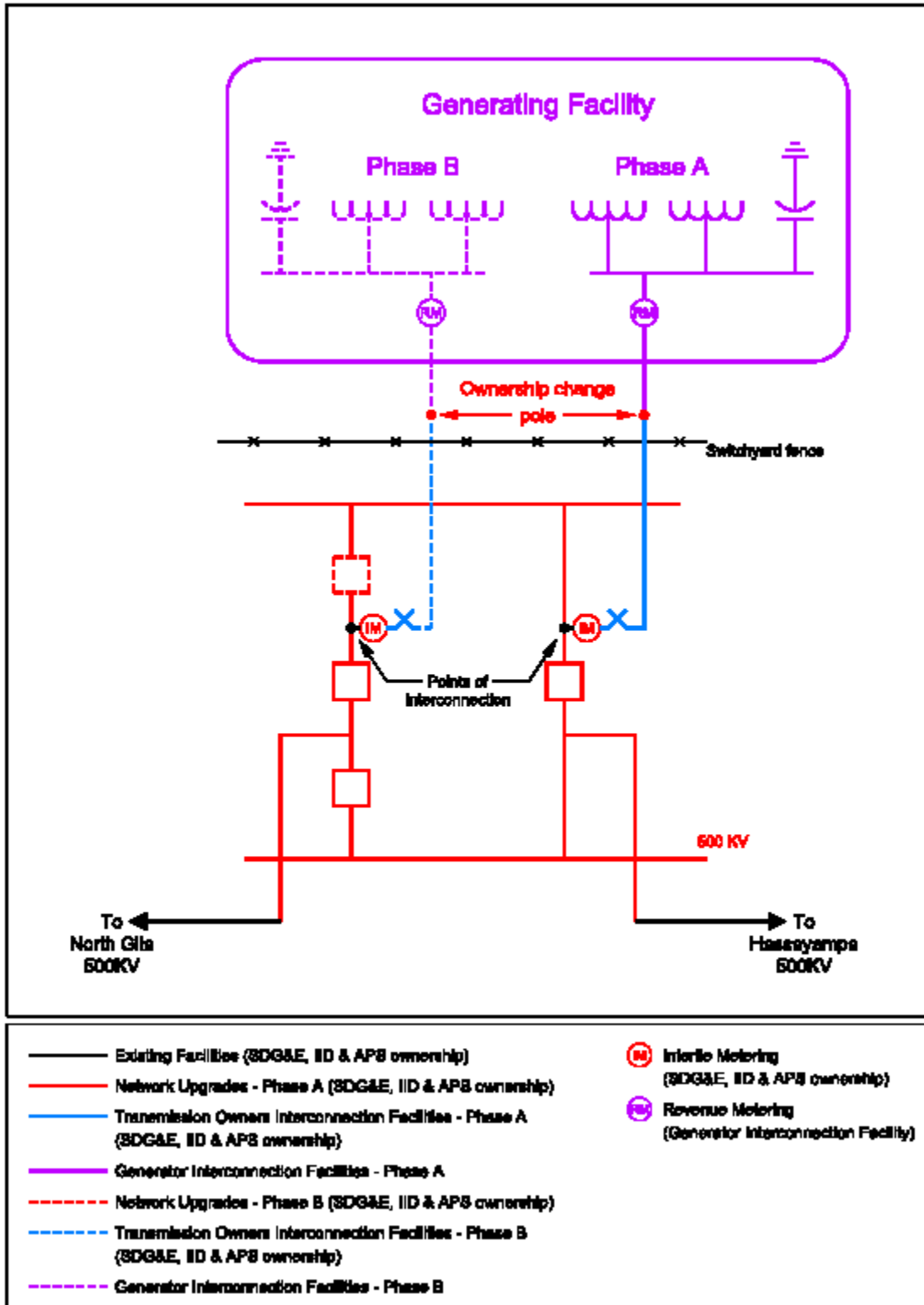

3. Balancing Authority Requirements:

If a Project Phase is to be under a Balancing Authority other than the APS's Balancing Authority, all executed agreements between Interconnection Customer and the other Balancing Authority relating to the Large Generating Facility shall be shared with APS, as the Operating Agent for the JPP.

4. Additional Conditions for Construction of Phase B of the Interconnection Project:

No later than March 15, 2011, Interconnection Customer shall notify the other Parties in writing of the intended Balancing Authority for Phase B of the Generating Facility. Construction of Phase B of the Interconnection Project shall not commence nor shall delivery of energy from Phase B of the Generating Facility to the Transmission System commence until all of the following actions have occurred:

- (a) Interconnection Customer will provide written authorization to APS to proceed with the construction of the Switchyard portion of Transmission Owners' 500kV Network Upgrades for Phase A of the Interconnection Project and Phase A of the Interconnection Project has not otherwise been suspended or terminated.
- (b) Within thirty (30) Calendar Days following receipt of the notice of intended Balancing Authority, the CAISO will review all available studies and determine whether there is a need for additional interconnection studies regarding the possible impacts of Phase B of the Generating Facility on the Transmission System.
- (c) If the CAISO concludes that there is a need for additional interconnection studies, within thirty (30) Calendar Days following receipt of the notice of intended Balancing Authority the CAISO will notify the Parties of the process for having CAISO conduct such additional interconnection studies, which may include the submittal by the Interconnection Customer of an additional Interconnection Request to the CAISO for Phase B of the Generating Facility in accordance with the CAISO's LGIP. Either in accordance with the CAISO's LGIP for a separate Interconnection Request for Phase B of the Generating Facility or pursuant to any other interconnection study process as specified by the CAISO or otherwise determined by FERC for the jurisdictional public utilities which are Parties to this Agreement, the CAISO and Interconnection Customer will enter into an interconnection study agreement under which the Interconnection Customer will agree to pay the reasonable and actual costs of the interconnection studies identified by the CAISO as needed, plus any study deposits required by the CAISO.
- (d) If the CAISO concludes on the basis of the studies provided for in Section 4(c) of this Appendix C that construction of additional facilities is required on the CAISO-controlled grid, this Agreement shall be amended to provide for construction of such facilities and for repayment of the cost of any such facilities that are Network Upgrades in accordance with the principles set forth in Article 11.4.2.
- (e) Within thirty (30) Calendar Days of its receipt of the notice provided by the CAISO in accordance with Section 4(c) of this Appendix C, IID shall determine whether there is a need for an additional Affected System Study regarding the possible impacts of Phase B of the Generating Facility on IID's Transmission System, other than IID's share of the JPP.
- (f) If IID concludes that there is a need for such an additional Affected System Study, IID shall notify the Parties of the process for having IID conduct such an additional Affected System Study and Interconnection Customer shall enter into an Affected System Study Agreement for Phase B of the Generating Facility.
- (g) If IID reasonably concludes on the basis of the studies provided for in Section 4(f) of this Appendix C that construction of additional IID Network Upgrades is required, the

Interconnection Customer and IID shall enter into an Affected System Construction and Operation Agreement for Phase B of the Generating Facility.

5. Joint and Several Liability for Entities Comprising Interconnection Customer

Except as otherwise provided, each entity comprising the Interconnection Customer shall be jointly and severally liable for all obligations required of the Interconnection Customer set forth in this Agreement, including all affirmative covenants and all monetary obligations, the latter of which includes the financing of all Interconnection Facilities and Network Upgrades that are required to be financed by the Interconnection Customer in order to accommodate the interconnection of the entire Generating Facility.

6. Representative of Entities Comprising Interconnection Customer

Agua Caliente Solar LLC and North Gila River Development, LLC shall appoint a single spokesperson, who shall serve as the Interconnection Customer's authorized agent and representative for purposes of administering this Agreement. The designated single spokesperson shall be a single point of contact for CAISO and Transmission Owners and will represent Interconnection Customer for notice purposes and all other communications between and among CAISO, Transmission Owners and Interconnection Customer. Except as otherwise provided, any invoices or refunds due to one of the entities comprising the Interconnection Customer by the Transmission Owners shall be made to the designated single spokesperson. The single spokesperson shall bear all responsibility for disseminating notices, communications and all interactions among the entities comprising the Interconnection Customer, and each entity comprising the Interconnection Customer hereby waives any right to individual notice or communication from CAISO or the Transmission Owners. The CAISO and the Transmission Owners will not be obligated to act on any instructions from either of the entities comprising the Interconnection Customer who is not the designated single spokesperson. The actions of the single spokesperson and his or her representations to CAISO and the Transmission Owners shall be binding upon the Interconnection Customer and each entity comprising the Interconnection Customer. This provision shall be of no further force and effect upon either the division of the Agreement obligations, as set forth in Section 7 of this Appendix C or the termination of Phase B of the Generating Facility, as set forth in Section 8 of this Appendix C.

7. Division of Agreement Obligations.

If the conditions for construction for Phase B of the Interconnection Project set out in Section 4 of this Appendix C have been met, the Interconnection Customer shall determine whether obtaining financing for the Generating Facility on commercially reasonable terms will require separate Large Generator Interconnection Agreements (LGIAs) for Phase A of the Generating Facility and Phase B of the Generating Facility. If the Interconnection Customer determines that separate LGIAs are needed, the Parties agree they shall negotiate in good faith to: (1) amend this Agreement solely for the purpose of making it apply only to Phase A of the Generating Facility and Phase A of the Interconnection Project; and (2) enter into a second LGIA for Phase B of the Generating Facility on terms that are substantially similar in all material relevant respects to this Agreement and to the amended version of this Agreement for Phase A of the Generating Facility. In such event, the joint and several liability set out in Section 5 of this Appendix C shall cease.

8. Termination of Phase B of the Generating Facility.

In addition to the termination right provided in Article 2.3 of this Agreement, and subject to its terms, those of Article 2.4 of the Agreement and any applicable Tariff, North Gila River Development, LLC may terminate this Agreement as it relates to Phase B of the Generating Facility provided the right to

terminate Phase B of the Generating Facility is conditioned on an obligation to fund the Network Upgrades set forth in Appendix A-2 in the event such termination constitutes a Material Modification of the Interconnection Request and is necessary to avoid adversely impacting lower queued interconnection customers. In the event North Gila River Development, LLC elects to terminate this Agreement as it relates to Phase B of the Generating Facility, this Agreement shall be amended accordingly so as to remove all references, terms and conditions pertaining to Phase B of the Generating Facility. Such termination shall leave unaffected the terms and conditions in this Agreement with respect to Phase A of the Generating Facility.

Appendix D

Security Arrangements Details

Infrastructure security of Transmission System equipment and operations and control hardware and software is essential to ensure day-to-day Transmission System reliability and operational security. FERC will expect all transmission providers, market participants, and Interconnection Customers interconnected to the Transmission System to comply with the recommendations offered by the President's Critical Infrastructure Protection Board and, eventually, best practice recommendations from the electric reliability authority. All public utilities will be expected to meet basic standards for system infrastructure and operational security, including physical, operational, and cyber-security practices.

If the Interconnection Customer selects the CAISO as the Balancing Authority for a Project Phase, for that Project Phase the Interconnection Customer shall meet the requirements for security implemented pursuant to the CAISO Tariff, including the CAISO's standards for information security posted on the CAISO's internet web site at the following internet address: <http://www.aiso.com/pubinfo/info-security/index.html>.

Appendix E

Commercial Operation Date

This Appendix E is a part of the Agreement.

[Date]

**Arizona Public Service Co.
Attn: Manager of Interconnection Development
MS 2259
P.O. Box 53999
Phoenix, AZ 85072-3999**

Mr. Stephen Rutt
Manager of Grid Assets
California Independent System Operator Corporation
151 Blue Ravine Road
Folsom, CA 95630

Mr. Robert Kott
Manager of Model & Contract Implementation
California Independent System Operator Corporation
151 Blue Ravine Road
Folsom, CA 95630

Re: Commercial Operation Date of Phase ___ of the Generating Facility

Dear _____:

On **[Date]** **[Interconnection Customer]** completed the last Project Block of Phase ___ of the Generating Facility. This letter confirms that the Commercial Operation Date of Phase ___ of the Generating Facility, is **[Date plus one day]** and that **[Entity Comprising Interconnection Customer]** provided the CAISO's operations personnel advance notice of this intended Commercial Operation Date no less than five Business Days prior to that date.

Thank you.

[Signature]

[Interconnection Customer Representative]

Appendix F

Addresses for Delivery of Notices and Billings

Notices:

Operating Agent:

Arizona Public Service Company
Attn: Manager of Interconnection Development
MS 2259
P.O. Box 53999
Phoenix, AZ 85072-3999

Transmission Owners:

Arizona Public Service Company
Attn: Manager of Interconnection Development
MS 2259
P.O. Box 53999
Phoenix, AZ 85072-3999

Imperial Irrigation District
Attention: Inter-Connect Transmission Contract Administrator
333 East Barioni Boulevard
PO Box 937
Imperial, CA 92251

San Diego Gas & Electric Company
Attn: Transmission Planning Manager
8316 Century Park Court; CP52A
San Diego, CA 92123-1593

California Independent System Operator Corporation

California ISO
Ms. Judy Brown
151 Blue Ravine Rd.
Folsom, CA 95630

Designated Single Spokesperson for Entities Comprising Interconnection Customer:

Agua Caliente Solar, LLC (Phase A) and North Gila River Development, LLC (Phase B)
Attn: : Jim Filippi, Director of Transmission
353 Sacramento St.
Suite 2100
San Francisco, CA 94111

With a copy to:
NextLight Renewable Power, LLC
Attn: Robert F. Miller, Vice President & General Counsel

353 Sacramento St.
Suite 2100
San Francisco, CA 94111

Billings and Payments:

Operating Agent:

Arizona Public Service Company
Attn: Manager of Interconnection Development
MS 2259
P.O. Box 53999
Phoenix, AZ 85072-3999

Interconnection Customer:

Agua Caliente Solar, LLC (Phase A) and North Gila River Development, LLC (Phase B)
Attn: Controller
353 Sacramento St.
Suite 2100
San Francisco, CA 94111

With a copy to:
NextLight Renewable Power, LLC
Attn: Jim Filippi, Director of Transmission
353 Sacramento St.
Suite 2100
San Francisco, CA 94111

California Independent System Operator Corporation

California ISO
Finance Dept.
Dennis Estrada
151 Blue Ravine Rd.
Folsom, CA 95630

Alternative Forms of Delivery of Notices (telephone, facsimile or email):

Transmission Owners:

Arizona Public Service Company
Attn: Manager, Interconnections Development
MS 2259
P.O. Box 53999
Phoenix, AZ 85072-3999

502 South 2nd Avenue, MS 2259
Phoenix, AZ 85003

Phone: (602) 250-1644
Facsimile: (602) 250-1674
Email: Rex.Stulting@aps.com

Imperial Irrigation District
Attention: Inter-Connect Transmission Contract Administrator
333 East Barioni Boulevard
PO Box 937
Imperial, CA 92251

San Diego Gas & Electric Company
Grid Operations Services Manager
Phone: 619-725-8637
Fax: 619-683-3291

California Independent System Operator Corporation
jbrown@caiso.com

Designated Single Spokesperson for Entities Comprising Interconnection Customer:

Agua Caliente Solar, LLC (Phase A) and North Gila River Development, LLC (Phase B)
Attn: Jim Filippi
353 Sacramento St.
Suite 2100
San Francisco, CA 94111

Phone: (415) 935-2498
Facsimile: (415) 935-2499
Email: jfilippi@nextlight.com

With a copy to:
NextLight Renewable Power, LLC
Attn: Robert F. Miller, Vice President & General Counsel
353 Sacramento St.
Suite 2100
San Francisco, CA 94111

Phone: (415) 935-2500
Facsimile: (415) 935-2501

For Billings:
Agua Caliente Solar, LLC (Phase A) and North Gila River Development, LLC (Phase B)
Attn: Controller
353 Sacramento St.
Suite 2100
San Francisco, CA 94111

Facsimile: (415) 935-2501
Email: ap@nextlight.com

Interconnection Customer Contact Information Regarding General Operating Issues

(Non Real-Time)

Interconnection Customer shall provide Contact information within 120 days of the expected energization of the Switchyard as part of the implementation plan.

Interconnection Customer Contact Information Regarding Real-Time Operating Issues

(Real-Time 24/7)

Interconnection Customer shall provide Contact information within 120 days of the expected energization of the Switchyard as part of the implementation plan.

Operating Agent Contact Information Regarding General Operating Issues

(Non Real-Time)

Arizona Public Service Company
Attn: Thomas Glock, Power Operations Manager
MS 2260
P.O. Box 53999
Phoenix, AZ 85072-3999

502 South 2nd Avenue, MS 2260
Phoenix, AZ 85003

Phone: APS shall provide within 120 days of the expected energization of the Switchyard
Facsimile: APS shall provide within 120 days of the expected energization of the Switchyard
Email: Thomas.Glock@aps.com

Operating Agent Contact Information Regarding Real-Time Operating Issues

(Real-Time 24/7)

APS Energy Control Center
ECC Supervisor

Transmission Issues

Phone: APS shall provide within 120 days of the expected energization of the Switchyard

Generation Issues

Phone: APS shall provide within 120 days of the expected energization of the Switchyard

Appendix G

Requirements of a Wind Generating Plant

Intentionally Omitted as Inapplicable

Appendix H

Reliability Management System Agreement

RELIABILITY MANAGEMENT SYSTEM AGREEMENT
by and between
[TRANSMISSION OPERATOR]
and
[GENERATOR]

THIS RELIABILITY MANAGEMENT SYSTEM AGREEMENT(the "Agreement"), is entered into this ____ day of _____, _____, by and between _____ (the "Transmission Operator") and _____ (the "Generator").

WHEREAS, there is a need to maintain the reliability of the interconnected electric systems encompassed by the WECC in a restructured and competitive electric utility industry;

WHEREAS, with the transition of the electric industry to a more competitive structure, it is desirable to have a uniform set of electric system operating rules within the Western Interconnection, applicable in a fair, comparable and non-discriminatory manner, with which all market participants comply; and

WHEREAS, the members of the WECC, including the Transmission Operator, have determined that a contractual Reliability Management System provides a reasonable, currently available means of maintaining such reliability.

NOW, THEREFORE, in consideration of the mutual agreements contained herein, and other good and valuable consideration, the receipt and sufficiency of which is hereby acknowledged, the Transmission Operator and the Generator agree as follows:

1. PURPOSE OF AGREEMENT

The purpose of this Agreement is to maintain the reliable operation of the Western Interconnection through the Generator's commitment to comply with certain reliability standards.

2. DEFINITIONS

In addition to terms defined in the beginning of this Agreement and in the Recitals hereto, for purposes of this Agreement the following terms shall have the meanings set forth beside them below.

Control Area means an electric system or systems, bounded by interconnection metering and telemetry, capable of controlling generation to maintain its interchange schedule with other Control Areas and contributing to frequency regulation of the Western Interconnection.

FERC means the Federal Energy Regulatory Commission or a successor agency.

Member means any party to the WECC Agreement.

Party means either the Generator or the Transmission Operator and **Parties** means both of the Generator and the Transmission Operator.

Reliability Management System or RMS means the contractual reliability management program implemented through the WECC Reliability Criteria Agreement, the WECC RMS Agreement, this Agreement, and any similar contractual arrangement.

Western Interconnection means the area comprising those states and provinces, or portions thereof, in Western Canada, Northern Mexico and the Western United States in which Members of the WECC operate synchronously connected transmission systems.

Working Day means Monday through Friday except for recognized legal holidays in the state in which any notice is received pursuant to Section 8.

WECC means the Western Electricity Coordinating Council or a successor entity.

WECC Agreement means the Western Electricity Coordinating Council Agreement dated March 20, 1967, as such may be amended from time to time.

WECC Reliability Criteria Agreement means the Western Electricity Coordinating Council Reliability Criteria Agreement dated _____, _____ among the WECC and certain of its member transmission operators, as such may be amended from time to time.

WECC RMS Agreement means an agreement between the WECC and the Transmission Operator requiring the Transmission Operator to comply with the reliability criteria contained in the WECC Reliability Criteria Agreement.

WECC Staff means those employees of the WECC, including personnel hired by the WECC on a contract basis, designated as responsible for the administration of the RMS.

3. TERM AND TERMINATION

3.1 Term. This Agreement shall become effective [thirty (30) days after the date of issuance of a final FERC order accepting this Agreement for filing without requiring any changes to this Agreement unacceptable to either Party. Required changes to this Agreement shall be deemed unacceptable to a Party only if that Party provides notice to the other Party within fifteen (15) days of issuance of the applicable FERC order that such order is unacceptable]. [Note: if the interconnection agreement is not FERC jurisdictional, replace bracketed language with: [on the later of: (a) the date of execution; or (b) the effective date of the WECC RMS Agreement.]

3.2 Notice of Termination of WECC RMS Agreement. The Transmission Operator shall give the Generator notice of any notice of termination of the WECC RMS Agreement by the WECC or by the Transmission Operator within fifteen (15) days of receipt by the WECC or the Transmission Operator of such notice of termination.

3.3 Termination by the Generator. The Generator may terminate this Agreement as follows:

(a) following the termination of the WECC RMS Agreement for any reason by the WECC or by the Transmission Operator, provided such notice is provided within forty-five (45) days of the termination of the WECC RMS Agreement;

(b) following the effective date of an amendment to the requirements of the WECC Reliability Criteria Agreement that adversely affects the Generator, provided notice of such termination is given within forty-five (45) days of the date of issuance of a FERC order accepting such amendment for filing, provided further that the forty-five (45) day period within which notice of termination is required may be extended by the Generator for an additional forty-five (45) days if the Generator gives written notice to the Transmission Operator of such requested extension within the initial forty-five (45) day period; or

(c) on one year's written notice to the Transmission Operator and the WECC, following any change in the WECC Reliability Criteria Agreement that materially affects Generator's obligations.

3.4 Termination by the Transmission Operator. The Transmission Operator may terminate this Agreement on thirty (30) days' written notice following the termination of the WECC RMS Agreement for any reason by the WECC or by the Transmission Operator, provided such notice is provided within thirty (30) days of the termination of the WECC RMS Agreement.

3.5 Mutual Agreement. This Agreement may be terminated at any time by the mutual agreement of the Transmission Operator and the Generator.

4. COMPLIANCE WITH AND AMENDMENT OF WECC RELIABILITY CRITERIA

4.1 Compliance with Reliability Criteria. The Generator agrees to comply with the requirements of the WECC Reliability Criteria Agreement, including the applicable WECC reliability criteria contained in Section IV of Annex A thereof, and, in the event of failure to comply, agrees to be subject to the sanctions applicable to such failure. Each and all of the provisions of the WECC Reliability Criteria Agreement are hereby incorporated by reference into this Agreement as though set forth fully herein, and the Generator shall for all purposes be considered a Participant, and shall be entitled to all of the rights and privileges and be subject to all of the obligations of a Participant, under and in connection with the WECC Reliability Criteria Agreement, including but not limited to the rights, privileges and obligations set forth in Sections 5, 6 and 10 of the WECC Reliability Criteria Agreement.

4.2 Modifications to WECC Reliability Criteria Agreement. The Transmission Operator shall notify the Generator within fifteen (15) days of the receipt of notice from the WECC of the initiation of any WECC process to modify the WECC Reliability Criteria Agreement. The WECC RMS Agreement specifies that such process shall comply with the procedures, rules, and regulations then applicable to the WECC for modifications to reliability criteria.

4.3 Notice of Modifications to WECC Reliability Criteria Agreement. If, following the process specified in Section 4.2, any modification to the WECC Reliability Criteria Agreement is to take effect, the Transmission Operator shall provide notice to the Generator at least forty-five (45) days before such modification is scheduled to take effect.

4.4 Effective Date. Any modification to the WECC Reliability Criteria Agreement shall take effect on the date specified by FERC in an order accepting such modification for filing.

4.5 Transfer of Control or Sale of Generation Facilities. In any sale or transfer of control of any generation facilities subject to this Agreement, the Generator shall as a condition of such sale or transfer require the acquiring party or transferee with respect to the transferred facilities either to assume the obligations of the Generator with respect to this Agreement or to enter into an agreement with the Control Area Operator in substantially the form of this Agreement.

5. SANCTIONS

5.1 Payment of Monetary Sanctions. The Generator shall be responsible for payment directly to the WECC of any monetary sanction assessed against the Generator pursuant to this Agreement and the WECC Reliability Criteria Agreement. Any such payment shall be made pursuant to the procedures specified in the WECC Reliability Criteria Agreement.

5.2 Publication. The Generator consents to the release by the WECC of information related to the Generator's compliance with this Agreement only in accordance with the WECC Reliability Criteria Agreement.

5.3 Reserved Rights. Nothing in the RMS or the WECC Reliability Criteria Agreement shall affect the right of the Transmission Operator, subject to any necessary regulatory approval, to take such other measures to maintain reliability, including disconnection, which the Transmission Operator may otherwise be entitled to take. Either Party shall have the right to make a unilateral filing with FERC to modify this Agreement with respect to any provision hereof under section 205, section 206, or any other applicable provision of the Federal Power Act and FERC's rules and regulations thereunder; provided that each Party shall have the right to protest any such filing by the other Party and to participate fully in any proceeding before FERC in which such modifications may be considered.

6. THIRD PARTIES

Except for the rights and obligations between the WECC and Generator specified in Sections 4 and 5, this Agreement creates contractual rights and obligations solely between the Parties. Nothing in this Agreement shall create, as between the Parties or with respect to the WECC: (1) any obligation or liability whatsoever (other than as expressly provided in this Agreement), or (2) any duty or standard of care whatsoever. In addition, nothing in this Agreement shall create any duty, liability, or standard of care whatsoever as to any other party. Except for the rights, as a third-party beneficiary with respect to Sections 4 and 5, of the WECC against Generator, no third party shall have any rights whatsoever with respect to enforcement of any provision of this Agreement. Transmission Operator and Generator expressly intend that the WECC is a third-party beneficiary to this Agreement, and the WECC shall have the right to seek to enforce against Generator any provisions of Sections 4 and 5, provided that specific performance shall be the sole remedy available to the WECC pursuant to this Agreement, and Generator shall not be liable to the WECC pursuant to this Agreement for damages of any kind whatsoever (other than the payment of sanctions to the WECC, if so construed), whether direct, compensatory, special, indirect, consequential, or punitive.

7. REGULATORY APPROVALS

This Agreement shall be filed with FERC by the Transmission Operator under Section 205 of the Federal Power Act. In such filing, the Transmission Operator shall request that FERC accept this Agreement for filing without modification to become effective on the day after the date of a FERC order accepting this Agreement for filing.

8. NOTICES

Any notice, demand or request required or authorized by this Agreement to be given in writing to a Party shall be delivered by hand, courier or overnight delivery service, mailed by certified mail (return receipt requested) postage prepaid, faxed, or delivered by mutually agreed electronic means to such Party at the following address:

_____:

Fax: _____

Fax: _____

The designation of such person and/or address may be changed at any time by either Party upon receipt by the other of written notice. Such a notice served by mail shall be effective upon receipt. Notice transmitted by facsimile shall be effective upon receipt if received prior to 5:00 p.m. on a Working Day, and if not received prior to 5:00 p.m. on a Working Day, receipt shall be effective on the next Working Day.

9. APPLICABILITY

This Agreement (including all appendices hereto and, by reference, the WECC Reliability Criteria Agreement) constitutes the entire understanding between the Parties hereto with respect to the subject matter hereof, supersedes any and all previous understandings between the Parties with respect to the subject matter hereof, and binds and inures to the benefit of the Parties and their successors.

10. AMENDMENT

No amendment of all or any part of this Agreement shall be valid unless it is reduced to writing and signed by both Parties hereto. The terms and conditions herein specified shall remain in effect throughout the term and shall not be subject to change through application to the FERC or other governmental body or authority, absent the agreement of the Parties.

11. INTERPRETATION

Interpretation and performance of this Agreement shall be in accordance with, and shall be controlled by, the laws of the State of _____ but without giving effect to the provisions thereof relating to conflicts of law. Article and section headings are for convenience only and shall not affect the interpretation of this Agreement. References to articles, sections and appendices are, unless the context otherwise requires, references to articles, sections and appendices of this Agreement.

12. PROHIBITION ON ASSIGNMENT

This Agreement may not be assigned by either Party without the consent of the other Party, which consent shall not be unreasonably withheld; provided that the Generator may without the consent of the WECC or Transmission Operator assign this Agreement (a) as collateral security to aid in providing financing or refinancing for the construction, ownership or operation of the Generator's power generating facility, or (b) to any acquiring party or transferee referenced in Section 4.5 of this Agreement. If requested by Generator, Transmission Operator will enter into a consent on commercially reasonable terms to any assignment of this Agreement by Generator under this Section 12.

13. SEVERABILITY

If one or more provisions herein shall be invalid, illegal or unenforceable in any respect, it shall be given effect to the extent permitted by applicable law, and such invalidity, illegality or unenforceability shall not affect the validity of the other provisions of this Agreement.

14. COUNTERPARTS

This Agreement may be executed in counterparts and each shall have the same force and effect as an original.

IN WITNESS WHEREOF, the Transmission Operator and the Generator have each caused this Reliability Management System Agreement to be executed by their respective duly authorized officers as of the date first above written.

By: _____
Name:
Title:

By: _____
Name:
Title:

ATTACHMENT B-2

Service Agreement No. 27

under

**San Diego Gas & Electric Company
FERC Electric Tariff, Original Volume No. 11**

**LARGE GENERATOR
INTERCONNECTION AGREEMENT**

BY AND BETWEEN

**AGUA CALIENTE SOLAR, LLC, AND NORTH GILA RIVER DEVELOPMENT, LLC
AS INTERCONNECTION CUSTOMER**

AND

**ARIZONA PUBLIC SERVICE COMPANY,
IMPERIAL IRRIGATION DISTRICT,
SAN DIEGO GAS & ELECTRIC COMPANY, AND
CALIFORNIA INDEPENDENT SYSTEM OPERATOR CORPORATION**

SERVICE AGREEMENT NO. 27

Issued by: Lee Schavrien
Vice President, Regulatory Affairs
Issued on: May 28, 2010

Docket: ER10-___-___
Effective: July 28, 2010

TABLE OF CONTENTS

	Page
RECITALS	1
ARTICLE 1 DEFINITIONS	3
ARTICLE 2 EFFECTIVE DATE, TERM, AND TERMINATION	11
2.1 EFFECTIVE DATE.	11
2.2 TERM OF AGREEMENT	12
2.3 TERMINATION PROCEDURES	12
2.3.1 WRITTEN NOTICE	12
2.3.2 DEFAULT	12
2.4 TERMINATION COSTS.....	12
2.5 DISCONNECTION	14
2.6 SURVIVAL	14
ARTICLE 3. REGULATORY FILINGS	14
3.1 FILING.....	15
ARTICLE 4. SCOPE OF SERVICE.....	15
4.1 INTERCONNECTION PRODUCT OPTIONS.....	15
4.1.1 CAISO INTERCONNECTION SERVICE	15
4.1.2 ENERGY RESOURCE INTERCONNECTION SERVICE.....	15
4.1.2.1 THE PRODUCT	15
4.1.2.2 TRANSMISSION DELIVERY SERVICE IMPLICATIONS.....	15
4.1.3 NETWORK RESOURCE INTERCONNECTION SERVICE.....	16
4.1.3.1 THE PRODUCT	16
4.1.3.2 TRANSMISSION DELIVERY SERVICE IMPLICATIONS.....	16
4.2 PROVISION OF SERVICE	16
4.3 PERFORMANCE STANDARDS	16
4.4 NO TRANSMISSION DELIVERY SERVICE	16
4.5 INTERCONNECTION CUSTOMER PROVIDED SERVICES	16
ARTICLE 5. INTERCONNECTION FACILITIES ENGINEERING, PROCUREMENT, AND CONSTRUCTION	16
5.1 OPTIONS.....	17
5.1.1 STANDARD OPTION.....	17

5.1.2	ALTERNATE OPTION	17
5.1.3	OPTION TO BUILD	17
5.1.4	NEGOTIATED OPTION.....	17
5.2	GENERAL CONDITIONS APPLICABLE TO OPTION TO BUILD.....	17
5.3	LIQUIDATED DAMAGES.....	17
5.4	POWER SYSTEM STABILIZERS	17
5.5	EQUIPMENT PROCUREMENT.....	18
5.6	CONSTRUCTION COMMENCEMENT.....	18
5.7	WORK PROGRESS.....	18
5.8	INFORMATION EXCHANGE	19
5.9	LIMITED OPERATION.....	19
5.10	INTERCONNECTION CUSTOMER’S INTERCONNECTION FACILITIES (‘ICIF’).....	19
5.10.1	INTERCONNECTION CUSTOMER’S INTERCONNECTION FACILITY SPECIFICATIONS	19
5.10.2	REVIEW BY TRANSMISSION OWNERS AND CAISO.....	19
5.10.3	ICIF CONSTRUCTION	20
5.11	TRANSMISSION OWNERS’ INTERCONNECTION FACILITIES CONSTRUCTION.....	20
5.12	ACCESS RIGHTS	20
5.13	LANDS OF OTHER PROPERTY OWNERS	21
5.14	PERMITS.....	21
5.15	EARLY CONSTRUCTION OF BASE CASE FACILITIES.....	21
5.16	SUSPENSION.....	21
5.17	TAXES.....	22
5.17.1	INTERCONNECTION CUSTOMER PAYMENTS NOT TAXABLE	22
5.17.2	REPRESENTATIONS AND COVENANTS	22
5.17.3	INDEMNIFICATION FOR THE COST CONSEQUENCES OF CURRENT TAX LIABILITY IMPOSED UPON THE TRANSMISSION OWNER.....	23
5.17.4	TAX GROSS-UP AMOUNT.....	23
5.17.5	PRIVATE LETTER RULING OR CHANGE OR CLARIFICATION OF LAW	24
5.17.6	SUBSEQUENT TAXABLE EVENTS	24
5.17.7	CONTESTS.....	24
5.17.8	REFUND	25

5.17.9	TAXES OTHER THAN INCOME TAXES.....	26
5.18	TAX STATUS	27
5.19	MODIFICATION.....	27
5.19.1	GENERAL	27
5.19.2	STANDARDS	28
5.19.3	MODIFICATION COSTS	28
ARTICLE 6.	TESTING AND INSPECTION.....	28
6.1	PRE-COMMERCIAL OPERATION DATE TESTING AND MODIFICATIONS	28
6.2	POST-COMMERCIAL OPERATION DATE TESTING AND MODIFICATIONS	29
6.3	RIGHT TO OBSERVE TESTING.....	29
6.4	RIGHT TO INSPECT	29
ARTICLE 7.	METERING	29
7.1	GENERAL	29
7.2	CHECK METERS	30
7.3	STANDARDS	30
7.4	TESTING OF METERING EQUIPMENT	30
7.5	METERING DATA	30
7.6	METERING REQUIREMENTS OF CAISO.....	30
ARTICLE 8.	COMMUNICATIONS.....	31
8.1	INTERCONNECTION CUSTOMER OBLIGATIONS	31
8.2	REMOTE TERMINAL UNIT	31
8.3	NO ANNEXATION	32
8.4	COMMUNICATION REQUIREMENTS OF CAISO.....	32
ARTICLE 9.	OPERATIONS	32
9.1	GENERAL	32
9.2	BALANCING AUTHORITY AREA NOTIFICATION.....	32
9.3	TRANSMISSION OWNER AND CAISO OBLIGATIONS	32
9.4	INTERCONNECTION CUSTOMER OBLIGATIONS	32
9.5	START-UP AND SYNCHRONIZATION.....	33
9.6	REACTIVE POWER	33
9.6.1	POWER FACTOR DESIGN CRITERIA	33
9.6.2	VOLTAGE SCHEDULES	33

9.6.2.1	GOVERNORS AND REGULATORS.....	34
9.6.3	PAYMENT FOR REACTIVE POWER.....	34
9.7	OUTAGES AND INTERRUPTIONS.....	34
9.7.1	OUTAGES	34
9.7.1.1	OUTAGE AUTHORITY AND COORDINATION.....	34
9.7.1.2	OUTAGE SCHEDULES	35
9.7.1.3	OUTAGE RESTORATION.....	35
9.7.2	INTERRUPTION OF SERVICE.....	36
9.7.3	UNDER-FREQUENCY AND OVER FREQUENCY CONDITIONS.....	37
9.7.4	SYSTEM PROTECTION AND OTHER CONTROL REQUIREMENTS.....	37
9.7.4.1	SYSTEM PROTECTION FACILITIES	37
9.7.5	REQUIREMENTS FOR PROTECTION.....	38
9.7.6	POWER QUALITY.....	38
9.8	SWITCHING AND TAGGING RULES.....	38
9.9	USE OF INTERCONNECTION FACILITIES BY THIRD PARTIES.....	38
9.9.1	PURPOSE OF INTERCONNECTION FACILITIES	39
9.9.2	THIRD PARTY USERS	39
9.10	DISTURBANCE ANALYSIS DATA EXCHANGE.....	39
ARTICLE 10.	MAINTENANCE.....	39
10.1	TRANSMISSION OWNER OBLIGATIONS.....	39
10.2	INTERCONNECTION CUSTOMER OBLIGATIONS	39
10.3	COORDINATION.....	39
10.4	SECONDARY SYSTEMS	40
10.5	OPERATING AND MAINTENANCE EXPENSES.....	40
ARTICLE 11.	PERFORMANCE OBLIGATION.....	40
11.1	INTERCONNECTION CUSTOMER INTERCONNECTION FACILITIES.....	40
11.2	TRANSMISSION OWNERS' INTERCONNECTION FACILITIES	40
11.3	NETWORK UPGRADES AND DISTRIBUTION UPGRADES.....	40
11.4	TRANSMISSION CREDITS	40
11.4.1	REPAYMENT OF AMOUNTS ADVANCED TO APS FOR NETWORK UPGRADES TO APS'S SHARE OF THE JPP.....	40

11.4.2	REPAYMENT OF AMOUNTS ADVANCED TO SDG&E FOR NETWORK UPGRADES TO ITS SHARE OF THE JPP AND TO ITS NON-JPP FACILITIES	41
11.4.3	REPAYMENT OF AMOUNTS ADVANCED TO IID FOR NETWORK UPGRADES TO IID’S SHARE OF THE JPP.....	42
11.4.4	SPECIAL PROVISIONS FOR AFFECTED SYSTEMS	43
11.5	PROVISION OF SECURITY.....	44
11.6	INTERCONNECTION CUSTOMER COMPENSATION.....	46
11.6.1	INTERCONNECTION CUSTOMER COMPENSATION FOR ACTIONS DURING EMERGENCY CONDITION.....	46
ARTICLE 12.	INVOICE	46
12.1	GENERAL PROVISIONS	46
12.2	FINAL INVOICE.....	47
12.3	PAYMENT.....	47
12.4	DISPUTES	47
ARTICLE 13.	EMERGENCIES	48
13.1	DEFINITION	48
13.2	OBLIGATIONS.....	48
13.3	NOTICE	48
13.4	IMMEDIATE ACTION.....	48
13.5	TRANSMISSION OWNER AND CAISO AUTHORITY	49
13.5.1	GENERAL	49
13.5.2	REDUCTION AND DISCONNECTION.....	49
13.6	INTERCONNECTION CUSTOMER AUTHORITY	50
13.7	LIMITED LIABILITY	50
ARTICLE 14.	REGULATORY REQUIREMENTS AND GOVERNING LAW	50
14.1	REGULATORY REQUIREMENTS.....	50
14.2	GOVERNING LAW.....	50
ARTICLE 15.	NOTICES.....	50
15.1	GENERAL	50
15.2	BILLINGS AND PAYMENTS.....	51
15.3	ALTERNATIVE FORMS OF NOTICE	51
15.4	OPERATIONS AND MAINTENANCE NOTICE.....	51

ARTICLE 16.	FORCE MAJEURE.....	51
ARTICLE 17.	DEFAULT	51
17.1	DEFAULT	51
17.1.1	GENERAL	51
17.1.2	RIGHT TO TERMINATE.....	52
ARTICLE 18.	INDEMNITY, CONSEQUENTIAL DAMAGES AND INSURANCE.....	52
18.1	INDEMNITY	52
18.1.1	INDEMNIFIED PARTY	52
18.1.2	INDEMNIFYING PARTY	52
18.1.3	INDEMNITY PROCEDURES	52
18.2	CONSEQUENTIAL DAMAGES.....	53
18.3	INSURANCE	53
ARTICLE 19.	ASSIGNMENT	55
ARTICLE 20.	SEVERABILITY	55
ARTICLE 21.	COMPARABILITY	56
ARTICLE 22.	CONFIDENTIALITY	56
22.1	CONFIDENTIALITY	56
22.1.1	TERM	56
22.1.2	SCOPE	56
22.1.3	RELEASE OF CONFIDENTIAL INFORMATION	57
22.1.4	RIGHTS.....	57
22.1.5	NO WARRANTIES	57
22.1.6	STANDARD OF CARE	57
22.1.7	DISCLOSURE REQUIRED BY LAW OR ORDER	57
22.1.8	TERMINATION OF AGREEMENT	58
22.1.9	REMEDIES	58
22.1.10	DISCLOSURE TO FERC, ITS STAFF, OR A STATE.....	58
ARTICLE 23.	ENVIRONMENTAL RELEASES.....	59
ARTICLE 24.	INFORMATION REQUIREMENTS	59
24.1	INFORMATION ACQUISITION	59
24.2	INFORMATION SUBMISSION BY APS, ON BEHALF OF TRANSMISSION OWNERS.....	59
24.3	UPDATED INFORMATION SUBMISSION BY INTERCONNECTION CUSTOMER.....	59

24.4	INFORMATION SUPPLEMENTATION.....	60
ARTICLE 25.	INFORMATION ACCESS AND AUDIT RIGHTS	61
25.1	INFORMATION ACCESS.....	61
25.2	REPORTING OF NON-FORCE MAJEURE EVENTS.....	61
25.3	AUDIT RIGHTS	61
25.4	AUDIT RIGHTS PERIODS	61
	25.4.1 AUDIT RIGHTS PERIOD FOR CONSTRUCTION-RELATED ACCOUNTS AND RECORDS.....	62
	25.4.2 AUDIT RIGHTS PERIOD FOR ALL OTHER ACCOUNTS AND RECORDS	62
25.5	AUDIT RESULTS	62
ARTICLE 26.	SUBCONTRACTORS.....	62
26.1	GENERAL	62
26.2	RESPONSIBILITY OF PRINCIPAL	62
26.3	NO LIMITATION BY INSURANCE	62
ARTICLE 27.	DISPUTES	62
27.1	SUBMISSION.....	63
27.2	EXTERNAL ARBITRATION PROCEDURES.....	63
27.3	ARBITRATION DECISIONS.....	63
27.4	COSTS	63
ARTICLE 28.	REPRESENTATIONS, WARRANTIES, AND COVENANTS	63
28.1	GENERAL	64
	28.1.1 GOOD STANDING	64
	28.1.2 AUTHORITY	64
	28.1.3 NO CONFLICT	64
	28.1.4 CONSENT AND APPROVAL.....	64
ARTICLE 29.	JOINT OPERATING COMMITTEE.....	64
ARTICLE 30.	MISCELLANEOUS	65
30.1	BINDING EFFECT.....	65
30.2	CONFLICTS.....	65
30.3	RULES OF INTERPRETATION	65
30.4	ENTIRE AGREEMENT.....	66
30.5	NO THIRD PARTY BENEFICIARIES	66

30.6	WAIVER	66
30.7	HEADINGS	66
30.8	MULTIPLE COUNTERPARTS	66
30.9	AMENDMENT	66
30.10	MODIFICATION BY THE PARTIES	66
30.11	RESERVATION OF RIGHTS	67
30.12	NO PARTNERSHIP.....	67
30.13	JOINT AND SEVERAL OBLIGATIONS.....	67

APPENDICES

Appendix A-1	Interconnection Facilities, JPP Network Upgrades, and Distribution Upgrades for Phase A of the Interconnection Project
Appendix A-2	Interconnection Facilities, JPP Network Upgrades, and Distribution Upgrades for Phase B of the Interconnection Project
Appendix A-3	SDG&E Network Upgrades for Phase B of the Interconnection Project
Appendix B-1	Milestones for Interconnection Facilities and JPP Network Upgrades for Phase A of the Interconnection Project
Appendix B-2	Milestones for Interconnection Facilities and JPP Network Upgrades for Phase B of the Interconnection Project
Appendix B-3	Milestones for SDG&E Network Upgrades for Phase B of the Interconnection Project
Appendix C	Interconnection Details
Appendix D	Security Arrangements Details
Appendix E	Commercial Operation Date
Appendix F	Addresses for Delivery of Notices and Billings
Appendix G	Requirements of a Wind Generating Plant
Appendix H	Reliability Management System Agreement

LARGE GENERATOR INTERCONNECTION AGREEMENT

THIS LARGE GENERATOR INTERCONNECTION AGREEMENT

("Agreement") is made and entered into this ____ day of _____ 20__, by and between Agua Caliente Solar, LLC, to which NextLight Renewable Power, LLC ("NextLight") has duly assigned its Interconnection Requests only as to Phase A of the Generating Facility, and North Gila River Development, LLC, to which NextLight has duly assigned its Interconnection Request submitted only to APS only as to Phase B of the Generating Facility, each of which is a corporation organized and existing under the laws of the State of Delaware, (collectively Agua Caliente Solar, LLC and North Gila River Development, LLC are the "Interconnection Customer" with a Large Generating Facility), and Arizona Public Service Company ("APS"), a corporation organized and existing under the laws of the State of Arizona, Imperial Irrigation District ("IID"), an irrigation district organized under the Water Code of the State of California, San Diego Gas & Electric Company ("SDG&E"), a corporation organized under the laws of the State of California, and California Independent System Operator Corporation ("CAISO"), a nonprofit public benefit corporation organized and existing under the laws of California. Interconnection Customer, APS, IID, SDG&E and CAISO each may be referred to as a "Party" or collectively as the "Parties."

Recitals

WHEREAS, APS and SDG&E entered into the Arizona Transmission System Participation Agreement, dated June 24, 1981 ("Participation Agreement");

WHEREAS, APS, IID, and SDG&E entered into Amendment No. 1 to the Participation Agreement, dated January 22, 1985 ("Amendment No. 1"), pursuant to which SDG&E assigned and transferred an undivided interest in the Arizona Transmission System to IID;

WHEREAS, APS, IID, and SDG&E ("Joint Participants" or "Transmission Owners") own the Joint Participation Project ("JPP") as set forth in the Participation Agreement, amended by Amendment No. 1;

WHEREAS, APS acts as the Operating Agent of the JPP pursuant to the Participation Agreement, as amended;

WHEREAS, APS and the CAISO are parties to the Interconnected Control Area Operating Agreement, dated November 26, 1997;

WHEREAS, APS, IID, SDG&E, and the CAISO provide transmission service on their respective Transmission Systems;

WHEREAS, Interconnection Customer intends to own, lease and/or control and operate the Generating Facility identified as a Large Generating Facility in Appendix C to this Agreement;

WHEREAS, NextLight, submitted an Interconnection Request for such Large Generating Facility to APS on February 22, 2008, and also submitted an Interconnection Request for Phase A of the Large Generating Facility to CAISO on June 2, 2008;

WHEREAS, NextLight and APS, on behalf of the Joint Participants, entered into an Engineering & Procurement Agreement dated March 30, 2010, to begin design and procurement work for certain Interconnection Facilities to be constructed pursuant to this Agreement and NextLight duly assigned the Engineering & Procurement Agreement to Agua Caliente Solar, LLC;

WHEREAS, the Parties have agreed to enter into this Agreement for the purpose of interconnecting the Large Generating Facility with the JPP; and

WHEREAS, all Parties that are public utilities subject to the jurisdiction of the Federal Energy Regulatory Commission (“FERC”) will file this Agreement simultaneously, as a service agreement under their respective Tariffs.

NOW, THEREFORE, in consideration of and subject to the mutual covenants contained herein, it is agreed:

When used in this Agreement, terms with initial capitalization that are not defined in Article 1 shall have the meanings specified in the Article in which they are used or in the APS Open Access Transmission Tariff or the CAISO Tariff, as applicable.

When an Article of this Agreement contains the phrase “THIS ARTICLE IS NOT APPLICABLE TO THIS AGREEMENT,” or “THIS SECTION IS NOT APPLICABLE TO THIS AGREEMENT,” or “THIS PARAGRAPH IS NOT APPLICABLE TO THIS AGREEMENT,” or when an Appendix to this Agreement contains the phrase “THIS APPENDIX IS NOT APPLICABLE TO THIS AGREEMENT,” the Article, Section, Paragraph or Appendix will have no force and effect with respect to this Agreement.

Article 1. Definitions

Adverse System Impact shall mean the negative effects due to technical or operational limits on conductors or equipment being exceeded that may compromise the safety and reliability of the electric system.

Affected System shall mean an electric system other than the APS or SDG&E's Transmission Systems or IID's share of the JPP that may be affected by the proposed interconnection.

Affected System Operator shall mean the entity that operates an Affected System.

Affected System Construction and Operation Agreement shall mean an agreement between the Interconnection Customer and IID to pay the costs of Network Upgrades, for either of the Project Phases, to IID's Transmission System, other than IID's share of the JPP, and to provide for repayment of amounts advanced to IID with transmission rate credits when transmission service is taken on IID's Transmission System.

Affected System Study shall mean an engineering study that evaluates the impacts of the proposed interconnection of either Project Phase on the safety and reliability of the Transmission System owned by IID, other than IID's share of the JPP, and provides a list of facilities that are required as a result of proposed interconnection, along with an estimate of cost responsibility and time to construct. This Affected System Study may be performed, at IID's option, either serially or in a cluster.

Affected System Study Agreement shall mean an agreement between the Interconnection Customer and IID whereby IID will perform and Interconnection Customer will pay the costs of an Affected System Study. The total costs will be pro rated to the extent IID performs the Affected System Study in a cluster for multiple generators seeking to interconnect to the CAISO controlled grid, with Interconnection Customer allocated a proportionate share of the total costs.

Affiliate shall mean, with respect to a corporation, partnership or other entity, each such other corporation, partnership or other entity that directly or indirectly, through one or more intermediaries, controls, is controlled by, or is under common control with, such corporation, partnership or other entity.

Ancillary Services shall mean those services that are necessary to support the transmission of capacity and energy from resources to loads while maintaining reliable operation of the Transmission System in accordance with Good Utility Practice.

Applicable Laws and Regulations shall mean all duly promulgated applicable federal, state and local laws, regulations, rules, ordinances, codes, decrees, judgments, directives, or judicial or administrative orders, permits and other duly authorized actions of any Governmental Authority.

Applicable Reliability Council shall mean the Western Electricity Coordinating Council or its successor.

Applicable Reliability Standards shall mean the requirements and guidelines of NERC, the Applicable Reliability Council, and the applicable Balancing Authority.

Balancing Authority shall mean the responsible entity that integrates resource plans ahead of time, maintains load-interchange-generation balance within a Balancing Authority Area, and supports interconnection frequency in real time.

Balancing Authority Area shall mean the collection of generation, transmission, and loads within the metered boundaries of the Balancing Authority. The Balancing Authority maintains load resource balance within this area.

Base Case shall mean the base case power flow, short circuit, and stability data bases used for the Interconnection Studies by APS, the CAISO and its designees, or Interconnection Customer.

Breach shall mean the failure of a Party to perform or observe any material term or condition of this Agreement.

Breaching Party shall mean a Party that is in Breach of this Agreement.

Business Day shall mean Monday through Friday, excluding Federal Holidays and the day after Thanksgiving Day.

Calendar Day shall mean any day including Saturday, Sunday or a Federal Holiday.

CAISO Interconnection Service shall have the meaning set forth in Article 4.1.1.

Clustering shall mean the process whereby a group of Interconnection Requests is studied together, instead of serially, for the purpose of conducting the Interconnection System Impact Study.

Commercial Operation shall mean the status of a Project Block at a Generating Facility that has commenced generating electricity for sale, excluding electricity generated during Trial Operation.

Commercial Operation Date shall mean the date on which the Interconnection Customer declares completion of all Project Blocks within a Project Phase, as described in Appendix E to this Agreement and in accordance with the implementation plan agreed to by the Parties for multiple Project Blocks at the Generating Facility.

Confidential Information shall mean any confidential, proprietary or trade secret information of a plan, specification, pattern, procedure, design, device, list, concept, policy or compilation relating to the present or planned business of a Party, which is designated as confidential by the Party supplying the information, whether conveyed orally, electronically, in writing, through inspection, or otherwise, subject to Article 22.1.2.

Default shall mean the failure of a Breaching Party to cure its Breach in accordance with Article 17 of this Agreement.

Dispute Resolution shall mean the procedure for resolution of a dispute between the Parties in which they will first attempt to resolve the dispute on an informal basis.

Distribution System shall mean each of the respective facilities and equipment of APS, IID or SDG&E used to transmit electricity to ultimate usage points such as homes and industries directly from nearby generators or from interchanges with higher voltage transmission networks which transport bulk power over longer distances. The voltage levels at which distribution systems operate differ among areas.

Distribution Upgrades shall mean the additions, modifications, and upgrades to the Distribution System at or beyond the Point of Interconnection to facilitate interconnection of the Generating Facility and render the transmission service necessary to effect Interconnection Customer's wholesale sale of electricity in interstate commerce. Distribution Upgrades do not include Interconnection Facilities.

Effective Date shall mean the date on which this Agreement becomes effective upon execution by the Parties subject to acceptance by FERC, or if filed unexecuted pursuant to Section 205 of the Federal Power Act, upon the date specified by FERC, for those Parties which are FERC-jurisdictional public utilities; provided, however, that, as applied to IID, the Effective Date of this Agreement shall not commence until the Agreement is actually executed by IID, either voluntarily or pursuant to a lawful order issued by FERC in accordance with Sections 210 and 212 of the Federal Power Act.

Emergency Condition shall mean a condition or situation: (1) that in the judgment of the Party making the claim is imminently likely to endanger life or property; or (2) that, in the case of a Transmission Owner or the CAISO, is imminently likely (as determined in a non-discriminatory manner) to cause a material adverse effect on the security of, or damage to its Transmission System, its Interconnection Facilities or the electric systems of others to which its Transmission System is directly connected; or (3) that, in the case of Interconnection Customer, is imminently likely (as determined in a non-discriminatory manner) to cause a material adverse effect on the security of, or damage to, the Generating Facility or Interconnection Customer's Interconnection Facilities. System restoration and black start shall be considered Emergency Conditions; provided, that Interconnection Customer is not obligated by this Agreement to possess black start capability.

Energy Resource Interconnection Service shall mean an Interconnection Service that allows the Interconnection Customer to connect its Generating Facility to the APS Transmission System and IID's share of the JPP to be eligible to deliver the Generating Facility's electric output using the existing firm or nonfirm capacity of the APS Transmission System and IID's share of the JPP on an as available basis. Energy Resource Interconnection Service in and of itself does not convey transmission service.

Engineering & Procurement (E&P) Agreement shall mean an agreement between NextLight and APS, on behalf of the Transmission Owners pursuant to the Participation Agreement, to begin engineering and procurement of long lead-time items necessary for the establishment of the interconnection in order to advance the implementation of the Interconnection Requests for Phase A of the Interconnection Project, which has been duly assigned to Agua Caliente Solar, LLC.

Environmental Law shall mean Applicable Laws or Regulations relating to pollution or protection of the environment or natural resources.

Federal Power Act shall mean the Federal Power Act, as amended, 16 U.S.C. §§ 791a et seq.

FERC shall mean the Federal Energy Regulatory Commission or its successor.

Force Majeure shall mean any act of God, labor disturbance, act of the public enemy, war, insurrection, riot, fire, storm or flood, earthquake, explosion, breakage or accident to machinery or equipment, any order, regulation or restriction imposed by governmental, military or lawfully established civilian authorities, or any other cause beyond a Party's control. A Force Majeure event does not include acts of negligence or intentional wrongdoing by the Party claiming Force Majeure.

Generating Facility shall mean Interconnection Customer's device for the production of electricity identified in the Interconnection Request(s), but shall not include the Interconnection Customer's Interconnection Facilities. The Generating Facility consists of Phase A of the Generating Facility and Phase B of the Generating Facility.

Generating Facility Capacity shall mean the net capacity of the Generating Facility and the aggregate net capacity of the Generating Facility where it includes multiple energy production devices.

Good Utility Practice shall mean any of the practices, methods and acts engaged in or approved by a significant portion of the electric utility industry during the relevant time period, or any of the practices, methods and acts which, in the exercise of reasonable judgment in light of the facts known at the time the decision was made, could have been expected to accomplish the desired result at a reasonable cost consistent with good business practices, reliability, safety and expedition. Good Utility Practice is not intended to be any one of a number of the optimum practices, methods, or acts to the exclusion of all others, but rather to be acceptable practices, methods, or acts generally accepted in the region.

Governmental Authority shall mean any federal, state, local or other governmental regulatory or administrative agency, court, commission, department, board, or other governmental subdivision, legislature, rulemaking board, tribunal, or other governmental authority having jurisdiction over the Parties, their respective facilities, or the respective services they provide, and exercising or entitled to exercise any administrative, executive, police, or taxing authority or power; provided, however, that such term does not include Interconnection Customer, Transmission Owners, the CAISO, or any Affiliate thereof.

Hazardous Substances shall mean any chemicals, materials or substances defined as or included in the definition of "hazardous substances," "hazardous wastes," "hazardous materials," "hazardous constituents," "restricted hazardous materials," "extremely hazardous substances," "toxic substances," "radioactive substances," "contaminants," "pollutants," "toxic pollutants" or words of similar meaning and regulatory effect under any applicable Environmental Law, or any other chemical, material or substance, exposure to which is prohibited, limited or regulated by any applicable Environmental Law.

Initial Synchronization Date shall mean the date upon which the first Project Block of a Project Phase is initially synchronized and upon which Trial Operation begins.

In-Service Date shall mean the date upon which the Interconnection Customer reasonably expects it will be ready to begin use of the Transmission Owners' Interconnection Facilities to obtain back feed power.

Interconnection Customer shall mean Agua Caliente Solar LLC, to which NextLight has duly assigned its Interconnection Requests for Phase A of the Generating Facility, and North Gila River Development, LLC, to which NextLight has duly assigned its Interconnection Request submitted only to APS for Phase B of the Generating Facility, and their successors and assigns.

Interconnection Customer's Interconnection Facilities shall mean all facilities and equipment, as identified in Appendices A-1 and A-2 of this Agreement, that are located between the Generating Facility and the Point of Change of Ownership, including any modification, addition, or upgrades to such facilities and equipment necessary to physically and electrically interconnect the Generating Facility to the JPP. Interconnection Customer's Interconnection Facilities are sole use facilities.

Interconnection Facilities shall mean the Transmission Owners' Interconnection Facilities and the Interconnection Customer's Interconnection Facilities. Collectively, Interconnection Facilities include all facilities and equipment between the Generating Facility and the Point of Interconnection, including any modification, additions or upgrades that are necessary to physically and electrically interconnect the Generating Facility to the JPP. Interconnection Facilities are sole use facilities and shall not include Distribution Upgrades, Stand Alone Network Upgrades or Network Upgrades.

Interconnection Facilities Study shall mean a study conducted by APS or a third party consultant for the Interconnection Customer to determine a list of facilities (including Transmission Owners' Interconnection Facilities and Network Upgrades to the JPP as identified in the Interconnection System Impact Study), the cost of those facilities, and the time required to interconnect the Generating Facility with the JPP; the scope of the study is defined in Section 8 of the APS Large Generator Interconnection Procedures.

Interconnection Feasibility Study shall mean a preliminary evaluation of the system impact and cost of interconnecting the Generating Facility to the JPP, the scope of which is described in Section 6 of the APS Large Generator Interconnection Procedures.

Interconnection Financial Security shall have the meaning assigned to it in Section 1.2 of the CAISO's Large Generator Interconnection Procedures.

Interconnection Request shall mean a request, in the form of Appendix 1 to the Large Generator Interconnection Procedures, in accordance with the APS or CAISO Tariffs, to interconnect a new Generating Facility, or to increase the capacity of, or make a Material Modification to the operating characteristics of, an existing Generating Facility that is interconnected with the JPP. The Interconnection Customer made an Interconnection Request to APS for both Phase A of the Generating Facility and Phase B of the Generating Facility and an Interconnection Request to the CAISO only for Phase A of the Generating Facility. The Interconnection Customer did not make an Interconnection Request to IID.

Interconnection Service shall mean the service provided by the Transmission Owners and the CAISO associated with interconnecting the Interconnection Customer's Generating Facility to the JPP and enabling them to receive electric energy and capacity from the Generating Facility at the Point of Interconnection, pursuant to the terms of this Agreement and the Tariffs of APS, IID, SDG&E, and the CAISO.

Interconnection Study shall mean any of the following studies: (1) the Interconnection Feasibility Study, the Interconnection System Impact Study, or the Interconnection Facilities Study described in the APS Large Generator Interconnection Procedures; or (2) the Phase I Interconnection Study or the Phase II Interconnection Study described in the CAISO Large Generator Interconnection Procedures.

Interconnection System Impact Study shall mean an engineering study that evaluates the impact of the proposed interconnection on the safety and reliability of Transmission Owners' Transmission Systems and, if applicable, an Affected System. The study shall identify and detail the system impacts that would result if the Generating Facility were interconnected without project modifications or system modifications, focusing on the Adverse System Impacts identified in the Interconnection Feasibility Study, or to study potential impacts, including but not limited to those identified in the Scoping Meeting as described in the APS Large Generator Interconnection Procedures.

Interconnection System Impact Study Agreement shall mean the form of agreement contained in the Large Generator Interconnection Procedures of APS for conducting an Interconnection System Impact Study.

IRS shall mean the Internal Revenue Service.

Joint Operating Committee shall be a group made up of representatives from Interconnection Customer and APS, on behalf of the Transmission Owners, to coordinate operating and technical considerations of Interconnection Service.

Joint Participation Project (JPP) shall mean the transmission facilities jointly owned by APS, IID and SDG&E pursuant to the Arizona Transmission System Participation Agreement, as amended.

Large Generating Facility shall mean a Generating Facility having a Generating Facility Capacity of more than 20 MW.

Large Generator Interconnection Procedures (LGIP) shall mean the interconnection procedures applicable to an Interconnection Request pertaining to a Large Generating Facility that are included in the APS or the CAISO Tariff. With respect to the Interconnection Request made to the CAISO for Phase A of the Generating Facility, the applicable LGIP is the LGIP for Interconnection Requests in a Queue Cluster Window, which is found in CAISO Tariff Appendix Y.

Loss shall mean any and all damages, losses and claims, including claims and actions relating to injury to or death of any person or damage to property, demand, suits, recoveries, costs and expenses, court costs, attorney fees, and all other obligations by or to third parties.

Material Modification shall mean those modifications that have a material impact on the cost or timing of any Interconnection Request or any other valid interconnection request with a later queue priority date.

Metering Equipment shall mean all metering equipment installed or to be installed for measuring the output at the Generating Facility pursuant to this Agreement at the metering points, including but not limited to instrument transformers, MWh-meters, data acquisition equipment, transducers, remote terminal unit, communications equipment, phone lines, and fiber optics.

NERC shall mean the North American Electric Reliability Corporation or its successor organization.

Network Resource shall mean any designated generating resource owned, purchased, or leased by a Network Customer under the APS Network Integration Transmission Service Tariff, or the IID Open Access Transmission Tariff. Network Resources do not include any resource, or any portion thereof, that is committed for sale to third parties or otherwise cannot be called upon to meet the Network Customer's Network Load on a non-interruptible basis.

Network Resource Interconnection Service shall mean an Interconnection Service that allows an interconnection customer to integrate its Large Generating Facility with the APS Transmission System or IID's share of the JPP in a manner comparable to that in which APS or IID integrates its generating facilities to serve native load customers. Network Resource Interconnection Service in and of itself does not convey transmission service.

Network Upgrades shall mean the additions, modifications, and upgrades to the Transmission Owners' and CAISO's Transmission Systems required at or beyond the point at which the Interconnection Facilities connect to the JPP to accommodate the interconnection of the Large Generating Facility to the Transmission Owners' and the CAISO's Transmission Systems.

Notice of Dispute shall mean a written notice of a dispute or claim that arises out of or in connection with this Agreement or its performance.

Operating Agent of the JPP shall mean APS as the entity designated as the operating agent of the JPP pursuant to the Participation Agreement.

Ownership Interests shall mean the ownership interests of APS, IID and SDG&E in the JPP, as set forth in the Participation Agreement, as amended, and for purposes of this Agreement, APS, 11 percent; IID, 12.78 percent; and SDG&E, 76.22 percent.

Party or Parties shall mean Transmission Owner(s), the CAISO, Interconnection Customer or the applicable combination of the above.

Phase I Interconnection Study shall have the meaning set forth in the CAISO Tariff as of the effective date of this Agreement.

Phase II Interconnection Study shall have the meaning set forth in the CAISO Tariff as of the effective date of this Agreement.

Phase A of the Generating Facility shall mean no more than 290 MW (net) of solar photovoltaic units installed at the site of the Generating Facility, as described in Appendix C.

Phase B of the Generating Facility shall mean no more than 210 MW (net) of solar photovoltaic units installed at the site of the Generating Facility, as described in Appendix C, after Phase A of the Generating Facility has been completed.

Phase A of the Interconnection Project shall mean construction of the Interconnection Facilities and Network Upgrades required to interconnect Phase A of the Generating Facility, as described in Appendix A-1.

Phase B of the Interconnection Project shall mean construction of the Interconnection Facilities and Network Upgrades required to interconnect Phase B of the Generating Facility, as described in Appendices A-2 and A-3 and as may be identified in studies provided for in Appendix C.

Point of Change of Ownership shall mean the point, as set forth in Appendices A-1 and A-2 to this Agreement, where the Interconnection Customer's Interconnection Facilities connect to the Transmission Owners' Interconnection Facilities.

Point of Interconnection shall mean the point, as set forth in Appendices A-1 and A-2 to this Agreement, where the Interconnection Facilities connect to the JPP.

Project Block shall mean a portion of the solar photovoltaic units within a Project Phase as described in Appendix B-1 and B-2.

Project Phase shall mean either Phase A of the Generating Facility or Phase B of the Generating Facility.

Queue Position shall mean the order of a valid Interconnection Request, relative to all other pending valid Interconnection Requests, that is established based upon the date and time of receipt of the valid Interconnection Request by APS or the CAISO under its Tariff.

Reasonable Efforts shall mean, with respect to an action required to be attempted or taken by a Party under this Agreement, efforts that are timely and consistent with Good Utility Practice and are otherwise substantially equivalent to those a Party would use to protect its own interests.

Scoping Meeting shall mean the meetings between representatives of the Interconnection Customer and Transmission Owners and the CAISO conducted for the purpose of discussing alternative interconnection options, to exchange information including any transmission data and earlier study evaluations that would be reasonably expected to impact such interconnection options, to analyze such information, and to determine the potential feasible Points of Interconnection.

Site Control shall mean documentation reasonably demonstrating: (1) ownership of, a leasehold interest in, or a right to develop a site for the purpose of constructing the Generating Facility; (2) an option to purchase or acquire a leasehold site for such purpose; or (3) an exclusivity or other business relationship between Interconnection Customer and the entity

having the right to sell, lease or grant Interconnection Customer the right to possess or occupy a site for such purpose.

Small Generating Facility shall mean a Generating Facility that has a Generating Facility Capacity of no more than 20 MW.

Stand Alone Network Upgrades shall mean Network Upgrades that an Interconnection Customer may construct without affecting day-to-day operations of the Transmission System during their construction. The Transmission Owners, the CAISO and the Interconnection Customer must agree as to what constitutes Stand Alone Network Upgrades and identify them in Appendices A-1, A-2, and A-3 to this Agreement.

System Protection Facilities shall mean the equipment, including necessary protection signal communications equipment, that protects (1) the Transmission Owners' and the CAISO's Transmission Systems from faults or other electrical disturbances occurring at the Generating Facility and (2) the Generating Facility from faults or other electrical system disturbances occurring on the Transmission Owners' and the CAISO's Transmission Systems or on other delivery systems or other generating systems to which the Transmission Owners' and the CAISO's Transmission Systems are directly connected.

Tariff shall mean the APS, IID, SDG&E or CAISO tariffs through which open access transmission service and Interconnection Service are offered, as filed with FERC with respect to FERC-jurisdictional public utilities and as posted with respect to IID, and as amended or supplemented from time to time, or any successor tariff.

Transmission Owner(s) shall mean APS, IID and SDG&E, as joint owners of the JPP at the Point of Interconnection. Pursuant to the Participation Agreement, APS is Operating Agent of the JPP and acts on behalf of the Transmission Owners with respect to the JPP.

Transmission Owners' Interconnection Facilities shall mean all facilities and equipment owned, controlled or operated by the Transmission Owners from the Point of Change of Ownership identified in Appendices A-1 and A-2 to the Point of Interconnection as identified in Appendices A-1 and A-2 to this Agreement, including any modifications, additions or upgrades to such facilities and equipment. Transmission Owners' Interconnection Facilities are sole use facilities and shall not include Distribution Upgrades, Stand Alone Network Upgrades or Network Upgrades.

Transmission System shall mean the facilities, including the portion of the JPP, owned, controlled or operated by Transmission Owner or the CAISO that are used to provide transmission service under the respective Tariff.

Trial Operation shall mean the period during which Interconnection Customer is engaged in on-site test operations and commissioning of the first Project Block of each Project Phase prior to Commercial Operation.

Article 2. Effective Date, Term, and Termination

2.1 Effective Date. Except as provided below with respect to IID, this Agreement shall become effective upon execution by the Parties and acceptance for filing by FERC, or if filed unexecuted under Section 205 of the Federal Power Act, upon the date specified by

FERC for the Transmission Owners that are FERC-jurisdictional public utilities and the CAISO. Such Transmission Owners and the CAISO shall promptly submit this Agreement for filing with FERC upon execution in accordance with Article 3.1. The Parties acknowledge that IID is not a public utility subject to FERC's jurisdiction under Section 205 or 206 of the Federal Power Act. Therefore, as applied to IID, the Effective Date for the Agreement shall not commence until the later of the date the Agreement is executed by IID, either voluntarily or pursuant to a lawful order issued by FERC in accordance with Sections 210 and 212 of the Federal Power Act, and the date the Agreement is accepted for filing with regard to the Transmission Owners that are FERC-jurisdictional and the CAISO.

2.2 Term of Agreement. Subject to the provisions of Article 2.3, this Agreement shall remain in effect for a period of forty (40) years from the Effective Date and shall be automatically renewed for each successive one-year period thereafter.

2.3 Termination Procedures.

2.3.1 Written Notice. This Agreement may be terminated by (i) Interconnection Customer after giving all other Parties ninety (90) Calendar Days advance written notice, or (ii) by APS, on behalf of the Transmission Owners, or the CAISO notifying FERC after the Generating Facility permanently ceases Commercial Operation. Notice of termination by the Interconnection Customer must be provided by both of the entities comprising the Interconnection Customer.

2.3.2 Default. A Party may terminate this Agreement in accordance with Article 17.

2.3.3 Notwithstanding Articles 2.3.1 and 2.3.2, no termination shall become effective until the Parties have complied with all Applicable Laws and Regulations applicable to such termination, including any required filing with FERC of a notice of termination of this Agreement, which notice has been accepted for filing by FERC. For clarity and avoidance of ambiguity, IID is not a jurisdictional public utility required to file a notice of termination under Section 205 or 206 of the Federal Power Act prior to terminating its participation in this Agreement in accordance with the terms of such Agreement.

2.4 Termination Costs

Upon receipt of a notice of the termination of this Agreement pursuant to Article 2.3 above, the Transmission Owners and the CAISO will promptly determine the total cost responsibility of the Interconnection Customer. If, as of the date of receipt of such notice of termination, the Interconnection Customer has not already paid its share of Network Upgrade costs, including those set forth in Appendices A-1, A-2, and A-3, APS, as the Operating Agent of the JPP, will enforce the financial security rights of APS and IID pursuant to this Agreement and SDG&E will cause Interconnection Customer's Interconnection Financial Security associated with its cost responsibility for SDG&E's non-JPP Network Upgrades and SDG&E's share of the JPP Network Upgrades set forth in Appendices A-1, A-2, and A-3 to be liquidated, in accordance with Section 9.4 of the CAISO's Large Generator Interconnection Procedures.

The Interconnection Customer will also be responsible for all costs incurred or irrevocably committed to be incurred in association with the construction of the Transmission Owners' Interconnection Facilities (including any cancellation costs relating to orders or contracts for Interconnection Facilities and equipment) and other such expenses for which the Transmission Owners or the CAISO have incurred expenses or have irrevocably committed to incur expenses and have not been reimbursed by the Interconnection Customer, as of the date of receipt of the notice of termination, subject to the limitations set forth in this Article 2.4. Nothing in this Article 2.4 shall limit the Parties' rights under Article 17. If, as of the date of the receipt of the notice of termination, the Interconnection Customer has not already reimbursed the Transmission Owners and the CAISO for costs incurred to construct the Transmission Owners' Interconnection Facilities, APS, as Operating Agent of the JPP, shall enforce the financial security rights of APS and IID pursuant to this Agreement and SDG&E will liquidate the Interconnection Customer's Interconnection Financial Security associated with the construction of SDG&E's share of the Transmission Owners' Interconnection Facilities, in accordance with Section 9.4 of the CAISO Large Generator Interconnection Procedures.

For cost responsibility for Interconnection Facilities and Network Upgrades to the JPP set forth in Appendices A-1 and A-2, the Transmission Owners' financial security rights shall be enforced in accordance with the provisions for enforcement of financial security set forth in Appendices A-1 and A-2.

If the amount of the financial security, including the Interconnection Financial Security, liquidated by Transmission Owners under this Article 2.4 is insufficient to compensate Transmission Owners and the CAISO for actual costs associated with the construction of the Transmission Owners' Interconnection Facilities and Network Upgrades contemplated in this Article, any additional amounts will be the responsibility of the Interconnection Customer. Any such additional amounts due from the Interconnection Customer beyond the amounts covered by its financial security, including its Interconnection Financial Security, will be due to the Transmission Owners immediately upon termination of this Agreement, subject, with respect to amounts due SDG&E, to the provisions of Section 9.4 of the CAISO Large Generator Interconnection Procedures.

If the amount of the Interconnection Financial Security exceeds the Interconnection Customer's cost responsibility under Section 9.4 of the CAISO's Large Generator Interconnection Procedures, such excess amount will be released to the Interconnection Customer by SDG&E in accordance with Section 9.4 of the CAISO's Large Generator Interconnection Procedures.

Notwithstanding the foregoing, in the event of termination of this Agreement, the Parties shall use commercially Reasonable Efforts to mitigate the costs, damages and charges arising as a consequence of termination. Upon termination of this Agreement, unless otherwise ordered or approved by FERC to the extent FERC possesses jurisdiction over the public utilities which are Parties to this Agreement:

2.4.1 With respect to any portion of Transmission Owners' Interconnection Facilities that have not yet been constructed or installed, Transmission Owners shall to the extent possible and with Interconnection Customer's authorization cancel any pending orders of, or return, any materials or equipment for, or contracts for

construction of, such Interconnection Facilities; provided that in the event Interconnection Customer elects not to authorize such cancellation, Interconnection Customer shall assume all payment obligations with respect to such materials, equipment, and contracts, and Transmission Owners shall deliver such material and equipment, and, if necessary, assign such contracts, to Interconnection Customer as soon as practicable, at Interconnection Customer's expense. To the extent that Interconnection Customer has already paid Transmission Owners for any or all such costs of materials or equipment not taken by Interconnection Customer, Transmission Owners shall promptly refund such amounts to Interconnection Customer, less any costs, including penalties incurred by Transmission Owners to cancel any pending orders of or return such materials, equipment, or contracts.

- 2.4.2** Transmission Owners may, at their collective option, retain any portion of such materials, equipment, or facilities that Interconnection Customer chooses not to accept delivery of, in which case Transmission Owners shall be responsible for all costs associated with procuring such materials, equipment, or facilities.
- 2.4.3** With respect to any portion of the Interconnection Facilities, and any other facilities already installed or constructed pursuant to the terms of this Agreement, Interconnection Customer shall be responsible for all costs associated with the removal, relocation or other disposition or retirement of such materials, equipment, or facilities.

- 2.5** **Disconnection.** Upon termination of this Agreement as to Phase A of the Interconnection Project, APS, on behalf of Transmission Owners, will take all appropriate steps to disconnect Phase A of the Interconnection Project from the JPP. All costs required to effectuate such disconnection shall be borne by the terminating Party, unless such termination resulted from the non-terminating Party's Default of this Agreement or such non-terminating Party otherwise is responsible for these costs under this Agreement.

Upon termination of this Agreement as to Phase B of the Interconnection Project, APS, on behalf of Transmission Owners will take all appropriate steps to disconnect Phase B of the Interconnection Project from the JPP. All costs required to effectuate such disconnection shall be borne by the terminating Party, unless such termination resulted from the non-terminating Party's Default of this Agreement or such non-terminating Party otherwise is responsible for these costs under this Agreement.

- 2.6** **Survival.** This Agreement shall continue in effect after termination to the extent necessary to provide for final billings and payments and for costs incurred hereunder, including billings and payments pursuant to this Agreement; to permit the determination and enforcement of liability and indemnification obligations arising from acts or events that occurred while this Agreement was in effect; and to permit the Parties to have access to the lands of another Party pursuant to this Agreement or other applicable agreements, to disconnect, remove or salvage its own facilities and equipment.

Article 3. Regulatory Filings

- 3.1 Filing.** The CAISO and Transmission Owners that are FERC-jurisdictional public utilities shall file this Agreement (and any amendment hereto) with the appropriate Governmental Authority, if required. Interconnection Customer may request that any information so provided be subject to the confidentiality provisions of Article 22. If Interconnection Customer has executed this Agreement, or any amendment thereto, Interconnection Customer shall reasonably cooperate with Transmission Owners and the CAISO with respect to such filing and to provide any information reasonably requested by Transmission Owners and the CAISO needed to comply with applicable regulatory requirements. For clarity and avoidance of ambiguity, IID is not a jurisdictional public utility subject to a filing requirement under Section 205 of the Federal Power Act.

Article 4. Scope of Service

- 4.1 Interconnection Product Options.** Interconnection Customer has selected Energy Resource Interconnection Service from APS to interconnect to the APS Transmission System and IID's share of the JPP, and Interconnection Service from the CAISO.

- 4.1.1 CAISO Interconnection Service.** Interconnection Service provided by the CAISO and SDG&E allows the Interconnection Customer to connect the Large Generating Facility to the CAISO's Transmission System and be eligible to deliver the Large Generating Facility's output using the available capacity of the CAISO's Transmission System pursuant to the CAISO Tariff.

Interconnection Service does not necessarily provide the Interconnection Customer with the capability to physically deliver the output of its Large Generating Facility to any particular load on the CAISO Transmission System without incurring congestion costs. In the event of transmission constraints on the CAISO Transmission System, the Interconnection Customer's Large Generating Facility shall be subject to the applicable congestion management procedures in the CAISO Tariff in the same manner as all other resources.

- 4.1.2 Energy Resource Interconnection Service.**

4.1.2.1 The Product. Energy Resource Interconnection Service from APS and IID allows Interconnection Customer to connect the Large Generating Facility to the JPP and be eligible to deliver the Large Generating Facility's output using available capacity on the existing firm or non-firm capacity of the APS Transmission System and IID's share of the JPP on an "as available" basis.

4.1.2.2 Transmission Delivery Service Implications. Under Energy Resource Interconnection Service, Interconnection Customer will be eligible to inject power from the Large Generating Facility into and deliver power across the APS Transmission System and IID's share of the JPP on an "as available" basis up to the amount of MWs identified in the applicable stability and steady state studies to the extent the upgrades initially required to qualify for Energy Resource Interconnection Service have been constructed. No transmission delivery service from the Large Generating Facility is assured, but Interconnection Customer may obtain Point-to-Point Transmission Service, Network Integration Transmission

Service, or be used for secondary network transmission service, pursuant to the APS Tariff or Transmission Service on IID's share of the JPP pursuant to the IID Tariff, up to the maximum output identified in the stability and steady state studies. In order for Interconnection Customer to obtain the right to deliver or inject energy beyond the Large Generating Facility Point of Interconnection or to improve its ability to do so, transmission delivery service must be obtained pursuant to the provisions of the APS or IID Tariffs. The Interconnection Customer's ability to inject its Large Generating Facility output beyond the Point of Interconnection, therefore, will depend on the existing capacity of the APS or IID Transmission Systems at such time as a transmission service request is made that would accommodate such delivery. The provision of firm Point-to-Point Transmission Service or Network Integration Transmission Service may require the construction of additional Network Upgrades.

4.1.3 Network Resource Interconnection Service.

4.1.3.1 The Product. [THIS SECTION IS NOT APPLICABLE TO THIS AGREEMENT.]

4.1.3.2 Transmission Delivery Service Implications. [THIS SECTION IS NOT APPLICABLE TO THIS AGREEMENT.]

4.2 Provision of Service. APS, on behalf of the Transmission Owners, and the CAISO shall provide Interconnection Service for the Large Generating Facility at the Point of Interconnection.

4.3 Performance Standards. Each Party shall perform all of its obligations under this Agreement in accordance with Applicable Laws and Regulations, Applicable Reliability Standards, and Good Utility Practice, and to the extent a Party is required or prevented or limited in taking any action by such regulations and standards, such Party shall not be deemed to be in Breach of this Agreement for its compliance therewith. If such Party is a Transmission Owner or the CAISO, then that Party shall negotiate an amendment to the Agreement and, if it is a FERC-jurisdictional public utility, shall submit the amendment to FERC for approval. For clarity and avoidance of ambiguity, IID is not a FERC-jurisdictional public utility subject to a filing requirement under Section 205 of the Federal Power Act.

4.4 No Transmission Delivery Service. The execution of this Agreement does not constitute a request for, nor the provision of, any transmission delivery service under any applicable Tariff, and does not convey any right to deliver electricity to any specific customer or point of delivery.

4.5 Interconnection Customer Provided Services. The services provided by Interconnection Customer under this Agreement are set forth in Article 9.6 and Article 13.5.1. Interconnection Customer shall be paid for such services in accordance with Article 11.6.

Article 5. Interconnection Facilities Engineering, Procurement, and Construction

5.1 Options. Unless otherwise mutually agreed to between the Parties, Interconnection Customer shall select the In-Service Date, Initial Synchronization Date, and Commercial Operation Date; and either Standard Option or Alternate Option set forth below for completion of Transmission Owners' Interconnection Facilities and Network Upgrades as set forth in Appendices A-1, A-2, and A-3, and such dates and selected option shall be set forth in Appendices B-1, B-2, and B-3 Milestones.

5.1.1 Standard Option. APS, on behalf of Transmission Owners shall design, procure, and construct Transmission Owners' Interconnection Facilities and JPP Network Upgrades set forth in Appendices A-1 and A-2, and SDG&E shall design, procure, and construct Network Upgrades set forth in Appendix A-3, in each case using Reasonable Efforts to complete the Transmission Owners' Interconnection Facilities and these Network Upgrades by the dates set forth in Appendices B-1, B-2, and B-3 Milestones. Transmission Owners shall not be required to undertake any action which is inconsistent with their standard safety practices, material and equipment specifications, design criteria and construction procedures, labor agreements, and Applicable Laws and Regulations. In the event APS, on behalf of Transmission Owners, and/or SDG&E, as applicable, reasonably expect that they will not be able to complete Transmission Owners' Interconnection Facilities and Network Upgrades set forth in Appendices A-1, A-2, and A-3 by the specified dates in the Appendices B-1, B-2, and B-3 Milestones, APS, on behalf of Transmission Owners, and/or SDG&E, as applicable, shall promptly provide written notice to Interconnection Customer and shall undertake Reasonable Efforts to meet the earliest dates thereafter.

5.1.2 Alternate Option. [THIS SECTION IS NOT APPLICABLE TO THIS AGREEMENT.]

5.1.3 Option to Build. [THIS SECTION IS NOT APPLICABLE TO THIS AGREEMENT.]

5.1.4 Negotiated Option. [THIS SECTION IS NOT APPLICABLE TO THIS AGREEMENT.]

5.2 General Conditions Applicable to Option to Build. [THIS SECTION IS NOT APPLICABLE TO THIS AGREEMENT.]

5.3 Liquidated Damages. [THIS SECTION IS NOT APPLICABLE TO THIS AGREEMENT.]

5.4 Power System Stabilizers. If the Applicable Reliability Standards, or the guidelines and procedures established by the Applicable Reliability Council, deem a Power System Stabilizer applicable to the type of solar photovoltaic equipment used in the Generating Facility, then the Interconnection Customer shall procure, install, maintain and operate Power System Stabilizers. APS reserves the right to reasonably establish minimum acceptable settings for any installed Power System Stabilizers, subject to the design and operating limitations of the Large Generating Facility. If the Large Generating Facility's Power System Stabilizers are removed from service or not capable of automatic operation, Interconnection Customer shall immediately notify APS and restore the Power

System Stabilizers to operation as soon as possible. APS shall have the right to order the reduction in output or disconnection of the Large Generating Facility if the reliability of the Transmission System would be adversely affected as a result of improperly tuned Power System Stabilizers. The Generating Facility is a solar photovoltaic generator and as such does not have the physical characteristic to which a Power System Stabilizer would apply.

- 5.5 Equipment Procurement.** The Transmission Owners' design of Transmission Owners' Interconnection Facilities and Network Upgrades to the JPP for Phase A of the Interconnection Project, as set forth in Appendix A-1, and partial procurement of certain long-lead equipment for Phase A of the Interconnection Project has been advanced in accordance with the terms of the E & P Agreement dated March 30, 2010. To the extent the design and long lead time procurement work has not been completed pursuant to the E&P Agreement, APS, on behalf of Transmission Owners, shall finish design of Transmission Owners' Interconnection Facilities and Network Upgrades to the JPP and procure necessary equipment pursuant to the terms of this Agreement.
- 5.6 Construction Commencement.** APS, on behalf of Transmission Owners, shall commence construction of Transmission Owners' Interconnection Facilities and Network Upgrades to the JPP for which it is responsible as set forth in Appendices A-1, and A-2, and SDG&E shall commence construction of Network Upgrades to its non-JPP facilities for which it is responsible as set forth in Appendix A-3, as soon as practicable after the following additional conditions are satisfied:
- 5.6.1** Approval of the appropriate Governmental Authority has been obtained for any facilities requiring regulatory approval;
 - 5.6.2** Necessary real property rights and rights-of-way have been obtained, to the extent required for the construction of a discrete aspect of Transmission Owners' Interconnection Facilities and Network Upgrades set forth in Appendices A-1, A-2, and A-3;
 - 5.6.3** Transmission Owners have received written authorization to proceed with construction from Interconnection Customer by the date specified in Appendices B-1, B-2, and B-3 Milestones; and
 - 5.6.4** Interconnection Customer has provided payment and security in accordance with Article 11.5 by the dates specified in Appendices B-1, B-2, and B-3, Milestones.
 - 5.6.5** For Phase B of the Interconnection Project only, the conditions specified in Appendix C also shall be met before construction of Transmission Owners' Interconnection Facilities and Network Upgrades commences for that Project Phase.
- 5.7 Work Progress.** The Parties will keep each other advised periodically as to the progress of their respective design, procurement and construction efforts. Any Party may, at any time, request a progress report from another Party. If, at any time, Interconnection Customer determines that the completion of Transmission Owners' Interconnection Facilities will not be required until after the specified In-Service Date, Interconnection Customer will provide written notice to APS, SDG&E, IID, and the CAISO of such later

date upon which the completion of Transmission Owners' Interconnection Facilities will be required.

- 5.8 Information Exchange.** As soon as reasonably practicable after the Effective Date, Transmission Owners, CAISO and the Interconnection Customer shall exchange information regarding the design and compatibility of the Parties' Interconnection Facilities and compatibility of the Interconnection Facilities with Transmission Owners' and the CAISO's Transmission Systems, and shall work diligently and in good faith to make any necessary design changes.
- 5.9 Limited Operation.** If any of Transmission Owners' Interconnection Facilities or Network Upgrades are not reasonably expected to be completed prior to the Commercial Operation Date of a Project Phase, Transmission Owners and CAISO shall, upon the request and at the expense of Interconnection Customer, perform operating studies on a timely basis to determine the extent to which the Large Generating Facility and Interconnection Customer's Interconnection Facilities may operate prior to the completion of Transmission Owners' Interconnection Facilities or Network Upgrades consistent with Applicable Laws and Regulations, Applicable Reliability Standards, Good Utility Practice, and this Agreement. Transmission Owners and CAISO shall permit Interconnection Customer to operate the Project Phase and Interconnection Customer's Interconnection Facilities in accordance with the results of such studies.
- 5.10 Interconnection Customer's Interconnection Facilities ('ICIF').** Interconnection Customer shall, at its expense, design, procure, construct, own and install the ICIF, as set forth in Appendices A-1 and A-2.
- 5.10.1 Interconnection Customer's Interconnection Facility Specifications.** Interconnection Customer shall submit initial specifications for the ICIF and a Project Phase, including System Protection Facilities, to (i) APS, on behalf of Transmission Owners, and (ii) CAISO at least one hundred eighty (180) Calendar Days prior to the Initial Synchronization Date for the Project Phase; and final specifications for review and comment at least ninety (90) Calendar Days prior to the Initial Synchronization Date for the Project Phase. Transmission Owners and CAISO shall review such specifications to ensure that the ICIF and Project Phase of Large Generating Facility are compatible with the technical specifications, operational control, and safety requirements of Transmission Owners and CAISO and comment on such specifications within thirty (30) Calendar Days of Interconnection Customer's submission. All specifications provided hereunder shall be deemed confidential.
- 5.10.2 Review by Transmission Owners and CAISO.** Transmission Owners and CAISO review of Interconnection Customer's final specifications shall not be construed as confirming, endorsing, or providing a warranty as to the design, fitness, safety, durability or reliability of the Large Generating Facility, or the ICIF. Interconnection Customer shall make such changes to the ICIF as may reasonably be required by Transmission Owners or CAISO, in accordance with Good Utility Practice, to ensure that the ICIF are compatible with the technical specifications, operational control, and safety requirements of Transmission Owners and CAISO.

5.10.3 ICIF Construction. The ICIF shall be designed and constructed in accordance with Good Utility Practice. Within one hundred twenty (120) Calendar Days after the Commercial Operation Date of a Project Phase, unless the Parties agree on another mutually acceptable deadline, Interconnection Customer shall deliver to (i) APS, on behalf of Transmission Owners, and (ii) CAISO “as-built” drawings, information and documents for the ICIF and the applicable Project Phase of the Large Generating Facility, such as: a one-line diagram, a site plan showing the Large Generating Facility and the ICIF, plan and elevation drawings showing the layout of the ICIF, a relay functional diagram, relaying AC and DC schematic wiring diagrams and relay settings for all facilities associated with Interconnection Customer’s step-up transformers, the facilities connecting the Project Phase to the step-up transformers and the ICIF, and the impedances (determined by factory tests) for the associated step-up transformers and the Project Phase. The Interconnection Customer shall provide (i) APS, on behalf of Transmission Owners, and (ii) CAISO specifications for the excitation system, automatic voltage regulator, Large Generating Facility control and protection settings, transformer tap settings, and communications, if applicable. Any deviations from the relay settings, machine specifications, and other specifications originally submitted by the Interconnection Customer shall be assessed by the Transmission Owners and the CAISO pursuant to the appropriate provisions of this Agreement and the APS and CAISO Large Generator Interconnection Procedures.

5.11 Transmission Owners’ Interconnection Facilities Construction. Transmission Owners’ Interconnection Facilities shall be designed and constructed in accordance with Good Utility Practice. Upon request, within one hundred twenty (120) Calendar Days after the Commercial Operation Date, unless the Parties agree on another mutually acceptable deadline, APS, on behalf of Transmission Owners, shall deliver to Interconnection Customer and the CAISO the “as-built” drawings, information and documents for Transmission Owners’ Interconnection Facilities, including appropriate drawings and relay diagrams.

APS, on behalf of Transmission Owners, will obtain control of Transmission Owners’ Interconnection Facilities and Stand Alone Network Upgrades to the JPP upon completion of such facilities.

5.12 Access Rights. Upon reasonable notice and supervision by a Party, and subject to any required or necessary regulatory approvals, a Party (“Granting Party”) shall furnish at no cost to the other Party (“Access Party”) any rights of use, licenses, rights of way and easements with respect to lands owned or controlled by the Granting Party, its agents (if allowed under the applicable agency agreement), or any Affiliate, that are necessary to enable the Access Party to obtain ingress and egress to construct, operate, maintain, repair, test (or witness testing), inspect, replace or remove facilities and equipment to: (i) interconnect the Large Generating Facility with the JPP; (ii) operate and maintain the Large Generating Facility, the Interconnection Facilities and the JPP; and (iii) disconnect or remove the Access Party’s facilities and equipment upon termination of this Agreement. In exercising such licenses, rights of way and easements, the Access Party shall not unreasonably disrupt or interfere with normal operation of the Granting Party’s business and shall adhere to the safety rules and procedures established in advance, as

may be changed from time to time, by the Granting Party and provided to the Access Party.

- 5.13 Lands of Other Property Owners.** If any part of Transmission Owners' Interconnection Facilities and/or Network Upgrades is to be installed on property owned by persons other than Interconnection Customer or Transmission Owners, Transmission Owners shall at Interconnection Customer's expense use efforts, similar in nature and extent to those that they typically undertake on their own behalf or on behalf of their Affiliates, including use of eminent domain authority, and to the extent consistent with state law, to procure from such persons any rights of use, licenses, rights of way and easements that are necessary to construct, operate, maintain, test, inspect, replace or remove Transmission Owners' Interconnection Facilities and/or Network Upgrades upon such property.
- 5.14 Permits.** Transmission Owners and Interconnection Customer shall cooperate with each other in good faith in obtaining all permits, licenses, and authorizations that are necessary to accomplish the interconnection in compliance with Applicable Laws and Regulations. With respect to this paragraph, Transmission Owners shall provide permitting assistance to Interconnection Customer comparable to that provided to Transmission Owners' own, or an Affiliate's generation.
- 5.15 Early Construction of Base Case Facilities.** Interconnection Customer may request Transmission Owners to construct, and Transmission Owners shall construct, using Reasonable Efforts to accommodate Interconnection Customer's In-Service Date, all or any portion of any Network Upgrades required for Interconnection Customer to be interconnected to the JPP which are included in the Base Case of the Interconnection Facilities Study for Interconnection Customer, and which also are required to be constructed for another interconnection customer, but where such construction is not scheduled to be completed in time to achieve Interconnection Customer's In-Service Date.
- 5.16 Suspension.** Interconnection Customer reserves the right, upon written notice to APS, SDG&E, IID and the CAISO, to suspend at any time all work by APS and SDG&E associated with the construction and installation of Transmission Owners' Interconnection Facilities and/or Network Upgrades required under this Agreement, other than Network Upgrades, if any, identified in the Phase II Interconnection Study under the CAISO's Large Generator Interconnection Procedures as common to multiple Generating Facilities, with the condition that the Transmission System shall be left in a safe and reliable condition in accordance with Good Utility Practice and Transmission Owners' safety and reliability criteria, and the Applicable Reliability Standards. In such event, Interconnection Customer shall be responsible for all reasonable and necessary costs which Transmission Owners, (i) have incurred pursuant to this Agreement prior to the suspension and (ii) incur in suspending such work, including any costs incurred to perform such work as may be necessary to ensure the safety of persons and property and the integrity of the Transmission System during such suspension and, if applicable, any costs incurred in connection with the cancellation or suspension of material, equipment and labor contracts which Transmission Owners cannot reasonably avoid; provided, however, that prior to canceling or suspending any such material, equipment or labor contract, Transmission Owners shall obtain Interconnection Customer's authorization to do so.

APS, on behalf of Transmission Owners, with respect to facilities identified on Appendices A-1 and A-2, and SDG&E with respect to facilities identified on Appendix A-3, shall invoice Interconnection Customer for such costs pursuant to Article 12 and shall use due diligence to minimize such costs. In the event Interconnection Customer suspends work required under this Agreement pursuant to this Article 5.16, and has not requested APS, on behalf of Transmission Owners, or SDG&E to recommence the work or has not itself recommenced work required under this Agreement in time to ensure that Commercial Operation of the full Generating Facility Capacity of the Large Generating Facility is no more than three (3) years from the final Commercial Operation Date identified in Appendices B-1, B-2, and B-3, this Agreement shall be deemed terminated and the Interconnection Customer's responsibility for costs of the Transmission Owners' Interconnection Facilities and Network Upgrades set forth in Appendices A-1, A-2, and A-3 will be determined in accordance with Article 2.4. The suspension shall begin on the date the suspension is requested, or the date of the written notice to APS, on behalf of Transmission Owners, for its work or SDG&E for its work, if no effective date is specified other than Network Upgrades, if any, identified in the Phase II Interconnection Study under the CAISO's Large Generator Interconnection Procedures.

5.17 Taxes.

5.17.1 Interconnection Customer Payments Not Taxable. The Parties intend that all payments or property transfers made by Interconnection Customer to Transmission Owners for the installation of Transmission Owners' Interconnection Facilities and the Network Upgrades shall be non-taxable, either as contributions to capital, or as a refundable advance, in accordance with the Internal Revenue Code and any applicable state income tax laws and shall not be taxable as contributions in aid of construction or otherwise under the Internal Revenue Code and any applicable state income tax laws.

5.17.2 Representations and Covenants. In accordance with IRS Notice 2001-82 and IRS Notice 88-129, Interconnection Customer represents and covenants that (i) ownership of the electricity generated at the Large Generating Facility will pass to another party prior to the transmission of the electricity on a Transmission System, (ii) for income tax purposes, the amount of any payments and the cost of any property transferred to Transmission Owners for Transmission Owners' Interconnection Facilities will be capitalized by Interconnection Customer as an intangible asset and recovered using the straight-line method over a useful life of twenty (20) years, and (iii) any portion of Transmission Owners' Interconnection Facilities that is a "dual-use intertie," within the meaning of IRS Notice 88-129, is reasonably expected to carry only a de minimis amount of electricity in the direction of the Large Generating Facility. For this purpose, "de minimis amount" means no more than 5 percent of the total power flows in both directions, calculated in accordance with the "5 percent test" set forth in IRS Notice 88-129. This is not intended to be an exclusive list of the relevant conditions that must be met to conform to IRS requirements for non-taxable treatment.

At a Transmission Owner's request, Interconnection Customer shall provide such Transmission Owner with a report from an independent engineer confirming its

representation in clause (iii), above. Transmission Owners represents and covenant that the cost of Transmission Owners' Interconnection Facilities paid for by Interconnection Customer will have no net effect on the base upon which rates are determined.

5.17.3 Indemnification for the Cost Consequences of Current Tax Liability Imposed Upon the Transmission Owner. Notwithstanding Article 5.17.1, Interconnection Customer shall protect, indemnify and hold harmless each Transmission Owner from the cost consequences of any current tax liability imposed against a Transmission Owner as the result of payments or property transfers made by Interconnection Customer to a Transmission Owner under this Agreement for Interconnection Facilities, as well as any interest and penalties, other than interest and penalties attributable to any delay caused by a Transmission Owner.

Transmission Owner shall not include a gross-up for the cost consequences of any current tax liability in the amounts it charges Interconnection Customer under this Agreement unless (i) Transmission Owner has determined, in good faith, that the payments or property transfers made by Interconnection Customer to Transmission Owner should be reported as income subject to taxation or (ii) any Governmental Authority directs Transmission Owner to report payments or property as income subject to taxation; provided, however, that Transmission Owner may require Interconnection Customer to provide security for Interconnection Facilities, in a form reasonably acceptable to Transmission Owner, in an amount equal to the cost consequences of any current tax liability under this Article 5.17. Interconnection Customer shall reimburse Transmission Owner for such costs on a fully grossed-up basis, in accordance with Article 5.17.4, within thirty (30) Calendar Days of receiving written notification from Transmission Owner of the amount due, including detail about how the amount was calculated.

The indemnification obligation shall terminate at the earlier of (1) the expiration of the ten year testing period and the applicable statute of limitation, as it may be extended by Transmission Owner upon request of the IRS, to keep these years open for audit or adjustment, or (2) the occurrence of a subsequent taxable event and the payment of any related indemnification obligations as contemplated by this Article 5.17.

5.17.4 Tax Gross-Up Amount. Interconnection Customer's liability for the cost consequences of any current tax liability under this Article 5.17 shall be calculated on a fully grossed-up basis. Except as may otherwise be agreed to by the parties, this means that Interconnection Customer will pay Transmission Owner, in addition to the amount paid for the Interconnection Facilities and Network Upgrades, an amount equal to (1) the current taxes imposed on Transmission Owner ("Current Taxes") on the excess of (a) the gross income realized by Transmission Owner as a result of payments or property transfers made by Interconnection Customer to Transmission Owner under this Agreement (without regard to any payments under this Article 5.17) (the "Gross Income Amount") over (b) the present value of future tax deductions for depreciation that will be available as a result of such payments or property transfers (the "Present

Value Depreciation Amount”), plus (2) an additional amount sufficient to permit Transmission Owner to receive and retain, after the payment of all Current Taxes, an amount equal to the net amount described in clause (1).

For this purpose, (i) Current Taxes shall be computed based on Transmission Owner’s composite federal and state tax rates at the time the payments or property transfers are received and Transmission Owner will be treated as being subject to tax at the highest marginal rates in effect at that time (the “Current Tax Rate”), and (ii) the Present Value Depreciation Amount shall be computed by discounting Transmission Owner’s anticipated tax depreciation deductions as a result of such payments or property transfers by Transmission Owner’s current weighted average cost of capital. Thus, the formula for calculating Interconnection Customer’s liability to each respective Transmission Owner pursuant to this Article 5.17.4 can be expressed as follows: $(\text{Current Tax Rate} \times (\text{Gross Income Amount} - \text{Present Value of Tax Depreciation})) / (1 - \text{Current Tax Rate})$. Interconnection Customer’s estimated tax liability in the event taxes are imposed shall be stated in Appendices A-1, A-2, and A-3.

5.17.5 Private Letter Ruling or Change or Clarification of Law. At Interconnection Customer’s request and expense, Transmission Owner shall file with the IRS a request for a private letter ruling as to whether any property transferred or sums paid, or to be paid, by Interconnection Customer to Transmission Owner under this Agreement are subject to federal income taxation. Interconnection Customer will prepare the initial draft of the request for a private letter ruling, and will certify under penalties of perjury that all facts represented in such request are true and accurate to the best of Interconnection Customer’s knowledge. Transmission Owner and Interconnection Customer shall cooperate in good faith with respect to the submission of such request.

Transmission Owner shall keep Interconnection Customer fully informed of the status of such request for a private letter ruling and shall execute either a privacy act waiver or a limited power of attorney, in a form acceptable to the IRS, that authorizes Interconnection Customer to participate in all discussions with the IRS regarding such request for a private letter ruling. Transmission Owner shall allow Interconnection Customer to attend all meetings with IRS officials about the request and shall permit Interconnection Customer to prepare the initial drafts of any follow-up letters in connection with the request.

5.17.6 Subsequent Taxable Events. If, within 10 years from the date on which the relevant Transmission Owner’s Interconnection Facilities are placed in service, (i) Interconnection Customer Breaches the covenants contained in Article 5.17.2, (ii) a “disqualification event” occurs within the meaning of IRS Notice 88-129, or (iii) this Agreement terminates and Transmission Owner retains ownership of the Interconnection Facilities and Network Upgrades, Interconnection Customer shall pay a tax gross-up for the cost consequences of any current tax liability imposed on Transmission Owner, calculated using the methodology described in Article 5.17.4 and in accordance with IRS Notice 90-60.

5.17.7 Contests. In the event any Governmental Authority determines that a Transmission Owner’s receipt of payments or property constitutes income that is

subject to taxation, such Transmission Owner shall notify Interconnection Customer, in writing, within thirty (30) Calendar Days of receiving notification of such determination by a Governmental Authority. Upon the timely written request by Interconnection Customer and at Interconnection Customer's sole expense, such Transmission Owner may appeal, protest, seek abatement of, or otherwise oppose such determination. Upon Interconnection Customer's written request and sole expense, such Transmission Owner may file a claim for refund with respect to any taxes paid under this Article 5.17, whether or not it has received such a determination. Such Transmission Owner reserves the right to make all decisions with regard to the prosecution of such appeal, protest, abatement or other contest, including the selection of counsel and compromise or settlement of the claim, but such Transmission Owner shall keep Interconnection Customer informed, shall consider in good faith suggestions from Interconnection Customer about the conduct of the contest, and shall reasonably permit Interconnection Customer or an Interconnection Customer representative to attend contest proceedings.

Interconnection Customer shall pay to such Transmission Owner on a periodic basis, as invoiced by Transmission Owner, Transmission Owner's documented reasonable costs of prosecuting such appeal, protest, abatement or other contest. At any time during the contest, such Transmission Owner may agree to a settlement either with Interconnection Customer's consent or after obtaining written advice from nationally-recognized tax counsel, selected by such Transmission Owner, but reasonably acceptable to Interconnection Customer, that the proposed settlement represents a reasonable settlement given the hazards of litigation. Interconnection Customer's obligation shall be based on the amount of the settlement agreed to by Interconnection Customer, or if a higher amount, so much of the settlement that is supported by the written advice from nationally-recognized tax counsel selected under the terms of the preceding sentence. The settlement amount shall be calculated on a fully grossed-up basis to cover any related cost consequences of the current tax liability. Any settlement without Interconnection Customer's consent or such written advice will relieve Interconnection Customer from any obligation to indemnify such Transmission Owner for the tax at issue in the contest.

5.17.8 Refund. In the event that (a) a private letter ruling is issued to a Transmission Owner which holds that any amount paid or the value of any property transferred by Interconnection Customer to such Transmission Owner under the terms of this Agreement is not subject to federal income taxation, (b) any legislative change or administrative announcement, notice, ruling or other determination makes it reasonably clear to such Transmission Owner in good faith that any amount paid or the value of any property transferred by Interconnection Customer to such Transmission Owner under the terms of this Agreement is not taxable to such Transmission Owner, (c) any abatement, appeal, protest, or other contest results in a determination that any payments or transfers made by Interconnection Customer to such Transmission Owner are not subject to federal income tax, or (d) if such Transmission Owner receives a refund from any taxing authority for any overpayment of tax attributable to any payment or property transfer made by Interconnection Customer to such Transmission Owner

pursuant to this Agreement, such Transmission Owner shall promptly refund to Interconnection Customer the following:

(i) any payment made by Interconnection Customer under this Article 5.17 to such Transmission Owner for taxes that is attributable to the amount determined to be non-taxable, together with interest thereon,

(ii) interest on any amount paid by Interconnection Customer to such Transmission Owner for such taxes which Transmission Owner did not submit to the taxing authority, calculated in accordance with the methodology set forth in FERC's regulations at 18 CFR §35.19a(a)(2)(iii) from the date payment was made by Interconnection Customer to the date such Transmission Owner refunds such payment to Interconnection Customer, and

(iii) with respect to any such taxes paid by such Transmission Owner, any refund or credit such Transmission Owner receives or to which it may be entitled from any Governmental Authority, interest (or that portion thereof attributable to the payment described in clause (i), above) owed to such Transmission Owner for such overpayment of taxes (including any reduction in interest otherwise payable by such Transmission Owner to any Governmental Authority resulting from an offset or credit); provided, however, that such Transmission Owner will remit such amount promptly to Interconnection Customer only after and to the extent that such Transmission Owner has received a tax refund, credit or offset from any Governmental Authority for any applicable overpayment of income tax related to such Transmission Owner's Interconnection Facilities.

The intent of this provision is to leave the Parties, to the extent practicable, in the event that no taxes are due with respect to any payment for Transmission Owners' Interconnection Facilities and Network Upgrades hereunder, in the same position they would have been in had no such tax payments been made.

5.17.9 Taxes Other Than Income Taxes. Upon the timely request by Interconnection Customer, and at Interconnection Customer's sole expense, Transmission Owner or the CAISO may appeal, protest, seek abatement of, or otherwise contest any tax (other than federal or state income tax) asserted or assessed against Transmission Owner or the CAISO for which Interconnection Customer may be required to reimburse Transmission Owner or the CAISO under the terms of this Agreement. Interconnection Customer shall pay to Transmission Owner on a periodic basis, as invoiced by Transmission Owner, Transmission Owners' documented reasonable costs of prosecuting such appeal, protest, abatement, or other contest. Interconnection Customer, Transmission Owner and the CAISO if applicable, shall cooperate in good faith with respect to any such contest. Unless the payment of such taxes is a prerequisite to an appeal or abatement or cannot be deferred, no amount shall be payable by Interconnection Customer to Transmission Owner or the CAISO for such taxes until they are assessed by a final, non-appealable order by any court or agency of competent jurisdiction. In the event that a tax payment is withheld and ultimately due and payable after

appeal, Interconnection Customer will be responsible for all taxes, interest and penalties, other than penalties attributable to any delay caused by Transmission Owner or the CAISO.

5.18 Tax Status. Each Party shall cooperate with the others to maintain the other Parties' tax status. Nothing in this Agreement is intended to adversely affect any Transmission Owner's or the CAISO's tax exempt status with respect to the issuance of bonds including, but not limited to, Local Furnishing Bonds.

5.19 Modification.

5.19.1 General. The Interconnection Customer or the Transmission Owners may undertake modifications to their respective facilities, subject to the provisions of this Agreement and any applicable provisions of any applicable Tariff. If either the Interconnection Customer on the one hand, or Transmission Owners on the other hand, plan to undertake a modification that reasonably may be expected to affect the other's facilities, the Party planning the modification shall provide to the other Parties sufficient information regarding such modification so that the other Parties may evaluate the potential impact of such modification prior to commencement of the work or implementation of the modification. Such information shall be deemed to be confidential hereunder and shall include information concerning the timing of such modifications and whether such modifications are expected to interrupt the flow of electricity from the Large Generating Facility. The Party desiring to perform such work or implement the modification shall provide the relevant drawings, plans, and specifications to the other Parties at least ninety (90) Calendar Days in advance of the commencement of the work or implementation of the modification or such shorter period upon which the Parties may agree, which agreement shall not unreasonably be withheld, conditioned or delayed.

In the case of Large Generating Facility modifications that do not require Interconnection Customer to submit an Interconnection Request, Transmission Owners and the CAISO shall provide, within thirty (30) Calendar Days (or such other time as the Parties may agree), an estimate of any additional modifications to the Transmission Systems, Transmission Owners' Interconnection Facilities or Network Upgrades necessitated by such Interconnection Customer modification and a good faith estimate of the costs thereof. The Transmission Owners and the CAISO shall each determine if a Large Generating Facility modification is a Material Modification in accordance with their respective Large Generator Interconnection Procedures.

Notwithstanding anything in this Agreement to the contrary, any modification to the Large Generating Facility or the terms upon which Interconnection Service is provided hereunder that requires additional facilities beyond or in lieu of those facilities specifically identified in Appendices A-1, A-2, and A-3, including but not limited to additional Transmission Owners' Interconnection Facilities or Network Upgrades, shall be dealt with in a separate Large Generator Interconnection Agreement or in an amendment to this Agreement agreed to by all Parties; provided, however, that to the extent IID determines the modification

requires additional non-JPP facilities owned by IID, such change may be dealt with in a separate Affected System Study Agreement and/or Affected System Construction and Operation Agreement.

5.19.2 Standards. Any additions, modifications, or replacements made to the Transmission Systems or Transmission Owners' Interconnection Facilities that may reasonably be expected to affect the Generating Facility or Interconnection Facilities shall be designed, constructed and operated in accordance with this Agreement, Applicable Reliability Standards, and Good Utility Practice. Any additions, modifications, or replacements made to the Generating Facility or Interconnection Customer's Interconnection Facilities that may reasonably be expected to affect the Transmission Systems or Transmission Owners' Interconnection Facilities shall be designed, constructed and operated in accordance with this Agreement, Applicable Reliability Standards, and Good Utility Practice.

5.19.3 Modification Costs. Interconnection Customer shall not be directly assigned for the costs of any additions, modifications, or replacements that Transmission Owners make to Transmission Owners' Interconnection Facilities or to each respective Transmission Owner's Transmission System to facilitate the interconnection of a third party to Transmission Owners' Interconnection Facilities or the applicable Transmission Owner's Transmission System, or to provide transmission service to a third party under the applicable Tariff, *i.e.*, APS, IID and the CAISO. Interconnection Customer shall be responsible for the costs of any additions, modifications, or replacements to Interconnection Facilities that may be necessary to maintain or upgrade such Interconnection Facilities consistent with Applicable Laws and Regulations, Applicable Reliability Standards or Good Utility Practice.

Article 6. Testing and Inspection

6.1 Pre-Commercial Operation Date Testing and Modifications. Prior to the Commercial Operation Date, APS, on behalf of Transmission Owners, shall test Transmission Owners' Interconnection Facilities and Network Upgrades to the JPP in Appendices A-1 and A-2, and SDG&E shall test Network Upgrades to its non-JPP facilities in Appendix A-3. To the extent that the Affected System Study performed by IID identifies the need to install or construct any Network Upgrades to non-JPP facilities owned by IID, then IID shall test such Network Upgrades to non-JPP facilities prior to the Commercial Operation Date and Interconnection Customer shall test the Large Generating Facility and Interconnection Customer's Interconnection Facilities to ensure their safe and reliable operation. Similar testing may be required after initial operation. APS, on behalf of Transmission Owners, SDG&E, IID, and the Interconnection Customer shall make any modifications to their respective facilities that are found to be necessary as a result of such testing. The Interconnection Customer shall bear the cost of all such testing and modifications. The Interconnection Customer shall not commence initial parallel operation of the first Project Block for Phase A of the Generating Facility or the first Project Block of Phase B of the Generating Facility with the Transmission System until the Transmission Owners provide prior written approval, which shall not be unreasonably withheld, for operation of such Project Phase. Interconnection Customer shall generate

test energy at the Large Generating Facility only if it has arranged for the delivery of such test energy.

- 6.2 Post-Commercial Operation Date Testing and Modifications.** As between Transmission Owners for the JPP facilities in Appendices A-1 and A-2, SDG&E for its non-JPP facilities in Appendix A-3, and IID for its non-JPP facilities, if any are identified in the Affected System Study, respectively, and Interconnection Customer, each Party shall at its own expense perform routine inspection and testing of its facilities and equipment in accordance with Good Utility Practice as may be necessary to ensure the continued interconnection of the Large Generating Facility with the JPP in a safe and reliable manner. As between Transmission Owners for the JPP facilities in Appendices A-1 and A-2, SDG&E for its non-JPP facilities in Appendix A-3, and IID for its non-JPP facilities, if any are identified in the Affected System Study, respectively, and Interconnection Customer, each Party shall have the right, upon advance written notice, to require reasonable additional testing of the other Party's facilities, at the requesting Party's expense, as may be in accordance with Good Utility Practice.
- 6.3 Right to Observe Testing.** Each Party shall notify the other Parties at least fourteen (14) Calendar Days in advance of its performance of tests of its Interconnection Facilities or Generating Facility. The other Parties have the right, at their own expense, to observe such testing.
- 6.4 Right to Inspect.** Each Party shall have the right, but shall have no obligation to: (i) observe another Party's tests and/or inspection of any of its System Protection Facilities and other protective equipment, including Power System Stabilizers; (ii) review the settings of another Party's System Protection Facilities and other protective equipment; and (iii) review another Party's maintenance records relative to the Interconnection Facilities, the System Protection Facilities and other protective equipment. A Party may exercise these rights from time to time as it deems necessary upon reasonable notice to the other Party. The exercise or non-exercise by a Party of any such rights shall not be construed as an endorsement or confirmation of any element or condition of the Interconnection Facilities or the System Protection Facilities or other protective equipment or the operation thereof, or as a warranty as to the fitness, safety, desirability, or reliability of same. Any information that a Party obtains through the exercise of any of its rights under this Article 6.4 shall be deemed to be Confidential Information and treated pursuant to Article 22 of this Agreement.

Article 7. Metering

- 7.1 General.** Each Party shall comply with any Applicable Reliability Standards and the Applicable Reliability Council requirements. Unless otherwise agreed by the Parties, APS, on behalf of Transmission Owners, shall install Metering Equipment at the Point of Interconnection prior to any operation of the Large Generating Facility and shall own, operate, test and maintain such Metering Equipment. Power flows to and from the Large Generating Facility shall be measured at or, at Transmission Owners' option, compensated to, the Point of Interconnection. APS, on behalf of Transmission Owners, shall provide metering quantities, in analog and/or digital form, to Interconnection Customer upon request. Interconnection Customer shall bear all reasonable documented costs associated with the purchase, installation, operation, testing and maintenance of the Metering Equipment.

- 7.2 Check Meters.** Interconnection Customer, at its option and expense, may install and operate, on its premises and on its side of the Point of Interconnection, one or more check meters to check Transmission Owners' meters. Such check meters shall be for check purposes only and shall not be used for the measurement of power flows for purposes of this Agreement, except as provided in Article 7.4 below. The check meters shall be subject at all reasonable times to inspection and examination by APS, on behalf of Transmission Owners, or its designee. The installation, operation and maintenance thereof shall be performed entirely by Interconnection Customer in accordance with Good Utility Practice.
- 7.3 Standards.** APS, on behalf of Transmission Owners, shall install, calibrate, and test revenue quality Metering Equipment in accordance with applicable ANSI standards.
- 7.4 Testing of Metering Equipment.** APS, on behalf of Transmission Owners, shall inspect and test all Transmission Owner Metering Equipment for the JPP upon installation and at least once every two (2) years thereafter. If requested to do so by Interconnection Customer, APS, on behalf of Transmission Owners, shall, at Interconnection Customer's expense, inspect or test such Metering Equipment more frequently than every two (2) years. APS, on behalf of Transmission Owners, shall give reasonable notice of the time when any inspection or test shall take place, and Interconnection Customer may have representatives present at the test or inspection. If at any time Metering Equipment is found to be inaccurate or defective, it shall be adjusted, repaired or replaced at Interconnection Customer's expense, in order to provide accurate metering, unless the inaccuracy or defect is due to Transmission Owners' failure to maintain, then Transmission Owners shall pay. If Metering Equipment fails to register, or if the measurement made by Metering Equipment during a test varies by more than two percent from the measurement made by the standard meter used in the test, APS, on behalf of Transmission Owners, shall adjust the measurements by correcting all measurements for the period during which Metering Equipment was in error by using Interconnection Customer's check meters, if installed. If no such check meters are installed or if the period cannot be reasonably ascertained, the adjustment shall be for the period immediately preceding the test of the Metering Equipment equal to one-half the time from the date of the last previous test of the Metering Equipment.
- 7.5 Metering Data.** At Interconnection Customer's expense, the metered data shall be telemetered to one or more locations designated by Transmission Owners and one or more locations designated by Interconnection Customer. Subject to Article 7.6, such telemetered data shall be used, under normal operating conditions, as the official measurement of the amount of energy delivered from the Large Generating Facility to the Point of Interconnection.
- 7.6 Metering Requirements of CAISO.** Notwithstanding the other provisions of Article 7, if the Interconnection Customer elects the CAISO as the Balancing Authority for a Project Phase, the Interconnection Customer shall also comply with the metering requirements of the CAISO Tariff for such Phase, including installation of Metering Equipment in compliance with the requirements of the CAISO Tariff. For Phase A of the Generating Facility the Interconnection Customer has selected the CAISO as the Balancing Authority, so for Phase A of the Generating Facility, in addition to the requirements of this Article 7, the Interconnection Customer shall also comply with the

metering requirements of the CAISO Tariff. If the Interconnection Customer elects the CAISO as the Balancing Authority for Phase B of the Generating Facility pursuant to Article 9.2 of this Agreement, the Interconnection Customer shall also comply with the requirements of this Article 7 and the metering requirements of the CAISO Tariff for Phase B of the Generating Facility. Notwithstanding the provisions of Article 7.5, for any Project Phase in the CAISO Balancing Authority Area, data from the CAISO-compliant metering shall be used, under normal operating conditions, as the official measurement of the amount of energy delivered from the Large Generating Facility to the Point of Interconnection. Any Metering Equipment installed by APS on behalf of the Transmission Owners will serve as an alternative source for meter data for the CAISO in the event of failure of the CAISO-compliant metering to provide accurate meter data.

Article 8. Communications

- 8.1 Interconnection Customer Obligations.** Interconnection Customer shall maintain satisfactory operating communications with APS's Transmission System dispatcher or representative designated by APS, and with CAISO, to the extent CAISO is selected by Interconnection Customer as Balancing Authority for a Project Phase. Interconnection Customer shall provide standard voice line, dedicated voice line and facsimile communications at its Large Generating Facility control room or central dispatch facility through use of either the public telephone system, or a voice communications system that does not rely on the public telephone system. Interconnection Customer shall also provide the dedicated data circuit(s) necessary to provide Interconnection Customer data to APS, on behalf of Transmission Owners as set forth in Appendix D, Security Arrangements Details, and as applicable, to CAISO. The data circuit(s) shall extend from the Large Generating Facility to the location(s) specified by APS, on behalf of Transmission Owners, and the CAISO. Any required maintenance of such communications equipment shall be performed by Interconnection Customer. Operational communications shall be activated and maintained under, but not be limited to, the following events: system paralleling or separation, scheduled and unscheduled shutdowns, equipment clearances, and hourly and daily load data.
- 8.2 Remote Terminal Unit.** Prior to the Initial Synchronization Date of any Project Phase, a Remote Terminal Unit, or equivalent data collection and transfer equipment acceptable to the Parties, shall be installed by Interconnection Customer, or by APS, on behalf of Transmission Owners, at Interconnection Customer's expense, to gather accumulated and instantaneous data to be telemetered to the location(s) designated by APS, on behalf of Transmission Owners, through use of a dedicated point-to-point data circuit(s) as indicated in Article 8.1. The communication protocol for the data circuit(s) shall be specified by APS, on behalf of Transmission Owners. Instantaneous bi-directional analog real power and reactive power flow information must be telemetered directly to the location(s) specified by APS.

As among APS, on behalf of Transmission Owners, CAISO and Interconnection Customer, each such Party will promptly advise the other Parties if it detects or otherwise learns of any metering, telemetry or communications equipment errors or malfunctions that require the attention and/or correction by the other Parties. The Party owning such equipment shall correct such error or malfunction as soon as reasonably feasible.

- 8.3 No Annexation.** Any and all equipment placed on the premises of a Party shall be and remain the property of the Party providing such equipment regardless of the mode and manner of annexation or attachment to real property, unless otherwise mutually agreed by the Parties.
- 8.4 Communication Requirements of CAISO.** Notwithstanding the other provisions of Article 8, if the Interconnection Customer elects the CAISO as the Balancing Authority for a Project Phase, the Interconnection Customer shall also comply with the communications requirements of the CAISO Tariff. For Phase A of the Generating Facility the Interconnection Customer has selected the CAISO as the Balancing Authority, so for Phase A of the Generating Facility, in addition to the requirements of this Article 8, the Interconnection Customer shall also comply with the communications requirements of the CAISO Tariff. If the Interconnection Customer elects the CAISO as the Balancing Authority for Phase B of the Generating Facility pursuant to Article 9.2 of this Agreement, the Interconnection Customer shall also comply with the requirements of this Article 8 and the communications requirements of the CAISO Tariff for Phase B of the Generating Facility.

Article 9. Operations

- 9.1 General.** Each Party shall comply with Applicable Reliability Standards and the Applicable Reliability Council requirements. Each Party shall provide to the other Parties all information that may reasonably be required by the other Parties to comply with Applicable Laws and Regulations and Applicable Reliability Standards.
- 9.2 Balancing Authority Area Notification.** At least three months before Initial Synchronization Date of a Project Phase, Interconnection Customer shall notify APS and the CAISO in writing of the Balancing Authority Area in which that Project Phase will be located, if and as permitted by the relevant transmission tariffs, including the APS and CAISO Tariffs. All necessary arrangements, including but not limited to those set forth in Articles 7 and 8 of this Agreement, and remote Balancing Authority Area generator interchange agreements, if applicable, and the appropriate measures under such agreements, shall be executed and implemented prior to the placement a Project Phase in the designated Balancing Authority Area. Separate notifications will be required for each Project Phase, as specified in Appendix C.
- 9.3 Transmission Owner and CAISO Obligations.** The Transmission Owners and the CAISO shall cause their respective Transmission Systems and APS, on behalf of Transmission Owners, shall cause the Transmission Owners' Interconnection Facilities to be operated, maintained and controlled in a safe and reliable manner and in accordance with this Agreement. APS and the CAISO may provide operating instructions to Interconnection Customer consistent with this Agreement and APS's or the CAISO's operating protocols and procedures as they may change from time to time. APS and the CAISO will consider changes to their respective operating protocols and procedures proposed by Interconnection Customer.
- 9.4 Interconnection Customer Obligations.** Interconnection Customer shall at its own expense operate, maintain and control the Large Generating Facility and Interconnection Customer's Interconnection Facilities in a safe and reliable manner and in accordance with this Agreement. Interconnection Customer shall operate the Large Generating

Facility and Interconnection Customer's Interconnection Facilities in accordance with all applicable requirements of the Balancing Authority Area of which it is part, as such requirements are set forth in Appendix C, Interconnection Details, of this Agreement. Appendix C, Interconnection Details, will be modified to reflect changes to the requirements as they may change from time to time. A Party may request that the other Parties provide copies of the requirements set forth in Appendix C, Interconnection Details, of this Agreement.

9.5 Start-Up and Synchronization. Consistent with the Parties' mutually acceptable procedures, Interconnection Customer is responsible for the proper synchronization of the Large Generating Facility to the JPP.

9.6 Reactive Power.

9.6.1 Power Factor Design Criteria. Interconnection Customer shall design Phase A of the Large Generating Facility to maintain a composite power delivery at continuous rated power output at the Point of Interconnection at a power factor within the range of 0.95 leading to 0.95 lagging, which power factor range shall supersede any otherwise applicable power factor range set forth in the CAISO Tariff. The Interconnection Customer shall design Phase B of the Large Generating Facility to maintain a composite power delivery at continuous rated power output at the Point of Interconnection at a power factor within the range of 0.95 leading to 0.95 lagging or the Applicable Reliability Standard in effect at the time the Interconnection Studies for Phase B of the Generating Facility are performed. For Phase B of the Generating Facility, the Interconnection Studies for that Project Phase demonstrate or shall demonstrate that that Project Phase complies with Article 9.6.1 before Phase B of the Interconnection Project commences Trial Operation.

9.6.2 Voltage Schedules. APS shall be responsible for compliance with Applicable Reliability Standards related to reactive power and voltage schedules for the interconnection of the Large Generating Facility to the JPP, subject to any agreement entered into by APS and the CAISO regarding the allocation of responsibilities for compliance with Applicable Reliability Standards. Pursuant to that responsibility, once Interconnection Customer has synchronized the Large Generating Facility with the JPP, APS shall require Interconnection Customer to operate the Large Generating Facility to produce or absorb reactive power within the design limitations of the Large Generating Facility set forth in Article 9.6.1 (Power Factor Design Criteria), Appendix C, and the Interconnection Customer's data, as revised, that were provided for the Interconnection Studies. Voltage schedules required by APS shall treat all sources of reactive power interconnected to the JPP in an equitable and not unduly discriminatory manner. APS shall exercise Reasonable Efforts to provide Interconnection Customer with such schedules at least one (1) day in advance, and may make changes to such schedules as necessary to maintain the reliability of the Transmission Systems. Interconnection Customer shall operate the Large Generating Facility to maintain the specified output voltage or power factor at the Point of Interconnection within the design limitations of the Large Generating Facility set forth in Article 9.6.1 (Power Factor Design Criteria), and the Interconnection Customer's data, as revised, that were provided for the Interconnection Studies. If Interconnection

Customer is unable to maintain the specified voltage or power factor, it shall promptly notify the APS system operator.

9.6.2.1 Governors and Regulators. To the extent required by Applicable Reliability Standards, the Interconnection Customer shall procure, install, and maintain governors and regulators. To the extent required by Applicable Reliability Standards, whenever the Large Generating Facility is operated in parallel with the Transmission System and the speed governors (if installed on the generating unit pursuant to Good Utility Practice) and voltage regulators are capable of operation, Interconnection Customer shall operate the Large Generating Facility with its speed governors and voltage regulators in automatic operation. If the Large Generating Facility's speed governors and voltage regulators are not capable of such automatic operation, Interconnection Customer shall immediately notify APS and the CAISO and ensure that such Large Generating Facility operates as specified in Article 9.6.2 through manual operation and that its reactive power production or absorption (measured in MVARs) are within the design capability of the Large Generating Facility's generating unit(s) and steady state stability limits. The Interconnection Customer shall restore the speed governors and voltage regulators to automatic operation as soon as possible. If the Large Generating Facility's speed governors and voltage regulators are improperly tuned or malfunctioning, APS or the CAISO shall have the right to order the reduction in output or disconnection of the Large Generating Facility if the reliability of the Transmission System would be adversely affected. Interconnection Customer shall not cause its Large Generating Facility to disconnect automatically or instantaneously from the Transmission System or trip any generating unit comprising the Large Generating Facility for an under or over frequency condition unless the abnormal frequency condition persists for a time period beyond the limits set forth in ANSI/IEEE Standard C37.106, or such other standard as applied to other generators interconnecting to the JPP on a comparable basis.

9.6.3 Payment for Reactive Power. APS is required to pay Interconnection Customer for reactive power that Interconnection Customer provides or absorbs from the Large Generating Facility when APS requests Interconnection Customer to operate its Large Generating Facility outside the range specified in Article 9.6.1, provided that if APS pays its own or affiliated generators for reactive power service within the specified range, it must also pay Interconnection Customer. Payments shall be pursuant to Article 11.6 or such other agreement to which the Parties have otherwise agreed.

9.7 Outages and Interruptions.

9.7.1 Outages.

9.7.1.1 Outage Authority and Coordination. Each Party may in accordance with Good Utility Practice in coordination with the other Parties remove from service any of its respective Interconnection Facilities or Network

Upgrades that may impact the other Parties' facilities as necessary to perform maintenance or testing or to install or replace equipment, provided that the Interconnection Customer shall also coordinate outages of the Generating Facility with the CAISO pursuant to the provisions of the CAISO Tariff for each Project Phase that is within the CAISO Balancing Authority Area, and APS shall coordinate outages of the JPP and Transmission Owner Interconnection Facilities with the CAISO in accordance with agreed procedures. Absent an Emergency Condition, the Party scheduling a removal of such facility(ies) from service will use Reasonable Efforts to schedule such removal on a date and time mutually acceptable to the Parties. In all circumstances, any Party planning to remove such facility(ies) from service shall use Reasonable Efforts to minimize the effect on the other Party of such removal.

9.7.1.2 Outage Schedules. APS, IID and CAISO shall post scheduled outages of their respective transmission facilities in accordance with applicable Tariff requirements. Interconnection Customer shall submit its planned maintenance schedules for the Large Generating Facility to APS for a minimum of a rolling twenty-four month period and to the CAISO in accordance with the CAISO Tariff for any Project Phase in the CAISO Balancing Authority Area. Interconnection Customer shall update its planned maintenance schedules as necessary, including providing updates to the CAISO in accordance with the CAISO Tariff. APS, on behalf of Transmission Owners, and the CAISO, in accordance with the applicable provisions of the CAISO Tariff, may request Interconnection Customer to reschedule its maintenance as necessary to maintain the reliability of Transmission Owners' and the CAISO Transmission Systems; provided, however, adequacy of generation supply shall not be a criterion in determining Transmission System reliability, subject to Section 9 of the CAISO Tariff. APS shall compensate Interconnection Customer for any additional direct costs that Interconnection Customer incurs as a result of having to reschedule maintenance, including any additional overtime, breaking of maintenance contracts or other costs above and beyond the cost Interconnection Customer would have incurred absent APS's request to reschedule maintenance. The CAISO shall compensate Interconnection Customer for any additional direct costs that Interconnection Customer incurs as a result of having to reschedule maintenance in accordance with the CAISO Tariff. Interconnection Customer will not be eligible to receive compensation, if during the twelve (12) months prior to the date of the scheduled maintenance, Interconnection Customer had modified its schedule of maintenance activities.

9.7.1.3 Outage Restoration. If an outage on a Party's Interconnection Facilities or Network Upgrades adversely affects another Party's operations or facilities, the Party that owns or controls the facility that is out of service shall use Reasonable Efforts to promptly restore such facility(ies) to a normal operating condition consistent with the nature of the outage. The Party that owns or controls the facility that is out of service shall provide the other Parties, to the extent such information is known, information on

the nature of the Emergency Condition, if the outage is caused by an Emergency Condition, an estimated time of restoration, and any corrective actions required. Initial verbal notice shall be followed up as soon as practicable with written notice explaining the nature of the outage, if requested by a Party, which may be provided by e-mail or facsimile.

9.7.2 Interruption of Service. If required by Good Utility Practice to do so, APS, on behalf of the Transmission Owners, may require Interconnection Customer to interrupt or reduce deliveries of electricity if such delivery of electricity could adversely affect the ability of APS to perform such activities as are necessary to safely and reliably operate and maintain the Transmission System. If the Interconnection Customer elects the CAISO as the Balancing Authority for a Project Phase, the CAISO may also have authority to require Interconnection Customer to curtail or interrupt such generation in accordance with the procedures established for generators in the CAISO Balancing Authority Area, in which case the procedures established by the CAISO pursuant to the CAISO Tariff shall apply in lieu of the provisions of this Article 9.7.2. APS or the CAISO shall notify the other as soon as possible of any curtailment, interruption, or reduction of deliveries from the Large Generating Facility that it may require. The following provisions shall apply to any interruption or reduction by APS permitted under this Article 9.7.2:

- 9.7.2.1** The interruption or reduction shall continue only for so long as reasonably necessary under Good Utility Practice;
- 9.7.2.2** Any such interruption or reduction shall be made on an equitable, non-discriminatory basis with respect to all generating facilities directly connected to its Transmission System;
- 9.7.2.3** When the interruption or reduction must be made under circumstances which do not allow for advance notice, APS shall notify Interconnection Customer by telephone as soon as practicable of the reasons for the curtailment, interruption, or reduction, and, if known, its expected duration. Telephone notification shall be followed by written notification, if requested by the Interconnection Customer, as soon as practicable;
- 9.7.2.4** Except during the existence of an Emergency Condition, when the interruption or reduction can be scheduled without advance notice, APS shall notify Interconnection Customer in advance regarding the timing of such scheduling and further notify Interconnection Customer of the expected duration. APS shall coordinate with Interconnection Customer using Good Utility Practice to schedule the interruption or reduction during periods of least impact to Interconnection Customer, and APS, acting on behalf of the Transmission Owners;
- 9.7.2.5** The Parties shall cooperate and coordinate with each other to the extent necessary in order to restore the Large Generating Facility, Interconnection Facilities, and their Transmission Systems to their

normal operating state, consistent with system conditions and Good Utility Practice.

9.7.3 Under-Frequency and Over Frequency Conditions. The Transmission System is designed to automatically activate a load-shed program as required by Applicable Reliability Standards and the Applicable Reliability Council in the event of an under-frequency system disturbance. Interconnection Customer shall implement under-frequency and over-frequency protection set points for the Large Generating Facility as required by the Applicable Reliability Standards and Applicable Reliability Council to ensure “ride through” capability of the Transmission System. Large Generating Facility response to frequency deviations of pre-determined magnitudes, both under-frequency and over-frequency deviations, shall be studied and coordinated with APS and the CAISO in accordance with Good Utility Practice. The term “ride through” as used herein shall mean the ability of a Generating Facility to stay connected to and synchronized with the Transmission System during system disturbances within a range of under-frequency and over-frequency conditions, in accordance with Good Utility Practice.

9.7.4 System Protection and Other Control Requirements.

9.7.4.1 System Protection Facilities. Interconnection Customer shall, at its expense, install, operate and maintain System Protection Facilities as a part of the Large Generating Facility or Interconnection Customer’s Interconnection Facilities. Transmission Owners shall install at Interconnection Customer’s expense any System Protection Facilities that may be required on Transmission Owners’ Interconnection Facilities and their Transmission Systems as a result of the interconnection of the Large Generating Facility and Interconnection Customer’s Interconnection Facilities.

9.7.4.2 The Transmission Owners’ and Interconnection Customer’s protection facilities shall be designed and coordinated with other systems in accordance with Applicable Reliability Standards, Applicable Reliability Council criteria and Good Utility Practice.

9.7.4.3 The Transmission Owners and Interconnection Customer shall be responsible for protection of their respective facilities consistent with Good Utility Practice.

9.7.4.4 The Transmission Owners’ and Interconnection Customer’s protective relay design shall incorporate the necessary test switches to perform the tests required in Article 6. The required test switches will be placed such that they allow operation of lockout relays while preventing breaker failure schemes from operating and causing unnecessary breaker operations and/or the tripping of Interconnection Customer’s units.

9.7.4.5 The Transmission Owners and Interconnection Customer will cause to be tested, operated and maintained System Protection Facilities in accordance with Good Utility Practice.

9.7.4.6 Prior to the in-service date, and again prior to the Commercial Operation Date, the Transmission Owners and Interconnection Customer or their respective agents shall perform a complete calibration test and functional trip test of the System Protection Facilities. At intervals suggested by Good Utility Practice and following any apparent malfunction of the System Protection Facilities, the Transmission Owners and Interconnection Customer shall perform both calibration and functional trip tests of their respective System Protection Facilities. These tests do not require the tripping of any in-service generation unit. These tests do, however, require that all protective relays and lockout contacts be activated.

9.7.5 Requirements for Protection. In compliance with Good Utility Practice, Interconnection Customer shall provide, install, own, and maintain relays, circuit breakers and all other devices necessary to remove any fault contribution of the Large Generating Facility to any short circuit occurring on the Transmission System not otherwise isolated by Transmission Owners' respective equipment, such that the removal of the fault contribution shall be coordinated with the protective requirements of the Transmission System. Such protective equipment shall include, without limitation, a disconnecting device or switch with fault current-interrupting capability located between the Large Generating Facility and the JPP at a site selected upon mutual agreement (not to be unreasonably withheld, conditioned or delayed) of the Parties. Interconnection Customer shall be responsible for protection of the Large Generating Facility and Interconnection Customer's other equipment from such conditions as negative sequence currents, over- or under-frequency, sudden load rejection, over- or under-voltage, and generator loss-of-field. Interconnection Customer shall be solely responsible to disconnect the Large Generating Facility and Interconnection Customer's other equipment if conditions on the Transmission System could adversely affect the Large Generating Facility.

9.7.6 Power Quality. Neither Party's facilities shall cause excessive voltage flicker nor introduce excessive distortion to the sinusoidal voltage or current waves as defined by ANSI Standard C84.1-1989, in accordance with IEEE Standard 519, or any applicable superseding electric industry standard or Applicable Reliability Standard. In the event of a conflict among ANSI Standard C84.1-1989, any applicable superseding electric industry standard or Applicable Reliability Standard, the Applicable Reliability Standard shall control.

9.8 Switching and Tagging Rules. APS, on behalf of Transmission Owners, and the Interconnection Customer shall provide each other a copy of its switching and tagging rules that are applicable to the other's activities. Such switching and tagging rules shall be developed on a non-discriminatory basis. APS, on behalf of Transmission Owners, and Interconnection Customer shall comply with applicable switching and tagging rules, as amended from time to time, in obtaining clearances for work or for switching operations on equipment.

9.9 Use of Interconnection Facilities by Third Parties.

- 9.9.1 Purpose of Interconnection Facilities.** Except as may be required by Applicable Laws and Regulations, or as otherwise agreed to among the Parties, the Interconnection Facilities shall be constructed for the sole purpose of interconnecting the Large Generating Facility to the JPP and shall be used for no other purpose.
- 9.9.2 Third Party Users.** If required by Applicable Laws and Regulations or if the Parties mutually agree, such agreement not to be unreasonably withheld, to allow one or more third parties to use Transmission Owners' Interconnection Facilities, or any part thereof, Interconnection Customer will be entitled to compensation for the capital expenses it incurred in connection with the Interconnection Facilities based upon the pro rata use of the Interconnection Facilities by each Transmission Owner, third party user, and Interconnection Customer, in accordance with Applicable Laws and Regulations or upon some other mutually-agreed upon methodology. In addition, cost responsibility for ongoing costs, including operation and maintenance costs associated with the Interconnection Facilities, will be allocated between Interconnection Customer and any third party users based upon the pro rata use of the Interconnection Facilities by each Transmission Owner, third party user, and Interconnection Customer, in accordance with Applicable Laws and Regulations or upon some other mutually agreed upon methodology. If the issue of such compensation or allocation cannot be resolved through such negotiations, it shall be submitted to arbitration pursuant to Article 27 of this Agreement or, if a complaint is made against a FERC jurisdictional public utility that is a Party to this Agreement, to FERC for resolution with respect to that FERC jurisdictional public utility.
- 9.10 Disturbance Analysis Data Exchange.** The Parties will cooperate with one another in the analysis of disturbances to either the Large Generating Facility or the Transmission Systems by gathering and providing access to any information relating to any disturbance, including information from oscillography, protective relay targets, breaker operations and sequence of events records, and any disturbance information required by Good Utility Practice.

Article 10. Maintenance

- 10.1 Transmission Owner Obligations.** Transmission Owners shall maintain the Transmission Owners' Transmission Systems and Transmission Owners' Interconnection Facilities in a safe and reliable manner and in accordance with this Agreement.
- 10.2 Interconnection Customer Obligations.** Interconnection Customer shall maintain the Large Generating Facility and Interconnection Customer's Interconnection Facilities in a safe and reliable manner and in accordance with this Agreement.
- 10.3 Coordination.** APS, on behalf of Transmission Owners, Interconnection Customer and the CAISO shall confer regularly to coordinate the planning, scheduling and performance of preventive and corrective maintenance on the Large Generating Facility and the Interconnection Facilities, which maintenance coordination shall be consistent with Article 9.7.1.

- 10.4 Secondary Systems.** APS, on behalf of Transmission Owners, Interconnection Customer and the CAISO shall cooperate with each other in the inspection, maintenance, and testing of control or power circuits that operate below 600 volts, AC or DC, including, but not limited to, any hardware, control or protective devices, cables, conductors, electric raceways, secondary equipment panels, transducers, batteries, chargers, and voltage and current transformers that directly affect the operation of such Parties' facilities and equipment which may reasonably be expected to impact the other Parties. APS, on behalf of Transmission Owners, Interconnection Customer and the CAISO shall provide advance notice to each other before undertaking any work on such circuits, especially on electrical circuits involving circuit breaker trip and close contacts, current transformers, or potential transformers.
- 10.5 Operating and Maintenance Expenses.** Subject to the provisions herein addressing the use of facilities by others, and except for operations and maintenance expenses associated with modifications made for providing interconnection or transmission service to a third party and such third party pays for such expenses, Interconnection Customer shall be responsible for all reasonable expenses including overheads, associated with: (1) owning, operating, maintaining, repairing, and replacing Interconnection Customer's Interconnection Facilities; and (2) operation, maintenance, repair and replacement of Transmission Owners' Interconnection Facilities.

Article 11. Performance Obligation

- 11.1 Interconnection Customer Interconnection Facilities.** Interconnection Customer shall design, procure, construct, install, own and/or control Interconnection Customer Interconnection Facilities described in Appendices A-1 and A-2 at its sole expense.
- 11.2 Transmission Owners' Interconnection Facilities.** APS, on behalf of Transmission Owners, shall design, procure, construct, install, own and/or control the Transmission Owners' Interconnection Facilities described in Appendices A-1 and A-2 at the sole expense of the Interconnection Customer.
- 11.3 Network Upgrades and Distribution Upgrades.** APS, on behalf of Transmission Owners shall design, procure, construct, and install, and the Transmission Owners shall jointly own the JPP Network Upgrades and Distribution Upgrades described in Appendices A-1 and A-2. SDG&E shall design, procure, construct, install, and own the non-JPP Network Upgrades described in Appendix A-3. Unless Transmission Owners, individually or collectively, elect to fund the capital for the Network Upgrades, they shall be solely funded by Interconnection Customer. For Network Upgrades to SDG&E's Transmission System, including SDG&E's share of the JPP, the amount of Interconnection Customer's cost responsibility to SDG&E shall be determined pursuant to the methodology set forth in Section 12.3.1 and Appendix 2 of the CAISO's Large Generator Interconnection Procedures.
- 11.4 Transmission Credits.**
- 11.4.1 Repayment of Amounts Advanced to APS for Network Upgrades to APS's Share of the JPP.** Interconnection Customer shall be entitled to a cash repayment from APS, equal to the total amount paid by Interconnection Customer to Transmission Owners for the Network Upgrades to the JPP

identified in Appendices A-1 and A-2, and not refunded to Interconnection Customer pursuant to Article 5.17.8 or otherwise, times APS's percentage Ownership Interest in the JPP ("APS's pro rata amount"), plus any tax gross-up or other tax-related payments associated with APS's pro rata amount, to be paid to Interconnection Customer on a dollar-for-dollar basis for the non-usage sensitive portion of transmission charges, as payments are made under APS's Tariff applicable to transmission services on APS's Transmission System with respect to the Large Generating Facility. Such repayment shall include interest calculated in accordance with the methodology set forth in FERC's regulations at 18 C.F.R. § 35.19a(a)(2)(iii) from the date of any payment for JPP Network Upgrades through the date on which the Interconnection Customer receives a repayment of such payment pursuant to this subparagraph. Interconnection Customer may assign such repayment rights to any person.

Notwithstanding the foregoing, Interconnection Customer and APS may adopt an alternative payment schedule that is mutually agreeable so long as APS takes one of the following actions no later than five years from the Commercial Operation Date for a Project Phase: (1) returns to Interconnection Customer any of its pro rata amounts advanced for JPP Network Upgrades not previously repaid, or (2) declares in writing that APS will continue to provide payments to Interconnection Customer on a dollar-for-dollar basis for the non-usage sensitive portion of transmission charges, or develop an alternative schedule that is mutually agreeable and provides for the return of all its pro rata amounts advanced for Network Upgrades not previously repaid; however, full reimbursement by APS of its pro rata amount shall not extend beyond twenty (20) years from the Commercial Operation Date for a Project Phase, and further, if this Agreement terminates within five (5) years from the Commercial Operation Date for that Project Phase, APS's obligation to pay refunds to the Interconnection Customer shall cease as of the date of termination.

If the Large Generating Facility fails to achieve Commercial Operation for a Project Phase, but it or another Generating Facility is later constructed and makes use of the Network Upgrades to the JPP associated with that Project Phase, APS shall at that time reimburse Interconnection Customer for APS's pro rata amount advanced to it for the JPP Network Upgrades for the Project Phase. Before any such reimbursement can occur, the Interconnection Customer, or the entity that ultimately constructs the Generating Facility, if different, is responsible for identifying and demonstrating to APS the entity to which reimbursement must be made in order to implement the intent of this reimbursement obligation.

11.4.2 Repayment of Amounts Advanced to SDG&E for Network Upgrades to Its Share of the JPP and to Its Non-JPP Facilities.

Upon the Commercial Operation Date for a Project Phase, the Interconnection Customer shall be entitled to a repayment, equal to the total amount paid by Interconnection Customer to SDG&E for the Network Upgrades to the JPP identified in Appendices A-1 and A-2, and not refunded to Interconnection Customer pursuant to Article 5.17.8 or otherwise, times SDG&E's percentage Ownership Interest in the JPP ("SDG&E's pro rata amount"), plus any amount paid to SDG&E for the costs of Network Upgrades to non-JPP facilities owned

by SDG&E set forth in Appendix A-3 and not refunded to Interconnection Customer pursuant to Article 5.17.8 or otherwise (“SDG&E’s individual amount”), plus any tax gross-up or other tax-related payments associated with Network Upgrades and not refunded to the Interconnection Customer pursuant to Article 5.17.8 or otherwise, and shall be paid to the Interconnection Customer by SDG&E on a dollar-for-dollar basis either through (1) direct payments made on a levelized basis over the five-year period commencing on the Commercial Operation Date for a Project Phase; or (2) any alternative payment schedule that is mutually agreeable to the Interconnection Customer and SDG&E, provided that such amount is paid within five (5) years from the Commercial Operation Date for a Project Phase. *See also* Appendices A-1 and A-2. Notwithstanding the foregoing, if this Agreement terminates within five (5) years from the Commercial Operation Date for that Project Phase, SDG&E’s obligation to pay refunds to the Interconnection Customer shall cease as of the date of termination. Any repayment shall include interest calculated in accordance with the methodology set forth in FERC’s regulations at 18 C.F.R. §35.19a(a)(2)(iii) from the date of any payment for Network Upgrades through the date on which the Interconnection Customer receives a repayment of such payment. Interest shall continue to accrue on the repayment obligation so long as this Agreement is in effect. The Interconnection Customer may assign such repayment rights to any person.

If the Large Generating Facility fails to achieve Commercial Operation for a Project Phase, but it or another Generating Facility is later constructed and makes use of the Network Upgrades associated with that Project Phase, SDG&E shall at that time reimburse Interconnection Customer for SDG&E’s pro rata amount and the individual amount advanced to SDG&E for the Network Upgrades for the Project Phase. Before any such reimbursement can occur, the Interconnection Customer, or the entity that ultimately constructs the Generating Facility, if different, is responsible for identifying and demonstrating to SDG&E the appropriate entity to which reimbursement must be made in order to implement the intent of this reimbursement obligation.

11.4.3 Repayment of Amounts Advanced to IID for Network Upgrades to IID’s Share of the JPP. The Parties acknowledge that IID is not a jurisdictional public utility subject to FERC’s rate jurisdiction under Section 205 or 206 of the Federal Power Act. The responsibility to provide transmission rate credits, under FERC’s generation interconnection regulations, therefore does not extend to IID. *See* Order No. 2003-C, 111 FERC ¶ 61,401, at P 18 (2005)(citing Order No. 2003, 104 FERC ¶ 61,103, at P 843 (2003)). Notwithstanding its non-jurisdictional status, IID hereby agrees to provide transmission rate credits to Interconnection Customer (or any other qualified person to whom Interconnection Customer assigns its rights to such transmission rate credits) when Point-to-Point Transmission Service is taken on IID’s share of the JPP as follows: IID shall provide such rate credits in an amount equal to the total amount paid by Interconnection Customer to Transmission Owners for the Network Upgrades to the JPP identified in Appendices A-1 and A-2 and not refunded to Interconnection Customer pursuant to Article 5.17.8 or otherwise, times IID’s percentage Ownership Interest in the JPP (“IID’s pro rata amount”). Such rate credits shall be provided by IID on a dollar-for-dollar basis for the non-

usage sensitive portion of IID's transmission charges (i.e., the demand charge for reserved capacity), as payments are made by Interconnection Customer (or any other qualified person to whom Interconnection Customer assigns its rights to transmission rate credits) to IID under IID's Open Access Transmission Tariff, for a period no longer than twenty (20) years from the Commercial Operation Date for a Project Phase. Notwithstanding the foregoing, if this Agreement terminates within five (5) years from the Commercial Operation Date for that Project Phase, IID's obligation to pay refunds to the Interconnection Customer shall cease as of the date of termination. IID also hereby agrees that Interconnection Customer may assign its rights to such transmission rate credits to any person which qualifies as an Eligible Customer for Point-to-Point Transmission Service under IID's Open Access Transmission Tariff.

If the Large Generating Facility fails to achieve Commercial Operation for a Project Phase, but it or another Generating Facility is later constructed and makes use of the Network Upgrades to the JPP associated with that Project Phase, IID shall reimburse Interconnection Customer for IID's pro rata amount advanced to it for the JPP Network Upgrades for the Project Phase, provided that IID receives payment of those amounts from the entity making use of the JPP Network Upgrades. Before any such reimbursement can occur, the Interconnection Customer, or the entity that ultimately constructs the Generating Facility, if different, is responsible for identifying and demonstrating to IID the appropriate entity to which reimbursement must be made in order to implement the intent of this reimbursement obligation.

11.4.4 Special Provisions for Affected Systems. Interconnection Customer and any Affected System Operator shall enter into a separate agreement that provides for the repayment of amounts advanced to such Affected System Operator for Network Upgrades. The agreement shall specify the terms governing payments to be made by Interconnection Customer to the Affected System Operator as well as the repayment by the Affected System Operator.

The Parties acknowledge that an Affected System Study must be performed by IID to analyze system impacts and identify the Network Upgrades, if any, that are required to IID's Transmission System, including its non-JPP facilities, to accommodate Interconnection Requests received by the CAISO from interconnection customers in the CAISO's Transition Cluster, as defined in the CAISO's LGIP, including the Interconnection Customer that is a Party to this Agreement. IID and Interconnection Customer have executed or will execute an Affected System Study Agreement for Phase A of the Generating Facility, whereby IID will perform and Interconnection Customer will pay the costs of an Affected System Study. The total costs will be pro rated to the extent IID performs the Affected System Study in a cluster for multiple generators seeking to interconnect to the CAISO controlled grid, with Interconnection Customer allocated a proportionate share of the total costs. Subject to the terms of a mutually-acceptable Non-Disclosure Agreement between the CAISO and IID, the CAISO shall provide to IID its applicable base case Interconnection Study data to assist IID in performing the Affected System Study.

The Parties acknowledge that there may be a need for an Affected System Study for Phase B of the Generating Facility, as provided for in Appendix C to this Agreement.

If an Affected System Study shows that Network Upgrades are required to IID's Transmission System, other than IID's share of the JPP, Interconnection Customer and IID agree that they shall enter into an Affected System Construction and Operation Agreement and that failure of the Interconnection Customer or IID to enter into such an agreement in accordance with the terms of this Article shall be considered a breach of this Agreement. The Interconnection Customer and IID agree that pursuant to the Affected System Construction and Operation Agreement: (1) Interconnection Customer shall fund the costs of constructing Network Upgrades reasonably attributable to Interconnection Customer; (2) IID shall use Reasonable Efforts to construct any Network Upgrades to IID's non-JPP facilities needed to accommodate Interconnection Customer's Interconnection Request to the CAISO on a schedule consistent with the provisions regarding testing in Article 6.1 of this Agreement; and (3) to the extent that the Interconnection Customer provides funding for any IID Network Upgrades identified in the Affected System Study, IID shall provide rate credits for the amount of such funding, which has not otherwise been refunded, applied on a dollar-for-dollar basis to the non-usage sensitive portion of IID's transmission charges (i.e., the demand charge for reserved capacity), as payments are made by Interconnection Customer (or any other qualified person to whom Interconnection Customer assigns its rights to transmission rate credits) under IID's Tariff, for a period no longer than twenty (20) years from the Commercial Operation Date for the Project Phase.

Any disputes between Interconnection Customer and IID regarding the Affected System Study Agreement or Affected System Construction and Operation Agreement shall be resolved pursuant to the dispute resolution procedures in Section 13.5 of the Generation Interconnection Procedures in IID's Tariff.

11.4.5 Notwithstanding any other provision of this Agreement, nothing herein shall be construed as relinquishing or foreclosing any rights, including but not limited to firm transmission rights, capacity rights, transmission congestion rights, "Congestion Revenue Rights" defined in and available pursuant to the terms of the CAISO Tariff, or transmission credits, that Interconnection Customer, shall be entitled to, now or in the future, under any other agreement or tariff as a result of, or otherwise associated with, the transmission capacity, if any, created by the Network Upgrades, including the right to obtain cash reimbursements, merchant transmission "Congestion Revenue Rights" in accordance with Section 36.11 of the CAISO Tariff, or transmission credits for transmission service that is not associated with the Large Generating Facility.

11.5 Provision of Security. With regard to SDG&E's share of costs to be incurred for Transmission Owners' Interconnection Facilities and Network Upgrades to the JPP identified in Appendices A-1 and A-2, and for SDG&E's costs of Network Upgrades identified in Appendix A-3, the Interconnection Customer shall provide (or cause to be provided) all necessary Interconnection Financial Security required under Section 9 of the CAISO's LGIP in a manner acceptable under Section 9 of the CAISO's LGIP.

Failure to satisfy the CAISO's LGIP's requirements for the provision of Interconnection Financial Security shall result in the Interconnection Request being deemed withdrawn and subject to CAISO LGIP Section 3.8.

With regard to APS and IID's shares of the costs to be incurred for Interconnection Facilities and Network Upgrades to the JPP identified in Appendices A-1 and A-2, at least thirty (30) Calendar Days prior to the commencement of the procurement, installation, or construction of Transmission Owners' Interconnection Facilities and JPP Network Upgrades, the Interconnection Customer shall provide (or cause to be provided) APS, on behalf of APS and IID, a guarantee, a surety bond, letter of credit or other form of security that is reasonably acceptable to APS and IID, and is consistent with the Uniform Commercial Code of the jurisdiction identified in Article 14.2.1. Such security for payment shall be in an amount sufficient to cover the costs for constructing, procuring and installing both APS and IID's shares of the Transmission Owners' Interconnection Facilities and JPP Network Upgrades set forth in Appendices A-1 and A-2, and shall be reduced on a dollar-for-dollar basis for payments made to APS, on behalf of APS and IID, for these purposes.

The Parties agree that APS, as the Operating Agent of the JPP under the Participation Agreement, and solely as agent for APS and IID, will accept delivery of the financial security required for the APS and IID shares of the Transmission Owners' Interconnection Facilities and Network Upgrades to the JPP set forth in Appendices A-1 and A-2, which the Interconnection Customer is required to provide (or cause to be provided) in accordance with the milestone schedule set forth in Appendices B-1 and B-2. APS's receipt of any such financial security will be solely as agent for APS and IID, and APS shall have no obligations to the Interconnection Customer with regard to such financial security other than any obligation it may have for the APS and IID shares of such financial security; APS shall have all obligations, if any, to the Interconnection Customer for the APS and IID shares of such financial security. If it becomes necessary for the Transmission Owners to enforce their financial security rights, APS shall do so, as Operating Agent of the JPP, on behalf of APS and IID in accordance with the procedures set forth in Appendices A-1 and A-2.

SDG&E shall hold the Interconnection Financial Security required for SDG&E's Ownership Share in accordance with the requirements of the CAISO Tariff, provided, however, that if it becomes necessary for the Transmission Owners to enforce their financial security rights, SDG&E shall do so in accordance with the CAISO Tariff and the procedures set forth in Appendices A-1 and A-2.

In addition to complying with all requirements of the CAISO's Large Generator Interconnection Procedures regarding Interconnection Financial Security for security provided to SDG&E:

11.5.1 Any guarantee provided to APS, on behalf of APS and IID, and/or SDG&E, as applicable, must be made by an entity that meets the creditworthiness requirements of APS and IID and/or SDG&E, as applicable, and contain terms and conditions that guarantee payment of any amount that may be due from Interconnection Customer, up to an agreed-to maximum amount.

11.5.2 Any letter of credit to APS, on behalf of APS and IID, and/or SDG&E, , as applicable, must be issued by a financial institution reasonably acceptable to APS and IID and/or SDG&E, as applicable, and must specify a reasonable expiration date.

11.5.3 Any surety bond to APS, on behalf of APS and IID, and/or SDG&E, as applicable, must be issued by an insurer reasonably acceptable to APS and IID and/or SDG&E, as applicable, and must specify a reasonable expiration date.

Security shall be provided separately for Phase A of the Interconnection Project and Phase B of the Interconnection Project. Failure of the Interconnection Customer to have any required financial security in place at any time shall constitute grounds for termination of this Agreement pursuant to Articles 2.3 and 17.1, provided, however, Interconnection Customer shall have only 5 (five) Business Days to cure such failure following notice of the default. In addition to the foregoing, the obligation of Transmission Owners to perform under this Agreement is suspended until such failure is cured.

11.6 Interconnection Customer Compensation. If a Transmission Owner or the CAISO requests or directs Interconnection Customer to provide a service pursuant to 13.5.1 of this Agreement, the Transmission Owner or the CAISO requesting service shall compensate Interconnection Customer in accordance with its Tariff.

11.6.1 Interconnection Customer Compensation for Actions During Emergency Condition. The Transmission Owner or the CAISO requesting the Interconnection Customer to provide service during an Emergency Condition shall compensate Interconnection Customer for its provision of real and reactive power and other Emergency Condition services that Interconnection Customer provides to support its Transmission System during an Emergency Condition in accordance with Article 11.6.

Article 12. Invoice

12.1 General Provisions. For purposes of this Article, as between APS, on behalf of Transmission Owners of the JPP, and Interconnection Customer, each such Party shall submit to the other Party, on a monthly basis, invoices of amounts due for the preceding month with respect to JPP facilities. As between SDG&E, as owner of certain non-JPP facilities under this Agreement, and Interconnection Customer, each such Party shall submit to the other Party, on a monthly basis, invoices of amounts due for the preceding month for such non-JPP facilities owned solely by SDG&E.

Each invoice shall state the month to which the invoice applies and fully describe the services and equipment provided. The Parties may discharge mutual debts and payment obligations due and owing to each other on the same date through netting, in which case all amounts a Party owes to the other Party under this Agreement, including interest payments or credits, shall be netted so that only the net amount remaining due shall be paid by the owing Party; provided, however, that the Parties shall not net amounts relating to JPP facilities with those related to non-JPP facilities. Notwithstanding the foregoing, any invoices between the CAISO and another Party pursuant to the CAISO Tariff shall be submitted and paid in accordance with the CAISO Tariff.

Invoices shall be provided separately for Phase A of the Interconnection Project and Phase B of the Interconnection Project.

- 12.2 Final Invoice.** Within six months after completion of the construction of Transmission Owners' Interconnection Facilities and the Network Upgrades to the JPP for Phase A of the Interconnection Project and Phase B of the Interconnection Project, APS, on behalf of Transmission Owners, with respect to the Transmission Owners' Interconnection Facilities and JPP Network Upgrades identified in Appendices A-1 and A-2 and SDG&E with respect to its non-JPP Network Upgrades identified in Appendix A-3, shall each provide an invoice of the final cost of the construction of their respective Transmission Owners' Interconnection Facilities and the Network Upgrades and shall set forth such costs in sufficient detail to enable Interconnection Customer to compare the actual costs with the estimates and to ascertain deviations, if any, from the cost estimates.

With respect to costs associated with the Transmission Owners' Interconnection Facilities and the JPP Network Upgrades, APS, on behalf of Transmission Owners, shall refund to Interconnection Customer any amount by which the actual payment by Interconnection Customer for the estimated costs of such facilities exceeds the actual costs of construction within thirty (30) Calendar Days of the issuance of such final construction invoice; or, in the event the actual costs of construction exceed the Interconnection Customer's actual payment for estimated costs, then the Interconnection Customer shall pay to APS, on behalf of the Transmission Owners, any amount by which the actual costs of construction exceed the actual payment by the Interconnection Customer for the estimated costs within thirty (30) Calendar Days of the issuance of such final construction invoice.

With respect to costs associated with SDG&E's non-JPP Network Upgrades identified in Appendix A-3, SDG&E shall be responsible for refunding to the Interconnection Customer any amount by which the actual payment by the Interconnection Customer for estimated costs of such facilities exceeds the actual costs of construction, within thirty (30) Calendar Days of the issuance of such final construction invoice. In the event the actual costs of construction multiplied by the Interconnection Customer's percentage share of those costs exceed the Interconnection Customer's actual payment for estimated costs, then SDG&E shall be responsible for recovering such difference through its transmission service rates.

Invoices shall be provided separately for Phase A of the Interconnection Project and Phase B of the Interconnection Project.

- 12.3 Payment.** Invoices shall be rendered to the paying Party at the address specified in Appendix F. The Party receiving the invoice shall pay the invoice within thirty (30) Calendar Days of receipt. All payments shall be made in immediately available funds payable to the other Party, or by wire transfer to a bank named and account designated by the invoicing Party. Payment of invoices by either Party will not constitute a waiver of any rights or claims either Party may have under this Agreement.

- 12.4 Disputes.** In the event of a billing dispute between Transmission Owners and Interconnection Customer, Transmission Owners and the CAISO shall continue to provide Interconnection Service under this Agreement as long as Interconnection

Customer: (i) continues to make all payments not in dispute; and (ii) pays to Transmission Owners or into an independent escrow account the portion of the invoice in dispute, pending resolution of such dispute. If Interconnection Customer fails to meet these two requirements for continuation of service, then Transmission Owners may provide notice to Interconnection Customer of a Default pursuant to Article 17. Within thirty (30) Calendar Days after the resolution of the dispute, the Party that owes money to the other Party shall pay the amount due with interest calculated in accord with the methodology set forth in FERC's regulations at 18 CFR § 35.19a(a)(2)(iii). Notwithstanding the foregoing, any billing dispute between the CAISO, Interconnection Customer and/or SDG&E shall be resolved in accordance with the provisions of Article 27 of this Agreement.

Article 13. Emergencies

- 13.1 Definition.** "Emergency Condition" shall have the meaning set forth in Article 1.
- 13.2 Obligations.** Interconnection Customer, SDG&E and the CAISO shall comply with the Emergency Condition procedures of the CAISO, and all Parties shall comply with the Emergency Condition procedures of NERC, the Applicable Reliability Council, Applicable Reliability Standards, Applicable Laws and Regulations, and any emergency procedures set forth in this Agreement or agreed to by the Joint Operating Committee that are consistent with the other Emergency Condition procedures with which compliance is required by this Article 13.2.
- 13.3 Notice.** With respect to any facility which a Transmission Owner or the CAISO controls, the Transmission Owner or the CAISO shall notify Interconnection Customer promptly when it becomes aware of an Emergency Condition that affects Transmission Owners' Interconnection Facilities or such Transmission Owner's or the CAISO's Transmission System that may reasonably be expected to affect Interconnection Customer's operation of the Large Generating Facility or Interconnection Customer's Interconnection Facilities. Interconnection Customer shall notify Transmission Owners and the CAISO promptly when it becomes aware of an Emergency Condition that affects the Large Generating Facility or Interconnection Customer's Interconnection Facilities that may reasonably be expected to affect the Transmission Systems or Transmission Owners' Interconnection Facilities. To the extent information is known, the notification shall describe the Emergency Condition, the extent of the damage or deficiency, the expected effect on the operation of Interconnection Customer's or such Transmission Owner's or the CAISO's facilities and operations, its anticipated duration and the corrective action taken and/or to be taken. The initial notice shall be followed as soon as practicable with written notice, if requested by a Party, which may be provided by electronic mail or facsimile, or in the case of the CAISO may be publicly posted on the CAISO's internet website.
- 13.4 Immediate Action.** Unless, in Interconnection Customer's reasonable judgment, immediate action is required, Interconnection Customer shall obtain the consent of APS and the CAISO, such consent to not be unreasonably withheld, prior to performing any manual switching operations at the Large Generating Facility or Interconnection Customer's Interconnection Facilities in response to an Emergency Condition either declared by APS, on behalf of the Transmission Owners, or the CAISO or otherwise regarding the Transmission Systems.

13.5 Transmission Owner and CAISO Authority.

13.5.1 General. Transmission Owners and the CAISO may take whatever actions or inactions with regard to their affected Transmission Systems or Transmission Owners' Interconnection Facilities they deem necessary during an Emergency Condition in order to (i) preserve public health and safety, (ii) preserve the reliability of the affected Transmission Systems or Transmission Owners' Interconnection Facilities, (iii) limit or prevent damage, and (iv) expedite restoration of service.

Transmission Owners and the CAISO shall use Reasonable Efforts to minimize the effect of such actions or inactions on the Large Generating Facility or Interconnection Customer's Interconnection Facilities. APS, on behalf of Transmission Owners, and the CAISO may, on the basis of technical considerations, require the Large Generating Facility to mitigate an Emergency Condition by taking actions necessary and limited in scope to remedy the Emergency Condition, including, but not limited to, directing Interconnection Customer to shut-down, start-up, increase or decrease the real or reactive power output of the Large Generating Facility; implementing a reduction or disconnection pursuant to Article 13.5.2; directing Interconnection Customer to assist with blackstart (if available) or restoration efforts; or altering the outage schedules of the Large Generating Facility and Interconnection Customer's Interconnection Facilities. Subject to the provisions of Articles 9.6.1 and 9.6.2, Interconnection Customer shall comply with all of APS's operating instructions concerning Large Generating Facility real power and reactive power output within the manufacturer's design limitations of the Large Generating Facility's equipment that is in service and physically available for operation at the time, in compliance with Applicable Laws and Regulations and Applicable Reliability Standards.

13.5.2 Reduction and Disconnection. APS, on behalf of Transmission Owners, or the CAISO may reduce Interconnection Service, and APS may disconnect the Large Generating Facility or Interconnection Customer's Interconnection Facilities, when such reduction or disconnection is necessary under Good Utility Practice due to Emergency Conditions. These rights are separate and distinct from any right of curtailment of Transmission Owners or the CAISO pursuant to their respective Tariffs. When APS, on behalf of Transmission Owners, or the CAISO can schedule the reduction or disconnection in advance, APS or the CAISO shall notify Interconnection Customer of the reasons, timing and expected duration of the reduction or disconnection and shall coordinate with the other in accordance with Articles 9.7.1 and 9.7.2. APS and the CAISO shall coordinate with Interconnection Customer using Good Utility Practice to schedule the reduction or disconnection during periods of least impact to Interconnection Customer and Transmission Owners and the CAISO. Any reduction or disconnection shall continue only for so long as reasonably necessary under Good Utility Practice. The Parties shall cooperate with each other to restore the Large Generating Facility, the Interconnection Facilities, and the Transmission System to their normal operating state as soon as practicable consistent with Good Utility Practice.

- 13.6 Interconnection Customer Authority.** Consistent with Good Utility Practice, this Agreement and applicable Tariffs, Interconnection Customer may take actions or inactions with regard to the Large Generating Facility or Interconnection Customer's Interconnection Facilities during an Emergency Condition in order to (i) preserve public health and safety, (ii) preserve the reliability of the Large Generating Facility or Interconnection Customer's Interconnection Facilities, (iii) limit or prevent damage, and (iv) expedite restoration of service. Interconnection Customer shall use Reasonable Efforts to minimize the effect of such actions or inactions on the affected Transmission System(s) and Transmission Owners' Interconnection Facilities. Each affected Transmission Owner and the CAISO shall use Reasonable Efforts to assist Interconnection Customer in such actions.
- 13.7 Limited Liability.** Except as otherwise provided in Article 11.6.1 of this Agreement, no Party shall be liable to the others for any action it takes in responding to an Emergency Condition so long as such action is made in good faith and is consistent with Good Utility Practice.

Article 14. Regulatory Requirements and Governing Law

- 14.1 Regulatory Requirements.** A Party's obligations under this Agreement shall be subject to its receipt of any required approval or certificate from one or more Governmental Authorities in the form and substance satisfactory to the applying Party, or the Party making any required filings with, or providing notice to, such Governmental Authorities, and the expiration of any time period associated therewith. A Party shall in good faith seek and use its Reasonable Efforts to obtain such other approvals. Nothing in this Agreement shall require Interconnection Customer or other Party to take any action that could result in its inability to obtain, or its loss of, status or exemption under the Federal Power Act, the Public Utility Holding Company Act of 1935, as amended, or the Public Utility Regulatory Policies Act of 1978.
- 14.2 Governing Law.**
- 14.2.1** The validity, interpretation and performance of this Agreement and each of its provisions shall be governed by the laws of the state where the Point of Interconnection is located, without regard to its conflicts of law principles.
- 14.2.2** This Agreement is subject to all Applicable Laws and Regulations.
- 14.2.3** Each Party expressly reserves the right to seek changes in, appeal, or otherwise contest any laws, orders, rules, or regulations of a Governmental Authority.

Article 15. Notices.

- 15.1 General.** Unless otherwise provided in this Agreement, any notice, demand or request required or permitted to be given by a Party to the others and any instrument required or permitted to be tendered or delivered by a Party in writing to the others shall be effective when delivered and may be so given, tendered or delivered, by recognized national courier, or by depositing the same with the United States Postal Service with postage prepaid, for delivery by certified or registered mail, addressed to the Parties, or personally

delivered to the Parties, at the address set out in Appendix F, Addresses for Delivery of Notices and Billings.

A Party must update the information in Appendix F as information changes. A Party may change the notice information in this Agreement by giving five (5) Business Days written notice prior to the effective date of the change. Such changes shall not constitute an amendment to this Agreement.

- 15.2 Billings and Payments.** Billings and payments shall be sent to the addresses set out in Appendix F.
- 15.3 Alternative Forms of Notice.** Any notice or request required or permitted to be given by a Party to the other and not required by this Agreement to be given in writing may be so given by telephone, facsimile or email to the telephone numbers and email addresses set out in Appendix F.
- 15.4 Operations and Maintenance Notice.** APS and the CAISO shall notify the other Parties in writing of the identity of the person(s) that they designate as the point(s) of contact with respect to the implementation of Articles 9 and 10.

Article 16. Force Majeure

16.1 Force Majeure.

16.1.1 Economic hardship is not considered a Force Majeure event.

16.1.2 No Party shall be considered to be in Default with respect to any obligation hereunder, (including obligations under Article 4), other than the obligation to pay money when due, if prevented from fulfilling such obligation by Force Majeure. A Party unable to fulfill any obligation hereunder (other than an obligation to pay money when due) by reason of Force Majeure shall give notice and the full particulars of such Force Majeure to the other Parties in writing or by telephone as soon as reasonably possible after the occurrence of the cause relied upon. Telephone notices given pursuant to this article shall be confirmed in writing as soon as reasonably possible and shall specifically state full particulars of the Force Majeure, the time and date when the Force Majeure occurred and when the Force Majeure is reasonably expected to cease. The Party affected shall exercise due diligence to remove such disability with reasonable dispatch, but shall not be required to accede or agree to any provision not satisfactory to it in order to settle and terminate a strike or other labor disturbance.

Article 17. Default

17.1 Default

17.1.1 General. No Default shall exist where such failure to discharge an obligation (other than the payment of money or posting of security) is the result of Force Majeure as defined in this Agreement or the result of an act of omission of the other Parties. Upon a Breach, the affected non-Breaching Parties shall give written notice of such Breach to the Breaching Party. Except as provided in

Article 17.1.2, the Breaching Party shall have thirty (30) Calendar Days from receipt of the Default notice within which to cure such Breach; provided however, if such Breach is not capable of cure within thirty (30) Calendar Days, the Breaching Party shall commence such cure within thirty (30) Calendar Days after notice and continuously and diligently complete such cure within ninety (90) Calendar Days from receipt of the Default notice; and, if cured within such time, the Breach specified in such notice shall cease to exist. If one but not both of the entities comprising the Interconnection Customer breaches this Agreement, the non-Breaching Party shall accept performance from the Interconnection Customer entity to the extent it continues to perform under this Agreement.

17.1.2 Right to Terminate. If a Breach is not cured as provided in this article or as provided in Article 11.5.3 with respect to the posting of financial security, or if a Breach is not capable of being cured within the period provided for herein, an affected non-Breaching Party shall have the right to declare a Default and terminate this Agreement by written notice at any time until cure occurs, and be relieved of any further obligation hereunder and, whether or not that Party terminates this Agreement, to recover from the Breaching Party all amounts due hereunder, plus all other damages and remedies to which it is entitled at law or in equity. The provisions of this article will survive termination of this Agreement.

Article 18. Indemnity, Consequential Damages and Insurance

18.1 Indemnity. A Party shall at all times indemnify, defend, and hold another Party, harmless from, any and all Losses arising out of or resulting from that particular Party's actions or inactions of its obligations under this Agreement on behalf of the indemnifying Party, except in cases of gross negligence or intentional wrongdoing by the indemnified Party.

18.1.1 Indemnified Party. If an indemnified Party is entitled to indemnification under this Article 18 as a result of a claim by a third party, and the indemnifying Party fails, after notice and reasonable opportunity to proceed under Article 18.1, to assume the defense of such claim, such indemnified Party may at the expense of the indemnifying Party contest, settle or consent to the entry of any judgment with respect to, or pay in full, such claim.

18.1.2 Indemnifying Party. If an indemnifying Party is obligated to indemnify and hold any indemnified Party harmless under this Article 18, the amount owing to the indemnified Party shall be the amount of such indemnified Party's actual Loss, net of any insurance or other recovery.

18.1.3 Indemnity Procedures. Promptly after receipt by an indemnified Party of any claim or notice of the commencement of any action or administrative or legal proceeding or investigation as to which the indemnity provided for in Article 18.1 may apply, the indemnified Party shall notify the indemnifying Party of such fact. Any failure of or delay in such notification shall not affect a Party's indemnification obligation unless such failure or delay is materially prejudicial to the indemnifying Party.

The indemnifying Party shall have the right to assume the defense thereof with counsel designated by such indemnifying Party and reasonably satisfactory to the indemnified Party. If the defendants in any such action include one or more indemnified Parties and the indemnifying Party and if the indemnified Party reasonably concludes that there may be legal defenses available to it and/or other indemnified Parties which are different from or additional to those available to the indemnifying Party, the indemnified Party shall have the right to select separate counsel to assert such legal defenses and to otherwise participate in the defense of such action on its own behalf. In such instances, the indemnifying Party shall only be required to pay the fees and expenses of one additional attorney to represent an indemnified Party or indemnified Parties having such differing or additional legal defenses.

The indemnified Party shall be entitled, at its expense, to participate in any such action, suit or proceeding, the defense of which has been assumed by the indemnifying Party. Notwithstanding the foregoing, the indemnifying Party (i) shall not be entitled to assume and control the defense of any such action, suit or proceedings if and to the extent that, in the opinion of the indemnified Party and its counsel, such action, suit or proceeding involves the potential imposition of criminal liability on the indemnified Party, or there exists a conflict or adversity of interest between the indemnified Party and the indemnifying Party, in such event the indemnifying Party shall pay the reasonable expenses of the indemnified Party, and (ii) shall not settle or consent to the entry of any judgment in any action, suit or proceeding without the consent of the indemnified Party, which shall not be reasonably withheld, conditioned or delayed.

18.2 Consequential Damages. In no event shall a Party be liable under any provision of this Agreement for any losses, damages, costs or expenses for any special, indirect, incidental, consequential, or punitive damages, including but not limited to loss of profit or revenue, loss of the use of equipment, cost of capital, cost of temporary equipment or services, whether based in whole or in part in contract, in tort, including negligence, strict liability, or any other theory of liability; provided, however, that damages for which a Party may be liable to another Party under another agreement will not be considered to be special, indirect, incidental, or consequential damages hereunder.

18.3 Insurance. A Party shall, at its own expense, maintain in force throughout the period of this Agreement, and until released by the other Party(ies), the following minimum insurance coverages, with insurers authorized to do business in the state where the Point of Interconnection is located:

18.3.1 Employer's Liability and Workers' Compensation Insurance providing statutory benefits in accordance with the laws and regulations of the state in which the Point of Interconnection is located, except in the case of the CAISO, the State of California.

18.3.2 Commercial General Liability Insurance including premises and operations, personal injury, broad form property damage, broad form blanket contractual liability coverage (including coverage for the contractual indemnification) products and completed operations coverage, coverage for explosion, collapse and underground hazards, independent contractors coverage, coverage for

pollution to the extent normally available and punitive damages to the extent normally available and a cross liability endorsement, with minimum limits of One Million Dollars (\$1,000,000) per occurrence/One Million Dollars (\$1,000,000) aggregate combined single limit for personal injury, bodily injury, including death and property damage.

- 18.3.3** Business Automobile Liability Insurance for coverage of owned and non-owned and hired vehicles, trailers or semi-trailers designed for travel on public roads, with a minimum, combined single limit of One Million Dollars (\$1,000,000) per occurrence for bodily injury, including death, and property damage.
- 18.3.4** Excess Public Liability Insurance over and above the Employer's Liability Commercial General Liability and Business Automobile Liability Insurance coverage, with a minimum combined single limit of Twenty Million Dollars (\$20,000,000) per occurrence/Twenty Million Dollars (\$20,000,000) aggregate.
- 18.3.5** The Commercial General Liability Insurance, Business Automobile Insurance and Excess Public Liability Insurance policies shall name the other Party, their parents, associated and Affiliate companies and their respective directors, officers, agents, servants and employees ("Other Party Group") as additional insured. All policies shall contain provisions whereby the insurers waive all rights of subrogation in accordance with the provisions of this Agreement against the Other Party Group and provide thirty (30) Calendar Days advance written notice to the Other Party Group prior to anniversary date of cancellation or any material change in coverage or condition.
- 18.3.6** The Commercial General Liability Insurance, Business Automobile Liability Insurance and Excess Public Liability Insurance policies shall contain provisions that specify that the policies are primary and shall apply to such extent without consideration for other policies separately carried and shall state that each insured is provided coverage as though a separate policy had been issued to each, except the insurer's liability shall not be increased beyond the amount for which the insurer would have been liable had only one insured been covered. Each Party shall be responsible for its respective deductibles or retentions.
- 18.3.7** The Commercial General Liability Insurance, Business Automobile Liability Insurance and Excess Public Liability Insurance policies, if written on a Claims First Made Basis, shall be maintained in full force and effect for two (2) years after termination of this Agreement, which coverage may be in the form of tail coverage or extended reporting period coverage if agreed by the Parties.
- 18.3.8** The requirements contained herein as to the types and limits of all insurance to be maintained by the Parties are not intended to and shall not in any manner, limit or qualify the liabilities and obligations assumed by the Parties under this Agreement.
- 18.3.9** Within ten (10) Calendar Days following execution of this Agreement, and as soon as practicable after the end of each fiscal year or at the renewal of the insurance policy and in any event within ninety (90) Calendar Days thereafter,

each Party shall provide certification of all insurance required in this Agreement, executed by each insurer or by an authorized representative of each insurer.

18.3.10 Notwithstanding the foregoing, each Party may self-insure to meet the minimum insurance requirements of Articles 18.3.2 through 18.3.8 to the extent it maintains a self-insurance program; provided that, such Party's senior unsecured debt or issuer rating is BBB-, or better as rated by Standard & Poor's and that its self-insurance program meets the minimum insurance requirements of Articles 18.3.2 through 18.3.8. For any period of time that a Party's senior unsecured debt rating and issuer rating are both rated at less than BBB- by Standard & Poor's, such Party shall comply with the insurance requirements applicable to it under Articles 18.3.2 through 18.3.9. In the event that a Party is permitted to self-insure pursuant to this article, it shall notify the other Parties that it meets the requirements to self-insure and that its self-insurance program meets the minimum insurance requirements in a manner consistent with that specified in Article 18.3.9.

18.3.11 The Parties agree to report to each other in writing as soon as practical all accidents or occurrences resulting in injuries to any person, including death, and any property damage arising out of this Agreement.

Article 19. Assignment

19.1 Assignment. This Agreement may be assigned by a Party only with the written consent of the other Parties; provided that a Party may assign this Agreement without the consent of the other Parties to any Affiliate of the assigning Party with an equal or greater credit rating and with the legal authority and operational ability to satisfy the obligations of the assigning Party under this Agreement; and provided further that Interconnection Customer shall have the right to assign this Agreement, without the consent of the other Parties, for collateral security purposes to aid in providing financing for the Large Generating Facility or a Project Phase of the Large Generating Facility, provided that Interconnection Customer will promptly notify the Parties of any such assignment. Any financing arrangement entered into by Interconnection Customer pursuant to this article will provide that prior to or upon the exercise of the secured party's, trustee's or mortgagee's assignment rights pursuant to said arrangement, the secured creditor, the trustee or mortgagee will notify the Parties of the date and particulars of any such exercise of assignment right(s), including providing the Parties with proof that it meets the requirements of Articles 11.5 and 18.3. Any attempted assignment that violates this article is void and ineffective. Any assignment under this Agreement shall not relieve a Party of its obligations, nor shall a Party's obligations be enlarged, in whole or in part, by reason thereof. Where required, consent to assignment will not be unreasonably withheld, conditioned or delayed.

Article 20. Severability

20.1 Severability. If any provision in this Agreement is finally determined to be invalid, void or unenforceable by any court or other Governmental Authority having jurisdiction, such determination shall not invalidate, void or make unenforceable any other provision, agreement or covenant of this Agreement; provided that if Interconnection Customer (or any third party, but only if such third party is not acting at the direction of a Transmission

Owner or the CAISO) seeks and obtains such a final determination with respect to any provision of the Alternate Option (Article 5.1.2), or the Negotiated Option (Article 5.1.4), then none of these provisions shall thereafter have any force or effect and the Parties' rights and obligations shall be governed solely by the Standard Option (Article 5.1.1).

Article 21. Comparability

21.1 Comparability. The Parties which are FERC-jurisdictional public utilities will comply with all applicable comparability and code of conduct laws, rules and regulations, as amended from time to time. For clarity and avoidance of ambiguity, IID is not a jurisdictional public utility to whom Section 205 or 206 of the Federal Power Act or FERC rules and regulations thereunder apply.

Article 22. Confidentiality

22.1 Confidentiality. Confidential Information shall include, without limitation, all information relating to a Party's technology, research and development, business affairs, and pricing, and any information supplied by any of the Parties to the other prior to the execution of this Agreement.

Information is Confidential Information only if it is clearly designated or marked in writing as confidential on the face of the document, or, if the information is conveyed orally or by inspection, if the Party providing the information orally informs the Parties receiving the information that the information is confidential.

If requested by any Party, the other Parties shall provide in writing, the basis for asserting that the information referred to in this Article 22 warrants confidential treatment, and the requesting Party may disclose such writing to the appropriate Governmental Authority. Each Party shall be responsible for the costs associated with affording confidential treatment to its information.

22.1.1 Term. During the term of this Agreement, and for a period of three (3) years after the expiration or termination of this Agreement, except as otherwise provided in this Article 22, each Party shall hold in confidence and shall not disclose to any person Confidential Information.

22.1.2 Scope. Confidential Information shall not include information that the receiving Party can demonstrate: (1) is generally available to the public other than as a result of a disclosure by the receiving Party; (2) was in the lawful possession of the receiving Party on a non-confidential basis before receiving it from the disclosing Party; (3) was supplied to the receiving Party without restriction by a third party, who, to the knowledge of the receiving Party after due inquiry, was under no obligation to the disclosing Party to keep such information confidential; (4) was independently developed by the receiving Party without reference to Confidential Information of the disclosing Party; (5) is, or becomes, publicly known, through no wrongful act or omission of the receiving Party or Breach of this Agreement; or (6) is required, in accordance with Article 22.1.7 of the Agreement, Order of Disclosure, to be disclosed by any Governmental Authority or is otherwise required to be disclosed by law or subpoena, or is necessary in any legal proceeding establishing rights and obligations under this Agreement.

Information designated as Confidential Information will no longer be deemed confidential if the Party that designated the information as confidential notifies the other Parties that it no longer is confidential.

22.1.3 Release of Confidential Information. No Party shall release or disclose Confidential Information to any other person, except to its Affiliates (limited by the Standards of Conduct requirements set forth in Part 358 of FERC's Regulations, 18 C.F.R. 358), subcontractors, employees, consultants, or to parties who may be or considering providing financing to or equity participation with Interconnection Customer, or to potential purchasers or assignees of Interconnection Customer, on a need-to-know basis in connection with this Agreement, unless such person has first been advised of the confidentiality provisions of this Article 22 and has agreed to comply with such provisions. Notwithstanding the foregoing, a Party providing Confidential Information to any person shall remain primarily responsible for any release of Confidential Information in contravention of this Article 22.

22.1.4 Rights. Each Party retains all rights, title, and interest in the Confidential Information that each Party discloses to the other Parties. The disclosure by each Party to the other Parties of Confidential Information shall not be deemed a waiver by a Party or any other person or entity of the right to protect the Confidential Information from public disclosure.

22.1.5 No Warranties. By providing Confidential Information, no Party makes any warranties or representations as to its accuracy or completeness. In addition, by supplying Confidential Information, no Party obligates itself to provide any particular information or Confidential Information to the other Parties nor to enter into any further agreements or proceed with any other relationship or joint venture.

22.1.6 Standard of Care. A Party shall use at least the same standard of care to protect Confidential Information it receives as it uses to protect its own Confidential Information from unauthorized disclosure, publication or dissemination. A Party may use Confidential Information solely to fulfill its obligations to the other Parties under this Agreement or its regulatory requirements.

22.1.7 Disclosure Required by Law or Order. If a court or a Government Authority or entity with the right, power, and apparent authority to do so requests or requires a Party, by subpoena, oral deposition, interrogatories, requests for production of documents, administrative order, or otherwise, to disclose Confidential Information, that Party shall provide the other Parties with prompt notice of such request(s) or requirement(s) so that the other Parties may seek an appropriate protective order or waive compliance with the terms of this Agreement. Notwithstanding the absence of a protective order or waiver, the Party may disclose such Confidential Information which, in the opinion of its counsel, the Party is legally compelled to disclose, including any Confidential Information that, in the opinion of IID's counsel, IID is legally compelled to disclose under California public record laws. A Party will use Reasonable Efforts to obtain reliable assurance that confidential treatment will be accorded any Confidential Information so furnished.

- 22.1.8 Termination of Agreement.** Upon termination of this Agreement for any reason, each Party shall, within ten (10) Calendar Days of receipt of a written request from another Party, use Reasonable Efforts to destroy, erase, or delete (with such destruction, erasure, and deletion certified in writing to the other Parties) or return to another Party, without retaining copies thereof, any and all written or electronic Confidential Information received from the other Party.
- 22.1.9 Remedies.** The Parties agree that monetary damages would be inadequate to compensate a Party for another Party's Breach of its obligations under this Article 22. Each Party accordingly agrees that the other Parties shall be entitled to equitable relief, by way of injunction or otherwise, if the first Party Breaches or threatens to Breach its obligations under this Article 22, which equitable relief shall be granted without bond or proof of damages, and the receiving Party shall not plead in defense that there would be an adequate remedy at law. Such remedy shall not be deemed an exclusive remedy for the Breach of this Article 22, but shall be in addition to all other remedies available at law or in equity. The Parties further acknowledge and agree that the covenants contained herein are necessary for the protection of legitimate business interests and are reasonable in scope. No Party, however, shall be liable for indirect, incidental, or consequential or punitive damages of any nature or kind resulting from or arising in connection with this Article 22.
- 22.1.10 Disclosure to FERC, its Staff, or a State.** Notwithstanding anything in this Article 22 to the contrary, and pursuant to 18 CFR section 1b.20, if FERC or its staff, during the course of an investigation or otherwise, requests information from one of the Parties that is otherwise required to be maintained in confidence pursuant to this Agreement, the Party shall provide the requested information to FERC or its staff, within the time provided for in the request for information. In providing the information to FERC or its staff, the Party must, consistent with 18 CFR section 388.112, request that the information be treated as confidential and non-public by FERC and its staff and that the information be withheld from public disclosure. Parties are prohibited from notifying the other Party to this Agreement prior to the release of the Confidential Information to FERC or its staff. The Party shall notify the other Parties to the Agreement when it is notified by FERC or its staff that a request to release Confidential Information has been received by FERC, at which time any of the Parties may respond before such information would be made public, pursuant to 18 CFR section 388.112. Requests from a state regulatory body conducting a confidential investigation shall be treated in a similar manner if consistent with the applicable state rules and regulations.
- 22.1.11** Subject to the exception in Article 22.1.10, Confidential Information shall not be disclosed by the other Parties to any person not employed or retained by the other Parties, except to the extent disclosure is (i) required by law; (ii) reasonably deemed by the disclosing Party to be required to be disclosed in connection with a dispute between or among the Parties, or the defense of litigation or dispute; (iii) otherwise permitted by consent of the other Parties, such consent not to be unreasonably withheld; or (iv) necessary to fulfill its obligations under this Agreement or as a transmission service provider or a Balancing Authority

including disclosing the Confidential Information to an RTO or ISO or to a regional or national reliability organization. The Party asserting confidentiality shall notify the other Party in writing of the information it claims is confidential. Prior to any disclosures of another Party's Confidential Information under this subparagraph, or if any third party or Governmental Authority makes any request or demand for any of the information described in this subparagraph, the disclosing Party agrees to promptly notify the other Party in writing and agrees to assert confidentiality and cooperate with the other Party in seeking to protect the Confidential Information from public disclosure by confidentiality agreement, protective order or other reasonable measures.

Article 23. Environmental Releases

23.1 Each Party shall notify the other Parties, first orally and then in writing, of the release of any Hazardous Substances, any asbestos or lead abatement activities, or any type of remediation activities related to the Large Generating Facility or the Interconnection Facilities, each of which may reasonably be expected to affect the other Party. The notifying Party shall: (i) provide the notice as soon as practicable, provided such Parties makes a good faith effort to provide the notice no later than twenty-four hours after such Party becomes aware of the occurrence; and (ii) promptly furnish to the other Parties copies of any publicly available reports filed with any Governmental Authorities addressing such events.

Article 24. Information Requirements

24.1 Information Acquisition. APS, on behalf of Transmission Owners, and Interconnection Customer shall submit specific information regarding the electrical characteristics of their respective facilities to each other as described below and in accordance with Applicable Reliability Standards.

24.2 Information Submission by APS, on behalf of Transmission Owners. The initial information submission by APS, on behalf of Transmission Owners, shall occur no later than one hundred eighty (180) Calendar Days prior to Trial Operation of a Project Phase and shall include Transmission System information necessary to allow Interconnection Customer to select equipment and meet any system protection and stability requirements, unless otherwise agreed to by the Parties. On a monthly basis APS, on behalf of Transmission Owners, shall provide Interconnection Customer and the CAISO a status report on the construction and installation of Transmission Owners' Interconnection Facilities and Network Upgrades, including, but not limited to, the following information: (1) progress to date; (2) a description of the activities since the last report (3) a description of the action items for the next period; and (4) the delivery status of equipment ordered.

24.3 Updated Information Submission by Interconnection Customer. The updated information submission by Interconnection Customer, including manufacturer information, shall occur no later than one hundred eighty (180) Calendar Days prior to the Trial Operation of a Project Phase. Interconnection Customer shall submit a completed copy of the Large Generating Facility data requirements contained in Appendix 1 to the LGIP. It shall also include any additional updates to information provided to APS and CAISO for the Interconnection Feasibility, Interconnection

Facilities Study, and the CAISO Phase II Interconnection Study, as applicable. Information in this submission shall be the most current Large Generating Facility design or expected performance data. Information submitted for stability models shall be compatible with APS's and the CAISO's standard models. If there is no compatible model, Interconnection Customer will work with a consultant mutually agreed to by the Parties to develop and supply a standard model and associated information.

If Interconnection Customer's data is materially different from what was originally provided to APS or the CAISO pursuant to the Interconnection Study Agreements between APS or the CAISO and Interconnection Customer, then APS or the CAISO, as applicable, will conduct appropriate studies to determine the impact on the Transmission System based on the actual data submitted pursuant to this Article 24.3. The Interconnection Customer shall not begin Trial Operation of a Project Phase until such studies are completed and all other applicable requirements of this Agreement are satisfied.

If Interconnection Customer's data is materially different from what was originally provided to IID by the CAISO or by the Interconnection Customer pursuant to the Affected System Study Agreement, then IID also shall have the right, but not the obligation, to conduct any appropriate Affected System Study necessary to determine the impact on its non-JPP transmission facilities based on the actual data submitted pursuant to this Article 24.3. To the extent IID exercises this right, Interconnection Customer shall not begin Trial Operation of a Project Phase until such studies are completed and all other applicable requirements of this Agreement are satisfied.

24.4 Information Supplementation. Prior to Trial Operation of a Project Phase, the Parties shall supplement their information submissions described above in this Article 24 with any and all "as-built" Large Generating Facility information or "as-tested" performance information that differs from the initial submissions or, alternatively, written confirmation that no such differences exist. The Interconnection Customer shall conduct tests on the Large Generating Facility as required by Good Utility Practice such as an open circuit "step voltage" test on the Large Generating Facility to verify proper operation of the Large Generating Facility's automatic voltage regulator.

Unless otherwise agreed, the test conditions shall include: (1) Large Generating Facility at synchronous speed; (2) automatic voltage regulator on and in voltage control mode; and (3) a five percent change in Large Generating Facility terminal voltage initiated by a change in the voltage regulators reference voltage. Interconnection Customer shall provide validated test recordings showing the responses of Large Generating Facility terminal and field voltages. In the event that direct recordings of these voltages is impractical, recordings of other voltages or currents that mirror the response of the Large Generating Facility's terminal or field voltage are acceptable if information necessary to translate these alternate quantities to actual Large Generating Facility terminal or field voltages is provided. Large Generating Facility testing shall be conducted and results provided to APS and the CAISO at the request of APS and the CAISO.

Subsequent to the Commercial Operation Date for a Project Phase, Interconnection Customer shall provide APS and the CAISO any information changes due to equipment replacement, repair, or adjustment. APS, on behalf of Transmission Owners, shall provide Interconnection Customer any information changes due to equipment

replacement, repair or adjustment in the directly connected substation or any adjacent Transmission Owners' substation that may affect Interconnection Customer's Interconnection Facilities equipment ratings, protection or operating requirements. The Parties shall provide such information pursuant to Article 5.19.

Article 25. Information Access and Audit Rights

- 25.1 Information Access.** Each Party (the "disclosing Party") shall make available to the other Parties information that is in the possession of the disclosing Party and is necessary in order for the other Parties to: (i) verify the costs incurred by the disclosing Party for which another Party is responsible under this Agreement; and (ii) carry out its obligations and responsibilities under this Agreement. The Parties shall not use such information for purposes other than those set forth in this Article 25.1 and to enforce their rights under this Agreement. Nothing in this Article 25 shall obligate a Party to make available to another Party any third party information in its possession or control if making such third party information available would violate a Tariff or other legal restriction on the use or disclosure of such third party information.
- 25.2 Reporting of Non-Force Majeure Events.** Each Party (the "notifying Party") shall notify the other Parties when the notifying Party becomes aware of its inability to comply with the provisions of this Agreement for a reason other than a Force Majeure event. The Parties agree to cooperate with each other and provide necessary information regarding such inability to comply, including the date, duration, reason for the inability to comply, and corrective actions taken or planned to be taken with respect to such inability to comply. Notwithstanding the foregoing, notification, cooperation or information provided under this article shall not entitle the Parties receiving such notification to allege a cause for anticipatory breach of this Agreement.
- 25.3 Audit Rights.** Subject to the requirements of confidentiality under Article 22 of this Agreement, each Party shall have the right, during normal business hours, and upon prior reasonable notice to the other Party, to audit at its own expense the other Party's accounts and records pertaining to either such Party's performance or either such Party's satisfaction of obligations under this Agreement. Such audit rights shall include audits of the other Party's costs pertaining to such Party's performance or satisfaction of obligations owned to the other Party under this Agreement, calculation of invoiced amounts, APS's and the CAISO's efforts to allocate responsibility for the provision of reactive support to the Transmission System, Transmission Owners' and the CAISO's efforts to allocate responsibility for interruption or reduction of generation on the Transmission System, and each Party's actions in an Emergency Condition. Any audit authorized by this article shall be performed at the offices where such accounts and records are maintained and shall be limited to those portions of such accounts and records that relate to each such Party's performance and satisfaction of obligations under this Agreement. Each such Party shall keep such accounts and records for a period equivalent to the audit rights periods described in Article 25.4. Notwithstanding anything to the contrary in Article 25, each Party's rights to audit APS's, IID's, SDG&E's or the CAISO's accounts and records shall be subject to their respective Tariffs.
- 25.4 Audit Rights Periods.**

25.4.1 Audit Rights Period for Construction-Related Accounts and Records. Accounts and records related to the design, engineering, procurement, and construction of Transmission Owners' Interconnection Facilities and Network Upgrades shall be subject to audit for a period of twenty-four months following issuances of final invoices in accordance with Article 12.2.

25.4.2 Audit Rights Period for All Other Accounts and Records. Accounts and records related to either Party's performance or satisfaction of all obligations under this Agreement other than those described in Article 25.4.1 shall be subject to audit as follows: (i) for an audit relating to cost obligations, the applicable audit rights period shall be twenty-four months after the auditing Party's receipt of an invoice giving rise to such cost obligations; and (ii) for an audit relating to all other obligations, the applicable audit rights period shall be twenty-four months after the event for which the audit is sought.

25.5 Audit Results. If an audit by a Party determines that an overpayment or an underpayment has occurred, a notice of such overpayment or underpayment shall be given to the other Parties together with those records from the audit which support such determination.

Article 26. Subcontractors

26.1 General. Nothing in this Agreement shall prevent a Party from utilizing the services of any subcontractor as it deems appropriate to perform its obligations under this Agreement; provided, however, that each Party shall require its subcontractors to comply with all applicable terms and conditions of this Agreement in providing such services and each Party shall remain primarily liable to the other Party for the performance of such subcontractor.

26.2 Responsibility of Principal. The creation of any subcontract relationship shall not relieve the hiring Party of any of its obligations under this Agreement. The hiring Party shall be fully responsible to the other Parties for the acts or omissions of any subcontractor the hiring Party hires as if no subcontract had been made; provided, however, that in no event shall Transmission Owners or the CAISO be liable for the actions or inactions of Interconnection Customer or its subcontractors with respect to obligations of Interconnection Customer under Article 5 of this Agreement. Any applicable obligation imposed by this Agreement upon the hiring Party shall be equally binding upon, and shall be construed as having application to, any subcontractor of such Party.

26.3 No Limitation by Insurance. The obligations under this Article 26 will not be limited in any way by any limitation of subcontractor's insurance.

Article 27. Disputes

Disputes between the Interconnection Customer, CAISO and/or SDG&E arising out of requirements of the CAISO Tariff shall be settled in accordance with the provisions of Article 13 of the CAISO Tariff, except that references to the CAISO Tariff in such Article 13 of the CAISO Tariff shall be read as references to this Agreement. Disputes between the Interconnection

Customer and IID arising out of the Affected System Study Agreement or Affected System Construction and Operation Agreement shall be resolved in accordance with the provisions of Section 13.5 of the Generation Interconnection Procedures in IID's Tariff. All other disputes shall be resolved as follows:

27.1 Submission. In the event a Party has a dispute, or asserts a claim, that arises out of or in connection with this Agreement or its performance, such Party (the "disputing Party") shall provide the other Parties with written notice of the dispute or claim ("Notice of Dispute"). Such dispute or claim shall be referred to a designated senior representative of each Party for resolution on an informal basis as promptly as practicable after receipt of the Notice of Dispute by the other Parties. In the event the designated representatives are unable to resolve the claim or dispute through unassisted or assisted negotiations within thirty (30) Calendar Days of the other Parties' receipt of the Notice of Dispute, such claim or dispute may, upon mutual agreement of the Parties, be submitted to arbitration and resolved in accordance with the arbitration procedures set forth below. In the event the Parties do not agree to submit such claim or dispute to arbitration, any Party may exercise whatever rights and remedies it may have in equity or at law consistent with the terms of this Agreement.

27.2 External Arbitration Procedures. Any arbitration initiated under this Agreement shall be conducted before a single neutral arbitrator appointed by the Parties, or in the absence of such appointment, by selection by the American Arbitration Association. The arbitrator shall be knowledgeable in electric utility matters, including electric transmission and bulk power issues, and shall not have any current or past substantial business or financial relationships with any party to the arbitration (except prior arbitration). The arbitrator shall provide each of the Parties an opportunity to be heard and, except as otherwise provided herein, shall conduct the arbitration in accordance with the Commercial Arbitration Rules of the American Arbitration Association ("Arbitration Rules") and any applicable FERC regulations; provided, however, in the event of a conflict between the Arbitration Rules and the terms of this Article 27, the terms of this Article 27 shall prevail.

27.3 Arbitration Decisions. Unless otherwise agreed by the Parties, the arbitrator shall render a decision within ninety (90) Calendar Days of appointment and shall notify the Parties in writing of such decision and the reasons therefor. The arbitrator shall be authorized only to interpret and apply the provisions of this Agreement and shall have no power to modify or change any provision of this Agreement in any manner. The decision of the arbitrator shall be final and binding upon the Parties, and judgment on the award may be entered in any court having jurisdiction. The decision of the arbitrator may be appealed solely on the grounds that the conduct of the arbitrator, or the decision itself, violated the standards set forth in the Federal Arbitration Act or the Administrative Dispute Resolution Act. The final decision of the arbitrator must also be filed with FERC if it affects jurisdictional rates, terms and conditions of service, Interconnection Facilities, or Network Upgrades.

27.4 Costs. Each Party shall be responsible for its own costs incurred during the arbitration process and for its per capita share of the cost of the arbitrator.

Article 28. Representations, Warranties, and Covenants

28.1 General. Each Party makes the following representations, warranties and covenants:

28.1.1 Good Standing. Such Party is duly organized, validly existing and in good standing under the laws of the state in which it is organized, formed, or incorporated, as applicable; that it is qualified to do business in the state or states in which the Large Generating Facility, Interconnection Facilities and Network Upgrades owned by such Party, as applicable, are located; and that it has the corporate power and authority to own its properties, to carry on its business as now being conducted and to enter into this Agreement and carry out the transactions contemplated hereby and perform and carry out all covenants and obligations on its part to be performed under and pursuant to this Agreement.

28.1.2 Authority. Such Party has the right, power and authority to enter into this Agreement, to become a Party hereto and to perform its obligations hereunder. This Agreement is a legal, valid and binding obligation of such Party, enforceable against such Party in accordance with its terms, except as the enforceability thereof may be limited by applicable bankruptcy, insolvency, reorganization or other similar laws affecting creditors' rights generally and by general equitable principles (regardless of whether enforceability is sought in a proceeding in equity or at law).

28.1.3 No Conflict. The execution, delivery and performance of this Agreement does not violate or conflict with the organizational or formation documents, or bylaws or operating agreement, of such Party, or any judgment, license, permit, order, material agreement or instrument applicable to or binding upon such Party or any of its assets.

28.1.4 Consent and Approval. Such Party has sought or obtained, or, in accordance with this Agreement will seek or obtain, each consent, approval, authorization, order, or acceptance by any Governmental Authority in connection with the execution, delivery and performance of this Agreement, and it will provide to any Governmental Authority notice of any actions under this Agreement that are required by Applicable Laws and Regulations.

Article 29. Joint Operating Committee

29.1 Joint Operating Committee. APS, on behalf of the Transmission Owners, shall constitute a Joint Operating Committee to coordinate operating and technical considerations of Interconnection Service. At least six (6) months prior to the expected Initial Synchronization Date, APS and Interconnection Customer shall appoint one representative and one alternate to the Joint Operating Committee. APS and Interconnection Customer shall notify each other of its appointment in writing. Such appointments may be changed at any time by similar notice. The Joint Operating Committee shall meet as necessary, but not less than once each calendar year, to carry out the duties set forth herein. The Joint Operating Committee shall hold a meeting at the request of any Party, at a time and place agreed upon by the representatives of the Joint Operating Committee. The Joint Operating Committee shall perform all of its duties consistent with the provisions of this Agreement. Each Party shall cooperate in providing to the Joint Operating Committee all information required in the performance of the Joint Operating Committee's duties. All decisions and agreements, if any, made by the Joint

Operating Committee, shall be evidenced in writing. The duties of the Joint Operating Committee shall include the following:

- 29.1.1** Establish data requirements and operating record requirements.
- 29.1.2** Review the requirements, standards, and procedures for data acquisition equipment, protective equipment, and any other equipment or software.
- 29.1.3** Annually review the one (1) year forecast of maintenance and planned outage schedules of Transmission Owners' and Interconnection Customer's facilities at the Point of Interconnection.
- 29.1.4** Coordinate the scheduling of maintenance and planned outages on the Interconnection Facilities, the Large Generating Facility and other facilities that impact the normal operation of the interconnection of the Large Generating Facility to the Transmission System.
- 29.1.5** Ensure that information is being provided by each Party regarding equipment availability.
- 29.1.6** Perform such other duties as may be conferred upon it by mutual agreement of the Parties.

Article 30. Miscellaneous

- 30.1 Binding Effect.** This Agreement and the rights and obligations hereof, shall be binding upon and shall inure to the benefit of the successors and assigns of the Parties hereto.
- 30.2 Conflicts.** In the event of a conflict between the body of this Agreement and any attachment, appendices or exhibits hereto, the terms and provisions of the body of this Agreement shall prevail and be deemed the final intent of the Parties.
- 30.3 Rules of Interpretation.** This Agreement, unless a clear contrary intention appears, shall be construed and interpreted as follows: (1) the singular number includes the plural number and vice versa; (2) reference to any person includes such person's successors and assigns but, in the case of a Party, only if such successors and assigns are permitted by this Agreement, and reference to a person in a particular capacity excludes such person in any other capacity or individually; (3) reference to any agreement (including this Agreement), document, instrument or tariff means such agreement, document, instrument, or tariff as amended or modified and in effect from time to time in accordance with the terms thereof and, if applicable, the terms hereof; (4) reference to any Applicable Laws and Regulations means such Applicable Laws and Regulations as amended, modified, codified, or reenacted, in whole or in part, and in effect from time to time, including, if applicable, rules and regulations promulgated thereunder; (5) unless expressly stated otherwise, reference to any Article, Section or Appendix means such Article of this Agreement or such Appendix to this Agreement, or such Section to the applicable Large Generator Interconnection Procedures or such Appendix to the applicable Large Generator Interconnection Procedures, as the case may be; (6) "hereunder", "hereof", "herein", "hereto" and words of similar import shall be deemed references to this Agreement as a whole and not to any particular Article or other

provision hereof or thereof; (7) "including" (and with correlative meaning "include") means including without limiting the generality of any description preceding such term; and (8) relative to the determination of any period of time, "from" means "from and including", "to" means "to but excluding" and "through" means "through and including".

30.4 Entire Agreement. This Agreement, including all Appendices and Schedules attached hereto, constitutes the entire agreement among all of the Parties with reference to the subject matter hereof, and supersedes all prior and contemporaneous understandings or agreements, oral or written, among the Parties with respect to the subject matter of this Agreement. There are no other agreements (other than the Affected System Study Agreement and Affected System Construction and Operation Agreement), representations, warranties, or covenants which constitute any part of the consideration for, or any condition to, any Party's compliance with its obligations under this Agreement.

30.5 No Third Party Beneficiaries. This Agreement is not intended to and does not create rights, remedies, or benefits of any character whatsoever in favor of any persons, corporations, associations, or entities other than the Parties, and the obligations herein assumed are solely for the use and benefit of the Parties, their successors in interest and, where permitted, their assigns.

30.6 Waiver. The failure of a Party to this Agreement to insist, on any occasion, upon strict performance of any provision of this Agreement will not be considered a waiver of any obligation, right, or duty of, or imposed upon, such Party.

Any waiver at any time by either Party of its rights with respect to this Agreement shall not be deemed a continuing waiver or a waiver with respect to any other failure to comply with any other obligation, right, duty of this Agreement. Termination or Default of this Agreement for any reason by Interconnection Customer shall not constitute a waiver of Interconnection Customer's legal rights to obtain an interconnection from Transmission Owner. Any waiver of this Agreement shall, if requested, be provided in writing.

30.7 Headings. The descriptive headings of the various Articles of this Agreement have been inserted for convenience of reference only and are of no significance in the interpretation or construction of this Agreement.

30.8 Multiple Counterparts. This Agreement may be executed in two or more counterparts, each of which is deemed an original but all constitute one and the same instrument.

30.9 Amendment. The Parties may by mutual agreement amend this Agreement by a written instrument duly executed by all the Parties. Such amendment shall become effective and a part of this Agreement upon satisfaction of all Applicable Laws and Regulations.

30.10 Modification by the Parties. The Parties may by mutual agreement amend the Appendices to this Agreement by a written instrument duly executed by the Parties. Such amendment shall become effective and a part of this Agreement upon satisfaction of all Applicable Laws and Regulations.

- 30.11 Reservation of Rights.** FERC-jurisdictional Transmission Owners and the CAISO shall have the right to make a unilateral filing with FERC to modify this Agreement with respect to any rates, terms and conditions, charges, classifications of service, rule or regulation under section 205 or any other applicable provision of the Federal Power Act and FERC's rules and regulations thereunder, and Interconnection Customer shall have the right to make a unilateral filing with FERC to modify this Agreement pursuant to section 206 or any other applicable provision of the Federal Power Act and FERC's rules and regulations thereunder; provided that another Party shall have the right to protest any such filing by the other Party and to participate fully in any proceeding before FERC in which such modifications may be considered. Nothing in this Agreement shall limit the rights of the Parties or of FERC under sections 205 or 206 of the Federal Power Act and FERC's rules and regulations thereunder, except to the extent that the Parties otherwise mutually agree as provided herein. Notwithstanding the foregoing, IID shall not be subject, without its mutual consent, to a modification of its rights and obligations under this Agreement through a unilateral filing by another Party with FERC and, as applied to IID, the Effective Date of a modified Agreement shall not commence until the modified Agreement is actually executed by IID, either voluntarily or pursuant to a lawful order issued by FERC in accordance with Sections 210 and 212 of the Federal Power Act.
- 30.12 No Partnership.** This Agreement shall not be interpreted or construed to create an association, joint venture, agency relationship, or partnership among the Parties or to impose any partnership obligation or partnership liability upon any Party. No Party shall have any right, power or authority to enter into any agreement or undertaking for, or act on behalf of, or to act as or be an agent or representative of, or to otherwise bind, another Party.
- 30.13 Joint and Several Obligations.** Except as otherwise provided in this Agreement, the obligations of each Transmission Owner, the CAISO and the Interconnection Customer are several, and are neither joint nor joint and several.

[REMAINDER OF PAGE INTENTIONALLY LEFT BLANK]

IN WITNESS WHEREOF, the Parties have executed this Agreement in multiple originals, each of which shall constitute and be an original effective Agreement among the Parties.

Arizona Public Service Company

By: John R. Lucas

Name: John R. Lucas

Title: MANAGER

Date: 5/27/10

Imperial Irrigation District

By: _____

Name: _____

Title: _____

Date: _____

San Diego Gas & Electric Company

By: _____

Name: _____

Title: _____

Date: _____

California Independent System Operator Corporation

By: _____

Name: _____

Title: _____

Date: _____

Agua Caliente Solar, LLC

By: _____

Name: _____

Title: _____

Date: _____

North Gila River Development, LLC

By: _____

Name: _____

Title: _____

Date: _____

IN WITNESS WHEREOF, the Parties have executed this Agreement in multiple originals, each of which shall constitute and be an original effective Agreement among the Parties.

Arizona Public Service Company

By: _____
Name: _____
Title: _____
Date: _____

Imperial Irrigation District

By: _____
Name: _____
Title: _____
Date: _____

San Diego Gas & Electric Company

By: _____
Name: _____
Title: _____
Date: _____

California Independent System Operator Corporation

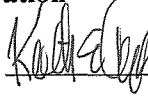
By:  _____
Name: _____
Title: KEITH E. CASEY PH.D. VICE PRESIDENT
MARKET & INFRASTRUCTURE DEVELOPMENT
Date: 5/19/10

Agua Caliente Solar, LLC

By: _____
Name: _____
Title: _____
Date: _____

North Gila River Development, LLC

By: _____
Name: _____
Title: _____
Date: _____

IN WITNESS WHEREOF, the Parties have executed this Agreement in multiple originals, each of which shall constitute and be an original effective Agreement among the Parties.

Arizona Public Service Company

By: _____
Name: _____
Title: _____
Date: _____

Imperial Irrigation District

By: _____
Name: _____
Title: _____
Date: _____

San Diego Gas & Electric Company

By: _____
Name: _____
Title: _____
Date: _____

California Independent System Operator Corporation

By: _____
Name: _____
Title: _____
Date: _____

Agua Caliente Solar, LLC

By: Frank De Rosa
Name: Frank De Rosa
Title: President
Date: May 27, 2010

North Gila River Development, LLC

By: Frank De Rosa
Name: Frank De Rosa
Title: President
Date: May 27, 2010

Appendices

Appendix A-1

Interconnection Facilities, JPP Network Upgrades, and Distribution Upgrades for Phase A of the Interconnection Project

The Generating Facility will have a total rated capacity of 500 MW based on both Phase A and Phase B achieving Commercial Operation. This Appendix A-1 addresses Phase A of the Generating Facility and Appendix A-2 addresses Phase B of the Generating Facility.

1. Phase A of the Generating Facility Description:

Phase A of the Generating Facility is located on private land and consists of a photovoltaic solar field, inverters, a medium voltage collection system, an operations and maintenance building, a 34.5kV/500kV substation and various other facilities. Phase A of the Generating Facility will consist of no more than 290 MW (net) of solar photovoltaic units installed at the site.

The Interconnection Customer Interconnection Facilities include a new substation which will contain two (2) 34.5kV/500kV step-up transformers (“SUTs”). The SUTs are combined through a common high voltage bus that is connected to one single 500 kV interconnection line. Phase A of the Generating Facility is connected to the Transmission Owners’ 500kV switchyard (“Switchyard”) via the single 500kV interconnection line. The substation is located in close proximity to the Switchyard.

2. Point of Interconnection:

The Point of Interconnection for Phase A of the Generating Facility is the Switchyard. See Appendix C – Diagram.

3. Power Injection Limitation at the Point of Interconnection:

The maximum allowable injection of power into the Switchyard at the Point of Interconnection for Phase A of the Generating Facility shall be 290 MW.

4. Point of Change of Ownership:

The Point of Change of Ownership demarcation point of the high voltage conductors and static wires will be the first designed dead end structure outside of the Switchyard fence. The Point of Change of Ownership will be at the line jumper connection point on the Transmission Owners’ dead-ended conductor. Interconnection Customer will provide, per APS specifications, required materials, including foundations, steel structures, insulators, attachment hardware and dead-end connectors to install and terminate conductors at this structure from Switchyard. APS will supply and install conductors to this point of attachment. Interconnection Customer will provide and install materials, including insulators, attachment hardware, conductors, dead-end connectors, and jumper connections, from the Generating Facility substation to the termination point on the dead end structure. See Appendix C – Diagram.

If overhead communication cable is utilized, the interconnection and ownership demarcation point will be a splice point located on the first designed dead-end structure for the high voltage conductor outside of the Switchyard fence. Interconnection Customer will provide required materials for attachment of cable to structures to this point from the Switchyard. APS will provide communication cable to this point. Interconnection Customer will be responsible for providing materials and connection to APS termination at this location.

If underground communication cable is utilized, the interconnection and ownership demarcation point will be a manhole located outside of the Switchyard fence. APS will provide manhole and other materials required to install cable from the Switchyard. Interconnection Customer will be responsible for providing materials and connection to APS termination at this location.

5. Interconnection Facilities:

(a) Interconnection Customer's Interconnection Facilities

The Interconnection Customer's Interconnection Facilities consists of a 34.5/500kV Generating Facility substation, support structures, including the two sided dead end structure, and a generation tie line from the Generating Facility substation to the Point of Change of Ownership with the Transmission Owner's Interconnection Facilities. The Interconnection Customer's Interconnection Facilities also includes all metering equipment required to comply with the CAISO Tariff.

The following is an equipment list from the Interconnection Customer's Interconnection Facilities:

2 – 34.5kV/500kV step up transformers
Revenue meter
Shunt capacitors
Transmission structure at ownership change

(b) Transmission Owners' Interconnection Facilities

The Transmission Owners' Interconnection Facilities consist of the facilities between the Point of Change of Ownership and Point of Interconnection in the Switchyard. This consists of one 500 kV disconnect switch, and a span of 500kV conductor. The protection equipment for Phase A of the Interconnection Project is also included in Transmission Owners' Interconnection Facilities as is the metering equipment for the interconnection.

The following is an equipment list comprising the Transmission Owners' Interconnection Facilities:

Intertie meter
1 500kV, 3000A, Vertical Break Switch
Conductor
Relays

6. JPP Network Upgrades:

(a) Switchyard

APS will design and construct the new 500kV Switchyard. The Switchyard will be designed as a breaker-and-a-half configuration to accommodate future plans of the Transmission Owners and

potential future third-party generation developers. Initially, three 500kV breakers and supporting bus work and structures will be built to accommodate the line terminations from (i) Hassayampa, (ii) North Gila and (iii) the Generating Facility. This initial phase of the Switchyard will include 500kV bus work and disconnect switches to limit outages for future installations.

The Switchyard will also include a control enclosure for the housing of the critical protective relaying and the Supervisory Control and Data Acquisition (SCADA) system. The control room building will include sufficient battery capacity to reliably operate the Switchyard as part of the interconnected Transmission System. Redundant communication will be provided by a new 100-foot microwave tower constructed to support sufficient dishes and antenna to provide reliable integration of the Generating Facility into the APS communications network. No fiber optic lines are planned for Phase A of the Interconnection Project.

The Switchyard site will be secured with a minimum 7-foot tall, chain link metal-fabric security fence with 1-foot barbed wire or razor wire on top.

The following is an equipment list from the Switchyard portion of the JPP Network Upgrades:

Breakers - 3 500kV, 3000A, 63kA

Switches - 10 500kV, 3000A, Vertical Break

1 500kV 3000A, Vertical Reach

Current Transformers (CTs) - 3 500kV, Extended Range Metering Accuracy 1500/5A

CC Voltage Transformers (11)

A fourth breaker will be required when the Switchyard is converted from a ring bus alignment to a breaker and one half arrangement. The timing for this change will be driven by a fifth termination into the Switchyard.

(b) Transmission Line

The transmission interconnection will be a loop-in of the Switchyard to the existing Hassayampa – North Gila #1 500 kV line with the end points being new turning structures located within the existing 500kV line rights-of-way and the dead-end structures located within the Switchyard.

The following is an equipment/material list from the transmission line portion of the JPP Network Upgrades:

2 500kV Lattice Tower structures

Conductor

7. Stand-Alone JPP Network Upgrades: None

8. Transmission Owners' Interconnection Facilities and JPP Network Upgrade Cost Summary:

Cost Estimate (2010 dollars)

Element	Cost	Transmission Owner Share		
		APS	IID	SDG&E
Transmission Owners' Interconnection Facilities				
500kV conductor tie line	611,000	0	0	0
Disconnect Switches	150,000	0	0	0
Protection Equipment	400,000	0	0	0
Contingency	232,000	0	0	0
1) Subtotal	1,393,000	0	0	0
JPP Network Upgrades				
Transmission	1,985,000	218,350	253,683	1,512,967
Switchyard	14,700,000	1,617,000	1,878,660	11,204,340
Telecommunications	75,000	8,250	9,585	57,165
Relay changes at Hassayampa	136,000	14,960	17,381	103,659
Relay changes at North Gila	136,000	14,960	17,381	103,659
Deferred breaker	810,000	89,100	103,518	617,382
Contingency	3,568,000	392,480	455,990	2,719,530
2) Subtotal JPP Network Upgrades	21,410,000	2,355,100	2,736,198	16,318,702
3) Interconnection Project Cost (for cash flow and financial security) (lines 1 & 2)	22,803,000	2,508,330	2,914,223	17,380,447
4) Interconnection Customer Contributions to Network Upgrades (real estate, environmental, and rough grading)	1,173,000	129,030	149,909	894,060
5) Total Network Upgrades (for reimbursement to Agua Caliente Solar, LLC) (lines 2 & 4)	22,583,000	2,484,130	2,886,107	17,212,763

9. Estimate of Monthly Incurred Costs for the Transmission Owners' Interconnection Facilities and JPP Network Upgrades:

An estimate of the monthly incurred costs is shown below.

Month	Estimated Cost by Month
Through April 2010	\$240,168
May 2010	\$0
June 2010	\$0
July 2010	\$486,924
August 2010	\$0
September 2010	\$0
October 2010	\$863,108
November 2010	\$863,108
December 2010	\$863,108
January 2011	\$5,305,720
February 2011	\$5,305,720
March 2011	\$5,305,720
April 2011	\$337,376
May 2011	\$337,376
June 2011	\$337,376
July 2011	\$348,120
August 2011	\$348,120
September 2011	\$348,120
October 2011	\$119,108
November 2011	\$119,108
December 2011	\$119,108
January 2012	\$1,155,672
Total	\$22,803,000

10. Invoicing and JPP Network Upgrade Repayment:

Invoices issued by APS on behalf of the Transmission Owners pursuant to Articles 12.1 and 12.2 of this Agreement for Phase A of the Generating Facility shall include the cumulative balance invoiced to date for the JPP Network Upgrades (including the actual costs for Network Upgrades incurred under the E&P Agreement) and the allocation of such balance to the Ownership Interests.

Within thirty (30) Calendar Days of the Commercial Operation Date for a Project Phase, APS, on behalf of the Transmission Owners, shall provide the Parties with a statement which indicates the

Ownership Share of each of the Transmission Owners in the cost of the Network Upgrades which are to be repaid in accordance with the provisions of Article 11.4.2 of this Agreement.

- (a) SDG&E Share: Interconnection Customer and SDG&E have agreed that SDG&E shall make the repayment provided for in Article 11.4.2 of this Agreement by making a cash payment to Agua Caliente Solar, LLC within sixty (60) Calendar Days of the Commercial Operation Date of each Project Phase.
- (b) APS Share: APS shall make the repayment provided for in Article 11.4.1 of this Agreement to Agua Caliente Solar, LLC in accordance with the terms of this Agreement.
- (c) IID Share: IID shall make the repayment provided for in Article 11.4.3 of this Agreement to Agua Caliente Solar, LLC in accordance with the terms of this Agreement.

11. Distribution Upgrades: NONE

12. Maintenance, Repair, and Replacement Charges:

The Interconnection Customer shall be responsible for actual costs incurred by APS, on behalf of the Transmission Owners, applicable to the maintenance, repair and replacement of the Transmission Owners' Interconnection Facilities, including but not limited to: the 500 kV disconnect switches, protection equipment for the Interconnection Customer's Interconnection Facilities, metering including CTs and PTs and communications equipment and all associated equipment (see Appendix C, Diagram). A good faith non-binding estimate of annual cost, for budgetary purposes only, is:

Estimate = \$ 1,000 per year

\$1,000 annually covers:

- Two inspections per year
- Relay maintenance (estimated at every 4-6 years)
- Disconnect switch maintenance (estimated at every 4-6 years)

Additional actual costs will be charged for:

- Emergency maintenance and repair work
- Replacement of failed or failing equipment

13. Transition from E&P Agreement:

The Parties recognize that some design and long lead-time procurement work for the interconnection of the Large Generating Facility to the JPP was done pursuant to the E&P Agreement entered into by APS, on behalf of the Transmission Owners, and the Interconnection Customer. In order to provide for a smooth transition between work done under the E&P Agreement and this Agreement, the Parties agree :

- (a) **Accounting Transition.** APS, on behalf of the Transmission Owners, shall calculate whether the Interconnection Customer has paid more or less than it owes under the terms of the E&P Agreement as of the Effective Date of this Agreement. If the Interconnection Customer paid more than it owes, APS, on behalf of the Transmission Owners, shall apply a credit to reduce the amount of the payments required under Article 12.1 of this Agreement for the Transmission Owners' Interconnection Facilities and JPP Network Upgrades. If the Interconnection Customer has paid less than it owes, the Interconnection Customer shall pay the amount due as if it were incurred for engineering and procurement work conducted pursuant to this Agreement, in

accordance with Article 12.1 of this Agreement, for the Transmission Owners' Interconnection Facilities and JPP Network Upgrades.

- (b) **Estimate of Total Interconnection Customer Payments.** In accordance with the Milestone Schedule in Appendix B-1, APS, on behalf of the Transmission Owners, shall provide an estimate of the total amount the Interconnection Customer paid under the E&P Agreement as of the Effective Date of this Agreement. This estimate shall be applied as a credit toward the amount of financial security due from the Interconnection Customer pursuant to Article 11.5 of this Agreement and Section 15 of this Appendix A-1 for the Transmission Owners' Interconnection Facilities and JPP Network Upgrades.
- (c) **Letter of Credit.** If the Interconnection Customer has posted a letter of credit or other financial security under the terms of the E&P Agreement, the letter of credit or other financial security shall be returned to Interconnection Customer as of the date the Interconnection Customer posts all of the financial security required in accordance with the terms of Article 11.5 of this Agreement and Section 14 of this Appendix A-1 for the Transmission Owners' Interconnection Facilities and JPP Network Upgrades.

14. Provision of Security:

- (a) **Initial Estimate of Financial Security to be Posted:** The amount available to be drawn under any credit support for the Transmission Owners' Interconnection Facilities and JPP Network Upgrades required to interconnect Phase A of the Generating Facility shall be:

APS Share (11.00%)	\$2,508,330
IID Share (12.78%)	\$2,914,223
Subtotal of APS and IID shares (23.78%)	\$5,422,553
SDG&E Share (76.22%)	\$17,380,447
TOTAL (100%)	\$22,803,000

- (b) **Adjustment for Amounts Paid under E&P Agreement:** The initial estimate of the financial security provided in Section 14(a) of this Appendix A-1 shall be reduced by each of the Transmission Owner's proportional shares of the estimated total Interconnection Customer payments made under the E&P Agreement. When APS, on behalf of the Transmission Owners, provides an estimate of the Interconnection Customer's total payments under the E&P Agreement pursuant to Section 13(b) of this Appendix A-1, it shall provide to the Interconnection Customer and the other Transmission Owners an adjusted estimate of the financial security to be posted.
- (c) **Posting:** The Interconnection Customer shall provide financial security for the Transmission Owners' Interconnection Facilities and JPP Network Upgrades no later than the milestone date specified in Appendix B-1 in accordance with Article 11.5 of this Agreement. With respect to the financial security for the APS and IID shares, Interconnection Customer shall post with APS, on behalf of APS and IID, the adjusted amount for both the APS and IID shares provided pursuant to Section 14(b) of this Appendix A-1 in the form of one security instrument.

With respect to the Interconnection Financial Security for SDG&E, SDG&E already holds Interconnection Financial Security for Phase A of the Generating Facility pursuant to the CAISO

Tariff. As of the date of signing of this Agreement, this security consists of two irrevocable letters of credit for the benefit of Agua Caliente Solar LLC. One of these letters, in the amount of \$5.8 million, has been posted to cover a portion of the Interconnection Customer's share of Network Upgrades. The other, in the amount of \$228,600 has been posted to cover a portion of the Transmission Owners' Interconnection Facilities. The letter of credit for the larger amount currently posted will terminate in accordance with its terms as of October 30, 2010, and the letter of credit for the smaller amount will terminate in accordance with its terms on October 30, 2010. Pursuant to the terms of the CAISO Tariff, these letters of credit must be replaced before they terminate; failure to do so shall provide grounds for termination of this Agreement as provided in Articles 2.3 and 11.5 of this Agreement.

It is possible that the amount of Interconnection Financial Security which the Interconnection Customer was previously required to post may be reduced by order of FERC as a result of litigation pending in Docket No. EL10-15. Regardless of any developments in that proceeding, Interconnection Customer will post the full amount of financial security as required by this Agreement for Phase A of the Generating Facility.

Under this Agreement the total amount the Interconnection Customer shall post no later than the milestone due date specified in Appendix B-1 shall be the adjusted amount for the SDG&E share provided pursuant to Section 14(b) of this Appendix A-1. If Interconnection Financial Security is to be provided before October 31, 2010, SDG&E agrees that the initial Interconnection Financial Security posted with SDG&E shall be replaced with new Interconnection Financial Security posted in accordance with the terms of this Agreement for the total adjusted amount for the SDG&E share provided pursuant to Section 14(b) of this Appendix A-1. SDG&E further agrees that it shall return the original Interconnection Financial Security and shall take no action to enforce its security rights, if any, under the existing Interconnection Financial Security once Interconnection Customer has posted new Interconnection Financial Security in accordance with the terms of this Agreement.

The Parties agree that the Interconnection Customer shall be allowed to make substitutions of the security posted under this Agreement so long as the new security posted is reasonably acceptable to the Transmission Owners, as provided for in Article 11.5 of this Agreement, and in the amount required by this Agreement.

- (d) Reduction of Amount of Security:** Interconnection Customer shall make arrangements for financial security that provide for periodic reduction of the amount of the financial security upon receipt of instructions from APS, acting on behalf of the Transmission Owners. APS, on behalf of the Transmission Owners, shall provide periodic notices of reductions in the amount of the financial security required to be held to the financial institution(s) the Interconnection Customer selects to hold the financial security. APS shall provide such notices to the financial institution holding the security for the APS and IID shares in accordance with the arrangements made by the Interconnection Customer with the financial institution(s), provided, however, that the procedures for providing notice are reasonably acceptable to APS. APS shall also provide notice to SDG&E and IID. Unless otherwise agreed by APS and the Interconnection Customer, APS shall provide notice monthly as payments are made in accordance with Article 12.1 and the financial security shall be reduced proportionately on a dollar-for-dollar by the payments made under this Agreement.

SDG&E agrees that within five (5) Calendar Days of receiving notice of a reduction in the amount of the security pursuant to this section, it shall inform the financial institution that holds the Interconnection Financial Security of the reduction in the amount of the security.

- (e) **Increases to Security Required Due to Change of Cost Estimates.** In the event that APS, on behalf of the Transmission Owners, finds that the cost estimate for Transmission Owner Interconnection Facilities and JPP Network Upgrades provided in this Appendix A-1 has increased, APS, on behalf of the Transmission Owners, shall have the option of (1) offsetting any reduction in the amount of security under Section 14(d) of this Appendix A-1 with the increase in the cost estimate, or (2) notifying Interconnection Customer of the required increase in its financial security to conform to the increased cost estimate.
- (f) **Enforcement of Security for Transmission Owners' Interconnection Facilities and JPP Network Upgrades:** In the event that this Agreement is terminated in accordance with Article 2.3 and APS, on behalf of Transmission Owners, is required to determine the cost responsibility of the Interconnection Customer in accordance with Article 2.4 for Transmission Owners' Interconnection Facilities and JPP Network Upgrades set forth in this Appendix A-1, the Parties agree that in addition to following the procedures set forth elsewhere in this Agreement, the Transmission Owners shall proceed as follows:
- (1) Subject to review and approval by all Transmission Owners, APS shall provide a statement indicating the total cost responsibility of the Interconnection Customer to all Transmission Owners and the allocation of this cost responsibility by Ownership Share ("Statement of Cost Responsibility"). This Statement of Cost Responsibility shall be accompanied by a detailed report which shows how the cost responsibility was determined, including information on all expenditures made on behalf of the Interconnection Customer, payments received, and bills outstanding.
 - (2) If the Interconnection Customer has cost responsibility, upon providing the Statement of Cost Responsibility and accompanying information, APS, on behalf of both APS and IID, shall enforce their financial security rights in proportion to the combined Ownership Interests of APS and IID.
 - (3) If the Interconnection Customer has cost responsibility, upon receipt of the Statement of Cost Responsibility and accompanying information, SDG&E shall enforce its financial security rights in proportion to the Ownership Interest of SDG&E. Within thirty Calendar Days of receipt of the Statement of Cost Responsibility, SDG&E shall provide the funds it receives by enforcing its financial security rights to APS.
 - (4) APS, acting on behalf of the Transmission Owners, shall use the funds provided by enforcing the financial security rights of the Transmission Owners to provide reimbursements and settle accounts proportionately in accordance with the Statement of Cost Responsibility and accompanying report.

15. Reporting Requirements:

Until the In-Service Date for the Transmission Owners' Interconnection Facilities and JPP Network Upgrades for Phase A of the Interconnection Project, Interconnection Customer and APS shall conduct a monthly meeting to coordinate the work related to the Transmission Owners' Interconnection Facilities and JPP Network Upgrades in this Appendix A-1. APS shall submit a monthly written report to the Interconnection Customer in advance of the meeting that provides the following information:

- (a) Progress report on activities;
- (b) Project schedule update; and
- (c) Spending report, including actual expenditures to date and forecasted expenditures in accordance with standard accounting practices.

16. Relationship of Agreement to CAISO Phase II Interconnection Study Report

The Parties acknowledge that this Appendix A-1 contains a list of Interconnection Facilities and JPP Network Upgrades and associated cost estimates that differs in some respects from the list of Interconnection Facilities and JPP Network Upgrades and associated cost estimates in the CAISO Phase II Interconnection Study report. The Parties agree to the descriptions of the Interconnection Facilities and JPP Network Upgrades and associated cost estimates in this Agreement notwithstanding any portions of the CAISO Phase II Interconnection Study report that are inconsistent with the terms of this Agreement; provided, however, that any impacts on, and upgrades required to, IID's Affected System (other than the JPP) shall be addressed in the Affected System Study Agreement and Affected System Construction and Operation Agreement to be executed between Interconnection Customer and IID. The Parties also agree that the cost estimates in this Agreement shall serve as the basis for the determination of the amounts of interconnection financial security required pursuant to Article 11.5, including the Interconnection Financial Security required pursuant to Section 9 of the CAISO's LGIP, rather than the cost estimates set forth in the Phase II Interconnection Study report.

Appendix A-2

Interconnection Facilities, JPP Network Upgrades, and Distribution Upgrades for Phase B of the Interconnection Project

The Generating Facility will have a total rated capacity of 500 MW based on both Phase A and Phase B achieving Commercial Operation. Appendix A-1 addresses Phase A of the Generating Facility and this Appendix A-2 addresses Phase B of the Generating Facility. If interconnection studies determined to be necessary pursuant to Section 4 of Appendix C show a need for additional Interconnection Facilities, JPP Network Upgrades, or Distribution Upgrades for Phase B of the Interconnection Project, this Agreement shall be amended in accordance with the provisions of Section 4 of Appendix C.

1. Phase B of the Generating Facility Description:

The Generating Facility consists of a photovoltaic solar field, inverters, a medium voltage collection system, an operations and maintenance building, and various other facilities. Phase B of the Generating Facility will consist of no more than 210 MW (net) of solar photovoltaic units.

The Interconnection Facilities associated with Phase B of the Generating Facility will include additional 34.5kV/500kV transformers and will be connected to the Switchyard via a single 500kV interconnection line separate from the Phase A 500kV interconnection line.

2. Point of Interconnection:

The Point of Interconnection for Phase B of the Generating Facility is the Switchyard. See Appendix C –Diagram.

3. Power Injection Limitation at the Point of Interconnection:

The maximum allowable injection of power into the Switchyard at the Point of Interconnection for Phase B of the Generating Facility shall be 210 MW.

4. Point of Change of Ownership:

The Point of Change of Ownership demarcation point of the high voltage conductors and static wires will be the first designed dead end structure outside of the Switchyard fence. The Point of Change of Ownership will be at the line jumper connection point on the Transmission Owners' dead-ended conductor. Interconnection Customer will provide, per APS specifications, required materials, including foundations, steel structures, insulators, attachment hardware and dead-end connectors to install and terminate conductors at this structure from Switchyard. APS will supply and install conductors to this point of attachment. Interconnection Customer will provide and install materials, including insulators, attachment hardware, conductors, dead-end connectors, and jumper connections, from the Generating Facility substation to the termination point on the dead end structure. See Appendix C – Diagram.

If overhead communication cable is utilized, the interconnection and ownership demarcation point will be a splice point located on the first designed dead-end structure for the high voltage conductor outside of the Switchyard fence. Interconnection Customer will provide required materials for attachment of cable to structures to this point from the Switchyard. APS will provide communication

cable to this point. Interconnection Customer will be responsible for providing materials and connection to APS termination at this location.

If underground communication cable is utilized, the interconnection and ownership demarcation point will be a manhole located outside of the Switchyard fence. APS will provide manhole and other materials required to install cable from the Switchyard. Interconnection Customer will be responsible for providing materials and connection to APS termination at this location.

5. Interconnection Facilities:

(a) Interconnection Customer's Interconnection Facilities.

The Interconnection Customer's Interconnection Facilities consist of additional 34.5/500 kV transformers and a generation tie line from the Generating Facility substation to the Point of Change of Ownership with the Transmission Owner's Interconnection Facilities. The Interconnection Customer's Interconnection Facilities also includes all metering equipment, if any, required for compliance with the CAISO Tariff.

The following is an equipment list from the Interconnection Customer's Interconnection Facilities:

34.5kV/500kV step up transformers
Revenue meter
Shunt capacitors
Transmission structure at ownership change

(b) Transmission Owners' Interconnection Facilities

The Transmission Owners' Interconnection Facilities consist of the facilities between the Point of Change of Ownership and Point of Interconnection in the Switchyard. This consists of one 500 kV disconnect switch, and a span of 500kV conductor. The protection equipment for Phase B of the Interconnection Project is also included in Transmission Owners' Interconnection Facilities as are the metering equipment for the interconnection.

The following is an equipment list from the Transmission Owners' Interconnection Facilities:

Intertie meter
3 500kV, 3000A, Vertical Break Switches
Conductor
Relays

6. JPP Network Upgrades:

APS will design and construct an additional line termination in the new 500kV Switchyard, which will be constructed for Phase A of the Interconnection Project.

The following is an equipment list from the Switchyard portion of the JPP Network Upgrades:

Breakers - 1 500kV, 3000A, 63kA
Switches - 2 500kV, 3000A, Vertical Break

A second breaker will be required when the Switchyard is converted from a ring bus alignment to a breaker and one half arrangement. The timing for this change will be driven by a fifth termination into the Switchyard.

7. Stand-Alone JPP Network Upgrades: None

8. Transmission Owners' Interconnection Facilities and JPP Network Upgrades Cost Summary:

Cost Estimate (2010 dollars)

Element	Cost	Transmission Owner Share		
		APS	IID	SDG&E
Transmission Owners' Interconnection Facilities				
500kV conductor tie line	657,000	0	0	0
Disconnect Switches	150,000	0	0	0
Protection Equipment	375,000	0	0	0
Contingency	236,000	0	0	0
1) Subtotal	1,418,000	0	0	0
JPP Network Upgrades				
Switchyard Breaker	899,000	98,890	114,852	685,218
Deferred breaker	810,000	89,100	103,518	617,382
Contingency	342,000	37,620	43,708	260,672
2) Subtotal	2,051,000	225,610	262,118	1,563,272
3) Total Interconnection Project Cost (for cash flow and financial security) (lines 1 & 2)	3,469,000	381,590	443,338	2,644,072
4) Total Network Upgrades (for reimbursement to North Gila River Development, LLC) (line 2)	2,051,000	225,610	262,118	1,563,272

9. Estimate of Monthly Incurred Costs for the Transmission Owners' Interconnection Facilities and JPP Network Upgrades:

An estimate of the monthly incurred costs is shown below.

Month	Estimated Cost by Month
Oct 2011	26,416
Nov 2011	26,416
Dec 2011	26,416

Jan 2012	609,160
Feb 2012	609,160
Mar 2012	609,160
April 2012	465,980
May 2012	465,980
June 2012	465,980
July 2012	47,180
Aug 2012	47,180
Sept 2012	47,180
Oct 2012	11,396
Nov 2012	11,396
Total	3,469,200

10. Invoicing and JPP Network Upgrade Repayment:

Invoices issued by APS on behalf of the Transmission Owner pursuant to Articles 12.1 and 12.2 of this Agreement for Phase B of the Generating Facility shall include the cumulative balance invoiced to date for the JPP Network Upgrades and the allocation of such balance to the Ownership Interests.

Within thirty (30) Calendar Days of the Commercial Operation Date for a Project Phase, APS, on behalf of the Transmission Owners, shall provide the Parties with a statement which indicates the Ownership Share of each of the Transmission Owners in the cost of the Network Upgrades which are to be repaid in accordance with the provisions of Article 11.4.2 of this Agreement.

- (a) SDG&E Share: Interconnection Customer and SDG&E have agreed that SDG&E shall make the repayment provided for in Article 11.4.2 of this Agreement by making a cash payment to North Gila River Development, LLC within sixty (60) Calendar Days of the Commercial Operation Date of each Project Phase.
- (b) APS Share: APS shall make the repayment provided for in Article 11.4.1 of this Agreement to North Gila River Development, LLC in accordance with the terms of this Agreement.
- (c) IID Share: IID shall make the repayment provided for in Article 11.4.3 of this Agreement to North Gila River Development, LLC in accordance with the terms of this Agreement.

11. Distribution Upgrades: None

12. Maintenance, Repair, and Replacement Charges:

The Interconnection Customer shall be responsible for actual costs incurred by APS, on behalf of the Transmission Owners, applicable to the maintenance, repair and replacement of the Transmission Owners' Interconnection Facilities, including but not limited to: the 500 kV disconnect switches, protection equipment for the Interconnection Customer's Interconnection Facilities, metering including CTs and PTs and communications equipment and all associated equipment (see Appendix C, Diagram). A good faith non-binding estimate of annual cost, for budgetary purposes only, is:

Estimate = \$ 1,000 per year

\$1,000 annually covers:

- Two inspections per year
- Relay maintenance (estimated at every 4-6 years)
- Disconnect switch maintenance (estimated at every 4-6 years)

Additional actual costs will be charged for:

- Emergency maintenance and repair work
- Replacement of failed or failing equipment

13. Provision of Security:

(a) Financial Security to be Posted: The amount available to be drawn under any credit support for the Transmission Owners' Interconnection Facilities and JPP Network Upgrades required to interconnect Phase B of the Generating Facility shall be:

APS Share (11.00%)	\$381,612	
IID Share (12.78%)	\$443,364	
Subtotal of APS and IID Shares (23.78%)		\$824,976
SDG&E Share (76.22%)		\$2,644,224
TOTAL (100%)		\$3,469,200

(b) Posting: The Interconnection Customer shall provide financial security for the Transmission Owners' Interconnection Facilities and JPP Network Upgrades no later than the milestone due date specified in Appendix B-2 in accordance with Article 11.5 of this Agreement. With respect to the financial security for APS and IID shares, Interconnection Customer shall post with APS, as Operating Agent, the amount for both the APS and IID shares specified in Section 13(a) of this Appendix A-2 in the form of one security instrument.

With respect to the Interconnection Financial Security for SDG&E, the amount posted shall be the amount SDG&E is to provide pursuant to Section 13(a) of this Appendix A-2. The Interconnection Financial Security shall be posted in accordance with the terms of the CAISO tariff.

The Parties agree that the Interconnection Customer shall be allowed to make substitutions of the security posted under this Agreement so long as the new security posted is reasonably acceptable to the Transmission Owners, as provided for in Article 11.5 of this Agreement, and in the amount required by this Agreement.

(c) Reduction of Amount of Security: Interconnection Customer shall make arrangements for financial security that provide for periodic reduction of the amount of the financial security upon receipt of instructions from APS, acting on behalf of the Transmission Owners. APS, on behalf of the Transmission Owners, shall provide periodic notices of reductions in the amount of the financial security required to be held to the financial institution(s) the Interconnection Customer selects to hold the financial security. APS shall provide such notices to the financial institution holding the security for the APS and IID shares in accordance with the arrangements made by the Interconnection Customer with the financial institution(s), provided, however, that the procedures for providing notice are reasonably

acceptable to APS. APS shall also provide notice to SDG&E and IID. Unless otherwise agreed by APS and the Interconnection Customer, APS shall provide notice monthly as payments are made in accordance with Article 12.1 and the financial security shall be reduced proportionately on a dollar-for-dollar by the payments made under this Agreement.

SDG&E agrees that within five (5) Calendar Days of receiving notice of a reduction in the amount of the security pursuant to this section, it shall inform the financial institution that holds the Interconnection Financial Security of the reduction in the amount of the security.

- (d) Increases to Security Required Due to Change of Cost Estimates.** In the event that APS, on behalf of the Transmission Owners, finds that the cost estimate for Transmission Owner Interconnection Facilities and Network Upgrades provided in this Appendix A-2 has increased, APS, on behalf of the Transmission Owners, shall have the option of (1) offsetting any reduction in the amount of security under Section 13(c) of this Appendix A-2 with the increase in the cost estimate, or (2) notifying Interconnection Customer of the required increase in its financial security to conform to the increased cost estimate.
- (e) Enforcement of Security for Transmission Owners' Interconnection Facilities and JPP Network Upgrades:** In the event that this Agreement is terminated in accordance with Article 2.3 and APS, on behalf of Transmission Owners, is required to determine the cost responsibility of the Interconnection Customer in accordance with Article 2.4 for Transmission Owners' Interconnection Facilities and JPP Network Upgrades set forth in this Appendix A-2, the Parties agree that in addition to following the procedures set forth elsewhere in the Agreement, the Transmission Owners shall proceed as follows:
- (1)** Subject to review and approval by all Transmission Owners, APS shall provide a statement indicating the total cost responsibility of the Interconnection Customer to all Transmission Owners and the allocation of this cost responsibility by Ownership Share ("Statement of Cost Responsibility"). This Statement of Cost Responsibility shall be accompanied by a detailed report which shows how the cost responsibility was determined, including information on all expenditures made on behalf of the Interconnection Customer, payments received, and bills outstanding.
 - (2)** If the Interconnection Customer has cost responsibility, upon providing the Statement of Cost Responsibility and accompanying information, APS, on behalf of both APS and IID, shall enforce their financial security rights in proportion to the combined Ownership Interests of APS and IID.
 - (3)** If the Interconnection Customer has cost responsibility, upon receipt of the Statement of Cost Responsibility and accompanying information, SDG&E shall enforce its financial security rights in proportion to the Ownership Interest of SDG&E. Within thirty (30) Calendar Days of receipt of the Statement of Cost Responsibility, SDG&E shall provide the funds it receives by enforcing its financial security rights to APS.
 - (4)** APS, acting on behalf of the Transmission Owners, shall use the funds provided by enforcing the financial security rights of the Transmission Owners to provide reimbursements and settle accounts proportionately in accordance with the Statement of Cost Responsibility and accompanying report.

14. Reporting Requirements:

From the date upon which authorization to proceed is provided pursuant to Article 5.1.1 for Phase B of the Generating Facility until the In-Service Date for Phase B of the Interconnection Project, Interconnection Customer and APS shall conduct a monthly meeting to coordinate the work related to

the Transmission Owners' Interconnection Facilities and JPP Network Upgrades in this Appendix A-2. APS shall submit a monthly written report to the Interconnection Customer in advance of the meeting that provides the following information:

- (a) Progress report on activities;
- (b) Project schedule update; and
- (c) Spending report, including actual expenditures to date and forecasted expenditures in accordance with standard accounting practices.

Appendix A-3

SDG&E Network Upgrades for Phase B of the Interconnection Project

If the interconnection studies determined to be necessary pursuant to Section 4 of Appendix C identify additional Network Upgrades to be constructed by SDG&E, the Parties shall amend this Agreement to incorporate provisions for those Network Upgrades into this Appendix A-3.

Appendix B-1

Milestones for Interconnection Facilities and JPP Network Upgrades for Phase A of the Interconnection Project

The Interconnection Customer has selected the Standard Option provided for in Article 5.1. Transmission Owners shall design, procure, and construct Transmission Owner's Interconnection Facilities and JPP Network Upgrades, using Reasonable Efforts to complete Transmission Owner's Interconnection Facilities and JPP Network Upgrades by the dates set forth in this Appendix B-1, Milestones. Milestone dates after October 1, 2010 may be adversely affected by an Effective Date later than October 1, 2010.

Milestones for Interconnection Facilities and JPP Network Upgrades for Phase A of the Interconnection Project	Responsible Party	Due Date
Begin design, permitting and land acquisition for line cut-in facilities	Operating Agent	E&P Agreement
Begin major equipment procurement specifications	Operating Agent	E&P Agreement
Complete planning and equipment specifications	Operating Agent	E&P Agreement
Begin above grade design	Operating Agent	E&P Agreement
Begin below grade design	Operating Agent	E&P Agreement
Submit estimate of Interconnection Customer payments under E&P Agreement and financial security posting requirements	Operating Agent	9/15/2010 or within 5 Calendar Days of Effective Date, if later
Submit interconnection financial security (Sections 5.6.4 and 11.5)	Interconnection Customer	Within 10 Calendar Days of receipt of financial security requirements
Complete transmission line and tower design	Operating Agent	5/31/10
Complete above grade design	Operating Agent	7/30/2010
Additional long lead time material procurement: Breakers, Switches	Operating Agent	Q2 2010
Submit written notice to proceed for procurement of towers	Interconnection Customer	6/1/2010
Complete below grade design	Operating Agent	8/11/10

Submit written authorization to APS to proceed with the construction of the Switchyard portion of Transmission Owners' 500kV Network Upgrades (Section 5.1.1 Standard Option)	Interconnection Customer	10/1/2010 or within 15 Calendar Days of Effective Date, if later
Submit written authorization to APS to proceed with the construction of the transmission line portion of Transmission Owners' 500kV JPP Network Upgrades (section 5.1.1 Standard Option)	Interconnection Customer	11/15/2010 or within 15 Calendar Days of Effective Date, if later
Complete land services/environmental	Operating Agent	12/27/2010
Complete installation of towers and tie line	Operating Agent	3/1/2011
Complete below grade work	Operating Agent	3/1/2011
Complete major equipment procurement	Operating Agent	6/13/2011
Complete material deliveries	Operating Agent	7/11/2011
Complete communications work	Operating Agent	8/22/2011
Complete above grade work	Operating Agent	11/2/2011
Complete control work	Operating Agent	11/3/2011
Line Drop Complete	Operating Agent	11/1/2011
Testing/Commissioning Complete	Operating Agent	12/1/2011
In-Service Date for JPP Network Upgrades and Transmission Owners' Interconnection Facilities	Operating Agent	12/1/2011
In-Service Date for Interconnection Customer's Interconnection Facilities	Interconnection Customer	12/1/2011
Initial Synchronization Date	Interconnection Customer	12/15/2011
Commercial Operation Date (COD) of Phase A of Generating Facility	Interconnection Customer	6/30/2014
Release date of financial security provided for in Appendix A-1 for Phase A of the Interconnection Project	Operating Agent	30 Calendar Days after COD

Early Operations

Given the modular nature of a photovoltaic solar facility, which is constructed in 1-2 MW Project Blocks, various stages of the Generating Facility will be added after Trial Operation of a Project Phase and will commence Commercial Operation prior to the Commercial Operation Date for the Project Phase. From the Initial Synchronization Date for each Project Phase, it is estimated that an additional 8-12 MW will be tested and commence Commercial Operation each month until the entire Project Phase is completed. Following the Initial Synchronization Date, Interconnection Customer will notify APS and CAISO at least ten (10) Calendar Days and not more than thirty (30) Calendar Days prior to the date each portion of the Project Phase with a generation capacity of at least one (1) MW but not more than twenty (20) MW will be completed and commence operation.

Further details regarding early operations will be included in an implementation plan. The proposed implementation plan shall be prepared by the Interconnection Customer and shall be submitted to APS, on behalf of Transmission Owners, and the CAISO for approval at least one-hundred twenty (120) Calendar Days prior to the scheduled In-Service Date for the Transmission Owners' Interconnection Facilities and JPP Network Upgrades for Phase A of the Interconnection Project. CAISO and APS, on behalf of Transmission Owners, shall provide written comments regarding the proposed implementation plan within thirty (30) Calendar Days of receipt. Interconnection Customer, CAISO, and APS shall work in good faith to finalize the implementation plan no later than sixty (60) Calendar Days prior to the scheduled In-Service Date.

Appendix B-2

Milestones for Interconnection Facilities and JPP Network Upgrades for Phase B of the Interconnection Project

The Interconnection Customer has selected the Standard Option provided for in Article 5.1. Transmission Owners shall design, procure, and construct Transmission Owner's Interconnection Facilities and JPP Network Upgrades, using Reasonable Efforts to complete Transmission Owner's Interconnection Facilities and JPP Network Upgrades by the dates set forth in this Appendix B-2, Milestones. Milestone dates after October 1, 2010 may be adversely affected by an Effective Date later than October 1, 2010.

Milestones for Interconnection Facilities and JPP Network Upgrades for Phase B of the Interconnection Project	Responsible Party	Due Date
Submit written notification to Parties of the intended Balancing Authority for Phase B of the Generating Facility	Interconnection Customer	3/15/2011
Complete review of all available studies to determine whether there is a need for additional interconnection studies regarding the possible impacts of Phase B of the Generating Facility on the CAISO Transmission System.	CAISO	4/15/2011
If additional interconnection studies are needed, provide notification to the Parties of the process for having such additional interconnection studies done in accordance with the applicable interconnection process.	CAISO	Note (1)
Complete review of all available studies to determine whether there is a need for additional Affected System Study regarding the possible impacts of Phase B of the Generating Facility on IID's non-JPP facilities.	IID	5/15/ 2011
If additional Affected System Study is needed, provide notification to the Parties of the process for having such additional studies done.	IID	Note (1)
Submit written authorization to proceed with long lead time material procurement and submit procurement financial security	Interconnection Customer	10/1/2011
Begin long lead time material procurement: Breakers, Switches	Operating Agent	1/15/2012
Submit written authorization to APS to proceed with the construction of Phase B of the Interconnection Project and submit construction financial security (Sections 5.6.4 and 11.5)	Interconnection Customer	5/1/2012
In-Service Date for JPP Network Upgrades and Transmission Owners' Interconnection Facilities (conditioned on available outage period)	Operating Agent	10/15/2012
In-Service Date for Interconnection Customer's Interconnection	Interconnection Customer	10/15/2012

Facilities		
Initial Synchronization Date	Interconnection Customer	11/1/2012
Commercial Operation Date (COD) of Phase B of the Generating Facility	Interconnection Customer	6/15/2015
Release date of financial security provided for in Appendix A-2 for Phase B of the Interconnection Project	Operating Agent	30 Calendar Days after COD

Note 1: If additional studies are required pursuant to Section 4 of Appendix C, the Parties will work together to amend this Agreement to modify this Appendix B-2 to establish a new schedule for Phase B of the Interconnection Project that is reasonably acceptable to all Parties.

Early Operations

Given the modular nature of a photovoltaic solar facility, which is constructed in 1-2 MW Project Blocks, various stages of the Generating Facility will be added after Trial Operation of a Project Phase and will commence Commercial Operation prior to the Commercial Operation Date for the Project Phase. From the Initial Synchronization Date for each Project Phase, it is estimated that an additional 8-12 MW will be tested and commence Commercial Operation each month until the entire Project Phase is completed. Following the Initial Synchronization Date, Interconnection Customer will notify APS and CAISO at least ten (10) Calendar Days and not more than thirty (30) Calendar Days prior to the date each portion of the Project Phase with a generation capacity of at least one (1) MW but not more than twenty (20) MW will be completed and commence operation.

Further details regarding early operations will be included in an implementation plan. The proposed implementation plan shall be prepared by the Interconnection Customer and shall be submitted to APS, on behalf of Transmission Owners, and the CAISO for approval at least one hundred twenty (120) Calendar Days prior to the scheduled In-Service Date for the Transmission Owners' Interconnection Facilities and JPP Network Upgrades for Phase B of the Interconnection Project. CAISO and APS, on behalf of Transmission Owners, shall provide written comments regarding the proposed implementation plan within thirty (30) Calendar Days of receipt. Interconnection Customer, CAISO, and APS shall work in good faith to finalize the implementation plan no later than sixty (60) Calendar Days prior to the scheduled In-Service Date.

Appendix B-3

Milestones for SDG&E Network Upgrades for Phase B of the Interconnection Project

If the interconnection studies determined to be necessary pursuant to Section 4 of Appendix C identify additional Network Upgrades to be constructed by SDG&E, the Parties shall amend this Agreement to incorporate milestones for the construction of those Network Upgrades into this Appendix B-3.

Appendix C

Interconnection Details

1. Description of the Large Generating Facility

The Generating Facility consists of a photovoltaic solar field, inverters, a medium voltage collection system, an operations and maintenance building, a 34.5kV/500kV substation and various other facilities. Phase A of the Generating Facility will consist of no more than 290 MW (net) of solar photovoltaic units installed at the site. Phase B of the Generating Facility will consist of no more than 210 MW (net). The Generating Facility will have with a total rated capacity of 500 MW based on both Phase A and Phase B achieving Commercial Operation.

Phase A of the Generating Facility will be interconnected to the Switchyard via a gen-tie line on the diagram below and Phase B of the Generating Facility will be interconnected to the Switchyard via a separate gen-tie line on the diagram.

2. Diagram Illustrating the Facilities at the Switchyard

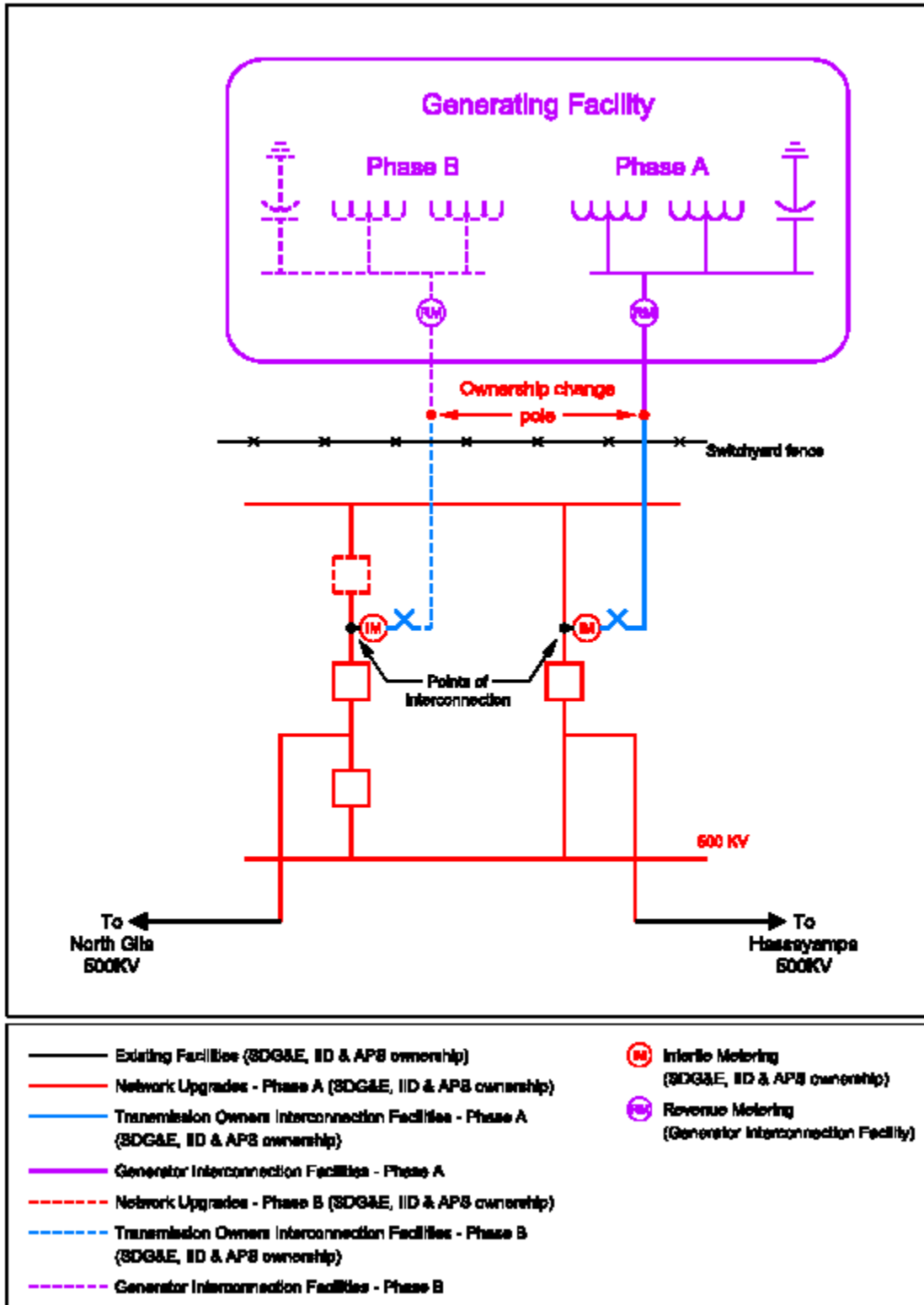

3. Balancing Authority Requirements:

If a Project Phase is to be under a Balancing Authority other than the APS's Balancing Authority, all executed agreements between Interconnection Customer and the other Balancing Authority relating to the Large Generating Facility shall be shared with APS, as the Operating Agent for the JPP.

4. Additional Conditions for Construction of Phase B of the Interconnection Project:

No later than March 15, 2011, Interconnection Customer shall notify the other Parties in writing of the intended Balancing Authority for Phase B of the Generating Facility. Construction of Phase B of the Interconnection Project shall not commence nor shall delivery of energy from Phase B of the Generating Facility to the Transmission System commence until all of the following actions have occurred:

- (a) Interconnection Customer will provide written authorization to APS to proceed with the construction of the Switchyard portion of Transmission Owners' 500kV Network Upgrades for Phase A of the Interconnection Project and Phase A of the Interconnection Project has not otherwise been suspended or terminated.
- (b) Within thirty (30) Calendar Days following receipt of the notice of intended Balancing Authority, the CAISO will review all available studies and determine whether there is a need for additional interconnection studies regarding the possible impacts of Phase B of the Generating Facility on the Transmission System.
- (c) If the CAISO concludes that there is a need for additional interconnection studies, within thirty (30) Calendar Days following receipt of the notice of intended Balancing Authority the CAISO will notify the Parties of the process for having CAISO conduct such additional interconnection studies, which may include the submittal by the Interconnection Customer of an additional Interconnection Request to the CAISO for Phase B of the Generating Facility in accordance with the CAISO's LGIP. Either in accordance with the CAISO's LGIP for a separate Interconnection Request for Phase B of the Generating Facility or pursuant to any other interconnection study process as specified by the CAISO or otherwise determined by FERC for the jurisdictional public utilities which are Parties to this Agreement, the CAISO and Interconnection Customer will enter into an interconnection study agreement under which the Interconnection Customer will agree to pay the reasonable and actual costs of the interconnection studies identified by the CAISO as needed, plus any study deposits required by the CAISO.
- (d) If the CAISO concludes on the basis of the studies provided for in Section 4(c) of this Appendix C that construction of additional facilities is required on the CAISO-controlled grid, this Agreement shall be amended to provide for construction of such facilities and for repayment of the cost of any such facilities that are Network Upgrades in accordance with the principles set forth in Article 11.4.2.
- (e) Within thirty (30) Calendar Days of its receipt of the notice provided by the CAISO in accordance with Section 4(c) of this Appendix C, IID shall determine whether there is a need for an additional Affected System Study regarding the possible impacts of Phase B of the Generating Facility on IID's Transmission System, other than IID's share of the JPP.
- (f) If IID concludes that there is a need for such an additional Affected System Study, IID shall notify the Parties of the process for having IID conduct such an additional Affected System Study and Interconnection Customer shall enter into an Affected System Study Agreement for Phase B of the Generating Facility.
- (g) If IID reasonably concludes on the basis of the studies provided for in Section 4(f) of this Appendix C that construction of additional IID Network Upgrades is required, the

Interconnection Customer and IID shall enter into an Affected System Construction and Operation Agreement for Phase B of the Generating Facility.

5. Joint and Several Liability for Entities Comprising Interconnection Customer

Except as otherwise provided, each entity comprising the Interconnection Customer shall be jointly and severally liable for all obligations required of the Interconnection Customer set forth in this Agreement, including all affirmative covenants and all monetary obligations, the latter of which includes the financing of all Interconnection Facilities and Network Upgrades that are required to be financed by the Interconnection Customer in order to accommodate the interconnection of the entire Generating Facility.

6. Representative of Entities Comprising Interconnection Customer

Agua Caliente Solar LLC and North Gila River Development, LLC shall appoint a single spokesperson, who shall serve as the Interconnection Customer's authorized agent and representative for purposes of administering this Agreement. The designated single spokesperson shall be a single point of contact for CAISO and Transmission Owners and will represent Interconnection Customer for notice purposes and all other communications between and among CAISO, Transmission Owners and Interconnection Customer. Except as otherwise provided, any invoices or refunds due to one of the entities comprising the Interconnection Customer by the Transmission Owners shall be made to the designated single spokesperson. The single spokesperson shall bear all responsibility for disseminating notices, communications and all interactions among the entities comprising the Interconnection Customer, and each entity comprising the Interconnection Customer hereby waives any right to individual notice or communication from CAISO or the Transmission Owners. The CAISO and the Transmission Owners will not be obligated to act on any instructions from either of the entities comprising the Interconnection Customer who is not the designated single spokesperson. The actions of the single spokesperson and his or her representations to CAISO and the Transmission Owners shall be binding upon the Interconnection Customer and each entity comprising the Interconnection Customer. This provision shall be of no further force and effect upon either the division of the Agreement obligations, as set forth in Section 7 of this Appendix C or the termination of Phase B of the Generating Facility, as set forth in Section 8 of this Appendix C.

7. Division of Agreement Obligations.

If the conditions for construction for Phase B of the Interconnection Project set out in Section 4 of this Appendix C have been met, the Interconnection Customer shall determine whether obtaining financing for the Generating Facility on commercially reasonable terms will require separate Large Generator Interconnection Agreements (LGIAs) for Phase A of the Generating Facility and Phase B of the Generating Facility. If the Interconnection Customer determines that separate LGIAs are needed, the Parties agree they shall negotiate in good faith to: (1) amend this Agreement solely for the purpose of making it apply only to Phase A of the Generating Facility and Phase A of the Interconnection Project; and (2) enter into a second LGIA for Phase B of the Generating Facility on terms that are substantially similar in all material relevant respects to this Agreement and to the amended version of this Agreement for Phase A of the Generating Facility. In such event, the joint and several liability set out in Section 5 of this Appendix C shall cease.

8. Termination of Phase B of the Generating Facility.

In addition to the termination right provided in Article 2.3 of this Agreement, and subject to its terms, those of Article 2.4 of the Agreement and any applicable Tariff, North Gila River Development, LLC may terminate this Agreement as it relates to Phase B of the Generating Facility provided the right to

terminate Phase B of the Generating Facility is conditioned on an obligation to fund the Network Upgrades set forth in Appendix A-2 in the event such termination constitutes a Material Modification of the Interconnection Request and is necessary to avoid adversely impacting lower queued interconnection customers. In the event North Gila River Development, LLC elects to terminate this Agreement as it relates to Phase B of the Generating Facility, this Agreement shall be amended accordingly so as to remove all references, terms and conditions pertaining to Phase B of the Generating Facility. Such termination shall leave unaffected the terms and conditions in this Agreement with respect to Phase A of the Generating Facility.

Appendix D

Security Arrangements Details

Infrastructure security of Transmission System equipment and operations and control hardware and software is essential to ensure day-to-day Transmission System reliability and operational security. FERC will expect all transmission providers, market participants, and Interconnection Customers interconnected to the Transmission System to comply with the recommendations offered by the President's Critical Infrastructure Protection Board and, eventually, best practice recommendations from the electric reliability authority. All public utilities will be expected to meet basic standards for system infrastructure and operational security, including physical, operational, and cyber-security practices.

If the Interconnection Customer selects the CAISO as the Balancing Authority for a Project Phase, for that Project Phase the Interconnection Customer shall meet the requirements for security implemented pursuant to the CAISO Tariff, including the CAISO's standards for information security posted on the CAISO's internet web site at the following internet address: <http://www.aiso.com/pubinfo/info-security/index.html>.

Appendix E

Commercial Operation Date

This Appendix E is a part of the Agreement.

[Date]

**Arizona Public Service Co.
Attn: Manager of Interconnection Development
MS 2259
P.O. Box 53999
Phoenix, AZ 85072-3999**

Mr. Stephen Rutt
Manager of Grid Assets
California Independent System Operator Corporation
151 Blue Ravine Road
Folsom, CA 95630

Mr. Robert Kott
Manager of Model & Contract Implementation
California Independent System Operator Corporation
151 Blue Ravine Road
Folsom, CA 95630

Re: Commercial Operation Date of Phase ___ of the Generating Facility

Dear _____:

On **[Date]** **[Interconnection Customer]** completed the last Project Block of Phase ___ of the Generating Facility. This letter confirms that the Commercial Operation Date of Phase ___ of the Generating Facility, is **[Date plus one day]** and that **[Entity Comprising Interconnection Customer]** provided the CAISO's operations personnel advance notice of this intended Commercial Operation Date no less than five Business Days prior to that date.

Thank you.

[Signature]

[Interconnection Customer Representative]

Appendix F

Addresses for Delivery of Notices and Billings

Notices:

Operating Agent:

Arizona Public Service Company
Attn: Manager of Interconnection Development
MS 2259
P.O. Box 53999
Phoenix, AZ 85072-3999

Transmission Owners:

Arizona Public Service Company
Attn: Manager of Interconnection Development
MS 2259
P.O. Box 53999
Phoenix, AZ 85072-3999

Imperial Irrigation District
Attention: Inter-Connect Transmission Contract Administrator
333 East Barioni Boulevard
PO Box 937
Imperial, CA 92251

San Diego Gas & Electric Company
Attn: Transmission Planning Manager
8316 Century Park Court; CP52A
San Diego, CA 92123-1593

California Independent System Operator Corporation

California ISO
Ms. Judy Brown
151 Blue Ravine Rd.
Folsom, CA 95630

Designated Single Spokesperson for Entities Comprising Interconnection Customer:

Agua Caliente Solar, LLC (Phase A) and North Gila River Development, LLC (Phase B)
Attn: : Jim Filippi, Director of Transmission
353 Sacramento St.
Suite 2100
San Francisco, CA 94111

With a copy to:
NextLight Renewable Power, LLC
Attn: Robert F. Miller, Vice President & General Counsel

353 Sacramento St.
Suite 2100
San Francisco, CA 94111

Billings and Payments:

Operating Agent:

Arizona Public Service Company
Attn: Manager of Interconnection Development
MS 2259
P.O. Box 53999
Phoenix, AZ 85072-3999

Interconnection Customer:

Agua Caliente Solar, LLC (Phase A) and North Gila River Development, LLC (Phase B)
Attn: Controller
353 Sacramento St.
Suite 2100
San Francisco, CA 94111

With a copy to:
NextLight Renewable Power, LLC
Attn: Jim Filippi, Director of Transmission
353 Sacramento St.
Suite 2100
San Francisco, CA 94111

California Independent System Operator Corporation

California ISO
Finance Dept.
Dennis Estrada
151 Blue Ravine Rd.
Folsom, CA 95630

Alternative Forms of Delivery of Notices (telephone, facsimile or email):

Transmission Owners:

Arizona Public Service Company
Attn: Manager, Interconnections Development
MS 2259
P.O. Box 53999
Phoenix, AZ 85072-3999

502 South 2nd Avenue, MS 2259
Phoenix, AZ 85003

Phone: (602) 250-1644
Facsimile: (602) 250-1674
Email: Rex.Stulting@aps.com

Imperial Irrigation District
Attention: Inter-Connect Transmission Contract Administrator
333 East Barioni Boulevard
PO Box 937
Imperial, CA 92251

San Diego Gas & Electric Company
Grid Operations Services Manager
Phone: 619-725-8637
Fax: 619-683-3291

California Independent System Operator Corporation
jbrown@caiso.com

Designated Single Spokesperson for Entities Comprising Interconnection Customer:

Agua Caliente Solar, LLC (Phase A) and North Gila River Development, LLC (Phase B)
Attn: Jim Filippi
353 Sacramento St.
Suite 2100
San Francisco, CA 94111

Phone: (415) 935-2498
Facsimile: (415) 935-2499
Email: jfilippi@nextlight.com

With a copy to:
NextLight Renewable Power, LLC
Attn: Robert F. Miller, Vice President & General Counsel
353 Sacramento St.
Suite 2100
San Francisco, CA 94111

Phone: (415) 935-2500
Facsimile: (415) 935-2501

For Billings:
Agua Caliente Solar, LLC (Phase A) and North Gila River Development, LLC (Phase B)
Attn: Controller
353 Sacramento St.
Suite 2100
San Francisco, CA 94111

Facsimile: (415) 935-2501
Email: ap@nextlight.com

Interconnection Customer Contact Information Regarding General Operating Issues

(Non Real-Time)

Interconnection Customer shall provide Contact information within 120 days of the expected energization of the Switchyard as part of the implementation plan.

Interconnection Customer Contact Information Regarding Real-Time Operating Issues

(Real-Time 24/7)

Interconnection Customer shall provide Contact information within 120 days of the expected energization of the Switchyard as part of the implementation plan.

Operating Agent Contact Information Regarding General Operating Issues

(Non Real-Time)

Arizona Public Service Company
Attn: Thomas Glock, Power Operations Manager
MS 2260
P.O. Box 53999
Phoenix, AZ 85072-3999

502 South 2nd Avenue, MS 2260
Phoenix, AZ 85003

Phone: APS shall provide within 120 days of the expected energization of the Switchyard
Facsimile: APS shall provide within 120 days of the expected energization of the Switchyard
Email: Thomas.Glock@aps.com

Operating Agent Contact Information Regarding Real-Time Operating Issues

(Real-Time 24/7)

APS Energy Control Center
ECC Supervisor

Transmission Issues

Phone: APS shall provide within 120 days of the expected energization of the Switchyard

Generation Issues

Phone: APS shall provide within 120 days of the expected energization of the Switchyard

Appendix G

Requirements of a Wind Generating Plant

Intentionally Omitted as Inapplicable

Appendix H

Reliability Management System Agreement

RELIABILITY MANAGEMENT SYSTEM AGREEMENT
by and between
[TRANSMISSION OPERATOR]
and
[GENERATOR]

THIS RELIABILITY MANAGEMENT SYSTEM AGREEMENT(the "Agreement"), is entered into this ____ day of _____, _____, by and between _____ (the "Transmission Operator") and _____ (the "Generator").

WHEREAS, there is a need to maintain the reliability of the interconnected electric systems encompassed by the WECC in a restructured and competitive electric utility industry;

WHEREAS, with the transition of the electric industry to a more competitive structure, it is desirable to have a uniform set of electric system operating rules within the Western Interconnection, applicable in a fair, comparable and non-discriminatory manner, with which all market participants comply; and

WHEREAS, the members of the WECC, including the Transmission Operator, have determined that a contractual Reliability Management System provides a reasonable, currently available means of maintaining such reliability.

NOW, THEREFORE, in consideration of the mutual agreements contained herein, and other good and valuable consideration, the receipt and sufficiency of which is hereby acknowledged, the Transmission Operator and the Generator agree as follows:

1. PURPOSE OF AGREEMENT

The purpose of this Agreement is to maintain the reliable operation of the Western Interconnection through the Generator's commitment to comply with certain reliability standards.

2. DEFINITIONS

In addition to terms defined in the beginning of this Agreement and in the Recitals hereto, for purposes of this Agreement the following terms shall have the meanings set forth beside them below.

Control Area means an electric system or systems, bounded by interconnection metering and telemetry, capable of controlling generation to maintain its interchange schedule with other Control Areas and contributing to frequency regulation of the Western Interconnection.

FERC means the Federal Energy Regulatory Commission or a successor agency.

Member means any party to the WECC Agreement.

Party means either the Generator or the Transmission Operator and **Parties** means both of the Generator and the Transmission Operator.

Reliability Management System or RMS means the contractual reliability management program implemented through the WECC Reliability Criteria Agreement, the WECC RMS Agreement, this Agreement, and any similar contractual arrangement.

Western Interconnection means the area comprising those states and provinces, or portions thereof, in Western Canada, Northern Mexico and the Western United States in which Members of the WECC operate synchronously connected transmission systems.

Working Day means Monday through Friday except for recognized legal holidays in the state in which any notice is received pursuant to Section 8.

WECC means the Western Electricity Coordinating Council or a successor entity.

WECC Agreement means the Western Electricity Coordinating Council Agreement dated March 20, 1967, as such may be amended from time to time.

WECC Reliability Criteria Agreement means the Western Electricity Coordinating Council Reliability Criteria Agreement dated _____, _____ among the WECC and certain of its member transmission operators, as such may be amended from time to time.

WECC RMS Agreement means an agreement between the WECC and the Transmission Operator requiring the Transmission Operator to comply with the reliability criteria contained in the WECC Reliability Criteria Agreement.

WECC Staff means those employees of the WECC, including personnel hired by the WECC on a contract basis, designated as responsible for the administration of the RMS.

3. TERM AND TERMINATION

3.1 Term. This Agreement shall become effective [thirty (30) days after the date of issuance of a final FERC order accepting this Agreement for filing without requiring any changes to this Agreement unacceptable to either Party. Required changes to this Agreement shall be deemed unacceptable to a Party only if that Party provides notice to the other Party within fifteen (15) days of issuance of the applicable FERC order that such order is unacceptable]. [Note: if the interconnection agreement is not FERC jurisdictional, replace bracketed language with: [on the later of: (a) the date of execution; or (b) the effective date of the WECC RMS Agreement.]

3.2 Notice of Termination of WECC RMS Agreement. The Transmission Operator shall give the Generator notice of any notice of termination of the WECC RMS Agreement by the WECC or by the Transmission Operator within fifteen (15) days of receipt by the WECC or the Transmission Operator of such notice of termination.

3.3 Termination by the Generator. The Generator may terminate this Agreement as follows:

(a) following the termination of the WECC RMS Agreement for any reason by the WECC or by the Transmission Operator, provided such notice is provided within forty-five (45) days of the termination of the WECC RMS Agreement;

(b) following the effective date of an amendment to the requirements of the WECC Reliability Criteria Agreement that adversely affects the Generator, provided notice of such termination is given within forty-five (45) days of the date of issuance of a FERC order accepting such amendment for filing, provided further that the forty-five (45) day period within which notice of termination is required may be extended by the Generator for an additional forty-five (45) days if the Generator gives written notice to the Transmission Operator of such requested extension within the initial forty-five (45) day period; or

(c) on one year's written notice to the Transmission Operator and the WECC, following any change in the WECC Reliability Criteria Agreement that materially affects Generator's obligations.

3.4 Termination by the Transmission Operator. The Transmission Operator may terminate this Agreement on thirty (30) days' written notice following the termination of the WECC RMS Agreement for any reason by the WECC or by the Transmission Operator, provided such notice is provided within thirty (30) days of the termination of the WECC RMS Agreement.

3.5 Mutual Agreement. This Agreement may be terminated at any time by the mutual agreement of the Transmission Operator and the Generator.

4. COMPLIANCE WITH AND AMENDMENT OF WECC RELIABILITY CRITERIA

4.1 Compliance with Reliability Criteria. The Generator agrees to comply with the requirements of the WECC Reliability Criteria Agreement, including the applicable WECC reliability criteria contained in Section IV of Annex A thereof, and, in the event of failure to comply, agrees to be subject to the sanctions applicable to such failure. Each and all of the provisions of the WECC Reliability Criteria Agreement are hereby incorporated by reference into this Agreement as though set forth fully herein, and the Generator shall for all purposes be considered a Participant, and shall be entitled to all of the rights and privileges and be subject to all of the obligations of a Participant, under and in connection with the WECC Reliability Criteria Agreement, including but not limited to the rights, privileges and obligations set forth in Sections 5, 6 and 10 of the WECC Reliability Criteria Agreement.

4.2 Modifications to WECC Reliability Criteria Agreement. The Transmission Operator shall notify the Generator within fifteen (15) days of the receipt of notice from the WECC of the initiation of any WECC process to modify the WECC Reliability Criteria Agreement. The WECC RMS Agreement specifies that such process shall comply with the procedures, rules, and regulations then applicable to the WECC for modifications to reliability criteria.

4.3 Notice of Modifications to WECC Reliability Criteria Agreement. If, following the process specified in Section 4.2, any modification to the WECC Reliability Criteria Agreement is to take effect, the Transmission Operator shall provide notice to the Generator at least forty-five (45) days before such modification is scheduled to take effect.

4.4 Effective Date. Any modification to the WECC Reliability Criteria Agreement shall take effect on the date specified by FERC in an order accepting such modification for filing.

4.5 Transfer of Control or Sale of Generation Facilities. In any sale or transfer of control of any generation facilities subject to this Agreement, the Generator shall as a condition of such sale or transfer require the acquiring party or transferee with respect to the transferred facilities either to assume the obligations of the Generator with respect to this Agreement or to enter into an agreement with the Control Area Operator in substantially the form of this Agreement.

5. SANCTIONS

5.1 Payment of Monetary Sanctions. The Generator shall be responsible for payment directly to the WECC of any monetary sanction assessed against the Generator pursuant to this Agreement and the WECC Reliability Criteria Agreement. Any such payment shall be made pursuant to the procedures specified in the WECC Reliability Criteria Agreement.

5.2 Publication. The Generator consents to the release by the WECC of information related to the Generator's compliance with this Agreement only in accordance with the WECC Reliability Criteria Agreement.

5.3 Reserved Rights. Nothing in the RMS or the WECC Reliability Criteria Agreement shall affect the right of the Transmission Operator, subject to any necessary regulatory approval, to take such other measures to maintain reliability, including disconnection, which the Transmission Operator may otherwise be entitled to take. Either Party shall have the right to make a unilateral filing with FERC to modify this Agreement with respect to any provision hereof under section 205, section 206, or any other applicable provision of the Federal Power Act and FERC's rules and regulations thereunder; provided that each Party shall have the right to protest any such filing by the other Party and to participate fully in any proceeding before FERC in which such modifications may be considered.

6. THIRD PARTIES

Except for the rights and obligations between the WECC and Generator specified in Sections 4 and 5, this Agreement creates contractual rights and obligations solely between the Parties. Nothing in this Agreement shall create, as between the Parties or with respect to the WECC: (1) any obligation or liability whatsoever (other than as expressly provided in this Agreement), or (2) any duty or standard of care whatsoever. In addition, nothing in this Agreement shall create any duty, liability, or standard of care whatsoever as to any other party. Except for the rights, as a third-party beneficiary with respect to Sections 4 and 5, of the WECC against Generator, no third party shall have any rights whatsoever with respect to enforcement of any provision of this Agreement. Transmission Operator and Generator expressly intend that the WECC is a third-party beneficiary to this Agreement, and the WECC shall have the right to seek to enforce against Generator any provisions of Sections 4 and 5, provided that specific performance shall be the sole remedy available to the WECC pursuant to this Agreement, and Generator shall not be liable to the WECC pursuant to this Agreement for damages of any kind whatsoever (other than the payment of sanctions to the WECC, if so construed), whether direct, compensatory, special, indirect, consequential, or punitive.

7. REGULATORY APPROVALS

This Agreement shall be filed with FERC by the Transmission Operator under Section 205 of the Federal Power Act. In such filing, the Transmission Operator shall request that FERC accept this Agreement for filing without modification to become effective on the day after the date of a FERC order accepting this Agreement for filing.

8. NOTICES

Any notice, demand or request required or authorized by this Agreement to be given in writing to a Party shall be delivered by hand, courier or overnight delivery service, mailed by certified mail (return receipt requested) postage prepaid, faxed, or delivered by mutually agreed electronic means to such Party at the following address:

_____:

Fax: _____

_____ : _____

Fax: _____

The designation of such person and/or address may be changed at any time by either Party upon receipt by the other of written notice. Such a notice served by mail shall be effective upon receipt. Notice transmitted by facsimile shall be effective upon receipt if received prior to 5:00 p.m. on a Working Day, and if not received prior to 5:00 p.m. on a Working Day, receipt shall be effective on the next Working Day.

9. APPLICABILITY

This Agreement (including all appendices hereto and, by reference, the WECC Reliability Criteria Agreement) constitutes the entire understanding between the Parties hereto with respect to the subject matter hereof, supersedes any and all previous understandings between the Parties with respect to the subject matter hereof, and binds and inures to the benefit of the Parties and their successors.

10. AMENDMENT

No amendment of all or any part of this Agreement shall be valid unless it is reduced to writing and signed by both Parties hereto. The terms and conditions herein specified shall remain in effect throughout the term and shall not be subject to change through application to the FERC or other governmental body or authority, absent the agreement of the Parties.

11. INTERPRETATION

Interpretation and performance of this Agreement shall be in accordance with, and shall be controlled by, the laws of the State of _____ but without giving effect to the provisions thereof relating to conflicts of law. Article and section headings are for convenience only and shall not affect the interpretation of this Agreement. References to articles, sections and appendices are, unless the context otherwise requires, references to articles, sections and appendices of this Agreement.

12. PROHIBITION ON ASSIGNMENT

This Agreement may not be assigned by either Party without the consent of the other Party, which consent shall not be unreasonably withheld; provided that the Generator may without the consent of the WECC or Transmission Operator assign this Agreement (a) as collateral security to aid in providing financing or refinancing for the construction, ownership or operation of the Generator's power generating facility, or (b) to any acquiring party or transferee referenced in Section 4.5 of this Agreement. If requested by Generator, Transmission Operator will enter into a consent on commercially reasonable terms to any assignment of this Agreement by Generator under this Section 12.

13. SEVERABILITY

If one or more provisions herein shall be invalid, illegal or unenforceable in any respect, it shall be given effect to the extent permitted by applicable law, and such invalidity, illegality or unenforceability shall not affect the validity of the other provisions of this Agreement.

14. COUNTERPARTS

This Agreement may be executed in counterparts and each shall have the same force and effect as an original.

IN WITNESS WHEREOF, the Transmission Operator and the Generator have each caused this Reliability Management System Agreement to be executed by their respective duly authorized officers as of the date first above written.

By: _____
Name:
Title:

By: _____
Name:
Title:

ATTACHMENT B-3

Service Agreement No. 1566

under

**California Independent System Operator Corporation
FERC Electric Tariff, Fourth Replacement Volume No. II**

LARGE GENERATOR INTERCONNECTION AGREEMENT (LGIA)
BY AND BETWEEN
AGUA CALIENTE SOLAR, LLC,
NORTH GILA RIVER DEVELOPMENT, LLC,
ARIZONA PUBLIC SERVICE COMPANY,
IMPERIAL IRRIGATION DISTRICT,
SAN DIEGO GAS & ELECTRIC COMPANY, AND
CALIFORNIA INDEPENDENT SYSTEM OPERATOR CORPORATION

TABLE OF CONTENTS

	Page
RECITALS	1
ARTICLE 1 DEFINITIONS	3
ARTICLE 2 EFFECTIVE DATE, TERM, AND TERMINATION	11
2.1 EFFECTIVE DATE.	11
2.2 TERM OF AGREEMENT	12
2.3 TERMINATION PROCEDURES	12
2.3.1 WRITTEN NOTICE	12
2.3.2 DEFAULT	12
2.4 TERMINATION COSTS.....	12
2.5 DISCONNECTION	14
2.6 SURVIVAL	14
ARTICLE 3. REGULATORY FILINGS	14
3.1 FILING.....	15
ARTICLE 4. SCOPE OF SERVICE.....	15
4.1 INTERCONNECTION PRODUCT OPTIONS.....	15
4.1.1 CAISO INTERCONNECTION SERVICE	15
4.1.2 ENERGY RESOURCE INTERCONNECTION SERVICE.....	15
4.1.2.1 THE PRODUCT	15
4.1.2.2 TRANSMISSION DELIVERY SERVICE IMPLICATIONS.....	15
4.1.3 NETWORK RESOURCE INTERCONNECTION SERVICE.....	16
4.1.3.1 THE PRODUCT	16
4.1.3.2 TRANSMISSION DELIVERY SERVICE IMPLICATIONS.....	16
4.2 PROVISION OF SERVICE	16
4.3 PERFORMANCE STANDARDS	16
4.4 NO TRANSMISSION DELIVERY SERVICE	16
4.5 INTERCONNECTION CUSTOMER PROVIDED SERVICES	16
ARTICLE 5. INTERCONNECTION FACILITIES ENGINEERING, PROCUREMENT, AND CONSTRUCTION	16
5.1 OPTIONS.....	17
5.1.1 STANDARD OPTION.....	17

5.1.2	ALTERNATE OPTION	17
5.1.3	OPTION TO BUILD	17
5.1.4	NEGOTIATED OPTION.....	17
5.2	GENERAL CONDITIONS APPLICABLE TO OPTION TO BUILD.....	17
5.3	LIQUIDATED DAMAGES.....	17
5.4	POWER SYSTEM STABILIZERS	17
5.5	EQUIPMENT PROCUREMENT.....	18
5.6	CONSTRUCTION COMMENCEMENT.....	18
5.7	WORK PROGRESS.....	18
5.8	INFORMATION EXCHANGE	19
5.9	LIMITED OPERATION.....	19
5.10	INTERCONNECTION CUSTOMER’S INTERCONNECTION FACILITIES (‘ICIF’).....	19
5.10.1	INTERCONNECTION CUSTOMER’S INTERCONNECTION FACILITY SPECIFICATIONS	19
5.10.2	REVIEW BY TRANSMISSION OWNERS AND CAISO.....	19
5.10.3	ICIF CONSTRUCTION	20
5.11	TRANSMISSION OWNERS’ INTERCONNECTION FACILITIES CONSTRUCTION.....	20
5.12	ACCESS RIGHTS	20
5.13	LANDS OF OTHER PROPERTY OWNERS	21
5.14	PERMITS.....	21
5.15	EARLY CONSTRUCTION OF BASE CASE FACILITIES.....	21
5.16	SUSPENSION.....	21
5.17	TAXES.....	22
5.17.1	INTERCONNECTION CUSTOMER PAYMENTS NOT TAXABLE	22
5.17.2	REPRESENTATIONS AND COVENANTS	22
5.17.3	INDEMNIFICATION FOR THE COST CONSEQUENCES OF CURRENT TAX LIABILITY IMPOSED UPON THE TRANSMISSION OWNER.....	23
5.17.4	TAX GROSS-UP AMOUNT.....	23
5.17.5	PRIVATE LETTER RULING OR CHANGE OR CLARIFICATION OF LAW	24
5.17.6	SUBSEQUENT TAXABLE EVENTS	24
5.17.7	CONTESTS.....	24
5.17.8	REFUND	25

5.17.9	TAXES OTHER THAN INCOME TAXES.....	26
5.18	TAX STATUS	27
5.19	MODIFICATION.....	27
5.19.1	GENERAL	27
5.19.2	STANDARDS	28
5.19.3	MODIFICATION COSTS	28
ARTICLE 6.	TESTING AND INSPECTION.....	28
6.1	PRE-COMMERCIAL OPERATION DATE TESTING AND MODIFICATIONS	28
6.2	POST-COMMERCIAL OPERATION DATE TESTING AND MODIFICATIONS	29
6.3	RIGHT TO OBSERVE TESTING.....	29
6.4	RIGHT TO INSPECT	29
ARTICLE 7.	METERING	29
7.1	GENERAL	29
7.2	CHECK METERS	30
7.3	STANDARDS	30
7.4	TESTING OF METERING EQUIPMENT	30
7.5	METERING DATA	30
7.6	METERING REQUIREMENTS OF CAISO.....	30
ARTICLE 8.	COMMUNICATIONS.....	31
8.1	INTERCONNECTION CUSTOMER OBLIGATIONS	31
8.2	REMOTE TERMINAL UNIT	31
8.3	NO ANNEXATION	32
8.4	COMMUNICATION REQUIREMENTS OF CAISO.....	32
ARTICLE 9.	OPERATIONS	32
9.1	GENERAL	32
9.2	BALANCING AUTHORITY AREA NOTIFICATION.....	32
9.3	TRANSMISSION OWNER AND CAISO OBLIGATIONS	32
9.4	INTERCONNECTION CUSTOMER OBLIGATIONS	32
9.5	START-UP AND SYNCHRONIZATION.....	33
9.6	REACTIVE POWER	33
9.6.1	POWER FACTOR DESIGN CRITERIA	33
9.6.2	VOLTAGE SCHEDULES	33

9.6.2.1	GOVERNORS AND REGULATORS.....	34
9.6.3	PAYMENT FOR REACTIVE POWER.....	34
9.7	OUTAGES AND INTERRUPTIONS.....	34
9.7.1	OUTAGES	34
9.7.1.1	OUTAGE AUTHORITY AND COORDINATION.....	34
9.7.1.2	OUTAGE SCHEDULES	35
9.7.1.3	OUTAGE RESTORATION.....	35
9.7.2	INTERRUPTION OF SERVICE.....	36
9.7.3	UNDER-FREQUENCY AND OVER FREQUENCY CONDITIONS.....	37
9.7.4	SYSTEM PROTECTION AND OTHER CONTROL REQUIREMENTS.....	37
9.7.4.1	SYSTEM PROTECTION FACILITIES	37
9.7.5	REQUIREMENTS FOR PROTECTION.....	38
9.7.6	POWER QUALITY.....	38
9.8	SWITCHING AND TAGGING RULES.....	38
9.9	USE OF INTERCONNECTION FACILITIES BY THIRD PARTIES.....	38
9.9.1	PURPOSE OF INTERCONNECTION FACILITIES	39
9.9.2	THIRD PARTY USERS	39
9.10	DISTURBANCE ANALYSIS DATA EXCHANGE.....	39
ARTICLE 10.	MAINTENANCE.....	39
10.1	TRANSMISSION OWNER OBLIGATIONS.....	39
10.2	INTERCONNECTION CUSTOMER OBLIGATIONS	39
10.3	COORDINATION.....	39
10.4	SECONDARY SYSTEMS	40
10.5	OPERATING AND MAINTENANCE EXPENSES.....	40
ARTICLE 11.	PERFORMANCE OBLIGATION.....	40
11.1	INTERCONNECTION CUSTOMER INTERCONNECTION FACILITIES.....	40
11.2	TRANSMISSION OWNERS' INTERCONNECTION FACILITIES	40
11.3	NETWORK UPGRADES AND DISTRIBUTION UPGRADES.....	40
11.4	TRANSMISSION CREDITS	40
11.4.1	REPAYMENT OF AMOUNTS ADVANCED TO APS FOR NETWORK UPGRADES TO APS'S SHARE OF THE JPP.....	40

11.4.2	REPAYMENT OF AMOUNTS ADVANCED TO SDG&E FOR NETWORK UPGRADES TO ITS SHARE OF THE JPP AND TO ITS NON-JPP FACILITIES	41
11.4.3	REPAYMENT OF AMOUNTS ADVANCED TO IID FOR NETWORK UPGRADES TO IID’S SHARE OF THE JPP.....	42
11.4.4	SPECIAL PROVISIONS FOR AFFECTED SYSTEMS	43
11.5	PROVISION OF SECURITY.....	44
11.6	INTERCONNECTION CUSTOMER COMPENSATION.....	46
11.6.1	INTERCONNECTION CUSTOMER COMPENSATION FOR ACTIONS DURING EMERGENCY CONDITION.....	46
ARTICLE 12.	INVOICE	46
12.1	GENERAL PROVISIONS	46
12.2	FINAL INVOICE.....	47
12.3	PAYMENT.....	47
12.4	DISPUTES	47
ARTICLE 13.	EMERGENCIES	48
13.1	DEFINITION	48
13.2	OBLIGATIONS.....	48
13.3	NOTICE	48
13.4	IMMEDIATE ACTION.....	48
13.5	TRANSMISSION OWNER AND CAISO AUTHORITY	49
13.5.1	GENERAL	49
13.5.2	REDUCTION AND DISCONNECTION.....	49
13.6	INTERCONNECTION CUSTOMER AUTHORITY	50
13.7	LIMITED LIABILITY	50
ARTICLE 14.	REGULATORY REQUIREMENTS AND GOVERNING LAW	50
14.1	REGULATORY REQUIREMENTS.....	50
14.2	GOVERNING LAW.....	50
ARTICLE 15.	NOTICES.....	50
15.1	GENERAL	50
15.2	BILLINGS AND PAYMENTS.....	51
15.3	ALTERNATIVE FORMS OF NOTICE	51
15.4	OPERATIONS AND MAINTENANCE NOTICE.....	51

ARTICLE 16.	FORCE MAJEURE.....	51
ARTICLE 17.	DEFAULT	51
17.1	DEFAULT	51
17.1.1	GENERAL	51
17.1.2	RIGHT TO TERMINATE.....	52
ARTICLE 18.	INDEMNITY, CONSEQUENTIAL DAMAGES AND INSURANCE.....	52
18.1	INDEMNITY	52
18.1.1	INDEMNIFIED PARTY	52
18.1.2	INDEMNIFYING PARTY	52
18.1.3	INDEMNITY PROCEDURES	52
18.2	CONSEQUENTIAL DAMAGES.....	53
18.3	INSURANCE	53
ARTICLE 19.	ASSIGNMENT	55
ARTICLE 20.	SEVERABILITY	55
ARTICLE 21.	COMPARABILITY	56
ARTICLE 22.	CONFIDENTIALITY	56
22.1	CONFIDENTIALITY	56
22.1.1	TERM	56
22.1.2	SCOPE	56
22.1.3	RELEASE OF CONFIDENTIAL INFORMATION	57
22.1.4	RIGHTS.....	57
22.1.5	NO WARRANTIES	57
22.1.6	STANDARD OF CARE	57
22.1.7	DISCLOSURE REQUIRED BY LAW OR ORDER	57
22.1.8	TERMINATION OF AGREEMENT	58
22.1.9	REMEDIES	58
22.1.10	DISCLOSURE TO FERC, ITS STAFF, OR A STATE.....	58
ARTICLE 23.	ENVIRONMENTAL RELEASES.....	59
ARTICLE 24.	INFORMATION REQUIREMENTS	59
24.1	INFORMATION ACQUISITION	59
24.2	INFORMATION SUBMISSION BY APS, ON BEHALF OF TRANSMISSION OWNERS.....	59
24.3	UPDATED INFORMATION SUBMISSION BY INTERCONNECTION CUSTOMER.....	59

24.4	INFORMATION SUPPLEMENTATION.....	60
ARTICLE 25.	INFORMATION ACCESS AND AUDIT RIGHTS	61
25.1	INFORMATION ACCESS.....	61
25.2	REPORTING OF NON-FORCE MAJEURE EVENTS.....	61
25.3	AUDIT RIGHTS	61
25.4	AUDIT RIGHTS PERIODS	61
	25.4.1 AUDIT RIGHTS PERIOD FOR CONSTRUCTION-RELATED ACCOUNTS AND RECORDS.....	62
	25.4.2 AUDIT RIGHTS PERIOD FOR ALL OTHER ACCOUNTS AND RECORDS	62
25.5	AUDIT RESULTS	62
ARTICLE 26.	SUBCONTRACTORS.....	62
26.1	GENERAL	62
26.2	RESPONSIBILITY OF PRINCIPAL	62
26.3	NO LIMITATION BY INSURANCE	62
ARTICLE 27.	DISPUTES	62
27.1	SUBMISSION.....	63
27.2	EXTERNAL ARBITRATION PROCEDURES.....	63
27.3	ARBITRATION DECISIONS.....	63
27.4	COSTS	63
ARTICLE 28.	REPRESENTATIONS, WARRANTIES, AND COVENANTS	63
28.1	GENERAL	64
	28.1.1 GOOD STANDING	64
	28.1.2 AUTHORITY	64
	28.1.3 NO CONFLICT	64
	28.1.4 CONSENT AND APPROVAL.....	64
ARTICLE 29.	JOINT OPERATING COMMITTEE.....	64
ARTICLE 30.	MISCELLANEOUS	65
30.1	BINDING EFFECT.....	65
30.2	CONFLICTS.....	65
30.3	RULES OF INTERPRETATION	65
30.4	ENTIRE AGREEMENT.....	66
30.5	NO THIRD PARTY BENEFICIARIES	66

30.6	WAIVER	66
30.7	HEADINGS	66
30.8	MULTIPLE COUNTERPARTS	66
30.9	AMENDMENT	66
30.10	MODIFICATION BY THE PARTIES	66
30.11	RESERVATION OF RIGHTS	67
30.12	NO PARTNERSHIP.....	67
30.13	JOINT AND SEVERAL OBLIGATIONS.....	67

APPENDICES

Appendix A-1	Interconnection Facilities, JPP Network Upgrades, and Distribution Upgrades for Phase A of the Interconnection Project
Appendix A-2	Interconnection Facilities, JPP Network Upgrades, and Distribution Upgrades for Phase B of the Interconnection Project
Appendix A-3	SDG&E Network Upgrades for Phase B of the Interconnection Project
Appendix B-1	Milestones for Interconnection Facilities and JPP Network Upgrades for Phase A of the Interconnection Project
Appendix B-2	Milestones for Interconnection Facilities and JPP Network Upgrades for Phase B of the Interconnection Project
Appendix B-3	Milestones for SDG&E Network Upgrades for Phase B of the Interconnection Project
Appendix C	Interconnection Details
Appendix D	Security Arrangements Details
Appendix E	Commercial Operation Date
Appendix F	Addresses for Delivery of Notices and Billings
Appendix G	Requirements of a Wind Generating Plant
Appendix H	Reliability Management System Agreement

LARGE GENERATOR INTERCONNECTION AGREEMENT

THIS LARGE GENERATOR INTERCONNECTION AGREEMENT

("Agreement") is made and entered into this ____ day of _____ 20__, by and between Agua Caliente Solar, LLC, to which NextLight Renewable Power, LLC ("NextLight") has duly assigned its Interconnection Requests only as to Phase A of the Generating Facility, and North Gila River Development, LLC, to which NextLight has duly assigned its Interconnection Request submitted only to APS only as to Phase B of the Generating Facility, each of which is a corporation organized and existing under the laws of the State of Delaware, (collectively Agua Caliente Solar, LLC and North Gila River Development, LLC are the "Interconnection Customer" with a Large Generating Facility), and Arizona Public Service Company ("APS"), a corporation organized and existing under the laws of the State of Arizona, Imperial Irrigation District ("IID"), an irrigation district organized under the Water Code of the State of California, San Diego Gas & Electric Company ("SDG&E"), a corporation organized under the laws of the State of California, and California Independent System Operator Corporation ("CAISO"), a nonprofit public benefit corporation organized and existing under the laws of California. Interconnection Customer, APS, IID, SDG&E and CAISO each may be referred to as a "Party" or collectively as the "Parties."

Recitals

WHEREAS, APS and SDG&E entered into the Arizona Transmission System Participation Agreement, dated June 24, 1981 ("Participation Agreement");

WHEREAS, APS, IID, and SDG&E entered into Amendment No. 1 to the Participation Agreement, dated January 22, 1985 ("Amendment No. 1"), pursuant to which SDG&E assigned and transferred an undivided interest in the Arizona Transmission System to IID;

WHEREAS, APS, IID, and SDG&E ("Joint Participants" or "Transmission Owners") own the Joint Participation Project ("JPP") as set forth in the Participation Agreement, amended by Amendment No. 1;

WHEREAS, APS acts as the Operating Agent of the JPP pursuant to the Participation Agreement, as amended;

WHEREAS, APS and the CAISO are parties to the Interconnected Control Area Operating Agreement, dated November 26, 1997;

WHEREAS, APS, IID, SDG&E, and the CAISO provide transmission service on their respective Transmission Systems;

WHEREAS, Interconnection Customer intends to own, lease and/or control and operate the Generating Facility identified as a Large Generating Facility in Appendix C to this Agreement;

WHEREAS, NextLight, submitted an Interconnection Request for such Large Generating Facility to APS on February 22, 2008, and also submitted an Interconnection Request for Phase A of the Large Generating Facility to CAISO on June 2, 2008;

WHEREAS, NextLight and APS, on behalf of the Joint Participants, entered into an Engineering & Procurement Agreement dated March 30, 2010, to begin design and procurement work for certain Interconnection Facilities to be constructed pursuant to this Agreement and NextLight duly assigned the Engineering & Procurement Agreement to Agua Caliente Solar, LLC;

WHEREAS, the Parties have agreed to enter into this Agreement for the purpose of interconnecting the Large Generating Facility with the JPP; and

WHEREAS, all Parties that are public utilities subject to the jurisdiction of the Federal Energy Regulatory Commission (“FERC”) will file this Agreement simultaneously, as a service agreement under their respective Tariffs.

NOW, THEREFORE, in consideration of and subject to the mutual covenants contained herein, it is agreed:

When used in this Agreement, terms with initial capitalization that are not defined in Article 1 shall have the meanings specified in the Article in which they are used or in the APS Open Access Transmission Tariff or the CAISO Tariff, as applicable.

When an Article of this Agreement contains the phrase “THIS ARTICLE IS NOT APPLICABLE TO THIS AGREEMENT,” or “THIS SECTION IS NOT APPLICABLE TO THIS AGREEMENT,” or “THIS PARAGRAPH IS NOT APPLICABLE TO THIS AGREEMENT,” or when an Appendix to this Agreement contains the phrase “THIS APPENDIX IS NOT APPLICABLE TO THIS AGREEMENT,” the Article, Section, Paragraph or Appendix will have no force and effect with respect to this Agreement.

Article 1. Definitions

Adverse System Impact shall mean the negative effects due to technical or operational limits on conductors or equipment being exceeded that may compromise the safety and reliability of the electric system.

Affected System shall mean an electric system other than the APS or SDG&E's Transmission Systems or IID's share of the JPP that may be affected by the proposed interconnection.

Affected System Operator shall mean the entity that operates an Affected System.

Affected System Construction and Operation Agreement shall mean an agreement between the Interconnection Customer and IID to pay the costs of Network Upgrades, for either of the Project Phases, to IID's Transmission System, other than IID's share of the JPP, and to provide for repayment of amounts advanced to IID with transmission rate credits when transmission service is taken on IID's Transmission System.

Affected System Study shall mean an engineering study that evaluates the impacts of the proposed interconnection of either Project Phase on the safety and reliability of the Transmission System owned by IID, other than IID's share of the JPP, and provides a list of facilities that are required as a result of proposed interconnection, along with an estimate of cost responsibility and time to construct. This Affected System Study may be performed, at IID's option, either serially or in a cluster.

Affected System Study Agreement shall mean an agreement between the Interconnection Customer and IID whereby IID will perform and Interconnection Customer will pay the costs of an Affected System Study. The total costs will be pro rated to the extent IID performs the Affected System Study in a cluster for multiple generators seeking to interconnect to the CAISO controlled grid, with Interconnection Customer allocated a proportionate share of the total costs.

Affiliate shall mean, with respect to a corporation, partnership or other entity, each such other corporation, partnership or other entity that directly or indirectly, through one or more intermediaries, controls, is controlled by, or is under common control with, such corporation, partnership or other entity.

Ancillary Services shall mean those services that are necessary to support the transmission of capacity and energy from resources to loads while maintaining reliable operation of the Transmission System in accordance with Good Utility Practice.

Applicable Laws and Regulations shall mean all duly promulgated applicable federal, state and local laws, regulations, rules, ordinances, codes, decrees, judgments, directives, or judicial or administrative orders, permits and other duly authorized actions of any Governmental Authority.

Applicable Reliability Council shall mean the Western Electricity Coordinating Council or its successor.

Applicable Reliability Standards shall mean the requirements and guidelines of NERC, the Applicable Reliability Council, and the applicable Balancing Authority.

Balancing Authority shall mean the responsible entity that integrates resource plans ahead of time, maintains load-interchange-generation balance within a Balancing Authority Area, and supports interconnection frequency in real time.

Balancing Authority Area shall mean the collection of generation, transmission, and loads within the metered boundaries of the Balancing Authority. The Balancing Authority maintains load resource balance within this area.

Base Case shall mean the base case power flow, short circuit, and stability data bases used for the Interconnection Studies by APS, the CAISO and its designees, or Interconnection Customer.

Breach shall mean the failure of a Party to perform or observe any material term or condition of this Agreement.

Breaching Party shall mean a Party that is in Breach of this Agreement.

Business Day shall mean Monday through Friday, excluding Federal Holidays and the day after Thanksgiving Day.

Calendar Day shall mean any day including Saturday, Sunday or a Federal Holiday.

CAISO Interconnection Service shall have the meaning set forth in Article 4.1.1.

Clustering shall mean the process whereby a group of Interconnection Requests is studied together, instead of serially, for the purpose of conducting the Interconnection System Impact Study.

Commercial Operation shall mean the status of a Project Block at a Generating Facility that has commenced generating electricity for sale, excluding electricity generated during Trial Operation.

Commercial Operation Date shall mean the date on which the Interconnection Customer declares completion of all Project Blocks within a Project Phase, as described in Appendix E to this Agreement and in accordance with the implementation plan agreed to by the Parties for multiple Project Blocks at the Generating Facility.

Confidential Information shall mean any confidential, proprietary or trade secret information of a plan, specification, pattern, procedure, design, device, list, concept, policy or compilation relating to the present or planned business of a Party, which is designated as confidential by the Party supplying the information, whether conveyed orally, electronically, in writing, through inspection, or otherwise, subject to Article 22.1.2.

Default shall mean the failure of a Breaching Party to cure its Breach in accordance with Article 17 of this Agreement.

Dispute Resolution shall mean the procedure for resolution of a dispute between the Parties in which they will first attempt to resolve the dispute on an informal basis.

Distribution System shall mean each of the respective facilities and equipment of APS, IID or SDG&E used to transmit electricity to ultimate usage points such as homes and industries directly from nearby generators or from interchanges with higher voltage transmission networks which transport bulk power over longer distances. The voltage levels at which distribution systems operate differ among areas.

Distribution Upgrades shall mean the additions, modifications, and upgrades to the Distribution System at or beyond the Point of Interconnection to facilitate interconnection of the Generating Facility and render the transmission service necessary to effect Interconnection Customer's wholesale sale of electricity in interstate commerce. Distribution Upgrades do not include Interconnection Facilities.

Effective Date shall mean the date on which this Agreement becomes effective upon execution by the Parties subject to acceptance by FERC, or if filed unexecuted pursuant to Section 205 of the Federal Power Act, upon the date specified by FERC, for those Parties which are FERC-jurisdictional public utilities; provided, however, that, as applied to IID, the Effective Date of this Agreement shall not commence until the Agreement is actually executed by IID, either voluntarily or pursuant to a lawful order issued by FERC in accordance with Sections 210 and 212 of the Federal Power Act.

Emergency Condition shall mean a condition or situation: (1) that in the judgment of the Party making the claim is imminently likely to endanger life or property; or (2) that, in the case of a Transmission Owner or the CAISO, is imminently likely (as determined in a non-discriminatory manner) to cause a material adverse effect on the security of, or damage to its Transmission System, its Interconnection Facilities or the electric systems of others to which its Transmission System is directly connected; or (3) that, in the case of Interconnection Customer, is imminently likely (as determined in a non-discriminatory manner) to cause a material adverse effect on the security of, or damage to, the Generating Facility or Interconnection Customer's Interconnection Facilities. System restoration and black start shall be considered Emergency Conditions; provided, that Interconnection Customer is not obligated by this Agreement to possess black start capability.

Energy Resource Interconnection Service shall mean an Interconnection Service that allows the Interconnection Customer to connect its Generating Facility to the APS Transmission System and IID's share of the JPP to be eligible to deliver the Generating Facility's electric output using the existing firm or nonfirm capacity of the APS Transmission System and IID's share of the JPP on an as available basis. Energy Resource Interconnection Service in and of itself does not convey transmission service.

Engineering & Procurement (E&P) Agreement shall mean an agreement between NextLight and APS, on behalf of the Transmission Owners pursuant to the Participation Agreement, to begin engineering and procurement of long lead-time items necessary for the establishment of the interconnection in order to advance the implementation of the Interconnection Requests for Phase A of the Interconnection Project, which has been duly assigned to Agua Caliente Solar, LLC.

Environmental Law shall mean Applicable Laws or Regulations relating to pollution or protection of the environment or natural resources.

Federal Power Act shall mean the Federal Power Act, as amended, 16 U.S.C. §§ 791a et seq.

FERC shall mean the Federal Energy Regulatory Commission or its successor.

Force Majeure shall mean any act of God, labor disturbance, act of the public enemy, war, insurrection, riot, fire, storm or flood, earthquake, explosion, breakage or accident to machinery or equipment, any order, regulation or restriction imposed by governmental, military or lawfully established civilian authorities, or any other cause beyond a Party's control. A Force Majeure event does not include acts of negligence or intentional wrongdoing by the Party claiming Force Majeure.

Generating Facility shall mean Interconnection Customer's device for the production of electricity identified in the Interconnection Request(s), but shall not include the Interconnection Customer's Interconnection Facilities. The Generating Facility consists of Phase A of the Generating Facility and Phase B of the Generating Facility.

Generating Facility Capacity shall mean the net capacity of the Generating Facility and the aggregate net capacity of the Generating Facility where it includes multiple energy production devices.

Good Utility Practice shall mean any of the practices, methods and acts engaged in or approved by a significant portion of the electric utility industry during the relevant time period, or any of the practices, methods and acts which, in the exercise of reasonable judgment in light of the facts known at the time the decision was made, could have been expected to accomplish the desired result at a reasonable cost consistent with good business practices, reliability, safety and expedition. Good Utility Practice is not intended to be any one of a number of the optimum practices, methods, or acts to the exclusion of all others, but rather to be acceptable practices, methods, or acts generally accepted in the region.

Governmental Authority shall mean any federal, state, local or other governmental regulatory or administrative agency, court, commission, department, board, or other governmental subdivision, legislature, rulemaking board, tribunal, or other governmental authority having jurisdiction over the Parties, their respective facilities, or the respective services they provide, and exercising or entitled to exercise any administrative, executive, police, or taxing authority or power; provided, however, that such term does not include Interconnection Customer, Transmission Owners, the CAISO, or any Affiliate thereof.

Hazardous Substances shall mean any chemicals, materials or substances defined as or included in the definition of "hazardous substances," "hazardous wastes," "hazardous materials," "hazardous constituents," "restricted hazardous materials," "extremely hazardous substances," "toxic substances," "radioactive substances," "contaminants," "pollutants," "toxic pollutants" or words of similar meaning and regulatory effect under any applicable Environmental Law, or any other chemical, material or substance, exposure to which is prohibited, limited or regulated by any applicable Environmental Law.

Initial Synchronization Date shall mean the date upon which the first Project Block of a Project Phase is initially synchronized and upon which Trial Operation begins.

In-Service Date shall mean the date upon which the Interconnection Customer reasonably expects it will be ready to begin use of the Transmission Owners' Interconnection Facilities to obtain back feed power.

Interconnection Customer shall mean Agua Caliente Solar LLC, to which NextLight has duly assigned its Interconnection Requests for Phase A of the Generating Facility, and North Gila River Development, LLC, to which NextLight has duly assigned its Interconnection Request submitted only to APS for Phase B of the Generating Facility, and their successors and assigns.

Interconnection Customer's Interconnection Facilities shall mean all facilities and equipment, as identified in Appendices A-1 and A-2 of this Agreement, that are located between the Generating Facility and the Point of Change of Ownership, including any modification, addition, or upgrades to such facilities and equipment necessary to physically and electrically interconnect the Generating Facility to the JPP. Interconnection Customer's Interconnection Facilities are sole use facilities.

Interconnection Facilities shall mean the Transmission Owners' Interconnection Facilities and the Interconnection Customer's Interconnection Facilities. Collectively, Interconnection Facilities include all facilities and equipment between the Generating Facility and the Point of Interconnection, including any modification, additions or upgrades that are necessary to physically and electrically interconnect the Generating Facility to the JPP. Interconnection Facilities are sole use facilities and shall not include Distribution Upgrades, Stand Alone Network Upgrades or Network Upgrades.

Interconnection Facilities Study shall mean a study conducted by APS or a third party consultant for the Interconnection Customer to determine a list of facilities (including Transmission Owners' Interconnection Facilities and Network Upgrades to the JPP as identified in the Interconnection System Impact Study), the cost of those facilities, and the time required to interconnect the Generating Facility with the JPP; the scope of the study is defined in Section 8 of the APS Large Generator Interconnection Procedures.

Interconnection Feasibility Study shall mean a preliminary evaluation of the system impact and cost of interconnecting the Generating Facility to the JPP, the scope of which is described in Section 6 of the APS Large Generator Interconnection Procedures.

Interconnection Financial Security shall have the meaning assigned to it in Section 1.2 of the CAISO's Large Generator Interconnection Procedures.

Interconnection Request shall mean a request, in the form of Appendix 1 to the Large Generator Interconnection Procedures, in accordance with the APS or CAISO Tariffs, to interconnect a new Generating Facility, or to increase the capacity of, or make a Material Modification to the operating characteristics of, an existing Generating Facility that is interconnected with the JPP. The Interconnection Customer made an Interconnection Request to APS for both Phase A of the Generating Facility and Phase B of the Generating Facility and an Interconnection Request to the CAISO only for Phase A of the Generating Facility. The Interconnection Customer did not make an Interconnection Request to IID.

Interconnection Service shall mean the service provided by the Transmission Owners and the CAISO associated with interconnecting the Interconnection Customer's Generating Facility to the JPP and enabling them to receive electric energy and capacity from the Generating Facility at the Point of Interconnection, pursuant to the terms of this Agreement and the Tariffs of APS, IID, SDG&E, and the CAISO.

Interconnection Study shall mean any of the following studies: (1) the Interconnection Feasibility Study, the Interconnection System Impact Study, or the Interconnection Facilities Study described in the APS Large Generator Interconnection Procedures; or (2) the Phase I Interconnection Study or the Phase II Interconnection Study described in the CAISO Large Generator Interconnection Procedures.

Interconnection System Impact Study shall mean an engineering study that evaluates the impact of the proposed interconnection on the safety and reliability of Transmission Owners' Transmission Systems and, if applicable, an Affected System. The study shall identify and detail the system impacts that would result if the Generating Facility were interconnected without project modifications or system modifications, focusing on the Adverse System Impacts identified in the Interconnection Feasibility Study, or to study potential impacts, including but not limited to those identified in the Scoping Meeting as described in the APS Large Generator Interconnection Procedures.

Interconnection System Impact Study Agreement shall mean the form of agreement contained in the Large Generator Interconnection Procedures of APS for conducting an Interconnection System Impact Study.

IRS shall mean the Internal Revenue Service.

Joint Operating Committee shall be a group made up of representatives from Interconnection Customer and APS, on behalf of the Transmission Owners, to coordinate operating and technical considerations of Interconnection Service.

Joint Participation Project (JPP) shall mean the transmission facilities jointly owned by APS, IID and SDG&E pursuant to the Arizona Transmission System Participation Agreement, as amended.

Large Generating Facility shall mean a Generating Facility having a Generating Facility Capacity of more than 20 MW.

Large Generator Interconnection Procedures (LGIP) shall mean the interconnection procedures applicable to an Interconnection Request pertaining to a Large Generating Facility that are included in the APS or the CAISO Tariff. With respect to the Interconnection Request made to the CAISO for Phase A of the Generating Facility, the applicable LGIP is the LGIP for Interconnection Requests in a Queue Cluster Window, which is found in CAISO Tariff Appendix Y.

Loss shall mean any and all damages, losses and claims, including claims and actions relating to injury to or death of any person or damage to property, demand, suits, recoveries, costs and expenses, court costs, attorney fees, and all other obligations by or to third parties.

Material Modification shall mean those modifications that have a material impact on the cost or timing of any Interconnection Request or any other valid interconnection request with a later queue priority date.

Metering Equipment shall mean all metering equipment installed or to be installed for measuring the output at the Generating Facility pursuant to this Agreement at the metering points, including but not limited to instrument transformers, MWh-meters, data acquisition equipment, transducers, remote terminal unit, communications equipment, phone lines, and fiber optics.

NERC shall mean the North American Electric Reliability Corporation or its successor organization.

Network Resource shall mean any designated generating resource owned, purchased, or leased by a Network Customer under the APS Network Integration Transmission Service Tariff, or the IID Open Access Transmission Tariff. Network Resources do not include any resource, or any portion thereof, that is committed for sale to third parties or otherwise cannot be called upon to meet the Network Customer's Network Load on a non-interruptible basis.

Network Resource Interconnection Service shall mean an Interconnection Service that allows an interconnection customer to integrate its Large Generating Facility with the APS Transmission System or IID's share of the JPP in a manner comparable to that in which APS or IID integrates its generating facilities to serve native load customers. Network Resource Interconnection Service in and of itself does not convey transmission service.

Network Upgrades shall mean the additions, modifications, and upgrades to the Transmission Owners' and CAISO's Transmission Systems required at or beyond the point at which the Interconnection Facilities connect to the JPP to accommodate the interconnection of the Large Generating Facility to the Transmission Owners' and the CAISO's Transmission Systems.

Notice of Dispute shall mean a written notice of a dispute or claim that arises out of or in connection with this Agreement or its performance.

Operating Agent of the JPP shall mean APS as the entity designated as the operating agent of the JPP pursuant to the Participation Agreement.

Ownership Interests shall mean the ownership interests of APS, IID and SDG&E in the JPP, as set forth in the Participation Agreement, as amended, and for purposes of this Agreement, APS, 11 percent; IID, 12.78 percent; and SDG&E, 76.22 percent.

Party or Parties shall mean Transmission Owner(s), the CAISO, Interconnection Customer or the applicable combination of the above.

Phase I Interconnection Study shall have the meaning set forth in the CAISO Tariff as of the effective date of this Agreement.

Phase II Interconnection Study shall have the meaning set forth in the CAISO Tariff as of the effective date of this Agreement.

Phase A of the Generating Facility shall mean no more than 290 MW (net) of solar photovoltaic units installed at the site of the Generating Facility, as described in Appendix C.

Phase B of the Generating Facility shall mean no more than 210 MW (net) of solar photovoltaic units installed at the site of the Generating Facility, as described in Appendix C, after Phase A of the Generating Facility has been completed.

Phase A of the Interconnection Project shall mean construction of the Interconnection Facilities and Network Upgrades required to interconnect Phase A of the Generating Facility, as described in Appendix A-1.

Phase B of the Interconnection Project shall mean construction of the Interconnection Facilities and Network Upgrades required to interconnect Phase B of the Generating Facility, as described in Appendices A-2 and A-3 and as may be identified in studies provided for in Appendix C.

Point of Change of Ownership shall mean the point, as set forth in Appendices A-1 and A-2 to this Agreement, where the Interconnection Customer's Interconnection Facilities connect to the Transmission Owners' Interconnection Facilities.

Point of Interconnection shall mean the point, as set forth in Appendices A-1 and A-2 to this Agreement, where the Interconnection Facilities connect to the JPP.

Project Block shall mean a portion of the solar photovoltaic units within a Project Phase as described in Appendix B-1 and B-2.

Project Phase shall mean either Phase A of the Generating Facility or Phase B of the Generating Facility.

Queue Position shall mean the order of a valid Interconnection Request, relative to all other pending valid Interconnection Requests, that is established based upon the date and time of receipt of the valid Interconnection Request by APS or the CAISO under its Tariff.

Reasonable Efforts shall mean, with respect to an action required to be attempted or taken by a Party under this Agreement, efforts that are timely and consistent with Good Utility Practice and are otherwise substantially equivalent to those a Party would use to protect its own interests.

Scoping Meeting shall mean the meetings between representatives of the Interconnection Customer and Transmission Owners and the CAISO conducted for the purpose of discussing alternative interconnection options, to exchange information including any transmission data and earlier study evaluations that would be reasonably expected to impact such interconnection options, to analyze such information, and to determine the potential feasible Points of Interconnection.

Site Control shall mean documentation reasonably demonstrating: (1) ownership of, a leasehold interest in, or a right to develop a site for the purpose of constructing the Generating Facility; (2) an option to purchase or acquire a leasehold site for such purpose; or (3) an exclusivity or other business relationship between Interconnection Customer and the entity

having the right to sell, lease or grant Interconnection Customer the right to possess or occupy a site for such purpose.

Small Generating Facility shall mean a Generating Facility that has a Generating Facility Capacity of no more than 20 MW.

Stand Alone Network Upgrades shall mean Network Upgrades that an Interconnection Customer may construct without affecting day-to-day operations of the Transmission System during their construction. The Transmission Owners, the CAISO and the Interconnection Customer must agree as to what constitutes Stand Alone Network Upgrades and identify them in Appendices A-1, A-2, and A-3 to this Agreement.

System Protection Facilities shall mean the equipment, including necessary protection signal communications equipment, that protects (1) the Transmission Owners' and the CAISO's Transmission Systems from faults or other electrical disturbances occurring at the Generating Facility and (2) the Generating Facility from faults or other electrical system disturbances occurring on the Transmission Owners' and the CAISO's Transmission Systems or on other delivery systems or other generating systems to which the Transmission Owners' and the CAISO's Transmission Systems are directly connected.

Tariff shall mean the APS, IID, SDG&E or CAISO tariffs through which open access transmission service and Interconnection Service are offered, as filed with FERC with respect to FERC-jurisdictional public utilities and as posted with respect to IID, and as amended or supplemented from time to time, or any successor tariff.

Transmission Owner(s) shall mean APS, IID and SDG&E, as joint owners of the JPP at the Point of Interconnection. Pursuant to the Participation Agreement, APS is Operating Agent of the JPP and acts on behalf of the Transmission Owners with respect to the JPP.

Transmission Owners' Interconnection Facilities shall mean all facilities and equipment owned, controlled or operated by the Transmission Owners from the Point of Change of Ownership identified in Appendices A-1 and A-2 to the Point of Interconnection as identified in Appendices A-1 and A-2 to this Agreement, including any modifications, additions or upgrades to such facilities and equipment. Transmission Owners' Interconnection Facilities are sole use facilities and shall not include Distribution Upgrades, Stand Alone Network Upgrades or Network Upgrades.

Transmission System shall mean the facilities, including the portion of the JPP, owned, controlled or operated by Transmission Owner or the CAISO that are used to provide transmission service under the respective Tariff.

Trial Operation shall mean the period during which Interconnection Customer is engaged in on-site test operations and commissioning of the first Project Block of each Project Phase prior to Commercial Operation.

Article 2. Effective Date, Term, and Termination

2.1 Effective Date. Except as provided below with respect to IID, this Agreement shall become effective upon execution by the Parties and acceptance for filing by FERC, or if filed unexecuted under Section 205 of the Federal Power Act, upon the date specified by

FERC for the Transmission Owners that are FERC-jurisdictional public utilities and the CAISO. Such Transmission Owners and the CAISO shall promptly submit this Agreement for filing with FERC upon execution in accordance with Article 3.1. The Parties acknowledge that IID is not a public utility subject to FERC's jurisdiction under Section 205 or 206 of the Federal Power Act. Therefore, as applied to IID, the Effective Date for the Agreement shall not commence until the later of the date the Agreement is executed by IID, either voluntarily or pursuant to a lawful order issued by FERC in accordance with Sections 210 and 212 of the Federal Power Act, and the date the Agreement is accepted for filing with regard to the Transmission Owners that are FERC-jurisdictional and the CAISO.

2.2 Term of Agreement. Subject to the provisions of Article 2.3, this Agreement shall remain in effect for a period of forty (40) years from the Effective Date and shall be automatically renewed for each successive one-year period thereafter.

2.3 Termination Procedures.

2.3.1 Written Notice. This Agreement may be terminated by (i) Interconnection Customer after giving all other Parties ninety (90) Calendar Days advance written notice, or (ii) by APS, on behalf of the Transmission Owners, or the CAISO notifying FERC after the Generating Facility permanently ceases Commercial Operation. Notice of termination by the Interconnection Customer must be provided by both of the entities comprising the Interconnection Customer.

2.3.2 Default. A Party may terminate this Agreement in accordance with Article 17.

2.3.3 Notwithstanding Articles 2.3.1 and 2.3.2, no termination shall become effective until the Parties have complied with all Applicable Laws and Regulations applicable to such termination, including any required filing with FERC of a notice of termination of this Agreement, which notice has been accepted for filing by FERC. For clarity and avoidance of ambiguity, IID is not a jurisdictional public utility required to file a notice of termination under Section 205 or 206 of the Federal Power Act prior to terminating its participation in this Agreement in accordance with the terms of such Agreement.

2.4 Termination Costs

Upon receipt of a notice of the termination of this Agreement pursuant to Article 2.3 above, the Transmission Owners and the CAISO will promptly determine the total cost responsibility of the Interconnection Customer. If, as of the date of receipt of such notice of termination, the Interconnection Customer has not already paid its share of Network Upgrade costs, including those set forth in Appendices A-1, A-2, and A-3, APS, as the Operating Agent of the JPP, will enforce the financial security rights of APS and IID pursuant to this Agreement and SDG&E will cause Interconnection Customer's Interconnection Financial Security associated with its cost responsibility for SDG&E's non-JPP Network Upgrades and SDG&E's share of the JPP Network Upgrades set forth in Appendices A-1, A-2, and A-3 to be liquidated, in accordance with Section 9.4 of the CAISO's Large Generator Interconnection Procedures.

The Interconnection Customer will also be responsible for all costs incurred or irrevocably committed to be incurred in association with the construction of the Transmission Owners' Interconnection Facilities (including any cancellation costs relating to orders or contracts for Interconnection Facilities and equipment) and other such expenses for which the Transmission Owners or the CAISO have incurred expenses or have irrevocably committed to incur expenses and have not been reimbursed by the Interconnection Customer, as of the date of receipt of the notice of termination, subject to the limitations set forth in this Article 2.4. Nothing in this Article 2.4 shall limit the Parties' rights under Article 17. If, as of the date of the receipt of the notice of termination, the Interconnection Customer has not already reimbursed the Transmission Owners and the CAISO for costs incurred to construct the Transmission Owners' Interconnection Facilities, APS, as Operating Agent of the JPP, shall enforce the financial security rights of APS and IID pursuant to this Agreement and SDG&E will liquidate the Interconnection Customer's Interconnection Financial Security associated with the construction of SDG&E's share of the Transmission Owners' Interconnection Facilities, in accordance with Section 9.4 of the CAISO Large Generator Interconnection Procedures.

For cost responsibility for Interconnection Facilities and Network Upgrades to the JPP set forth in Appendices A-1 and A-2, the Transmission Owners' financial security rights shall be enforced in accordance with the provisions for enforcement of financial security set forth in Appendices A-1 and A-2.

If the amount of the financial security, including the Interconnection Financial Security, liquidated by Transmission Owners under this Article 2.4 is insufficient to compensate Transmission Owners and the CAISO for actual costs associated with the construction of the Transmission Owners' Interconnection Facilities and Network Upgrades contemplated in this Article, any additional amounts will be the responsibility of the Interconnection Customer. Any such additional amounts due from the Interconnection Customer beyond the amounts covered by its financial security, including its Interconnection Financial Security, will be due to the Transmission Owners immediately upon termination of this Agreement, subject, with respect to amounts due SDG&E, to the provisions of Section 9.4 of the CAISO Large Generator Interconnection Procedures.

If the amount of the Interconnection Financial Security exceeds the Interconnection Customer's cost responsibility under Section 9.4 of the CAISO's Large Generator Interconnection Procedures, such excess amount will be released to the Interconnection Customer by SDG&E in accordance with Section 9.4 of the CAISO's Large Generator Interconnection Procedures.

Notwithstanding the foregoing, in the event of termination of this Agreement, the Parties shall use commercially Reasonable Efforts to mitigate the costs, damages and charges arising as a consequence of termination. Upon termination of this Agreement, unless otherwise ordered or approved by FERC to the extent FERC possesses jurisdiction over the public utilities which are Parties to this Agreement:

2.4.1 With respect to any portion of Transmission Owners' Interconnection Facilities that have not yet been constructed or installed, Transmission Owners shall to the extent possible and with Interconnection Customer's authorization cancel any pending orders of, or return, any materials or equipment for, or contracts for

construction of, such Interconnection Facilities; provided that in the event Interconnection Customer elects not to authorize such cancellation, Interconnection Customer shall assume all payment obligations with respect to such materials, equipment, and contracts, and Transmission Owners shall deliver such material and equipment, and, if necessary, assign such contracts, to Interconnection Customer as soon as practicable, at Interconnection Customer's expense. To the extent that Interconnection Customer has already paid Transmission Owners for any or all such costs of materials or equipment not taken by Interconnection Customer, Transmission Owners shall promptly refund such amounts to Interconnection Customer, less any costs, including penalties incurred by Transmission Owners to cancel any pending orders of or return such materials, equipment, or contracts.

- 2.4.2** Transmission Owners may, at their collective option, retain any portion of such materials, equipment, or facilities that Interconnection Customer chooses not to accept delivery of, in which case Transmission Owners shall be responsible for all costs associated with procuring such materials, equipment, or facilities.
- 2.4.3** With respect to any portion of the Interconnection Facilities, and any other facilities already installed or constructed pursuant to the terms of this Agreement, Interconnection Customer shall be responsible for all costs associated with the removal, relocation or other disposition or retirement of such materials, equipment, or facilities.

- 2.5** **Disconnection.** Upon termination of this Agreement as to Phase A of the Interconnection Project, APS, on behalf of Transmission Owners, will take all appropriate steps to disconnect Phase A of the Interconnection Project from the JPP. All costs required to effectuate such disconnection shall be borne by the terminating Party, unless such termination resulted from the non-terminating Party's Default of this Agreement or such non-terminating Party otherwise is responsible for these costs under this Agreement.

Upon termination of this Agreement as to Phase B of the Interconnection Project, APS, on behalf of Transmission Owners will take all appropriate steps to disconnect Phase B of the Interconnection Project from the JPP. All costs required to effectuate such disconnection shall be borne by the terminating Party, unless such termination resulted from the non-terminating Party's Default of this Agreement or such non-terminating Party otherwise is responsible for these costs under this Agreement.

- 2.6** **Survival.** This Agreement shall continue in effect after termination to the extent necessary to provide for final billings and payments and for costs incurred hereunder, including billings and payments pursuant to this Agreement; to permit the determination and enforcement of liability and indemnification obligations arising from acts or events that occurred while this Agreement was in effect; and to permit the Parties to have access to the lands of another Party pursuant to this Agreement or other applicable agreements, to disconnect, remove or salvage its own facilities and equipment.

Article 3. Regulatory Filings

- 3.1 Filing.** The CAISO and Transmission Owners that are FERC-jurisdictional public utilities shall file this Agreement (and any amendment hereto) with the appropriate Governmental Authority, if required. Interconnection Customer may request that any information so provided be subject to the confidentiality provisions of Article 22. If Interconnection Customer has executed this Agreement, or any amendment thereto, Interconnection Customer shall reasonably cooperate with Transmission Owners and the CAISO with respect to such filing and to provide any information reasonably requested by Transmission Owners and the CAISO needed to comply with applicable regulatory requirements. For clarity and avoidance of ambiguity, IID is not a jurisdictional public utility subject to a filing requirement under Section 205 of the Federal Power Act.

Article 4. Scope of Service

- 4.1 Interconnection Product Options.** Interconnection Customer has selected Energy Resource Interconnection Service from APS to interconnect to the APS Transmission System and IID's share of the JPP, and Interconnection Service from the CAISO.

- 4.1.1 CAISO Interconnection Service.** Interconnection Service provided by the CAISO and SDG&E allows the Interconnection Customer to connect the Large Generating Facility to the CAISO's Transmission System and be eligible to deliver the Large Generating Facility's output using the available capacity of the CAISO's Transmission System pursuant to the CAISO Tariff.

Interconnection Service does not necessarily provide the Interconnection Customer with the capability to physically deliver the output of its Large Generating Facility to any particular load on the CAISO Transmission System without incurring congestion costs. In the event of transmission constraints on the CAISO Transmission System, the Interconnection Customer's Large Generating Facility shall be subject to the applicable congestion management procedures in the CAISO Tariff in the same manner as all other resources.

- 4.1.2 Energy Resource Interconnection Service.**

4.1.2.1 The Product. Energy Resource Interconnection Service from APS and IID allows Interconnection Customer to connect the Large Generating Facility to the JPP and be eligible to deliver the Large Generating Facility's output using available capacity on the existing firm or non-firm capacity of the APS Transmission System and IID's share of the JPP on an "as available" basis.

4.1.2.2 Transmission Delivery Service Implications. Under Energy Resource Interconnection Service, Interconnection Customer will be eligible to inject power from the Large Generating Facility into and deliver power across the APS Transmission System and IID's share of the JPP on an "as available" basis up to the amount of MWs identified in the applicable stability and steady state studies to the extent the upgrades initially required to qualify for Energy Resource Interconnection Service have been constructed. No transmission delivery service from the Large Generating Facility is assured, but Interconnection Customer may obtain Point-to-Point Transmission Service, Network Integration Transmission

Service, or be used for secondary network transmission service, pursuant to the APS Tariff or Transmission Service on IID's share of the JPP pursuant to the IID Tariff, up to the maximum output identified in the stability and steady state studies. In order for Interconnection Customer to obtain the right to deliver or inject energy beyond the Large Generating Facility Point of Interconnection or to improve its ability to do so, transmission delivery service must be obtained pursuant to the provisions of the APS or IID Tariffs. The Interconnection Customer's ability to inject its Large Generating Facility output beyond the Point of Interconnection, therefore, will depend on the existing capacity of the APS or IID Transmission Systems at such time as a transmission service request is made that would accommodate such delivery. The provision of firm Point-to-Point Transmission Service or Network Integration Transmission Service may require the construction of additional Network Upgrades.

4.1.3 Network Resource Interconnection Service.

4.1.3.1 The Product. [THIS SECTION IS NOT APPLICABLE TO THIS AGREEMENT.]

4.1.3.2 Transmission Delivery Service Implications. [THIS SECTION IS NOT APPLICABLE TO THIS AGREEMENT.]

4.2 Provision of Service. APS, on behalf of the Transmission Owners, and the CAISO shall provide Interconnection Service for the Large Generating Facility at the Point of Interconnection.

4.3 Performance Standards. Each Party shall perform all of its obligations under this Agreement in accordance with Applicable Laws and Regulations, Applicable Reliability Standards, and Good Utility Practice, and to the extent a Party is required or prevented or limited in taking any action by such regulations and standards, such Party shall not be deemed to be in Breach of this Agreement for its compliance therewith. If such Party is a Transmission Owner or the CAISO, then that Party shall negotiate an amendment to the Agreement and, if it is a FERC-jurisdictional public utility, shall submit the amendment to FERC for approval. For clarity and avoidance of ambiguity, IID is not a FERC-jurisdictional public utility subject to a filing requirement under Section 205 of the Federal Power Act.

4.4 No Transmission Delivery Service. The execution of this Agreement does not constitute a request for, nor the provision of, any transmission delivery service under any applicable Tariff, and does not convey any right to deliver electricity to any specific customer or point of delivery.

4.5 Interconnection Customer Provided Services. The services provided by Interconnection Customer under this Agreement are set forth in Article 9.6 and Article 13.5.1. Interconnection Customer shall be paid for such services in accordance with Article 11.6.

Article 5. Interconnection Facilities Engineering, Procurement, and Construction

5.1 Options. Unless otherwise mutually agreed to between the Parties, Interconnection Customer shall select the In-Service Date, Initial Synchronization Date, and Commercial Operation Date; and either Standard Option or Alternate Option set forth below for completion of Transmission Owners' Interconnection Facilities and Network Upgrades as set forth in Appendices A-1, A-2, and A-3, and such dates and selected option shall be set forth in Appendices B-1, B-2, and B-3 Milestones.

5.1.1 Standard Option. APS, on behalf of Transmission Owners shall design, procure, and construct Transmission Owners' Interconnection Facilities and JPP Network Upgrades set forth in Appendices A-1 and A-2, and SDG&E shall design, procure, and construct Network Upgrades set forth in Appendix A-3, in each case using Reasonable Efforts to complete the Transmission Owners' Interconnection Facilities and these Network Upgrades by the dates set forth in Appendices B-1, B-2, and B-3 Milestones. Transmission Owners shall not be required to undertake any action which is inconsistent with their standard safety practices, material and equipment specifications, design criteria and construction procedures, labor agreements, and Applicable Laws and Regulations. In the event APS, on behalf of Transmission Owners, and/or SDG&E, as applicable, reasonably expect that they will not be able to complete Transmission Owners' Interconnection Facilities and Network Upgrades set forth in Appendices A-1, A-2, and A-3 by the specified dates in the Appendices B-1, B-2, and B-3 Milestones, APS, on behalf of Transmission Owners, and/or SDG&E, as applicable, shall promptly provide written notice to Interconnection Customer and shall undertake Reasonable Efforts to meet the earliest dates thereafter.

5.1.2 Alternate Option. [THIS SECTION IS NOT APPLICABLE TO THIS AGREEMENT.]

5.1.3 Option to Build. [THIS SECTION IS NOT APPLICABLE TO THIS AGREEMENT.]

5.1.4 Negotiated Option. [THIS SECTION IS NOT APPLICABLE TO THIS AGREEMENT.]

5.2 General Conditions Applicable to Option to Build. [THIS SECTION IS NOT APPLICABLE TO THIS AGREEMENT.]

5.3 Liquidated Damages. [THIS SECTION IS NOT APPLICABLE TO THIS AGREEMENT.]

5.4 Power System Stabilizers. If the Applicable Reliability Standards, or the guidelines and procedures established by the Applicable Reliability Council, deem a Power System Stabilizer applicable to the type of solar photovoltaic equipment used in the Generating Facility, then the Interconnection Customer shall procure, install, maintain and operate Power System Stabilizers. APS reserves the right to reasonably establish minimum acceptable settings for any installed Power System Stabilizers, subject to the design and operating limitations of the Large Generating Facility. If the Large Generating Facility's Power System Stabilizers are removed from service or not capable of automatic operation, Interconnection Customer shall immediately notify APS and restore the Power

System Stabilizers to operation as soon as possible. APS shall have the right to order the reduction in output or disconnection of the Large Generating Facility if the reliability of the Transmission System would be adversely affected as a result of improperly tuned Power System Stabilizers. The Generating Facility is a solar photovoltaic generator and as such does not have the physical characteristic to which a Power System Stabilizer would apply.

- 5.5 Equipment Procurement.** The Transmission Owners' design of Transmission Owners' Interconnection Facilities and Network Upgrades to the JPP for Phase A of the Interconnection Project, as set forth in Appendix A-1, and partial procurement of certain long-lead equipment for Phase A of the Interconnection Project has been advanced in accordance with the terms of the E & P Agreement dated March 30, 2010. To the extent the design and long lead time procurement work has not been completed pursuant to the E&P Agreement, APS, on behalf of Transmission Owners, shall finish design of Transmission Owners' Interconnection Facilities and Network Upgrades to the JPP and procure necessary equipment pursuant to the terms of this Agreement.
- 5.6 Construction Commencement.** APS, on behalf of Transmission Owners, shall commence construction of Transmission Owners' Interconnection Facilities and Network Upgrades to the JPP for which it is responsible as set forth in Appendices A-1, and A-2, and SDG&E shall commence construction of Network Upgrades to its non-JPP facilities for which it is responsible as set forth in Appendix A-3, as soon as practicable after the following additional conditions are satisfied:
- 5.6.1** Approval of the appropriate Governmental Authority has been obtained for any facilities requiring regulatory approval;
 - 5.6.2** Necessary real property rights and rights-of-way have been obtained, to the extent required for the construction of a discrete aspect of Transmission Owners' Interconnection Facilities and Network Upgrades set forth in Appendices A-1, A-2, and A-3;
 - 5.6.3** Transmission Owners have received written authorization to proceed with construction from Interconnection Customer by the date specified in Appendices B-1, B-2, and B-3 Milestones; and
 - 5.6.4** Interconnection Customer has provided payment and security in accordance with Article 11.5 by the dates specified in Appendices B-1, B-2, and B-3, Milestones.
 - 5.6.5** For Phase B of the Interconnection Project only, the conditions specified in Appendix C also shall be met before construction of Transmission Owners' Interconnection Facilities and Network Upgrades commences for that Project Phase.
- 5.7 Work Progress.** The Parties will keep each other advised periodically as to the progress of their respective design, procurement and construction efforts. Any Party may, at any time, request a progress report from another Party. If, at any time, Interconnection Customer determines that the completion of Transmission Owners' Interconnection Facilities will not be required until after the specified In-Service Date, Interconnection Customer will provide written notice to APS, SDG&E, IID, and the CAISO of such later

date upon which the completion of Transmission Owners' Interconnection Facilities will be required.

- 5.8 Information Exchange.** As soon as reasonably practicable after the Effective Date, Transmission Owners, CAISO and the Interconnection Customer shall exchange information regarding the design and compatibility of the Parties' Interconnection Facilities and compatibility of the Interconnection Facilities with Transmission Owners' and the CAISO's Transmission Systems, and shall work diligently and in good faith to make any necessary design changes.
- 5.9 Limited Operation.** If any of Transmission Owners' Interconnection Facilities or Network Upgrades are not reasonably expected to be completed prior to the Commercial Operation Date of a Project Phase, Transmission Owners and CAISO shall, upon the request and at the expense of Interconnection Customer, perform operating studies on a timely basis to determine the extent to which the Large Generating Facility and Interconnection Customer's Interconnection Facilities may operate prior to the completion of Transmission Owners' Interconnection Facilities or Network Upgrades consistent with Applicable Laws and Regulations, Applicable Reliability Standards, Good Utility Practice, and this Agreement. Transmission Owners and CAISO shall permit Interconnection Customer to operate the Project Phase and Interconnection Customer's Interconnection Facilities in accordance with the results of such studies.
- 5.10 Interconnection Customer's Interconnection Facilities ('ICIF').** Interconnection Customer shall, at its expense, design, procure, construct, own and install the ICIF, as set forth in Appendices A-1 and A-2.
- 5.10.1 Interconnection Customer's Interconnection Facility Specifications.** Interconnection Customer shall submit initial specifications for the ICIF and a Project Phase, including System Protection Facilities, to (i) APS, on behalf of Transmission Owners, and (ii) CAISO at least one hundred eighty (180) Calendar Days prior to the Initial Synchronization Date for the Project Phase; and final specifications for review and comment at least ninety (90) Calendar Days prior to the Initial Synchronization Date for the Project Phase. Transmission Owners and CAISO shall review such specifications to ensure that the ICIF and Project Phase of Large Generating Facility are compatible with the technical specifications, operational control, and safety requirements of Transmission Owners and CAISO and comment on such specifications within thirty (30) Calendar Days of Interconnection Customer's submission. All specifications provided hereunder shall be deemed confidential.
- 5.10.2 Review by Transmission Owners and CAISO.** Transmission Owners and CAISO review of Interconnection Customer's final specifications shall not be construed as confirming, endorsing, or providing a warranty as to the design, fitness, safety, durability or reliability of the Large Generating Facility, or the ICIF. Interconnection Customer shall make such changes to the ICIF as may reasonably be required by Transmission Owners or CAISO, in accordance with Good Utility Practice, to ensure that the ICIF are compatible with the technical specifications, operational control, and safety requirements of Transmission Owners and CAISO.

5.10.3 ICIF Construction. The ICIF shall be designed and constructed in accordance with Good Utility Practice. Within one hundred twenty (120) Calendar Days after the Commercial Operation Date of a Project Phase, unless the Parties agree on another mutually acceptable deadline, Interconnection Customer shall deliver to (i) APS, on behalf of Transmission Owners, and (ii) CAISO “as-built” drawings, information and documents for the ICIF and the applicable Project Phase of the Large Generating Facility, such as: a one-line diagram, a site plan showing the Large Generating Facility and the ICIF, plan and elevation drawings showing the layout of the ICIF, a relay functional diagram, relaying AC and DC schematic wiring diagrams and relay settings for all facilities associated with Interconnection Customer’s step-up transformers, the facilities connecting the Project Phase to the step-up transformers and the ICIF, and the impedances (determined by factory tests) for the associated step-up transformers and the Project Phase. The Interconnection Customer shall provide (i) APS, on behalf of Transmission Owners, and (ii) CAISO specifications for the excitation system, automatic voltage regulator, Large Generating Facility control and protection settings, transformer tap settings, and communications, if applicable. Any deviations from the relay settings, machine specifications, and other specifications originally submitted by the Interconnection Customer shall be assessed by the Transmission Owners and the CAISO pursuant to the appropriate provisions of this Agreement and the APS and CAISO Large Generator Interconnection Procedures.

5.11 Transmission Owners’ Interconnection Facilities Construction. Transmission Owners’ Interconnection Facilities shall be designed and constructed in accordance with Good Utility Practice. Upon request, within one hundred twenty (120) Calendar Days after the Commercial Operation Date, unless the Parties agree on another mutually acceptable deadline, APS, on behalf of Transmission Owners, shall deliver to Interconnection Customer and the CAISO the “as-built” drawings, information and documents for Transmission Owners’ Interconnection Facilities, including appropriate drawings and relay diagrams.

APS, on behalf of Transmission Owners, will obtain control of Transmission Owners’ Interconnection Facilities and Stand Alone Network Upgrades to the JPP upon completion of such facilities.

5.12 Access Rights. Upon reasonable notice and supervision by a Party, and subject to any required or necessary regulatory approvals, a Party (“Granting Party”) shall furnish at no cost to the other Party (“Access Party”) any rights of use, licenses, rights of way and easements with respect to lands owned or controlled by the Granting Party, its agents (if allowed under the applicable agency agreement), or any Affiliate, that are necessary to enable the Access Party to obtain ingress and egress to construct, operate, maintain, repair, test (or witness testing), inspect, replace or remove facilities and equipment to: (i) interconnect the Large Generating Facility with the JPP; (ii) operate and maintain the Large Generating Facility, the Interconnection Facilities and the JPP; and (iii) disconnect or remove the Access Party’s facilities and equipment upon termination of this Agreement. In exercising such licenses, rights of way and easements, the Access Party shall not unreasonably disrupt or interfere with normal operation of the Granting Party’s business and shall adhere to the safety rules and procedures established in advance, as

may be changed from time to time, by the Granting Party and provided to the Access Party.

- 5.13 Lands of Other Property Owners.** If any part of Transmission Owners' Interconnection Facilities and/or Network Upgrades is to be installed on property owned by persons other than Interconnection Customer or Transmission Owners, Transmission Owners shall at Interconnection Customer's expense use efforts, similar in nature and extent to those that they typically undertake on their own behalf or on behalf of their Affiliates, including use of eminent domain authority, and to the extent consistent with state law, to procure from such persons any rights of use, licenses, rights of way and easements that are necessary to construct, operate, maintain, test, inspect, replace or remove Transmission Owners' Interconnection Facilities and/or Network Upgrades upon such property.
- 5.14 Permits.** Transmission Owners and Interconnection Customer shall cooperate with each other in good faith in obtaining all permits, licenses, and authorizations that are necessary to accomplish the interconnection in compliance with Applicable Laws and Regulations. With respect to this paragraph, Transmission Owners shall provide permitting assistance to Interconnection Customer comparable to that provided to Transmission Owners' own, or an Affiliate's generation.
- 5.15 Early Construction of Base Case Facilities.** Interconnection Customer may request Transmission Owners to construct, and Transmission Owners shall construct, using Reasonable Efforts to accommodate Interconnection Customer's In-Service Date, all or any portion of any Network Upgrades required for Interconnection Customer to be interconnected to the JPP which are included in the Base Case of the Interconnection Facilities Study for Interconnection Customer, and which also are required to be constructed for another interconnection customer, but where such construction is not scheduled to be completed in time to achieve Interconnection Customer's In-Service Date.
- 5.16 Suspension.** Interconnection Customer reserves the right, upon written notice to APS, SDG&E, IID and the CAISO, to suspend at any time all work by APS and SDG&E associated with the construction and installation of Transmission Owners' Interconnection Facilities and/or Network Upgrades required under this Agreement, other than Network Upgrades, if any, identified in the Phase II Interconnection Study under the CAISO's Large Generator Interconnection Procedures as common to multiple Generating Facilities, with the condition that the Transmission System shall be left in a safe and reliable condition in accordance with Good Utility Practice and Transmission Owners' safety and reliability criteria, and the Applicable Reliability Standards. In such event, Interconnection Customer shall be responsible for all reasonable and necessary costs which Transmission Owners, (i) have incurred pursuant to this Agreement prior to the suspension and (ii) incur in suspending such work, including any costs incurred to perform such work as may be necessary to ensure the safety of persons and property and the integrity of the Transmission System during such suspension and, if applicable, any costs incurred in connection with the cancellation or suspension of material, equipment and labor contracts which Transmission Owners cannot reasonably avoid; provided, however, that prior to canceling or suspending any such material, equipment or labor contract, Transmission Owners shall obtain Interconnection Customer's authorization to do so.

APS, on behalf of Transmission Owners, with respect to facilities identified on Appendices A-1 and A-2, and SDG&E with respect to facilities identified on Appendix A-3, shall invoice Interconnection Customer for such costs pursuant to Article 12 and shall use due diligence to minimize such costs. In the event Interconnection Customer suspends work required under this Agreement pursuant to this Article 5.16, and has not requested APS, on behalf of Transmission Owners, or SDG&E to recommence the work or has not itself recommenced work required under this Agreement in time to ensure that Commercial Operation of the full Generating Facility Capacity of the Large Generating Facility is no more than three (3) years from the final Commercial Operation Date identified in Appendices B-1, B-2, and B-3, this Agreement shall be deemed terminated and the Interconnection Customer's responsibility for costs of the Transmission Owners' Interconnection Facilities and Network Upgrades set forth in Appendices A-1, A-2, and A-3 will be determined in accordance with Article 2.4. The suspension shall begin on the date the suspension is requested, or the date of the written notice to APS, on behalf of Transmission Owners, for its work or SDG&E for its work, if no effective date is specified other than Network Upgrades, if any, identified in the Phase II Interconnection Study under the CAISO's Large Generator Interconnection Procedures.

5.17 Taxes.

5.17.1 Interconnection Customer Payments Not Taxable. The Parties intend that all payments or property transfers made by Interconnection Customer to Transmission Owners for the installation of Transmission Owners' Interconnection Facilities and the Network Upgrades shall be non-taxable, either as contributions to capital, or as a refundable advance, in accordance with the Internal Revenue Code and any applicable state income tax laws and shall not be taxable as contributions in aid of construction or otherwise under the Internal Revenue Code and any applicable state income tax laws.

5.17.2 Representations and Covenants. In accordance with IRS Notice 2001-82 and IRS Notice 88-129, Interconnection Customer represents and covenants that (i) ownership of the electricity generated at the Large Generating Facility will pass to another party prior to the transmission of the electricity on a Transmission System, (ii) for income tax purposes, the amount of any payments and the cost of any property transferred to Transmission Owners for Transmission Owners' Interconnection Facilities will be capitalized by Interconnection Customer as an intangible asset and recovered using the straight-line method over a useful life of twenty (20) years, and (iii) any portion of Transmission Owners' Interconnection Facilities that is a "dual-use intertie," within the meaning of IRS Notice 88-129, is reasonably expected to carry only a de minimis amount of electricity in the direction of the Large Generating Facility. For this purpose, "de minimis amount" means no more than 5 percent of the total power flows in both directions, calculated in accordance with the "5 percent test" set forth in IRS Notice 88-129. This is not intended to be an exclusive list of the relevant conditions that must be met to conform to IRS requirements for non-taxable treatment.

At a Transmission Owner's request, Interconnection Customer shall provide such Transmission Owner with a report from an independent engineer confirming its

representation in clause (iii), above. Transmission Owners represents and covenant that the cost of Transmission Owners' Interconnection Facilities paid for by Interconnection Customer will have no net effect on the base upon which rates are determined.

5.17.3 Indemnification for the Cost Consequences of Current Tax Liability Imposed Upon the Transmission Owner. Notwithstanding Article 5.17.1, Interconnection Customer shall protect, indemnify and hold harmless each Transmission Owner from the cost consequences of any current tax liability imposed against a Transmission Owner as the result of payments or property transfers made by Interconnection Customer to a Transmission Owner under this Agreement for Interconnection Facilities, as well as any interest and penalties, other than interest and penalties attributable to any delay caused by a Transmission Owner.

Transmission Owner shall not include a gross-up for the cost consequences of any current tax liability in the amounts it charges Interconnection Customer under this Agreement unless (i) Transmission Owner has determined, in good faith, that the payments or property transfers made by Interconnection Customer to Transmission Owner should be reported as income subject to taxation or (ii) any Governmental Authority directs Transmission Owner to report payments or property as income subject to taxation; provided, however, that Transmission Owner may require Interconnection Customer to provide security for Interconnection Facilities, in a form reasonably acceptable to Transmission Owner, in an amount equal to the cost consequences of any current tax liability under this Article 5.17. Interconnection Customer shall reimburse Transmission Owner for such costs on a fully grossed-up basis, in accordance with Article 5.17.4, within thirty (30) Calendar Days of receiving written notification from Transmission Owner of the amount due, including detail about how the amount was calculated.

The indemnification obligation shall terminate at the earlier of (1) the expiration of the ten year testing period and the applicable statute of limitation, as it may be extended by Transmission Owner upon request of the IRS, to keep these years open for audit or adjustment, or (2) the occurrence of a subsequent taxable event and the payment of any related indemnification obligations as contemplated by this Article 5.17.

5.17.4 Tax Gross-Up Amount. Interconnection Customer's liability for the cost consequences of any current tax liability under this Article 5.17 shall be calculated on a fully grossed-up basis. Except as may otherwise be agreed to by the parties, this means that Interconnection Customer will pay Transmission Owner, in addition to the amount paid for the Interconnection Facilities and Network Upgrades, an amount equal to (1) the current taxes imposed on Transmission Owner ("Current Taxes") on the excess of (a) the gross income realized by Transmission Owner as a result of payments or property transfers made by Interconnection Customer to Transmission Owner under this Agreement (without regard to any payments under this Article 5.17) (the "Gross Income Amount") over (b) the present value of future tax deductions for depreciation that will be available as a result of such payments or property transfers (the "Present

Value Depreciation Amount”), plus (2) an additional amount sufficient to permit Transmission Owner to receive and retain, after the payment of all Current Taxes, an amount equal to the net amount described in clause (1).

For this purpose, (i) Current Taxes shall be computed based on Transmission Owner’s composite federal and state tax rates at the time the payments or property transfers are received and Transmission Owner will be treated as being subject to tax at the highest marginal rates in effect at that time (the “Current Tax Rate”), and (ii) the Present Value Depreciation Amount shall be computed by discounting Transmission Owner’s anticipated tax depreciation deductions as a result of such payments or property transfers by Transmission Owner’s current weighted average cost of capital. Thus, the formula for calculating Interconnection Customer’s liability to each respective Transmission Owner pursuant to this Article 5.17.4 can be expressed as follows: $(\text{Current Tax Rate} \times (\text{Gross Income Amount} - \text{Present Value of Tax Depreciation})) / (1 - \text{Current Tax Rate})$. Interconnection Customer’s estimated tax liability in the event taxes are imposed shall be stated in Appendices A-1, A-2, and A-3.

5.17.5 Private Letter Ruling or Change or Clarification of Law. At Interconnection Customer’s request and expense, Transmission Owner shall file with the IRS a request for a private letter ruling as to whether any property transferred or sums paid, or to be paid, by Interconnection Customer to Transmission Owner under this Agreement are subject to federal income taxation. Interconnection Customer will prepare the initial draft of the request for a private letter ruling, and will certify under penalties of perjury that all facts represented in such request are true and accurate to the best of Interconnection Customer’s knowledge. Transmission Owner and Interconnection Customer shall cooperate in good faith with respect to the submission of such request.

Transmission Owner shall keep Interconnection Customer fully informed of the status of such request for a private letter ruling and shall execute either a privacy act waiver or a limited power of attorney, in a form acceptable to the IRS, that authorizes Interconnection Customer to participate in all discussions with the IRS regarding such request for a private letter ruling. Transmission Owner shall allow Interconnection Customer to attend all meetings with IRS officials about the request and shall permit Interconnection Customer to prepare the initial drafts of any follow-up letters in connection with the request.

5.17.6 Subsequent Taxable Events. If, within 10 years from the date on which the relevant Transmission Owner’s Interconnection Facilities are placed in service, (i) Interconnection Customer Breaches the covenants contained in Article 5.17.2, (ii) a “disqualification event” occurs within the meaning of IRS Notice 88-129, or (iii) this Agreement terminates and Transmission Owner retains ownership of the Interconnection Facilities and Network Upgrades, Interconnection Customer shall pay a tax gross-up for the cost consequences of any current tax liability imposed on Transmission Owner, calculated using the methodology described in Article 5.17.4 and in accordance with IRS Notice 90-60.

5.17.7 Contests. In the event any Governmental Authority determines that a Transmission Owner’s receipt of payments or property constitutes income that is

subject to taxation, such Transmission Owner shall notify Interconnection Customer, in writing, within thirty (30) Calendar Days of receiving notification of such determination by a Governmental Authority. Upon the timely written request by Interconnection Customer and at Interconnection Customer's sole expense, such Transmission Owner may appeal, protest, seek abatement of, or otherwise oppose such determination. Upon Interconnection Customer's written request and sole expense, such Transmission Owner may file a claim for refund with respect to any taxes paid under this Article 5.17, whether or not it has received such a determination. Such Transmission Owner reserves the right to make all decisions with regard to the prosecution of such appeal, protest, abatement or other contest, including the selection of counsel and compromise or settlement of the claim, but such Transmission Owner shall keep Interconnection Customer informed, shall consider in good faith suggestions from Interconnection Customer about the conduct of the contest, and shall reasonably permit Interconnection Customer or an Interconnection Customer representative to attend contest proceedings.

Interconnection Customer shall pay to such Transmission Owner on a periodic basis, as invoiced by Transmission Owner, Transmission Owner's documented reasonable costs of prosecuting such appeal, protest, abatement or other contest. At any time during the contest, such Transmission Owner may agree to a settlement either with Interconnection Customer's consent or after obtaining written advice from nationally-recognized tax counsel, selected by such Transmission Owner, but reasonably acceptable to Interconnection Customer, that the proposed settlement represents a reasonable settlement given the hazards of litigation. Interconnection Customer's obligation shall be based on the amount of the settlement agreed to by Interconnection Customer, or if a higher amount, so much of the settlement that is supported by the written advice from nationally-recognized tax counsel selected under the terms of the preceding sentence. The settlement amount shall be calculated on a fully grossed-up basis to cover any related cost consequences of the current tax liability. Any settlement without Interconnection Customer's consent or such written advice will relieve Interconnection Customer from any obligation to indemnify such Transmission Owner for the tax at issue in the contest.

5.17.8 Refund. In the event that (a) a private letter ruling is issued to a Transmission Owner which holds that any amount paid or the value of any property transferred by Interconnection Customer to such Transmission Owner under the terms of this Agreement is not subject to federal income taxation, (b) any legislative change or administrative announcement, notice, ruling or other determination makes it reasonably clear to such Transmission Owner in good faith that any amount paid or the value of any property transferred by Interconnection Customer to such Transmission Owner under the terms of this Agreement is not taxable to such Transmission Owner, (c) any abatement, appeal, protest, or other contest results in a determination that any payments or transfers made by Interconnection Customer to such Transmission Owner are not subject to federal income tax, or (d) if such Transmission Owner receives a refund from any taxing authority for any overpayment of tax attributable to any payment or property transfer made by Interconnection Customer to such Transmission Owner

pursuant to this Agreement, such Transmission Owner shall promptly refund to Interconnection Customer the following:

(i) any payment made by Interconnection Customer under this Article 5.17 to such Transmission Owner for taxes that is attributable to the amount determined to be non-taxable, together with interest thereon,

(ii) interest on any amount paid by Interconnection Customer to such Transmission Owner for such taxes which Transmission Owner did not submit to the taxing authority, calculated in accordance with the methodology set forth in FERC's regulations at 18 CFR §35.19a(a)(2)(iii) from the date payment was made by Interconnection Customer to the date such Transmission Owner refunds such payment to Interconnection Customer, and

(iii) with respect to any such taxes paid by such Transmission Owner, any refund or credit such Transmission Owner receives or to which it may be entitled from any Governmental Authority, interest (or that portion thereof attributable to the payment described in clause (i), above) owed to such Transmission Owner for such overpayment of taxes (including any reduction in interest otherwise payable by such Transmission Owner to any Governmental Authority resulting from an offset or credit); provided, however, that such Transmission Owner will remit such amount promptly to Interconnection Customer only after and to the extent that such Transmission Owner has received a tax refund, credit or offset from any Governmental Authority for any applicable overpayment of income tax related to such Transmission Owner's Interconnection Facilities.

The intent of this provision is to leave the Parties, to the extent practicable, in the event that no taxes are due with respect to any payment for Transmission Owners' Interconnection Facilities and Network Upgrades hereunder, in the same position they would have been in had no such tax payments been made.

5.17.9 Taxes Other Than Income Taxes. Upon the timely request by Interconnection Customer, and at Interconnection Customer's sole expense, Transmission Owner or the CAISO may appeal, protest, seek abatement of, or otherwise contest any tax (other than federal or state income tax) asserted or assessed against Transmission Owner or the CAISO for which Interconnection Customer may be required to reimburse Transmission Owner or the CAISO under the terms of this Agreement. Interconnection Customer shall pay to Transmission Owner on a periodic basis, as invoiced by Transmission Owner, Transmission Owners' documented reasonable costs of prosecuting such appeal, protest, abatement, or other contest. Interconnection Customer, Transmission Owner and the CAISO if applicable, shall cooperate in good faith with respect to any such contest. Unless the payment of such taxes is a prerequisite to an appeal or abatement or cannot be deferred, no amount shall be payable by Interconnection Customer to Transmission Owner or the CAISO for such taxes until they are assessed by a final, non-appealable order by any court or agency of competent jurisdiction. In the event that a tax payment is withheld and ultimately due and payable after

appeal, Interconnection Customer will be responsible for all taxes, interest and penalties, other than penalties attributable to any delay caused by Transmission Owner or the CAISO.

5.18 Tax Status. Each Party shall cooperate with the others to maintain the other Parties' tax status. Nothing in this Agreement is intended to adversely affect any Transmission Owner's or the CAISO's tax exempt status with respect to the issuance of bonds including, but not limited to, Local Furnishing Bonds.

5.19 Modification.

5.19.1 General. The Interconnection Customer or the Transmission Owners may undertake modifications to their respective facilities, subject to the provisions of this Agreement and any applicable provisions of any applicable Tariff. If either the Interconnection Customer on the one hand, or Transmission Owners on the other hand, plan to undertake a modification that reasonably may be expected to affect the other's facilities, the Party planning the modification shall provide to the other Parties sufficient information regarding such modification so that the other Parties may evaluate the potential impact of such modification prior to commencement of the work or implementation of the modification. Such information shall be deemed to be confidential hereunder and shall include information concerning the timing of such modifications and whether such modifications are expected to interrupt the flow of electricity from the Large Generating Facility. The Party desiring to perform such work or implement the modification shall provide the relevant drawings, plans, and specifications to the other Parties at least ninety (90) Calendar Days in advance of the commencement of the work or implementation of the modification or such shorter period upon which the Parties may agree, which agreement shall not unreasonably be withheld, conditioned or delayed.

In the case of Large Generating Facility modifications that do not require Interconnection Customer to submit an Interconnection Request, Transmission Owners and the CAISO shall provide, within thirty (30) Calendar Days (or such other time as the Parties may agree), an estimate of any additional modifications to the Transmission Systems, Transmission Owners' Interconnection Facilities or Network Upgrades necessitated by such Interconnection Customer modification and a good faith estimate of the costs thereof. The Transmission Owners and the CAISO shall each determine if a Large Generating Facility modification is a Material Modification in accordance with their respective Large Generator Interconnection Procedures.

Notwithstanding anything in this Agreement to the contrary, any modification to the Large Generating Facility or the terms upon which Interconnection Service is provided hereunder that requires additional facilities beyond or in lieu of those facilities specifically identified in Appendices A-1, A-2, and A-3, including but not limited to additional Transmission Owners' Interconnection Facilities or Network Upgrades, shall be dealt with in a separate Large Generator Interconnection Agreement or in an amendment to this Agreement agreed to by all Parties; provided, however, that to the extent IID determines the modification

requires additional non-JPP facilities owned by IID, such change may be dealt with in a separate Affected System Study Agreement and/or Affected System Construction and Operation Agreement.

5.19.2 Standards. Any additions, modifications, or replacements made to the Transmission Systems or Transmission Owners' Interconnection Facilities that may reasonably be expected to affect the Generating Facility or Interconnection Facilities shall be designed, constructed and operated in accordance with this Agreement, Applicable Reliability Standards, and Good Utility Practice. Any additions, modifications, or replacements made to the Generating Facility or Interconnection Customer's Interconnection Facilities that may reasonably be expected to affect the Transmission Systems or Transmission Owners' Interconnection Facilities shall be designed, constructed and operated in accordance with this Agreement, Applicable Reliability Standards, and Good Utility Practice.

5.19.3 Modification Costs. Interconnection Customer shall not be directly assigned for the costs of any additions, modifications, or replacements that Transmission Owners make to Transmission Owners' Interconnection Facilities or to each respective Transmission Owner's Transmission System to facilitate the interconnection of a third party to Transmission Owners' Interconnection Facilities or the applicable Transmission Owner's Transmission System, or to provide transmission service to a third party under the applicable Tariff, *i.e.*, APS, IID and the CAISO. Interconnection Customer shall be responsible for the costs of any additions, modifications, or replacements to Interconnection Facilities that may be necessary to maintain or upgrade such Interconnection Facilities consistent with Applicable Laws and Regulations, Applicable Reliability Standards or Good Utility Practice.

Article 6. Testing and Inspection

6.1 Pre-Commercial Operation Date Testing and Modifications. Prior to the Commercial Operation Date, APS, on behalf of Transmission Owners, shall test Transmission Owners' Interconnection Facilities and Network Upgrades to the JPP in Appendices A-1 and A-2, and SDG&E shall test Network Upgrades to its non-JPP facilities in Appendix A-3. To the extent that the Affected System Study performed by IID identifies the need to install or construct any Network Upgrades to non-JPP facilities owned by IID, then IID shall test such Network Upgrades to non-JPP facilities prior to the Commercial Operation Date and Interconnection Customer shall test the Large Generating Facility and Interconnection Customer's Interconnection Facilities to ensure their safe and reliable operation. Similar testing may be required after initial operation. APS, on behalf of Transmission Owners, SDG&E, IID, and the Interconnection Customer shall make any modifications to their respective facilities that are found to be necessary as a result of such testing. The Interconnection Customer shall bear the cost of all such testing and modifications. The Interconnection Customer shall not commence initial parallel operation of the first Project Block for Phase A of the Generating Facility or the first Project Block of Phase B of the Generating Facility with the Transmission System until the Transmission Owners provide prior written approval, which shall not be unreasonably withheld, for operation of such Project Phase. Interconnection Customer shall generate

test energy at the Large Generating Facility only if it has arranged for the delivery of such test energy.

- 6.2 Post-Commercial Operation Date Testing and Modifications.** As between Transmission Owners for the JPP facilities in Appendices A-1 and A-2, SDG&E for its non-JPP facilities in Appendix A-3, and IID for its non-JPP facilities, if any are identified in the Affected System Study, respectively, and Interconnection Customer, each Party shall at its own expense perform routine inspection and testing of its facilities and equipment in accordance with Good Utility Practice as may be necessary to ensure the continued interconnection of the Large Generating Facility with the JPP in a safe and reliable manner. As between Transmission Owners for the JPP facilities in Appendices A-1 and A-2, SDG&E for its non-JPP facilities in Appendix A-3, and IID for its non-JPP facilities, if any are identified in the Affected System Study, respectively, and Interconnection Customer, each Party shall have the right, upon advance written notice, to require reasonable additional testing of the other Party's facilities, at the requesting Party's expense, as may be in accordance with Good Utility Practice.
- 6.3 Right to Observe Testing.** Each Party shall notify the other Parties at least fourteen (14) Calendar Days in advance of its performance of tests of its Interconnection Facilities or Generating Facility. The other Parties have the right, at their own expense, to observe such testing.
- 6.4 Right to Inspect.** Each Party shall have the right, but shall have no obligation to: (i) observe another Party's tests and/or inspection of any of its System Protection Facilities and other protective equipment, including Power System Stabilizers; (ii) review the settings of another Party's System Protection Facilities and other protective equipment; and (iii) review another Party's maintenance records relative to the Interconnection Facilities, the System Protection Facilities and other protective equipment. A Party may exercise these rights from time to time as it deems necessary upon reasonable notice to the other Party. The exercise or non-exercise by a Party of any such rights shall not be construed as an endorsement or confirmation of any element or condition of the Interconnection Facilities or the System Protection Facilities or other protective equipment or the operation thereof, or as a warranty as to the fitness, safety, desirability, or reliability of same. Any information that a Party obtains through the exercise of any of its rights under this Article 6.4 shall be deemed to be Confidential Information and treated pursuant to Article 22 of this Agreement.

Article 7. Metering

- 7.1 General.** Each Party shall comply with any Applicable Reliability Standards and the Applicable Reliability Council requirements. Unless otherwise agreed by the Parties, APS, on behalf of Transmission Owners, shall install Metering Equipment at the Point of Interconnection prior to any operation of the Large Generating Facility and shall own, operate, test and maintain such Metering Equipment. Power flows to and from the Large Generating Facility shall be measured at or, at Transmission Owners' option, compensated to, the Point of Interconnection. APS, on behalf of Transmission Owners, shall provide metering quantities, in analog and/or digital form, to Interconnection Customer upon request. Interconnection Customer shall bear all reasonable documented costs associated with the purchase, installation, operation, testing and maintenance of the Metering Equipment.

- 7.2 Check Meters.** Interconnection Customer, at its option and expense, may install and operate, on its premises and on its side of the Point of Interconnection, one or more check meters to check Transmission Owners' meters. Such check meters shall be for check purposes only and shall not be used for the measurement of power flows for purposes of this Agreement, except as provided in Article 7.4 below. The check meters shall be subject at all reasonable times to inspection and examination by APS, on behalf of Transmission Owners, or its designee. The installation, operation and maintenance thereof shall be performed entirely by Interconnection Customer in accordance with Good Utility Practice.
- 7.3 Standards.** APS, on behalf of Transmission Owners, shall install, calibrate, and test revenue quality Metering Equipment in accordance with applicable ANSI standards.
- 7.4 Testing of Metering Equipment.** APS, on behalf of Transmission Owners, shall inspect and test all Transmission Owner Metering Equipment for the JPP upon installation and at least once every two (2) years thereafter. If requested to do so by Interconnection Customer, APS, on behalf of Transmission Owners, shall, at Interconnection Customer's expense, inspect or test such Metering Equipment more frequently than every two (2) years. APS, on behalf of Transmission Owners, shall give reasonable notice of the time when any inspection or test shall take place, and Interconnection Customer may have representatives present at the test or inspection. If at any time Metering Equipment is found to be inaccurate or defective, it shall be adjusted, repaired or replaced at Interconnection Customer's expense, in order to provide accurate metering, unless the inaccuracy or defect is due to Transmission Owners' failure to maintain, then Transmission Owners shall pay. If Metering Equipment fails to register, or if the measurement made by Metering Equipment during a test varies by more than two percent from the measurement made by the standard meter used in the test, APS, on behalf of Transmission Owners, shall adjust the measurements by correcting all measurements for the period during which Metering Equipment was in error by using Interconnection Customer's check meters, if installed. If no such check meters are installed or if the period cannot be reasonably ascertained, the adjustment shall be for the period immediately preceding the test of the Metering Equipment equal to one-half the time from the date of the last previous test of the Metering Equipment.
- 7.5 Metering Data.** At Interconnection Customer's expense, the metered data shall be telemetered to one or more locations designated by Transmission Owners and one or more locations designated by Interconnection Customer. Subject to Article 7.6, such telemetered data shall be used, under normal operating conditions, as the official measurement of the amount of energy delivered from the Large Generating Facility to the Point of Interconnection.
- 7.6 Metering Requirements of CAISO.** Notwithstanding the other provisions of Article 7, if the Interconnection Customer elects the CAISO as the Balancing Authority for a Project Phase, the Interconnection Customer shall also comply with the metering requirements of the CAISO Tariff for such Phase, including installation of Metering Equipment in compliance with the requirements of the CAISO Tariff. For Phase A of the Generating Facility the Interconnection Customer has selected the CAISO as the Balancing Authority, so for Phase A of the Generating Facility, in addition to the requirements of this Article 7, the Interconnection Customer shall also comply with the

metering requirements of the CAISO Tariff. If the Interconnection Customer elects the CAISO as the Balancing Authority for Phase B of the Generating Facility pursuant to Article 9.2 of this Agreement, the Interconnection Customer shall also comply with the requirements of this Article 7 and the metering requirements of the CAISO Tariff for Phase B of the Generating Facility. Notwithstanding the provisions of Article 7.5, for any Project Phase in the CAISO Balancing Authority Area, data from the CAISO-compliant metering shall be used, under normal operating conditions, as the official measurement of the amount of energy delivered from the Large Generating Facility to the Point of Interconnection. Any Metering Equipment installed by APS on behalf of the Transmission Owners will serve as an alternative source for meter data for the CAISO in the event of failure of the CAISO-compliant metering to provide accurate meter data.

Article 8. Communications

8.1 Interconnection Customer Obligations. Interconnection Customer shall maintain satisfactory operating communications with APS's Transmission System dispatcher or representative designated by APS, and with CAISO, to the extent CAISO is selected by Interconnection Customer as Balancing Authority for a Project Phase. Interconnection Customer shall provide standard voice line, dedicated voice line and facsimile communications at its Large Generating Facility control room or central dispatch facility through use of either the public telephone system, or a voice communications system that does not rely on the public telephone system. Interconnection Customer shall also provide the dedicated data circuit(s) necessary to provide Interconnection Customer data to APS, on behalf of Transmission Owners as set forth in Appendix D, Security Arrangements Details, and as applicable, to CAISO. The data circuit(s) shall extend from the Large Generating Facility to the location(s) specified by APS, on behalf of Transmission Owners, and the CAISO. Any required maintenance of such communications equipment shall be performed by Interconnection Customer. Operational communications shall be activated and maintained under, but not be limited to, the following events: system paralleling or separation, scheduled and unscheduled shutdowns, equipment clearances, and hourly and daily load data.

8.2 Remote Terminal Unit. Prior to the Initial Synchronization Date of any Project Phase, a Remote Terminal Unit, or equivalent data collection and transfer equipment acceptable to the Parties, shall be installed by Interconnection Customer, or by APS, on behalf of Transmission Owners, at Interconnection Customer's expense, to gather accumulated and instantaneous data to be telemetered to the location(s) designated by APS, on behalf of Transmission Owners, through use of a dedicated point-to-point data circuit(s) as indicated in Article 8.1. The communication protocol for the data circuit(s) shall be specified by APS, on behalf of Transmission Owners. Instantaneous bi-directional analog real power and reactive power flow information must be telemetered directly to the location(s) specified by APS.

As among APS, on behalf of Transmission Owners, CAISO and Interconnection Customer, each such Party will promptly advise the other Parties if it detects or otherwise learns of any metering, telemetry or communications equipment errors or malfunctions that require the attention and/or correction by the other Parties. The Party owning such equipment shall correct such error or malfunction as soon as reasonably feasible.

- 8.3 No Annexation.** Any and all equipment placed on the premises of a Party shall be and remain the property of the Party providing such equipment regardless of the mode and manner of annexation or attachment to real property, unless otherwise mutually agreed by the Parties.
- 8.4 Communication Requirements of CAISO.** Notwithstanding the other provisions of Article 8, if the Interconnection Customer elects the CAISO as the Balancing Authority for a Project Phase, the Interconnection Customer shall also comply with the communications requirements of the CAISO Tariff. For Phase A of the Generating Facility the Interconnection Customer has selected the CAISO as the Balancing Authority, so for Phase A of the Generating Facility, in addition to the requirements of this Article 8, the Interconnection Customer shall also comply with the communications requirements of the CAISO Tariff. If the Interconnection Customer elects the CAISO as the Balancing Authority for Phase B of the Generating Facility pursuant to Article 9.2 of this Agreement, the Interconnection Customer shall also comply with the requirements of this Article 8 and the communications requirements of the CAISO Tariff for Phase B of the Generating Facility.

Article 9. Operations

- 9.1 General.** Each Party shall comply with Applicable Reliability Standards and the Applicable Reliability Council requirements. Each Party shall provide to the other Parties all information that may reasonably be required by the other Parties to comply with Applicable Laws and Regulations and Applicable Reliability Standards.
- 9.2 Balancing Authority Area Notification.** At least three months before Initial Synchronization Date of a Project Phase, Interconnection Customer shall notify APS and the CAISO in writing of the Balancing Authority Area in which that Project Phase will be located, if and as permitted by the relevant transmission tariffs, including the APS and CAISO Tariffs. All necessary arrangements, including but not limited to those set forth in Articles 7 and 8 of this Agreement, and remote Balancing Authority Area generator interchange agreements, if applicable, and the appropriate measures under such agreements, shall be executed and implemented prior to the placement a Project Phase in the designated Balancing Authority Area. Separate notifications will be required for each Project Phase, as specified in Appendix C.
- 9.3 Transmission Owner and CAISO Obligations.** The Transmission Owners and the CAISO shall cause their respective Transmission Systems and APS, on behalf of Transmission Owners, shall cause the Transmission Owners' Interconnection Facilities to be operated, maintained and controlled in a safe and reliable manner and in accordance with this Agreement. APS and the CAISO may provide operating instructions to Interconnection Customer consistent with this Agreement and APS's or the CAISO's operating protocols and procedures as they may change from time to time. APS and the CAISO will consider changes to their respective operating protocols and procedures proposed by Interconnection Customer.
- 9.4 Interconnection Customer Obligations.** Interconnection Customer shall at its own expense operate, maintain and control the Large Generating Facility and Interconnection Customer's Interconnection Facilities in a safe and reliable manner and in accordance with this Agreement. Interconnection Customer shall operate the Large Generating

Facility and Interconnection Customer's Interconnection Facilities in accordance with all applicable requirements of the Balancing Authority Area of which it is part, as such requirements are set forth in Appendix C, Interconnection Details, of this Agreement. Appendix C, Interconnection Details, will be modified to reflect changes to the requirements as they may change from time to time. A Party may request that the other Parties provide copies of the requirements set forth in Appendix C, Interconnection Details, of this Agreement.

9.5 Start-Up and Synchronization. Consistent with the Parties' mutually acceptable procedures, Interconnection Customer is responsible for the proper synchronization of the Large Generating Facility to the JPP.

9.6 Reactive Power.

9.6.1 Power Factor Design Criteria. Interconnection Customer shall design Phase A of the Large Generating Facility to maintain a composite power delivery at continuous rated power output at the Point of Interconnection at a power factor within the range of 0.95 leading to 0.95 lagging, which power factor range shall supersede any otherwise applicable power factor range set forth in the CAISO Tariff. The Interconnection Customer shall design Phase B of the Large Generating Facility to maintain a composite power delivery at continuous rated power output at the Point of Interconnection at a power factor within the range of 0.95 leading to 0.95 lagging or the Applicable Reliability Standard in effect at the time the Interconnection Studies for Phase B of the Generating Facility are performed. For Phase B of the Generating Facility, the Interconnection Studies for that Project Phase demonstrate or shall demonstrate that that Project Phase complies with Article 9.6.1 before Phase B of the Interconnection Project commences Trial Operation.

9.6.2 Voltage Schedules. APS shall be responsible for compliance with Applicable Reliability Standards related to reactive power and voltage schedules for the interconnection of the Large Generating Facility to the JPP, subject to any agreement entered into by APS and the CAISO regarding the allocation of responsibilities for compliance with Applicable Reliability Standards. Pursuant to that responsibility, once Interconnection Customer has synchronized the Large Generating Facility with the JPP, APS shall require Interconnection Customer to operate the Large Generating Facility to produce or absorb reactive power within the design limitations of the Large Generating Facility set forth in Article 9.6.1 (Power Factor Design Criteria), Appendix C, and the Interconnection Customer's data, as revised, that were provided for the Interconnection Studies. Voltage schedules required by APS shall treat all sources of reactive power interconnected to the JPP in an equitable and not unduly discriminatory manner. APS shall exercise Reasonable Efforts to provide Interconnection Customer with such schedules at least one (1) day in advance, and may make changes to such schedules as necessary to maintain the reliability of the Transmission Systems. Interconnection Customer shall operate the Large Generating Facility to maintain the specified output voltage or power factor at the Point of Interconnection within the design limitations of the Large Generating Facility set forth in Article 9.6.1 (Power Factor Design Criteria), and the Interconnection Customer's data, as revised, that were provided for the Interconnection Studies. If Interconnection

Customer is unable to maintain the specified voltage or power factor, it shall promptly notify the APS system operator.

9.6.2.1 Governors and Regulators. To the extent required by Applicable Reliability Standards, the Interconnection Customer shall procure, install, and maintain governors and regulators. To the extent required by Applicable Reliability Standards, whenever the Large Generating Facility is operated in parallel with the Transmission System and the speed governors (if installed on the generating unit pursuant to Good Utility Practice) and voltage regulators are capable of operation, Interconnection Customer shall operate the Large Generating Facility with its speed governors and voltage regulators in automatic operation. If the Large Generating Facility's speed governors and voltage regulators are not capable of such automatic operation, Interconnection Customer shall immediately notify APS and the CAISO and ensure that such Large Generating Facility operates as specified in Article 9.6.2 through manual operation and that its reactive power production or absorption (measured in MVARs) are within the design capability of the Large Generating Facility's generating unit(s) and steady state stability limits. The Interconnection Customer shall restore the speed governors and voltage regulators to automatic operation as soon as possible. If the Large Generating Facility's speed governors and voltage regulators are improperly tuned or malfunctioning, APS or the CAISO shall have the right to order the reduction in output or disconnection of the Large Generating Facility if the reliability of the Transmission System would be adversely affected. Interconnection Customer shall not cause its Large Generating Facility to disconnect automatically or instantaneously from the Transmission System or trip any generating unit comprising the Large Generating Facility for an under or over frequency condition unless the abnormal frequency condition persists for a time period beyond the limits set forth in ANSI/IEEE Standard C37.106, or such other standard as applied to other generators interconnecting to the JPP on a comparable basis.

9.6.3 Payment for Reactive Power. APS is required to pay Interconnection Customer for reactive power that Interconnection Customer provides or absorbs from the Large Generating Facility when APS requests Interconnection Customer to operate its Large Generating Facility outside the range specified in Article 9.6.1, provided that if APS pays its own or affiliated generators for reactive power service within the specified range, it must also pay Interconnection Customer. Payments shall be pursuant to Article 11.6 or such other agreement to which the Parties have otherwise agreed.

9.7 Outages and Interruptions.

9.7.1 Outages.

9.7.1.1 Outage Authority and Coordination. Each Party may in accordance with Good Utility Practice in coordination with the other Parties remove from service any of its respective Interconnection Facilities or Network

Upgrades that may impact the other Parties' facilities as necessary to perform maintenance or testing or to install or replace equipment, provided that the Interconnection Customer shall also coordinate outages of the Generating Facility with the CAISO pursuant to the provisions of the CAISO Tariff for each Project Phase that is within the CAISO Balancing Authority Area, and APS shall coordinate outages of the JPP and Transmission Owner Interconnection Facilities with the CAISO in accordance with agreed procedures. Absent an Emergency Condition, the Party scheduling a removal of such facility(ies) from service will use Reasonable Efforts to schedule such removal on a date and time mutually acceptable to the Parties. In all circumstances, any Party planning to remove such facility(ies) from service shall use Reasonable Efforts to minimize the effect on the other Party of such removal.

9.7.1.2 Outage Schedules. APS, IID and CAISO shall post scheduled outages of their respective transmission facilities in accordance with applicable Tariff requirements. Interconnection Customer shall submit its planned maintenance schedules for the Large Generating Facility to APS for a minimum of a rolling twenty-four month period and to the CAISO in accordance with the CAISO Tariff for any Project Phase in the CAISO Balancing Authority Area. Interconnection Customer shall update its planned maintenance schedules as necessary, including providing updates to the CAISO in accordance with the CAISO Tariff. APS, on behalf of Transmission Owners, and the CAISO, in accordance with the applicable provisions of the CAISO Tariff, may request Interconnection Customer to reschedule its maintenance as necessary to maintain the reliability of Transmission Owners' and the CAISO Transmission Systems; provided, however, adequacy of generation supply shall not be a criterion in determining Transmission System reliability, subject to Section 9 of the CAISO Tariff. APS shall compensate Interconnection Customer for any additional direct costs that Interconnection Customer incurs as a result of having to reschedule maintenance, including any additional overtime, breaking of maintenance contracts or other costs above and beyond the cost Interconnection Customer would have incurred absent APS's request to reschedule maintenance. The CAISO shall compensate Interconnection Customer for any additional direct costs that Interconnection Customer incurs as a result of having to reschedule maintenance in accordance with the CAISO Tariff. Interconnection Customer will not be eligible to receive compensation, if during the twelve (12) months prior to the date of the scheduled maintenance, Interconnection Customer had modified its schedule of maintenance activities.

9.7.1.3 Outage Restoration. If an outage on a Party's Interconnection Facilities or Network Upgrades adversely affects another Party's operations or facilities, the Party that owns or controls the facility that is out of service shall use Reasonable Efforts to promptly restore such facility(ies) to a normal operating condition consistent with the nature of the outage. The Party that owns or controls the facility that is out of service shall provide the other Parties, to the extent such information is known, information on

the nature of the Emergency Condition, if the outage is caused by an Emergency Condition, an estimated time of restoration, and any corrective actions required. Initial verbal notice shall be followed up as soon as practicable with written notice explaining the nature of the outage, if requested by a Party, which may be provided by e-mail or facsimile.

9.7.2 Interruption of Service. If required by Good Utility Practice to do so, APS, on behalf of the Transmission Owners, may require Interconnection Customer to interrupt or reduce deliveries of electricity if such delivery of electricity could adversely affect the ability of APS to perform such activities as are necessary to safely and reliably operate and maintain the Transmission System. If the Interconnection Customer elects the CAISO as the Balancing Authority for a Project Phase, the CAISO may also have authority to require Interconnection Customer to curtail or interrupt such generation in accordance with the procedures established for generators in the CAISO Balancing Authority Area, in which case the procedures established by the CAISO pursuant to the CAISO Tariff shall apply in lieu of the provisions of this Article 9.7.2. APS or the CAISO shall notify the other as soon as possible of any curtailment, interruption, or reduction of deliveries from the Large Generating Facility that it may require. The following provisions shall apply to any interruption or reduction by APS permitted under this Article 9.7.2:

- 9.7.2.1** The interruption or reduction shall continue only for so long as reasonably necessary under Good Utility Practice;
- 9.7.2.2** Any such interruption or reduction shall be made on an equitable, non-discriminatory basis with respect to all generating facilities directly connected to its Transmission System;
- 9.7.2.3** When the interruption or reduction must be made under circumstances which do not allow for advance notice, APS shall notify Interconnection Customer by telephone as soon as practicable of the reasons for the curtailment, interruption, or reduction, and, if known, its expected duration. Telephone notification shall be followed by written notification, if requested by the Interconnection Customer, as soon as practicable;
- 9.7.2.4** Except during the existence of an Emergency Condition, when the interruption or reduction can be scheduled without advance notice, APS shall notify Interconnection Customer in advance regarding the timing of such scheduling and further notify Interconnection Customer of the expected duration. APS shall coordinate with Interconnection Customer using Good Utility Practice to schedule the interruption or reduction during periods of least impact to Interconnection Customer, and APS, acting on behalf of the Transmission Owners;
- 9.7.2.5** The Parties shall cooperate and coordinate with each other to the extent necessary in order to restore the Large Generating Facility, Interconnection Facilities, and their Transmission Systems to their

normal operating state, consistent with system conditions and Good Utility Practice.

9.7.3 Under-Frequency and Over Frequency Conditions. The Transmission System is designed to automatically activate a load-shed program as required by Applicable Reliability Standards and the Applicable Reliability Council in the event of an under-frequency system disturbance. Interconnection Customer shall implement under-frequency and over-frequency protection set points for the Large Generating Facility as required by the Applicable Reliability Standards and Applicable Reliability Council to ensure “ride through” capability of the Transmission System. Large Generating Facility response to frequency deviations of pre-determined magnitudes, both under-frequency and over-frequency deviations, shall be studied and coordinated with APS and the CAISO in accordance with Good Utility Practice. The term “ride through” as used herein shall mean the ability of a Generating Facility to stay connected to and synchronized with the Transmission System during system disturbances within a range of under-frequency and over-frequency conditions, in accordance with Good Utility Practice.

9.7.4 System Protection and Other Control Requirements.

9.7.4.1 System Protection Facilities. Interconnection Customer shall, at its expense, install, operate and maintain System Protection Facilities as a part of the Large Generating Facility or Interconnection Customer’s Interconnection Facilities. Transmission Owners shall install at Interconnection Customer’s expense any System Protection Facilities that may be required on Transmission Owners’ Interconnection Facilities and their Transmission Systems as a result of the interconnection of the Large Generating Facility and Interconnection Customer’s Interconnection Facilities.

9.7.4.2 The Transmission Owners’ and Interconnection Customer’s protection facilities shall be designed and coordinated with other systems in accordance with Applicable Reliability Standards, Applicable Reliability Council criteria and Good Utility Practice.

9.7.4.3 The Transmission Owners and Interconnection Customer shall be responsible for protection of their respective facilities consistent with Good Utility Practice.

9.7.4.4 The Transmission Owners’ and Interconnection Customer’s protective relay design shall incorporate the necessary test switches to perform the tests required in Article 6. The required test switches will be placed such that they allow operation of lockout relays while preventing breaker failure schemes from operating and causing unnecessary breaker operations and/or the tripping of Interconnection Customer’s units.

9.7.4.5 The Transmission Owners and Interconnection Customer will cause to be tested, operated and maintained System Protection Facilities in accordance with Good Utility Practice.

9.7.4.6 Prior to the in-service date, and again prior to the Commercial Operation Date, the Transmission Owners and Interconnection Customer or their respective agents shall perform a complete calibration test and functional trip test of the System Protection Facilities. At intervals suggested by Good Utility Practice and following any apparent malfunction of the System Protection Facilities, the Transmission Owners and Interconnection Customer shall perform both calibration and functional trip tests of their respective System Protection Facilities. These tests do not require the tripping of any in-service generation unit. These tests do, however, require that all protective relays and lockout contacts be activated.

9.7.5 Requirements for Protection. In compliance with Good Utility Practice, Interconnection Customer shall provide, install, own, and maintain relays, circuit breakers and all other devices necessary to remove any fault contribution of the Large Generating Facility to any short circuit occurring on the Transmission System not otherwise isolated by Transmission Owners' respective equipment, such that the removal of the fault contribution shall be coordinated with the protective requirements of the Transmission System. Such protective equipment shall include, without limitation, a disconnecting device or switch with fault current-interrupting capability located between the Large Generating Facility and the JPP at a site selected upon mutual agreement (not to be unreasonably withheld, conditioned or delayed) of the Parties. Interconnection Customer shall be responsible for protection of the Large Generating Facility and Interconnection Customer's other equipment from such conditions as negative sequence currents, over- or under-frequency, sudden load rejection, over- or under-voltage, and generator loss-of-field. Interconnection Customer shall be solely responsible to disconnect the Large Generating Facility and Interconnection Customer's other equipment if conditions on the Transmission System could adversely affect the Large Generating Facility.

9.7.6 Power Quality. Neither Party's facilities shall cause excessive voltage flicker nor introduce excessive distortion to the sinusoidal voltage or current waves as defined by ANSI Standard C84.1-1989, in accordance with IEEE Standard 519, or any applicable superseding electric industry standard or Applicable Reliability Standard. In the event of a conflict among ANSI Standard C84.1-1989, any applicable superseding electric industry standard or Applicable Reliability Standard, the Applicable Reliability Standard shall control.

9.8 Switching and Tagging Rules. APS, on behalf of Transmission Owners, and the Interconnection Customer shall provide each other a copy of its switching and tagging rules that are applicable to the other's activities. Such switching and tagging rules shall be developed on a non-discriminatory basis. APS, on behalf of Transmission Owners, and Interconnection Customer shall comply with applicable switching and tagging rules, as amended from time to time, in obtaining clearances for work or for switching operations on equipment.

9.9 Use of Interconnection Facilities by Third Parties.

- 9.9.1 Purpose of Interconnection Facilities.** Except as may be required by Applicable Laws and Regulations, or as otherwise agreed to among the Parties, the Interconnection Facilities shall be constructed for the sole purpose of interconnecting the Large Generating Facility to the JPP and shall be used for no other purpose.
- 9.9.2 Third Party Users.** If required by Applicable Laws and Regulations or if the Parties mutually agree, such agreement not to be unreasonably withheld, to allow one or more third parties to use Transmission Owners' Interconnection Facilities, or any part thereof, Interconnection Customer will be entitled to compensation for the capital expenses it incurred in connection with the Interconnection Facilities based upon the pro rata use of the Interconnection Facilities by each Transmission Owner, third party user, and Interconnection Customer, in accordance with Applicable Laws and Regulations or upon some other mutually-agreed upon methodology. In addition, cost responsibility for ongoing costs, including operation and maintenance costs associated with the Interconnection Facilities, will be allocated between Interconnection Customer and any third party users based upon the pro rata use of the Interconnection Facilities by each Transmission Owner, third party user, and Interconnection Customer, in accordance with Applicable Laws and Regulations or upon some other mutually agreed upon methodology. If the issue of such compensation or allocation cannot be resolved through such negotiations, it shall be submitted to arbitration pursuant to Article 27 of this Agreement or, if a complaint is made against a FERC jurisdictional public utility that is a Party to this Agreement, to FERC for resolution with respect to that FERC jurisdictional public utility.
- 9.10 Disturbance Analysis Data Exchange.** The Parties will cooperate with one another in the analysis of disturbances to either the Large Generating Facility or the Transmission Systems by gathering and providing access to any information relating to any disturbance, including information from oscillography, protective relay targets, breaker operations and sequence of events records, and any disturbance information required by Good Utility Practice.

Article 10. Maintenance

- 10.1 Transmission Owner Obligations.** Transmission Owners shall maintain the Transmission Owners' Transmission Systems and Transmission Owners' Interconnection Facilities in a safe and reliable manner and in accordance with this Agreement.
- 10.2 Interconnection Customer Obligations.** Interconnection Customer shall maintain the Large Generating Facility and Interconnection Customer's Interconnection Facilities in a safe and reliable manner and in accordance with this Agreement.
- 10.3 Coordination.** APS, on behalf of Transmission Owners, Interconnection Customer and the CAISO shall confer regularly to coordinate the planning, scheduling and performance of preventive and corrective maintenance on the Large Generating Facility and the Interconnection Facilities, which maintenance coordination shall be consistent with Article 9.7.1.

- 10.4 Secondary Systems.** APS, on behalf of Transmission Owners, Interconnection Customer and the CAISO shall cooperate with each other in the inspection, maintenance, and testing of control or power circuits that operate below 600 volts, AC or DC, including, but not limited to, any hardware, control or protective devices, cables, conductors, electric raceways, secondary equipment panels, transducers, batteries, chargers, and voltage and current transformers that directly affect the operation of such Parties' facilities and equipment which may reasonably be expected to impact the other Parties. APS, on behalf of Transmission Owners, Interconnection Customer and the CAISO shall provide advance notice to each other before undertaking any work on such circuits, especially on electrical circuits involving circuit breaker trip and close contacts, current transformers, or potential transformers.
- 10.5 Operating and Maintenance Expenses.** Subject to the provisions herein addressing the use of facilities by others, and except for operations and maintenance expenses associated with modifications made for providing interconnection or transmission service to a third party and such third party pays for such expenses, Interconnection Customer shall be responsible for all reasonable expenses including overheads, associated with: (1) owning, operating, maintaining, repairing, and replacing Interconnection Customer's Interconnection Facilities; and (2) operation, maintenance, repair and replacement of Transmission Owners' Interconnection Facilities.

Article 11. Performance Obligation

- 11.1 Interconnection Customer Interconnection Facilities.** Interconnection Customer shall design, procure, construct, install, own and/or control Interconnection Customer Interconnection Facilities described in Appendices A-1 and A-2 at its sole expense.
- 11.2 Transmission Owners' Interconnection Facilities.** APS, on behalf of Transmission Owners, shall design, procure, construct, install, own and/or control the Transmission Owners' Interconnection Facilities described in Appendices A-1 and A-2 at the sole expense of the Interconnection Customer.
- 11.3 Network Upgrades and Distribution Upgrades.** APS, on behalf of Transmission Owners shall design, procure, construct, and install, and the Transmission Owners shall jointly own the JPP Network Upgrades and Distribution Upgrades described in Appendices A-1 and A-2. SDG&E shall design, procure, construct, install, and own the non-JPP Network Upgrades described in Appendix A-3. Unless Transmission Owners, individually or collectively, elect to fund the capital for the Network Upgrades, they shall be solely funded by Interconnection Customer. For Network Upgrades to SDG&E's Transmission System, including SDG&E's share of the JPP, the amount of Interconnection Customer's cost responsibility to SDG&E shall be determined pursuant to the methodology set forth in Section 12.3.1 and Appendix 2 of the CAISO's Large Generator Interconnection Procedures.
- 11.4 Transmission Credits.**
- 11.4.1 Repayment of Amounts Advanced to APS for Network Upgrades to APS's Share of the JPP.** Interconnection Customer shall be entitled to a cash repayment from APS, equal to the total amount paid by Interconnection Customer to Transmission Owners for the Network Upgrades to the JPP

identified in Appendices A-1 and A-2, and not refunded to Interconnection Customer pursuant to Article 5.17.8 or otherwise, times APS's percentage Ownership Interest in the JPP ("APS's pro rata amount"), plus any tax gross-up or other tax-related payments associated with APS's pro rata amount, to be paid to Interconnection Customer on a dollar-for-dollar basis for the non-usage sensitive portion of transmission charges, as payments are made under APS's Tariff applicable to transmission services on APS's Transmission System with respect to the Large Generating Facility. Such repayment shall include interest calculated in accordance with the methodology set forth in FERC's regulations at 18 C.F.R. § 35.19a(a)(2)(iii) from the date of any payment for JPP Network Upgrades through the date on which the Interconnection Customer receives a repayment of such payment pursuant to this subparagraph. Interconnection Customer may assign such repayment rights to any person.

Notwithstanding the foregoing, Interconnection Customer and APS may adopt an alternative payment schedule that is mutually agreeable so long as APS takes one of the following actions no later than five years from the Commercial Operation Date for a Project Phase: (1) returns to Interconnection Customer any of its pro rata amounts advanced for JPP Network Upgrades not previously repaid, or (2) declares in writing that APS will continue to provide payments to Interconnection Customer on a dollar-for-dollar basis for the non-usage sensitive portion of transmission charges, or develop an alternative schedule that is mutually agreeable and provides for the return of all its pro rata amounts advanced for Network Upgrades not previously repaid; however, full reimbursement by APS of its pro rata amount shall not extend beyond twenty (20) years from the Commercial Operation Date for a Project Phase, and further, if this Agreement terminates within five (5) years from the Commercial Operation Date for that Project Phase, APS's obligation to pay refunds to the Interconnection Customer shall cease as of the date of termination.

If the Large Generating Facility fails to achieve Commercial Operation for a Project Phase, but it or another Generating Facility is later constructed and makes use of the Network Upgrades to the JPP associated with that Project Phase, APS shall at that time reimburse Interconnection Customer for APS's pro rata amount advanced to it for the JPP Network Upgrades for the Project Phase. Before any such reimbursement can occur, the Interconnection Customer, or the entity that ultimately constructs the Generating Facility, if different, is responsible for identifying and demonstrating to APS the entity to which reimbursement must be made in order to implement the intent of this reimbursement obligation.

11.4.2 Repayment of Amounts Advanced to SDG&E for Network Upgrades to Its Share of the JPP and to Its Non-JPP Facilities.

Upon the Commercial Operation Date for a Project Phase, the Interconnection Customer shall be entitled to a repayment, equal to the total amount paid by Interconnection Customer to SDG&E for the Network Upgrades to the JPP identified in Appendices A-1 and A-2, and not refunded to Interconnection Customer pursuant to Article 5.17.8 or otherwise, times SDG&E's percentage Ownership Interest in the JPP ("SDG&E's pro rata amount"), plus any amount paid to SDG&E for the costs of Network Upgrades to non-JPP facilities owned

by SDG&E set forth in Appendix A-3 and not refunded to Interconnection Customer pursuant to Article 5.17.8 or otherwise (“SDG&E’s individual amount”), plus any tax gross-up or other tax-related payments associated with Network Upgrades and not refunded to the Interconnection Customer pursuant to Article 5.17.8 or otherwise, and shall be paid to the Interconnection Customer by SDG&E on a dollar-for-dollar basis either through (1) direct payments made on a levelized basis over the five-year period commencing on the Commercial Operation Date for a Project Phase; or (2) any alternative payment schedule that is mutually agreeable to the Interconnection Customer and SDG&E, provided that such amount is paid within five (5) years from the Commercial Operation Date for a Project Phase. *See also* Appendices A-1 and A-2. Notwithstanding the foregoing, if this Agreement terminates within five (5) years from the Commercial Operation Date for that Project Phase, SDG&E’s obligation to pay refunds to the Interconnection Customer shall cease as of the date of termination. Any repayment shall include interest calculated in accordance with the methodology set forth in FERC’s regulations at 18 C.F.R. §35.19a(a)(2)(iii) from the date of any payment for Network Upgrades through the date on which the Interconnection Customer receives a repayment of such payment. Interest shall continue to accrue on the repayment obligation so long as this Agreement is in effect. The Interconnection Customer may assign such repayment rights to any person.

If the Large Generating Facility fails to achieve Commercial Operation for a Project Phase, but it or another Generating Facility is later constructed and makes use of the Network Upgrades associated with that Project Phase, SDG&E shall at that time reimburse Interconnection Customer for SDG&E’s pro rata amount and the individual amount advanced to SDG&E for the Network Upgrades for the Project Phase. Before any such reimbursement can occur, the Interconnection Customer, or the entity that ultimately constructs the Generating Facility, if different, is responsible for identifying and demonstrating to SDG&E the appropriate entity to which reimbursement must be made in order to implement the intent of this reimbursement obligation.

11.4.3 Repayment of Amounts Advanced to IID for Network Upgrades to IID’s Share of the JPP. The Parties acknowledge that IID is not a jurisdictional public utility subject to FERC’s rate jurisdiction under Section 205 or 206 of the Federal Power Act. The responsibility to provide transmission rate credits, under FERC’s generation interconnection regulations, therefore does not extend to IID. *See* Order No. 2003-C, 111 FERC ¶ 61,401, at P 18 (2005)(citing Order No. 2003, 104 FERC ¶ 61,103, at P 843 (2003)). Notwithstanding its non-jurisdictional status, IID hereby agrees to provide transmission rate credits to Interconnection Customer (or any other qualified person to whom Interconnection Customer assigns its rights to such transmission rate credits) when Point-to-Point Transmission Service is taken on IID’s share of the JPP as follows: IID shall provide such rate credits in an amount equal to the total amount paid by Interconnection Customer to Transmission Owners for the Network Upgrades to the JPP identified in Appendices A-1 and A-2 and not refunded to Interconnection Customer pursuant to Article 5.17.8 or otherwise, times IID’s percentage Ownership Interest in the JPP (“IID’s pro rata amount”). Such rate credits shall be provided by IID on a dollar-for-dollar basis for the non-

usage sensitive portion of IID's transmission charges (i.e., the demand charge for reserved capacity), as payments are made by Interconnection Customer (or any other qualified person to whom Interconnection Customer assigns its rights to transmission rate credits) to IID under IID's Open Access Transmission Tariff, for a period no longer than twenty (20) years from the Commercial Operation Date for a Project Phase. Notwithstanding the foregoing, if this Agreement terminates within five (5) years from the Commercial Operation Date for that Project Phase, IID's obligation to pay refunds to the Interconnection Customer shall cease as of the date of termination. IID also hereby agrees that Interconnection Customer may assign its rights to such transmission rate credits to any person which qualifies as an Eligible Customer for Point-to-Point Transmission Service under IID's Open Access Transmission Tariff.

If the Large Generating Facility fails to achieve Commercial Operation for a Project Phase, but it or another Generating Facility is later constructed and makes use of the Network Upgrades to the JPP associated with that Project Phase, IID shall reimburse Interconnection Customer for IID's pro rata amount advanced to it for the JPP Network Upgrades for the Project Phase, provided that IID receives payment of those amounts from the entity making use of the JPP Network Upgrades. Before any such reimbursement can occur, the Interconnection Customer, or the entity that ultimately constructs the Generating Facility, if different, is responsible for identifying and demonstrating to IID the appropriate entity to which reimbursement must be made in order to implement the intent of this reimbursement obligation.

11.4.4 Special Provisions for Affected Systems. Interconnection Customer and any Affected System Operator shall enter into a separate agreement that provides for the repayment of amounts advanced to such Affected System Operator for Network Upgrades. The agreement shall specify the terms governing payments to be made by Interconnection Customer to the Affected System Operator as well as the repayment by the Affected System Operator.

The Parties acknowledge that an Affected System Study must be performed by IID to analyze system impacts and identify the Network Upgrades, if any, that are required to IID's Transmission System, including its non-JPP facilities, to accommodate Interconnection Requests received by the CAISO from interconnection customers in the CAISO's Transition Cluster, as defined in the CAISO's LGIP, including the Interconnection Customer that is a Party to this Agreement. IID and Interconnection Customer have executed or will execute an Affected System Study Agreement for Phase A of the Generating Facility, whereby IID will perform and Interconnection Customer will pay the costs of an Affected System Study. The total costs will be pro rated to the extent IID performs the Affected System Study in a cluster for multiple generators seeking to interconnect to the CAISO controlled grid, with Interconnection Customer allocated a proportionate share of the total costs. Subject to the terms of a mutually-acceptable Non-Disclosure Agreement between the CAISO and IID, the CAISO shall provide to IID its applicable base case Interconnection Study data to assist IID in performing the Affected System Study.

The Parties acknowledge that there may be a need for an Affected System Study for Phase B of the Generating Facility, as provided for in Appendix C to this Agreement.

If an Affected System Study shows that Network Upgrades are required to IID's Transmission System, other than IID's share of the JPP, Interconnection Customer and IID agree that they shall enter into an Affected System Construction and Operation Agreement and that failure of the Interconnection Customer or IID to enter into such an agreement in accordance with the terms of this Article shall be considered a breach of this Agreement. The Interconnection Customer and IID agree that pursuant to the Affected System Construction and Operation Agreement: (1) Interconnection Customer shall fund the costs of constructing Network Upgrades reasonably attributable to Interconnection Customer; (2) IID shall use Reasonable Efforts to construct any Network Upgrades to IID's non-JPP facilities needed to accommodate Interconnection Customer's Interconnection Request to the CAISO on a schedule consistent with the provisions regarding testing in Article 6.1 of this Agreement; and (3) to the extent that the Interconnection Customer provides funding for any IID Network Upgrades identified in the Affected System Study, IID shall provide rate credits for the amount of such funding, which has not otherwise been refunded, applied on a dollar-for-dollar basis to the non-usage sensitive portion of IID's transmission charges (i.e., the demand charge for reserved capacity), as payments are made by Interconnection Customer (or any other qualified person to whom Interconnection Customer assigns its rights to transmission rate credits) under IID's Tariff, for a period no longer than twenty (20) years from the Commercial Operation Date for the Project Phase.

Any disputes between Interconnection Customer and IID regarding the Affected System Study Agreement or Affected System Construction and Operation Agreement shall be resolved pursuant to the dispute resolution procedures in Section 13.5 of the Generation Interconnection Procedures in IID's Tariff.

11.4.5 Notwithstanding any other provision of this Agreement, nothing herein shall be construed as relinquishing or foreclosing any rights, including but not limited to firm transmission rights, capacity rights, transmission congestion rights, "Congestion Revenue Rights" defined in and available pursuant to the terms of the CAISO Tariff, or transmission credits, that Interconnection Customer, shall be entitled to, now or in the future, under any other agreement or tariff as a result of, or otherwise associated with, the transmission capacity, if any, created by the Network Upgrades, including the right to obtain cash reimbursements, merchant transmission "Congestion Revenue Rights" in accordance with Section 36.11 of the CAISO Tariff, or transmission credits for transmission service that is not associated with the Large Generating Facility.

11.5 Provision of Security. With regard to SDG&E's share of costs to be incurred for Transmission Owners' Interconnection Facilities and Network Upgrades to the JPP identified in Appendices A-1 and A-2, and for SDG&E's costs of Network Upgrades identified in Appendix A-3, the Interconnection Customer shall provide (or cause to be provided) all necessary Interconnection Financial Security required under Section 9 of the CAISO's LGIP in a manner acceptable under Section 9 of the CAISO's LGIP.

Failure to satisfy the CAISO's LGIP's requirements for the provision of Interconnection Financial Security shall result in the Interconnection Request being deemed withdrawn and subject to CAISO LGIP Section 3.8.

With regard to APS and IID's shares of the costs to be incurred for Interconnection Facilities and Network Upgrades to the JPP identified in Appendices A-1 and A-2, at least thirty (30) Calendar Days prior to the commencement of the procurement, installation, or construction of Transmission Owners' Interconnection Facilities and JPP Network Upgrades, the Interconnection Customer shall provide (or cause to be provided) APS, on behalf of APS and IID, a guarantee, a surety bond, letter of credit or other form of security that is reasonably acceptable to APS and IID, and is consistent with the Uniform Commercial Code of the jurisdiction identified in Article 14.2.1. Such security for payment shall be in an amount sufficient to cover the costs for constructing, procuring and installing both APS and IID's shares of the Transmission Owners' Interconnection Facilities and JPP Network Upgrades set forth in Appendices A-1 and A-2, and shall be reduced on a dollar-for-dollar basis for payments made to APS, on behalf of APS and IID, for these purposes.

The Parties agree that APS, as the Operating Agent of the JPP under the Participation Agreement, and solely as agent for APS and IID, will accept delivery of the financial security required for the APS and IID shares of the Transmission Owners' Interconnection Facilities and Network Upgrades to the JPP set forth in Appendices A-1 and A-2, which the Interconnection Customer is required to provide (or cause to be provided) in accordance with the milestone schedule set forth in Appendices B-1 and B-2. APS's receipt of any such financial security will be solely as agent for APS and IID, and APS shall have no obligations to the Interconnection Customer with regard to such financial security other than any obligation it may have for the APS and IID shares of such financial security; APS shall have all obligations, if any, to the Interconnection Customer for the APS and IID shares of such financial security. If it becomes necessary for the Transmission Owners to enforce their financial security rights, APS shall do so, as Operating Agent of the JPP, on behalf of APS and IID in accordance with the procedures set forth in Appendices A-1 and A-2.

SDG&E shall hold the Interconnection Financial Security required for SDG&E's Ownership Share in accordance with the requirements of the CAISO Tariff, provided, however, that if it becomes necessary for the Transmission Owners to enforce their financial security rights, SDG&E shall do so in accordance with the CAISO Tariff and the procedures set forth in Appendices A-1 and A-2.

In addition to complying with all requirements of the CAISO's Large Generator Interconnection Procedures regarding Interconnection Financial Security for security provided to SDG&E:

11.5.1 Any guarantee provided to APS, on behalf of APS and IID, and/or SDG&E, as applicable, must be made by an entity that meets the creditworthiness requirements of APS and IID and/or SDG&E, as applicable, and contain terms and conditions that guarantee payment of any amount that may be due from Interconnection Customer, up to an agreed-to maximum amount.

11.5.2 Any letter of credit to APS, on behalf of APS and IID, and/or SDG&E, , as applicable, must be issued by a financial institution reasonably acceptable to APS and IID and/or SDG&E, as applicable, and must specify a reasonable expiration date.

11.5.3 Any surety bond to APS, on behalf of APS and IID, and/or SDG&E, as applicable, must be issued by an insurer reasonably acceptable to APS and IID and/or SDG&E, as applicable, and must specify a reasonable expiration date.

Security shall be provided separately for Phase A of the Interconnection Project and Phase B of the Interconnection Project. Failure of the Interconnection Customer to have any required financial security in place at any time shall constitute grounds for termination of this Agreement pursuant to Articles 2.3 and 17.1, provided, however, Interconnection Customer shall have only 5 (five) Business Days to cure such failure following notice of the default. In addition to the foregoing, the obligation of Transmission Owners to perform under this Agreement is suspended until such failure is cured.

11.6 Interconnection Customer Compensation. If a Transmission Owner or the CAISO requests or directs Interconnection Customer to provide a service pursuant to 13.5.1 of this Agreement, the Transmission Owner or the CAISO requesting service shall compensate Interconnection Customer in accordance with its Tariff.

11.6.1 Interconnection Customer Compensation for Actions During Emergency Condition. The Transmission Owner or the CAISO requesting the Interconnection Customer to provide service during an Emergency Condition shall compensate Interconnection Customer for its provision of real and reactive power and other Emergency Condition services that Interconnection Customer provides to support its Transmission System during an Emergency Condition in accordance with Article 11.6.

Article 12. Invoice

12.1 General Provisions. For purposes of this Article, as between APS, on behalf of Transmission Owners of the JPP, and Interconnection Customer, each such Party shall submit to the other Party, on a monthly basis, invoices of amounts due for the preceding month with respect to JPP facilities. As between SDG&E, as owner of certain non-JPP facilities under this Agreement, and Interconnection Customer, each such Party shall submit to the other Party, on a monthly basis, invoices of amounts due for the preceding month for such non-JPP facilities owned solely by SDG&E.

Each invoice shall state the month to which the invoice applies and fully describe the services and equipment provided. The Parties may discharge mutual debts and payment obligations due and owing to each other on the same date through netting, in which case all amounts a Party owes to the other Party under this Agreement, including interest payments or credits, shall be netted so that only the net amount remaining due shall be paid by the owing Party; provided, however, that the Parties shall not net amounts relating to JPP facilities with those related to non-JPP facilities. Notwithstanding the foregoing, any invoices between the CAISO and another Party pursuant to the CAISO Tariff shall be submitted and paid in accordance with the CAISO Tariff.

Invoices shall be provided separately for Phase A of the Interconnection Project and Phase B of the Interconnection Project.

- 12.2 Final Invoice.** Within six months after completion of the construction of Transmission Owners' Interconnection Facilities and the Network Upgrades to the JPP for Phase A of the Interconnection Project and Phase B of the Interconnection Project, APS, on behalf of Transmission Owners, with respect to the Transmission Owners' Interconnection Facilities and JPP Network Upgrades identified in Appendices A-1 and A-2 and SDG&E with respect to its non-JPP Network Upgrades identified in Appendix A-3, shall each provide an invoice of the final cost of the construction of their respective Transmission Owners' Interconnection Facilities and the Network Upgrades and shall set forth such costs in sufficient detail to enable Interconnection Customer to compare the actual costs with the estimates and to ascertain deviations, if any, from the cost estimates.

With respect to costs associated with the Transmission Owners' Interconnection Facilities and the JPP Network Upgrades, APS, on behalf of Transmission Owners, shall refund to Interconnection Customer any amount by which the actual payment by Interconnection Customer for the estimated costs of such facilities exceeds the actual costs of construction within thirty (30) Calendar Days of the issuance of such final construction invoice; or, in the event the actual costs of construction exceed the Interconnection Customer's actual payment for estimated costs, then the Interconnection Customer shall pay to APS, on behalf of the Transmission Owners, any amount by which the actual costs of construction exceed the actual payment by the Interconnection Customer for the estimated costs within thirty (30) Calendar Days of the issuance of such final construction invoice.

With respect to costs associated with SDG&E's non-JPP Network Upgrades identified in Appendix A-3, SDG&E shall be responsible for refunding to the Interconnection Customer any amount by which the actual payment by the Interconnection Customer for estimated costs of such facilities exceeds the actual costs of construction, within thirty (30) Calendar Days of the issuance of such final construction invoice. In the event the actual costs of construction multiplied by the Interconnection Customer's percentage share of those costs exceed the Interconnection Customer's actual payment for estimated costs, then SDG&E shall be responsible for recovering such difference through its transmission service rates.

Invoices shall be provided separately for Phase A of the Interconnection Project and Phase B of the Interconnection Project.

- 12.3 Payment.** Invoices shall be rendered to the paying Party at the address specified in Appendix F. The Party receiving the invoice shall pay the invoice within thirty (30) Calendar Days of receipt. All payments shall be made in immediately available funds payable to the other Party, or by wire transfer to a bank named and account designated by the invoicing Party. Payment of invoices by either Party will not constitute a waiver of any rights or claims either Party may have under this Agreement.

- 12.4 Disputes.** In the event of a billing dispute between Transmission Owners and Interconnection Customer, Transmission Owners and the CAISO shall continue to provide Interconnection Service under this Agreement as long as Interconnection

Customer: (i) continues to make all payments not in dispute; and (ii) pays to Transmission Owners or into an independent escrow account the portion of the invoice in dispute, pending resolution of such dispute. If Interconnection Customer fails to meet these two requirements for continuation of service, then Transmission Owners may provide notice to Interconnection Customer of a Default pursuant to Article 17. Within thirty (30) Calendar Days after the resolution of the dispute, the Party that owes money to the other Party shall pay the amount due with interest calculated in accord with the methodology set forth in FERC's regulations at 18 CFR § 35.19a(a)(2)(iii). Notwithstanding the foregoing, any billing dispute between the CAISO, Interconnection Customer and/or SDG&E shall be resolved in accordance with the provisions of Article 27 of this Agreement.

Article 13. Emergencies

- 13.1 Definition.** "Emergency Condition" shall have the meaning set forth in Article 1.
- 13.2 Obligations.** Interconnection Customer, SDG&E and the CAISO shall comply with the Emergency Condition procedures of the CAISO, and all Parties shall comply with the Emergency Condition procedures of NERC, the Applicable Reliability Council, Applicable Reliability Standards, Applicable Laws and Regulations, and any emergency procedures set forth in this Agreement or agreed to by the Joint Operating Committee that are consistent with the other Emergency Condition procedures with which compliance is required by this Article 13.2.
- 13.3 Notice.** With respect to any facility which a Transmission Owner or the CAISO controls, the Transmission Owner or the CAISO shall notify Interconnection Customer promptly when it becomes aware of an Emergency Condition that affects Transmission Owners' Interconnection Facilities or such Transmission Owner's or the CAISO's Transmission System that may reasonably be expected to affect Interconnection Customer's operation of the Large Generating Facility or Interconnection Customer's Interconnection Facilities. Interconnection Customer shall notify Transmission Owners and the CAISO promptly when it becomes aware of an Emergency Condition that affects the Large Generating Facility or Interconnection Customer's Interconnection Facilities that may reasonably be expected to affect the Transmission Systems or Transmission Owners' Interconnection Facilities. To the extent information is known, the notification shall describe the Emergency Condition, the extent of the damage or deficiency, the expected effect on the operation of Interconnection Customer's or such Transmission Owner's or the CAISO's facilities and operations, its anticipated duration and the corrective action taken and/or to be taken. The initial notice shall be followed as soon as practicable with written notice, if requested by a Party, which may be provided by electronic mail or facsimile, or in the case of the CAISO may be publicly posted on the CAISO's internet website.
- 13.4 Immediate Action.** Unless, in Interconnection Customer's reasonable judgment, immediate action is required, Interconnection Customer shall obtain the consent of APS and the CAISO, such consent to not be unreasonably withheld, prior to performing any manual switching operations at the Large Generating Facility or Interconnection Customer's Interconnection Facilities in response to an Emergency Condition either declared by APS, on behalf of the Transmission Owners, or the CAISO or otherwise regarding the Transmission Systems.

13.5 Transmission Owner and CAISO Authority.

13.5.1 General. Transmission Owners and the CAISO may take whatever actions or inactions with regard to their affected Transmission Systems or Transmission Owners' Interconnection Facilities they deem necessary during an Emergency Condition in order to (i) preserve public health and safety, (ii) preserve the reliability of the affected Transmission Systems or Transmission Owners' Interconnection Facilities, (iii) limit or prevent damage, and (iv) expedite restoration of service.

Transmission Owners and the CAISO shall use Reasonable Efforts to minimize the effect of such actions or inactions on the Large Generating Facility or Interconnection Customer's Interconnection Facilities. APS, on behalf of Transmission Owners, and the CAISO may, on the basis of technical considerations, require the Large Generating Facility to mitigate an Emergency Condition by taking actions necessary and limited in scope to remedy the Emergency Condition, including, but not limited to, directing Interconnection Customer to shut-down, start-up, increase or decrease the real or reactive power output of the Large Generating Facility; implementing a reduction or disconnection pursuant to Article 13.5.2; directing Interconnection Customer to assist with blackstart (if available) or restoration efforts; or altering the outage schedules of the Large Generating Facility and Interconnection Customer's Interconnection Facilities. Subject to the provisions of Articles 9.6.1 and 9.6.2, Interconnection Customer shall comply with all of APS's operating instructions concerning Large Generating Facility real power and reactive power output within the manufacturer's design limitations of the Large Generating Facility's equipment that is in service and physically available for operation at the time, in compliance with Applicable Laws and Regulations and Applicable Reliability Standards.

13.5.2 Reduction and Disconnection. APS, on behalf of Transmission Owners, or the CAISO may reduce Interconnection Service, and APS may disconnect the Large Generating Facility or Interconnection Customer's Interconnection Facilities, when such reduction or disconnection is necessary under Good Utility Practice due to Emergency Conditions. These rights are separate and distinct from any right of curtailment of Transmission Owners or the CAISO pursuant to their respective Tariffs. When APS, on behalf of Transmission Owners, or the CAISO can schedule the reduction or disconnection in advance, APS or the CAISO shall notify Interconnection Customer of the reasons, timing and expected duration of the reduction or disconnection and shall coordinate with the other in accordance with Articles 9.7.1 and 9.7.2. APS and the CAISO shall coordinate with Interconnection Customer using Good Utility Practice to schedule the reduction or disconnection during periods of least impact to Interconnection Customer and Transmission Owners and the CAISO. Any reduction or disconnection shall continue only for so long as reasonably necessary under Good Utility Practice. The Parties shall cooperate with each other to restore the Large Generating Facility, the Interconnection Facilities, and the Transmission System to their normal operating state as soon as practicable consistent with Good Utility Practice.

- 13.6 Interconnection Customer Authority.** Consistent with Good Utility Practice, this Agreement and applicable Tariffs, Interconnection Customer may take actions or inactions with regard to the Large Generating Facility or Interconnection Customer's Interconnection Facilities during an Emergency Condition in order to (i) preserve public health and safety, (ii) preserve the reliability of the Large Generating Facility or Interconnection Customer's Interconnection Facilities, (iii) limit or prevent damage, and (iv) expedite restoration of service. Interconnection Customer shall use Reasonable Efforts to minimize the effect of such actions or inactions on the affected Transmission System(s) and Transmission Owners' Interconnection Facilities. Each affected Transmission Owner and the CAISO shall use Reasonable Efforts to assist Interconnection Customer in such actions.
- 13.7 Limited Liability.** Except as otherwise provided in Article 11.6.1 of this Agreement, no Party shall be liable to the others for any action it takes in responding to an Emergency Condition so long as such action is made in good faith and is consistent with Good Utility Practice.

Article 14. Regulatory Requirements and Governing Law

- 14.1 Regulatory Requirements.** A Party's obligations under this Agreement shall be subject to its receipt of any required approval or certificate from one or more Governmental Authorities in the form and substance satisfactory to the applying Party, or the Party making any required filings with, or providing notice to, such Governmental Authorities, and the expiration of any time period associated therewith. A Party shall in good faith seek and use its Reasonable Efforts to obtain such other approvals. Nothing in this Agreement shall require Interconnection Customer or other Party to take any action that could result in its inability to obtain, or its loss of, status or exemption under the Federal Power Act, the Public Utility Holding Company Act of 1935, as amended, or the Public Utility Regulatory Policies Act of 1978.
- 14.2 Governing Law.**
- 14.2.1** The validity, interpretation and performance of this Agreement and each of its provisions shall be governed by the laws of the state where the Point of Interconnection is located, without regard to its conflicts of law principles.
- 14.2.2** This Agreement is subject to all Applicable Laws and Regulations.
- 14.2.3** Each Party expressly reserves the right to seek changes in, appeal, or otherwise contest any laws, orders, rules, or regulations of a Governmental Authority.

Article 15. Notices.

- 15.1 General.** Unless otherwise provided in this Agreement, any notice, demand or request required or permitted to be given by a Party to the others and any instrument required or permitted to be tendered or delivered by a Party in writing to the others shall be effective when delivered and may be so given, tendered or delivered, by recognized national courier, or by depositing the same with the United States Postal Service with postage prepaid, for delivery by certified or registered mail, addressed to the Parties, or personally

delivered to the Parties, at the address set out in Appendix F, Addresses for Delivery of Notices and Billings.

A Party must update the information in Appendix F as information changes. A Party may change the notice information in this Agreement by giving five (5) Business Days written notice prior to the effective date of the change. Such changes shall not constitute an amendment to this Agreement.

- 15.2 Billings and Payments.** Billings and payments shall be sent to the addresses set out in Appendix F.
- 15.3 Alternative Forms of Notice.** Any notice or request required or permitted to be given by a Party to the other and not required by this Agreement to be given in writing may be so given by telephone, facsimile or email to the telephone numbers and email addresses set out in Appendix F.
- 15.4 Operations and Maintenance Notice.** APS and the CAISO shall notify the other Parties in writing of the identity of the person(s) that they designate as the point(s) of contact with respect to the implementation of Articles 9 and 10.

Article 16. Force Majeure

16.1 Force Majeure.

16.1.1 Economic hardship is not considered a Force Majeure event.

16.1.2 No Party shall be considered to be in Default with respect to any obligation hereunder, (including obligations under Article 4), other than the obligation to pay money when due, if prevented from fulfilling such obligation by Force Majeure. A Party unable to fulfill any obligation hereunder (other than an obligation to pay money when due) by reason of Force Majeure shall give notice and the full particulars of such Force Majeure to the other Parties in writing or by telephone as soon as reasonably possible after the occurrence of the cause relied upon. Telephone notices given pursuant to this article shall be confirmed in writing as soon as reasonably possible and shall specifically state full particulars of the Force Majeure, the time and date when the Force Majeure occurred and when the Force Majeure is reasonably expected to cease. The Party affected shall exercise due diligence to remove such disability with reasonable dispatch, but shall not be required to accede or agree to any provision not satisfactory to it in order to settle and terminate a strike or other labor disturbance.

Article 17. Default

17.1 Default

17.1.1 General. No Default shall exist where such failure to discharge an obligation (other than the payment of money or posting of security) is the result of Force Majeure as defined in this Agreement or the result of an act of omission of the other Parties. Upon a Breach, the affected non-Breaching Parties shall give written notice of such Breach to the Breaching Party. Except as provided in

Article 17.1.2, the Breaching Party shall have thirty (30) Calendar Days from receipt of the Default notice within which to cure such Breach; provided however, if such Breach is not capable of cure within thirty (30) Calendar Days, the Breaching Party shall commence such cure within thirty (30) Calendar Days after notice and continuously and diligently complete such cure within ninety (90) Calendar Days from receipt of the Default notice; and, if cured within such time, the Breach specified in such notice shall cease to exist. If one but not both of the entities comprising the Interconnection Customer breaches this Agreement, the non-Breaching Party shall accept performance from the Interconnection Customer entity to the extent it continues to perform under this Agreement.

17.1.2 Right to Terminate. If a Breach is not cured as provided in this article or as provided in Article 11.5.3 with respect to the posting of financial security, or if a Breach is not capable of being cured within the period provided for herein, an affected non-Breaching Party shall have the right to declare a Default and terminate this Agreement by written notice at any time until cure occurs, and be relieved of any further obligation hereunder and, whether or not that Party terminates this Agreement, to recover from the Breaching Party all amounts due hereunder, plus all other damages and remedies to which it is entitled at law or in equity. The provisions of this article will survive termination of this Agreement.

Article 18. Indemnity, Consequential Damages and Insurance

18.1 Indemnity. A Party shall at all times indemnify, defend, and hold another Party, harmless from, any and all Losses arising out of or resulting from that particular Party's actions or inactions of its obligations under this Agreement on behalf of the indemnifying Party, except in cases of gross negligence or intentional wrongdoing by the indemnified Party.

18.1.1 Indemnified Party. If an indemnified Party is entitled to indemnification under this Article 18 as a result of a claim by a third party, and the indemnifying Party fails, after notice and reasonable opportunity to proceed under Article 18.1, to assume the defense of such claim, such indemnified Party may at the expense of the indemnifying Party contest, settle or consent to the entry of any judgment with respect to, or pay in full, such claim.

18.1.2 Indemnifying Party. If an indemnifying Party is obligated to indemnify and hold any indemnified Party harmless under this Article 18, the amount owing to the indemnified Party shall be the amount of such indemnified Party's actual Loss, net of any insurance or other recovery.

18.1.3 Indemnity Procedures. Promptly after receipt by an indemnified Party of any claim or notice of the commencement of any action or administrative or legal proceeding or investigation as to which the indemnity provided for in Article 18.1 may apply, the indemnified Party shall notify the indemnifying Party of such fact. Any failure of or delay in such notification shall not affect a Party's indemnification obligation unless such failure or delay is materially prejudicial to the indemnifying Party.

The indemnifying Party shall have the right to assume the defense thereof with counsel designated by such indemnifying Party and reasonably satisfactory to the indemnified Party. If the defendants in any such action include one or more indemnified Parties and the indemnifying Party and if the indemnified Party reasonably concludes that there may be legal defenses available to it and/or other indemnified Parties which are different from or additional to those available to the indemnifying Party, the indemnified Party shall have the right to select separate counsel to assert such legal defenses and to otherwise participate in the defense of such action on its own behalf. In such instances, the indemnifying Party shall only be required to pay the fees and expenses of one additional attorney to represent an indemnified Party or indemnified Parties having such differing or additional legal defenses.

The indemnified Party shall be entitled, at its expense, to participate in any such action, suit or proceeding, the defense of which has been assumed by the indemnifying Party. Notwithstanding the foregoing, the indemnifying Party (i) shall not be entitled to assume and control the defense of any such action, suit or proceedings if and to the extent that, in the opinion of the indemnified Party and its counsel, such action, suit or proceeding involves the potential imposition of criminal liability on the indemnified Party, or there exists a conflict or adversity of interest between the indemnified Party and the indemnifying Party, in such event the indemnifying Party shall pay the reasonable expenses of the indemnified Party, and (ii) shall not settle or consent to the entry of any judgment in any action, suit or proceeding without the consent of the indemnified Party, which shall not be reasonably withheld, conditioned or delayed.

18.2 Consequential Damages. In no event shall a Party be liable under any provision of this Agreement for any losses, damages, costs or expenses for any special, indirect, incidental, consequential, or punitive damages, including but not limited to loss of profit or revenue, loss of the use of equipment, cost of capital, cost of temporary equipment or services, whether based in whole or in part in contract, in tort, including negligence, strict liability, or any other theory of liability; provided, however, that damages for which a Party may be liable to another Party under another agreement will not be considered to be special, indirect, incidental, or consequential damages hereunder.

18.3 Insurance. A Party shall, at its own expense, maintain in force throughout the period of this Agreement, and until released by the other Party(ies), the following minimum insurance coverages, with insurers authorized to do business in the state where the Point of Interconnection is located:

18.3.1 Employer's Liability and Workers' Compensation Insurance providing statutory benefits in accordance with the laws and regulations of the state in which the Point of Interconnection is located, except in the case of the CAISO, the State of California.

18.3.2 Commercial General Liability Insurance including premises and operations, personal injury, broad form property damage, broad form blanket contractual liability coverage (including coverage for the contractual indemnification) products and completed operations coverage, coverage for explosion, collapse and underground hazards, independent contractors coverage, coverage for

pollution to the extent normally available and punitive damages to the extent normally available and a cross liability endorsement, with minimum limits of One Million Dollars (\$1,000,000) per occurrence/One Million Dollars (\$1,000,000) aggregate combined single limit for personal injury, bodily injury, including death and property damage.

- 18.3.3** Business Automobile Liability Insurance for coverage of owned and non-owned and hired vehicles, trailers or semi-trailers designed for travel on public roads, with a minimum, combined single limit of One Million Dollars (\$1,000,000) per occurrence for bodily injury, including death, and property damage.
- 18.3.4** Excess Public Liability Insurance over and above the Employer's Liability Commercial General Liability and Business Automobile Liability Insurance coverage, with a minimum combined single limit of Twenty Million Dollars (\$20,000,000) per occurrence/Twenty Million Dollars (\$20,000,000) aggregate.
- 18.3.5** The Commercial General Liability Insurance, Business Automobile Insurance and Excess Public Liability Insurance policies shall name the other Party, their parents, associated and Affiliate companies and their respective directors, officers, agents, servants and employees ("Other Party Group") as additional insured. All policies shall contain provisions whereby the insurers waive all rights of subrogation in accordance with the provisions of this Agreement against the Other Party Group and provide thirty (30) Calendar Days advance written notice to the Other Party Group prior to anniversary date of cancellation or any material change in coverage or condition.
- 18.3.6** The Commercial General Liability Insurance, Business Automobile Liability Insurance and Excess Public Liability Insurance policies shall contain provisions that specify that the policies are primary and shall apply to such extent without consideration for other policies separately carried and shall state that each insured is provided coverage as though a separate policy had been issued to each, except the insurer's liability shall not be increased beyond the amount for which the insurer would have been liable had only one insured been covered. Each Party shall be responsible for its respective deductibles or retentions.
- 18.3.7** The Commercial General Liability Insurance, Business Automobile Liability Insurance and Excess Public Liability Insurance policies, if written on a Claims First Made Basis, shall be maintained in full force and effect for two (2) years after termination of this Agreement, which coverage may be in the form of tail coverage or extended reporting period coverage if agreed by the Parties.
- 18.3.8** The requirements contained herein as to the types and limits of all insurance to be maintained by the Parties are not intended to and shall not in any manner, limit or qualify the liabilities and obligations assumed by the Parties under this Agreement.
- 18.3.9** Within ten (10) Calendar Days following execution of this Agreement, and as soon as practicable after the end of each fiscal year or at the renewal of the insurance policy and in any event within ninety (90) Calendar Days thereafter,

each Party shall provide certification of all insurance required in this Agreement, executed by each insurer or by an authorized representative of each insurer.

18.3.10 Notwithstanding the foregoing, each Party may self-insure to meet the minimum insurance requirements of Articles 18.3.2 through 18.3.8 to the extent it maintains a self-insurance program; provided that, such Party's senior unsecured debt or issuer rating is BBB-, or better as rated by Standard & Poor's and that its self-insurance program meets the minimum insurance requirements of Articles 18.3.2 through 18.3.8. For any period of time that a Party's senior unsecured debt rating and issuer rating are both rated at less than BBB- by Standard & Poor's, such Party shall comply with the insurance requirements applicable to it under Articles 18.3.2 through 18.3.9. In the event that a Party is permitted to self-insure pursuant to this article, it shall notify the other Parties that it meets the requirements to self-insure and that its self-insurance program meets the minimum insurance requirements in a manner consistent with that specified in Article 18.3.9.

18.3.11 The Parties agree to report to each other in writing as soon as practical all accidents or occurrences resulting in injuries to any person, including death, and any property damage arising out of this Agreement.

Article 19. Assignment

19.1 Assignment. This Agreement may be assigned by a Party only with the written consent of the other Parties; provided that a Party may assign this Agreement without the consent of the other Parties to any Affiliate of the assigning Party with an equal or greater credit rating and with the legal authority and operational ability to satisfy the obligations of the assigning Party under this Agreement; and provided further that Interconnection Customer shall have the right to assign this Agreement, without the consent of the other Parties, for collateral security purposes to aid in providing financing for the Large Generating Facility or a Project Phase of the Large Generating Facility, provided that Interconnection Customer will promptly notify the Parties of any such assignment. Any financing arrangement entered into by Interconnection Customer pursuant to this article will provide that prior to or upon the exercise of the secured party's, trustee's or mortgagee's assignment rights pursuant to said arrangement, the secured creditor, the trustee or mortgagee will notify the Parties of the date and particulars of any such exercise of assignment right(s), including providing the Parties with proof that it meets the requirements of Articles 11.5 and 18.3. Any attempted assignment that violates this article is void and ineffective. Any assignment under this Agreement shall not relieve a Party of its obligations, nor shall a Party's obligations be enlarged, in whole or in part, by reason thereof. Where required, consent to assignment will not be unreasonably withheld, conditioned or delayed.

Article 20. Severability

20.1 Severability. If any provision in this Agreement is finally determined to be invalid, void or unenforceable by any court or other Governmental Authority having jurisdiction, such determination shall not invalidate, void or make unenforceable any other provision, agreement or covenant of this Agreement; provided that if Interconnection Customer (or any third party, but only if such third party is not acting at the direction of a Transmission

Owner or the CAISO) seeks and obtains such a final determination with respect to any provision of the Alternate Option (Article 5.1.2), or the Negotiated Option (Article 5.1.4), then none of these provisions shall thereafter have any force or effect and the Parties' rights and obligations shall be governed solely by the Standard Option (Article 5.1.1).

Article 21. Comparability

21.1 Comparability. The Parties which are FERC-jurisdictional public utilities will comply with all applicable comparability and code of conduct laws, rules and regulations, as amended from time to time. For clarity and avoidance of ambiguity, IID is not a jurisdictional public utility to whom Section 205 or 206 of the Federal Power Act or FERC rules and regulations thereunder apply.

Article 22. Confidentiality

22.1 Confidentiality. Confidential Information shall include, without limitation, all information relating to a Party's technology, research and development, business affairs, and pricing, and any information supplied by any of the Parties to the other prior to the execution of this Agreement.

Information is Confidential Information only if it is clearly designated or marked in writing as confidential on the face of the document, or, if the information is conveyed orally or by inspection, if the Party providing the information orally informs the Parties receiving the information that the information is confidential.

If requested by any Party, the other Parties shall provide in writing, the basis for asserting that the information referred to in this Article 22 warrants confidential treatment, and the requesting Party may disclose such writing to the appropriate Governmental Authority. Each Party shall be responsible for the costs associated with affording confidential treatment to its information.

22.1.1 Term. During the term of this Agreement, and for a period of three (3) years after the expiration or termination of this Agreement, except as otherwise provided in this Article 22, each Party shall hold in confidence and shall not disclose to any person Confidential Information.

22.1.2 Scope. Confidential Information shall not include information that the receiving Party can demonstrate: (1) is generally available to the public other than as a result of a disclosure by the receiving Party; (2) was in the lawful possession of the receiving Party on a non-confidential basis before receiving it from the disclosing Party; (3) was supplied to the receiving Party without restriction by a third party, who, to the knowledge of the receiving Party after due inquiry, was under no obligation to the disclosing Party to keep such information confidential; (4) was independently developed by the receiving Party without reference to Confidential Information of the disclosing Party; (5) is, or becomes, publicly known, through no wrongful act or omission of the receiving Party or Breach of this Agreement; or (6) is required, in accordance with Article 22.1.7 of the Agreement, Order of Disclosure, to be disclosed by any Governmental Authority or is otherwise required to be disclosed by law or subpoena, or is necessary in any legal proceeding establishing rights and obligations under this Agreement.

Information designated as Confidential Information will no longer be deemed confidential if the Party that designated the information as confidential notifies the other Parties that it no longer is confidential.

22.1.3 Release of Confidential Information. No Party shall release or disclose Confidential Information to any other person, except to its Affiliates (limited by the Standards of Conduct requirements set forth in Part 358 of FERC's Regulations, 18 C.F.R. 358), subcontractors, employees, consultants, or to parties who may be or considering providing financing to or equity participation with Interconnection Customer, or to potential purchasers or assignees of Interconnection Customer, on a need-to-know basis in connection with this Agreement, unless such person has first been advised of the confidentiality provisions of this Article 22 and has agreed to comply with such provisions. Notwithstanding the foregoing, a Party providing Confidential Information to any person shall remain primarily responsible for any release of Confidential Information in contravention of this Article 22.

22.1.4 Rights. Each Party retains all rights, title, and interest in the Confidential Information that each Party discloses to the other Parties. The disclosure by each Party to the other Parties of Confidential Information shall not be deemed a waiver by a Party or any other person or entity of the right to protect the Confidential Information from public disclosure.

22.1.5 No Warranties. By providing Confidential Information, no Party makes any warranties or representations as to its accuracy or completeness. In addition, by supplying Confidential Information, no Party obligates itself to provide any particular information or Confidential Information to the other Parties nor to enter into any further agreements or proceed with any other relationship or joint venture.

22.1.6 Standard of Care. A Party shall use at least the same standard of care to protect Confidential Information it receives as it uses to protect its own Confidential Information from unauthorized disclosure, publication or dissemination. A Party may use Confidential Information solely to fulfill its obligations to the other Parties under this Agreement or its regulatory requirements.

22.1.7 Disclosure Required by Law or Order. If a court or a Government Authority or entity with the right, power, and apparent authority to do so requests or requires a Party, by subpoena, oral deposition, interrogatories, requests for production of documents, administrative order, or otherwise, to disclose Confidential Information, that Party shall provide the other Parties with prompt notice of such request(s) or requirement(s) so that the other Parties may seek an appropriate protective order or waive compliance with the terms of this Agreement. Notwithstanding the absence of a protective order or waiver, the Party may disclose such Confidential Information which, in the opinion of its counsel, the Party is legally compelled to disclose, including any Confidential Information that, in the opinion of IID's counsel, IID is legally compelled to disclose under California public record laws. A Party will use Reasonable Efforts to obtain reliable assurance that confidential treatment will be accorded any Confidential Information so furnished.

- 22.1.8 Termination of Agreement.** Upon termination of this Agreement for any reason, each Party shall, within ten (10) Calendar Days of receipt of a written request from another Party, use Reasonable Efforts to destroy, erase, or delete (with such destruction, erasure, and deletion certified in writing to the other Parties) or return to another Party, without retaining copies thereof, any and all written or electronic Confidential Information received from the other Party.
- 22.1.9 Remedies.** The Parties agree that monetary damages would be inadequate to compensate a Party for another Party's Breach of its obligations under this Article 22. Each Party accordingly agrees that the other Parties shall be entitled to equitable relief, by way of injunction or otherwise, if the first Party Breaches or threatens to Breach its obligations under this Article 22, which equitable relief shall be granted without bond or proof of damages, and the receiving Party shall not plead in defense that there would be an adequate remedy at law. Such remedy shall not be deemed an exclusive remedy for the Breach of this Article 22, but shall be in addition to all other remedies available at law or in equity. The Parties further acknowledge and agree that the covenants contained herein are necessary for the protection of legitimate business interests and are reasonable in scope. No Party, however, shall be liable for indirect, incidental, or consequential or punitive damages of any nature or kind resulting from or arising in connection with this Article 22.
- 22.1.10 Disclosure to FERC, its Staff, or a State.** Notwithstanding anything in this Article 22 to the contrary, and pursuant to 18 CFR section 1b.20, if FERC or its staff, during the course of an investigation or otherwise, requests information from one of the Parties that is otherwise required to be maintained in confidence pursuant to this Agreement, the Party shall provide the requested information to FERC or its staff, within the time provided for in the request for information. In providing the information to FERC or its staff, the Party must, consistent with 18 CFR section 388.112, request that the information be treated as confidential and non-public by FERC and its staff and that the information be withheld from public disclosure. Parties are prohibited from notifying the other Party to this Agreement prior to the release of the Confidential Information to FERC or its staff. The Party shall notify the other Parties to the Agreement when it is notified by FERC or its staff that a request to release Confidential Information has been received by FERC, at which time any of the Parties may respond before such information would be made public, pursuant to 18 CFR section 388.112. Requests from a state regulatory body conducting a confidential investigation shall be treated in a similar manner if consistent with the applicable state rules and regulations.
- 22.1.11** Subject to the exception in Article 22.1.10, Confidential Information shall not be disclosed by the other Parties to any person not employed or retained by the other Parties, except to the extent disclosure is (i) required by law; (ii) reasonably deemed by the disclosing Party to be required to be disclosed in connection with a dispute between or among the Parties, or the defense of litigation or dispute; (iii) otherwise permitted by consent of the other Parties, such consent not to be unreasonably withheld; or (iv) necessary to fulfill its obligations under this Agreement or as a transmission service provider or a Balancing Authority

including disclosing the Confidential Information to an RTO or ISO or to a regional or national reliability organization. The Party asserting confidentiality shall notify the other Party in writing of the information it claims is confidential. Prior to any disclosures of another Party's Confidential Information under this subparagraph, or if any third party or Governmental Authority makes any request or demand for any of the information described in this subparagraph, the disclosing Party agrees to promptly notify the other Party in writing and agrees to assert confidentiality and cooperate with the other Party in seeking to protect the Confidential Information from public disclosure by confidentiality agreement, protective order or other reasonable measures.

Article 23. Environmental Releases

23.1 Each Party shall notify the other Parties, first orally and then in writing, of the release of any Hazardous Substances, any asbestos or lead abatement activities, or any type of remediation activities related to the Large Generating Facility or the Interconnection Facilities, each of which may reasonably be expected to affect the other Party. The notifying Party shall: (i) provide the notice as soon as practicable, provided such Parties makes a good faith effort to provide the notice no later than twenty-four hours after such Party becomes aware of the occurrence; and (ii) promptly furnish to the other Parties copies of any publicly available reports filed with any Governmental Authorities addressing such events.

Article 24. Information Requirements

24.1 Information Acquisition. APS, on behalf of Transmission Owners, and Interconnection Customer shall submit specific information regarding the electrical characteristics of their respective facilities to each other as described below and in accordance with Applicable Reliability Standards.

24.2 Information Submission by APS, on behalf of Transmission Owners. The initial information submission by APS, on behalf of Transmission Owners, shall occur no later than one hundred eighty (180) Calendar Days prior to Trial Operation of a Project Phase and shall include Transmission System information necessary to allow Interconnection Customer to select equipment and meet any system protection and stability requirements, unless otherwise agreed to by the Parties. On a monthly basis APS, on behalf of Transmission Owners, shall provide Interconnection Customer and the CAISO a status report on the construction and installation of Transmission Owners' Interconnection Facilities and Network Upgrades, including, but not limited to, the following information: (1) progress to date; (2) a description of the activities since the last report (3) a description of the action items for the next period; and (4) the delivery status of equipment ordered.

24.3 Updated Information Submission by Interconnection Customer. The updated information submission by Interconnection Customer, including manufacturer information, shall occur no later than one hundred eighty (180) Calendar Days prior to the Trial Operation of a Project Phase. Interconnection Customer shall submit a completed copy of the Large Generating Facility data requirements contained in Appendix 1 to the LGIP. It shall also include any additional updates to information provided to APS and CAISO for the Interconnection Feasibility, Interconnection

Facilities Study, and the CAISO Phase II Interconnection Study, as applicable. Information in this submission shall be the most current Large Generating Facility design or expected performance data. Information submitted for stability models shall be compatible with APS's and the CAISO's standard models. If there is no compatible model, Interconnection Customer will work with a consultant mutually agreed to by the Parties to develop and supply a standard model and associated information.

If Interconnection Customer's data is materially different from what was originally provided to APS or the CAISO pursuant to the Interconnection Study Agreements between APS or the CAISO and Interconnection Customer, then APS or the CAISO, as applicable, will conduct appropriate studies to determine the impact on the Transmission System based on the actual data submitted pursuant to this Article 24.3. The Interconnection Customer shall not begin Trial Operation of a Project Phase until such studies are completed and all other applicable requirements of this Agreement are satisfied.

If Interconnection Customer's data is materially different from what was originally provided to IID by the CAISO or by the Interconnection Customer pursuant to the Affected System Study Agreement, then IID also shall have the right, but not the obligation, to conduct any appropriate Affected System Study necessary to determine the impact on its non-JPP transmission facilities based on the actual data submitted pursuant to this Article 24.3. To the extent IID exercises this right, Interconnection Customer shall not begin Trial Operation of a Project Phase until such studies are completed and all other applicable requirements of this Agreement are satisfied.

24.4 Information Supplementation. Prior to Trial Operation of a Project Phase, the Parties shall supplement their information submissions described above in this Article 24 with any and all "as-built" Large Generating Facility information or "as-tested" performance information that differs from the initial submissions or, alternatively, written confirmation that no such differences exist. The Interconnection Customer shall conduct tests on the Large Generating Facility as required by Good Utility Practice such as an open circuit "step voltage" test on the Large Generating Facility to verify proper operation of the Large Generating Facility's automatic voltage regulator.

Unless otherwise agreed, the test conditions shall include: (1) Large Generating Facility at synchronous speed; (2) automatic voltage regulator on and in voltage control mode; and (3) a five percent change in Large Generating Facility terminal voltage initiated by a change in the voltage regulators reference voltage. Interconnection Customer shall provide validated test recordings showing the responses of Large Generating Facility terminal and field voltages. In the event that direct recordings of these voltages is impractical, recordings of other voltages or currents that mirror the response of the Large Generating Facility's terminal or field voltage are acceptable if information necessary to translate these alternate quantities to actual Large Generating Facility terminal or field voltages is provided. Large Generating Facility testing shall be conducted and results provided to APS and the CAISO at the request of APS and the CAISO.

Subsequent to the Commercial Operation Date for a Project Phase, Interconnection Customer shall provide APS and the CAISO any information changes due to equipment replacement, repair, or adjustment. APS, on behalf of Transmission Owners, shall provide Interconnection Customer any information changes due to equipment

replacement, repair or adjustment in the directly connected substation or any adjacent Transmission Owners' substation that may affect Interconnection Customer's Interconnection Facilities equipment ratings, protection or operating requirements. The Parties shall provide such information pursuant to Article 5.19.

Article 25. Information Access and Audit Rights

- 25.1 Information Access.** Each Party (the "disclosing Party") shall make available to the other Parties information that is in the possession of the disclosing Party and is necessary in order for the other Parties to: (i) verify the costs incurred by the disclosing Party for which another Party is responsible under this Agreement; and (ii) carry out its obligations and responsibilities under this Agreement. The Parties shall not use such information for purposes other than those set forth in this Article 25.1 and to enforce their rights under this Agreement. Nothing in this Article 25 shall obligate a Party to make available to another Party any third party information in its possession or control if making such third party information available would violate a Tariff or other legal restriction on the use or disclosure of such third party information.
- 25.2 Reporting of Non-Force Majeure Events.** Each Party (the "notifying Party") shall notify the other Parties when the notifying Party becomes aware of its inability to comply with the provisions of this Agreement for a reason other than a Force Majeure event. The Parties agree to cooperate with each other and provide necessary information regarding such inability to comply, including the date, duration, reason for the inability to comply, and corrective actions taken or planned to be taken with respect to such inability to comply. Notwithstanding the foregoing, notification, cooperation or information provided under this article shall not entitle the Parties receiving such notification to allege a cause for anticipatory breach of this Agreement.
- 25.3 Audit Rights.** Subject to the requirements of confidentiality under Article 22 of this Agreement, each Party shall have the right, during normal business hours, and upon prior reasonable notice to the other Party, to audit at its own expense the other Party's accounts and records pertaining to either such Party's performance or either such Party's satisfaction of obligations under this Agreement. Such audit rights shall include audits of the other Party's costs pertaining to such Party's performance or satisfaction of obligations owned to the other Party under this Agreement, calculation of invoiced amounts, APS's and the CAISO's efforts to allocate responsibility for the provision of reactive support to the Transmission System, Transmission Owners' and the CAISO's efforts to allocate responsibility for interruption or reduction of generation on the Transmission System, and each Party's actions in an Emergency Condition. Any audit authorized by this article shall be performed at the offices where such accounts and records are maintained and shall be limited to those portions of such accounts and records that relate to each such Party's performance and satisfaction of obligations under this Agreement. Each such Party shall keep such accounts and records for a period equivalent to the audit rights periods described in Article 25.4. Notwithstanding anything to the contrary in Article 25, each Party's rights to audit APS's, IID's, SDG&E's or the CAISO's accounts and records shall be subject to their respective Tariffs.
- 25.4 Audit Rights Periods.**

25.4.1 Audit Rights Period for Construction-Related Accounts and Records. Accounts and records related to the design, engineering, procurement, and construction of Transmission Owners' Interconnection Facilities and Network Upgrades shall be subject to audit for a period of twenty-four months following issuances of final invoices in accordance with Article 12.2.

25.4.2 Audit Rights Period for All Other Accounts and Records. Accounts and records related to either Party's performance or satisfaction of all obligations under this Agreement other than those described in Article 25.4.1 shall be subject to audit as follows: (i) for an audit relating to cost obligations, the applicable audit rights period shall be twenty-four months after the auditing Party's receipt of an invoice giving rise to such cost obligations; and (ii) for an audit relating to all other obligations, the applicable audit rights period shall be twenty-four months after the event for which the audit is sought.

25.5 Audit Results. If an audit by a Party determines that an overpayment or an underpayment has occurred, a notice of such overpayment or underpayment shall be given to the other Parties together with those records from the audit which support such determination.

Article 26. Subcontractors

26.1 General. Nothing in this Agreement shall prevent a Party from utilizing the services of any subcontractor as it deems appropriate to perform its obligations under this Agreement; provided, however, that each Party shall require its subcontractors to comply with all applicable terms and conditions of this Agreement in providing such services and each Party shall remain primarily liable to the other Party for the performance of such subcontractor.

26.2 Responsibility of Principal. The creation of any subcontract relationship shall not relieve the hiring Party of any of its obligations under this Agreement. The hiring Party shall be fully responsible to the other Parties for the acts or omissions of any subcontractor the hiring Party hires as if no subcontract had been made; provided, however, that in no event shall Transmission Owners or the CAISO be liable for the actions or inactions of Interconnection Customer or its subcontractors with respect to obligations of Interconnection Customer under Article 5 of this Agreement. Any applicable obligation imposed by this Agreement upon the hiring Party shall be equally binding upon, and shall be construed as having application to, any subcontractor of such Party.

26.3 No Limitation by Insurance. The obligations under this Article 26 will not be limited in any way by any limitation of subcontractor's insurance.

Article 27. Disputes

Disputes between the Interconnection Customer, CAISO and/or SDG&E arising out of requirements of the CAISO Tariff shall be settled in accordance with the provisions of Article 13 of the CAISO Tariff, except that references to the CAISO Tariff in such Article 13 of the CAISO Tariff shall be read as references to this Agreement. Disputes between the Interconnection

Customer and IID arising out of the Affected System Study Agreement or Affected System Construction and Operation Agreement shall be resolved in accordance with the provisions of Section 13.5 of the Generation Interconnection Procedures in IID's Tariff. All other disputes shall be resolved as follows:

27.1 Submission. In the event a Party has a dispute, or asserts a claim, that arises out of or in connection with this Agreement or its performance, such Party (the "disputing Party") shall provide the other Parties with written notice of the dispute or claim ("Notice of Dispute"). Such dispute or claim shall be referred to a designated senior representative of each Party for resolution on an informal basis as promptly as practicable after receipt of the Notice of Dispute by the other Parties. In the event the designated representatives are unable to resolve the claim or dispute through unassisted or assisted negotiations within thirty (30) Calendar Days of the other Parties' receipt of the Notice of Dispute, such claim or dispute may, upon mutual agreement of the Parties, be submitted to arbitration and resolved in accordance with the arbitration procedures set forth below. In the event the Parties do not agree to submit such claim or dispute to arbitration, any Party may exercise whatever rights and remedies it may have in equity or at law consistent with the terms of this Agreement.

27.2 External Arbitration Procedures. Any arbitration initiated under this Agreement shall be conducted before a single neutral arbitrator appointed by the Parties, or in the absence of such appointment, by selection by the American Arbitration Association. The arbitrator shall be knowledgeable in electric utility matters, including electric transmission and bulk power issues, and shall not have any current or past substantial business or financial relationships with any party to the arbitration (except prior arbitration). The arbitrator shall provide each of the Parties an opportunity to be heard and, except as otherwise provided herein, shall conduct the arbitration in accordance with the Commercial Arbitration Rules of the American Arbitration Association ("Arbitration Rules") and any applicable FERC regulations; provided, however, in the event of a conflict between the Arbitration Rules and the terms of this Article 27, the terms of this Article 27 shall prevail.

27.3 Arbitration Decisions. Unless otherwise agreed by the Parties, the arbitrator shall render a decision within ninety (90) Calendar Days of appointment and shall notify the Parties in writing of such decision and the reasons therefor. The arbitrator shall be authorized only to interpret and apply the provisions of this Agreement and shall have no power to modify or change any provision of this Agreement in any manner. The decision of the arbitrator shall be final and binding upon the Parties, and judgment on the award may be entered in any court having jurisdiction. The decision of the arbitrator may be appealed solely on the grounds that the conduct of the arbitrator, or the decision itself, violated the standards set forth in the Federal Arbitration Act or the Administrative Dispute Resolution Act. The final decision of the arbitrator must also be filed with FERC if it affects jurisdictional rates, terms and conditions of service, Interconnection Facilities, or Network Upgrades.

27.4 Costs. Each Party shall be responsible for its own costs incurred during the arbitration process and for its per capita share of the cost of the arbitrator.

Article 28. Representations, Warranties, and Covenants

28.1 General. Each Party makes the following representations, warranties and covenants:

28.1.1 Good Standing. Such Party is duly organized, validly existing and in good standing under the laws of the state in which it is organized, formed, or incorporated, as applicable; that it is qualified to do business in the state or states in which the Large Generating Facility, Interconnection Facilities and Network Upgrades owned by such Party, as applicable, are located; and that it has the corporate power and authority to own its properties, to carry on its business as now being conducted and to enter into this Agreement and carry out the transactions contemplated hereby and perform and carry out all covenants and obligations on its part to be performed under and pursuant to this Agreement.

28.1.2 Authority. Such Party has the right, power and authority to enter into this Agreement, to become a Party hereto and to perform its obligations hereunder. This Agreement is a legal, valid and binding obligation of such Party, enforceable against such Party in accordance with its terms, except as the enforceability thereof may be limited by applicable bankruptcy, insolvency, reorganization or other similar laws affecting creditors' rights generally and by general equitable principles (regardless of whether enforceability is sought in a proceeding in equity or at law).

28.1.3 No Conflict. The execution, delivery and performance of this Agreement does not violate or conflict with the organizational or formation documents, or bylaws or operating agreement, of such Party, or any judgment, license, permit, order, material agreement or instrument applicable to or binding upon such Party or any of its assets.

28.1.4 Consent and Approval. Such Party has sought or obtained, or, in accordance with this Agreement will seek or obtain, each consent, approval, authorization, order, or acceptance by any Governmental Authority in connection with the execution, delivery and performance of this Agreement, and it will provide to any Governmental Authority notice of any actions under this Agreement that are required by Applicable Laws and Regulations.

Article 29. Joint Operating Committee

29.1 Joint Operating Committee. APS, on behalf of the Transmission Owners, shall constitute a Joint Operating Committee to coordinate operating and technical considerations of Interconnection Service. At least six (6) months prior to the expected Initial Synchronization Date, APS and Interconnection Customer shall appoint one representative and one alternate to the Joint Operating Committee. APS and Interconnection Customer shall notify each other of its appointment in writing. Such appointments may be changed at any time by similar notice. The Joint Operating Committee shall meet as necessary, but not less than once each calendar year, to carry out the duties set forth herein. The Joint Operating Committee shall hold a meeting at the request of any Party, at a time and place agreed upon by the representatives of the Joint Operating Committee. The Joint Operating Committee shall perform all of its duties consistent with the provisions of this Agreement. Each Party shall cooperate in providing to the Joint Operating Committee all information required in the performance of the Joint Operating Committee's duties. All decisions and agreements, if any, made by the Joint

Operating Committee, shall be evidenced in writing. The duties of the Joint Operating Committee shall include the following:

- 29.1.1** Establish data requirements and operating record requirements.
- 29.1.2** Review the requirements, standards, and procedures for data acquisition equipment, protective equipment, and any other equipment or software.
- 29.1.3** Annually review the one (1) year forecast of maintenance and planned outage schedules of Transmission Owners' and Interconnection Customer's facilities at the Point of Interconnection.
- 29.1.4** Coordinate the scheduling of maintenance and planned outages on the Interconnection Facilities, the Large Generating Facility and other facilities that impact the normal operation of the interconnection of the Large Generating Facility to the Transmission System.
- 29.1.5** Ensure that information is being provided by each Party regarding equipment availability.
- 29.1.6** Perform such other duties as may be conferred upon it by mutual agreement of the Parties.

Article 30. Miscellaneous

- 30.1 Binding Effect.** This Agreement and the rights and obligations hereof, shall be binding upon and shall inure to the benefit of the successors and assigns of the Parties hereto.
- 30.2 Conflicts.** In the event of a conflict between the body of this Agreement and any attachment, appendices or exhibits hereto, the terms and provisions of the body of this Agreement shall prevail and be deemed the final intent of the Parties.
- 30.3 Rules of Interpretation.** This Agreement, unless a clear contrary intention appears, shall be construed and interpreted as follows: (1) the singular number includes the plural number and vice versa; (2) reference to any person includes such person's successors and assigns but, in the case of a Party, only if such successors and assigns are permitted by this Agreement, and reference to a person in a particular capacity excludes such person in any other capacity or individually; (3) reference to any agreement (including this Agreement), document, instrument or tariff means such agreement, document, instrument, or tariff as amended or modified and in effect from time to time in accordance with the terms thereof and, if applicable, the terms hereof; (4) reference to any Applicable Laws and Regulations means such Applicable Laws and Regulations as amended, modified, codified, or reenacted, in whole or in part, and in effect from time to time, including, if applicable, rules and regulations promulgated thereunder; (5) unless expressly stated otherwise, reference to any Article, Section or Appendix means such Article of this Agreement or such Appendix to this Agreement, or such Section to the applicable Large Generator Interconnection Procedures or such Appendix to the applicable Large Generator Interconnection Procedures, as the case may be; (6) "hereunder", "hereof", "herein", "hereto" and words of similar import shall be deemed references to this Agreement as a whole and not to any particular Article or other

provision hereof or thereof; (7) "including" (and with correlative meaning "include") means including without limiting the generality of any description preceding such term; and (8) relative to the determination of any period of time, "from" means "from and including", "to" means "to but excluding" and "through" means "through and including".

30.4 Entire Agreement. This Agreement, including all Appendices and Schedules attached hereto, constitutes the entire agreement among all of the Parties with reference to the subject matter hereof, and supersedes all prior and contemporaneous understandings or agreements, oral or written, among the Parties with respect to the subject matter of this Agreement. There are no other agreements (other than the Affected System Study Agreement and Affected System Construction and Operation Agreement), representations, warranties, or covenants which constitute any part of the consideration for, or any condition to, any Party's compliance with its obligations under this Agreement.

30.5 No Third Party Beneficiaries. This Agreement is not intended to and does not create rights, remedies, or benefits of any character whatsoever in favor of any persons, corporations, associations, or entities other than the Parties, and the obligations herein assumed are solely for the use and benefit of the Parties, their successors in interest and, where permitted, their assigns.

30.6 Waiver. The failure of a Party to this Agreement to insist, on any occasion, upon strict performance of any provision of this Agreement will not be considered a waiver of any obligation, right, or duty of, or imposed upon, such Party.

Any waiver at any time by either Party of its rights with respect to this Agreement shall not be deemed a continuing waiver or a waiver with respect to any other failure to comply with any other obligation, right, duty of this Agreement. Termination or Default of this Agreement for any reason by Interconnection Customer shall not constitute a waiver of Interconnection Customer's legal rights to obtain an interconnection from Transmission Owner. Any waiver of this Agreement shall, if requested, be provided in writing.

30.7 Headings. The descriptive headings of the various Articles of this Agreement have been inserted for convenience of reference only and are of no significance in the interpretation or construction of this Agreement.

30.8 Multiple Counterparts. This Agreement may be executed in two or more counterparts, each of which is deemed an original but all constitute one and the same instrument.

30.9 Amendment. The Parties may by mutual agreement amend this Agreement by a written instrument duly executed by all the Parties. Such amendment shall become effective and a part of this Agreement upon satisfaction of all Applicable Laws and Regulations.

30.10 Modification by the Parties. The Parties may by mutual agreement amend the Appendices to this Agreement by a written instrument duly executed by the Parties. Such amendment shall become effective and a part of this Agreement upon satisfaction of all Applicable Laws and Regulations.

- 30.11 Reservation of Rights.** FERC-jurisdictional Transmission Owners and the CAISO shall have the right to make a unilateral filing with FERC to modify this Agreement with respect to any rates, terms and conditions, charges, classifications of service, rule or regulation under section 205 or any other applicable provision of the Federal Power Act and FERC's rules and regulations thereunder, and Interconnection Customer shall have the right to make a unilateral filing with FERC to modify this Agreement pursuant to section 206 or any other applicable provision of the Federal Power Act and FERC's rules and regulations thereunder; provided that another Party shall have the right to protest any such filing by the other Party and to participate fully in any proceeding before FERC in which such modifications may be considered. Nothing in this Agreement shall limit the rights of the Parties or of FERC under sections 205 or 206 of the Federal Power Act and FERC's rules and regulations thereunder, except to the extent that the Parties otherwise mutually agree as provided herein. Notwithstanding the foregoing, IID shall not be subject, without its mutual consent, to a modification of its rights and obligations under this Agreement through a unilateral filing by another Party with FERC and, as applied to IID, the Effective Date of a modified Agreement shall not commence until the modified Agreement is actually executed by IID, either voluntarily or pursuant to a lawful order issued by FERC in accordance with Sections 210 and 212 of the Federal Power Act.
- 30.12 No Partnership.** This Agreement shall not be interpreted or construed to create an association, joint venture, agency relationship, or partnership among the Parties or to impose any partnership obligation or partnership liability upon any Party. No Party shall have any right, power or authority to enter into any agreement or undertaking for, or act on behalf of, or to act as or be an agent or representative of, or to otherwise bind, another Party.
- 30.13 Joint and Several Obligations.** Except as otherwise provided in this Agreement, the obligations of each Transmission Owner, the CAISO and the Interconnection Customer are several, and are neither joint nor joint and several.

[REMAINDER OF PAGE INTENTIONALLY LEFT BLANK]

IN WITNESS WHEREOF, the Parties have executed this Agreement in multiple originals, each of which shall constitute and be an original effective Agreement among the Parties.

Arizona Public Service Company

By: _____
Name: _____
Title: _____
Date: _____

Imperial Irrigation District

By: _____
Name: _____
Title: _____
Date: _____

San Diego Gas & Electric Company

By: _____
Name: _____
Title: _____
Date: _____

California Independent System Operator Corporation

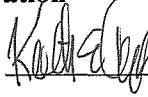
By:  _____
Name: _____
Title: KEITH E. CASEY PH.D. VICE PRESIDENT
MARKET & INFRASTRUCTURE DEVELOPMENT
Date: 5/19/10

Agua Caliente Solar, LLC

By: _____
Name: _____
Title: _____
Date: _____

North Gila River Development, LLC

By: _____
Name: _____
Title: _____
Date: _____

IN WITNESS WHEREOF, the Parties have executed this Agreement in multiple originals, each of which shall constitute and be an original effective Agreement among the Parties.

Arizona Public Service Company

By: _____
Name: _____
Title: _____
Date: _____

Imperial Irrigation District

By: _____
Name: _____
Title: _____
Date: _____

San Diego Gas & Electric Company

By: _____
Name: _____
Title: _____
Date: _____

California Independent System Operator Corporation

By: _____
Name: _____
Title: _____
Date: _____

Agua Caliente Solar, LLC

By: Frank De Rosa
Name: Frank De Rosa
Title: President
Date: May 27, 2010

North Gila River Development, LLC

By: Frank De Rosa
Name: Frank De Rosa
Title: President
Date: May 27, 2010

Appendices

Appendix A-1

Interconnection Facilities, JPP Network Upgrades, and Distribution Upgrades for Phase A of the Interconnection Project

The Generating Facility will have a total rated capacity of 500 MW based on both Phase A and Phase B achieving Commercial Operation. This Appendix A-1 addresses Phase A of the Generating Facility and Appendix A-2 addresses Phase B of the Generating Facility.

1. Phase A of the Generating Facility Description:

Phase A of the Generating Facility is located on private land and consists of a photovoltaic solar field, inverters, a medium voltage collection system, an operations and maintenance building, a 34.5kV/500kV substation and various other facilities. Phase A of the Generating Facility will consist of no more than 290 MW (net) of solar photovoltaic units installed at the site.

The Interconnection Customer Interconnection Facilities include a new substation which will contain two (2) 34.5kV/500kV step-up transformers (“SUTs”). The SUTs are combined through a common high voltage bus that is connected to one single 500 kV interconnection line. Phase A of the Generating Facility is connected to the Transmission Owners’ 500kV switchyard (“Switchyard”) via the single 500kV interconnection line. The substation is located in close proximity to the Switchyard.

2. Point of Interconnection:

The Point of Interconnection for Phase A of the Generating Facility is the Switchyard. See Appendix C – Diagram.

3. Power Injection Limitation at the Point of Interconnection:

The maximum allowable injection of power into the Switchyard at the Point of Interconnection for Phase A of the Generating Facility shall be 290 MW.

4. Point of Change of Ownership:

The Point of Change of Ownership demarcation point of the high voltage conductors and static wires will be the first designed dead end structure outside of the Switchyard fence. The Point of Change of Ownership will be at the line jumper connection point on the Transmission Owners’ dead-ended conductor. Interconnection Customer will provide, per APS specifications, required materials, including foundations, steel structures, insulators, attachment hardware and dead-end connectors to install and terminate conductors at this structure from Switchyard. APS will supply and install conductors to this point of attachment. Interconnection Customer will provide and install materials, including insulators, attachment hardware, conductors, dead-end connectors, and jumper connections, from the Generating Facility substation to the termination point on the dead end structure. See Appendix C – Diagram.

If overhead communication cable is utilized, the interconnection and ownership demarcation point will be a splice point located on the first designed dead-end structure for the high voltage conductor outside of the Switchyard fence. Interconnection Customer will provide required materials for attachment of cable to structures to this point from the Switchyard. APS will provide communication cable to this point. Interconnection Customer will be responsible for providing materials and connection to APS termination at this location.

If underground communication cable is utilized, the interconnection and ownership demarcation point will be a manhole located outside of the Switchyard fence. APS will provide manhole and other materials required to install cable from the Switchyard. Interconnection Customer will be responsible for providing materials and connection to APS termination at this location.

5. Interconnection Facilities:

(a) Interconnection Customer's Interconnection Facilities

The Interconnection Customer's Interconnection Facilities consists of a 34.5/500kV Generating Facility substation, support structures, including the two sided dead end structure, and a generation tie line from the Generating Facility substation to the Point of Change of Ownership with the Transmission Owner's Interconnection Facilities. The Interconnection Customer's Interconnection Facilities also includes all metering equipment required to comply with the CAISO Tariff.

The following is an equipment list from the Interconnection Customer's Interconnection Facilities:

2 – 34.5kV/500kV step up transformers
Revenue meter
Shunt capacitors
Transmission structure at ownership change

(b) Transmission Owners' Interconnection Facilities

The Transmission Owners' Interconnection Facilities consist of the facilities between the Point of Change of Ownership and Point of Interconnection in the Switchyard. This consists of one 500 kV disconnect switch, and a span of 500kV conductor. The protection equipment for Phase A of the Interconnection Project is also included in Transmission Owners' Interconnection Facilities as is the metering equipment for the interconnection.

The following is an equipment list comprising the Transmission Owners' Interconnection Facilities:

Intertie meter
1 500kV, 3000A, Vertical Break Switch
Conductor
Relays

6. JPP Network Upgrades:

(a) Switchyard

APS will design and construct the new 500kV Switchyard. The Switchyard will be designed as a breaker-and-a-half configuration to accommodate future plans of the Transmission Owners and

potential future third-party generation developers. Initially, three 500kV breakers and supporting bus work and structures will be built to accommodate the line terminations from (i) Hassayampa, (ii) North Gila and (iii) the Generating Facility. This initial phase of the Switchyard will include 500kV bus work and disconnect switches to limit outages for future installations.

The Switchyard will also include a control enclosure for the housing of the critical protective relaying and the Supervisory Control and Data Acquisition (SCADA) system. The control room building will include sufficient battery capacity to reliably operate the Switchyard as part of the interconnected Transmission System. Redundant communication will be provided by a new 100-foot microwave tower constructed to support sufficient dishes and antenna to provide reliable integration of the Generating Facility into the APS communications network. No fiber optic lines are planned for Phase A of the Interconnection Project.

The Switchyard site will be secured with a minimum 7-foot tall, chain link metal-fabric security fence with 1-foot barbed wire or razor wire on top.

The following is an equipment list from the Switchyard portion of the JPP Network Upgrades:

Breakers - 3 500kV, 3000A, 63kA

Switches - 10 500kV, 3000A, Vertical Break

1 500kV 3000A, Vertical Reach

Current Transformers (CTs) - 3 500kV, Extended Range Metering Accuracy 1500/5A

CC Voltage Transformers (11)

A fourth breaker will be required when the Switchyard is converted from a ring bus alignment to a breaker and one half arrangement. The timing for this change will be driven by a fifth termination into the Switchyard.

(b) Transmission Line

The transmission interconnection will be a loop-in of the Switchyard to the existing Hassayampa – North Gila #1 500 kV line with the end points being new turning structures located within the existing 500kV line rights-of-way and the dead-end structures located within the Switchyard.

The following is an equipment/material list from the transmission line portion of the JPP Network Upgrades:

2 500kV Lattice Tower structures

Conductor

7. Stand-Alone JPP Network Upgrades: None

8. Transmission Owners' Interconnection Facilities and JPP Network Upgrade Cost Summary:

Cost Estimate (2010 dollars)

Element	Cost	Transmission Owner Share		
		APS	IID	SDG&E
Transmission Owners' Interconnection Facilities				
500kV conductor tie line	611,000	0	0	0
Disconnect Switches	150,000	0	0	0
Protection Equipment	400,000	0	0	0
Contingency	232,000	0	0	0
1) Subtotal	1,393,000	0	0	0
JPP Network Upgrades				
Transmission	1,985,000	218,350	253,683	1,512,967
Switchyard	14,700,000	1,617,000	1,878,660	11,204,340
Telecommunications	75,000	8,250	9,585	57,165
Relay changes at Hassayampa	136,000	14,960	17,381	103,659
Relay changes at North Gila	136,000	14,960	17,381	103,659
Deferred breaker	810,000	89,100	103,518	617,382
Contingency	3,568,000	392,480	455,990	2,719,530
2) Subtotal JPP Network Upgrades	21,410,000	2,355,100	2,736,198	16,318,702
3) Interconnection Project Cost (for cash flow and financial security) (lines 1 & 2)	22,803,000	2,508,330	2,914,223	17,380,447
4) Interconnection Customer Contributions to Network Upgrades (real estate, environmental, and rough grading)	1,173,000	129,030	149,909	894,060
5) Total Network Upgrades (for reimbursement to Agua Caliente Solar, LLC) (lines 2 & 4)	22,583,000	2,484,130	2,886,107	17,212,763

9. Estimate of Monthly Incurred Costs for the Transmission Owners' Interconnection Facilities and JPP Network Upgrades:

An estimate of the monthly incurred costs is shown below.

Month	Estimated Cost by Month
Through April 2010	\$240,168
May 2010	\$0
June 2010	\$0
July 2010	\$486,924
August 2010	\$0
September 2010	\$0
October 2010	\$863,108
November 2010	\$863,108
December 2010	\$863,108
January 2011	\$5,305,720
February 2011	\$5,305,720
March 2011	\$5,305,720
April 2011	\$337,376
May 2011	\$337,376
June 2011	\$337,376
July 2011	\$348,120
August 2011	\$348,120
September 2011	\$348,120
October 2011	\$119,108
November 2011	\$119,108
December 2011	\$119,108
January 2012	\$1,155,672
Total	\$22,803,000

10. Invoicing and JPP Network Upgrade Repayment:

Invoices issued by APS on behalf of the Transmission Owners pursuant to Articles 12.1 and 12.2 of this Agreement for Phase A of the Generating Facility shall include the cumulative balance invoiced to date for the JPP Network Upgrades (including the actual costs for Network Upgrades incurred under the E&P Agreement) and the allocation of such balance to the Ownership Interests.

Within thirty (30) Calendar Days of the Commercial Operation Date for a Project Phase, APS, on behalf of the Transmission Owners, shall provide the Parties with a statement which indicates the

Ownership Share of each of the Transmission Owners in the cost of the Network Upgrades which are to be repaid in accordance with the provisions of Article 11.4.2 of this Agreement.

- (a) SDG&E Share: Interconnection Customer and SDG&E have agreed that SDG&E shall make the repayment provided for in Article 11.4.2 of this Agreement by making a cash payment to Agua Caliente Solar, LLC within sixty (60) Calendar Days of the Commercial Operation Date of each Project Phase.
- (b) APS Share: APS shall make the repayment provided for in Article 11.4.1 of this Agreement to Agua Caliente Solar, LLC in accordance with the terms of this Agreement.
- (c) IID Share: IID shall make the repayment provided for in Article 11.4.3 of this Agreement to Agua Caliente Solar, LLC in accordance with the terms of this Agreement.

11. Distribution Upgrades: NONE

12. Maintenance, Repair, and Replacement Charges:

The Interconnection Customer shall be responsible for actual costs incurred by APS, on behalf of the Transmission Owners, applicable to the maintenance, repair and replacement of the Transmission Owners' Interconnection Facilities, including but not limited to: the 500 kV disconnect switches, protection equipment for the Interconnection Customer's Interconnection Facilities, metering including CTs and PTs and communications equipment and all associated equipment (see Appendix C, Diagram). A good faith non-binding estimate of annual cost, for budgetary purposes only, is:

Estimate = \$ 1,000 per year

\$1,000 annually covers:

- Two inspections per year
- Relay maintenance (estimated at every 4-6 years)
- Disconnect switch maintenance (estimated at every 4-6 years)

Additional actual costs will be charged for:

- Emergency maintenance and repair work
- Replacement of failed or failing equipment

13. Transition from E&P Agreement:

The Parties recognize that some design and long lead-time procurement work for the interconnection of the Large Generating Facility to the JPP was done pursuant to the E&P Agreement entered into by APS, on behalf of the Transmission Owners, and the Interconnection Customer. In order to provide for a smooth transition between work done under the E&P Agreement and this Agreement, the Parties agree :

- (a) **Accounting Transition.** APS, on behalf of the Transmission Owners, shall calculate whether the Interconnection Customer has paid more or less than it owes under the terms of the E&P Agreement as of the Effective Date of this Agreement. If the Interconnection Customer paid more than it owes, APS, on behalf of the Transmission Owners, shall apply a credit to reduce the amount of the payments required under Article 12.1 of this Agreement for the Transmission Owners' Interconnection Facilities and JPP Network Upgrades. If the Interconnection Customer has paid less than it owes, the Interconnection Customer shall pay the amount due as if it were incurred for engineering and procurement work conducted pursuant to this Agreement, in

accordance with Article 12.1 of this Agreement, for the Transmission Owners' Interconnection Facilities and JPP Network Upgrades.

- (b) **Estimate of Total Interconnection Customer Payments.** In accordance with the Milestone Schedule in Appendix B-1, APS, on behalf of the Transmission Owners, shall provide an estimate of the total amount the Interconnection Customer paid under the E&P Agreement as of the Effective Date of this Agreement. This estimate shall be applied as a credit toward the amount of financial security due from the Interconnection Customer pursuant to Article 11.5 of this Agreement and Section 15 of this Appendix A-1 for the Transmission Owners' Interconnection Facilities and JPP Network Upgrades.
- (c) **Letter of Credit.** If the Interconnection Customer has posted a letter of credit or other financial security under the terms of the E&P Agreement, the letter of credit or other financial security shall be returned to Interconnection Customer as of the date the Interconnection Customer posts all of the financial security required in accordance with the terms of Article 11.5 of this Agreement and Section 14 of this Appendix A-1 for the Transmission Owners' Interconnection Facilities and JPP Network Upgrades.

14. Provision of Security:

- (a) **Initial Estimate of Financial Security to be Posted:** The amount available to be drawn under any credit support for the Transmission Owners' Interconnection Facilities and JPP Network Upgrades required to interconnect Phase A of the Generating Facility shall be:

APS Share (11.00%)	\$2,508,330
IID Share (12.78%)	\$2,914,223
Subtotal of APS and IID shares (23.78%)	\$5,422,553
SDG&E Share (76.22%)	\$17,380,447
TOTAL (100%)	\$22,803,000

- (b) **Adjustment for Amounts Paid under E&P Agreement:** The initial estimate of the financial security provided in Section 14(a) of this Appendix A-1 shall be reduced by each of the Transmission Owner's proportional shares of the estimated total Interconnection Customer payments made under the E&P Agreement. When APS, on behalf of the Transmission Owners, provides an estimate of the Interconnection Customer's total payments under the E&P Agreement pursuant to Section 13(b) of this Appendix A-1, it shall provide to the Interconnection Customer and the other Transmission Owners an adjusted estimate of the financial security to be posted.
- (c) **Posting:** The Interconnection Customer shall provide financial security for the Transmission Owners' Interconnection Facilities and JPP Network Upgrades no later than the milestone date specified in Appendix B-1 in accordance with Article 11.5 of this Agreement. With respect to the financial security for the APS and IID shares, Interconnection Customer shall post with APS, on behalf of APS and IID, the adjusted amount for both the APS and IID shares provided pursuant to Section 14(b) of this Appendix A-1 in the form of one security instrument.

With respect to the Interconnection Financial Security for SDG&E, SDG&E already holds Interconnection Financial Security for Phase A of the Generating Facility pursuant to the CAISO

Tariff. As of the date of signing of this Agreement, this security consists of two irrevocable letters of credit for the benefit of Agua Caliente Solar LLC. One of these letters, in the amount of \$5.8 million, has been posted to cover a portion of the Interconnection Customer's share of Network Upgrades. The other, in the amount of \$228,600 has been posted to cover a portion of the Transmission Owners' Interconnection Facilities. The letter of credit for the larger amount currently posted will terminate in accordance with its terms as of October 30, 2010, and the letter of credit for the smaller amount will terminate in accordance with its terms on October 30, 2010. Pursuant to the terms of the CAISO Tariff, these letters of credit must be replaced before they terminate; failure to do so shall provide grounds for termination of this Agreement as provided in Articles 2.3 and 11.5 of this Agreement.

It is possible that the amount of Interconnection Financial Security which the Interconnection Customer was previously required to post may be reduced by order of FERC as a result of litigation pending in Docket No. EL10-15. Regardless of any developments in that proceeding, Interconnection Customer will post the full amount of financial security as required by this Agreement for Phase A of the Generating Facility.

Under this Agreement the total amount the Interconnection Customer shall post no later than the milestone due date specified in Appendix B-1 shall be the adjusted amount for the SDG&E share provided pursuant to Section 14(b) of this Appendix A-1. If Interconnection Financial Security is to be provided before October 31, 2010, SDG&E agrees that the initial Interconnection Financial Security posted with SDG&E shall be replaced with new Interconnection Financial Security posted in accordance with the terms of this Agreement for the total adjusted amount for the SDG&E share provided pursuant to Section 14(b) of this Appendix A-1. SDG&E further agrees that it shall return the original Interconnection Financial Security and shall take no action to enforce its security rights, if any, under the existing Interconnection Financial Security once Interconnection Customer has posted new Interconnection Financial Security in accordance with the terms of this Agreement.

The Parties agree that the Interconnection Customer shall be allowed to make substitutions of the security posted under this Agreement so long as the new security posted is reasonably acceptable to the Transmission Owners, as provided for in Article 11.5 of this Agreement, and in the amount required by this Agreement.

- (d) Reduction of Amount of Security:** Interconnection Customer shall make arrangements for financial security that provide for periodic reduction of the amount of the financial security upon receipt of instructions from APS, acting on behalf of the Transmission Owners. APS, on behalf of the Transmission Owners, shall provide periodic notices of reductions in the amount of the financial security required to be held to the financial institution(s) the Interconnection Customer selects to hold the financial security. APS shall provide such notices to the financial institution holding the security for the APS and IID shares in accordance with the arrangements made by the Interconnection Customer with the financial institution(s), provided, however, that the procedures for providing notice are reasonably acceptable to APS. APS shall also provide notice to SDG&E and IID. Unless otherwise agreed by APS and the Interconnection Customer, APS shall provide notice monthly as payments are made in accordance with Article 12.1 and the financial security shall be reduced proportionately on a dollar-for-dollar by the payments made under this Agreement.

SDG&E agrees that within five (5) Calendar Days of receiving notice of a reduction in the amount of the security pursuant to this section, it shall inform the financial institution that holds the Interconnection Financial Security of the reduction in the amount of the security.

- (e) **Increases to Security Required Due to Change of Cost Estimates.** In the event that APS, on behalf of the Transmission Owners, finds that the cost estimate for Transmission Owner Interconnection Facilities and JPP Network Upgrades provided in this Appendix A-1 has increased, APS, on behalf of the Transmission Owners, shall have the option of (1) offsetting any reduction in the amount of security under Section 14(d) of this Appendix A-1 with the increase in the cost estimate, or (2) notifying Interconnection Customer of the required increase in its financial security to conform to the increased cost estimate.
- (f) **Enforcement of Security for Transmission Owners' Interconnection Facilities and JPP Network Upgrades:** In the event that this Agreement is terminated in accordance with Article 2.3 and APS, on behalf of Transmission Owners, is required to determine the cost responsibility of the Interconnection Customer in accordance with Article 2.4 for Transmission Owners' Interconnection Facilities and JPP Network Upgrades set forth in this Appendix A-1, the Parties agree that in addition to following the procedures set forth elsewhere in this Agreement, the Transmission Owners shall proceed as follows:
- (1) Subject to review and approval by all Transmission Owners, APS shall provide a statement indicating the total cost responsibility of the Interconnection Customer to all Transmission Owners and the allocation of this cost responsibility by Ownership Share ("Statement of Cost Responsibility"). This Statement of Cost Responsibility shall be accompanied by a detailed report which shows how the cost responsibility was determined, including information on all expenditures made on behalf of the Interconnection Customer, payments received, and bills outstanding.
 - (2) If the Interconnection Customer has cost responsibility, upon providing the Statement of Cost Responsibility and accompanying information, APS, on behalf of both APS and IID, shall enforce their financial security rights in proportion to the combined Ownership Interests of APS and IID.
 - (3) If the Interconnection Customer has cost responsibility, upon receipt of the Statement of Cost Responsibility and accompanying information, SDG&E shall enforce its financial security rights in proportion to the Ownership Interest of SDG&E. Within thirty Calendar Days of receipt of the Statement of Cost Responsibility, SDG&E shall provide the funds it receives by enforcing its financial security rights to APS.
 - (4) APS, acting on behalf of the Transmission Owners, shall use the funds provided by enforcing the financial security rights of the Transmission Owners to provide reimbursements and settle accounts proportionately in accordance with the Statement of Cost Responsibility and accompanying report.

15. Reporting Requirements:

Until the In-Service Date for the Transmission Owners' Interconnection Facilities and JPP Network Upgrades for Phase A of the Interconnection Project, Interconnection Customer and APS shall conduct a monthly meeting to coordinate the work related to the Transmission Owners' Interconnection Facilities and JPP Network Upgrades in this Appendix A-1. APS shall submit a monthly written report to the Interconnection Customer in advance of the meeting that provides the following information:

- (a) Progress report on activities;
- (b) Project schedule update; and
- (c) Spending report, including actual expenditures to date and forecasted expenditures in accordance with standard accounting practices.

16. Relationship of Agreement to CAISO Phase II Interconnection Study Report

The Parties acknowledge that this Appendix A-1 contains a list of Interconnection Facilities and JPP Network Upgrades and associated cost estimates that differs in some respects from the list of Interconnection Facilities and JPP Network Upgrades and associated cost estimates in the CAISO Phase II Interconnection Study report. The Parties agree to the descriptions of the Interconnection Facilities and JPP Network Upgrades and associated cost estimates in this Agreement notwithstanding any portions of the CAISO Phase II Interconnection Study report that are inconsistent with the terms of this Agreement; provided, however, that any impacts on, and upgrades required to, IID's Affected System (other than the JPP) shall be addressed in the Affected System Study Agreement and Affected System Construction and Operation Agreement to be executed between Interconnection Customer and IID. The Parties also agree that the cost estimates in this Agreement shall serve as the basis for the determination of the amounts of interconnection financial security required pursuant to Article 11.5, including the Interconnection Financial Security required pursuant to Section 9 of the CAISO's LGIP, rather than the cost estimates set forth in the Phase II Interconnection Study report.

Appendix A-2

Interconnection Facilities, JPP Network Upgrades, and Distribution Upgrades for Phase B of the Interconnection Project

The Generating Facility will have a total rated capacity of 500 MW based on both Phase A and Phase B achieving Commercial Operation. Appendix A-1 addresses Phase A of the Generating Facility and this Appendix A-2 addresses Phase B of the Generating Facility. If interconnection studies determined to be necessary pursuant to Section 4 of Appendix C show a need for additional Interconnection Facilities, JPP Network Upgrades, or Distribution Upgrades for Phase B of the Interconnection Project, this Agreement shall be amended in accordance with the provisions of Section 4 of Appendix C.

1. Phase B of the Generating Facility Description:

The Generating Facility consists of a photovoltaic solar field, inverters, a medium voltage collection system, an operations and maintenance building, and various other facilities. Phase B of the Generating Facility will consist of no more than 210 MW (net) of solar photovoltaic units.

The Interconnection Facilities associated with Phase B of the Generating Facility will include additional 34.5kV/500kV transformers and will be connected to the Switchyard via a single 500kV interconnection line separate from the Phase A 500kV interconnection line.

2. Point of Interconnection:

The Point of Interconnection for Phase B of the Generating Facility is the Switchyard. See Appendix C –Diagram.

3. Power Injection Limitation at the Point of Interconnection:

The maximum allowable injection of power into the Switchyard at the Point of Interconnection for Phase B of the Generating Facility shall be 210 MW.

4. Point of Change of Ownership:

The Point of Change of Ownership demarcation point of the high voltage conductors and static wires will be the first designed dead end structure outside of the Switchyard fence. The Point of Change of Ownership will be at the line jumper connection point on the Transmission Owners' dead-ended conductor. Interconnection Customer will provide, per APS specifications, required materials, including foundations, steel structures, insulators, attachment hardware and dead-end connectors to install and terminate conductors at this structure from Switchyard. APS will supply and install conductors to this point of attachment. Interconnection Customer will provide and install materials, including insulators, attachment hardware, conductors, dead-end connectors, and jumper connections, from the Generating Facility substation to the termination point on the dead end structure. See Appendix C – Diagram.

If overhead communication cable is utilized, the interconnection and ownership demarcation point will be a splice point located on the first designed dead-end structure for the high voltage conductor outside of the Switchyard fence. Interconnection Customer will provide required materials for attachment of cable to structures to this point from the Switchyard. APS will provide communication

cable to this point. Interconnection Customer will be responsible for providing materials and connection to APS termination at this location.

If underground communication cable is utilized, the interconnection and ownership demarcation point will be a manhole located outside of the Switchyard fence. APS will provide manhole and other materials required to install cable from the Switchyard. Interconnection Customer will be responsible for providing materials and connection to APS termination at this location.

5. Interconnection Facilities:

(a) Interconnection Customer's Interconnection Facilities.

The Interconnection Customer's Interconnection Facilities consist of additional 34.5/500 kV transformers and a generation tie line from the Generating Facility substation to the Point of Change of Ownership with the Transmission Owner's Interconnection Facilities. The Interconnection Customer's Interconnection Facilities also includes all metering equipment, if any, required for compliance with the CAISO Tariff.

The following is an equipment list from the Interconnection Customer's Interconnection Facilities:

34.5kV/500kV step up transformers
Revenue meter
Shunt capacitors
Transmission structure at ownership change

(b) Transmission Owners' Interconnection Facilities

The Transmission Owners' Interconnection Facilities consist of the facilities between the Point of Change of Ownership and Point of Interconnection in the Switchyard. This consists of one 500 kV disconnect switch, and a span of 500kV conductor. The protection equipment for Phase B of the Interconnection Project is also included in Transmission Owners' Interconnection Facilities as are the metering equipment for the interconnection.

The following is an equipment list from the Transmission Owners' Interconnection Facilities:

Intertie meter
3 500kV, 3000A, Vertical Break Switches
Conductor
Relays

6. JPP Network Upgrades:

APS will design and construct an additional line termination in the new 500kV Switchyard, which will be constructed for Phase A of the Interconnection Project.

The following is an equipment list from the Switchyard portion of the JPP Network Upgrades:

Breakers - 1 500kV, 3000A, 63kA
Switches - 2 500kV, 3000A, Vertical Break

A second breaker will be required when the Switchyard is converted from a ring bus alignment to a breaker and one half arrangement. The timing for this change will be driven by a fifth termination into the Switchyard.

7. Stand-Alone JPP Network Upgrades: None

8. Transmission Owners' Interconnection Facilities and JPP Network Upgrades Cost Summary:

Cost Estimate (2010 dollars)

Element	Cost	Transmission Owner Share		
		APS	IID	SDG&E
Transmission Owners' Interconnection Facilities				
500kV conductor tie line	657,000	0	0	0
Disconnect Switches	150,000	0	0	0
Protection Equipment	375,000	0	0	0
Contingency	236,000	0	0	0
1) Subtotal	1,418,000	0	0	0
JPP Network Upgrades				
Switchyard Breaker	899,000	98,890	114,852	685,218
Deferred breaker	810,000	89,100	103,518	617,382
Contingency	342,000	37,620	43,708	260,672
2) Subtotal	2,051,000	225,610	262,118	1,563,272
3) Total Interconnection Project Cost (for cash flow and financial security) (lines 1 & 2)	3,469,000	381,590	443,338	2,644,072
4) Total Network Upgrades (for reimbursement to North Gila River Development, LLC) (line 2)	2,051,000	225,610	262,118	1,563,272

9. Estimate of Monthly Incurred Costs for the Transmission Owners' Interconnection Facilities and JPP Network Upgrades:

An estimate of the monthly incurred costs is shown below.

Month	Estimated Cost by Month
Oct 2011	26,416
Nov 2011	26,416
Dec 2011	26,416

Jan 2012	609,160
Feb 2012	609,160
Mar 2012	609,160
April 2012	465,980
May 2012	465,980
June 2012	465,980
July 2012	47,180
Aug 2012	47,180
Sept 2012	47,180
Oct 2012	11,396
Nov 2012	11,396
Total	3,469,200

10. Invoicing and JPP Network Upgrade Repayment:

Invoices issued by APS on behalf of the Transmission Owner pursuant to Articles 12.1 and 12.2 of this Agreement for Phase B of the Generating Facility shall include the cumulative balance invoiced to date for the JPP Network Upgrades and the allocation of such balance to the Ownership Interests.

Within thirty (30) Calendar Days of the Commercial Operation Date for a Project Phase, APS, on behalf of the Transmission Owners, shall provide the Parties with a statement which indicates the Ownership Share of each of the Transmission Owners in the cost of the Network Upgrades which are to be repaid in accordance with the provisions of Article 11.4.2 of this Agreement.

- (a) SDG&E Share: Interconnection Customer and SDG&E have agreed that SDG&E shall make the repayment provided for in Article 11.4.2 of this Agreement by making a cash payment to North Gila River Development, LLC within sixty (60) Calendar Days of the Commercial Operation Date of each Project Phase.
- (b) APS Share: APS shall make the repayment provided for in Article 11.4.1 of this Agreement to North Gila River Development, LLC in accordance with the terms of this Agreement.
- (c) IID Share: IID shall make the repayment provided for in Article 11.4.3 of this Agreement to North Gila River Development, LLC in accordance with the terms of this Agreement.

11. Distribution Upgrades: None

12. Maintenance, Repair, and Replacement Charges:

The Interconnection Customer shall be responsible for actual costs incurred by APS, on behalf of the Transmission Owners, applicable to the maintenance, repair and replacement of the Transmission Owners' Interconnection Facilities, including but not limited to: the 500 kV disconnect switches, protection equipment for the Interconnection Customer's Interconnection Facilities, metering including CTs and PTs and communications equipment and all associated equipment (see Appendix C, Diagram). A good faith non-binding estimate of annual cost, for budgetary purposes only, is:

Estimate = \$ 1,000 per year

\$1,000 annually covers:

- Two inspections per year
- Relay maintenance (estimated at every 4-6 years)
- Disconnect switch maintenance (estimated at every 4-6 years)

Additional actual costs will be charged for:

- Emergency maintenance and repair work
- Replacement of failed or failing equipment

13. Provision of Security:

(a) Financial Security to be Posted: The amount available to be drawn under any credit support for the Transmission Owners' Interconnection Facilities and JPP Network Upgrades required to interconnect Phase B of the Generating Facility shall be:

APS Share (11.00%)	\$381,612	
IID Share (12.78%)	\$443,364	
Subtotal of APS and IID Shares (23.78%)		\$824,976
SDG&E Share (76.22%)		\$2,644,224
TOTAL (100%)		\$3,469,200

(b) Posting: The Interconnection Customer shall provide financial security for the Transmission Owners' Interconnection Facilities and JPP Network Upgrades no later than the milestone due date specified in Appendix B-2 in accordance with Article 11.5 of this Agreement. With respect to the financial security for APS and IID shares, Interconnection Customer shall post with APS, as Operating Agent, the amount for both the APS and IID shares specified in Section 13(a) of this Appendix A-2 in the form of one security instrument.

With respect to the Interconnection Financial Security for SDG&E, the amount posted shall be the amount SDG&E is to provide pursuant to Section 13(a) of this Appendix A-2. The Interconnection Financial Security shall be posted in accordance with the terms of the CAISO tariff.

The Parties agree that the Interconnection Customer shall be allowed to make substitutions of the security posted under this Agreement so long as the new security posted is reasonably acceptable to the Transmission Owners, as provided for in Article 11.5 of this Agreement, and in the amount required by this Agreement.

(c) Reduction of Amount of Security: Interconnection Customer shall make arrangements for financial security that provide for periodic reduction of the amount of the financial security upon receipt of instructions from APS, acting on behalf of the Transmission Owners. APS, on behalf of the Transmission Owners, shall provide periodic notices of reductions in the amount of the financial security required to be held to the financial institution(s) the Interconnection Customer selects to hold the financial security. APS shall provide such notices to the financial institution holding the security for the APS and IID shares in accordance with the arrangements made by the Interconnection Customer with the financial institution(s), provided, however, that the procedures for providing notice are reasonably

acceptable to APS. APS shall also provide notice to SDG&E and IID. Unless otherwise agreed by APS and the Interconnection Customer, APS shall provide notice monthly as payments are made in accordance with Article 12.1 and the financial security shall be reduced proportionately on a dollar-for-dollar by the payments made under this Agreement.

SDG&E agrees that within five (5) Calendar Days of receiving notice of a reduction in the amount of the security pursuant to this section, it shall inform the financial institution that holds the Interconnection Financial Security of the reduction in the amount of the security.

- (d) Increases to Security Required Due to Change of Cost Estimates.** In the event that APS, on behalf of the Transmission Owners, finds that the cost estimate for Transmission Owner Interconnection Facilities and Network Upgrades provided in this Appendix A-2 has increased, APS, on behalf of the Transmission Owners, shall have the option of (1) offsetting any reduction in the amount of security under Section 13(c) of this Appendix A-2 with the increase in the cost estimate, or (2) notifying Interconnection Customer of the required increase in its financial security to conform to the increased cost estimate.
- (e) Enforcement of Security for Transmission Owners' Interconnection Facilities and JPP Network Upgrades:** In the event that this Agreement is terminated in accordance with Article 2.3 and APS, on behalf of Transmission Owners, is required to determine the cost responsibility of the Interconnection Customer in accordance with Article 2.4 for Transmission Owners' Interconnection Facilities and JPP Network Upgrades set forth in this Appendix A-2, the Parties agree that in addition to following the procedures set forth elsewhere in the Agreement, the Transmission Owners shall proceed as follows:
- (1)** Subject to review and approval by all Transmission Owners, APS shall provide a statement indicating the total cost responsibility of the Interconnection Customer to all Transmission Owners and the allocation of this cost responsibility by Ownership Share ("Statement of Cost Responsibility"). This Statement of Cost Responsibility shall be accompanied by a detailed report which shows how the cost responsibility was determined, including information on all expenditures made on behalf of the Interconnection Customer, payments received, and bills outstanding.
 - (2)** If the Interconnection Customer has cost responsibility, upon providing the Statement of Cost Responsibility and accompanying information, APS, on behalf of both APS and IID, shall enforce their financial security rights in proportion to the combined Ownership Interests of APS and IID.
 - (3)** If the Interconnection Customer has cost responsibility, upon receipt of the Statement of Cost Responsibility and accompanying information, SDG&E shall enforce its financial security rights in proportion to the Ownership Interest of SDG&E. Within thirty (30) Calendar Days of receipt of the Statement of Cost Responsibility, SDG&E shall provide the funds it receives by enforcing its financial security rights to APS.
 - (4)** APS, acting on behalf of the Transmission Owners, shall use the funds provided by enforcing the financial security rights of the Transmission Owners to provide reimbursements and settle accounts proportionately in accordance with the Statement of Cost Responsibility and accompanying report.

14. Reporting Requirements:

From the date upon which authorization to proceed is provided pursuant to Article 5.1.1 for Phase B of the Generating Facility until the In-Service Date for Phase B of the Interconnection Project, Interconnection Customer and APS shall conduct a monthly meeting to coordinate the work related to

the Transmission Owners' Interconnection Facilities and JPP Network Upgrades in this Appendix A-2. APS shall submit a monthly written report to the Interconnection Customer in advance of the meeting that provides the following information:

- (a) Progress report on activities;
- (b) Project schedule update; and
- (c) Spending report, including actual expenditures to date and forecasted expenditures in accordance with standard accounting practices.

Appendix A-3

SDG&E Network Upgrades for Phase B of the Interconnection Project

If the interconnection studies determined to be necessary pursuant to Section 4 of Appendix C identify additional Network Upgrades to be constructed by SDG&E, the Parties shall amend this Agreement to incorporate provisions for those Network Upgrades into this Appendix A-3.

Appendix B-1

Milestones for Interconnection Facilities and JPP Network Upgrades for Phase A of the Interconnection Project

The Interconnection Customer has selected the Standard Option provided for in Article 5.1. Transmission Owners shall design, procure, and construct Transmission Owner's Interconnection Facilities and JPP Network Upgrades, using Reasonable Efforts to complete Transmission Owner's Interconnection Facilities and JPP Network Upgrades by the dates set forth in this Appendix B-1, Milestones. Milestone dates after October 1, 2010 may be adversely affected by an Effective Date later than October 1, 2010.

Milestones for Interconnection Facilities and JPP Network Upgrades for Phase A of the Interconnection Project	Responsible Party	Due Date
Begin design, permitting and land acquisition for line cut-in facilities	Operating Agent	E&P Agreement
Begin major equipment procurement specifications	Operating Agent	E&P Agreement
Complete planning and equipment specifications	Operating Agent	E&P Agreement
Begin above grade design	Operating Agent	E&P Agreement
Begin below grade design	Operating Agent	E&P Agreement
Submit estimate of Interconnection Customer payments under E&P Agreement and financial security posting requirements	Operating Agent	9/15/2010 or within 5 Calendar Days of Effective Date, if later
Submit interconnection financial security (Sections 5.6.4 and 11.5)	Interconnection Customer	Within 10 Calendar Days of receipt of financial security requirements
Complete transmission line and tower design	Operating Agent	5/31/10
Complete above grade design	Operating Agent	7/30/2010
Additional long lead time material procurement: Breakers, Switches	Operating Agent	Q2 2010
Submit written notice to proceed for procurement of towers	Interconnection Customer	6/1/2010
Complete below grade design	Operating Agent	8/11/10

Submit written authorization to APS to proceed with the construction of the Switchyard portion of Transmission Owners' 500kV Network Upgrades (Section 5.1.1 Standard Option)	Interconnection Customer	10/1/2010 or within 15 Calendar Days of Effective Date, if later
Submit written authorization to APS to proceed with the construction of the transmission line portion of Transmission Owners' 500kV JPP Network Upgrades (section 5.1.1 Standard Option)	Interconnection Customer	11/15/2010 or within 15 Calendar Days of Effective Date, if later
Complete land services/environmental	Operating Agent	12/27/2010
Complete installation of towers and tie line	Operating Agent	3/1/2011
Complete below grade work	Operating Agent	3/1/2011
Complete major equipment procurement	Operating Agent	6/13/2011
Complete material deliveries	Operating Agent	7/11/2011
Complete communications work	Operating Agent	8/22/2011
Complete above grade work	Operating Agent	11/2/2011
Complete control work	Operating Agent	11/3/2011
Line Drop Complete	Operating Agent	11/1/2011
Testing/Commissioning Complete	Operating Agent	12/1/2011
In-Service Date for JPP Network Upgrades and Transmission Owners' Interconnection Facilities	Operating Agent	12/1/2011
In-Service Date for Interconnection Customer's Interconnection Facilities	Interconnection Customer	12/1/2011
Initial Synchronization Date	Interconnection Customer	12/15/2011
Commercial Operation Date (COD) of Phase A of Generating Facility	Interconnection Customer	6/30/2014
Release date of financial security provided for in Appendix A-1 for Phase A of the Interconnection Project	Operating Agent	30 Calendar Days after COD

Early Operations

Given the modular nature of a photovoltaic solar facility, which is constructed in 1-2 MW Project Blocks, various stages of the Generating Facility will be added after Trial Operation of a Project Phase and will commence Commercial Operation prior to the Commercial Operation Date for the Project Phase. From the Initial Synchronization Date for each Project Phase, it is estimated that an additional 8-12 MW will be tested and commence Commercial Operation each month until the entire Project Phase is completed. Following the Initial Synchronization Date, Interconnection Customer will notify APS and CAISO at least ten (10) Calendar Days and not more than thirty (30) Calendar Days prior to the date each portion of the Project Phase with a generation capacity of at least one (1) MW but not more than twenty (20) MW will be completed and commence operation.

Further details regarding early operations will be included in an implementation plan. The proposed implementation plan shall be prepared by the Interconnection Customer and shall be submitted to APS, on behalf of Transmission Owners, and the CAISO for approval at least one-hundred twenty (120) Calendar Days prior to the scheduled In-Service Date for the Transmission Owners' Interconnection Facilities and JPP Network Upgrades for Phase A of the Interconnection Project. CAISO and APS, on behalf of Transmission Owners, shall provide written comments regarding the proposed implementation plan within thirty (30) Calendar Days of receipt. Interconnection Customer, CAISO, and APS shall work in good faith to finalize the implementation plan no later than sixty (60) Calendar Days prior to the scheduled In-Service Date.

Appendix B-2

Milestones for Interconnection Facilities and JPP Network Upgrades for Phase B of the Interconnection Project

The Interconnection Customer has selected the Standard Option provided for in Article 5.1. Transmission Owners shall design, procure, and construct Transmission Owner's Interconnection Facilities and JPP Network Upgrades, using Reasonable Efforts to complete Transmission Owner's Interconnection Facilities and JPP Network Upgrades by the dates set forth in this Appendix B-2, Milestones. Milestone dates after October 1, 2010 may be adversely affected by an Effective Date later than October 1, 2010.

Milestones for Interconnection Facilities and JPP Network Upgrades for Phase B of the Interconnection Project	Responsible Party	Due Date
Submit written notification to Parties of the intended Balancing Authority for Phase B of the Generating Facility	Interconnection Customer	3/15/2011
Complete review of all available studies to determine whether there is a need for additional interconnection studies regarding the possible impacts of Phase B of the Generating Facility on the CAISO Transmission System.	CAISO	4/15/2011
If additional interconnection studies are needed, provide notification to the Parties of the process for having such additional interconnection studies done in accordance with the applicable interconnection process.	CAISO	Note (1)
Complete review of all available studies to determine whether there is a need for additional Affected System Study regarding the possible impacts of Phase B of the Generating Facility on IID's non-JPP facilities.	IID	5/15/ 2011
If additional Affected System Study is needed, provide notification to the Parties of the process for having such additional studies done.	IID	Note (1)
Submit written authorization to proceed with long lead time material procurement and submit procurement financial security	Interconnection Customer	10/1/2011
Begin long lead time material procurement: Breakers, Switches	Operating Agent	1/15/2012
Submit written authorization to APS to proceed with the construction of Phase B of the Interconnection Project and submit construction financial security (Sections 5.6.4 and 11.5)	Interconnection Customer	5/1/2012
In-Service Date for JPP Network Upgrades and Transmission Owners' Interconnection Facilities (conditioned on available outage period)	Operating Agent	10/15/2012
In-Service Date for Interconnection Customer's Interconnection	Interconnection Customer	10/15/2012

Facilities		
Initial Synchronization Date	Interconnection Customer	11/1/2012
Commercial Operation Date (COD) of Phase B of the Generating Facility	Interconnection Customer	6/15/2015
Release date of financial security provided for in Appendix A-2 for Phase B of the Interconnection Project	Operating Agent	30 Calendar Days after COD

Note 1: If additional studies are required pursuant to Section 4 of Appendix C, the Parties will work together to amend this Agreement to modify this Appendix B-2 to establish a new schedule for Phase B of the Interconnection Project that is reasonably acceptable to all Parties.

Early Operations

Given the modular nature of a photovoltaic solar facility, which is constructed in 1-2 MW Project Blocks, various stages of the Generating Facility will be added after Trial Operation of a Project Phase and will commence Commercial Operation prior to the Commercial Operation Date for the Project Phase. From the Initial Synchronization Date for each Project Phase, it is estimated that an additional 8-12 MW will be tested and commence Commercial Operation each month until the entire Project Phase is completed. Following the Initial Synchronization Date, Interconnection Customer will notify APS and CAISO at least ten (10) Calendar Days and not more than thirty (30) Calendar Days prior to the date each portion of the Project Phase with a generation capacity of at least one (1) MW but not more than twenty (20) MW will be completed and commence operation.

Further details regarding early operations will be included in an implementation plan. The proposed implementation plan shall be prepared by the Interconnection Customer and shall be submitted to APS, on behalf of Transmission Owners, and the CAISO for approval at least one hundred twenty (120) Calendar Days prior to the scheduled In-Service Date for the Transmission Owners' Interconnection Facilities and JPP Network Upgrades for Phase B of the Interconnection Project. CAISO and APS, on behalf of Transmission Owners, shall provide written comments regarding the proposed implementation plan within thirty (30) Calendar Days of receipt. Interconnection Customer, CAISO, and APS shall work in good faith to finalize the implementation plan no later than sixty (60) Calendar Days prior to the scheduled In-Service Date.

Appendix B-3

Milestones for SDG&E Network Upgrades for Phase B of the Interconnection Project

If the interconnection studies determined to be necessary pursuant to Section 4 of Appendix C identify additional Network Upgrades to be constructed by SDG&E, the Parties shall amend this Agreement to incorporate milestones for the construction of those Network Upgrades into this Appendix B-3.

Appendix C

Interconnection Details

1. Description of the Large Generating Facility

The Generating Facility consists of a photovoltaic solar field, inverters, a medium voltage collection system, an operations and maintenance building, a 34.5kV/500kV substation and various other facilities. Phase A of the Generating Facility will consist of no more than 290 MW (net) of solar photovoltaic units installed at the site. Phase B of the Generating Facility will consist of no more than 210 MW (net). The Generating Facility will have with a total rated capacity of 500 MW based on both Phase A and Phase B achieving Commercial Operation.

Phase A of the Generating Facility will be interconnected to the Switchyard via a gen-tie line on the diagram below and Phase B of the Generating Facility will be interconnected to the Switchyard via a separate gen-tie line on the diagram.

2. Diagram Illustrating the Facilities at the Switchyard

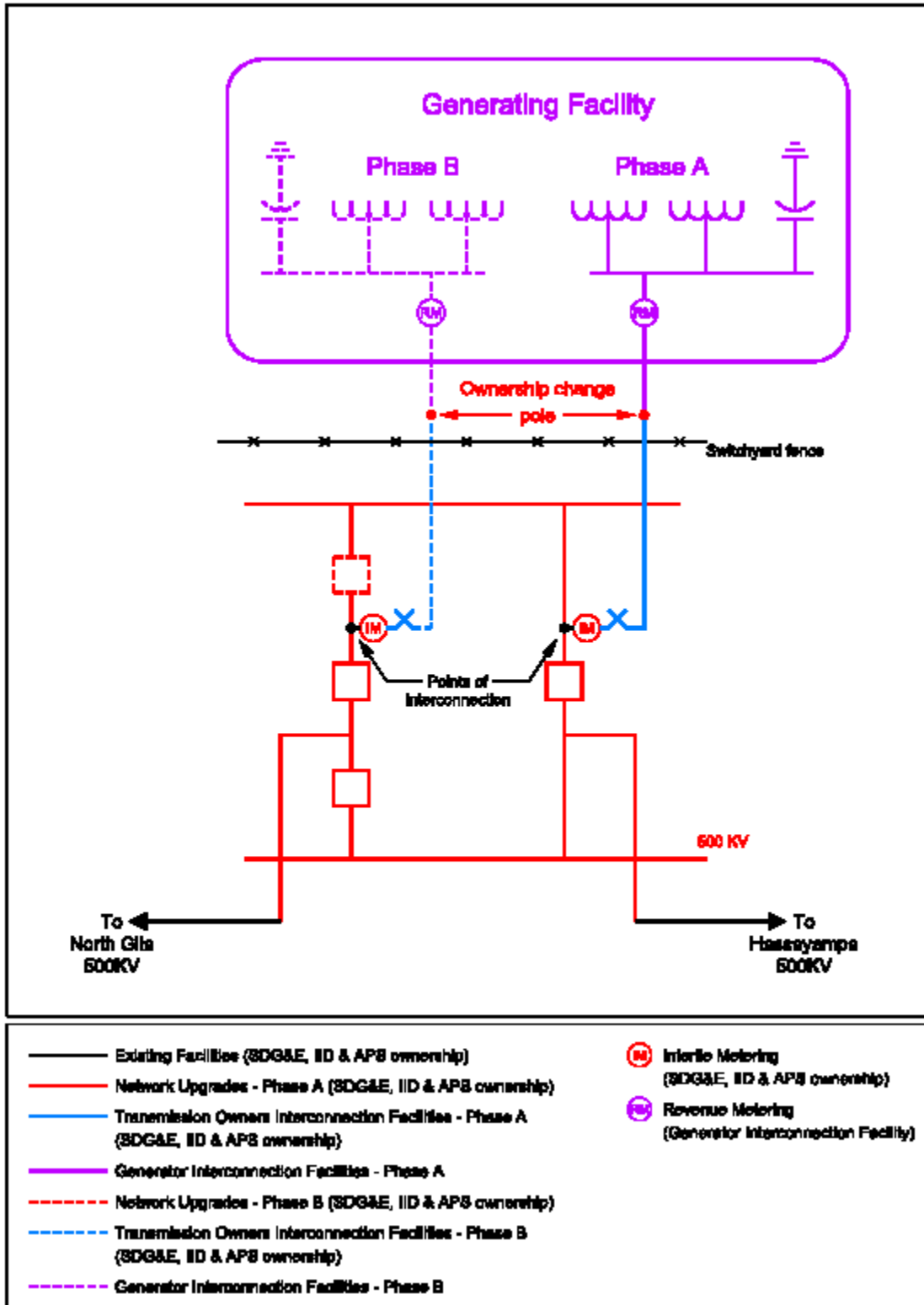

3. Balancing Authority Requirements:

If a Project Phase is to be under a Balancing Authority other than the APS's Balancing Authority, all executed agreements between Interconnection Customer and the other Balancing Authority relating to the Large Generating Facility shall be shared with APS, as the Operating Agent for the JPP.

4. Additional Conditions for Construction of Phase B of the Interconnection Project:

No later than March 15, 2011, Interconnection Customer shall notify the other Parties in writing of the intended Balancing Authority for Phase B of the Generating Facility. Construction of Phase B of the Interconnection Project shall not commence nor shall delivery of energy from Phase B of the Generating Facility to the Transmission System commence until all of the following actions have occurred:

- (a) Interconnection Customer will provide written authorization to APS to proceed with the construction of the Switchyard portion of Transmission Owners' 500kV Network Upgrades for Phase A of the Interconnection Project and Phase A of the Interconnection Project has not otherwise been suspended or terminated.
- (b) Within thirty (30) Calendar Days following receipt of the notice of intended Balancing Authority, the CAISO will review all available studies and determine whether there is a need for additional interconnection studies regarding the possible impacts of Phase B of the Generating Facility on the Transmission System.
- (c) If the CAISO concludes that there is a need for additional interconnection studies, within thirty (30) Calendar Days following receipt of the notice of intended Balancing Authority the CAISO will notify the Parties of the process for having CAISO conduct such additional interconnection studies, which may include the submittal by the Interconnection Customer of an additional Interconnection Request to the CAISO for Phase B of the Generating Facility in accordance with the CAISO's LGIP. Either in accordance with the CAISO's LGIP for a separate Interconnection Request for Phase B of the Generating Facility or pursuant to any other interconnection study process as specified by the CAISO or otherwise determined by FERC for the jurisdictional public utilities which are Parties to this Agreement, the CAISO and Interconnection Customer will enter into an interconnection study agreement under which the Interconnection Customer will agree to pay the reasonable and actual costs of the interconnection studies identified by the CAISO as needed, plus any study deposits required by the CAISO.
- (d) If the CAISO concludes on the basis of the studies provided for in Section 4(c) of this Appendix C that construction of additional facilities is required on the CAISO-controlled grid, this Agreement shall be amended to provide for construction of such facilities and for repayment of the cost of any such facilities that are Network Upgrades in accordance with the principles set forth in Article 11.4.2.
- (e) Within thirty (30) Calendar Days of its receipt of the notice provided by the CAISO in accordance with Section 4(c) of this Appendix C, IID shall determine whether there is a need for an additional Affected System Study regarding the possible impacts of Phase B of the Generating Facility on IID's Transmission System, other than IID's share of the JPP.
- (f) If IID concludes that there is a need for such an additional Affected System Study, IID shall notify the Parties of the process for having IID conduct such an additional Affected System Study and Interconnection Customer shall enter into an Affected System Study Agreement for Phase B of the Generating Facility.
- (g) If IID reasonably concludes on the basis of the studies provided for in Section 4(f) of this Appendix C that construction of additional IID Network Upgrades is required, the

Interconnection Customer and IID shall enter into an Affected System Construction and Operation Agreement for Phase B of the Generating Facility.

5. Joint and Several Liability for Entities Comprising Interconnection Customer

Except as otherwise provided, each entity comprising the Interconnection Customer shall be jointly and severally liable for all obligations required of the Interconnection Customer set forth in this Agreement, including all affirmative covenants and all monetary obligations, the latter of which includes the financing of all Interconnection Facilities and Network Upgrades that are required to be financed by the Interconnection Customer in order to accommodate the interconnection of the entire Generating Facility.

6. Representative of Entities Comprising Interconnection Customer

Agua Caliente Solar LLC and North Gila River Development, LLC shall appoint a single spokesperson, who shall serve as the Interconnection Customer's authorized agent and representative for purposes of administering this Agreement. The designated single spokesperson shall be a single point of contact for CAISO and Transmission Owners and will represent Interconnection Customer for notice purposes and all other communications between and among CAISO, Transmission Owners and Interconnection Customer. Except as otherwise provided, any invoices or refunds due to one of the entities comprising the Interconnection Customer by the Transmission Owners shall be made to the designated single spokesperson. The single spokesperson shall bear all responsibility for disseminating notices, communications and all interactions among the entities comprising the Interconnection Customer, and each entity comprising the Interconnection Customer hereby waives any right to individual notice or communication from CAISO or the Transmission Owners. The CAISO and the Transmission Owners will not be obligated to act on any instructions from either of the entities comprising the Interconnection Customer who is not the designated single spokesperson. The actions of the single spokesperson and his or her representations to CAISO and the Transmission Owners shall be binding upon the Interconnection Customer and each entity comprising the Interconnection Customer. This provision shall be of no further force and effect upon either the division of the Agreement obligations, as set forth in Section 7 of this Appendix C or the termination of Phase B of the Generating Facility, as set forth in Section 8 of this Appendix C.

7. Division of Agreement Obligations.

If the conditions for construction for Phase B of the Interconnection Project set out in Section 4 of this Appendix C have been met, the Interconnection Customer shall determine whether obtaining financing for the Generating Facility on commercially reasonable terms will require separate Large Generator Interconnection Agreements (LGIAs) for Phase A of the Generating Facility and Phase B of the Generating Facility. If the Interconnection Customer determines that separate LGIAs are needed, the Parties agree they shall negotiate in good faith to: (1) amend this Agreement solely for the purpose of making it apply only to Phase A of the Generating Facility and Phase A of the Interconnection Project; and (2) enter into a second LGIA for Phase B of the Generating Facility on terms that are substantially similar in all material relevant respects to this Agreement and to the amended version of this Agreement for Phase A of the Generating Facility. In such event, the joint and several liability set out in Section 5 of this Appendix C shall cease.

8. Termination of Phase B of the Generating Facility.

In addition to the termination right provided in Article 2.3 of this Agreement, and subject to its terms, those of Article 2.4 of the Agreement and any applicable Tariff, North Gila River Development, LLC may terminate this Agreement as it relates to Phase B of the Generating Facility provided the right to

terminate Phase B of the Generating Facility is conditioned on an obligation to fund the Network Upgrades set forth in Appendix A-2 in the event such termination constitutes a Material Modification of the Interconnection Request and is necessary to avoid adversely impacting lower queued interconnection customers. In the event North Gila River Development, LLC elects to terminate this Agreement as it relates to Phase B of the Generating Facility, this Agreement shall be amended accordingly so as to remove all references, terms and conditions pertaining to Phase B of the Generating Facility. Such termination shall leave unaffected the terms and conditions in this Agreement with respect to Phase A of the Generating Facility.

Appendix D

Security Arrangements Details

Infrastructure security of Transmission System equipment and operations and control hardware and software is essential to ensure day-to-day Transmission System reliability and operational security. FERC will expect all transmission providers, market participants, and Interconnection Customers interconnected to the Transmission System to comply with the recommendations offered by the President's Critical Infrastructure Protection Board and, eventually, best practice recommendations from the electric reliability authority. All public utilities will be expected to meet basic standards for system infrastructure and operational security, including physical, operational, and cyber-security practices.

If the Interconnection Customer selects the CAISO as the Balancing Authority for a Project Phase, for that Project Phase the Interconnection Customer shall meet the requirements for security implemented pursuant to the CAISO Tariff, including the CAISO's standards for information security posted on the CAISO's internet web site at the following internet address: <http://www.aiso.com/pubinfo/info-security/index.html>.

Appendix E

Commercial Operation Date

This Appendix E is a part of the Agreement.

[Date]

**Arizona Public Service Co.
Attn: Manager of Interconnection Development
MS 2259
P.O. Box 53999
Phoenix, AZ 85072-3999**

Mr. Stephen Ruty
Manager of Grid Assets
California Independent System Operator Corporation
151 Blue Ravine Road
Folsom, CA 95630

Mr. Robert Kott
Manager of Model & Contract Implementation
California Independent System Operator Corporation
151 Blue Ravine Road
Folsom, CA 95630

Re: Commercial Operation Date of Phase ___ of the Generating Facility

Dear _____:

On **[Date]** **[Interconnection Customer]** completed the last Project Block of Phase ___ of the Generating Facility. This letter confirms that the Commercial Operation Date of Phase ___ of the Generating Facility, is **[Date plus one day]** and that **[Entity Comprising Interconnection Customer]** provided the CAISO's operations personnel advance notice of this intended Commercial Operation Date no less than five Business Days prior to that date.

Thank you.

[Signature]

[Interconnection Customer Representative]

Appendix F

Addresses for Delivery of Notices and Billings

Notices:

Operating Agent:

Arizona Public Service Company
Attn: Manager of Interconnection Development
MS 2259
P.O. Box 53999
Phoenix, AZ 85072-3999

Transmission Owners:

Arizona Public Service Company
Attn: Manager of Interconnection Development
MS 2259
P.O. Box 53999
Phoenix, AZ 85072-3999

Imperial Irrigation District
Attention: Inter-Connect Transmission Contract Administrator
333 East Barioni Boulevard
PO Box 937
Imperial, CA 92251

San Diego Gas & Electric Company
Attn: Transmission Planning Manager
8316 Century Park Court; CP52A
San Diego, CA 92123-1593

California Independent System Operator Corporation

California ISO
Ms. Judy Brown
151 Blue Ravine Rd.
Folsom, CA 95630

Designated Single Spokesperson for Entities Comprising Interconnection Customer:

Agua Caliente Solar, LLC (Phase A) and North Gila River Development, LLC (Phase B)
Attn: : Jim Filippi, Director of Transmission
353 Sacramento St.
Suite 2100
San Francisco, CA 94111

With a copy to:
NextLight Renewable Power, LLC
Attn: Robert F. Miller, Vice President & General Counsel

353 Sacramento St.
Suite 2100
San Francisco, CA 94111

Billings and Payments:

Operating Agent:

Arizona Public Service Company
Attn: Manager of Interconnection Development
MS 2259
P.O. Box 53999
Phoenix, AZ 85072-3999

Interconnection Customer:

Agua Caliente Solar, LLC (Phase A) and North Gila River Development, LLC (Phase B)
Attn: Controller
353 Sacramento St.
Suite 2100
San Francisco, CA 94111

With a copy to:
NextLight Renewable Power, LLC
Attn: Jim Filippi, Director of Transmission
353 Sacramento St.
Suite 2100
San Francisco, CA 94111

California Independent System Operator Corporation

California ISO
Finance Dept.
Dennis Estrada
151 Blue Ravine Rd.
Folsom, CA 95630

Alternative Forms of Delivery of Notices (telephone, facsimile or email):

Transmission Owners:

Arizona Public Service Company
Attn: Manager, Interconnections Development
MS 2259
P.O. Box 53999
Phoenix, AZ 85072-3999

502 South 2nd Avenue, MS 2259
Phoenix, AZ 85003

Phone: (602) 250-1644
Facsimile: (602) 250-1674
Email: Rex.Stulting@aps.com

Imperial Irrigation District
Attention: Inter-Connect Transmission Contract Administrator
333 East Barioni Boulevard
PO Box 937
Imperial, CA 92251

San Diego Gas & Electric Company
Grid Operations Services Manager
Phone: 619-725-8637
Fax: 619-683-3291

California Independent System Operator Corporation
jbrown@caiso.com

Designated Single Spokesperson for Entities Comprising Interconnection Customer:

Agua Caliente Solar, LLC (Phase A) and North Gila River Development, LLC (Phase B)
Attn: Jim Filippi
353 Sacramento St.
Suite 2100
San Francisco, CA 94111

Phone: (415) 935-2498
Facsimile: (415) 935-2499
Email: jfilippi@nextlight.com

With a copy to:
NextLight Renewable Power, LLC
Attn: Robert F. Miller, Vice President & General Counsel
353 Sacramento St.
Suite 2100
San Francisco, CA 94111

Phone: (415) 935-2500
Facsimile: (415) 935-2501

For Billings:
Agua Caliente Solar, LLC (Phase A) and North Gila River Development, LLC (Phase B)
Attn: Controller
353 Sacramento St.
Suite 2100
San Francisco, CA 94111

Facsimile: (415) 935-2501
Email: ap@nextlight.com

Interconnection Customer Contact Information Regarding General Operating Issues

(Non Real-Time)

Interconnection Customer shall provide Contact information within 120 days of the expected energization of the Switchyard as part of the implementation plan.

Interconnection Customer Contact Information Regarding Real-Time Operating Issues

(Real-Time 24/7)

Interconnection Customer shall provide Contact information within 120 days of the expected energization of the Switchyard as part of the implementation plan.

Operating Agent Contact Information Regarding General Operating Issues

(Non Real-Time)

Arizona Public Service Company
Attn: Thomas Glock, Power Operations Manager
MS 2260
P.O. Box 53999
Phoenix, AZ 85072-3999

502 South 2nd Avenue, MS 2260
Phoenix, AZ 85003

Phone: APS shall provide within 120 days of the expected energization of the Switchyard
Facsimile: APS shall provide within 120 days of the expected energization of the Switchyard
Email: Thomas.Glock@aps.com

Operating Agent Contact Information Regarding Real-Time Operating Issues

(Real-Time 24/7)

APS Energy Control Center
ECC Supervisor

Transmission Issues

Phone: APS shall provide within 120 days of the expected energization of the Switchyard

Generation Issues

Phone: APS shall provide within 120 days of the expected energization of the Switchyard

Appendix G

Requirements of a Wind Generating Plant

Intentionally Omitted as Inapplicable

Appendix H

Reliability Management System Agreement

RELIABILITY MANAGEMENT SYSTEM AGREEMENT
by and between
[TRANSMISSION OPERATOR]
and
[GENERATOR]

THIS RELIABILITY MANAGEMENT SYSTEM AGREEMENT(the "Agreement"), is entered into this ____ day of _____, _____, by and between _____ (the "Transmission Operator") and _____ (the "Generator").

WHEREAS, there is a need to maintain the reliability of the interconnected electric systems encompassed by the WECC in a restructured and competitive electric utility industry;

WHEREAS, with the transition of the electric industry to a more competitive structure, it is desirable to have a uniform set of electric system operating rules within the Western Interconnection, applicable in a fair, comparable and non-discriminatory manner, with which all market participants comply; and

WHEREAS, the members of the WECC, including the Transmission Operator, have determined that a contractual Reliability Management System provides a reasonable, currently available means of maintaining such reliability.

NOW, THEREFORE, in consideration of the mutual agreements contained herein, and other good and valuable consideration, the receipt and sufficiency of which is hereby acknowledged, the Transmission Operator and the Generator agree as follows:

1. PURPOSE OF AGREEMENT

The purpose of this Agreement is to maintain the reliable operation of the Western Interconnection through the Generator's commitment to comply with certain reliability standards.

2. DEFINITIONS

In addition to terms defined in the beginning of this Agreement and in the Recitals hereto, for purposes of this Agreement the following terms shall have the meanings set forth beside them below.

Control Area means an electric system or systems, bounded by interconnection metering and telemetry, capable of controlling generation to maintain its interchange schedule with other Control Areas and contributing to frequency regulation of the Western Interconnection.

FERC means the Federal Energy Regulatory Commission or a successor agency.

Member means any party to the WECC Agreement.

Party means either the Generator or the Transmission Operator and **Parties** means both of the Generator and the Transmission Operator.

Reliability Management System or RMS means the contractual reliability management program implemented through the WECC Reliability Criteria Agreement, the WECC RMS Agreement, this Agreement, and any similar contractual arrangement.

Western Interconnection means the area comprising those states and provinces, or portions thereof, in Western Canada, Northern Mexico and the Western United States in which Members of the WECC operate synchronously connected transmission systems.

Working Day means Monday through Friday except for recognized legal holidays in the state in which any notice is received pursuant to Section 8.

WECC means the Western Electricity Coordinating Council or a successor entity.

WECC Agreement means the Western Electricity Coordinating Council Agreement dated March 20, 1967, as such may be amended from time to time.

WECC Reliability Criteria Agreement means the Western Electricity Coordinating Council Reliability Criteria Agreement dated _____, _____ among the WECC and certain of its member transmission operators, as such may be amended from time to time.

WECC RMS Agreement means an agreement between the WECC and the Transmission Operator requiring the Transmission Operator to comply with the reliability criteria contained in the WECC Reliability Criteria Agreement.

WECC Staff means those employees of the WECC, including personnel hired by the WECC on a contract basis, designated as responsible for the administration of the RMS.

3. TERM AND TERMINATION

3.1 Term. This Agreement shall become effective [thirty (30) days after the date of issuance of a final FERC order accepting this Agreement for filing without requiring any changes to this Agreement unacceptable to either Party. Required changes to this Agreement shall be deemed unacceptable to a Party only if that Party provides notice to the other Party within fifteen (15) days of issuance of the applicable FERC order that such order is unacceptable]. [Note: if the interconnection agreement is not FERC jurisdictional, replace bracketed language with: [on the later of: (a) the date of execution; or (b) the effective date of the WECC RMS Agreement.]

3.2 Notice of Termination of WECC RMS Agreement. The Transmission Operator shall give the Generator notice of any notice of termination of the WECC RMS Agreement by the WECC or by the Transmission Operator within fifteen (15) days of receipt by the WECC or the Transmission Operator of such notice of termination.

3.3 Termination by the Generator. The Generator may terminate this Agreement as follows:

(a) following the termination of the WECC RMS Agreement for any reason by the WECC or by the Transmission Operator, provided such notice is provided within forty-five (45) days of the termination of the WECC RMS Agreement;

(b) following the effective date of an amendment to the requirements of the WECC Reliability Criteria Agreement that adversely affects the Generator, provided notice of such termination is given within forty-five (45) days of the date of issuance of a FERC order accepting such amendment for filing, provided further that the forty-five (45) day period within which notice of termination is required may be extended by the Generator for an additional forty-five (45) days if the Generator gives written notice to the Transmission Operator of such requested extension within the initial forty-five (45) day period; or

(c) on one year's written notice to the Transmission Operator and the WECC, following any change in the WECC Reliability Criteria Agreement that materially affects Generator's obligations.

3.4 Termination by the Transmission Operator. The Transmission Operator may terminate this Agreement on thirty (30) days' written notice following the termination of the WECC RMS Agreement for any reason by the WECC or by the Transmission Operator, provided such notice is provided within thirty (30) days of the termination of the WECC RMS Agreement.

3.5 Mutual Agreement. This Agreement may be terminated at any time by the mutual agreement of the Transmission Operator and the Generator.

4. COMPLIANCE WITH AND AMENDMENT OF WECC RELIABILITY CRITERIA

4.1 Compliance with Reliability Criteria. The Generator agrees to comply with the requirements of the WECC Reliability Criteria Agreement, including the applicable WECC reliability criteria contained in Section IV of Annex A thereof, and, in the event of failure to comply, agrees to be subject to the sanctions applicable to such failure. Each and all of the provisions of the WECC Reliability Criteria Agreement are hereby incorporated by reference into this Agreement as though set forth fully herein, and the Generator shall for all purposes be considered a Participant, and shall be entitled to all of the rights and privileges and be subject to all of the obligations of a Participant, under and in connection with the WECC Reliability Criteria Agreement, including but not limited to the rights, privileges and obligations set forth in Sections 5, 6 and 10 of the WECC Reliability Criteria Agreement.

4.2 Modifications to WECC Reliability Criteria Agreement. The Transmission Operator shall notify the Generator within fifteen (15) days of the receipt of notice from the WECC of the initiation of any WECC process to modify the WECC Reliability Criteria Agreement. The WECC RMS Agreement specifies that such process shall comply with the procedures, rules, and regulations then applicable to the WECC for modifications to reliability criteria.

4.3 Notice of Modifications to WECC Reliability Criteria Agreement. If, following the process specified in Section 4.2, any modification to the WECC Reliability Criteria Agreement is to take effect, the Transmission Operator shall provide notice to the Generator at least forty-five (45) days before such modification is scheduled to take effect.

4.4 Effective Date. Any modification to the WECC Reliability Criteria Agreement shall take effect on the date specified by FERC in an order accepting such modification for filing.

4.5 Transfer of Control or Sale of Generation Facilities. In any sale or transfer of control of any generation facilities subject to this Agreement, the Generator shall as a condition of such sale or transfer require the acquiring party or transferee with respect to the transferred facilities either to assume the obligations of the Generator with respect to this Agreement or to enter into an agreement with the Control Area Operator in substantially the form of this Agreement.

5. SANCTIONS

5.1 Payment of Monetary Sanctions. The Generator shall be responsible for payment directly to the WECC of any monetary sanction assessed against the Generator pursuant to this Agreement and the WECC Reliability Criteria Agreement. Any such payment shall be made pursuant to the procedures specified in the WECC Reliability Criteria Agreement.

5.2 Publication. The Generator consents to the release by the WECC of information related to the Generator's compliance with this Agreement only in accordance with the WECC Reliability Criteria Agreement.

5.3 Reserved Rights. Nothing in the RMS or the WECC Reliability Criteria Agreement shall affect the right of the Transmission Operator, subject to any necessary regulatory approval, to take such other measures to maintain reliability, including disconnection, which the Transmission Operator may otherwise be entitled to take. Either Party shall have the right to make a unilateral filing with FERC to modify this Agreement with respect to any provision hereof under section 205, section 206, or any other applicable provision of the Federal Power Act and FERC's rules and regulations thereunder; provided that each Party shall have the right to protest any such filing by the other Party and to participate fully in any proceeding before FERC in which such modifications may be considered.

6. THIRD PARTIES

Except for the rights and obligations between the WECC and Generator specified in Sections 4 and 5, this Agreement creates contractual rights and obligations solely between the Parties. Nothing in this Agreement shall create, as between the Parties or with respect to the WECC: (1) any obligation or liability whatsoever (other than as expressly provided in this Agreement), or (2) any duty or standard of care whatsoever. In addition, nothing in this Agreement shall create any duty, liability, or standard of care whatsoever as to any other party. Except for the rights, as a third-party beneficiary with respect to Sections 4 and 5, of the WECC against Generator, no third party shall have any rights whatsoever with respect to enforcement of any provision of this Agreement. Transmission Operator and Generator expressly intend that the WECC is a third-party beneficiary to this Agreement, and the WECC shall have the right to seek to enforce against Generator any provisions of Sections 4 and 5, provided that specific performance shall be the sole remedy available to the WECC pursuant to this Agreement, and Generator shall not be liable to the WECC pursuant to this Agreement for damages of any kind whatsoever (other than the payment of sanctions to the WECC, if so construed), whether direct, compensatory, special, indirect, consequential, or punitive.

7. REGULATORY APPROVALS

This Agreement shall be filed with FERC by the Transmission Operator under Section 205 of the Federal Power Act. In such filing, the Transmission Operator shall request that FERC accept this Agreement for filing without modification to become effective on the day after the date of a FERC order accepting this Agreement for filing.

8. NOTICES

Any notice, demand or request required or authorized by this Agreement to be given in writing to a Party shall be delivered by hand, courier or overnight delivery service, mailed by certified mail (return receipt requested) postage prepaid, faxed, or delivered by mutually agreed electronic means to such Party at the following address:

_____:

Fax: _____

_____ : _____

Fax: _____

The designation of such person and/or address may be changed at any time by either Party upon receipt by the other of written notice. Such a notice served by mail shall be effective upon receipt. Notice transmitted by facsimile shall be effective upon receipt if received prior to 5:00 p.m. on a Working Day, and if not received prior to 5:00 p.m. on a Working Day, receipt shall be effective on the next Working Day.

9. APPLICABILITY

This Agreement (including all appendices hereto and, by reference, the WECC Reliability Criteria Agreement) constitutes the entire understanding between the Parties hereto with respect to the subject matter hereof, supersedes any and all previous understandings between the Parties with respect to the subject matter hereof, and binds and inures to the benefit of the Parties and their successors.

10. AMENDMENT

No amendment of all or any part of this Agreement shall be valid unless it is reduced to writing and signed by both Parties hereto. The terms and conditions herein specified shall remain in effect throughout the term and shall not be subject to change through application to the FERC or other governmental body or authority, absent the agreement of the Parties.

11. INTERPRETATION

Interpretation and performance of this Agreement shall be in accordance with, and shall be controlled by, the laws of the State of _____ but without giving effect to the provisions thereof relating to conflicts of law. Article and section headings are for convenience only and shall not affect the interpretation of this Agreement. References to articles, sections and appendices are, unless the context otherwise requires, references to articles, sections and appendices of this Agreement.

12. PROHIBITION ON ASSIGNMENT

This Agreement may not be assigned by either Party without the consent of the other Party, which consent shall not be unreasonably withheld; provided that the Generator may without the consent of the WECC or Transmission Operator assign this Agreement (a) as collateral security to aid in providing financing or refinancing for the construction, ownership or operation of the Generator's power generating facility, or (b) to any acquiring party or transferee referenced in Section 4.5 of this Agreement. If requested by Generator, Transmission Operator will enter into a consent on commercially reasonable terms to any assignment of this Agreement by Generator under this Section 12.

13. SEVERABILITY

If one or more provisions herein shall be invalid, illegal or unenforceable in any respect, it shall be given effect to the extent permitted by applicable law, and such invalidity, illegality or unenforceability shall not affect the validity of the other provisions of this Agreement.

14. COUNTERPARTS

This Agreement may be executed in counterparts and each shall have the same force and effect as an original.

IN WITNESS WHEREOF, the Transmission Operator and the Generator have each caused this Reliability Management System Agreement to be executed by their respective duly authorized officers as of the date first above written.

By: _____
Name:
Title:

By: _____
Name:
Title:

ATTACHMENT C

Redline comparison of:

(1) the APS *pro forma* LGIA in Appendix 6 to Attachment O of the APS FERC Electric Tariff, Fourteenth Revised Volume No. 2

to

(2) the Agreement.

Attachment C uses the APS LGIA as the “original” document and the Agreement as the “new” document.

For ease of reference, the headers and footers were removed from the APS LGIA prior to the creation of the redline comparison; therefore, the deletion of the headers and footers is not reflected in the redline comparison. To the extent necessary, the Filing Parties request waiver of the requirements of sections 35.10(b) and (c), 18 C.F.R. §§ 35.10(b) and 35.10(c) with regard to the headers and footers.

**Appendix 6 to the Standard Large
Generator Interconnection Procedures**

~~STANDARD~~ LARGE GENERATOR

INTERCONNECTION AGREEMENT ~~(LGIA)~~

BY AND BETWEEN

**AGUA CALIENTE SOLAR, LLC, AND NORTH GILA RIVER DEVELOPMENT, LLC
AS INTERCONNECTION CUSTOMER**

AND

**ARIZONA PUBLIC SERVICE COMPANY,
IMPERIAL IRRIGATION DISTRICT,
SAN DIEGO GAS & ELECTRIC COMPANY, AND
CALIFORNIA INDEPENDENT SYSTEM OPERATOR CORPORATION**

TABLE OF CONTENTS

	Page
RECITALS	314
<u>RECITALS</u>	<u>1</u>
ARTICLE 1. DEFINITIONS	315
<u>ARTICLE 1 DEFINITIONS</u>	<u>3</u>
ARTICLE 2. EFFECTIVE DATE, TERM, AND TERMINATION	323
<u>ARTICLE 2 EFFECTIVE DATE, TERM, AND TERMINATION</u>	<u>11</u>
2.1 EFFECTIVE DATE	323 <u>11</u>
2.2 TERM OF AGREEMENT	323 <u>12</u>
2.3 TERMINATION PROCEDURES	323 <u>12</u>
2.3.1 WRITTEN NOTICE	323 <u>12</u>
2.3.2 DEFAULT	323 <u>12</u>
2.4 TERMINATION COSTS	324 <u>12</u>
2.5 DISCONNECTION	324 <u>14</u>
2.6 SURVIVAL	325 <u>14</u>
ARTICLE 3. REGULATORY FILINGS	325
<u>ARTICLE 3. REGULATORY FILINGS</u>	<u>14</u>
3.1 FILING	325 <u>15</u>
ARTICLE 4. SCOPE OF SERVICE	325
<u>ARTICLE 4. SCOPE OF SERVICE</u>	<u>15</u>
4.1 INTERCONNECTION PRODUCT OPTIONS	325 <u>15</u>
4.1.1 <u>CAISO INTERCONNECTION SERVICE</u>	<u>15</u>
4.1.1.1 The Product	325
4.1.1.2 Transmission Delivery Service Implications	325
<u>4.1.2 ENERGY RESOURCE INTERCONNECTION SERVICE</u>	325 <u>15</u>
4.1.2 Network Resource Interconnection Service	326
4.1.2.1 THE PRODUCT	326 <u>15</u>
4.1.2.2 TRANSMISSION DELIVERY SERVICE IMPLICATIONS	326 <u>15</u>
<u>4.1.3 NETWORK RESOURCE INTERCONNECTION SERVICE</u>	<u>16</u>
<u>4.1.3.1 THE PRODUCT</u>	<u>16</u>

	4.1.3.2 TRANSMISSION DELIVERY SERVICE IMPLICATIONS.....	16
4.2	PROVISION OF SERVICE	328 16
4.3	PERFORMANCE STANDARDS	328 16
4.4	NO TRANSMISSION DELIVERY SERVICE	328 16
4.5	INTERCONNECTION CUSTOMER PROVIDED SERVICES	328 16

~~ARTICLE 5.— INTERCONNECTION FACILITIES ENGINEERING, PROCUREMENT, & CONSTRUCTION.....~~ [328](#)

ARTICLE 5. INTERCONNECTION FACILITIES ENGINEERING, PROCUREMENT, AND CONSTRUCTION [16](#)

5.1	OPTIONS.....	328 17
5.1.1	STANDARD OPTION	328 17
5.1.2	ALTERNATE OPTION	329 17
5.1.3	OPTION TO BUILD	329 17
5.1.4	NEGOTIATED OPTION.....	329 17
5.2	GENERAL CONDITIONS APPLICABLE TO OPTION TO BUILD.....	330 17
5.3	LIQUIDATED DAMAGES.....	331 17
5.4	POWER SYSTEM STABILIZERS	332 17
5.5	EQUIPMENT PROCUREMENT.....	332 18
5.6	CONSTRUCTION COMMENCEMENT	333 18
5.7	WORK PROGRESS.....	333 18
5.8	INFORMATION EXCHANGE	333 19
5.9	LIMITED OPERATION.....	333 19
5.10	INTERCONNECTION CUSTOMER'S INTERCONNECTION FACILITIES (' <u>ICIF</u> ')... 334 19	
5.10.1	INTERCONNECTION CUSTOMER'S INTERCONNECTION FACILITY SPECIFICATIONS	334 19
5.10.2	<u>REVIEW BY</u> TRANSMISSION Provider's Review <u>OWNERS AND CAISO</u> ... 334 19	
5.10.3	ICIF CONSTRUCTION	334 20
5.11	TRANSMISSION PROVIDER'S <u>OWNERS'</u> INTERCONNECTION FACILITIES CONSTRUCTION	334 20
5.12	ACCESS RIGHTS	335 20
5.13	LANDS OF OTHER PROPERTY OWNERS	335 21
5.14	PERMITS.....	335 21

5.15	EARLY CONSTRUCTION OF BASE CASE FACILITIES	335 <u>21</u>
5.16	SUSPENSION	336 <u>21</u>
5.17	TAXES	336 <u>22</u>
5.17.1	INTERCONNECTION CUSTOMER PAYMENTS NOT TAXABLE	336 <u>22</u>
5.17.2	REPRESENTATIONS AND COVENANTS	336 <u>22</u>
5.17.3	INDEMNIFICATION FOR THE COST CONSEQUENCES OF CURRENT TAX LIABILITY IMPOSED UPON THE TRANSMISSION Provider <u>OWNER</u>	337 <u>23</u>
5.17.4	TAX GROSS-UP AMOUNT	338 <u>23</u>
5.17.5	PRIVATE LETTER RULING OR CHANGE OR CLARIFICATION OF LAW	338 <u>24</u>
5.17.6	SUBSEQUENT TAXABLE EVENTS	339 <u>24</u>
5.17.7	CONTESTS	339 <u>24</u>
5.17.8	REFUND	340 <u>25</u>
5.17.9	TAXES OTHER THAN INCOME TAXES	341 <u>26</u>
	5.17.10 — Transmission Owners Who Are Not Transmission Providers	341
5.18	TAX STATUS	341 <u>27</u>
5.19	MODIFICATION	341 <u>27</u>
5.19.1	GENERAL	341 <u>27</u>
5.19.2	STANDARDS	342 <u>28</u>
5.19.3	MODIFICATION COSTS	342 <u>28</u>
ARTICLE 6. TESTING AND INSPECTION		342
<u>ARTICLE 6. TESTING AND INSPECTION</u>		<u>28</u>
6.1	PRE-COMMERCIAL OPERATION DATE TESTING AND MODIFICATIONS	342 <u>28</u>
6.2	POST-COMMERCIAL OPERATION DATE TESTING AND MODIFICATIONS	343 <u>29</u>
6.3	RIGHT TO OBSERVE TESTING	343 <u>29</u>
6.4	RIGHT TO INSPECT	343 <u>29</u>
ARTICLE 7. METERING		343
<u>ARTICLE 7. METERING</u>		<u>29</u>
7.1	GENERAL	343 <u>29</u>
7.2	CHECK METERS	343 <u>30</u>
7.3	STANDARDS	344 <u>30</u>
7.4	TESTING OF METERING EQUIPMENT	344 <u>30</u>

7.5	METERING DATA	344 <u>30</u>
7.6	<u>METERING REQUIREMENTS OF CAISO</u>	<u>30</u>
ARTICLE 8. COMMUNICATIONS		345
<u>ARTICLE 8. COMMUNICATIONS</u>		<u>31</u>
8.1	INTERCONNECTION CUSTOMER OBLIGATIONS	345 <u>31</u>
8.2	REMOTE TERMINAL UNIT	345 <u>31</u>
8.3	NO ANNEXATION	345 <u>32</u>
8.4	<u>COMMUNICATION REQUIREMENTS OF CAISO</u>	<u>32</u>
ARTICLE 9. OPERATIONS		346
<u>ARTICLE 9. OPERATIONS</u>		<u>32</u>
9.1	GENERAL	346 <u>32</u>
9.2	CONTROL <u>BALANCING AUTHORITY</u> AREA NOTIFICATION	346 <u>32</u>
9.3	TRANSMISSION PROVIDER <u>OWNER AND CAISO</u> OBLIGATIONS	346 <u>32</u>
9.4	INTERCONNECTION CUSTOMER OBLIGATIONS	346 <u>32</u>
9.5	START-UP AND SYNCHRONIZATION	346 <u>33</u>
9.6	REACTIVE POWER	347 <u>33</u>
9.6.1	POWER FACTOR DESIGN CRITERIA	347 <u>33</u>
9.6.2	VOLTAGE SCHEDULES	347 <u>33</u>
	9.6.2.1 GOVERNORS AND REGULATORS	347 <u>34</u>
9.6.3	PAYMENT FOR REACTIVE POWER	348 <u>34</u>
9.7	OUTAGES AND INTERRUPTIONS	348 <u>34</u>
9.7.1	OUTAGES	348 <u>34</u>
	9.7.1.1 OUTAGE AUTHORITY AND COORDINATION	348 <u>34</u>
	9.7.1.2 OUTAGE SCHEDULES	348 <u>35</u>
	9.7.1.3 OUTAGE RESTORATION	349 <u>35</u>
9.7.2	INTERRUPTION OF SERVICE	349 <u>36</u>
9.7.3	UNDER-FREQUENCY AND OVER FREQUENCY CONDITIONS	350 <u>37</u>
9.7.4	SYSTEM PROTECTION AND OTHER CONTROL REQUIREMENTS	350 <u>37</u>
	9.7.4.1 SYSTEM PROTECTION FACILITIES	350 <u>37</u>
9.7.5	REQUIREMENTS FOR PROTECTION	351 <u>38</u>
9.7.6	POWER QUALITY	351 <u>38</u>

9.8	SWITCHING AND TAGGING RULES.....	351 <u>38</u>
9.9	USE OF INTERCONNECTION FACILITIES BY THIRD PARTIES.....	351 <u>38</u>
9.9.1	PURPOSE OF INTERCONNECTION FACILITIES	352 <u>39</u>
9.9.2	THIRD PARTY USERS	352 <u>39</u>
9.10	DISTURBANCE ANALYSIS DATA EXCHANGE.....	352 <u>39</u>
ARTICLE 10. MAINTENANCE		352
<u>ARTICLE 10. MAINTENANCE.....</u>		<u>39</u>
10.1	TRANSMISSION PROVIDER <u>OWNER</u> OBLIGATIONS.....	352 <u>39</u>
10.2	INTERCONNECTION CUSTOMER OBLIGATIONS	352 <u>39</u>
10.3	COORDINATION.....	352 <u>39</u>
10.4	SECONDARY SYSTEMS	353 <u>40</u>
10.5	OPERATING AND MAINTENANCE EXPENSES.....	353 <u>40</u>
ARTICLE 11. PERFORMANCE OBLIGATION.....		353
<u>ARTICLE 11. PERFORMANCE OBLIGATION.....</u>		<u>40</u>
11.1	INTERCONNECTION CUSTOMER INTERCONNECTION FACILITIES.....	353 <u>40</u>
11.2	TRANSMISSION PROVIDER'S <u>OWNERS'</u> INTERCONNECTION FACILITIES	353 <u>40</u>
11.3	NETWORK UPGRADES AND DISTRIBUTION UPGRADES.....	353 <u>40</u>
11.4	TRANSMISSION CREDITS	353 <u>40</u>
11.4.1	REPAYMENT OF AMOUNTS ADVANCED <u>TO APS</u> FOR NETWORK UPGRADES <u>TO APS'S SHARE OF THE JPP</u>	353 <u>40</u>
11.4.2	<u>REPAYMENT OF AMOUNTS ADVANCED TO SDG&E FOR NETWORK UPGRADES TO ITS SHARE OF THE JPP AND TO ITS NON-JPP FACILITIES</u>	<u>41</u>
11.4.3	<u>REPAYMENT OF AMOUNTS ADVANCED TO IID FOR NETWORK UPGRADES TO IID'S SHARE OF THE JPP.....</u>	<u>42</u>
11.4.4	<u>SPECIAL PROVISIONS FOR AFFECTED SYSTEMS</u>	<u>43</u>
11.5	PROVISION OF SECURITY.....	355 <u>44</u>
11.6	INTERCONNECTION CUSTOMER COMPENSATION.....	355 <u>46</u>
11.6.1	INTERCONNECTION CUSTOMER COMPENSATION FOR ACTIONS DURING EMERGENCY CONDITION.....	356 <u>46</u>
ARTICLE 12. INVOICE		356
<u>ARTICLE 12. INVOICE</u>		<u>46</u>

12.1	GENERAL <u>PROVISIONS</u>	356 <u>46</u>
12.2	FINAL INVOICE.....	356 <u>47</u>
12.3	PAYMENT.....	356 <u>47</u>
12.4	DISPUTES	356 <u>47</u>
ARTICLE 13. EMERGENCIES.....		357
<u>ARTICLE 13. EMERGENCIES.....</u>		<u>48</u>
13.1	DEFINITION	357 <u>48</u>
13.2	OBLIGATIONS.....	357 <u>48</u>
13.3	NOTICE	357 <u>48</u>
13.4	IMMEDIATE ACTION.....	357 <u>48</u>
13.5	TRANSMISSION PROVIDER <u>OWNER AND CAISO</u> AUTHORITY	357 <u>49</u>
	13.5.1 GENERAL	358 <u>49</u>
	13.5.2 REDUCTION AND DISCONNECTION	358 <u>49</u>
13.6	INTERCONNECTION CUSTOMER AUTHORITY	358 <u>50</u>
13.7	LIMITED LIABILITY	359 <u>50</u>
ARTICLE 14. REGULATORY REQUIREMENTS AND GOVERNING LAW		359
<u>ARTICLE 14. REGULATORY REQUIREMENTS AND GOVERNING LAW</u>		<u>50</u>
14.1	REGULATORY REQUIREMENTS.....	359 <u>50</u>
14.2	GOVERNING LAW.....	359 <u>50</u>
ARTICLE 15. NOTICES.....		360
<u>ARTICLE 15. NOTICES.....</u>		<u>50</u>
15.1	GENERAL	360 <u>50</u>
15.2	BILLINGS AND PAYMENTS.....	360 <u>51</u>
15.3	ALTERNATIVE FORMS OF NOTICE	360 <u>51</u>
15.4	OPERATIONS AND MAINTENANCE NOTICE.....	360 <u>51</u>
ARTICLE 16. FORCE MAJEURE		360
<u>ARTICLE 16. FORCE MAJEURE.....</u>		<u>51</u>
ARTICLE 17. DEFAULT.....		361
<u>ARTICLE 17. DEFAULT</u>		<u>51</u>
17.1	DEFAULT	361 <u>51</u>

17.1.1	GENERAL	361 <u>51</u>
17.1.2	RIGHT TO TERMINATE.....	361 <u>52</u>
ARTICLE 18. INDEMNITY, CONSEQUENTIAL DAMAGES AND INSURANCE		361
<u>ARTICLE 18. INDEMNITY, CONSEQUENTIAL DAMAGES AND INSURANCE.....</u>		<u>52</u>
18.1	INDEMNITY	361 <u>52</u>
18.1.1	INDEMNIFIED <i>Person</i> <u>PARTY</u>	361 <u>52</u>
18.1.2	INDEMNIFYING PARTY	362 <u>52</u>
18.1.3	INDEMNITY PROCEDURES.....	362 <u>52</u>
18.2	CONSEQUENTIAL DAMAGES.....	362 <u>53</u>
18.3	INSURANCE	363 <u>53</u>
ARTICLE 19. ASSIGNMENT.....		364
<u>ARTICLE 19. ASSIGNMENT</u>		<u>55</u>
ARTICLE 20. SEVERABILITY.....		365
<u>ARTICLE 20. SEVERABILITY</u>		<u>55</u>
ARTICLE 21. COMPARABILITY		366
<u>ARTICLE 21. COMPARABILITY</u>		<u>56</u>
ARTICLE 22. CONFIDENTIALITY.....		366
<u>ARTICLE 22. CONFIDENTIALITY</u>		<u>56</u>
22.1	CONFIDENTIALITY	366 <u>56</u>
22.1.1	TERM	366 <u>56</u>
22.1.2	SCOPE	366 <u>56</u>
22.1.3	RELEASE OF CONFIDENTIAL INFORMATION	367 <u>57</u>
22.1.4	RIGHTS.....	367 <u>57</u>
22.1.5	NO WARRANTIES	367 <u>57</u>
22.1.6	STANDARD OF CARE	367 <u>57</u>
22.1.7	Order of DISCLOSURE <u>REQUIRED BY LAW OR ORDER</u>	367 <u>57</u>
22.1.8	TERMINATION OF AGREEMENT	367 <u>58</u>
22.1.9	REMEDIES	368 <u>58</u>
22.1.10	DISCLOSURE TO FERC, ITS STAFF, OR A STATE.....	368 <u>58</u>
ARTICLE 23. ENVIRONMENTAL RELEASES.....		369

<u>ARTICLE 23. ENVIRONMENTAL RELEASES.....</u>	<u>59</u>
ARTICLE 24. INFORMATION REQUIREMENTS	369
<u>ARTICLE 24. INFORMATION REQUIREMENTS</u>	<u>59</u>
24.1 INFORMATION ACQUISITION	369 <u>59</u>
24.2 INFORMATION SUBMISSION BY <u>APS, ON BEHALF OF</u> TRANSMISSION PROVIDER OWNERS	369 <u>59</u>
24.3 UPDATED INFORMATION SUBMISSION BY INTERCONNECTION CUSTOMER.....	369 <u>59</u>
24.4 INFORMATION SUPPLEMENTATION.....	370 <u>60</u>
ARTICLE 25. INFORMATION ACCESS AND AUDIT RIGHTS	371
<u>ARTICLE 25. INFORMATION ACCESS AND AUDIT RIGHTS</u>	<u>61</u>
25.1 INFORMATION ACCESS.....	371 <u>61</u>
25.2 REPORTING OF NON-FORCE MAJEURE EVENTS.....	371 <u>61</u>
25.3 AUDIT RIGHTS	371 <u>61</u>
25.4 AUDIT RIGHTS PERIODS	371 <u>61</u>
25.4.1 AUDIT RIGHTS PERIOD FOR CONSTRUCTION-RELATED ACCOUNTS AND RECORDS.....	371 <u>62</u>
25.4.2 AUDIT RIGHTS PERIOD FOR ALL OTHER ACCOUNTS AND RECORDS	372 <u>62</u>
25.5 AUDIT RESULTS	372 <u>62</u>
ARTICLE 26. SUBCONTRACTORS	372
<u>ARTICLE 26. SUBCONTRACTORS.....</u>	<u>62</u>
26.1 GENERAL	372 <u>62</u>
26.2 RESPONSIBILITY OF PRINCIPAL	372 <u>62</u>
26.3 NO LIMITATION BY INSURANCE	372 <u>62</u>
ARTICLE 27. DISPUTES	372
<u>ARTICLE 27. DISPUTES</u>	<u>62</u>
27.1 SUBMISSION.....	372 <u>63</u>
27.2 EXTERNAL ARBITRATION PROCEDURES.....	373 <u>63</u>
27.3 ARBITRATION DECISIONS.....	373 <u>63</u>
27.4 COSTS	373 <u>63</u>
ARTICLE 28. REPRESENTATIONS, WARRANTIES, AND COVENANTS	373

<u>ARTICLE 28. REPRESENTATIONS, WARRANTIES, AND COVENANTS</u>	<u>63</u>
28.1 GENERAL	373 <u>64</u>
28.1.1 GOOD STANDING	373 <u>64</u>
28.1.2 AUTHORITY	374 <u>64</u>
28.1.3 NO CONFLICT.....	374 <u>64</u>
28.1.4 CONSENT AND APPROVAL.....	374 <u>64</u>
ARTICLE 29. JOINT OPERATING COMMITTEE.....	375
<u>ARTICLE 29. JOINT OPERATING COMMITTEE.....</u>	<u>64</u>
ARTICLE 30. MISCELLANEOUS.....	375
<u>ARTICLE 30. MISCELLANEOUS</u>	<u>65</u>
30.1 BINDING EFFECT	375 <u>65</u>
30.2 CONFLICTS.....	376 <u>65</u>
30.3 RULES OF INTERPRETATION	376 <u>65</u>
30.4 ENTIRE AGREEMENT	376 <u>66</u>
30.5 NO THIRD PARTY BENEFICIARIES	376 <u>66</u>
30.6 WAIVER	376 <u>66</u>
30.7 HEADINGS.....	377 <u>66</u>
30.8 MULTIPLE COUNTERPARTS	377 <u>66</u>
30.9 AMENDMENT	377 <u>66</u>
30.10 MODIFICATION BY THE PARTIES	377 <u>66</u>
30.11 RESERVATION OF RIGHTS	377 <u>67</u>
30.12 NO PARTNERSHIP.....	377 <u>67</u>
<u>30.13 JOINT AND SEVERAL OBLIGATIONS.....</u>	<u>67</u>

APPENDICES

~~Appendix A — Interconnection Facilities, Network Upgrades, and Distribution Upgrades~~

Appendix A-1 — Interconnection Facilities, JPP Network Upgrades, and Distribution Upgrades for Phase A of the Interconnection Project

Appendix A-2 — Interconnection Facilities, JPP Network Upgrades, and Distribution Upgrades for Phase B of the Interconnection Project

Appendix A-3 — SDG&E Network Upgrades for Phase B of the Interconnection Project

~~Appendix B — Milestones~~

Appendix B-1 — Milestones for Interconnection Facilities and JPP Network Upgrades for Phase A of the Interconnection Project

Appendix B-2 — Milestones for Interconnection Facilities and JPP Network Upgrades for Phase B of the Interconnection Project

Appendix B-3 — Milestones for SDG&E Network Upgrades for Phase B of the Interconnection Project

Appendix C — Interconnection Details

Appendix D — Security Arrangements Details

Appendix E — Commercial Operation Date

Appendix F — Addresses for Delivery of Notices and Billings

Appendix G — Requirements of a Wind Generating Plant

Appendix H — Reliability Management System Agreement

~~STANDARD~~ LARGE GENERATOR INTERCONNECTION AGREEMENT

~~THIS STANDARD~~ LARGE GENERATOR INTERCONNECTION AGREEMENT ("Agreement") is made and entered into this ____ day of _____ 20__, by and between _____, a _____ Agua Caliente Solar, LLC, to which NextLight Renewable Power, LLC ("NextLight") has duly assigned its Interconnection Requests only as to Phase A of the Generating Facility, and North Gila River Development, LLC, to which NextLight has duly assigned its Interconnection Request submitted only to APS only as to Phase B of the Generating Facility, each of which is a corporation organized and existing under the laws of the State/~~Commonwealth of _____~~ (of Delaware, (collectively Agua Caliente Solar, LLC and North Gila River Development, LLC are the "Interconnection Customer" with a Large Generating Facility), and _____, a _____ Arizona Public Service Company ("APS"), a corporation organized and existing under the laws of the State/~~Commonwealth of _____~~ ("Transmission Provider and/or Transmission Owner") of Arizona, Imperial Irrigation District ("IID"), an irrigation district organized under the Water Code of the State of California, San Diego Gas & Electric Company ("SDG&E"), a corporation organized under the laws of the State of California, and California Independent System Operator Corporation ("CAISO"), a nonprofit public benefit corporation organized and existing under the laws of California. Interconnection Customer, APS, IID, SDG&E and ~~Transmission Provider~~CAISO each may be referred to as a "Party" or collectively as the "Parties."

Recitals

WHEREAS, ~~Transmission Provider operates~~ APS and SDG&E entered into the Arizona Transmission System; and Participation Agreement, dated June 24, 1981 ("Participation Agreement");

WHEREAS, APS, IID, and SDG&E entered into Amendment No. 1 to the Participation Agreement, dated January 22, 1985 ("Amendment No. 1"), pursuant to which SDG&E assigned and transferred an undivided interest in the Arizona Transmission System to IID;

WHEREAS, APS, IID, and SDG&E ("Joint Participants" or "Transmission Owners") own the Joint Participation Project ("JPP") as set forth in the Participation Agreement, amended by Amendment No. 1;

WHEREAS, APS acts as the Operating Agent of the JPP pursuant to the Participation Agreement, as amended;

WHEREAS, APS and the CAISO are parties to the Interconnected Control Area Operating Agreement, dated November 26, 1997;

WHEREAS, APS, IID, SDG&E, and the CAISO provide transmission service on their respective Transmission Systems;

WHEREAS, Interconnection Customer intends to own, lease and/or control and operate the Generating Facility identified as a Large Generating Facility in Appendix C to this Agreement; ~~and~~,

WHEREAS, NextLight, submitted an Interconnection ~~Customer and Transmission Provider~~ Request for such Large Generating Facility to APS on February 22, 2008, and also submitted an Interconnection Request for Phase A of the Large Generating Facility to CAISO on June 2, 2008;

WHEREAS, NextLight and APS, on behalf of the Joint Participants, entered into an Engineering & Procurement Agreement dated March 30, 2010, to begin design and procurement work for certain Interconnection Facilities to be constructed pursuant to this Agreement and NextLight duly assigned the Engineering & Procurement Agreement to Agua Caliente Solar, LLC;

WHEREAS, the Parties have agreed to enter into this Agreement for the purpose of interconnecting the Large Generating Facility with the ~~Transmission System~~; JPP; and

WHEREAS, all Parties that are public utilities subject to the jurisdiction of the Federal Energy Regulatory Commission (“FERC”) will file this Agreement simultaneously, as a service agreement under their respective Tariffs.

NOW, THEREFORE, in consideration of and subject to the mutual covenants contained herein, it is agreed:

When used in this ~~Standard Large Generator Interconnection~~ Agreement, terms with initial capitalization that are not defined in Article 1 shall have the meanings specified in the Article in which they are used or in the APS Open Access Transmission Tariff (or the CAISO Tariff), as applicable.

When an Article of this Agreement contains the phrase “THIS ARTICLE IS NOT APPLICABLE TO THIS AGREEMENT,” or “THIS SECTION IS NOT APPLICABLE TO THIS AGREEMENT,” or “THIS PARAGRAPH IS NOT APPLICABLE TO THIS AGREEMENT,” or when an Appendix to this Agreement contains the phrase “THIS APPENDIX IS NOT APPLICABLE TO THIS AGREEMENT,” the Article, Section, Paragraph or Appendix will have no force and effect with respect to this Agreement.

Article 1. Definitions

Adverse System Impact shall mean the negative effects due to technical or operational limits on conductors or equipment being exceeded that may compromise the safety and reliability of the electric system.

Affected System shall mean an electric system other than the ~~Transmission Provider~~ APS or SDG&E's Transmission System ~~Systems or IID's share of the JPP~~ that may be affected by the proposed interconnection.

Affected System Operator shall mean the entity that operates an Affected System.

Affected System Construction and Operation Agreement shall mean an agreement between the Interconnection Customer and IID to pay the costs of Network Upgrades, for either of the Project Phases, to IID's Transmission System, other than IID's share of the JPP, and to provide for repayment of amounts advanced to IID with transmission rate credits when transmission service is taken on IID's Transmission System.

Affected System Study shall mean an engineering study that evaluates the impacts of the proposed interconnection of either Project Phase on the safety and reliability of the Transmission System owned by IID, other than IID's share of the JPP, and provides a list of facilities that are required as a result of proposed interconnection, along with an estimate of cost responsibility and time to construct. This Affected System Study may be performed, at IID's option, either serially or in a cluster.

Affected System Study Agreement shall mean an agreement between the Interconnection Customer and IID whereby IID will perform and Interconnection Customer will pay the costs of an Affected System Study. The total costs will be pro rated to the extent IID performs the Affected System Study in a cluster for multiple generators seeking to interconnect to the CAISO controlled grid, with Interconnection Customer allocated a proportionate share of the total costs.

Affiliate shall mean, with respect to a corporation, partnership or other entity, each such other corporation, partnership or other entity that directly or indirectly, through one or more intermediaries, controls, is controlled by, or is under common control with, such corporation, partnership or other entity.

Ancillary Services shall mean those services that are necessary to support the transmission of capacity and energy from resources to loads while maintaining reliable operation of the Transmission ~~Provider's Transmission~~ System in accordance with Good Utility Practice.

Applicable Laws and Regulations shall mean all duly promulgated applicable federal, state and local laws, regulations, rules, ordinances, codes, decrees, judgments, directives, or judicial or administrative orders, permits and other duly authorized actions of any Governmental Authority.

Applicable Reliability Council shall mean the ~~reliability council applicable to the Transmission System to which the Generating Facility is directly interconnected~~ Western Electricity Coordinating Council or its successor.

Applicable Reliability Standards shall mean the requirements and guidelines of NERC, the Applicable Reliability Council, and the ~~Control Area of the Transmission System to which the Generating Facility is directly interconnected~~ applicable Balancing Authority.

Balancing Authority shall mean the responsible entity that integrates resource plans ahead of time, maintains load-interchange-generation balance within a Balancing Authority Area, and supports interconnection frequency in real time.

Balancing Authority Area shall mean the collection of generation, transmission, and loads within the metered boundaries of the Balancing Authority. The Balancing Authority maintains load resource balance within this area.

Base Case shall mean the base case power flow, short circuit, and stability data bases used for the Interconnection Studies by ~~the Transmission Provider~~ APS, the CAISO and its designees, or Interconnection Customer.

Breach shall mean the failure of a Party to perform or observe any material term or condition of ~~the Standard Large Generator Interconnection~~ this Agreement.

Breaching Party shall mean a Party that is in Breach of ~~the Standard Large Generator Interconnection~~ this Agreement.

Business Day shall mean Monday through Friday, excluding Federal Holidays and the day after Thanksgiving Day.

Calendar Day shall mean any day including Saturday, Sunday or a Federal Holiday.

CAISO Interconnection Service shall have the meaning set forth in Article 4.1.1.

Clustering shall mean the process whereby a group of Interconnection Requests is studied together, instead of serially, for the purpose of conducting the Interconnection System Impact Study.

Commercial Operation shall mean the status of a Project Block at a Generating Facility that has commenced generating electricity for sale, excluding electricity generated during Trial Operation.

Commercial Operation Date ~~of a unit~~ shall mean the date on which the ~~Generating Facility commences Commercial Operation as~~ Interconnection Customer declares completion of all Project Blocks within a Project Phase, as described in Appendix E to this Agreement and in accordance with the implementation plan agreed to by the Parties ~~pursuant to Appendix E to the Standard Large Generator Interconnection Agreement.~~ for multiple Project Blocks at the Generating Facility.

Confidential Information shall mean any confidential, proprietary or trade secret information of a plan, specification, pattern, procedure, design, device, list, concept, policy or compilation relating to the present or planned business of a Party, which is designated as confidential by the Party supplying the information, whether conveyed orally, electronically, in writing, through inspection, or otherwise, subject to Article 22.1.2.

~~Control Area shall mean an electrical system or systems bounded by interconnection metering and telemetry, capable of controlling generation to maintain its interchange schedule with other Control Areas and contributing to frequency regulation of the interconnection. A Control Area must be certified by the Applicable Reliability Council.~~

Default shall mean the failure of a Breaching Party to cure its Breach in accordance with Article 17 of ~~the Standard Large Generator Interconnection~~ this Agreement.

Dispute Resolution shall mean the procedure for resolution of a dispute between the Parties in which they will first attempt to resolve the dispute on an informal basis.

Distribution System shall mean ~~the Transmission Provider's~~ each of the respective facilities and equipment of APS, IID or SDG&E used to transmit electricity to ultimate usage points such as homes and industries directly from nearby generators or from interchanges with higher voltage transmission networks which transport bulk power over longer distances. The voltage levels at which distribution systems operate differ among areas.

Distribution Upgrades shall mean the additions, modifications, and upgrades to the ~~Transmission Provider's~~ Distribution System at or beyond the Point of Interconnection to facilitate interconnection of the Generating Facility and render the transmission service necessary to effect Interconnection Customer's wholesale sale of electricity in interstate commerce. Distribution Upgrades do not include Interconnection Facilities.

Effective Date shall mean the date on which ~~the Standard Large Generator Interconnection~~ this Agreement becomes effective upon execution by the Parties subject to acceptance by FERC, or if filed unexecuted pursuant to Section 205 of the Federal Power Act, upon the date specified by FERC, for those Parties which are FERC-jurisdictional public utilities; provided, however, that, as applied to IID, the Effective Date of this Agreement shall not commence until the Agreement is actually executed by IID, either voluntarily or pursuant to a lawful order issued by FERC in accordance with Sections 210 and 212 of the Federal Power Act.

Emergency Condition shall mean a condition or situation: (1) that in the judgment of the Party making the claim is imminently likely to endanger life or property; or (2) that, in the case of a Transmission ~~Provider~~ Owner or the CAISO, is imminently likely (as determined in a non-discriminatory manner) to cause a material adverse effect on the security of, or damage to ~~Transmission Provider's~~ sits Transmission System, ~~Transmission Provider's~~ sits Interconnection Facilities or the electric systems of others to which ~~the Transmission Provider's~~ sits Transmission System is directly connected; or (3) that, in the case of Interconnection Customer, is imminently likely (as determined in a non-discriminatory manner) to cause a material adverse effect on the security of, or damage to, the Generating Facility or Interconnection Customer's Interconnection Facilities. System restoration and black start shall be considered Emergency Conditions;

provided, that Interconnection Customer is not obligated by ~~the Standard Large Generator Interconnection~~ this Agreement to possess black start capability.

Energy Resource Interconnection Service shall mean an Interconnection Service that allows the Interconnection Customer to connect its Generating Facility to the ~~Transmission Provider's~~ APS Transmission System and IID's share of the JPP to be eligible to deliver the Generating Facility's electric output using the existing firm or nonfirm capacity of the ~~Transmission Provider's~~ APS Transmission System and IID's share of the JPP on an as available basis. Energy Resource Interconnection Service in and of itself does not convey transmission service.

Engineering & Procurement (E&P) Agreement shall mean an agreement ~~that authorizes~~ between NextLight and APS, on behalf of the Transmission ~~Provider~~ Owners pursuant to the Participation Agreement, to begin engineering and procurement of long lead-time items necessary for the establishment of the interconnection in order to advance the implementation of the Interconnection ~~Request~~ Requests for Phase A of the Interconnection Project, which has been duly assigned to Agua Caliente Solar, LLC.

Environmental Law shall mean Applicable Laws or Regulations relating to pollution or protection of the environment or natural resources.

Federal Power Act shall mean the Federal Power Act, as amended, 16 U.S.C. §§ 791a et seq.

FERC shall mean the Federal Energy Regulatory Commission ~~(Commission)~~ or its successor.

Force Majeure shall mean any act of God, labor disturbance, act of the public enemy, war, insurrection, riot, fire, storm or flood, earthquake, explosion, breakage or accident to machinery or equipment, any order, regulation or restriction imposed by governmental, military or lawfully established civilian authorities, or any other cause beyond a Party's control. A Force Majeure event does not include acts of negligence or intentional wrongdoing by the Party claiming Force Majeure.

Generating Facility shall mean Interconnection Customer's device for the production of electricity identified in the Interconnection Request(s), but shall not include the Interconnection Customer's Interconnection Facilities. The Generating Facility consists of Phase A of the Generating Facility and Phase B of the Generating Facility.

Generating Facility Capacity shall mean the net capacity of the Generating Facility and the aggregate net capacity of the Generating Facility where it includes multiple energy production devices.

Good Utility Practice shall mean any of the practices, methods and acts engaged in or approved by a significant portion of the electric utility industry during the relevant time period, or any of the practices, methods and acts which, in the exercise of reasonable judgment in light of the facts known at the time the decision was made, could have been expected to accomplish the desired result at a reasonable cost consistent with good business practices, reliability, safety and

expedition. Good Utility Practice is not intended to be ~~limited to any one of a number of~~ the optimum ~~practice, method~~ practices, methods, or ~~acts~~ to the exclusion of all others, but rather to be acceptable practices, methods, or acts generally accepted in the region.

Governmental Authority shall mean any federal, state, local or other governmental regulatory or administrative agency, court, commission, department, board, or other governmental subdivision, legislature, rulemaking board, tribunal, or other governmental authority having jurisdiction over the Parties, their respective facilities, or the respective services they provide, and exercising or entitled to exercise any administrative, executive, police, or taxing authority or power; provided, however, that such term does not include Interconnection Customer, Transmission ~~Provider~~ Owners, the CAISO, or any Affiliate thereof.

Hazardous Substances shall mean any chemicals, materials or substances defined as or included in the definition of "hazardous substances," "hazardous wastes," "hazardous materials," "hazardous constituents," "restricted hazardous materials," "extremely hazardous substances," "toxic substances," "radioactive substances," "contaminants," "pollutants," "toxic pollutants" or words of similar meaning and regulatory effect under any applicable Environmental Law, or any other chemical, material or substance, exposure to which is prohibited, limited or regulated by any applicable Environmental Law.

Initial Synchronization Date shall mean the date upon which the ~~Generating Facility~~ first Project Block of a Project Phase is initially synchronized and upon which Trial Operation begins.

In-Service Date shall mean the date upon which the Interconnection Customer reasonably expects it will be ready to begin use of the Transmission ~~Provider's~~ Owners' Interconnection Facilities to obtain back feed power.

Interconnection Customer shall mean ~~any entity, including the Transmission Provider, Transmission Owner or any of the Affiliates or subsidiaries of either, that proposes to interconnect its Generating Facility with the Transmission Provider's Transmission System~~ Agua Caliente Solar LLC, to which NextLight has duly assigned its Interconnection Requests for Phase A of the Generating Facility, and North Gila River Development, LLC, to which NextLight has duly assigned its Interconnection Request submitted only to APS for Phase B of the Generating Facility, and their successors and assigns.

Interconnection Customer's Interconnection Facilities shall mean all facilities and equipment, as identified in ~~Appendix A of the Standard Large Generator Interconnection~~ Appendices A-1 and A-2 of this Agreement, that are located between the Generating Facility and the Point of Change of Ownership, including any modification, addition, or upgrades to such facilities and equipment necessary to physically and electrically interconnect the Generating Facility to the ~~Transmission Provider's Transmission System~~ JPP. Interconnection Customer's Interconnection Facilities are sole use facilities.

Interconnection Facilities shall mean the Transmission ~~Provider's~~ Owners' Interconnection Facilities and the Interconnection Customer's Interconnection Facilities. Collectively, Interconnection Facilities include all facilities and equipment between the Generating Facility and the Point of Interconnection, including any modification, additions or

upgrades that are necessary to physically and electrically interconnect the Generating Facility to the ~~Transmission Provider's Transmission System~~JPP. Interconnection Facilities are sole use facilities and shall not include Distribution Upgrades, Stand Alone Network Upgrades or Network Upgrades.

Interconnection Facilities Study shall mean a study conducted by ~~the Transmission Provider~~APS or a third party consultant for the Interconnection Customer to determine a list of facilities (including Transmission ~~Provider's Owners'~~ Interconnection Facilities and Network Upgrades to the JPP as identified in the Interconnection System Impact Study), the cost of those facilities, and the time required to interconnect the Generating Facility with the ~~Transmission Provider's Transmission System~~The JPP; the scope of the study is defined in Section 8 of the ~~Standard~~APS Large Generator Interconnection Procedures.

~~—————Interconnection Facilities Study Agreement shall mean the form of agreement contained in Appendix 4 of the Standard Large Generator Interconnection Procedures for conducting the Interconnection Facilities Study.~~

Interconnection Feasibility Study shall mean a preliminary evaluation of the system impact and cost of interconnecting the Generating Facility to the ~~Transmission Provider's Transmission System~~JPP, the scope of which is described in Section 6 of the ~~Standard~~APS Large Generator Interconnection Procedures.

~~Interconnection Feasibility Study Agreement shall mean the form of agreement contained in Appendix 2 of the Standard~~**Financial Security** shall have the meaning assigned to it in Section 1.2 of the CAISO's Large Generator Interconnection Procedures ~~for conducting the Interconnection Feasibility Study.~~

Interconnection Request shall mean ~~an Interconnection Customer's~~a request, in the form of Appendix 1 to the ~~Standard~~ Large Generator Interconnection Procedures, in accordance with the ~~Tariff~~APS or CAISO Tariffs, to interconnect a new Generating Facility, or to increase the capacity of, or make a Material Modification to the operating characteristics of, an existing Generating Facility that is interconnected with the ~~Transmission Provider's Transmission System~~JPP. The Interconnection Customer made an Interconnection Request to APS for both Phase A of the Generating Facility and Phase B of the Generating Facility and an Interconnection Request to the CAISO only for Phase A of the Generating Facility. The Interconnection Customer did not make an Interconnection Request to IID.

Interconnection Service shall mean the service provided by the Transmission ~~Provider~~Owners and the CAISO associated with interconnecting the Interconnection Customer's Generating Facility to the ~~Transmission Provider's Transmission System~~JPP and enabling ~~it~~them to receive electric energy and capacity from the Generating Facility at the Point of Interconnection, pursuant to the terms of ~~the Standard Large Generator Interconnection Agreement and, if applicable, the Transmission Provider's Tariff~~this Agreement and the Tariffs of APS, IID, SDG&E, and the CAISO.

Interconnection Study shall mean any of the following studies: (1) the Interconnection Feasibility Study, the Interconnection System Impact Study, and/or the Interconnection Facilities Study described in the StandardAPS Large Generator Interconnection Procedures; or (2) the

[Phase I Interconnection Study or the Phase II Interconnection Study described in the CAISO Large Generator Interconnection Procedures.](#)

Interconnection System Impact Study shall mean an engineering study that evaluates the impact of the proposed interconnection on the safety and reliability of Transmission ~~Provider's~~[Owners'](#) Transmission ~~System~~[Systems](#) and, if applicable, an Affected System. The study shall identify and detail the system impacts that would result if the Generating Facility were interconnected without project modifications or system modifications, focusing on the Adverse System Impacts identified in the Interconnection Feasibility Study, or to study potential impacts, including but not limited to those identified in the Scoping Meeting as described in the ~~Standard~~[APS](#) Large Generator Interconnection Procedures.

Interconnection System Impact Study Agreement shall mean the form of agreement contained in ~~Appendix 3 of the Standard~~ Large Generator Interconnection Procedures [of APS](#) for conducting ~~the~~[an](#) Interconnection System Impact Study.

IRS shall mean the Internal Revenue Service.

Joint Operating Committee shall be a group made up of representatives from Interconnection ~~Customers~~[Customer](#) and [APS, on behalf of](#) the Transmission ~~Provider~~[Owners](#), to coordinate operating and technical considerations of Interconnection Service.

[Joint Participation Project \(JPP\) shall mean the transmission facilities jointly owned by APS, IID and SDG&E pursuant to the Arizona Transmission System Participation Agreement, as amended.](#)

Large Generating Facility shall mean a Generating Facility having a Generating Facility Capacity of more than 20 MW.

[Large Generator Interconnection Procedures \(LGIP\) shall mean the interconnection procedures applicable to an Interconnection Request pertaining to a Large Generating Facility that are included in the APS or the CAISO Tariff. With respect to the Interconnection Request made to the CAISO for Phase A of the Generating Facility, the applicable LGIP is the LGIP for Interconnection Requests in a Queue Cluster Window, which is found in CAISO Tariff Appendix Y.](#)

Loss shall mean any and all [damages, losses and claims, including claims and actions](#) relating to injury to or death of any person or damage to property, demand, suits, recoveries, costs and expenses, court costs, attorney fees, and all other obligations by or to third parties, ~~arising out of or resulting from the other Party's performance, or non-performance of its obligations under the Standard Large Generator Interconnection Agreement on behalf of the indemnifying Party, except in cases of gross negligence or intentional wrongdoing by the indemnifying Party.~~

Material Modification shall mean those modifications that have a material impact on the cost or timing of any Interconnection Request [or any other valid interconnection request](#) with a later queue priority date.

Metering Equipment shall mean all metering equipment installed or to be installed for measuring the output at the Generating Facility pursuant to ~~the Standard Large Generator Interconnection~~this Agreement at the metering points, including but not limited to instrument transformers, MWh-meters, data acquisition equipment, transducers, remote terminal unit, communications equipment, phone lines, and fiber optics.

NERC shall mean the North American Electric Reliability ~~Council~~Corporation or its successor organization.

Network Resource shall mean any designated generating resource owned, purchased, or leased by a Network Customer under the APS Network Integration Transmission Service Tariff or the IID Open Access Transmission Tariff. Network Resources do not include any resource, or any portion thereof, that is committed for sale to third parties or otherwise cannot be called upon to meet the Network Customer's Network Load on a non-interruptible basis.

Network Resource Interconnection Service shall mean an Interconnection Service that allows ~~the Interconnection Customer~~an interconnection customer to integrate its Large Generating Facility with the ~~Transmission Provider's~~APS Transmission System ~~(1) or IID's share of the JPP~~ in a manner comparable to that in which ~~the Transmission Provider~~APS or IID integrates its generating facilities to serve native load customers; ~~or (2) in an RTO or ISO with market based congestion management, in the same manner as Network Resources.~~ Network Resource Interconnection Service in and of itself does not convey transmission service.

Network Upgrades shall mean the additions, modifications, and upgrades to the Transmission ~~Provider~~Owners' and CAISO's Transmission ~~System~~Systems required at or beyond the point at which the Interconnection Facilities connect to the ~~Transmission Provider's Transmission System~~JPP to accommodate the interconnection of the Large Generating Facility to the Transmission ~~Provider~~Owners' and the CAISO's Transmission ~~System~~Systems.

Notice of Dispute shall mean a written notice of a dispute or claim that arises out of or in connection with ~~the Standard Large Generator Interconnection~~this Agreement or its performance.

~~**Optional Interconnection Study** shall mean a sensitivity analysis based on assumptions specified by the Interconnection Customer in the Optional Interconnection Study Agreement.~~

Operating Agent of the JPP shall mean APS as the entity designated as the operating agent of the JPP pursuant to the Participation Agreement.

~~_____ **Optional Interconnection Study Agreement** shall mean the form of agreement contained in Appendix 5 of the Standard Large Generator Interconnection Procedures for conducting the Optional Interconnection Study.~~

_____ **Ownership Interests** shall mean the ownership interests of APS, IID and SDG&E in the JPP, as set forth in the Participation Agreement, as amended, and for purposes of this Agreement, APS, 11 percent; IID, 12.78 percent; and SDG&E, 76.22 percent.

Party or Parties shall mean Transmission ~~Provider, Transmission~~ Owner(s), the CAISO, Interconnection Customer or ~~any~~the applicable combination of the above.

Phase I Interconnection Study shall have the meaning set forth in the CAISO Tariff as of the effective date of this Agreement.

Phase II Interconnection Study shall have the meaning set forth in the CAISO Tariff as of the effective date of this Agreement.

Phase A of the Generating Facility shall mean no more than 290 MW (net) of solar photovoltaic units installed at the site of the Generating Facility, as described in Appendix C.

Phase B of the Generating Facility shall mean no more than 210 MW (net) of solar photovoltaic units installed at the site of the Generating Facility, as described in Appendix C, after Phase A of the Generating Facility has been completed.

Phase A of the Interconnection Project shall mean construction of the Interconnection Facilities and Network Upgrades required to interconnect Phase A of the Generating Facility, as described in Appendix A-1.

Phase B of the Interconnection Project shall mean construction of the Interconnection Facilities and Network Upgrades required to interconnect Phase B of the Generating Facility, as described in Appendices A-2 and A-3 and as may be identified in studies provided for in Appendix C.

Point of Change of Ownership shall mean the point, as set forth in ~~Appendix A to the Standard Large Generator Interconnection~~Appendices A-1 and A-2 to this Agreement, where the Interconnection Customer's Interconnection Facilities connect to the Transmission ~~Provider's~~Owners' Interconnection Facilities.

Point of Interconnection shall mean the point, as set forth in ~~Appendix A to the Standard Large Generator Interconnection~~Appendices A-1 and A-2 to this Agreement, where the Interconnection Facilities connect to the ~~Transmission Provider's Transmission System~~JPP.

Project Block shall mean a portion of the solar photovoltaic units within a Project Phase as described in Appendix B-1 and B-2.

Project Phase shall mean either Phase A of the Generating Facility or Phase B of the Generating Facility.

Queue Position shall mean the order of a valid Interconnection Request, relative to all other pending valid Interconnection Requests, that is established based upon the date and time of receipt of the valid Interconnection Request by ~~the Transmission Provider~~APS or the CAISO under its Tariff.

Reasonable Efforts shall mean, with respect to an action required to be attempted or taken by a Party under ~~the Standard Large Generator Interconnection~~this Agreement, efforts that are timely and consistent with Good Utility Practice and are otherwise substantially equivalent to those a Party would use to protect its own interests.

Scoping Meeting shall mean the ~~meeting~~meetings between representatives of the Interconnection Customer and Transmission ~~Provider~~Owners and the CAISO conducted for the purpose of discussing alternative interconnection options, to exchange information including any transmission data and earlier study evaluations that would be reasonably expected to impact such interconnection options, to analyze such information, and to determine the potential feasible Points of Interconnection.

Site Control shall mean documentation reasonably demonstrating: (1) ownership of, a leasehold interest in, or a right to develop a site for the purpose of constructing the Generating Facility; (2) an option to purchase or acquire a leasehold site for such purpose; or (3) an exclusivity or other business relationship between Interconnection Customer and the entity having the right to sell, lease or grant Interconnection Customer the right to possess or occupy a site for such purpose.

Small Generating Facility shall mean a Generating Facility that has a Generating Facility Capacity of no more than 20 MW.

Stand Alone Network Upgrades shall mean Network Upgrades that an Interconnection Customer may construct without affecting day-to-day operations of the Transmission System during their construction. ~~Both the~~The Transmission ~~Provider~~Owners, the CAISO and the Interconnection Customer must agree as to what constitutes Stand Alone Network Upgrades and identify them in ~~Appendix A to the Standard Large Generator Interconnection~~Appendices A-1, A-2, and A-3 to this Agreement.

~~Standard Large Generator Interconnection Agreement (LGIA) shall mean the form of interconnection agreement applicable to an Interconnection Request pertaining to a Large Generating Facility that is included in the Transmission Provider's Tariff. Standard Large Generator Interconnection Procedures (LGIP) shall mean the interconnection procedures applicable to an Interconnection Request pertaining to a Large Generating Facility that are included in the Transmission Provider's Tariff.~~

System Protection Facilities shall mean the equipment, including necessary protection signal communications equipment, ~~required to protect~~that protects (1) the Transmission ~~Provider~~Owners' and the CAISO's Transmission ~~System~~Systems from faults or other electrical disturbances occurring at the Generating Facility and (2) the Generating Facility from faults or other electrical system disturbances occurring on the Transmission ~~Provider~~Owners' and the CAISO's Transmission ~~System~~Systems or on other delivery systems or other generating systems to which the Transmission ~~Provider~~Owners' and the CAISO's Transmission ~~System is~~Systems are directly connected.

Tariff shall mean the ~~Transmission Provider's Tariff~~APS, IID, SDG&E or CAISO tariffs through which open access transmission service and Interconnection Service are offered, as filed with FERC with respect to FERC-jurisdictional public utilities and as posted with respect to IID, and as amended or supplemented from time to time, or any successor tariff.

Transmission Owner(s) shall mean ~~an entity that owns, leases or otherwise possesses an interest in the portion of the Transmission System~~APS, IID and SDG&E, as joint owners of the JPP at the Point of Interconnection ~~and may be a Party to the Standard Large Generator~~

~~Interconnection Agreement to the extent necessary.~~ Pursuant to the Participation Agreement, APS is Operating Agent of the JPP and acts on behalf of the Transmission Owners with respect to the JPP.

~~Transmission Provider shall mean the public utility (or its designated agent) that owns, controls, or operates transmission or distribution facilities used for the transmission of electricity in interstate commerce and provides transmission service under the Tariff. The term Transmission Provider should be read to include the Transmission Owner when the Transmission Owner is separate from the Transmission Provider.~~

~~Transmission Provider's~~ Transmission Owners' Interconnection Facilities shall mean all facilities and equipment owned, controlled or operated by the Transmission ~~Provider~~Owners from the Point of Change of Ownership identified in Appendices A-1 and A-2 to the Point of Interconnection as identified in ~~Appendix A to the Standard Large Generator Interconnection~~Appendices A-1 and A-2 to this Agreement, including any modifications, additions or upgrades to such facilities and equipment. Transmission ~~Provider's~~Owners' Interconnection Facilities are sole use facilities and shall not include Distribution Upgrades, Stand Alone Network Upgrades or Network Upgrades.

Transmission System shall mean the facilities, including the portion of the JPP, owned, controlled or operated by ~~the Transmission Provider or~~ Transmission Owner or the CAISO that are used to provide transmission service under the respective Tariff.

Trial Operation shall mean the period during which Interconnection Customer is engaged in on-site test operations and commissioning of the ~~Generating Facility~~first Project Block of each Project Phase prior to Commercial Operation.

Article 2. Effective Date, Term, and Termination

2.1 **Effective Date.** ~~This LGIA~~Except as provided below with respect to IID, this Agreement shall become effective upon execution by the Parties ~~subject to~~and acceptance for filing by FERC (~~if applicable~~), or if filed unexecuted under Section 205 of the Federal Power Act, upon the date specified by FERC. ~~for the Transmission Owners that are FERC-jurisdictional public utilities and the CAISO. Such~~ Transmission ~~Provider~~Owners and the CAISO shall promptly ~~file~~submit this ~~LGIA~~Agreement for filing with FERC upon execution in accordance with Article ~~3.1, if required~~3.1. The Parties acknowledge that IID is not a public utility subject to FERC's jurisdiction under Section 205 or 206 of the Federal Power Act. Therefore, as applied to IID, the Effective Date for the Agreement shall not commence until the later of the date the Agreement is executed by IID, either voluntarily or pursuant to a lawful order issued by FERC in accordance with Sections 210 and 212 of the Federal Power Act, and the date the Agreement is accepted for filing with regard to the Transmission Owners that are FERC-jurisdictional and the CAISO.

2.2 **Term of Agreement.** Subject to the provisions of Article 2.3, this ~~LGIA~~Agreement shall remain in effect for a period of ~~ten~~forty (~~10~~40) years from the Effective Date ~~or such other longer period as Interconnection Customer may request (Term to be specified in individual agreements)~~ and shall be automatically renewed for each successive one-year period thereafter.

2.3 Termination Procedures.

- 2.3.1 **Written Notice.** This LGIA Agreement may be terminated by (i) Interconnection Customer after giving ~~Transmission Provider~~all other Parties ninety (90) Calendar Days advance written notice, or (ii) by APS, on behalf of the Transmission Provider Owners, or the CAISO notifying FERC after the Generating Facility permanently ceases Commercial Operation. Notice of termination by the Interconnection Customer must be provided by both of the entities comprising the Interconnection Customer.
- 2.3.2 **Default.** ~~Either~~A Party may terminate this LGIA Agreement in accordance with Article 17.
- 2.3.3 Notwithstanding Articles 2.3.1 and 2.3.2, no termination shall become effective until the Parties have complied with all Applicable Laws and Regulations applicable to such termination, including ~~the~~any required filing with FERC of a notice of termination of this LGIA Agreement, which notice has been accepted for filing by FERC. For clarity and avoidance of ambiguity, IID is not a jurisdictional public utility required to file a notice of termination under Section 205 or 206 of the Federal Power Act prior to terminating its participation in this Agreement in accordance with the terms of such Agreement.

2.4 Termination Costs. ~~If a Party elects to terminate~~

Upon receipt of a notice of the termination of this Agreement pursuant to Article 2.3 above, ~~each Party shall pay~~the Transmission Owners and the CAISO will promptly determine the total cost responsibility of the Interconnection Customer. If, as of the date of receipt of such notice of termination, the Interconnection Customer has not already paid its share of Network Upgrade costs, including those set forth in Appendices A-1, A-2, and A-3, APS, as the Operating Agent of the JPP, will enforce the financial security rights of APS and IID pursuant to this Agreement and SDG&E will cause Interconnection Customer's Interconnection Financial Security associated with its cost responsibility for SDG&E's non-JPP Network Upgrades and SDG&E's share of the JPP Network Upgrades set forth in Appendices A-1, A-2, and A-3 to be liquidated, in accordance with Section 9.4 of the CAISO's Large Generator Interconnection Procedures.

The Interconnection Customer will also be responsible for all costs incurred or irrevocably committed to be incurred in association with the construction of the Transmission Owners' Interconnection Facilities (including any cancellation costs relating to orders or contracts for Interconnection Facilities and equipment) or charges assessed by the other Party, as of the date of the other Party's receipt of such notice of termination, that are the responsibility of the Terminating Party under this LGIA. In and other such expenses for which the Transmission Owners or the CAISO have incurred expenses or have irrevocably committed to incur expenses and have not been reimbursed by the Interconnection Customer, as of the date of receipt of the notice of termination, subject to the limitations set forth in this Article 2.4. Nothing in this Article 2.4 shall

limit the Parties' rights under Article 17. If, as of the date of the receipt of the notice of termination, the Interconnection Customer has not already reimbursed the Transmission Owners and the CAISO for costs incurred to construct the Transmission Owners' Interconnection Facilities, APS, as Operating Agent of the JPP, shall enforce the financial security rights of APS and IID pursuant to this Agreement and SDG&E will liquidate the Interconnection Customer's Interconnection Financial Security associated with the construction of SDG&E's share of the Transmission Owners' Interconnection Facilities, in accordance with Section 9.4 of the CAISO Large Generator Interconnection Procedures.

For cost responsibility for Interconnection Facilities and Network Upgrades to the JPP set forth in Appendices A-1 and A-2, the Transmission Owners' financial security rights shall be enforced in accordance with the provisions for enforcement of financial security set forth in Appendices A-1 and A-2.

If the amount of the financial security, including the Interconnection Financial Security, liquidated by Transmission Owners under this Article 2.4 is insufficient to compensate Transmission Owners and the CAISO for actual costs associated with the construction of the Transmission Owners' Interconnection Facilities and Network Upgrades contemplated in this Article, any additional amounts will be the responsibility of the Interconnection Customer. Any such additional amounts due from the Interconnection Customer beyond the amounts covered by its financial security, including its Interconnection Financial Security, will be due to the Transmission Owners immediately upon termination of this Agreement, subject, with respect to amounts due SDG&E, to the provisions of Section 9.4 of the CAISO Large Generator Interconnection Procedures.

If the amount of the Interconnection Financial Security exceeds the Interconnection Customer's cost responsibility under Section 9.4 of the CAISO's Large Generator Interconnection Procedures, such excess amount will be released to the Interconnection Customer by SDG&E in accordance with Section 9.4 of the CAISO's Large Generator Interconnection Procedures.

Notwithstanding the foregoing, in the event of termination ~~by a Party~~ of this Agreement, the Parties shall use commercially Reasonable Efforts to mitigate the costs, damages and charges arising as a consequence of termination. Upon termination of this ~~LGIA~~ Agreement, unless otherwise ordered or approved by FERC to the extent FERC possesses jurisdiction over the public utilities which are Parties to this Agreement:

2.4.1 With respect to any portion of Transmission ~~Provider's~~ Owners' Interconnection Facilities that have not yet been constructed or installed, Transmission ~~Provider~~ Owners shall to the extent possible and with Interconnection Customer's authorization cancel any pending orders of, or return, any materials or equipment for, or contracts for construction of, such ~~facilities~~ Interconnection Facilities; provided that in the event Interconnection Customer elects not to authorize such cancellation, Interconnection Customer shall assume all payment obligations with respect to such materials, equipment, and contracts, and Transmission ~~Provider~~ Owners shall deliver such material and equipment, and, if necessary, assign such contracts, to Interconnection Customer as soon as practicable, at

Interconnection Customer's expense. To the extent that Interconnection Customer has already paid Transmission ~~Provider~~Owners for any or all such costs of materials or equipment not taken by Interconnection Customer, Transmission ~~Provider~~Owners shall promptly refund such amounts to Interconnection Customer, less any costs, including penalties incurred by Transmission ~~Provider~~Owners to cancel any pending orders of or return such materials, equipment, or contracts.

~~If an Interconnection Customer terminates this LGIA, it shall be responsible for all costs incurred in association with that Interconnection Customer's interconnection, including any cancellation costs relating to orders or contracts for Interconnection Facilities and equipment, and other expenses including any Network Upgrades for which Transmission Provider has incurred expenses and has not been reimbursed by Interconnection Customer.~~

2.4.2 Transmission ~~Provider~~Owners may, at ~~its~~their collective option, retain any portion of such materials, equipment, or facilities that Interconnection Customer chooses not to accept delivery of, in which case Transmission ~~Provider~~Owners shall be responsible for all costs associated with procuring such materials, equipment, or facilities.

2.4.3 With respect to any portion of the Interconnection Facilities, and any other facilities already installed or constructed pursuant to the terms of this ~~LGIA~~Agreement, Interconnection Customer shall be responsible for all costs associated with the removal, relocation or other disposition or retirement of such materials, equipment, or facilities.

2.5 **Disconnection.** Upon termination of this ~~LGIA, the Parties~~Agreement as to Phase A of the Interconnection Project, APS, on behalf of Transmission Owners, will take all appropriate steps to disconnect ~~the Large Generating Facility~~Phase A of the Interconnection Project from the ~~Transmission System~~JPP. All costs required to effectuate such disconnection shall be borne by the terminating Party, unless such termination resulted from the non-terminating Party's Default of this ~~LGIA~~Agreement or such non-terminating Party otherwise is responsible for these costs under this ~~LGIA~~Agreement.

Upon termination of this Agreement as to Phase B of the Interconnection Project, APS, on behalf of Transmission Owners will take all appropriate steps to disconnect Phase B of the Interconnection Project from the JPP. All costs required to effectuate such disconnection shall be borne by the terminating Party, unless such termination resulted from the non-terminating Party's Default of this Agreement or such non-terminating Party otherwise is responsible for these costs under this Agreement.

2.6 **Survival.** This ~~LGIA~~Agreement shall continue in effect after termination to the extent necessary to provide for final billings and payments and for costs incurred hereunder, including billings and payments pursuant to this ~~LGIA~~Agreement; to permit the determination and enforcement of liability and indemnification obligations arising from acts or events that occurred while this ~~LGIA~~Agreement was in effect; and to permit ~~each~~

~~Party~~ the Parties to have access to the lands of ~~the other~~ another Party pursuant to this LGIA Agreement or other applicable agreements, to disconnect, remove or salvage its own facilities and equipment.

Article 3. Regulatory Filings

3.1 **Filing.** The CAISO and Transmission ~~Provider~~ Owners that are FERC-jurisdictional public utilities shall file this LGIA Agreement (and any amendment hereto) with the appropriate Governmental Authority, if required. Interconnection Customer may request that any information so provided be subject to the confidentiality provisions of Article 22. If Interconnection Customer has executed this LGIA Agreement, or any amendment thereto, Interconnection Customer shall reasonably cooperate with Transmission ~~Provider~~ Owners and the CAISO with respect to such filing and to provide any information reasonably requested by Transmission ~~Provider~~ Owners and the CAISO needed to comply with applicable regulatory requirements. For clarity and avoidance of ambiguity, IID is not a jurisdictional public utility subject to a filing requirement under Section 205 of the Federal Power Act.

Article 4. Scope of Service

4.1 **Interconnection Product Options.** Interconnection Customer has selected ~~the following (checked) type of~~ Energy Resource Interconnection Service: from APS to interconnect to the APS Transmission System and IID's share of the JPP, and Interconnection Service from the CAISO.

4.1.1 CAISO Interconnection Service. Interconnection Service provided by the CAISO and SDG&E allows the Interconnection Customer to connect the Large Generating Facility to the CAISO's Transmission System and be eligible to deliver the Large Generating Facility's output using the available capacity of the CAISO's Transmission System pursuant to the CAISO Tariff.

Interconnection Service does not necessarily provide the Interconnection Customer with the capability to physically deliver the output of its Large Generating Facility to any particular load on the CAISO Transmission System without incurring congestion costs. In the event of transmission constraints on the CAISO Transmission System, the Interconnection Customer's Large Generating Facility shall be subject to the applicable congestion management procedures in the CAISO Tariff in the same manner as all other resources.

~~4.1.1~~ 4.1.2 **Energy Resource Interconnection Service.**

~~4.1.1~~ 4.1.2.1 **The Product.** Energy Resource Interconnection Service from APS and IID allows Interconnection Customer to connect the Large Generating Facility to the ~~Transmission System~~ JPP and be eligible to deliver the Large Generating Facility's output using available capacity on the existing firm or non-firm capacity of the APS Transmission System and IID's share of the JPP on an "as available" basis. ~~To the extent Interconnection Customer wants to receive Energy Resource~~

~~Interconnection Service, Transmission Provider shall construct facilities identified in Attachment A.~~

~~4.1.1.24.1.2.2~~ **Transmission Delivery Service Implications.** Under Energy Resource Interconnection Service, Interconnection Customer will be eligible to inject power from the Large Generating Facility into and deliver power across the ~~interconnecting Transmission Provider's~~ APS Transmission System and IID's share of the JPP on an "as available" basis up to the amount of MWs identified in the applicable stability and steady state studies to the extent the upgrades initially required to qualify for Energy Resource Interconnection Service have been constructed. ~~Where eligible to do so (e.g., PJM, ISO-NE, NYISO), Interconnection Customer may place a bid to sell into the market up to the maximum identified Large Generating Facility output, subject to any conditions specified in the interconnection service approval, and the Large Generating Facility will be dispatched to the extent Interconnection Customer's bid clears. In all other instances, no~~ No transmission delivery service from the Large Generating Facility is assured, but Interconnection Customer may obtain Point-to-Point Transmission Service, Network Integration Transmission Service, or be used for secondary network transmission service, pursuant to the APS Tariff or Transmission Provider's Service on IID's share of the JPP pursuant to the IID Tariff, up to the maximum output identified in the stability and steady state studies. ~~In those instances, in~~ order for Interconnection Customer to obtain the right to deliver or inject energy beyond the Large Generating Facility Point of Interconnection or to improve its ability to do so, transmission delivery service must be obtained pursuant to the provisions of ~~Transmission Provider's Tariff~~ the APS or IID Tariffs. The Interconnection Customer's ability to inject its Large Generating Facility output beyond the Point of Interconnection, therefore, will depend on the existing capacity of the APS or IID Transmission Provider's Transmission System ~~Systems~~ at such time as a transmission service request is made that would accommodate such delivery. The provision of firm Point-to-Point Transmission Service or Network Integration Transmission Service may require the construction of additional Network Upgrades.

~~4.1.2 Network Resource Interconnection Service,~~ 4.1.3 Network Resource Interconnection Service.

~~4.1.2.1 The Product.~~ ~~Transmission Provider must conduct the necessary studies and construct the Network Upgrades needed to integrate the Large Generating Facility (1) in a manner comparable to that in which Transmission Provider integrates its generating facilities to serve native load customers; or (2) in an ISO or RTO with market based congestion management, in the same manner as all Network Resources. To the extent Interconnection Customer wants to receive Network Resource Interconnection Service,~~

Transmission Provider shall construct the facilities identified in Attachment A to this LGIA.

4.1.3.1 The Product. [THIS SECTION IS NOT APPLICABLE TO THIS AGREEMENT.]

~~4.1.2.2 Transmission Delivery Service Implications. Network Resource Interconnection Service allows Interconnection Customer's Large Generating Facility to be designated by any Network Customer under the Tariff on Transmission Provider's Transmission System as a Network Resource, up to the Large Generating Facility's full output, on the same basis as existing Network Resources interconnected to Transmission Provider's Transmission System, and to be studied as a Network Resource on the assumption that such a designation will occur. Although Network Resource Interconnection Service does not convey a reservation of transmission service, any Network Customer under the Tariff can utilize its network service under the Tariff to obtain delivery of energy from the interconnected Interconnection Customer's Large Generating Facility in the same manner as it accesses Network Resources. A Large Generating Facility receiving Network Resource Interconnection Service may also be used to provide Ancillary Services after technical studies and/or periodic analyses are performed with respect to the Large Generating Facility's ability to provide any applicable Ancillary Services, provided that such studies and analyses have been or would be required in connection with the provision of such Ancillary Services by any existing Network Resource. However, if an Interconnection Customer's Large Generating Facility has not been designated as a Network Resource by any load, it cannot be required to provide Ancillary Services except to the extent such requirements extend to all generating facilities that are similarly situated. The provision of Network Integration Transmission Service or firm Point to Point Transmission Service may require additional studies and the construction of additional upgrades. Because such studies and upgrades would be associated with a request for delivery service under the Tariff, cost responsibility for the studies and upgrades would be in accordance with FERC's policy for pricing transmission delivery services.~~

Network Resource Interconnection Service does not necessarily provide Interconnection Customer with the capability to physically deliver the output of its Large Generating Facility to any particular load on Transmission Provider's Transmission System without incurring congestion costs. In the event of transmission constraints on Transmission Provider's Transmission System, Interconnection Customer's Large Generating Facility shall be subject to the applicable congestion management procedures in Transmission Provider's Transmission System in the same manner as Network Resources.

~~There is no requirement either at the time of study or interconnection, or at any point in the future, that Interconnection Customer's Large Generating Facility be designated as a Network Resource by a Network Service Customer under the Tariff or that Interconnection Customer identify a specific buyer (or sink). To the extent a Network Customer does designate the Large Generating Facility as a Network Resource, it must do so pursuant to Transmission Provider's Tariff.~~

~~Once an Interconnection Customer satisfies the requirements for obtaining Network Resource Interconnection Service, any future transmission service request for delivery from the Large Generating Facility within Transmission Provider's Transmission System of any amount of capacity and/or energy, up to the amount initially studied, will not require that any additional studies be performed or that any further upgrades associated with such Large Generating Facility be undertaken, regardless of whether or not such Large Generating Facility is ever designated by a Network Customer as a Network Resource and regardless of changes in ownership of the Large Generating Facility. However, the reduction or elimination of congestion or redispatch costs may require additional studies and the construction of additional upgrades.~~

~~To the extent Interconnection Customer enters into an arrangement for long term transmission service for deliveries from the Large Generating Facility outside Transmission Provider's Transmission System, such request may require additional studies and upgrades in order for Transmission Provider to grant such request.~~

4.1.3.2 Transmission Delivery Service Implications. [THIS SECTION IS NOT APPLICABLE TO THIS AGREEMENT.]

- 4.2 **Provision of Service.** APS, on behalf of the Transmission ~~Provider~~ Owners, and the CAISO shall provide Interconnection Service for the Large Generating Facility at the Point of Interconnection.
- 4.3 **Performance Standards.** Each Party shall perform all of its obligations under this LGIA Agreement in accordance with Applicable Laws and Regulations, Applicable Reliability Standards, and Good Utility Practice, and to the extent a Party is required or prevented or limited in taking any action by such regulations and standards, such Party shall not be deemed to be in Breach of this LGIA Agreement for its compliance therewith. If such Party is a Transmission ~~Provider or Transmission~~ Owner or the CAISO, then that Party shall ~~amend the LGIA and~~ negotiate an amendment to the Agreement and, if it is a FERC-jurisdictional public utility, shall submit the amendment to FERC for approval. For clarity and avoidance of ambiguity, IID is not a FERC-jurisdictional public utility subject to a filing requirement under Section 205 of the Federal Power Act.
- 4.4 **No Transmission Delivery Service.** The execution of this LGIA Agreement does not constitute a request for, nor the provision of, any transmission delivery service under

~~Transmission Provider's~~any applicable Tariff, and does not convey any right to deliver electricity to any specific customer or ~~Pointpoint~~ of ~~Delivery~~delivery.

- 4.5 **Interconnection Customer Provided Services.** The services provided by Interconnection Customer under this ~~LGIA~~Agreement are set forth in Article 9.6 and Article 13.5.1. Interconnection Customer shall be paid for such services in accordance with Article 11.6.

Article 5. **Interconnection Facilities Engineering, Procurement, and Construction**

- 5.1 **Options.** Unless otherwise mutually agreed to between the Parties, Interconnection Customer shall select the In-Service Date, Initial Synchronization Date, and Commercial Operation Date; and either Standard Option or Alternate Option set forth below for completion of Transmission ~~Provider's~~Owners' Interconnection Facilities and Network Upgrades as set forth in ~~Appendix A, Interconnection Facilities and Network Upgrades,~~Appendices A-1, A-2, and A-3, and such dates and selected option shall be set forth in ~~Appendix B, Appendices B-1, B-2, and B-3~~ Milestones.

5.1.1 **Standard Option.** APS, on behalf of Transmission ~~Provider~~Owners shall design, procure, and construct Transmission ~~Provider's~~Owners' Interconnection Facilities and ~~JPP~~ Network Upgrades; set forth in Appendices A-1 and A-2, and SDG&E shall design, procure, and construct Network Upgrades set forth in Appendix A-3, in each case using Reasonable Efforts to complete the Transmission ~~Provider's~~Owners' Interconnection Facilities and these Network Upgrades by the dates set forth in ~~Appendix B, Appendices B-1, B-2, and B-3~~ Milestones. Transmission ~~Provider~~Owners shall not be required to undertake any action which is inconsistent with ~~its~~their standard safety practices, ~~its~~ material and equipment specifications, ~~its~~ design criteria and construction procedures, ~~its~~ labor agreements, and Applicable Laws and Regulations. In the event APS, on behalf of Transmission ~~Provider~~Owners, and/or SDG&E, as applicable, reasonably ~~expects~~expect that ~~it~~they will not be able to complete Transmission ~~Provider's~~Owners' Interconnection Facilities and Network Upgrades set forth in Appendices A-1, A-2, and A-3 by the specified dates; in the Appendices B-1, B-2, and B-3 Milestones, APS, on behalf of Transmission ~~Provider~~Owners, and/or SDG&E, as applicable, shall promptly provide written notice to Interconnection Customer and shall undertake Reasonable Efforts to meet the earliest dates thereafter.

~~5.1.2—Alternate Option. If the dates designated by Interconnection Customer are acceptable to Transmission Provider, Transmission Provider shall so notify Interconnection Customer within thirty (30) Calendar Days, and shall assume responsibility for the design, procurement and construction of Transmission Provider's Interconnection Facilities by the designated dates.~~

~~If Transmission Provider subsequently fails to complete Transmission Provider's Interconnection Facilities by the In-Service Date, to the extent necessary to provide back feed power; or fails to complete Network Upgrades by the Initial Synchronization Date to the extent necessary to allow for Trial Operation at full~~

~~power output, unless other arrangements are made by the Parties for such Trial Operation; or fails to complete the Network Upgrades by the Commercial Operation Date, as such dates are reflected in Appendix B, Milestones; Transmission Provider shall pay Interconnection Customer liquidated damages in accordance with Article 5.3, Liquidated Damages, provided, however, the dates designated by Interconnection Customer shall be extended day for day for each day that the applicable RTO or ISO refuses to grant clearances to install equipment.~~

~~**5.1.2** Alternate Option. [THIS SECTION IS NOT APPLICABLE TO THIS AGREEMENT.]~~

~~**5.1.3** **Option to Build.** If the dates designated by Interconnection Customer are not acceptable to Transmission Provider, Transmission Provider shall so notify Interconnection Customer within thirty (30) Calendar Days, and unless the Parties agree otherwise, Interconnection Customer shall have the option to assume responsibility for the design, procurement and construction of Transmission Provider's Interconnection Facilities and Stand Alone Network Upgrades on the dates specified in Article 5.1.2. Transmission Provider and Interconnection Customer must agree as to what constitutes Stand Alone Network Upgrades and identify such Stand Alone Network Upgrades in Appendix A. Except for Stand Alone Network Upgrades, Interconnection Customer shall have no right to construct Network Upgrades under this option.~~

~~**5.1.3** Option to Build. [THIS SECTION IS NOT APPLICABLE TO THIS AGREEMENT.]~~

~~**5.1.4** **Negotiated Option.** If Interconnection Customer elects not to exercise its option under Article 5.1.3, Option to Build, Interconnection Customer shall so notify Transmission Provider within thirty (30) Calendar Days, and the Parties shall in good faith attempt to negotiate terms and conditions (including revision of the specified dates and liquidated damages, the provision of incentives or the procurement and construction of a portion of Transmission Provider's Interconnection Facilities and Stand Alone Network Upgrades by Interconnection Customer) pursuant to which Transmission Provider is responsible for the design, procurement and construction of Transmission Provider's Interconnection Facilities and Network Upgrades. If the Parties are unable to reach agreement on such terms and conditions, Transmission Provider shall assume responsibility for the design, procurement and construction of Transmission Provider's Interconnection Facilities and Network Upgrades pursuant to 5.1.1, Standard Option.~~

~~**5.1.4** Negotiated Option. [THIS SECTION IS NOT APPLICABLE TO THIS AGREEMENT.]~~

~~**5.2** **General Conditions Applicable to Option to Build.** If Interconnection Customer assumes responsibility for the design, procurement and construction of Transmission Provider's~~

~~Interconnection Facilities and Stand Alone Network Upgrades; [\[THIS SECTION IS NOT APPLICABLE TO THIS AGREEMENT.\]](#)~~

~~(1) Interconnection Customer shall engineer, procure equipment, and construct Transmission Provider's Interconnection Facilities and Stand Alone Network Upgrades (or portions thereof) using Good Utility Practice and using standards and specifications provided in advance by Transmission Provider;~~

~~(2) Interconnection Customer's engineering, procurement and construction of Transmission Provider's Interconnection Facilities and Stand Alone Network Upgrades shall comply with all requirements of law and Applicable Reliability Standards to which Transmission Provider would be subject in the engineering, procurement or construction of Transmission Provider's Interconnection Facilities and Stand Alone Network Upgrades;~~

~~(3) Transmission Provider shall review and approve the engineering design, equipment acceptance tests, and the construction of Transmission Provider's Interconnection Facilities and Stand Alone Network Upgrades;~~

~~(4) prior to commencement of construction, Interconnection Customer shall provide to Transmission Provider a schedule for construction of Transmission Provider's Interconnection Facilities and Stand Alone Network Upgrades, and shall promptly respond to requests for information from Transmission Provider;~~

~~(5) at any time during construction, Transmission Provider shall have the right to gain unrestricted access to Transmission Provider's Interconnection Facilities and Stand Alone Network Upgrades and to conduct inspections of the same;~~

~~(6) at any time during construction, should any phase of the engineering, equipment procurement, or construction of Transmission Provider's Interconnection Facilities and Stand Alone Network Upgrades not meet the standards and specifications provided by Transmission Provider, Interconnection Customer shall be obligated to remedy deficiencies in that portion of Transmission Provider's Interconnection Facilities and Stand Alone Network Upgrades;~~

~~(7) Interconnection Customer shall indemnify Transmission Provider for claims arising from Interconnection Customer's construction of Transmission Provider's Interconnection Facilities and Stand Alone Network Upgrades under the terms and procedures applicable to Article 18.1 Indemnity;~~

~~(8) Interconnection Customer shall transfer control of Transmission Provider's Interconnection Facilities and Stand Alone Network Upgrades to Transmission Provider;~~

~~(9) Unless Parties otherwise agree, Interconnection Customer shall transfer ownership of Transmission Provider's Interconnection Facilities and Stand Alone Network Upgrades to Transmission Provider;~~

~~(10) Transmission Provider shall approve and accept for operation and maintenance Transmission Provider's Interconnection Facilities and Stand-Alone Network Upgrades to the extent engineered, procured, and constructed in accordance with this Article 5.2; and~~

~~(11) Interconnection Customer shall deliver to Transmission Provider "as-built" drawings, information, and any other documents that are reasonably required by Transmission Provider to assure that the Interconnection Facilities and Stand-Alone Network Upgrades are built to the standards and specifications required by Transmission Provider.~~

~~**5.3 — Liquidated Damages.** The actual damages to Interconnection Customer, in the event Transmission Provider's Interconnection Facilities or Network Upgrades are not completed by the dates designated by Interconnection Customer and accepted by Transmission Provider pursuant to subparagraphs 5.1.2 or 5.1.4, above, may include Interconnection Customer's fixed operation and maintenance costs and lost opportunity costs. Such actual damages are uncertain and impossible to determine at this time. Because of such uncertainty, any liquidated damages paid by Transmission Provider to Interconnection Customer in the event that Transmission Provider does not complete any portion of Transmission Provider's Interconnection Facilities or Network Upgrades by the applicable dates, shall be an amount equal to ½ of 1 percent per day of the actual cost of Transmission Provider's Interconnection Facilities and Network Upgrades, in the aggregate, for which Transmission Provider has assumed responsibility to design, procure and construct.~~

~~However, in no event shall the total liquidated damages exceed 20 percent of the actual cost of Transmission Provider's Interconnection Facilities and Network Upgrades for which Transmission Provider has assumed responsibility to design, procure, and construct. The foregoing payments will be made by Transmission Provider to Interconnection Customer as just compensation for the damages caused to Interconnection Customer, which actual damages are uncertain and impossible to determine at this time, and as reasonable liquidated damages, but not as a penalty or a method to secure performance of this LGIA. Liquidated damages, when the Parties agree to them, are the exclusive remedy for the Transmission Provider's failure to meet its schedule.~~

~~No liquidated damages shall be paid to Interconnection Customer if: (1) Interconnection Customer is not ready to commence use of Transmission Provider's Interconnection Facilities or Network Upgrades to take the delivery of power for the Large Generating Facility's Trial Operation or to export power from the Large Generating Facility on the specified dates, unless Interconnection Customer would have been able to commence use of Transmission Provider's Interconnection Facilities or Network Upgrades to take the delivery of power for Large Generating Facility's Trial Operation or to export power from the Large Generating Facility, but for Transmission Provider's delay; (2) Transmission Provider's failure to meet the specified dates is the result of the action or inaction of Interconnection Customer or any other Interconnection Customer who has entered into an LGIA with Transmission Provider or any cause beyond Transmission Provider's~~

~~reasonable control or reasonable ability to cure; (3) the Interconnection Customer has assumed responsibility for the design, procurement and construction of Transmission Provider's Interconnection Facilities and Stand Alone Network Upgrades; or (4) the Parties have otherwise agreed.~~

5.3 Liquidated Damages. [THIS SECTION IS NOT APPLICABLE TO THIS AGREEMENT.]

5.4 Power System Stabilizers. ~~The~~If the Applicable Reliability Standards, or the guidelines and procedures established by the Applicable Reliability Council, deem a Power System Stabilizer applicable to the type of solar photovoltaic equipment used in the Generating Facility, then the Interconnection Customer shall procure, install, maintain and operate Power System Stabilizers ~~in accordance with the guidelines and procedures established by the Applicable Reliability Council. Transmission Provider.~~ APS reserves the right to reasonably establish minimum acceptable settings for any installed Power System Stabilizers, subject to the design and operating limitations of the Large Generating Facility. If the Large Generating Facility's Power System Stabilizers are removed from service or not capable of automatic operation, Interconnection Customer shall immediately notify Transmission Provider's system operator, or its designated representative. The requirements of this paragraph shall not apply to wind generators APS and restore the Power System Stabilizers to operation as soon as possible. APS shall have the right to order the reduction in output or disconnection of the Large Generating Facility if the reliability of the Transmission System would be adversely affected as a result of improperly tuned Power System Stabilizers. The Generating Facility is a solar photovoltaic generator and as such does not have the physical characteristic to which a Power System Stabilizer would apply.

5.5 Equipment Procurement. ~~If responsibility for construction~~The Transmission Owners' design of Transmission ~~Provider's~~Owners' Interconnection Facilities ~~or~~and Network Upgrades ~~is to be borne by Transmission Provider, then Transmission Provider shall commence design of Transmission Provider's~~to the JPP for Phase A of the Interconnection Project, as set forth in Appendix A-1, and partial procurement of certain long-lead equipment for Phase A of the Interconnection Project has been advanced in accordance with the terms of the E & P Agreement dated March 30, 2010. To the extent the design and long lead time procurement work has not been completed pursuant to the E&P Agreement, APS, on behalf of Transmission Owners, shall finish design of Transmission Owners' Interconnection Facilities or and Network Upgrades to the JPP and procure necessary equipment as soon as practicable after all of the following additional conditions are satisfied, unless the Parties otherwise agree in writing: pursuant to the terms of this Agreement.

~~5.5.1—Transmission Provider has completed the Facilities Study pursuant to the Facilities Study Agreement;~~

~~5.5.2—Transmission Provider has received written authorization to proceed with design and procurement from Interconnection Customer by the date specified in Appendix B, Milestones; and~~

~~5.5.3—Interconnection Customer has provided security to Transmission Provider in accordance with Article 11.5 by the dates specified in Appendix B, Milestones.~~

5.6 Construction Commencement. ~~Transmission Provider shall commence construction of Transmission Provider's Interconnection Facilities and Network Upgrades for which it is responsible~~ APS, on behalf of Transmission Owners, shall commence construction of Transmission Owners' Interconnection Facilities and Network Upgrades to the JPP for which it is responsible as set forth in Appendices A-1, and A-2, and SDG&E shall commence construction of Network Upgrades to its non-JPP facilities for which it is responsible as set forth in Appendix A-3, as soon as practicable after the following additional conditions are satisfied:

- 5.6.1 Approval of the appropriate Governmental Authority has been obtained for any facilities requiring regulatory approval;
 - 5.6.2 Necessary real property rights and rights-of-way have been obtained, to the extent required for the construction of a discrete aspect of Transmission ~~Provider's~~ Owners' Interconnection Facilities and Network Upgrades set forth in Appendices A-1, A-2, and A-3;
 - 5.6.3 Transmission ~~Provider has~~ Owners have received written authorization to proceed with construction from Interconnection Customer by the date specified in ~~Appendix B,~~ Appendices B-1, B-2, and B-3 Milestones; and
 - 5.6.4 Interconnection Customer has provided payment and security ~~to Transmission Provider~~ in accordance with Article 11.5 by the dates specified in ~~Appendix B,~~ Appendices B-1, B-2, and B-3, Milestones.
- 5.6.5 For Phase B of the Interconnection Project only, the conditions specified in Appendix C also shall be met before construction of Transmission Owners' Interconnection Facilities and Network Upgrades commences for that Project Phase.

5.7 Work Progress. The Parties will keep each other advised periodically as to the progress of their respective design, procurement and construction efforts. ~~Either~~ Any Party may, at any time, request a progress report from ~~the other~~ another Party. If, at any time, Interconnection Customer determines that the completion of Transmission ~~Provider's~~ Owners' Interconnection Facilities will not be required until after the specified In-Service Date, Interconnection Customer will provide written notice to ~~Transmission Provider~~ APS, SDG&E, IID, and the CAISO of such later date upon which the completion of Transmission ~~Provider's~~ Owners' Interconnection Facilities will be required.

5.8 Information Exchange. As soon as reasonably practicable after the Effective Date, ~~the Parties~~ Transmission Owners, CAISO and the Interconnection Customer shall exchange information regarding the design and compatibility of the Parties' ~~Interconnection Facilities and compatibility of the Interconnection Facilities with Transmission Provider~~ Owners' and the CAISO's Transmission ~~System~~ Systems, and shall work diligently and in good faith to make any necessary design changes.

- 5.9 Limited Operation.** If any of Transmission ~~Provider's~~Owners' Interconnection Facilities or Network Upgrades are not reasonably expected to be completed prior to the Commercial Operation Date of ~~the Large Generating Facility~~a Project Phase, Transmission ~~Provider~~Owners and CAISO shall, upon the request and at the expense of Interconnection Customer, perform operating studies on a timely basis to determine the extent to which the Large Generating Facility and Interconnection Customer's Interconnection Facilities may operate prior to the completion of Transmission ~~Provider's~~Owners' Interconnection Facilities or Network Upgrades consistent with Applicable Laws and Regulations, Applicable Reliability Standards, Good Utility Practice, and this LGIA Agreement. Transmission ~~Provider~~Owners and CAISO shall permit Interconnection Customer to operate the ~~Large Generating Facility~~Project Phase and Interconnection Customer's Interconnection Facilities in accordance with the results of such studies.
- 5.10 Interconnection Customer's Interconnection Facilities ('ICIF').** Interconnection Customer shall, at its expense, design, procure, construct, own and install the ICIF, as set forth in ~~Appendix A, Interconnection Facilities, Network Upgrades and Distribution Upgrades~~Appendices A-1 and A-2.
- 5.10.1 Interconnection Customer's Interconnection Facility Specifications.** Interconnection Customer shall submit initial specifications for the ICIF and a Project Phase, including System Protection Facilities, to (i) APS, on behalf of Transmission Provider, and (ii) CAISO at least one hundred eighty (180) Calendar Days prior to the Initial Synchronization Date for the Project Phase; and final specifications for review and comment at least ninety (90) Calendar Days prior to the Initial Synchronization Date for the Project Phase. Transmission ~~Provider~~Owners and CAISO shall review such specifications to ensure that the ICIF and Project Phase of Large Generating Facility are compatible with the technical specifications, operational control, and safety requirements of Transmission ~~Provider~~Owners and CAISO and comment on such specifications within thirty (30) Calendar Days of Interconnection Customer's submission. All specifications provided hereunder shall be deemed confidential.
- 5.10.2 Review by Transmission ~~Provider's~~Review Owners and CAISO.** Transmission ~~Provider's~~Owners and CAISO review of Interconnection Customer's final specifications shall not be construed as confirming, endorsing, or providing a warranty as to the design, fitness, safety, durability or reliability of the Large Generating Facility, or the ICIF. Interconnection Customer shall make such changes to the ICIF as may reasonably be required by Transmission ~~Provider~~Owners or CAISO, in accordance with Good Utility Practice, to ensure that the ICIF are compatible with the technical specifications, operational control, and safety requirements of Transmission ~~Provider~~Owners and CAISO.
- 5.10.3 ICIF Construction.** The ICIF shall be designed and constructed in accordance with Good Utility Practice. Within one hundred twenty (120) Calendar Days after the Commercial Operation Date of a Project Phase, unless the Parties agree on another mutually acceptable deadline, Interconnection Customer shall deliver to (i) APS, on behalf of Transmission Provider, and (ii) CAISO "as-

built" drawings, information and documents for the ICIF and the applicable Project Phase of the Large Generating Facility, such as: a one-line diagram, a site plan showing the Large Generating Facility and the ICIF, plan and elevation drawings showing the layout of the ICIF, a relay functional diagram, relaying AC and DC schematic wiring diagrams and relay settings for all facilities associated with Interconnection Customer's step-up transformers, the facilities connecting the ~~Large Generating Facility Project Phase~~ to the step-up transformers and the ICIF, and the impedances (determined by factory tests) for the associated step-up transformers and the ~~Large Generating Facility Project Phase~~. The Interconnection Customer shall provide (i) APS, on behalf of Transmission Provider Owners, and (ii) CAISO specifications for the excitation system, automatic voltage regulator, Large Generating Facility control and protection settings, transformer tap settings, and communications, if applicable. Any deviations from the relay settings, machine specifications, and other specifications originally submitted by the Interconnection Customer shall be assessed by the Transmission Owners and the CAISO pursuant to the appropriate provisions of this Agreement and the APS and CAISO Large Generator Interconnection Procedures.

5.11 Transmission ~~Provider's~~ Owners' Interconnection Facilities Construction.

Transmission ~~Provider's~~ Owners' Interconnection Facilities shall be designed and constructed in accordance with Good Utility Practice. Upon request, within one hundred twenty (120) Calendar Days after the Commercial Operation Date, unless the Parties agree on another mutually acceptable deadline, APS, on behalf of Transmission Provider Owners, shall deliver to Interconnection Customer and the following "CAISO the "as-built" drawings, information and documents for Transmission Provider's Owners' Interconnection Facilities ~~include, including~~ appropriate drawings and relay diagrams}.

APS, on behalf of Transmission Provider Owners, will obtain control of Transmission ~~Provider's~~ Owners' Interconnection Facilities and Stand Alone Network Upgrades to the JPP upon completion of such facilities.

5.12 Access Rights. Upon reasonable notice and supervision by a Party, and subject to any required or necessary regulatory approvals, a Party ("Granting Party") shall furnish at no cost to the other Party ("Access Party") any rights of use, licenses, rights of way and easements with respect to lands owned or controlled by the Granting Party, its agents (if allowed under the applicable agency agreement), or any Affiliate, that are necessary to enable the Access Party to obtain ingress and egress to construct, operate, maintain, repair, test (or witness testing), inspect, replace or remove facilities and equipment to: (i) interconnect the Large Generating Facility with the ~~Transmission System JPP~~; (ii) operate and maintain the Large Generating Facility, the Interconnection Facilities and the ~~Transmission System JPP~~; and (iii) disconnect or remove the Access Party's facilities and equipment upon termination of this LGIA Agreement. In exercising such licenses, rights of way and easements, the Access Party shall not unreasonably disrupt or interfere with normal operation of the Granting Party's business and shall adhere to the safety rules and procedures established in advance, as may be changed from time to time, by the Granting Party and provided to the Access Party.

- 5.13 Lands of Other Property Owners.** If any part of Transmission ~~Provider or Transmission Owner's Owners'~~ Interconnection Facilities and/or Network Upgrades is to be installed on property owned by persons other than Interconnection Customer or Transmission ~~Provider or Transmission Owner~~ Owners, Transmission ~~Provider or Transmission Owner~~ Owners shall at Interconnection Customer's expense use efforts, similar in nature and extent to those that ~~it~~they typically ~~undertakes~~undertake on ~~its~~their own behalf or on behalf of ~~its~~their Affiliates, including use of ~~its~~ eminent domain authority, and to the extent consistent with state law, to procure from such persons any rights of use, licenses, rights of way and easements that are necessary to construct, operate, maintain, test, inspect, replace or remove Transmission ~~Provider or Transmission Owner's Owners'~~ Interconnection Facilities and/or Network Upgrades upon such property.
- 5.14 Permits.** Transmission ~~Provider or Transmission Owner~~ Owners and Interconnection Customer shall cooperate with each other in good faith in obtaining all permits, licenses, and authorizations that are necessary to accomplish the interconnection in compliance with Applicable Laws and Regulations. With respect to this paragraph, Transmission ~~Provider or Transmission Owner~~ Owners shall provide permitting assistance to Interconnection Customer comparable to that provided to Transmission ~~Provider's Owners'~~ own, or an Affiliate's generation.
- 5.15 Early Construction of Base Case Facilities.** Interconnection Customer may request Transmission ~~Provider~~ Owners to construct, and Transmission ~~Provider~~ Owners shall construct, using Reasonable Efforts to accommodate Interconnection Customer's In-Service Date, all or any portion of any Network Upgrades required for Interconnection Customer to be interconnected to the ~~Transmission System~~JPP which are included in the Base Case of the Interconnection Facilities Study for Interconnection Customer, and which also are required to be constructed for another ~~Interconnection Customer~~interconnection customer, but where such construction is not scheduled to be completed in time to achieve Interconnection Customer's In-Service Date.
- 5.16 Suspension.** Interconnection Customer reserves the right, upon written notice to ~~Transmission Provider~~APS, SDG&E, IID and the CAISO, to suspend at any time all work by ~~Transmission Provider~~APS and SDG&E associated with the construction and installation of Transmission ~~Provider's Owners'~~ Interconnection Facilities and/or Network Upgrades required under this LGIA Agreement, other than Network Upgrades, if any, identified in the Phase II Interconnection Study under the CAISO's Large Generator Interconnection Procedures as common to multiple Generating Facilities, with the condition that the Transmission System shall be left in a safe and reliable condition in accordance with Good Utility Practice and Transmission ~~Provider's Owners'~~ safety and reliability criteria, and the Applicable Reliability Standards. In such event, Interconnection Customer shall be responsible for all reasonable and necessary costs which Transmission ~~Provider~~ Owners, (i) ~~has~~have incurred pursuant to this LGIA Agreement prior to the suspension and (ii) ~~incurs~~incur in suspending such work, including any costs incurred to perform such work as may be necessary to ensure the safety of persons and property and the integrity of the Transmission System during such suspension and, if applicable, any costs incurred in connection with the cancellation or suspension of material, equipment and labor contracts which Transmission

~~Provider~~Owners cannot reasonably avoid; provided, however, that prior to canceling or suspending any such material, equipment or labor contract, Transmission ~~Provider~~Owners shall obtain Interconnection Customer's authorization to do so.

~~Transmission Provider~~APS, on behalf of Transmission Owners, with respect to facilities identified on Appendices A-1 and A-2, and SDG&E with respect to facilities identified on Appendix A-3, shall invoice Interconnection Customer for such costs pursuant to Article 12 and shall use due diligence to minimize ~~its~~such costs. In the event Interconnection Customer suspends work ~~by Transmission Provider~~required under this LGIA Agreement pursuant to this Article 5.16, and has not requested ~~APS, on behalf of Transmission Provider Owners, or SDG&E~~ to recommence the work ~~or has not itself recommenced work~~ required under this LGIA ~~on or before the expiration of three (3) years following commencement of such suspension, this LGIA Agreement in time to ensure that Commercial Operation of the full Generating Facility Capacity of the Large Generating Facility is no more than three (3) years from the final Commercial Operation Date identified in Appendices B-1, B-2, and B-3, this Agreement~~ shall be deemed terminated. ~~The three year period and the Interconnection Customer's responsibility for costs of the Transmission Owners' Interconnection Facilities and Network Upgrades set forth in Appendices A-1, A-2, and A-3 will be determined in accordance with Article 2.4. The suspension~~ shall begin on the date the suspension is requested, or the date of the written notice to ~~APS, on behalf of~~ Transmission ~~Provider~~Owners, for its work or SDG&E for its work, if no effective date is specified ~~other than Network Upgrades, if any, identified in the Phase II Interconnection Study under the CAISO's Large Generator Interconnection Procedures.~~

5.17 Taxes.

- 5.17.1 Interconnection Customer Payments Not Taxable.** The Parties intend that all payments or property transfers made by Interconnection Customer to Transmission ~~Provider~~Owners for the installation of Transmission ~~Provider's~~Owners' Interconnection Facilities and the Network Upgrades shall be non-taxable, either as contributions to capital, or as ~~an~~a refundable advance, in accordance with the Internal Revenue Code and any applicable state income tax laws and shall not be taxable as contributions in aid of construction or otherwise under the Internal Revenue Code and any applicable state income tax laws.
- 5.17.2 Representations and Covenants.** In accordance with IRS Notice 2001-82 and IRS Notice 88-129, Interconnection Customer represents and covenants that (i) ownership of the electricity generated at the Large Generating Facility will pass to another party prior to the transmission of the electricity on ~~the~~a Transmission System, (ii) for income tax purposes, the amount of any payments and the cost of any property transferred to Transmission ~~Provider~~Owners for Transmission ~~Provider's~~Owners' Interconnection Facilities will be capitalized by Interconnection Customer as an intangible asset and recovered using the straight-line method over a useful life of twenty (20) years, and (iii) any portion of Transmission ~~Provider's~~Owners' Interconnection Facilities that is a "dual-use intertie," within the meaning of IRS Notice 88-129, is reasonably expected to carry only a de minimis amount of electricity in the direction of the Large

Generating Facility. For this purpose, “de minimis amount” means no more than 5 percent of the total power flows in both directions, calculated in accordance with the “5 percent test” set forth in IRS Notice 88-129. This is not intended to be an exclusive list of the relevant conditions that must be met to conform to IRS requirements for non-taxable treatment.

At a Transmission ProviderOwner’s request, Interconnection Customer shall provide such Transmission ProviderOwner with a report from an independent engineer confirming its representation in clause (iii), above. Transmission ProviderOwners represents and covenants covenant that the cost of Transmission Provider's Owners’ Interconnection Facilities paid for by Interconnection Customer will have no net effect on the base upon which rates are determined.

5.17.3 Indemnification for the Cost Consequences of Current Tax Liability Imposed Upon the Transmission ProviderOwner. Notwithstanding Article 5.17.1, Interconnection Customer shall protect, indemnify and hold harmless each Transmission ProviderOwner from the cost consequences of any current tax liability imposed against a Transmission ProviderOwner as the result of payments or property transfers made by Interconnection Customer to a Transmission ProviderOwner under this LGIA Agreement for Interconnection Facilities, as well as any interest and penalties, other than interest and penalties attributable to any delay caused by a Transmission ProviderOwner.

Transmission ProviderOwner shall not include a gross-up for the cost consequences of any current tax liability in the amounts it charges Interconnection Customer under this LGIA Agreement unless (i) Transmission ProviderOwner has determined, in good faith, that the payments or property transfers made by Interconnection Customer to Transmission ProviderOwner should be reported as income subject to taxation or (ii) any Governmental Authority directs Transmission ProviderOwner to report payments or property as income subject to taxation; provided, however, that Transmission ProviderOwner may require Interconnection Customer to provide security for Interconnection Facilities, in a form reasonably acceptable to Transmission Provider (such as a parental guarantee or a letter of credit) Owner, in an amount equal to the cost consequences of any current tax liability under this Article 5.17. Interconnection Customer shall reimburse Transmission ProviderOwner for such costs on a fully grossed-up basis, in accordance with Article 5.17.4, within thirty (30) Calendar Days of receiving written notification from Transmission ProviderOwner of the amount due, including detail about how the amount was calculated.

The indemnification obligation shall terminate at the earlier of (1) the expiration of the ten year testing period and the applicable statute of limitation, as it may be extended by Transmission ProviderOwner upon request of the IRS, to keep these years open for audit or adjustment, or (2) the occurrence of a subsequent taxable event and the payment of any related indemnification obligations as contemplated by this Article 5.17.

5.17.4 Tax Gross-Up Amount. Interconnection Customer's liability for the cost consequences of any current tax liability under this Article 5.17 shall be calculated on a fully grossed-up basis. Except as may otherwise be agreed to by the parties, this means that Interconnection Customer will pay Transmission ~~Provider~~Owner, in addition to the amount paid for the Interconnection Facilities and Network Upgrades, an amount equal to (1) the current taxes imposed on Transmission ~~Provider~~Owner ("Current Taxes") on the excess of (a) the gross income realized by Transmission ~~Provider~~Owner as a result of payments or property transfers made by Interconnection Customer to Transmission ~~Provider~~Owner under this LGIA Agreement (without regard to any payments under this Article 5.17) (the "Gross Income Amount") over (b) the present value of future tax deductions for depreciation that will be available as a result of such payments or property transfers (the "Present Value Depreciation Amount"), plus (2) an additional amount sufficient to permit Transmission ~~Provider~~Owner to receive and retain, after the payment of all Current Taxes, an amount equal to the net amount described in clause (1).

For this purpose, (i) Current Taxes shall be computed based on Transmission ~~Provider~~Owner's composite federal and state tax rates at the time the payments or property transfers are received and Transmission ~~Provider~~Owner will be treated as being subject to tax at the highest marginal rates in effect at that time (the "Current Tax Rate"), and (ii) the Present Value Depreciation Amount shall be computed by discounting Transmission ~~Provider~~Owner's anticipated tax depreciation deductions as a result of such payments or property transfers by Transmission ~~Provider~~Owner's current weighted average cost of capital. Thus, the formula for calculating Interconnection Customer's liability to each respective Transmission Owner pursuant to this Article 5.17.4 can be expressed as follows: $(\text{Current Tax Rate} \times (\text{Gross Income Amount} - \text{Present Value of Tax Depreciation})) / (1 - \text{Current Tax Rate})$. Interconnection Customer's estimated tax liability in the event taxes are imposed shall be stated in ~~Appendix A, Interconnection Facilities, Network Upgrades and Distribution Upgrades~~ Appendices A-1, A-2, and A-3.

5.17.5 Private Letter Ruling or Change or Clarification of Law. At Interconnection Customer's request and expense, Transmission ~~Provider~~Owner shall file with the IRS a request for a private letter ruling as to whether any property transferred or sums paid, or to be paid, by Interconnection Customer to Transmission ~~Provider~~Owner under this LGIA Agreement are subject to federal income taxation. Interconnection Customer will prepare the initial draft of the request for a private letter ruling, and will certify under penalties of perjury that all facts represented in such request are true and accurate to the best of Interconnection Customer's knowledge. Transmission ~~Provider~~Owner and Interconnection Customer shall cooperate in good faith with respect to the submission of such request.

Transmission ~~Provider~~Owner shall keep Interconnection Customer fully informed of the status of such request for a private letter ruling and shall execute either a privacy act waiver or a limited power of attorney, in a form acceptable to

the IRS, that authorizes Interconnection Customer to participate in all discussions with the IRS regarding such request for a private letter ruling. Transmission ~~Provider~~Owner shall allow Interconnection Customer to attend all meetings with IRS officials about the request and shall permit Interconnection Customer to prepare the initial drafts of any follow-up letters in connection with the request.

5.17.6 Subsequent Taxable Events. If, within 10 years from the date on which the relevant Transmission ~~Provider~~Owner's Interconnection Facilities are placed in service, (i) Interconnection Customer Breaches the covenants contained in Article 5.17.2, (ii) a "disqualification event" occurs within the meaning of IRS Notice 88-129, or (iii) this LGIA Agreement terminates and Transmission ~~Provider~~Owner retains ownership of the Interconnection Facilities and Network Upgrades, Interconnection Customer shall pay a tax gross-up for the cost consequences of any current tax liability imposed on Transmission ~~Provider~~Owner, calculated using the methodology described in Article 5.17.4 and in accordance with IRS Notice 90-60.

5.17.7 Contests. In the event any Governmental Authority determines that a Transmission ~~Provider~~Owner's receipt of payments or property constitutes income that is subject to taxation, such Transmission ~~Provider~~Owner shall notify Interconnection Customer, in writing, within thirty (30) Calendar Days of receiving notification of such determination by a Governmental Authority. Upon the timely written request by Interconnection Customer and at Interconnection Customer's sole expense, such Transmission ~~Provider~~Owner may appeal, protest, seek abatement of, or otherwise oppose such determination. Upon Interconnection Customer's written request and sole expense, such Transmission ~~Provider~~Owner may file a claim for refund with respect to any taxes paid under this Article 5.17, whether or not it has received such a determination. Such Transmission ~~Provider~~Owner reserves the right to make all decisions with regard to the prosecution of such appeal, protest, abatement or other contest, including the selection of counsel and compromise or settlement of the claim, but such Transmission ~~Provider~~Owner shall keep Interconnection Customer informed, shall consider in good faith suggestions from Interconnection Customer about the conduct of the contest, and shall reasonably permit Interconnection Customer or an Interconnection Customer representative to attend contest proceedings.

Interconnection Customer shall pay to such Transmission ~~Provider~~Owner on a periodic basis, as invoiced by Transmission ~~Provider~~Owner, Transmission ~~Provider~~Owner's documented reasonable costs of prosecuting such appeal, protest, abatement or other contest. At any time during the contest, such Transmission ~~Provider~~Owner may agree to a settlement either with Interconnection Customer's consent or after obtaining written advice from nationally-recognized tax counsel, selected by such Transmission ~~Provider~~Owner, but reasonably acceptable to Interconnection Customer, that the proposed settlement represents a reasonable settlement given the hazards of litigation. Interconnection Customer's obligation shall be based on the amount of the settlement agreed to by Interconnection Customer, or if a higher amount, so much of the settlement that is supported by the written advice from nationally-

recognized tax counsel selected under the terms of the preceding sentence. The settlement amount shall be calculated on a fully grossed-up basis to cover any related cost consequences of the current tax liability. Any settlement without Interconnection Customer's consent or such written advice will relieve Interconnection Customer from any obligation to indemnify such Transmission ~~Provider~~Owner for the tax at issue in the contest.

5.17.8 Refund. In the event that (a) a private letter ruling is issued to a Transmission ~~Provider~~Owner which holds that any amount paid or the value of any property transferred by Interconnection Customer to such Transmission ~~Provider~~Owner under the terms of this LGIA Agreement is not subject to federal income taxation, (b) any legislative change or administrative announcement, notice, ruling or other determination makes it reasonably clear to such Transmission ~~Provider~~Owner in good faith that any amount paid or the value of any property transferred by Interconnection Customer to such Transmission ~~Provider~~Owner under the terms of this LGIA Agreement is not taxable to such Transmission ~~Provider~~Owner, (c) any abatement, appeal, protest, or other contest results in a determination that any payments or transfers made by Interconnection Customer to such Transmission ~~Provider~~Owner are not subject to federal income tax, or (d) if such Transmission ~~Provider~~Owner receives a refund from any taxing authority for any overpayment of tax attributable to any payment or property transfer made by Interconnection Customer to such Transmission ~~Provider~~Owner pursuant to this LGIA Agreement, such Transmission ~~Provider~~Owner shall promptly refund to Interconnection Customer the following:

(i) any payment made by Interconnection Customer under this Article 5.17 to such Transmission Owner for taxes that is attributable to the amount determined to be non-taxable, together with interest thereon,

(ii) interest on any amount paid by Interconnection Customer to such Transmission ~~Provider~~Owner for such taxes which Transmission ~~Provider~~Owner did not submit to the taxing authority, calculated in accordance with the methodology set forth in FERC's regulations at 18 CFR §35.19a(a)(2)(iii) from the date payment was made by Interconnection Customer to the date such Transmission ~~Provider~~Owner refunds such payment to Interconnection Customer, and

(iii) with respect to any such taxes paid by such Transmission ~~Provider~~Owner, any refund or credit such Transmission ~~Provider~~Owner receives or to which it may be entitled from any Governmental Authority, interest (or that portion thereof attributable to the payment described in clause (i), above) owed to such Transmission ~~Provider~~Owner for such overpayment of taxes (including any reduction in interest otherwise payable by such Transmission ~~Provider~~Owner to any Governmental Authority resulting from an offset or credit); provided, however, that such Transmission ~~Provider~~Owner will remit such amount promptly to Interconnection Customer only after and to the extent that such Transmission ~~Provider~~Owner has received a tax refund,

credit or offset from any Governmental Authority for any applicable overpayment of income tax related to such Transmission ~~Provider~~Owner's Interconnection Facilities.

The intent of this provision is to leave the Parties, to the extent practicable, in the event that no taxes are due with respect to any payment for Transmission Owners' Interconnection Facilities and Network Upgrades hereunder, in the same position they would have been in had no such tax payments been made.

5.17.9 Taxes Other Than Income Taxes. Upon the timely request by Interconnection Customer, and at Interconnection Customer's sole expense, Transmission ~~Provider~~Owner or the CAISO may appeal, protest, seek abatement of, or otherwise contest any tax (other than federal or state income tax) asserted or assessed against Transmission ~~Provider~~Owner or the CAISO for which Interconnection Customer may be required to reimburse Transmission ~~Provider~~Owner or the CAISO under the terms of this LGIA Agreement. Interconnection Customer shall pay to Transmission ~~Provider~~Owner on a periodic basis, as invoiced by Transmission ~~Provider~~Owner, Transmission ~~Provider's~~Owners' documented reasonable costs of prosecuting such appeal, protest, abatement, or other contest. Interconnection Customer ~~and~~, Transmission ~~Provider~~Owner and the CAISO if applicable, shall cooperate in good faith with respect to any such contest. Unless the payment of such taxes is a prerequisite to an appeal or abatement or cannot be deferred, no amount shall be payable by Interconnection Customer to Transmission ~~Provider~~Owner or the CAISO for such taxes until they are assessed by a final, non-appealable order by any court or agency of competent jurisdiction. In the event that a tax payment is withheld and ultimately due and payable after appeal, Interconnection Customer will be responsible for all taxes, interest and penalties, other than penalties attributable to any delay caused by Transmission ~~Provider~~Owner or the CAISO.

~~5.17.10 Transmission Owners Who Are Not Transmission Providers. If Transmission Provider is not the same entity as the Transmission Owner, then (i) all references in this Article 5.17 to Transmission Provider shall be deemed also to refer to and to include the Transmission Owner, as appropriate, and (ii) this LGIA shall not become effective until such Transmission Owner shall have agreed in writing to assume all of the duties and obligations of Transmission Provider under this Article 5.17 of this LGIA.~~

5.18 Tax Status. Each Party shall cooperate with the ~~other~~others to maintain the other ~~Party's~~Parties' tax status. Nothing in this LGIA Agreement is intended to adversely affect any Transmission ~~Provider~~Owner's or the CAISO's tax exempt status with respect to the issuance of bonds including, but not limited to, Local Furnishing Bonds.

5.19 Modification.

5.19.1 General. ~~Either Party~~The Interconnection Customer or the Transmission Owners may undertake modifications to ~~its~~their facilities. ~~If a Party plans~~their respective facilities, subject to the provisions of this Agreement and any

applicable provisions of any applicable Tariff. If either the Interconnection Customer on the one hand, or Transmission Owners on the other hand, plan to undertake a modification that reasonably may be expected to affect the other Party's facilities, that the Party planning the modification shall provide to the other PartyParties sufficient information regarding such modification so that the other PartyParties may evaluate the potential impact of such modification prior to commencement of the work or implementation of the modification. Such information shall be deemed to be confidential hereunder and shall include information concerning the timing of such modifications and whether such modifications are expected to interrupt the flow of electricity from the Large Generating Facility. The Party desiring to perform such work or implement the modification shall provide the relevant drawings, plans, and specifications to the other PartyParties at least ninety (90) Calendar Days in advance of the commencement of the work or implementation of the modification or such shorter period upon which the Parties may agree, which agreement shall not unreasonably be withheld, conditioned or delayed.

In the case of Large Generating Facility modifications that do not require Interconnection Customer to submit an Interconnection Request, Transmission ProviderOwners and the CAISO shall provide, within thirty (30) Calendar Days (or such other time as the Parties may agree), an estimate of any additional modifications to the Transmission SystemSystems, Transmission Provider'sOwners' Interconnection Facilities or Network Upgrades necessitated by such Interconnection Customer modification and a good faith estimate of the costs thereof. The Transmission Owners and the CAISO shall each determine if a Large Generating Facility modification is a Material Modification in accordance with their respective Large Generator Interconnection Procedures.

Notwithstanding anything in this Agreement to the contrary, any modification to the Large Generating Facility or the terms upon which Interconnection Service is provided hereunder that requires additional facilities beyond or in lieu of those facilities specifically identified in Appendices A-1, A-2, and A-3, including but not limited to additional Transmission Owners' Interconnection Facilities or Network Upgrades, shall be dealt with in a separate Large Generator Interconnection Agreement or in an amendment to this Agreement agreed to by all Parties; provided, however, that to the extent IID determines the modification requires additional non-JPP facilities owned by IID, such change may be dealt with in a separate Affected System Study Agreement and/or Affected System Construction and Operation Agreement.

- 5.19.2 Standards.** Any additions, modifications, or replacements made to a Party's facilities the Transmission Systems or Transmission Owners' Interconnection Facilities that may reasonably be expected to affect the Generating Facility or Interconnection Facilities shall be designed, constructed and operated in accordance with this Agreement, Applicable Reliability Standards, and Good Utility Practice. Any additions, modifications, or replacements made to the Generating Facility or Interconnection Customer's Interconnection Facilities that may reasonably be expected to affect the Transmission Systems or Transmission

Owners' Interconnection Facilities shall be designed, constructed and operated in accordance with this LGIA Agreement, Applicable Reliability Standards, and Good Utility Practice.

5.19.3 Modification Costs. Interconnection Customer shall not be directly assigned for the costs of any additions, modifications, or replacements that Transmission ~~Provider makes~~ Owners make to Transmission ~~Provider's~~ Owners' Interconnection Facilities or ~~the~~ to each respective Transmission Owner's Transmission System to facilitate the interconnection of a third party to Transmission ~~Provider's~~ Owners' Interconnection Facilities or the applicable Transmission Owner's Transmission System, or to provide transmission service to a third party under ~~Transmission Provider's~~ the applicable Tariff, *i.e.*, APS, IID and the CAISO. Interconnection Customer shall be responsible for the costs of any additions, modifications, or replacements to ~~Interconnection Customer's~~ Interconnection Facilities that may be necessary to maintain or upgrade such ~~Interconnection Customer's~~ Interconnection Facilities consistent with Applicable Laws and Regulations, Applicable Reliability Standards or Good Utility Practice.

Article 6. Testing and Inspection

6.1 Pre-Commercial Operation Date Testing and Modifications. Prior to the Commercial Operation Date, APS, on behalf of Transmission ~~Provider~~ Owners, shall test Transmission ~~Provider's~~ Owners' Interconnection Facilities and Network Upgrades to the JPP in Appendices A-1 and A-2, and SDG&E shall test Network Upgrades to its non-JPP facilities in Appendix A-3. To the extent that the Affected System Study performed by IID identifies the need to install or construct any Network Upgrades to non-JPP facilities owned by IID, then IID shall test such Network Upgrades to non-JPP facilities prior to the Commercial Operation Date and Interconnection Customer shall test the Large Generating Facility and Interconnection Customer's Interconnection Facilities to ensure their safe and reliable operation. Similar testing may be required after initial operation. ~~Each Party~~ APS, on behalf of Transmission Owners, SDG&E, IID, and the Interconnection Customer shall make any modifications to ~~its~~ their respective facilities that are found to be necessary as a result of such testing. The Interconnection Customer shall bear the cost of all such testing and modifications. The Interconnection Customer shall not commence initial parallel operation of the first Project Block for Phase A of the Generating Facility or the first Project Block of Phase B of the Generating Facility with the Transmission System until the Transmission Owners provide prior written approval, which shall not be unreasonably withheld, for operation of such Project Phase. Interconnection Customer shall generate test energy at the Large Generating Facility only if it has arranged for the delivery of such test energy.

6.2 Post-Commercial Operation Date Testing and Modifications. ~~Each~~ As between Transmission Owners for the JPP facilities in Appendices A-1 and A-2, SDG&E for its non-JPP facilities in Appendix A-3, and IID for its non-JPP facilities, if any are identified in the Affected System Study, respectively, and Interconnection Customer, each Party shall at its own expense perform routine inspection and testing of its facilities and equipment in accordance with Good Utility Practice as may be necessary to ensure the continued interconnection of the Large Generating Facility with the ~~Transmission~~

~~System~~JPP in a safe and reliable manner. ~~Each~~As between Transmission Owners for the JPP facilities in Appendices A-1 and A-2, SDG&E for its non-JPP facilities in Appendix A-3, and IID for its non-JPP facilities, if any are identified in the Affected System Study, respectively, and Interconnection Customer, each Party shall have the right, upon advance written notice, to require reasonable additional testing of the other Party's facilities, at the requesting Party's expense, as may be in accordance with Good Utility Practice.

- 6.3 Right to Observe Testing.** Each Party shall notify the other ~~Party~~Parties at least fourteen (14) Calendar Days in advance of its performance of tests of its Interconnection Facilities or Generating Facility. The other ~~Party has~~Parties have the right, at ~~its~~their own expense, to observe such testing.
- 6.4 Right to Inspect.** Each Party shall have the right, but shall have no obligation to: (i) observe ~~the other~~another Party's tests and/or inspection of any of its System Protection Facilities and other protective equipment, including Power System Stabilizers; (ii) review the settings of ~~the other~~another Party's System Protection Facilities and other protective equipment; and (iii) review ~~the other~~another Party's maintenance records relative to the Interconnection Facilities, the System Protection Facilities and other protective equipment. A Party may exercise these rights from time to time as it deems necessary upon reasonable notice to the other Party. The exercise or non-exercise by a Party of any such rights shall not be construed as an endorsement or confirmation of any element or condition of the Interconnection Facilities or the System Protection Facilities or other protective equipment or the operation thereof, or as a warranty as to the fitness, safety, desirability, or reliability of same. Any information that a Party obtains through the exercise of any of its rights under this Article 6.4 shall be deemed to be Confidential Information and treated pursuant to Article 22 of this LGIA Agreement.

Article 7. Metering

- 7.1 General.** Each Party shall comply with any Applicable Reliability Standards and the Applicable Reliability Council requirements. Unless otherwise agreed by the Parties, APS, on behalf of Transmission ~~Provider~~Owners, shall install Metering Equipment at the Point of Interconnection prior to any operation of the Large Generating Facility and shall own, operate, test and maintain such Metering Equipment. Power flows to and from the Large Generating Facility shall be measured at or, at Transmission ~~Provider's~~Owners' option, compensated to, the Point of Interconnection. APS, on behalf of Transmission ~~Provider~~Owners, shall provide metering quantities, in analog and/or digital form, to Interconnection Customer upon request. Interconnection Customer shall bear all reasonable documented costs associated with the purchase, installation, operation, testing and maintenance of the Metering Equipment.
- 7.2 Check Meters.** Interconnection Customer, at its option and expense, may install and operate, on its premises and on its side of the Point of Interconnection, one or more check meters to check Transmission ~~Provider's~~Owners' meters. Such check meters shall be for check purposes only and shall not be used for the measurement of power flows for purposes of this LGIA Agreement, except as provided in Article 7.4 below. The check meters shall be subject at all reasonable times to inspection and examination by APS, on

behalf of Transmission ~~Provider~~Owners, or its designee. The installation, operation and maintenance thereof shall be performed entirely by Interconnection Customer in accordance with Good Utility Practice.

7.3 Standards. APS, on behalf of Transmission ~~Provider~~Owners, shall install, calibrate, and test revenue quality Metering Equipment in accordance with applicable ANSI standards.

7.4 Testing of Metering Equipment. APS, on behalf of Transmission ~~Provider~~Owners, shall inspect and test all Transmission ~~Provider-owned~~Owner Metering Equipment for the JPP upon installation and at least once every two (2) years thereafter. If requested to do so by Interconnection Customer, APS, on behalf of Transmission ~~Provider~~Owners, shall, at Interconnection Customer's expense, inspect or test such Metering Equipment more frequently than every two (2) years. APS, on behalf of Transmission ~~Provider~~Owners, shall give reasonable notice of the time when any inspection or test shall take place, and Interconnection Customer may have representatives present at the test or inspection. If at any time Metering Equipment is found to be inaccurate or defective, it shall be adjusted, repaired or replaced at Interconnection Customer's expense, in order to provide accurate metering, unless the inaccuracy or defect is due to Transmission ~~Provider's~~Owners' failure to maintain, then Transmission ~~Provider~~Owners shall pay. If Metering Equipment fails to register, or if the measurement made by Metering Equipment during a test varies by more than two percent from the measurement made by the standard meter used in the test, APS, on behalf of Transmission ~~Provider~~Owners, shall adjust the measurements by correcting all measurements for the period during which Metering Equipment was in error by using Interconnection Customer's check meters, if installed. If no such check meters are installed or if the period cannot be reasonably ascertained, the adjustment shall be for the period immediately preceding the test of the Metering Equipment equal to one-half the time from the date of the last previous test of the Metering Equipment.

7.5 Metering Data. At Interconnection Customer's expense, the metered data shall be telemetered to one or more locations designated by Transmission ~~Provider~~Owners and one or more locations designated by Interconnection Customer. ~~Such~~Subject to Article 7.6, such telemetered data shall be used, under normal operating conditions, as the official measurement of the amount of energy delivered from the Large Generating Facility to the Point of Interconnection.

7.6 Metering Requirements of CAISO. Notwithstanding the other provisions of Article 7, if the Interconnection Customer elects the CAISO as the Balancing Authority for a Project Phase, the Interconnection Customer shall also comply with the metering requirements of the CAISO Tariff for such Phase, including installation of Metering Equipment in compliance with the requirements of the CAISO Tariff. For Phase A of the Generating Facility the Interconnection Customer has selected the CAISO as the Balancing Authority, so for Phase A of the Generating Facility, in addition to the requirements of this Article 7, the Interconnection Customer shall also comply with the metering requirements of the CAISO Tariff. If the Interconnection Customer elects the CAISO as the Balancing Authority for Phase B of the Generating Facility pursuant to Article 9.2 of this Agreement, the Interconnection Customer shall also comply with the requirements of this Article 7 and the metering requirements of the CAISO Tariff for

Phase B of the Generating Facility. Notwithstanding the provisions of Article 7.5, for any Project Phase in the CAISO Balancing Authority Area, data from the CAISO-compliant metering shall be used, under normal operating conditions, as the official measurement of the amount of energy delivered from the Large Generating Facility to the Point of Interconnection. Any Metering Equipment installed by APS on behalf of the Transmission Owners will serve as an alternative source for meter data for the CAISO in the event of failure of the CAISO-compliant metering to provide accurate meter data.

Article 8. Communications

- 8.1 Interconnection Customer Obligations.** Interconnection Customer shall maintain satisfactory operating communications with ~~Transmission Provider~~APS's Transmission System dispatcher or representative designated by ~~Transmission Provider~~APS, and with CAISO, to the extent CAISO is selected by Interconnection Customer as Balancing Authority for a Project Phase. Interconnection Customer shall provide standard voice line, dedicated voice line and facsimile communications at its Large Generating Facility control room or central dispatch facility through use of either the public telephone system, or a voice communications system that does not rely on the public telephone system. Interconnection Customer shall also provide the dedicated data circuit(s) necessary to provide Interconnection Customer data to APS, on behalf of ~~Transmission Provider~~Owners as set forth in Appendix D, Security Arrangements Details, and as applicable, to CAISO. The data circuit(s) shall extend from the Large Generating Facility to the location(s) specified by APS, on behalf of ~~Transmission Provider~~Owners, and the CAISO. Any required maintenance of such communications equipment shall be performed by Interconnection Customer. Operational communications shall be activated and maintained under, but not be limited to, the following events: system paralleling or separation, scheduled and unscheduled shutdowns, equipment clearances, and hourly and daily load data.
- 8.2 Remote Terminal Unit.** Prior to the Initial Synchronization Date of ~~the Large Generating Facility~~any Project Phase, a Remote Terminal Unit, or equivalent data collection and transfer equipment acceptable to the Parties, shall be installed by Interconnection Customer, or by APS, on behalf of ~~Transmission Provider~~Owners, at Interconnection Customer's expense, to gather accumulated and instantaneous data to be telemetered to the location(s) designated by APS, on behalf of ~~Transmission Provider~~Owners, through use of a dedicated point-to-point data circuit(s) as indicated in Article 8.1. The communication protocol for the data circuit(s) shall be specified by APS, on behalf of ~~Transmission Provider~~Owners. Instantaneous bi-directional analog real power and reactive power flow information must be telemetered directly to the location(s) specified by APS.

As among APS, on behalf of ~~Transmission Provider~~Each Owners, CAISO and Interconnection Customer, each such Party will promptly advise the other ~~Party~~Parties if it detects or otherwise learns of any metering, telemetry or communications equipment errors or malfunctions that require the attention and/or correction by the other ~~Party~~Parties. The Party owning such equipment shall correct such error or malfunction as soon as reasonably feasible.

8.3 No Annexation. Any and all equipment placed on the premises of a Party shall be and remain the property of the Party providing such equipment regardless of the mode and manner of annexation or attachment to real property, unless otherwise mutually agreed by the Parties.

8.4 Communication Requirements of CAISO. Notwithstanding the other provisions of Article 8, if the Interconnection Customer elects the CAISO as the Balancing Authority for a Project Phase, the Interconnection Customer shall also comply with the communications requirements of the CAISO Tariff. For Phase A of the Generating Facility the Interconnection Customer has selected the CAISO as the Balancing Authority, so for Phase A of the Generating Facility, in addition to the requirements of this Article 8, the Interconnection Customer shall also comply with the communications requirements of the CAISO Tariff. If the Interconnection Customer elects the CAISO as the Balancing Authority for Phase B of the Generating Facility pursuant to Article 9.2 of this Agreement, the Interconnection Customer shall also comply with the requirements of this Article 8 and the communications requirements of the CAISO Tariff for Phase B of the Generating Facility.

Article 9. Operations

9.1 General. Each Party shall comply with Applicable Reliability Standards and the Applicable Reliability Council requirements. Each Party shall provide to the other ~~Party~~Parties all information that may reasonably be required by the other ~~Party~~Parties to comply with Applicable Laws and Regulations and Applicable Reliability Standards.

9.2 ~~Control~~Balancing Authority Area Notification. At least three months before Initial Synchronization Date of a Project Phase, Interconnection Customer shall notify ~~Transmission Provider~~APS and the CAISO in writing of the ~~Control~~Balancing Authority Area in which ~~the Large Generating Facility will be located. If Interconnection Customer elects to locate the Large Generating Facility in a Control Area other than the Control Area in which the Large Generating Facility is physically located, and that Project Phase will be located,~~ if and as permitted ~~to do so~~ by the relevant transmission tariffs, ~~all~~including the APS and CAISO Tariffs. All necessary arrangements, including but not limited to those set forth in ~~Article~~Articles 7 and ~~Article~~8 of this ~~LGIA~~Agreement, and remote ~~Control~~Balancing Authority Area generator interchange agreements, if applicable, and the appropriate measures under such agreements, shall be executed and implemented prior to the placement ~~of the Large Generating Facility in the other Control Area.~~a Project Phase in the designated Balancing Authority Area. Separate notifications will be required for each Project Phase, as specified in Appendix C.

9.3 Transmission ~~Provider~~Owner and CAISO Obligations. The Transmission ~~Provider~~Owners and the CAISO shall cause their respective Transmission Systems and APS, on behalf of Transmission Owners, shall cause the Transmission Owners' Interconnection Facilities to be operated, maintained and controlled in a safe and reliable manner and in accordance with this ~~LGIA. Transmission Provider~~Agreement. ~~APS and the CAISO~~ may provide operating instructions to Interconnection Customer consistent with this ~~LGIA and Transmission Provider~~Agreement and APS's or the CAISO's operating protocols and procedures as

they may change from time to time. ~~Transmission Provider~~ APS and the CAISO will consider changes to ~~its~~ their respective operating protocols and procedures proposed by Interconnection Customer.

- 9.4 Interconnection Customer Obligations.** Interconnection Customer shall at its own expense operate, maintain and control the Large Generating Facility and Interconnection Customer's Interconnection Facilities in a safe and reliable manner and in accordance with this LGIA Agreement. Interconnection Customer shall operate the Large Generating Facility and Interconnection Customer's Interconnection Facilities in accordance with all applicable requirements of the ~~Control~~ Balancing Authority Area of which it is part, as such requirements are set forth in Appendix C, Interconnection Details, of this ~~LGIA Agreement~~. Appendix C, Interconnection Details, will be modified to reflect changes to the requirements as they may change from time to time. ~~Either A~~ Party may request that the other ~~Party Parties~~ provide copies of the requirements set forth in Appendix C, Interconnection Details, of this ~~LGIA Agreement~~.
- 9.5 Start-Up and Synchronization.** Consistent with the Parties' mutually acceptable procedures, Interconnection Customer is responsible for the proper synchronization of the Large Generating Facility to ~~Transmission Provider's Transmission System~~ the JPP.
- 9.6 Reactive Power.**
- 9.6.1 Power Factor Design Criteria.** Interconnection Customer shall design Phase A of the Large Generating Facility to maintain a composite power delivery at continuous rated power output at the Point of Interconnection at a power factor within the range of 0.95 leading to 0.95 lagging, ~~unless Transmission Provider has established different requirements that apply to all generators in the Control Area on a comparable basis. The requirements of this paragraph shall not apply to wind generators which power factor range shall supersede any otherwise applicable power factor range set forth in the CAISO Tariff. The Interconnection Customer shall design Phase B of the Large Generating Facility to maintain a composite power delivery at continuous rated power output at the Point of Interconnection at a power factor within the range of 0.95 leading to 0.95 lagging or the Applicable Reliability Standard in effect at the time the Interconnection Studies for Phase B of the Generating Facility are performed. For Phase B of the Generating Facility, the Interconnection Studies for that Project Phase demonstrate or shall demonstrate that that Project Phase complies with Article 9.6.1 before Phase B of the Interconnection Project commences Trial Operation.~~
- 9.6.2 Voltage Schedules.** ~~Once~~ APS shall be responsible for compliance with Applicable Reliability Standards related to reactive power and voltage schedules for the interconnection of the Large Generating Facility to the JPP, subject to any agreement entered into by APS and the CAISO regarding the allocation of responsibilities for compliance with Applicable Reliability Standards. Pursuant to that responsibility, once Interconnection Customer has synchronized the Large Generating Facility with the ~~Transmission System, Transmission Provider~~ JPP, ~~APS~~ shall require Interconnection Customer to operate the Large Generating Facility to produce or absorb reactive power within the design limitations of the

Large Generating Facility set forth in Article 9.6.1 (Power Factor Design Criteria), ~~Transmission Provider's voltage~~, Appendix C, and the Interconnection Customer's data, as revised, that were provided for the Interconnection Studies, Voltage schedules required by APS shall treat all sources of reactive power ~~in~~ interconnected to the ~~Control Area~~ JPP in an equitable and not unduly discriminatory manner. ~~Transmission Provider~~ APS shall exercise Reasonable Efforts to provide Interconnection Customer with such schedules at least one (1) day in advance, and may make changes to such schedules as necessary to maintain the reliability of the Transmission ~~System~~ Systems. Interconnection Customer shall operate the Large Generating Facility to maintain the specified output voltage or power factor at the Point of Interconnection within the design limitations of the Large Generating Facility set forth in Article 9.6.1 (Power Factor Design Criteria), and the Interconnection Customer's data, as revised, that were provided for the Interconnection Studies. If Interconnection Customer is unable to maintain the specified voltage or power factor, it shall promptly notify the ~~System Operator~~ APS system operator.

9.6.2.1 Governors and Regulators. ~~Whenever~~ To the extent required by Applicable Reliability Standards, the Interconnection Customer shall procure, install, and maintain governors and regulators. To the extent required by Applicable Reliability Standards, whenever the Large Generating Facility is operated in parallel with the Transmission System and the speed governors (if installed on the generating unit pursuant to Good Utility Practice) and voltage regulators are capable of operation, Interconnection Customer shall operate the Large Generating Facility with its speed governors and voltage regulators in automatic operation. If the Large Generating Facility's speed governors and voltage regulators are not capable of such automatic operation, Interconnection Customer shall immediately notify ~~Transmission Provider's system operator, or its designated representative,~~ APS and the CAISO and ensure that such Large Generating Facility's operates as specified in Article 9.6.2 through manual operation and that its reactive power production or absorption (measured in MVARs) are within the design capability of the Large Generating Facility's generating unit(s) and steady state stability limits. The Interconnection Customer shall restore the speed governors and voltage regulators to automatic operation as soon as possible. If the Large Generating Facility's speed governors and voltage regulators are improperly tuned or malfunctioning, APS or the CAISO shall have the right to order the reduction in output or disconnection of the Large Generating Facility if the reliability of the Transmission System would be adversely affected. Interconnection Customer shall not cause its Large Generating Facility to disconnect automatically or instantaneously from the Transmission System or trip any generating unit comprising the Large Generating Facility for an under or over frequency condition unless the abnormal frequency condition persists for a time period beyond the limits set forth in ANSI/IEEE Standard C37.106, or such other standard as applied to other generators ~~in~~ interconnecting to the ~~Control Area~~ JPP on a comparable basis.

9.6.3 Payment for Reactive Power. ~~Transmission Provider~~APS is required to pay Interconnection Customer for reactive power that Interconnection Customer provides or absorbs from the Large Generating Facility when ~~Transmission Provider~~APS requests Interconnection Customer to operate its Large Generating Facility outside the range specified in Article 9.6.1, provided that if ~~Transmission Provider~~APS pays its own or affiliated generators for reactive power service within the specified range, it must also pay Interconnection Customer. Payments shall be pursuant to Article 11.6 or such other agreement to which the Parties have otherwise agreed.

9.7 Outages and Interruptions.

9.7.1 Outages.

9.7.1.1 Outage Authority and Coordination. Each Party may in accordance with Good Utility Practice in coordination with the other ~~Party~~Parties remove from service any of its respective Interconnection Facilities or Network Upgrades that may impact the other ~~Party's~~Parties' facilities as necessary to perform maintenance or testing or to install or replace equipment, provided that the Interconnection Customer shall also coordinate outages of the Generating Facility with the CAISO pursuant to the provisions of the CAISO Tariff for each Project Phase that is within the CAISO Balancing Authority Area, and APS shall coordinate outages of the JPP and Transmission Owner Interconnection Facilities with the CAISO in accordance with agreed procedures. Absent an Emergency Condition, the Party scheduling a removal of such facility(ies) from service will use Reasonable Efforts to schedule such removal on a date and time mutually acceptable to the Parties. In all circumstances, any Party planning to remove such facility(ies) from service shall use Reasonable Efforts to minimize the effect on the other Party of such removal.

9.7.1.2 Outage Schedules. ~~Transmission Provider~~ APS, IID and CAISO shall post scheduled outages of ~~its~~their respective transmission facilities ~~on the OASIS~~in accordance with applicable Tariff requirements. Interconnection Customer shall submit its planned maintenance schedules for the Large Generating Facility to ~~Transmission Provider~~APS for a minimum of a rolling twenty-four month period and to the CAISO in accordance with the CAISO Tariff for any Project Phase in the CAISO Balancing Authority Area. Interconnection Customer shall update its planned maintenance schedules as necessary. ~~Transmission Provider, including providing updates to the CAISO in accordance with the CAISO Tariff. APS, on behalf of Transmission Owners, and the CAISO, in accordance with the applicable provisions of the CAISO Tariff,~~ may request Interconnection Customer to reschedule its maintenance as necessary to maintain the reliability of Transmission Owners' and the CAISO Transmission SystemSystems; provided,

however, adequacy of generation supply shall not be a criterion in determining Transmission System reliability. ~~Transmission Provider,~~ subject to Section 9 of the CAISO Tariff. APS shall compensate Interconnection Customer for any additional direct costs that Interconnection Customer incurs as a result of having to reschedule maintenance, including any additional overtime, breaking of maintenance contracts or other costs above and beyond the cost Interconnection Customer would have incurred absent ~~Transmission Provider~~ APS's request to reschedule maintenance. The CAISO shall compensate Interconnection Customer for any additional direct costs that Interconnection Customer incurs as a result of having to reschedule maintenance in accordance with the CAISO Tariff. Interconnection Customer will not be eligible to receive compensation, if during the twelve (12) months prior to the date of the scheduled maintenance, Interconnection Customer had modified its schedule of maintenance activities.

9.7.1.3 Outage Restoration. If an outage on a Party's Interconnection Facilities or Network Upgrades adversely affects ~~the other~~ another Party's operations or facilities, the Party that owns or controls the facility that is out of service shall use Reasonable Efforts to promptly restore such facility(ies) to a normal operating condition consistent with the nature of the outage. The Party that owns or controls the facility that is out of service shall provide the other ~~Party~~ Parties, to the extent such information is known, information on the nature of the Emergency Condition, if the outage is caused by an Emergency Condition, an estimated time of restoration, and any corrective actions required. Initial verbal notice shall be followed up as soon as practicable with written notice explaining the nature of the outage, if requested by a Party, which may be provided by e-mail or facsimile.

9.7.2 Interruption of Service. If required by Good Utility Practice to do so, APS, on behalf of the Transmission ~~Provider~~ Owners, may require Interconnection Customer to interrupt or reduce deliveries of electricity if such delivery of electricity could adversely affect ~~Transmission Provider's~~ the ability of APS to perform such activities as are necessary to safely and reliably operate and maintain the Transmission System. If the Interconnection Customer elects the CAISO as the Balancing Authority for a Project Phase, the CAISO may also have authority to require Interconnection Customer to curtail or interrupt such generation in accordance with the procedures established for generators in the CAISO Balancing Authority Area, in which case the procedures established by the CAISO pursuant to the CAISO Tariff shall apply in lieu of the provisions of this Article 9.7.2. APS or the CAISO shall notify the other as soon as possible of any curtailment, interruption, or reduction of deliveries from the Large Generating Facility that it may require. The following provisions shall apply to any interruption or reduction by APS permitted under this Article 9.7.2:

- 9.7.2.1** The interruption or reduction shall continue only for so long as reasonably necessary under Good Utility Practice;
- 9.7.2.2** Any such interruption or reduction shall be made on an equitable, non-discriminatory basis with respect to all generating facilities directly connected to ~~the~~its Transmission System;
- 9.7.2.3** When the interruption or reduction must be made under circumstances which do not allow for advance notice, ~~Transmission Provider~~APS shall notify Interconnection Customer by telephone as soon as practicable of the reasons for the curtailment, interruption, or reduction, and, if known, its expected duration. Telephone notification shall be followed by written notification, if requested by the Interconnection Customer, as soon as practicable;
- 9.7.2.4** Except during the existence of an Emergency Condition, when the interruption or reduction can be scheduled without advance notice, ~~Transmission Provider~~APS shall notify Interconnection Customer in advance regarding the timing of such scheduling and further notify Interconnection Customer of the expected duration. ~~Transmission Provider~~APS shall coordinate with Interconnection Customer using Good Utility Practice to schedule the interruption or reduction during periods of least impact to Interconnection Customer, and APS, acting on behalf of the Transmission ~~Provider~~Owners;
- 9.7.2.5** The Parties shall cooperate and coordinate with each other to the extent necessary in order to restore the Large Generating Facility, Interconnection Facilities, and ~~the~~their Transmission ~~System~~Systems to their normal operating state, consistent with system conditions and Good Utility Practice.
- 9.7.3 Under-Frequency and Over Frequency Conditions.** The Transmission System is designed to automatically activate a load-shed program as required by Applicable Reliability Standards and the Applicable Reliability Council in the event of an under-frequency system disturbance. Interconnection Customer shall implement under-frequency and over-frequency ~~relay~~protection set points for the Large Generating Facility as required by the Applicable Reliability Standards and Applicable Reliability Council to ensure "ride through" capability of the Transmission System. Large Generating Facility response to frequency deviations of pre-determined magnitudes, both under-frequency and over-frequency deviations, shall be studied and coordinated with ~~Transmission Provider~~APS and the CAISO in accordance with Good Utility Practice. The term "ride through" as used herein shall mean the ability of a Generating Facility to stay connected to and synchronized with the Transmission System during system disturbances within a range of under-frequency and over-frequency conditions, in accordance with Good Utility Practice.
- 9.7.4 System Protection and Other Control Requirements.**

9.7.4.1 System Protection Facilities. Interconnection Customer shall, at its expense, install, operate and maintain System Protection Facilities as a part of the Large Generating Facility or Interconnection Customer's Interconnection Facilities. Transmission ~~Provider~~Owners shall install at Interconnection Customer's expense any System Protection Facilities that may be required on Transmission ~~Provider's~~Owners' Interconnection Facilities ~~or the~~and their Transmission ~~System~~Systems as a result of the interconnection of the Large Generating Facility and Interconnection Customer's Interconnection Facilities.

9.7.4.2 ~~Each Party~~The Transmission Owners' and Interconnection Customer's protection facilities shall be designed and coordinated with other systems in accordance with Applicable Reliability Standards, Applicable Reliability Council criteria and Good Utility Practice.

9.7.4.3 ~~Each Party~~The Transmission Owners and Interconnection Customer shall be responsible for protection of ~~its~~their respective facilities consistent with Good Utility Practice.

9.7.4.4 ~~Each Party~~The Transmission Owners' and Interconnection Customer's protective relay design shall incorporate the necessary test switches to perform the tests required in Article 6. The required test switches will be placed such that they allow operation of lockout relays while preventing breaker failure schemes from operating and causing unnecessary breaker operations and/or the tripping of Interconnection Customer's units.

9.7.4.5 ~~Each Party will test, operate and maintain~~The Transmission Owners and Interconnection Customer will cause to be tested, operated and maintained System Protection Facilities in accordance with Good Utility Practice.

9.7.4.6 Prior to the ~~In-Service Date~~in-service date, and again prior to the Commercial Operation Date, ~~each Party or its agent~~the Transmission Owners and Interconnection Customer or their respective agents shall perform a complete calibration test and functional trip test of the System Protection Facilities. At intervals suggested by Good Utility Practice and following any apparent malfunction of the System Protection Facilities, ~~each Party~~the Transmission Owners and Interconnection Customer shall perform both calibration and functional trip tests of ~~its~~their respective System Protection Facilities. These tests do not require the tripping of any in-service generation unit. These tests do, however, require that all protective relays and lockout contacts be activated.

9.7.5 Requirements for Protection. In compliance with Good Utility Practice, Interconnection Customer shall provide, install, own, and maintain relays, circuit breakers and all other devices necessary to remove any fault contribution of the Large Generating Facility to any short circuit occurring on the Transmission

System not otherwise isolated by Transmission ~~Provider's~~Owners' respective equipment, such that the removal of the fault contribution shall be coordinated with the protective requirements of the Transmission System. Such protective equipment shall include, without limitation, a disconnecting device or switch with ~~load~~fault current-interrupting capability located between the Large Generating Facility and the ~~Transmission System~~JPP at a site selected upon mutual agreement (not to be unreasonably withheld, conditioned or delayed) of the Parties. Interconnection Customer shall be responsible for protection of the Large Generating Facility and Interconnection Customer's other equipment from such conditions as negative sequence currents, over- or under-frequency, sudden load rejection, over- or under-voltage, and generator loss-of-field. Interconnection Customer shall be solely responsible to disconnect the Large Generating Facility and Interconnection Customer's other equipment if conditions on the Transmission System could adversely affect the Large Generating Facility.

9.7.6 Power Quality. Neither Party's facilities shall cause excessive voltage flicker nor introduce excessive distortion to the sinusoidal voltage or current waves as defined by ANSI Standard C84.1-1989, in accordance with IEEE Standard 519, or any applicable superseding electric industry standard or Applicable Reliability Standard. In the event of a conflict ~~between~~among ANSI Standard C84.1-1989, ~~or any applicable superseding electric industry standard, ANSI Standard C84.1-1989, or the applicable superseding electric industry standard, or Applicable Reliability Standard, the Applicable Reliability Standard~~ shall control.

9.8 Switching and Tagging Rules. ~~Each Party~~APS, on behalf of Transmission Owners, and the Interconnection Customer shall provide ~~the each~~ other ~~Party~~ a copy of its switching and tagging rules that are applicable to the other ~~Party's~~ activities. Such switching and tagging rules shall be developed on a non-discriminatory basis. ~~The Parties~~APS, on behalf of Transmission Owners, and Interconnection Customer shall comply with applicable switching and tagging rules, as amended from time to time, in obtaining clearances for work or for switching operations on equipment.

9.9 Use of Interconnection Facilities by Third Parties.

9.9.1 Purpose of Interconnection Facilities. Except as may be required by Applicable Laws and Regulations, or as otherwise agreed to among the Parties, the Interconnection Facilities shall be constructed for the sole purpose of interconnecting the Large Generating Facility to the ~~Transmission System~~JPP and shall be used for no other purpose.

9.9.2 Third Party Users. If required by Applicable Laws and Regulations or if the Parties mutually agree, such agreement not to be unreasonably withheld, to allow one or more third parties to use Transmission ~~Provider's~~Owners' Interconnection Facilities, or any part thereof, Interconnection Customer will be entitled to compensation for the capital expenses it incurred in connection with the Interconnection Facilities based upon the pro rata use of the Interconnection Facilities by each Transmission ~~Provider~~Owner, ~~all~~ third party ~~users~~user, and

Interconnection Customer, in accordance with Applicable Laws and Regulations or upon some other mutually-agreed upon methodology. In addition, cost responsibility for ongoing costs, including operation and maintenance costs associated with the Interconnection Facilities, will be allocated between Interconnection Customer and any third party users based upon the pro rata use of the Interconnection Facilities by each Transmission ~~Provider~~Owner, ~~all~~ third party ~~users~~user, and Interconnection Customer, in accordance with Applicable Laws and Regulations or upon some other mutually agreed upon methodology. If the issue of such compensation or allocation cannot be resolved through such negotiations, it shall be submitted to ~~FERC for resolution~~arbitration pursuant to Article 27 of this Agreement or, if a complaint is made against a FERC jurisdictional public utility that is a Party to this Agreement, to FERC for resolution with respect to that FERC jurisdictional public utility.

- 9.10 Disturbance Analysis Data Exchange.** The Parties will cooperate with one another in the analysis of disturbances to either the Large Generating Facility or the Transmission ~~Provider's Transmission System~~Systems by gathering and providing access to any information relating to any disturbance, including information from oscillography, protective relay targets, breaker operations and sequence of events records, and any disturbance information required by Good Utility Practice.

Article 10. Maintenance

- 10.1 Transmission ~~Provider~~Owner Obligations.** Transmission ~~Provider~~Owners shall maintain the Transmission ~~System~~Owners' Transmission Systems and Transmission ~~Provider's~~Owners' Interconnection Facilities in a safe and reliable manner and in accordance with this LGIA Agreement.
- 10.2 Interconnection Customer Obligations.** Interconnection Customer shall maintain the Large Generating Facility and Interconnection Customer's Interconnection Facilities in a safe and reliable manner and in accordance with this LGIA Agreement.
- 10.3 Coordination.** ~~The Parties~~ APS, on behalf of Transmission Owners, Interconnection Customer and the CAISO shall confer regularly to coordinate the planning, scheduling and performance of preventive and corrective maintenance on the Large Generating Facility and the Interconnection Facilities, which maintenance coordination shall be consistent with Article 9.7.1.
- 10.4 Secondary Systems.** ~~Each Party~~ APS, on behalf of Transmission Owners, Interconnection Customer and the CAISO shall cooperate with ~~the~~each other in the inspection, maintenance, and testing of control or power circuits that operate below 600 volts, AC or DC, including, but not limited to, any hardware, control or protective devices, cables, conductors, electric raceways, secondary equipment panels, transducers, batteries, chargers, and voltage and current transformers that directly affect the operation of ~~a Party's~~such Parties' facilities and equipment which may reasonably be expected to impact the other ~~Party.~~ ~~Each Party~~ Parties. APS, on behalf of Transmission Owners, Interconnection Customer and the CAISO shall provide advance notice to ~~the~~each other ~~Party~~ before undertaking any work on such circuits, especially on electrical circuits

involving circuit breaker trip and close contacts, current transformers, or potential transformers.

- 10.5 Operating and Maintenance Expenses.** Subject to the provisions herein addressing the use of facilities by others, and except for operations and maintenance expenses associated with modifications made for providing interconnection or transmission service to a third party and such third party pays for such expenses, Interconnection Customer shall be responsible for all reasonable expenses including overheads, associated with: (1) owning, operating, maintaining, repairing, and replacing Interconnection Customer's Interconnection Facilities; and (2) operation, maintenance, repair and replacement of Transmission ~~Provider's~~Owners' Interconnection Facilities.

Article 11. Performance Obligation

- 11.1 Interconnection Customer Interconnection Facilities.** Interconnection Customer shall design, procure, construct, install, own and/or control Interconnection Customer Interconnection Facilities described in ~~Appendix A, Interconnection Facilities, Network Upgrades and Distribution Upgrades, Appendices A-1 and A-2~~ at its sole expense.
- 11.2 Transmission ~~Provider or Transmission Owner~~Owners' Interconnection Facilities.** APS, on behalf of Transmission ~~Provider or Transmission Owner~~Owners, shall design, procure, construct, install, own and/or control the Transmission ~~Provider's~~Owners' Interconnection Facilities described in ~~Appendix A, Interconnection Facilities, Network Upgrades and Distribution Upgrades, Appendices A-1 and A-2~~ at the sole expense of the Interconnection Customer.
- 11.3 Network Upgrades and Distribution Upgrades.** APS, on behalf of Transmission ~~Provider or Transmission Owner~~Owners shall design, procure, construct, and install, and the Transmission Owners shall jointly own the JPP Network Upgrades and Distribution Upgrades described in Appendices A-1 and A-2. SDG&E shall design, procure, construct, install, and own the ~~Network Upgrades and Distribution~~non-JPP Network Upgrades described in Appendix A, ~~Interconnection Facilities, Network Upgrades and Distribution Upgrades.~~ ~~The Interconnection Customer shall be responsible for all costs related to Distribution Upgrades.~~ ~~Unless Transmission Provider or Transmission Owner elects~~3. Unless Transmission Owners, individually or collectively, elect to fund the capital for the Network Upgrades, they shall be solely funded by Interconnection Customer. For Network Upgrades to SDG&E's Transmission System, including SDG&E's share of the JPP, the amount of Interconnection Customer's cost responsibility to SDG&E shall be determined pursuant to the methodology set forth in Section 12.3.1 and Appendix 2 of the CAISO's Large Generator Interconnection Procedures.
- 11.4 Transmission Credits.**
- 11.4.1 Repayment of Amounts Advanced to APS for Network Upgrades to APS's Share of the JPP.** Interconnection Customer shall be entitled to a cash repayment from APS, equal to the total amount paid by Interconnection Customer to Transmission ~~Provider and Affected System Operator, if any,~~Owners for the Network Upgrades, ~~including any tax gross up or other tax-related payments associated with Network Upgrades, to the JPP identified in~~

Appendices A-1 and A-2, and not refunded to Interconnection Customer pursuant to Article 5.17.8 or otherwise, times APS's percentage Ownership Interest in the JPP ("APS's pro rata amount"), plus any tax gross-up or other tax-related payments associated with APS's pro rata amount, to be paid to Interconnection Customer on a dollar-for-dollar basis for the non-usage sensitive portion of transmission charges, as payments are made under ~~Transmission Provider's~~ APS's Tariff ~~and Affected System's Tariff for~~ applicable to transmission services on APS's Transmission System with respect to the Large Generating Facility. ~~Any~~ Such repayment shall include interest calculated in accordance with the methodology set forth in FERC's regulations at 18 C.F.R. § 35.19a(a)(2)(iii) from the date of any payment for JPP Network Upgrades through the date on which the Interconnection Customer receives a repayment of such payment pursuant to this subparagraph. Interconnection Customer may assign such repayment rights to any person.

Notwithstanding the foregoing, Interconnection Customer, ~~Transmission Provider, and Affected System Operator~~ and APS may adopt any an alternative payment schedule that is mutually agreeable so long as ~~Transmission Provider and Affected System Operator take~~ APS takes one of the following actions no later than five years from the Commercial Operation Date for a Project Phase: (1) ~~return~~ returns to Interconnection Customer any of its pro rata amounts advanced for JPP Network Upgrades not previously repaid, or (2) ~~declare~~ declares in writing that ~~Transmission Provider or Affected System Operator~~ APS will continue to provide payments to Interconnection Customer on a dollar-for-dollar basis for the non-usage sensitive portion of transmission charges, or develop an alternative schedule that is mutually agreeable and provides for the return of all its pro rata amounts advanced for Network Upgrades not previously repaid; however, full reimbursement by APS of its pro rata amount shall not extend beyond twenty (20) years from the Commercial Operation Date for a Project Phase, and further, if this Agreement terminates within five (5) years from the Commercial Operation Date for that Project Phase, APS's obligation to pay refunds to the Interconnection Customer shall cease as of the date of termination.

If the Large Generating Facility fails to achieve ~~commercial~~ operation Commercial Operation for a Project Phase, but it or another Generating Facility is later constructed and makes use of the Network Upgrades, ~~Transmission Provider and Affected System Operator~~ to the JPP associated with that Project Phase, APS shall at that time reimburse Interconnection Customer for ~~the amounts~~ APS's pro rata amount advanced to it for the JPP Network Upgrades for the Project Phase. Before any such reimbursement can occur, the Interconnection Customer, or the entity that ultimately constructs the Generating Facility, if different, is responsible for identifying and demonstrating to APS the entity to which reimbursement must be made in order to implement the intent of this reimbursement obligation.

11.4.2 Repayment of Amounts Advanced to SDG&E for Network Upgrades to Its Share of the JPP and to Its Non-JPP Facilities.

Upon the Commercial Operation Date for a Project Phase, the Interconnection Customer shall be entitled to a repayment, equal to the total amount paid by Interconnection Customer to SDG&E for the Network Upgrades to the JPP identified in Appendices A-1 and A-2, and not refunded to Interconnection Customer pursuant to Article 5.17.8 or otherwise, times SDG&E's percentage Ownership Interest in the JPP ("SDG&E's pro rata amount"), plus any amount paid to SDG&E for the costs of Network Upgrades to non-JPP facilities owned by SDG&E set forth in Appendix A-3 and not refunded to Interconnection Customer pursuant to Article 5.17.8 or otherwise ("SDG&E's individual amount"), plus any tax gross-up or other tax-related payments associated with Network Upgrades and not refunded to the Interconnection Customer pursuant to Article 5.17.8 or otherwise, and shall be paid to the Interconnection Customer by SDG&E on a dollar-for-dollar basis either through (1) direct payments made on a levelized basis over the five-year period commencing on the Commercial Operation Date for a Project Phase; or (2) any alternative payment schedule that is mutually agreeable to the Interconnection Customer and SDG&E, provided that such amount is paid within five (5) years from the Commercial Operation Date for a Project Phase. See also Appendices A-1 and A-2. Notwithstanding the foregoing, if this Agreement terminates within five (5) years from the Commercial Operation Date for that Project Phase, SDG&E's obligation to pay refunds to the Interconnection Customer shall cease as of the date of termination. Any repayment shall include interest calculated in accordance with the methodology set forth in FERC's regulations at 18 C.F.R. §35.19a(a)(2)(iii) from the date of any payment for Network Upgrades through the date on which the Interconnection Customer receives a repayment of such payment. Interest shall continue to accrue on the repayment obligation so long as this Agreement is in effect. The Interconnection Customer may assign such repayment rights to any person.

If the Large Generating Facility fails to achieve Commercial Operation for a Project Phase, but it or another Generating Facility is later constructed and makes use of the Network Upgrades associated with that Project Phase, SDG&E shall at that time reimburse Interconnection Customer for SDG&E's pro rata amount and the individual amount advanced to SDG&E for the Network Upgrades for the Project Phase. Before any such reimbursement can occur, the Interconnection Customer, or the entity that ultimately constructs the Generating Facility, if different, is responsible for identifying and demonstrating to SDG&E the appropriate entity to which reimbursement must be made in order to implement the intent of this reimbursement obligation.

11.4.3 Repayment of Amounts Advanced to IID for Network Upgrades to IID's Share of the JPP. The Parties acknowledge that IID is not a jurisdictional public utility subject to FERC's rate jurisdiction under Section 205 or 206 of the Federal Power Act. The responsibility to provide transmission rate credits, under FERC's generation interconnection regulations, therefore does not extend to IID. See Order No. 2003-C, 111 FERC ¶ 61,401, at P 18 (2005)(citing Order No. 2003, 104 FERC ¶ 61,103, at P 843 (2003)). Notwithstanding its non-jurisdictional status, IID hereby agrees to provide transmission rate credits to

Interconnection Customer (or any other qualified person to whom Interconnection Customer assigns its rights to such transmission rate credits) when Point-to-Point Transmission Service is taken on IID's share of the JPP as follows: IID shall provide such rate credits in an amount equal to the total amount paid by Interconnection Customer to Transmission Owners for the Network Upgrades to the JPP identified in Appendices A-1 and A-2 and not refunded to Interconnection Customer pursuant to Article 5.17.8 or otherwise, times IID's percentage Ownership Interest in the JPP ("IID's pro rata amount"). Such rate credits shall be provided by IID on a dollar-for-dollar basis for the non-usage sensitive portion of IID's transmission charges (i.e., the demand charge for reserved capacity), as payments are made by Interconnection Customer (or any other qualified person to whom Interconnection Customer assigns its rights to transmission rate credits) to IID under IID's Open Access Transmission Tariff, for a period no longer than twenty (20) years from the Commercial Operation Date for a Project Phase. Notwithstanding the foregoing, if this Agreement terminates within five (5) years from the Commercial Operation Date for that Project Phase, IID's obligation to pay refunds to the Interconnection Customer shall cease as of the date of termination. IID also hereby agrees that Interconnection Customer may assign its rights to such transmission rate credits to any person which qualifies as an Eligible Customer for Point-to-Point Transmission Service under IID's Open Access Transmission Tariff.

If the Large Generating Facility fails to achieve Commercial Operation for a Project Phase, but it or another Generating Facility is later constructed and makes use of the Network Upgrades to the JPP associated with that Project Phase, IID shall reimburse Interconnection Customer for IID's pro rata amount advanced to it for the JPP Network Upgrades for the Project Phase, provided that IID receives payment of those amounts from the entity making use of the JPP Network Upgrades. Before any such reimbursement can occur, the Interconnection Customer, or the entity that ultimately constructs the Generating Facility, if different, is responsible for identifying and demonstrating to IID the appropriate entity to which reimbursement must be made in order to implement the intent of this reimbursement obligation.

11.4.2

11.4.4 Special Provisions for Affected Systems. ~~Unless Transmission Provider provides, under the LGIA, for the repayment of amounts advanced to Affected System Operator for Network Upgrades,~~ Interconnection Customer and any Affected System Operator shall enter into ~~an~~ a separate agreement that provides for ~~such~~ the repayment of amounts advanced to such Affected System Operator for Network Upgrades. The agreement shall specify the terms governing payments to be made by Interconnection Customer to the Affected System Operator as well as the repayment by the Affected System Operator.

The Parties acknowledge that an Affected System Study must be performed by IID to analyze system impacts and identify the Network Upgrades, if any, that are required to IID's Transmission System, including its non-JPP facilities, to accommodate Interconnection Requests received by the CAISO from interconnection customers in the CAISO's Transition Cluster, as defined in the

CAISO's LGIP, including the Interconnection Customer that is a Party to this Agreement. IID and Interconnection Customer have executed or will execute an Affected System Study Agreement for Phase A of the Generating Facility, whereby IID will perform and Interconnection Customer will pay the costs of an Affected System Study. The total costs will be pro rated to the extent IID performs the Affected System Study in a cluster for multiple generators seeking to interconnect to the CAISO controlled grid, with Interconnection Customer allocated a proportionate share of the total costs. Subject to the terms of a mutually-acceptable Non-Disclosure Agreement between the CAISO and IID, the CAISO shall provide to IID its applicable base case Interconnection Study data to assist IID in performing the Affected System Study.

The Parties acknowledge that there may be a need for an Affected System Study for Phase B of the Generating Facility, as provided for in Appendix C to this Agreement.

If an Affected System Study shows that Network Upgrades are required to IID's Transmission System, other than IID's share of the JPP, Interconnection Customer and IID agree that they shall enter into an Affected System Construction and Operation Agreement and that failure of the Interconnection Customer or IID to enter into such an agreement in accordance with the terms of this Article shall be considered a breach of this Agreement. The Interconnection Customer and IID agree that pursuant to the Affected System Construction and Operation Agreement: (1) Interconnection Customer shall fund the costs of constructing Network Upgrades reasonably attributable to Interconnection Customer; (2) IID shall use Reasonable Efforts to construct any Network Upgrades to IID's non-JPP facilities needed to accommodate Interconnection Customer's Interconnection Request to the CAISO on a schedule consistent with the provisions regarding testing in Article 6.1 of this Agreement; and (3) to the extent that the Interconnection Customer provides funding for any IID Network Upgrades identified in the Affected System Study, IID shall provide rate credits for the amount of such funding, which has not otherwise been refunded, applied on a dollar-for-dollar basis to the non-usage sensitive portion of IID's transmission charges (i.e., the demand charge for reserved capacity), as payments are made by Interconnection Customer (or any other qualified person to whom Interconnection Customer assigns its rights to transmission rate credits) under IID's Tariff, for a period no longer than twenty (20) years from the Commercial Operation Date for the Project Phase.

Any disputes between Interconnection Customer and IID regarding the Affected System Study Agreement or Affected System Construction and Operation Agreement shall be resolved pursuant to the dispute resolution procedures in Section 13.5 of the Generation Interconnection Procedures in IID's Tariff.

11.4.3

11.4.5 Notwithstanding any other provision of this ~~LGIA~~ Agreement, nothing herein shall be construed as relinquishing or foreclosing any rights, including but not limited to firm transmission rights, capacity rights, transmission congestion rights, "Congestion Revenue Rights" defined in and available pursuant to the

terms of the CAISO Tariff, or transmission credits, that Interconnection Customer, shall be entitled to, now or in the future, under any other agreement or tariff as a result of, or otherwise associated with, the transmission capacity, if any, created by the Network Upgrades, including the right to obtain cash reimbursements, merchant transmission “Congestion Revenue Rights” in accordance with Section 36.11 of the CAISO Tariff, or transmission credits for transmission service that is not associated with the Large Generating Facility.

- 11.5 Provision of Security.** ~~At~~ With regard to SDG&E’s share of costs to be incurred for Transmission Owners’ Interconnection Facilities and Network Upgrades to the JPP identified in Appendices A-1 and A-2, and for SDG&E’s costs of Network Upgrades identified in Appendix A-3, the Interconnection Customer shall provide (or cause to be provided) all necessary Interconnection Financial Security required under Section 9 of the CAISO’s LGIP in a manner acceptable under Section 9 of the CAISO’s LGIP. Failure to satisfy the CAISO’s LGIP’s requirements for the provision of Interconnection Financial Security shall result in the Interconnection Request being deemed withdrawn and subject to CAISO LGIP Section 3.8.

With regard to APS and IID’s shares of the costs to be incurred for Interconnection Facilities and Network Upgrades to the JPP identified in Appendices A-1 and A-2, at least thirty (30) Calendar Days prior to the commencement of the procurement, installation, or construction of ~~a discrete portion of a~~ Transmission ~~Provider’s Owners’~~ Interconnection Facilities; ~~and JPP~~ Network Upgrades, ~~or Distribution Upgrades, the~~ Interconnection Customer shall provide ~~Transmission Provider, at Interconnection Customer’s option~~ (or cause to be provided) APS, on behalf of APS and IID, a guarantee, a surety bond, letter of credit or other form of security that is reasonably acceptable to ~~Transmission Provider~~ APS and IID, and is consistent with the Uniform Commercial Code of the jurisdiction identified in Article 14.2.1. Such security for payment shall be in an amount sufficient to cover the costs for constructing, procuring and installing ~~the applicable portion of~~ both APS and IID’s shares of the Transmission ~~Provider’s Owners’~~ Interconnection Facilities; ~~and JPP~~ Network Upgrades, ~~or Distribution Upgrades set forth in Appendices A-1 and A-2,~~ and shall be reduced on a dollar-for-dollar basis for payments made to ~~Transmission Provider~~ APS, on behalf of APS and IID, for these purposes.

The Parties agree that APS, as the Operating Agent of the JPP under the Participation Agreement, and solely as agent for APS and IID, will accept delivery of the financial security required for the APS and IID shares of the Transmission Owners’ Interconnection Facilities and Network Upgrades to the JPP set forth in Appendices A-1 and A-2, which the Interconnection Customer is required to provide (or cause to be provided) in accordance with the milestone schedule set forth in Appendices B-1 and B-2. APS’s receipt of any such financial security will be solely as agent for APS and IID, and APS shall have no obligations to the Interconnection Customer with regard to such financial security other than any obligation it may have for the APS and IID shares of such financial security; APS shall have all obligations, if any, to the Interconnection Customer for the APS and IID shares of such financial security. If it becomes necessary for the Transmission Owners to enforce their financial security rights, APS shall do so, as

Operating Agent of the JPP, on behalf of APS and IID in accordance with the procedures set forth in Appendices A-1 and A-2.

SDG&E shall hold the Interconnection Financial Security required for SDG&E's Ownership Share in accordance with the requirements of the CAISO Tariff, provided, however, that if it becomes necessary for the Transmission Owners to enforce their financial security rights, SDG&E shall do so in accordance with the CAISO Tariff and the procedures set forth in Appendices A-1 and A-2.

In addition to complying with all requirements of the CAISO's Large Generator Interconnection Procedures regarding Interconnection Financial Security for security provided to SDG&E:

- 11.5.1 ~~The~~Any guarantee provided to APS, on behalf of APS and IID, and/or SDG&E, as applicable, must be made by an entity that meets the creditworthiness requirements of ~~Transmission Provider~~APS and IID and/or SDG&E, as applicable, and contain terms and conditions that guarantee payment of any amount that may be due from Interconnection Customer, up to an agreed-to maximum amount.
- 11.5.2 ~~The~~Any letter of credit to APS, on behalf of APS and IID, and/or SDG&E, , as applicable, must be issued by a financial institution reasonably acceptable to ~~Transmission Provider~~APS and IID and/or SDG&E, as applicable, and must specify a reasonable expiration date.
- 11.5.3 ~~The~~Any surety bond to APS, on behalf of APS and IID, and/or SDG&E, as applicable, must be issued by an insurer reasonably acceptable to ~~Transmission Provider~~APS and IID and/or SDG&E, as applicable, and must specify a reasonable expiration date.

Security shall be provided separately for Phase A of the Interconnection Project and Phase B of the Interconnection Project. Failure of the Interconnection Customer to have any required financial security in place at any time shall constitute grounds for termination of this Agreement pursuant to Articles 2.3 and 17.1, provided, however, Interconnection Customer shall have only 5 (five) Business Days to cure such failure following notice of the default. In addition to the foregoing, the obligation of Transmission Owners to perform under this Agreement is suspended until such failure is cured.

- 11.6 **Interconnection Customer Compensation.** If a Transmission ~~Provider~~Owner or the CAISO requests or directs Interconnection Customer to provide a service pursuant to ~~Articles 9.6.3 (Payment for Reactive Power), or~~ 13.5.1 of this ~~LGIA~~Agreement, the Transmission ~~Provider~~Owner or the CAISO requesting service shall compensate Interconnection Customer in accordance with ~~Interconnection Customer's applicable rate schedule then in effect unless the provision of such service(s) is subject to an RTO or ISO FERC approved rate schedule. Interconnection Customer shall serve Transmission Provider or RTO or ISO with any filing of a proposed rate schedule at the time of such filing with FERC. To the extent that no rate schedule is in effect at the time the~~

~~Interconnection Customer is required to provide or absorb any Reactive Power under this LGIA, Transmission Provider agrees to compensate Interconnection Customer in such amount as would have been due Interconnection Customer had the rate schedule been in effect at the time service commenced; provided, however, that such rate schedule must be filed at FERC or other appropriate Governmental Authority within sixty (60) Calendar Days of the commencement of service.~~its Tariff.

11.6.1 Interconnection Customer Compensation for Actions During Emergency Condition. ~~The~~ Transmission ~~Provider or RTO or ISO~~ Owner or the CAISO requesting the Interconnection Customer to provide service during an Emergency Condition shall compensate Interconnection Customer for its provision of real and reactive power and other Emergency Condition services that Interconnection Customer provides to support ~~the~~its Transmission System during an Emergency Condition in accordance with Article 11.6.

Article 12. Invoice

12.1 General. ~~Each~~ **Provisions.** For purposes of this Article, as between APS, on behalf of Transmission Owners of the JPP, and Interconnection Customer, each such Party shall submit to the other Party, on a monthly basis, invoices of amounts due for the preceding month— with respect to JPP facilities. As between SDG&E, as owner of certain non-JPP facilities under this Agreement, and Interconnection Customer, each such Party shall submit to the other Party, on a monthly basis, invoices of amounts due for the preceding month for such non-JPP facilities owned solely by SDG&E.

Each invoice shall state the month to which the invoice applies and fully describe the services and equipment provided. The Parties may discharge mutual debts and payment obligations due and owing to each other on the same date through netting, in which case all amounts a Party owes to the other Party under this ~~LGIA~~Agreement, including interest payments or credits, shall be netted so that only the net amount remaining due shall be paid by the owing Party: provided, however, that the Parties shall not net amounts relating to JPP facilities with those related to non-JPP facilities. Notwithstanding the foregoing, any invoices between the CAISO and another Party pursuant to the CAISO Tariff shall be submitted and paid in accordance with the CAISO Tariff.

Invoices shall be provided separately for Phase A of the Interconnection Project and Phase B of the Interconnection Project.

12.2 Final Invoice. Within six months after completion of the construction of Transmission ~~Provider's~~Owners' Interconnection Facilities and the Network Upgrades, ~~Transmission Provider shall~~ to the JPP for Phase A of the Interconnection Project and Phase B of the Interconnection Project, APS, on behalf of Transmission Owners, with respect to the Transmission Owners' Interconnection Facilities and JPP Network Upgrades identified in Appendices A-1 and A-2 and SDG&E with respect to its non-JPP Network Upgrades identified in Appendix A-3, shall each provide an invoice of the final cost of the construction of their respective Transmission ~~Provider's~~Owners' Interconnection Facilities and the Network Upgrades and shall set forth such costs in sufficient detail to

enable Interconnection Customer to compare the actual costs with the estimates and to ascertain deviations, if any, from the cost estimates. ~~Transmission Provider~~

With respect to costs associated with the Transmission Owners' Interconnection Facilities and the JPP Network Upgrades, APS, on behalf of Transmission Owners, shall refund to Interconnection Customer any amount by which the actual payment by Interconnection Customer for ~~the~~ estimated costs of such facilities exceeds the actual costs of construction within thirty (30) Calendar Days of the issuance of such final construction invoice; or, in the event the actual costs of construction exceed the Interconnection Customer's actual payment for estimated costs, then the Interconnection Customer shall pay to APS, on behalf of the Transmission Owners, any amount by which the actual costs of construction exceed the actual payment by the Interconnection Customer for the estimated costs within thirty (30) Calendar Days of the issuance of such final construction invoice.

With respect to costs associated with SDG&E's non-JPP Network Upgrades identified in Appendix A-3, SDG&E shall be responsible for refunding to the Interconnection Customer any amount by which the actual payment by the Interconnection Customer for estimated costs of such facilities exceeds the actual costs of construction, within thirty (30) Calendar Days of the issuance of such final construction invoice. In the event the actual costs of construction multiplied by the Interconnection Customer's percentage share of those costs exceed the Interconnection Customer's actual payment for estimated costs, then SDG&E shall be responsible for recovering such difference through its transmission service rates.

Invoices shall be provided separately for Phase A of the Interconnection Project and Phase B of the Interconnection Project.

- 12.3 Payment.** Invoices shall be rendered to the paying Party at the address specified in Appendix F. The Party receiving the invoice shall pay the invoice within thirty (30) Calendar Days of receipt. All payments shall be made in immediately available funds payable to the other Party, or by wire transfer to a bank named and account designated by the invoicing Party. Payment of invoices by either Party will not constitute a waiver of any rights or claims either Party may have under this ~~LGIA Agreement~~.
- 12.4 Disputes.** In the event of a billing dispute between Transmission ~~Provider Owners~~ and Interconnection Customer, Transmission ~~Provider Owners and the CAISO~~ shall continue to provide Interconnection Service under this ~~LGIA Agreement~~ as long as Interconnection Customer: (i) continues to make all payments not in dispute; and (ii) pays to Transmission ~~Provider Owners~~ or into an independent escrow account the portion of the invoice in dispute, pending resolution of such dispute. If Interconnection Customer fails to meet these two requirements for continuation of service, then Transmission ~~Provider Owners~~ may provide notice to Interconnection Customer of a Default pursuant to Article 17. Within thirty (30) Calendar Days after the resolution of the dispute, the Party that owes money to the other Party shall pay the amount due with interest calculated in accord with the methodology set forth in FERC's regulations at 18 CFR § 35.19a(a)(2)(iii). Notwithstanding the foregoing, any billing dispute between the CAISO,

Interconnection Customer and/or SDG&E shall be resolved in accordance with the provisions of Article 27 of this Agreement.

Article 13. Emergencies

~~13.1 — Definition. "Emergency Condition" shall mean a condition or situation: (i) that in the judgment of the Party making the claim is imminently likely to endanger life or property; or (ii) that, in the case of Transmission Provider, is imminently likely (as determined in a non-discriminatory manner) to cause a material adverse effect on the security of, or damage to the Transmission System, Transmission Provider's Interconnection Facilities or the Transmission Systems of others to which the Transmission System is directly connected; or (iii) that, in the case of Interconnection Customer, is imminently likely (as determined in a non-discriminatory manner) to cause a material adverse effect on the security of, or damage to, the Large Generating Facility or Interconnection Customer's Interconnection Facilities' System restoration and black start shall be considered Emergency Conditions; provided, that Interconnection Customer is not obligated by this LGIA to possess black start capability.~~

13.1 Definition. "Emergency Condition" shall have the meaning set forth in Article 1.

13.2 **Obligations.** ~~Each Party~~ Interconnection Customer, SDG&E and the CAISO shall comply with the Emergency Condition procedures of the ~~applicable ISO/RTO, CAISO,~~ and all Parties shall comply with the Emergency Condition procedures of NERC, the Applicable Reliability Council, Applicable Reliability Standards, Applicable Laws and Regulations, and any emergency procedures set forth in this Agreement or agreed to by the Joint Operating Committee, ~~that are consistent with the other Emergency Condition procedures with which compliance is required by this Article 13.2.~~

13.3 **Notice.** With respect to any facility which a Transmission ~~Provider~~Owner or the CAISO controls, the Transmission Owner or the CAISO shall notify Interconnection Customer promptly when it becomes aware of an Emergency Condition that affects Transmission ~~Provider's~~Owners' Interconnection Facilities or ~~the~~such Transmission Owner's or the CAISO's Transmission System that may reasonably be expected to affect Interconnection Customer's operation of the Large Generating Facility or Interconnection Customer's Interconnection Facilities. Interconnection Customer shall notify Transmission ~~Provider~~Owners and the CAISO promptly when it becomes aware of an Emergency Condition that affects the Large Generating Facility or Interconnection Customer's Interconnection Facilities that may reasonably be expected to affect the Transmission ~~System~~Systems or Transmission ~~Provider's~~Owners' Interconnection Facilities. To the extent information is known, the notification shall describe the Emergency Condition, the extent of the damage or deficiency, the expected effect on the operation of Interconnection Customer's or such Transmission ~~Provider~~Owner's or the CAISO's facilities and operations, its anticipated duration and the corrective action taken and/or to be taken. The initial notice shall be followed as soon as practicable with written notice, if requested by a Party, which may be provided by electronic mail or facsimile, or in the case of the CAISO may be publicly posted on the CAISO's internet website.

13.4 Immediate Action. Unless, in Interconnection Customer's reasonable judgment, immediate action is required, Interconnection Customer shall obtain the consent of ~~Transmission Provider~~APS and the CAISO, such consent to not be unreasonably withheld, prior to performing any manual switching operations at the Large Generating Facility or Interconnection Customer's Interconnection Facilities in response to an Emergency Condition either declared by APS, on behalf of the ~~Transmission Provider~~Owners, or the CAISO or otherwise regarding the ~~Transmission System~~Systems.

13.5 Transmission ~~Provider~~Owner and CAISO Authority.

13.5.1 General. Transmission ~~Provider~~Owners and the CAISO may take whatever actions or inactions with regard to ~~the~~their affected ~~Transmission System~~Systems or Transmission ~~Provider's~~Owners' Interconnection Facilities ~~it deems~~they deem necessary during an Emergency Condition in order to (i) preserve public health and safety, (ii) preserve the reliability of the affected ~~Transmission System~~Systems or Transmission ~~Provider's~~Owners' Interconnection Facilities, (iii) limit or prevent damage, and (iv) expedite restoration of service.

Transmission ~~Provider~~Owners and the CAISO shall use Reasonable Efforts to minimize the effect of such actions or inactions on the Large Generating Facility or Interconnection Customer's Interconnection Facilities. APS, on behalf of ~~Transmission Provider~~Owners, and the CAISO may, on the basis of technical considerations, require the Large Generating Facility to mitigate an Emergency Condition by taking actions necessary and limited in scope to remedy the Emergency Condition, including, but not limited to, directing Interconnection Customer to shut-down, start-up, increase or decrease the real or reactive power output of the Large Generating Facility; implementing a reduction or disconnection pursuant to Article 13.5.2; directing Interconnection Customer to assist with blackstart (if available) or restoration efforts; or altering the outage schedules of the Large Generating Facility and Interconnection Customer's Interconnection Facilities. Subject to the provisions of Articles 9.6.1 and 9.6.2, Interconnection Customer shall comply with all of ~~Transmission Provider's~~APS's operating instructions concerning Large Generating Facility real power and reactive power output within the manufacturer's design limitations of the Large Generating Facility's equipment that is in service and physically available for operation at the time, in compliance with Applicable Laws and Regulations and Applicable Reliability Standards.

13.5.2 Reduction and Disconnection. APS, on behalf of Transmission ~~Provider~~Owners, or the CAISO may reduce Interconnection Service ~~or,~~ and APS may disconnect the Large Generating Facility or Interconnection Customer's Interconnection Facilities, when such ~~reduction or disconnection~~ reduction or disconnection is necessary under Good Utility Practice due to Emergency Conditions. These rights are separate and distinct from any right of curtailment of Transmission ~~Provider~~Owners or the CAISO pursuant to ~~Transmission Provider's Tariff~~their respective Tariffs. When APS, on behalf of Transmission ~~Provider~~Owners, or the CAISO can schedule the reduction or disconnection in advance, ~~Transmission~~

~~Provider~~APS or the CAISO shall notify Interconnection Customer of the reasons, timing and expected duration of the reduction or disconnection. ~~Transmission Provider~~ and shall coordinate with the other in accordance with Articles 9.7.1 and 9.7.2. APS and the CAISO shall coordinate with Interconnection Customer using Good Utility Practice to schedule the reduction or disconnection during periods of least impact to Interconnection Customer and Transmission ~~Provider~~Owners and the CAISO. Any reduction or disconnection shall continue only for so long as reasonably necessary under Good Utility Practice. The Parties shall cooperate with each other to restore the Large Generating Facility, the Interconnection Facilities, and the Transmission System to their normal operating state as soon as practicable consistent with Good Utility Practice.

13.6 Interconnection Customer Authority. Consistent with Good Utility Practice ~~and the LGIA and the LGIP,~~ this Agreement and applicable Tariffs, Interconnection Customer may take actions or inactions with regard to the Large Generating Facility or Interconnection Customer's Interconnection Facilities during an Emergency Condition in order to (i) preserve public health and safety, (ii) preserve the reliability of the Large Generating Facility or Interconnection Customer's Interconnection Facilities, (iii) limit or prevent damage, and (iv) expedite restoration of service. Interconnection Customer shall use Reasonable Efforts to minimize the effect of such actions or inactions on the affected Transmission System(s) and Transmission ~~Provider's~~Owners' Interconnection Facilities. Each affected Transmission ~~Provider~~Owner and the CAISO shall use Reasonable Efforts to assist Interconnection Customer in such actions.

13.7 Limited Liability. Except as otherwise provided in Article 11.6.1 of this LGIA Agreement, ~~neither~~no Party shall be liable to the ~~other~~others for any action it takes in responding to an Emergency Condition so long as such action is made in good faith and is consistent with Good Utility Practice.

Article 14. Regulatory Requirements and Governing Law

14.1 Regulatory Requirements. ~~Each~~A Party's obligations under this LGIA Agreement shall be subject to its receipt of any required approval or certificate from one or more Governmental Authorities in the form and substance satisfactory to the applying Party, or the Party making any required filings with, or providing notice to, such Governmental Authorities, and the expiration of any time period associated therewith. ~~Each~~A Party shall in good faith seek and use its Reasonable Efforts to obtain such other approvals. Nothing in this LGIA Agreement shall require Interconnection Customer or other Party to take any action that could result in its inability to obtain, or its loss of, status or exemption under the Federal Power Act, the Public Utility Holding Company Act of 1935, as amended, or the Public Utility Regulatory Policies Act of 1978.

14.2 Governing Law.

14.2.1 The validity, interpretation and performance of this LGIA Agreement and each of its provisions shall be governed by the laws of the state where the Point of Interconnection is located, without regard to its conflicts of law principles.

~~14.2.2~~ This LGIA Agreement is subject to all Applicable Laws and Regulations.

~~14.2.3~~ Each Party expressly reserves the right to seek changes in, appeal, or otherwise contest any laws, orders, rules, or regulations of a Governmental Authority.

Article 15. Notices.

~~15.1~~ **General.** Unless otherwise provided in this LGIA Agreement, any notice, demand or request required or permitted to be given by ~~either a~~ Party to the ~~other others~~ and any instrument required or permitted to be tendered or delivered by ~~either a~~ Party in writing to the ~~other others~~ shall be effective when delivered and may be so given, tendered or delivered, by recognized national courier, or by depositing the same with the United States Postal Service with postage prepaid, for delivery by certified or registered mail, addressed to the Party Parties, or personally delivered to the Party Parties, at the address set out in Appendix F, Addresses for Delivery of Notices and Billings.

~~Either~~ A Party must update the information in Appendix F as information changes. A Party may change the notice information in this LGIA Agreement by giving five (5) Business Days written notice prior to the effective date of the change. Such changes shall not constitute an amendment to this Agreement.

~~15.2~~ **Billings and Payments.** Billings and payments shall be sent to the addresses set out in Appendix F.

~~15.3~~ **Alternative Forms of Notice.** Any notice or request required or permitted to be given by a Party to the other and not required by this Agreement to be given in writing may be so given by telephone, facsimile or email to the telephone numbers and email addresses set out in Appendix F.

~~15.4~~ **Operations and Maintenance Notice .** ~~Each Party~~ APS and the CAISO shall notify the other Party Parties in writing of the identity of the person(s) that ~~it designates~~ they designate as the point(s) of contact with respect to the implementation of Articles 9 and 10.

Article 16. Force Majeure

16.1 Force Majeure.

~~16.1.1~~ Economic hardship is not considered a Force Majeure event.

~~16.1.2~~ ~~Neither~~ No Party shall be considered to be in Default with respect to any obligation hereunder, (including obligations under Article 4), other than the obligation to pay money when due, if prevented from fulfilling such obligation by Force Majeure. A Party unable to fulfill any obligation hereunder (other than an obligation to pay money when due) by reason of Force Majeure shall give notice and the full particulars of such Force Majeure to the other Party Parties in writing or by telephone as soon as reasonably possible after the occurrence of the cause relied upon. Telephone notices given pursuant to this article shall be

confirmed in writing as soon as reasonably possible and shall specifically state full particulars of the Force Majeure, the time and date when the Force Majeure occurred and when the Force Majeure is reasonably expected to cease. The Party affected shall exercise due diligence to remove such disability with reasonable dispatch, but shall not be required to accede or agree to any provision not satisfactory to it in order to settle and terminate a strike or other labor disturbance.

Article 17. Default

17.1 Default

17.1.1 General. No Default shall exist where such failure to discharge an obligation (other than the payment of money or posting of security) is the result of Force Majeure as defined in this LGIA Agreement or the result of an act of omission of the other ~~Party~~Parties. Upon a Breach, the ~~affected non-breaching Party~~Breaching Parties shall give written notice of such Breach to the ~~breaching Breaching~~ Party. Except as provided in Article 17.1.2, the ~~breaching Breaching~~ Party shall have thirty (30) Calendar Days from receipt of the Default notice within which to cure such Breach; provided however, if such Breach is not capable of cure within thirty (30) Calendar Days, the ~~breaching Breaching~~ Party shall commence such cure within thirty (30) Calendar Days after notice and continuously and diligently complete such cure within ninety (90) Calendar Days from receipt of the Default notice; and, if cured within such time, the Breach specified in such notice shall cease to exist. If one but not both of the entities comprising the Interconnection Customer breaches this Agreement, the non-Breaching Party shall accept performance from the Interconnection Customer entity to the extent it continues to perform under this Agreement.

17.1.2 Right to Terminate. If a Breach is not cured as provided in this article or as provided in Article 11.5.3 with respect to the posting of financial security, or if a Breach is not capable of being cured within the period provided for herein, ~~the an affected~~ non-~~breaching Breaching~~ Party shall have the right to declare a Default and terminate this LGIA Agreement by written notice at any time until cure occurs, and be relieved of any further obligation hereunder and, whether or not that Party terminates this LGIA Agreement, to recover from the ~~breaching Breaching~~ Party all amounts due hereunder, plus all other damages and remedies to which it is entitled at law or in equity. The provisions of this article will survive termination of this LGIA Agreement.

Article 18. Indemnity, Consequential Damages and Insurance

18.1 Indemnity. ~~The Parties~~ A Party shall at all times indemnify, defend, and hold ~~the other another~~ Party, harmless from, any and all ~~damages, losses, claims, including claims and actions relating to injury to or death of any person or damage to property, demand, suits, recoveries, costs and expenses, court costs, attorney fees, and all other obligations by or to third parties.~~ Losses arising out of or resulting from ~~the other that particular~~

Party's ~~action~~ actions or inactions of its obligations under this LGIA Agreement on behalf of the Indemnifying indemnifying Party, except in cases of gross negligence or intentional wrongdoing by the Indemnified indemnified Party.

18.1.1 Indemnified Person Party. If an Indemnified Person indemnified Party is entitled to indemnification under this Article 18 as a result of a claim by a third party, and the Indemnifying indemnifying Party fails, after notice and reasonable opportunity to proceed under Article 18.1, to assume the defense of such claim, such Indemnified Person indemnified Party may at the expense of the Indemnifying indemnifying Party contest, settle or consent to the entry of any judgment with respect to, or pay in full, such claim.

18.1.2 Indemnifying Party. If an Indemnifying indemnifying Party is obligated to indemnify and hold any Indemnified Person indemnified Party harmless under this Article 18, the amount owing to the Indemnified Person indemnified Party shall be the amount of such Indemnified Person indemnified Party's actual Loss, net of any insurance or other recovery.

18.1.3 Indemnity Procedures. Promptly after receipt by an Indemnified Person indemnified Party of any claim or notice of the commencement of any action or administrative or legal proceeding or investigation as to which the indemnity provided for in Article 18.1 may apply, the Indemnified Person indemnified Party shall notify the Indemnifying indemnifying Party of such fact. Any failure of or delay in such notification shall not affect a Party's indemnification obligation unless such failure or delay is materially prejudicial to the Indemnifying indemnifying Party.

The Indemnifying indemnifying Party shall have the right to assume the defense thereof with counsel designated by such Indemnifying indemnifying Party and reasonably satisfactory to the Indemnified Person indemnified Party. If the defendants in any such action include one or more Indemnified Persons indemnified Parties and the Indemnifying indemnifying Party and if the Indemnified Person indemnified Party reasonably concludes that there may be legal defenses available to it and/or other Indemnified Persons indemnified Parties which are different from or additional to those available to the Indemnifying indemnifying Party, the Indemnified Person indemnified Party shall have the right to select separate counsel to assert such legal defenses and to otherwise participate in the defense of such action on its own behalf. In such instances, the Indemnifying indemnifying Party shall only be required to pay the fees and expenses of one additional attorney to represent an Indemnified Person or Indemnified Persons indemnified Party or indemnified Parties having such differing or additional legal defenses.

The Indemnified Person indemnified Party shall be entitled, at its expense, to participate in any such action, suit or proceeding, the defense of which has been assumed by the Indemnifying indemnifying Party. Notwithstanding the foregoing, the Indemnifying indemnifying Party (i) shall not be entitled to assume and control the defense of any such action, suit or proceedings if and to the extent

that, in the opinion of the ~~Indemnified Person~~indemnified Party and its counsel, such action, suit or proceeding involves the potential imposition of criminal liability on the ~~Indemnified Person~~indemnified Party, or there exists a conflict or adversity of interest between the ~~Indemnified Person~~indemnified Party and the ~~Indemnifying~~indemnifying Party, in such event the ~~Indemnifying~~indemnifying Party shall pay the reasonable expenses of the ~~Indemnified Person~~indemnified Party, and (ii) shall not settle or consent to the entry of any judgment in any action, suit or proceeding without the consent of the ~~Indemnified Person~~indemnified Party, which shall not be reasonably withheld, conditioned or delayed.

- 18.2 Consequential Damages.** ~~Other than the Liquidated Damages heretofore described, in~~In no event shall ~~either a~~a Party be liable under any provision of this LGIA Agreement for any losses, damages, costs or expenses for any special, indirect, incidental, consequential, or punitive damages, including but not limited to loss of profit or revenue, loss of the use of equipment, cost of capital, cost of temporary equipment or services, whether based in whole or in part in contract, in tort, including negligence, strict liability, or any other theory of liability; provided, however, that damages for which a Party may be liable to ~~the other~~another Party under another agreement will not be considered to be special, indirect, incidental, or consequential damages hereunder.
- 18.3 Insurance.** ~~Each party~~A Party shall, at its own expense, maintain in force throughout the period of this LGIA Agreement, and until released by the other Party(ies), the following minimum insurance coverages, with insurers authorized to do business in the state where the Point of Interconnection is located:
- 18.3.1 ~~Employers'~~Employer's** Liability and Workers' Compensation Insurance providing statutory benefits in accordance with the laws and regulations of the state in which the Point of Interconnection is located, except in the case of the CAISO, the State of California.
- 18.3.2** Commercial General Liability Insurance including premises and operations, personal injury, broad form property damage, broad form blanket contractual liability coverage (including coverage for the contractual indemnification) products and completed operations coverage, coverage for explosion, collapse and underground hazards, independent contractors coverage, coverage for pollution to the extent normally available and punitive damages to the extent normally available and a cross liability endorsement, with minimum limits of One Million Dollars (\$1,000,000) per occurrence/One Million Dollars (\$1,000,000) aggregate combined single limit for personal injury, bodily injury, including death and property damage.
- 18.3.3 ~~Comprehensive~~Business** Automobile Liability Insurance for coverage of owned and non-owned and hired vehicles, trailers or semi-trailers designed for travel on public roads, with a minimum, combined single limit of One Million Dollars (\$1,000,000) per occurrence for bodily injury, including death, and property damage.

- 18.3.4** Excess Public Liability Insurance over and above the ~~Employers'~~Employer's Liability Commercial General Liability and ~~Comprehensive~~Business Automobile Liability Insurance coverage, with a minimum combined single limit of Twenty Million Dollars (\$20,000,000) per occurrence/Twenty Million Dollars (\$20,000,000) aggregate.
- 18.3.5** The Commercial General Liability Insurance, ~~Comprehensive~~Business Automobile Insurance and Excess Public Liability Insurance policies shall name the other Party, ~~its parent~~their parents, associated and Affiliate companies and their respective directors, officers, agents, servants and employees ("Other Party Group") as additional insured. All policies shall contain provisions whereby the insurers waive all rights of subrogation in accordance with the provisions of this ~~LGIA~~Agreement against the Other Party Group and provide thirty (30) ~~Calendar~~Calendar Days advance written notice to the Other Party Group prior to anniversary date of cancellation or any material change in coverage or condition.
- 18.3.6** The Commercial General Liability Insurance, ~~Comprehensive~~Business Automobile Liability Insurance and Excess Public Liability Insurance policies shall contain provisions that specify that the policies are primary and shall apply to such extent without consideration for other policies separately carried and shall state that each insured is provided coverage as though a separate policy had been issued to each, except the insurer's liability shall not be increased beyond the amount for which the insurer would have been liable had only one insured been covered. Each Party shall be responsible for its respective deductibles or retentions.
- 18.3.7** The Commercial General Liability Insurance, ~~Comprehensive~~Business Automobile Liability Insurance and Excess Public Liability Insurance policies, if written on a Claims First Made Basis, shall be maintained in full force and effect for two (2) years after termination of this ~~LGIA~~Agreement, which coverage may be in the form of tail coverage or extended reporting period coverage if agreed by the Parties.
- 18.3.8** The requirements contained herein as to the types and limits of all insurance to be maintained by the Parties are not intended to and shall not in any manner, limit or qualify the liabilities and obligations assumed by the Parties under this ~~LGIA~~Agreement.
- 18.3.9** Within ten (10) ~~days~~Calendar Days following execution of this ~~LGIA~~Agreement, and as soon as practicable after the end of each fiscal year or at the renewal of the insurance policy and in any event within ninety (90) ~~days~~Calendar Days thereafter, each Party shall provide certification of all insurance required in this ~~LGIA~~Agreement, executed by each insurer or by an authorized representative of each insurer.
- 18.3.10** Notwithstanding the foregoing, each Party may self-insure to meet the minimum insurance requirements of Articles 18.3.2 through 18.3.8 to the extent it maintains a self-insurance program; provided that, such Party's senior ~~secured~~

~~debt is rated at investment grade~~unsecured debt or issuer rating is BBB-, or better as rated by Standard & Poor's and that its self-insurance program meets the minimum insurance requirements of Articles 18.3.2 through 18.3.8. For any period of time that a Party's senior ~~secured debt is unrated by Standard & Poor's or is~~unsecured debt rating and issuer rating are both rated at less than ~~investment grade~~BBB- by Standard & Poor's, such Party shall comply with the insurance requirements applicable to it under Articles 18.3.2 through 18.3.9. In the event that a Party is permitted to self-insure pursuant to this article, it shall notify the other PartyParties that it meets the requirements to self-insure and that its self-insurance program meets the minimum insurance requirements in a manner consistent with that specified in Article 18.3.9.

18.3.11 The Parties agree to report to each other in writing as soon as practical all accidents or occurrences resulting in injuries to any person, including death, and any property damage arising out of this LGIA Agreement.

Article 19. Assignment

19.1 Assignment. This LGIA Agreement may be assigned by ~~either~~a Party only with the written consent of the other Parties; provided that ~~either~~a Party may assign this LGIA Agreement without the consent of the other PartyParties to any Affiliate of the assigning Party with an equal or greater credit rating and with the legal authority and operational ability to satisfy the obligations of the assigning Party under this LGIA Agreement; and provided further that Interconnection Customer shall have the right to assign this LGIA Agreement, without the consent of ~~Transmission Provider~~the other Parties, for collateral security purposes to aid in providing financing for the Large Generating Facility or a Project Phase of the Large Generating Facility, provided that Interconnection Customer will promptly notify ~~Transmission Provider~~the Parties of any such assignment. Any financing arrangement entered into by Interconnection Customer pursuant to this article will provide that prior to or upon the exercise of the secured party's, trustee's or mortgagee's assignment rights pursuant to said arrangement, the secured creditor, the trustee or mortgagee will notify ~~Transmission Provider~~the Parties of the date and particulars of any such exercise of assignment right(s), including providing the ~~Transmission Provider~~Parties with proof that it meets the requirements of Articles 11.5 and 18.3. Any attempted assignment that violates this article is void and ineffective. Any assignment under this LGIA Agreement shall not relieve a Party of its obligations, nor shall a Party's obligations be enlarged, in whole or in part, by reason thereof. Where required, consent to assignment will not be unreasonably withheld, conditioned or delayed.

Article 20. Severability

20.1 Severability. If any provision in this LGIA Agreement is finally determined to be invalid, void or unenforceable by any court or other Governmental Authority having jurisdiction, such determination shall not invalidate, void or make unenforceable any other provision, agreement or covenant of this LGIA Agreement; provided that if Interconnection Customer (or any third party, but only if such third party is not acting at the direction of a Transmission ProviderOwner or the CAISO) seeks and obtains such a

final determination with respect to any provision of the Alternate Option (Article 5.1.2), or the Negotiated Option (Article 5.1.4), then none of these provisions shall thereafter have any force or effect and the Parties' rights and obligations shall be governed solely by the Standard Option (Article 5.1.1).

Article 21. Comparability

21.1 Comparability. The Parties which are FERC-jurisdictional public utilities will comply with all applicable comparability and code of conduct laws, rules and regulations, as amended from time to time. For clarity and avoidance of ambiguity, IID is not a jurisdictional public utility to whom Section 205 or 206 of the Federal Power Act or FERC rules and regulations thereunder apply.

Article 22. Confidentiality

22.1 Confidentiality. Confidential Information shall include, without limitation, all information relating to a Party's technology, research and development, business affairs, and pricing, and any information supplied by either any of the Parties to the other prior to the execution of this LGIA Agreement.

Information is Confidential Information only if it is clearly designated or marked in writing as confidential on the face of the document, or, if the information is conveyed orally or by inspection, if the Party providing the information orally informs the Party Parties receiving the information that the information is confidential.

If requested by either any Party, the other Party Parties shall provide in writing, the basis for asserting that the information referred to in this Article 22 warrants confidential treatment, and the requesting Party may disclose such writing to the appropriate Governmental Authority. Each Party shall be responsible for the costs associated with affording confidential treatment to its information.

22.1.1 Term. During the term of this LGIA Agreement, and for a period of three (3) years after the expiration or termination of this LGIA Agreement, except as otherwise provided in this Article 22, each Party shall hold in confidence and shall not disclose to any person Confidential Information.

22.1.2 Scope. Confidential Information shall not include information that the receiving Party can demonstrate: (1) is generally available to the public other than as a result of a disclosure by the receiving Party; (2) was in the lawful possession of the receiving Party on a non-confidential basis before receiving it from the disclosing Party; (3) was supplied to the receiving Party without restriction by a third party, who, to the knowledge of the receiving Party after due inquiry, was under no obligation to the disclosing Party to keep such information confidential; (4) was independently developed by the receiving Party without reference to Confidential Information of the disclosing Party; (5) is, or becomes, publicly known, through no wrongful act or omission of the receiving Party or Breach of this LGIA Agreement; or (6) is required, in accordance with Article 22.1.7 of the LGIA Agreement, Order of Disclosure, to be disclosed by any Governmental

Authority or is otherwise required to be disclosed by law or subpoena, or is necessary in any legal proceeding establishing rights and obligations under this [LGIA Agreement](#). Information designated as Confidential Information will no longer be deemed confidential if the Party that designated the information as confidential notifies the other [Party Parties](#) that it no longer is confidential.

- 22.1.3 Release of Confidential Information.** ~~Neither~~[No](#) Party shall release or disclose Confidential Information to any other person, except to its Affiliates (limited by the Standards of Conduct requirements [set forth in Part 358 of FERC's Regulations, 18 C.F.R. 358](#)), subcontractors, employees, consultants, or to parties who may be or considering providing financing to or equity participation with Interconnection Customer, or to potential purchasers or assignees of Interconnection Customer, on a need-to-know basis in connection with this [LGIA Agreement](#), unless such person has first been advised of the confidentiality provisions of this Article 22 and has agreed to comply with such provisions. Notwithstanding the foregoing, a Party providing Confidential Information to any person shall remain primarily responsible for any release of Confidential Information in contravention of this Article 22.
- 22.1.4 Rights.** Each Party retains all rights, title, and interest in the Confidential Information that each Party discloses to the other [Party Parties](#). The disclosure by each Party to the other [Party Parties](#) of Confidential Information shall not be deemed a waiver by ~~either~~[a](#) Party or any other person or entity of the right to protect the Confidential Information from public disclosure.
- 22.1.5 No Warranties.** By providing Confidential Information, ~~neither~~[no](#) Party makes any warranties or representations as to its accuracy or completeness. In addition, by supplying Confidential Information, ~~neither~~[no](#) Party obligates itself to provide any particular information or Confidential Information to the other [Party Parties](#) nor to enter into any further agreements or proceed with any other relationship or joint venture.
- 22.1.6 Standard of Care.** ~~Each~~[A](#) Party shall use at least the same standard of care to protect Confidential Information it receives as it uses to protect its own Confidential Information from unauthorized disclosure, publication or dissemination. ~~Each~~[A](#) Party may use Confidential Information solely to fulfill its obligations to the other [Party Parties](#) under this [LGIA Agreement](#) or its regulatory requirements.
- 22.1.7 ~~Order of Disclosure~~ [Required by Law or Order](#).** If a court or a Government Authority or entity with the right, power, and apparent authority to do so requests or requires ~~either~~[a](#) Party, by subpoena, oral deposition, interrogatories, requests for production of documents, administrative order, or otherwise, to disclose Confidential Information, that Party shall provide the other [Party Parties](#) with prompt notice of such request(s) or requirement(s) so that the other [Party Parties](#) may seek an appropriate protective order or waive compliance with the terms of this [LGIA Agreement](#). Notwithstanding the absence of a protective order or waiver, the Party may disclose such Confidential Information which, in the

opinion of its counsel, the Party is legally compelled to disclose. ~~Each, including any Confidential Information that, in the opinion of IID's counsel, IID is legally compelled to disclose under California public record laws.~~ A Party will use Reasonable Efforts to obtain reliable assurance that confidential treatment will be accorded any Confidential Information so furnished.

- 22.1.8 Termination of Agreement.** Upon termination of this [LGIA Agreement](#) for any reason, each Party shall, within ten (10) Calendar Days of receipt of a written request from ~~the other~~[another](#) Party, use Reasonable Efforts to destroy, erase, or delete (with such destruction, erasure, and deletion certified in writing to the other [Party/Parties](#)) or return to ~~the other~~[another](#) Party, without retaining copies thereof, any and all written or electronic Confidential Information received from the other Party.
- 22.1.9 Remedies.** The Parties agree that monetary damages would be inadequate to compensate a Party for ~~the other~~[another](#) Party's Breach of its obligations under this Article 22. Each Party accordingly agrees that the other [Party/Parties](#) shall be entitled to equitable relief, by way of injunction or otherwise, if the first Party Breaches or threatens to Breach its obligations under this Article 22, which equitable relief shall be granted without bond or proof of damages, and the receiving Party shall not plead in defense that there would be an adequate remedy at law. Such remedy shall not be deemed an exclusive remedy for the Breach of this Article 22, but shall be in addition to all other remedies available at law or in equity. The Parties further acknowledge and agree that the covenants contained herein are necessary for the protection of legitimate business interests and are reasonable in scope. No Party, however, shall be liable for indirect, incidental, or consequential or punitive damages of any nature or kind resulting from or arising in connection with this Article 22.
- 22.1.10 Disclosure to FERC, its Staff, or a State.** Notwithstanding anything in this Article 22 to the contrary, and pursuant to 18 CFR section 1b.20, if FERC or its staff, during the course of an investigation or otherwise, requests information from one of the Parties that is otherwise required to be maintained in confidence pursuant to this [LGIA Agreement](#), the Party shall provide the requested information to FERC or its staff, within the time provided for in the request for information. In providing the information to FERC or its staff, the Party must, consistent with 18 CFR section 388.112, request that the information be treated as confidential and non-public by FERC and its staff and that the information be withheld from public disclosure. Parties are prohibited from notifying the other Party to this [LGIA Agreement](#) prior to the release of the Confidential Information to FERC or its staff. The Party shall notify the other [Party/Parties](#) to the [LGIA Agreement](#) when it is notified by FERC or its staff that a request to release Confidential Information has been received by FERC, at which time ~~either~~[any](#) of the Parties may respond before such information would be made public, pursuant to 18 CFR section 388.112. Requests from a state regulatory body conducting a confidential investigation shall be treated in a similar manner if consistent with the applicable state rules and regulations.

22.1.11 Subject to the exception in Article 22.1.10, ~~any information that a Party claims is competitively sensitive, commercial or financial information under this LGIA~~ (“Confidential Information”) shall not be disclosed by the other ~~Party~~Parties to any person not employed or retained by the other ~~Party~~Parties, except to the extent disclosure is (i) required by law; (ii) reasonably deemed by the disclosing Party to be required to be disclosed in connection with a dispute between or among the Parties, or the defense of litigation or dispute; (iii) otherwise permitted by consent of the other ~~Party~~Parties, such consent not to be unreasonably withheld; or (iv) necessary to fulfill its obligations under this ~~LGIA Agreement~~ or as a transmission service provider or a ~~Control Area operator~~Balancing Authority including disclosing the Confidential Information to an RTO or ISO or to a regional or national reliability organization. The Party asserting confidentiality shall notify the other Party in writing of the information it claims is confidential. Prior to any disclosures of ~~the other~~another Party’s Confidential Information under this subparagraph, or if any third party or Governmental Authority makes any request or demand for any of the information described in this subparagraph, the disclosing Party agrees to promptly notify the other Party in writing and agrees to assert confidentiality and cooperate with the other Party in seeking to protect the Confidential Information from public disclosure by confidentiality agreement, protective order or other reasonable measures.

Article 23. Environmental Releases

23.1 Each Party shall notify the other ~~Party~~Parties, first orally and then in writing, of the release of any Hazardous Substances, any asbestos or lead abatement activities, or any type of remediation activities related to the Large Generating Facility or the Interconnection Facilities, each of which may reasonably be expected to affect the other Party. The notifying Party shall: (i) provide the notice as soon as practicable, provided such ~~Party~~Parties makes a good faith effort to provide the notice no later than twenty-four hours after such Party becomes aware of the occurrence; and (ii) promptly furnish to the other ~~Party~~Parties copies of any publicly available reports filed with any Governmental Authorities addressing such events.

Article 24. Information Requirements

24.1 Information Acquisition. APS, on behalf of Transmission ~~Provider~~Owners, and Interconnection Customer shall submit specific information regarding the electrical characteristics of their respective facilities to each other as described below and in accordance with Applicable Reliability Standards.

24.2 Information Submission by APS, on behalf of Transmission ~~Provider~~Owners. The initial information submission by APS, on behalf of Transmission ~~Provider~~Owners, shall occur no later than one hundred eighty (180) Calendar Days prior to Trial Operation of a Project Phase and shall include Transmission System information necessary to allow Interconnection Customer to select equipment and meet any system protection and stability requirements, unless otherwise agreed to by the Parties. On a monthly basis APS, on behalf of Transmission ~~Provider~~Owners, shall provide Interconnection Customer and the CAISO a status report on the construction and installation of Transmission

~~Provider's~~Owners' Interconnection Facilities and Network Upgrades, including, but not limited to, the following information: (1) progress to date; (2) a description of the activities since the last report (3) a description of the action items for the next period; and (4) the delivery status of equipment ordered.

24.3 Updated Information Submission by Interconnection Customer. The updated information submission by Interconnection Customer, including manufacturer information, shall occur no later than one hundred eighty (180) Calendar Days prior to the Trial Operation of a Project Phase. Interconnection Customer shall submit a completed copy of the Large Generating Facility data requirements contained in Appendix 1 to the LGIP. It shall also include any additional updates to information provided to ~~Transmission Provider~~APS and CAISO for the Interconnection Feasibility and Interconnection Facilities Study, and the CAISO Phase II Interconnection Study, as applicable. Information in this submission shall be the most current Large Generating Facility design or expected performance data. Information submitted for stability models shall be compatible with ~~Transmission Provider~~APS's and the CAISO's standard models. If there is no compatible model, Interconnection Customer will work with a consultant mutually agreed to by the Parties to develop and supply a standard model and associated information.

If Interconnection Customer's data is materially different from what was originally provided to ~~Transmission Provider~~APS or the CAISO pursuant to the Interconnection Study ~~Agreement~~Agreements between ~~Transmission Provider~~APS or the CAISO and Interconnection Customer, then ~~Transmission Provider~~APS or the CAISO, as applicable, will conduct appropriate studies to determine the impact on ~~Transmission Provider~~the Transmission System based on the actual data submitted pursuant to this Article 24.3. The Interconnection Customer shall not begin Trial Operation of a Project Phase until such studies are completed and all other applicable requirements of this Agreement are satisfied.

If Interconnection Customer's data is materially different from what was originally provided to IID by the CAISO or by the Interconnection Customer pursuant to the Affected System Study Agreement, then IID also shall have the right, but not the obligation, to conduct any appropriate Affected System Study necessary to determine the impact on its non-JPP transmission facilities based on the actual data submitted pursuant to this Article 24.3. To the extent IID exercises this right, Interconnection Customer shall not begin Trial Operation of a Project Phase until such studies are completed and all other applicable requirements of this Agreement are satisfied.

24.4 Information Supplementation. Prior to ~~the~~Trial Operation ~~Date~~of a Project Phase, the Parties shall supplement their information submissions described above in this Article 24 with any and all "as-built" Large Generating Facility information or "as-tested" performance information that differs from the initial submissions or, alternatively, written confirmation that no such differences exist. The Interconnection Customer shall conduct tests on the Large Generating Facility as required by Good Utility Practice such as an open circuit "step voltage" test on the Large Generating Facility to verify proper operation of the Large Generating Facility's automatic voltage regulator.

Unless otherwise agreed, the test conditions shall include: (1) Large Generating Facility at synchronous speed; (2) automatic voltage regulator on and in voltage control mode; and (3) a five percent change in Large Generating Facility terminal voltage initiated by a change in the voltage regulators reference voltage. Interconnection Customer shall provide validated test recordings showing the responses of Large Generating Facility terminal and field voltages. In the event that direct recordings of these voltages is impractical, recordings of other voltages or currents that mirror the response of the Large Generating Facility's terminal or field voltage are acceptable if information necessary to translate these alternate quantities to actual Large Generating Facility terminal or field voltages is provided. Large Generating Facility testing shall be conducted and results provided to ~~Transmission Provider for each individual generating unit in a station~~ APS and the CAISO at the request of APS and the CAISO.

Subsequent to the Commercial Operation Date for a Project Phase, Interconnection Customer shall provide ~~Transmission Provider~~ APS and the CAISO any information changes due to equipment replacement, repair, or adjustment. APS, on behalf of Transmission Provider Owners, shall provide Interconnection Customer any information changes due to equipment replacement, repair or adjustment in the directly connected substation or any adjacent Transmission ~~Provider-owned~~ Owners' substation that may affect Interconnection Customer's Interconnection Facilities equipment ratings, protection or operating requirements. The Parties shall provide such information ~~no later than thirty (30) Calendar Days after the date of the equipment replacement, repair or adjustment, pursuant to Article 5.19.~~

Article 25. Information Access and Audit Rights

- 25.1 Information Access.** Each Party (the "disclosing Party") shall make available to the other Party Parties information that is in the possession of the disclosing Party and is necessary in order for the other Party Parties to: (i) verify the costs incurred by the disclosing Party for which ~~the other~~ another Party is responsible under this LGIA Agreement; and (ii) carry out its obligations and responsibilities under this LGIA Agreement. The Parties shall not use such information for purposes other than those set forth in this Article 25.1 and to enforce their rights under this LGIA Agreement. Nothing in this Article 25 shall obligate a Party to make available to another Party any third party information in its possession or control if making such third party information available would violate a Tariff or other legal restriction on the use or disclosure of such third party information.
- 25.2 Reporting of Non-Force Majeure Events.** Each Party (the "notifying Party") shall notify the other Party Parties when the notifying Party becomes aware of its inability to comply with the provisions of this LGIA Agreement for a reason other than a Force Majeure event. The Parties agree to cooperate with each other and provide necessary information regarding such inability to comply, including the date, duration, reason for the inability to comply, and corrective actions taken or planned to be taken with respect to such inability to comply. Notwithstanding the foregoing, notification, cooperation or information provided under this article shall not entitle the Party Parties receiving such notification to allege a cause for anticipatory breach of this LGIA Agreement.

25.3 Audit Rights. Subject to the requirements of confidentiality under Article 22 of this [LGIA Agreement](#), each Party shall have the right, during normal business hours, and upon prior reasonable notice to the other Party, to audit at its own expense the other Party's accounts and records pertaining to either [such](#) Party's performance or either [such](#) Party's satisfaction of obligations under this [LGIA Agreement](#). Such audit rights shall include audits of the other Party's costs [pertaining to such Party's performance or satisfaction of obligations owned to the other Party under this Agreement](#), calculation of invoiced amounts, ~~Transmission Provider~~[APS's and the CAISO's](#) efforts to allocate responsibility for the provision of reactive support to the Transmission System, ~~Transmission Provider~~[Owners' and the CAISO's](#) efforts to allocate responsibility for interruption or reduction of generation on the Transmission System, and each Party's actions in an Emergency Condition. Any audit authorized by this article shall be performed at the offices where such accounts and records are maintained and shall be limited to those portions of such accounts and records that relate to each [such](#) Party's performance and satisfaction of obligations under this [LGIA Agreement](#). Each [such](#) Party shall keep such accounts and records for a period equivalent to the audit rights periods described in Article 25.4. [Notwithstanding anything to the contrary in Article 25, each Party's rights to audit APS's, IID's, SDG&E's or the CAISO's accounts and records shall be subject to their respective Tariffs.](#)

25.4 Audit Rights Periods.

25.4.1 Audit Rights Period for Construction-Related Accounts and Records.

Accounts and records related to the design, engineering, procurement, and construction of Transmission ~~Provider's~~[Owners'](#) Interconnection Facilities and Network Upgrades shall be subject to audit for a period of twenty-four months following ~~Transmission Provider's issuance of a~~[issuance of final invoice](#)~~invoices~~ in accordance with Article 12.2.

25.4.2 Audit Rights Period for All Other Accounts and Records. Accounts and records related to either Party's performance or satisfaction of all obligations under this [LGIA Agreement](#) other than those described in Article 25.4.1 shall be subject to audit as follows: (i) for an audit relating to cost obligations, the applicable audit rights period shall be twenty-four months after the auditing Party's receipt of an invoice giving rise to such cost obligations; and (ii) for an audit relating to all other obligations, the applicable audit rights period shall be twenty-four months after the event for which the audit is sought.

25.5 Audit Results. If an audit by a Party determines that an overpayment or an underpayment has occurred, a notice of such overpayment or underpayment shall be given to the other ~~Party~~[Parties](#) together with those records from the audit which support such determination.

Article 26. Subcontractors

26.1 General. Nothing in this [LGIA Agreement](#) shall prevent a Party from utilizing the services of any subcontractor as it deems appropriate to perform its obligations under this [LGIA Agreement](#); provided, however, that each Party shall require its subcontractors to

comply with all applicable terms and conditions of this [LGIA Agreement](#) in providing such services and each Party shall remain primarily liable to the other Party for the performance of such subcontractor.

- 26.2 Responsibility of Principal.** The creation of any subcontract relationship shall not relieve the hiring Party of any of its obligations under this [LGIA Agreement](#). The hiring Party shall be fully responsible to the other [Party Parties](#) for the acts or omissions of any subcontractor the hiring Party hires as if no subcontract had been made; provided, however, that in no event shall Transmission [Provider Owners or the CAISO](#) be liable for the actions or inactions of Interconnection Customer or its subcontractors with respect to obligations of Interconnection Customer under Article 5 of this [LGIA Agreement](#). Any applicable obligation imposed by this [LGIA Agreement](#) upon the hiring Party shall be equally binding upon, and shall be construed as having application to, any subcontractor of such Party.
- 26.3 No Limitation by Insurance.** The obligations under this Article 26 will not be limited in any way by any limitation of subcontractor's insurance.

Article 27. Disputes

[Disputes between the Interconnection Customer, CAISO and/or SDG&E arising out of requirements of the CAISO Tariff shall be settled in accordance with the provisions of Article 13 of the CAISO Tariff, except that references to the CAISO Tariff in such Article 13 of the CAISO Tariff shall be read as references to this Agreement. Disputes between the Interconnection Customer and IID arising out of the Affected System Study Agreement or Affected System Construction and Operation Agreement shall be resolved in accordance with the provisions of Section 13.5 of the Generation Interconnection Procedures in IID's Tariff. All other disputes shall be resolved as follows:](#)

- 27.1 Submission.** In the event ~~either~~a Party has a dispute, or asserts a claim, that arises out of or in connection with this [LGIA Agreement](#) or its performance, such Party (the "disputing Party") shall provide the other [Party Parties](#) with written notice of the dispute or claim ("Notice of Dispute"). Such dispute or claim shall be referred to a designated senior representative of each Party for resolution on an informal basis as promptly as practicable after receipt of the Notice of Dispute by the other [Party Parties](#). In the event the designated representatives are unable to resolve the claim or dispute through unassisted or assisted negotiations within thirty (30) Calendar Days of the other [Party's Parties'](#) receipt of the Notice of Dispute, such claim or dispute may, upon mutual agreement of the Parties, be submitted to arbitration and resolved in accordance with the arbitration procedures set forth below. In the event the Parties do not agree to submit such claim or dispute to arbitration, ~~each~~any Party may exercise whatever rights and remedies it may have in equity or at law consistent with the terms of this [LGIA Agreement](#).
- 27.2 External Arbitration Procedures.** Any arbitration initiated under this [LGIA Agreement](#) shall be conducted before a single neutral arbitrator appointed by the Parties. ~~If the Parties fail to agree upon a single arbitrator within ten (10) Calendar Days of the submission of the dispute to arbitration, each Party shall choose one arbitrator who shall sit on a three-member arbitration panel. The two arbitrators so chosen shall within~~

~~twenty (20) Calendar Days select a third arbitrator to chair the arbitration panel. In either case, the arbitrators, or in the absence of such appointment, by selection by the American Arbitration Association. The arbitrator~~ shall be knowledgeable in electric utility matters, including electric transmission and bulk power issues, and shall not have any current or past substantial business or financial relationships with any party to the arbitration (except prior arbitration). The arbitrator(s) shall provide each of the Parties an opportunity to be heard and, except as otherwise provided herein, shall conduct the arbitration in accordance with the Commercial Arbitration Rules of the American Arbitration Association ("Arbitration Rules") and any applicable FERC regulations ~~or RTO rules~~; provided, however, in the event of a conflict between the Arbitration Rules and the terms of this Article 27, the terms of this Article 27 shall prevail.

27.3 Arbitration Decisions. Unless otherwise agreed by the Parties, the arbitrator(s) shall render a decision within ninety (90) Calendar Days of appointment and shall notify the Parties in writing of such decision and the reasons therefor. The arbitrator(s) shall be authorized only to interpret and apply the provisions of this [LGIA Agreement](#) and shall have no power to modify or change any provision of this Agreement in any manner. The decision of the arbitrator(s) shall be final and binding upon the Parties, and judgment on the award may be entered in any court having jurisdiction. The decision of the arbitrator(s) may be appealed solely on the grounds that the conduct of the arbitrator(s), or the decision itself, violated the standards set forth in the Federal Arbitration Act or the Administrative Dispute Resolution Act. The final decision of the arbitrator must also be filed with FERC if it affects jurisdictional rates, terms and conditions of service, Interconnection Facilities, or Network Upgrades.

27.4 Costs. Each Party shall be responsible for its own costs incurred during the arbitration process and for ~~the following costs, if applicable: (1) its per capita share of the cost of the arbitrator chosen by the Party to sit on the three member panel and one half of the cost of the third arbitrator chosen; or (2) one half the cost of the single arbitrator jointly chosen by the Parties.~~

Article 28. Representations, Warranties, and Covenants

28.1 General. Each Party makes the following representations, warranties and covenants:

28.1.1 Good Standing. Such Party is duly organized, validly existing and in good standing under the laws of the state in which it is organized, formed, or incorporated, as applicable; that it is qualified to do business in the state or states in which the Large Generating Facility, Interconnection Facilities and Network Upgrades owned by such Party, as applicable, are located; and that it has the corporate power and authority to own its properties, to carry on its business as now being conducted and to enter into this [LGIA Agreement](#) and carry out the transactions contemplated hereby and perform and carry out all covenants and obligations on its part to be performed under and pursuant to this [LGIA Agreement](#).

28.1.2 Authority. Such Party has the right, power and authority to enter into this [LGIA Agreement](#), to become a Party hereto and to perform its obligations

hereunder. This [LGIA Agreement](#) is a legal, valid and binding obligation of such Party, enforceable against such Party in accordance with its terms, except as the enforceability thereof may be limited by applicable bankruptcy, insolvency, reorganization or other similar laws affecting creditors' rights generally and by general equitable principles (regardless of whether enforceability is sought in a proceeding in equity or at law).

28.1.3 No Conflict. The execution, delivery and performance of this [LGIA Agreement](#) does not violate or conflict with the organizational or formation documents, or bylaws or operating agreement, of such Party, or any judgment, license, permit, order, material agreement or instrument applicable to or binding upon such Party or any of its assets.

28.1.4 Consent and Approval. Such Party has sought or obtained, or, in accordance with this [LGIA Agreement](#) will seek or obtain, each consent, approval, authorization, order, or acceptance by any Governmental Authority in connection with the execution, delivery and performance of this [LGIA Agreement](#), and it will provide to any Governmental Authority notice of any actions under this [LGIA Agreement](#) that are required by Applicable Laws and Regulations.

Article 29. Joint Operating Committee

29.1 Joint Operating Committee. ~~Except in APS, on behalf of the case of ISOs and RTOs,~~ Transmission ~~Provider~~ [Owners](#), shall constitute a Joint Operating Committee to coordinate operating and technical considerations of Interconnection Service. At least six (6) months prior to the expected Initial Synchronization Date, [APS and](#) Interconnection Customer ~~and Transmission Provider~~ shall ~~each~~ appoint one representative and one alternate to the Joint Operating Committee. ~~Each APS and~~ Interconnection Customer shall notify ~~Transmission Provider~~ [each other](#) of its appointment in writing. Such appointments may be changed at any time by similar notice. The Joint Operating Committee shall meet as necessary, but not less than once each calendar year, to carry out the duties set forth herein. The Joint Operating Committee shall hold a meeting at the request of ~~either any~~ Party, at a time and place agreed upon by the representatives [of the Joint Operating Committee](#). The Joint Operating Committee shall perform all of its duties consistent with the provisions of this [LGIA Agreement](#). Each Party shall cooperate in providing to the Joint Operating Committee all information required in the performance of the Joint Operating Committee's duties. All decisions and agreements, if any, made by the Joint Operating Committee, shall be evidenced in writing. The duties of the Joint Operating Committee shall include the following:

29.1.1 Establish data requirements and operating record requirements.

29.1.2 Review the requirements, standards, and procedures for data acquisition equipment, protective equipment, and any other equipment or software.

29.1.3 Annually review the one (1) year forecast of maintenance and planned outage schedules of Transmission [Provider's Owners'](#) and Interconnection Customer's facilities at the Point of Interconnection.

- 29.1.4** Coordinate the scheduling of maintenance and planned outages on the Interconnection Facilities, the Large Generating Facility and other facilities that impact the normal operation of the interconnection of the Large Generating Facility to the Transmission System.
- 29.1.5** Ensure that information is being provided by each Party regarding equipment availability.
- 29.1.6** Perform such other duties as may be conferred upon it by mutual agreement of the Parties.

Article 30. Miscellaneous

- 30.1 Binding Effect.** This [LGIA Agreement](#) and the rights and obligations hereof, shall be binding upon and shall inure to the benefit of the successors and assigns of the Parties hereto.
- 30.2 Conflicts.** In the event of a conflict between the body of this [LGIA Agreement](#) and any attachment, appendices or exhibits hereto, the terms and provisions of the body of this [LGIA Agreement](#) shall prevail and be deemed the final intent of the Parties.
- 30.3 Rules of Interpretation.** This [LGIA Agreement](#), unless a clear contrary intention appears, shall be construed and interpreted as follows: (1) the singular number includes the plural number and vice versa; (2) reference to any person includes such person's successors and assigns but, in the case of a Party, only if such successors and assigns are permitted by this [LGIA Agreement](#), and reference to a person in a particular capacity excludes such person in any other capacity or individually; (3) reference to any agreement (including this [LGIA Agreement](#)), document, instrument or tariff means such agreement, document, instrument, or tariff as amended or modified and in effect from time to time in accordance with the terms thereof and, if applicable, the terms hereof; (4) reference to any Applicable Laws and Regulations means such Applicable Laws and Regulations as amended, modified, codified, or reenacted, in whole or in part, and in effect from time to time, including, if applicable, rules and regulations promulgated thereunder; (5) unless expressly stated otherwise, reference to any Article, Section or Appendix means such Article of this [LGIA Agreement](#) or such Appendix to this [LGIA Agreement](#), or such Section to the [LGIP applicable Large Generator Interconnection Procedures](#) or such Appendix to the [LGIP applicable Large Generator Interconnection Procedures](#), as the case may be; (6) "hereunder", "hereof", "herein", "hereto" and words of similar import shall be deemed references to this [LGIA Agreement](#) as a whole and not to any particular Article or other provision hereof or thereof; (7) "including" (and with correlative meaning "include") means including without limiting the generality of any description preceding such term; and (8) relative to the determination of any period of time, "from" means "from and including", "to" means "to but excluding" and "through" means "through and including".
- 30.4 Entire Agreement.** This [LGIA Agreement](#), including all Appendices and Schedules attached hereto, constitutes the entire agreement ~~between~~[among all of](#) the Parties with

reference to the subject matter hereof, and supersedes all prior and contemporaneous understandings or agreements, oral or written, ~~between~~among the Parties with respect to the subject matter of this [LGIA Agreement](#). There are no other agreements (other than the Affected System Study Agreement and Affected System Construction and Operation Agreement), representations, warranties, or covenants which constitute any part of the consideration for, or any condition to, ~~either~~any Party's compliance with its obligations under this [LGIA Agreement](#).

30.5 No Third Party Beneficiaries. This [LGIA Agreement](#) is not intended to and does not create rights, remedies, or benefits of any character whatsoever in favor of any persons, corporations, associations, or entities other than the Parties, and the obligations herein assumed are solely for the use and benefit of the Parties, their successors in interest and, where permitted, their assigns.

30.6 Waiver. The failure of a Party to this [LGIA Agreement](#) to insist, on any occasion, upon strict performance of any provision of this [LGIA Agreement](#) will not be considered a waiver of any obligation, right, or duty of, or imposed upon, such Party.

Any waiver at any time by either Party of its rights with respect to this [LGIA Agreement](#) shall not be deemed a continuing waiver or a waiver with respect to any other failure to comply with any other obligation, right, duty of this [LGIA Agreement](#). Termination or Default of this [LGIA Agreement](#) for any reason by Interconnection Customer shall not constitute a waiver of Interconnection Customer's legal rights to obtain an interconnection from Transmission ~~Provider~~Owner. Any waiver of this [LGIA Agreement](#) shall, if requested, be provided in writing.

30.7 Headings. The descriptive headings of the various Articles of this [LGIA Agreement](#) have been inserted for convenience of reference only and are of no significance in the interpretation or construction of this [LGIA Agreement](#).

30.8 Multiple Counterparts. This [LGIA Agreement](#) may be executed in two or more counterparts, each of which is deemed an original but all constitute one and the same instrument.

30.9 Amendment. The Parties may by mutual agreement amend this [LGIA Agreement](#) by a written instrument duly executed by ~~the Parties~~all the Parties. Such amendment shall become effective and a part of this Agreement upon satisfaction of all Applicable Laws and Regulations.

30.10 Modification by the Parties. The Parties may by mutual agreement amend the Appendices to this [LGIA Agreement](#) by a written instrument duly executed by the Parties. Such amendment shall become effective and a part of this [LGIA Agreement](#) upon satisfaction of all Applicable Laws and Regulations.

30.11 Reservation of Rights. FERC-jurisdictional Transmission ~~Provider~~Owners and the [CAISO](#) shall have the right to make a unilateral filing with FERC to modify this [LGIA Agreement](#) with respect to any rates, terms and conditions, charges, classifications of service, rule or regulation under section 205 or any other applicable provision of the

Federal Power Act and FERC's rules and regulations thereunder, and Interconnection Customer shall have the right to make a unilateral filing with FERC to modify this ~~LGIA Agreement~~ pursuant to section 206 or any other applicable provision of the Federal Power Act and FERC's rules and regulations thereunder; provided that ~~each~~another Party shall have the right to protest any such filing by the other Party and to participate fully in any proceeding before FERC in which such modifications may be considered. Nothing in this ~~LGIA Agreement~~ shall limit the rights of the Parties or of FERC under sections 205 or 206 of the Federal Power Act and FERC's rules and regulations thereunder, except to the extent that the Parties otherwise mutually agree as provided herein.

Notwithstanding the foregoing, IID shall not be subject, without its mutual consent, to a modification of its rights and obligations under this Agreement through a unilateral filing by another Party with FERC and, as applied to IID, the Effective Date of a modified Agreement shall not commence until the modified Agreement is actually executed by IID, either voluntarily or pursuant to a lawful order issued by FERC in accordance with Sections 210 and 212 of the Federal Power Act.

30.12 No Partnership. This ~~LGIA Agreement~~ shall not be interpreted or construed to create an association, joint venture, agency relationship, or partnership ~~between~~among the Parties or to impose any partnership obligation or partnership liability upon ~~either~~any Party. ~~Neither~~No Party shall have any right, power or authority to enter into any agreement or undertaking for, or act on behalf of, or to act as or be an agent or representative of, or to otherwise bind, ~~the other~~another Party.

30.13 Joint and Several Obligations. Except as otherwise provided in this Agreement, the obligations of each Transmission Owner, the CAISO and the Interconnection Customer are several, and are neither joint nor joint and several.

[REMAINDER OF PAGE INTENTIONALLY LEFT BLANK]

IN WITNESS WHEREOF, the Parties have executed this LGIA Agreement in ~~duplicate~~multiple originals, each of which shall constitute and be an original effective Agreement ~~between~~among the Parties.

~~[Insert name of Transmission Provider or Transmission Owner, if applicable]~~

Arizona Public Service Company Imperial Irrigation District

By: _____ By: _____

Name: _____ Name: _____

Title: _____ Title: _____

Date: _____ Date: _____

~~[Insert name of Interconnection Customer]~~

San Diego Gas & Electric Company California Independent System Operator Corporation

By: _____ By: _____

Name: _____ Name: _____

Title: _____ Title: _____

Date: _____ Date: _____

Agua Caliente Solar, LLC North Gila River Development, LLC

By: _____ By: _____

Name: _____ Name: _____

Title: _____ Title: _____

Date: _____ Date: _____

Appendices

Appendix A-~~1~~ to LGIA

Interconnection Facilities, JPP Network Upgrades, and Distribution Upgrades for Phase A of the Interconnection Project

~~1. Interconnection Facilities:~~

~~(a) [insert Interconnection Customer's Interconnection Facilities]:~~

~~(b) [insert Participating TO's Interconnection Facilities]:~~

~~2. Network Upgrades:~~

~~(a) [insert Stand Alone Network Upgrades]:~~

~~(b) [insert Other Network Upgrades]:~~

~~(i) [insert Participating TO's Reliability Network Upgrades]~~

~~(ii) [insert Participating TO's Delivery Network Upgrades]~~

~~3. Distribution Upgrades:~~

The Generating Facility will have a total rated capacity of 500 MW based on both Phase A and Phase B achieving Commercial Operation. This Appendix A-1 addresses Phase A of the Generating Facility and Appendix A-2 addresses Phase B of the Generating Facility.

1. Phase A of the Generating Facility Description:

Phase A of the Generating Facility is located on private land and consists of a photovoltaic solar field, inverters, a medium voltage collection system, an operations and maintenance building, a 34.5kV/500kV substation and various other facilities. Phase A of the Generating Facility will consist of no more than 290 MW (net) of solar photovoltaic units installed at the site.

The Interconnection Customer Interconnection Facilities include a new substation which will contain two (2) 34.5kV/500kV step-up transformers ("SUTs"). The SUTs are combined through a common high voltage bus that is connected to one single 500 kV interconnection line. Phase A of the Generating Facility is connected to the Transmission Owners' 500kV switchyard ("Switchyard") via the single 500kV interconnection line. The substation is located in close proximity to the Switchyard.

2. Point of Interconnection:

The Point of Interconnection for Phase A of the Generating Facility is the Switchyard. See Appendix C – Diagram.

3. Power Injection Limitation at the Point of Interconnection:

The maximum allowable injection of power into the Switchyard at the Point of Interconnection for Phase A of the Generating Facility shall be 290 MW.

4. Point of Change of Ownership:

The Point of Change of Ownership demarcation point of the high voltage conductors and static wires will be the first designed dead end structure outside of the Switchyard fence. The Point of Change of Ownership will be at the line jumper connection point on the Transmission Owners' dead-ended conductor. Interconnection Customer will provide, per APS specifications, required materials, including foundations, steel structures, insulators, attachment hardware and dead-end connectors to install and terminate conductors at this structure from Switchyard. APS will supply and install conductors to this point of attachment. Interconnection Customer will provide and install materials, including insulators, attachment hardware, conductors, dead-end connectors, and jumper connections, from the Generating Facility substation to the termination point on the dead end structure. See Appendix C – Diagram.

If overhead communication cable is utilized, the interconnection and ownership demarcation point will be a splice point located on the first designed dead-end structure for the high voltage conductor outside of the Switchyard fence. Interconnection Customer will provide required materials for attachment of cable to structures to this point from the Switchyard. APS will provide communication cable to this point. Interconnection Customer will be responsible for providing materials and connection to APS termination at this location.

If underground communication cable is utilized, the interconnection and ownership demarcation point will be a manhole located outside of the Switchyard fence. APS will provide manhole and other materials required to install cable from the Switchyard. Interconnection Customer will be responsible for providing materials and connection to APS termination at this location.

5. Interconnection Facilities:

(a) Interconnection Customer's Interconnection Facilities

The Interconnection Customer's Interconnection Facilities consists of a 34.5/500kV Generating Facility substation, support structures, including the two sided dead end structure, and a generation tie line from the Generating Facility substation to the Point of Change of Ownership with the Transmission Owner's Interconnection Facilities. The Interconnection Customer's Interconnection Facilities also includes all metering equipment required to comply with the CAISO Tariff.

The following is an equipment list from the Interconnection Customer's Interconnection Facilities:

2 – 34.5kV/500kV step up transformers
Revenue meter
Shunt capacitors
Transmission structure at ownership change

(b) Transmission Owners' Interconnection Facilities

The Transmission Owners' Interconnection Facilities consist of the facilities between the Point of Change of Ownership and Point of Interconnection in the Switchyard. This consists of one 500 kV disconnect switch, and a span of 500kV conductor. The protection equipment for Phase A of the Interconnection Project is also included in Transmission Owners' Interconnection Facilities as is the metering equipment for the interconnection.

The following is an equipment list comprising the Transmission Owners' Interconnection Facilities:

Intertie meter

1 500kV, 3000A, Vertical Break Switch

Conductor

Relays

6. JPP Network Upgrades:

(a) Switchyard

APS will design and construct the new 500kV Switchyard. The Switchyard will be designed as a breaker-and-a-half configuration to accommodate future plans of the Transmission Owners and potential future third-party generation developers. Initially, three 500kV breakers and supporting bus work and structures will be built to accommodate the line terminations from (i) Hassayampa, (ii) North Gila and (iii) the Generating Facility. This initial phase of the Switchyard will include 500kV bus work and disconnect switches to limit outages for future installations.

The Switchyard will also include a control enclosure for the housing of the critical protective relaying and the Supervisory Control and Data Acquisition (SCADA) system. The control room building will include sufficient battery capacity to reliably operate the Switchyard as part of the interconnected Transmission System. Redundant communication will be provided by a new 100-foot microwave tower constructed to support sufficient dishes and antenna to provide reliable integration of the Generating Facility into the APS communications network. No fiber optic lines are planned for Phase A of the Interconnection Project.

The Switchyard site will be secured with a minimum 7-foot tall, chain link metal-fabric security fence with 1-foot barbed wire or razor wire on top.

The following is an equipment list from the Switchyard portion of the JPP Network Upgrades:

Breakers - 3 500kV, 3000A, 63kA

Switches - 10 500kV, 3000A, Vertical Break

1 500kV 3000A, Vertical Reach

*Current Transformers (CTs) - 3 500kV, Extended Range Metering Accuracy 1500/5A
CC Voltage Transformers (11)*

A fourth breaker will be required when the Switchyard is converted from a ring bus alignment to a breaker and one half arrangement. The timing for this change will be driven by a fifth termination into the Switchyard.

(b) Transmission Line

The transmission interconnection will be a loop-in of the Switchyard to the existing Hassayampa – North Gila #1 500 kV line with the end points being new turning structures located within the existing 500kV line rights-of-way and the dead-end structures located within the Switchyard.

The following is an equipment/material list from the transmission line portion of the JPP Network Upgrades:

2 500kV Lattice Tower structures
Conductor

7. Stand-Alone JPP Network Upgrades: None

8. Transmission Owners' Interconnection Facilities and JPP Network Upgrade Cost Summary:

Cost Estimate (2010 dollars)

<u>Element</u>	<u>Cost</u>	<u>Transmission Owner Share</u>		
		<u>APS</u>	<u>IID</u>	<u>SDG&E</u>
<u>Transmission Owners' Interconnection Facilities</u>				
<u>500kV conductor tie line</u>	<u>611,000</u>	<u>0</u>	<u>0</u>	<u>0</u>
<u>Disconnect Switches</u>	<u>150,000</u>	<u>0</u>	<u>0</u>	<u>0</u>
<u>Protection Equipment</u>	<u>400,000</u>	<u>0</u>	<u>0</u>	<u>0</u>
<u>Contingency</u>	<u>232,000</u>	<u>0</u>	<u>0</u>	<u>0</u>
<u>1) Subtotal</u>	<u>1,393,000</u>	<u>0</u>	<u>0</u>	<u>0</u>
<u>JPP Network Upgrades</u>				
<u>Transmission</u>	<u>1,985,000</u>	<u>218,350</u>	<u>253,683</u>	<u>1,512,967</u>
<u>Switchyard</u>	<u>14,700,000</u>	<u>1,617,000</u>	<u>1,878,660</u>	<u>11,204,340</u>
<u>Telecommunications</u>	<u>75,000</u>	<u>8,250</u>	<u>9,585</u>	<u>57,165</u>
<u>Relay changes at Hassayampa</u>	<u>136,000</u>	<u>14,960</u>	<u>17,381</u>	<u>103,659</u>
<u>Relay changes at North Gila</u>	<u>136,000</u>	<u>14,960</u>	<u>17,381</u>	<u>103,659</u>
<u>Deferred breaker</u>	<u>810,000</u>	<u>89,100</u>	<u>103,518</u>	<u>617,382</u>
<u>Contingency</u>	<u>3,568,000</u>	<u>392,480</u>	<u>455,990</u>	<u>2,719,530</u>
<u>2) Subtotal JPP Network Upgrades</u>	<u>21,410,000</u>	<u>2,355,100</u>	<u>2,736,198</u>	<u>16,318,702</u>
<u>3) Interconnection Project Cost (for cash flow and financial security) (lines 1 & 2)</u>	<u>22,803,000</u>	<u>2,508,330</u>	<u>2,914,223</u>	<u>17,380,447</u>
<u>4) Interconnection Customer Contributions to Network Upgrades (real estate, environmental, and rough grading)</u>	<u>1,173,000</u>	<u>129,030</u>	<u>149,909</u>	<u>894,060</u>
<u>5) Total Network Upgrades (for reimbursement to Agua Caliente Solar, LLC) (lines 2 & 4)</u>	<u>22,583,000</u>	<u>2,484,130</u>	<u>2,886,107</u>	<u>17,212,763</u>

9. Estimate of Monthly Incurred Costs for the Transmission Owners' Interconnection Facilities and JPP Network Upgrades:

An estimate of the monthly incurred costs is shown below.

<u>Month</u>	<u>Estimated Cost by Month</u>
<u>Through April 2010</u>	<u>\$240,168</u>
<u>May 2010</u>	<u>\$0</u>
<u>June 2010</u>	<u>\$0</u>
<u>July 2010</u>	<u>\$486,924</u>
<u>August 2010</u>	<u>\$0</u>
<u>September 2010</u>	<u>\$0</u>
<u>October 2010</u>	<u>\$863,108</u>
<u>November 2010</u>	<u>\$863,108</u>
<u>December 2010</u>	<u>\$863,108</u>
<u>January 2011</u>	<u>\$5,305,720</u>
<u>February 2011</u>	<u>\$5,305,720</u>
<u>March 2011</u>	<u>\$5,305,720</u>
<u>April 2011</u>	<u>\$337,376</u>
<u>May 2011</u>	<u>\$337,376</u>
<u>June 2011</u>	<u>\$337,376</u>
<u>July 2011</u>	<u>\$348,120</u>
<u>August 2011</u>	<u>\$348,120</u>
<u>September 2011</u>	<u>\$348,120</u>
<u>October 2011</u>	<u>\$119,108</u>
<u>November 2011</u>	<u>\$119,108</u>
<u>December 2011</u>	<u>\$119,108</u>
<u>January 2012</u>	<u>\$1,155,672</u>
<u>Total</u>	<u>\$22,803,000</u>

10. Invoicing and JPP Network Upgrade Repayment:

Invoices issued by APS on behalf of the Transmission Owners pursuant to Articles 12.1 and 12.2 of this Agreement for Phase A of the Generating Facility shall include the cumulative balance invoiced to date for the JPP Network Upgrades (including the actual costs for Network Upgrades incurred under the E&P Agreement) and the allocation of such balance to the Ownership Interests.

Within thirty (30) Calendar Days of the Commercial Operation Date for a Project Phase, APS, on behalf of the Transmission Owners, shall provide the Parties with a statement which indicates the Ownership Share of each of the Transmission Owners in the cost of the Network Upgrades which are to be repaid in accordance with the provisions of Article 11.4.2 of this Agreement.

- (a) SDG&E Share: Interconnection Customer and SDG&E have agreed that SDG&E shall make the repayment provided for in Article 11.4.2 of this Agreement by making a cash payment to Agua Caliente Solar, LLC within sixty (60) Calendar Days of the Commercial Operation Date of each Project Phase.
- (b) APS Share: APS shall make the repayment provided for in Article 11.4.1 of this Agreement to Agua Caliente Solar, LLC in accordance with the terms of this Agreement.
- (c) IID Share: IID shall make the repayment provided for in Article 11.4.3 of this Agreement to Agua Caliente Solar, LLC in accordance with the terms of this Agreement.

11. Distribution Upgrades: NONE

12. Maintenance, Repair, and Replacement Charges:

The Interconnection Customer shall be responsible for actual costs incurred by APS, on behalf of the Transmission Owners, applicable to the maintenance, repair and replacement of the Transmission Owners' Interconnection Facilities, including but not limited to: the 500 kV disconnect switches, protection equipment for the Interconnection Customer's Interconnection Facilities, metering including CTs and PTs and communications equipment and all associated equipment (see Appendix C, Diagram). A good faith non-binding estimate of annual cost, for budgetary purposes only, is:

Estimate = \$ 1,000 per year

\$1,000 annually covers:

- Two inspections per year
- Relay maintenance (estimated at every 4-6 years)
- Disconnect switch maintenance (estimated at every 4-6 years)

Additional actual costs will be charged for:

- Emergency maintenance and repair work
- Replacement of failed or failing equipment

13. Transition from E&P Agreement:

The Parties recognize that some design and long lead-time procurement work for the interconnection of the Large Generating Facility to the JPP was done pursuant to the E&P Agreement entered into by APS, on behalf of the Transmission Owners, and the Interconnection Customer. In order to provide for a smooth transition between work done under the E&P Agreement and this Agreement, the Parties agree.:

- (a) Accounting Transition. APS, on behalf of the Transmission Owners, shall calculate whether the Interconnection Customer has paid more or less than it owes under the terms of the E&P Agreement as of the Effective Date of this Agreement. If the Interconnection Customer paid more than it owes, APS, on behalf of the Transmission Owners, shall apply a credit to reduce the amount of the payments required under Article 12.1 of this Agreement for the Transmission Owners' Interconnection Facilities and JPP Network Upgrades. If the Interconnection Customer

has paid less than it owes, the Interconnection Customer shall pay the amount due as if it were incurred for engineering and procurement work conducted pursuant to this Agreement, in accordance with Article 12.1 of this Agreement, for the Transmission Owners' Interconnection Facilities and JPP Network Upgrades.

(b) Estimate of Total Interconnection Customer Payments. In accordance with the Milestone Schedule in Appendix B-1, APS, on behalf of the Transmission Owners, shall provide an estimate of the total amount the Interconnection Customer paid under the E&P Agreement as of the Effective Date of this Agreement. This estimate shall be applied as a credit toward the amount of financial security due from the Interconnection Customer pursuant to Article 11.5 of this Agreement and Section 15 of this Appendix A-1 for the Transmission Owners' Interconnection Facilities and JPP Network Upgrades.

(c) Letter of Credit. If the Interconnection Customer has posted a letter of credit or other financial security under the terms of the E&P Agreement, the letter of credit or other financial security shall be returned to Interconnection Customer as of the date the Interconnection Customer posts all of the financial security required in accordance with the terms of Article 11.5 of this Agreement and Section 14 of this Appendix A-1 for the Transmission Owners' Interconnection Facilities and JPP Network Upgrades.

14. Provision of Security:

(a) Initial Estimate of Financial Security to be Posted: The amount available to be drawn under any credit support for the Transmission Owners' Interconnection Facilities and JPP Network Upgrades required to interconnect Phase A of the Generating Facility shall be:

<u>APS Share (11.00%)</u>	<u>\$2,508,330</u>
<u>IID Share (12.78%)</u>	<u>\$2,914,223</u>
<u>Subtotal of APS and IID shares (23.78%)</u>	<u>\$5,422,553</u>
<u>SDG&E Share (76.22%)</u>	<u>\$17,380,447</u>
<u>TOTAL (100%)</u>	<u>\$22,803,000</u>

(b) Adjustment for Amounts Paid under E&P Agreement: The initial estimate of the financial security provided in Section 14(a) of this Appendix A-1 shall be reduced by each of the Transmission Owner's proportional shares of the estimated total Interconnection Customer payments made under the E&P Agreement. When APS, on behalf of the Transmission Owners, provides an estimate of the Interconnection Customer's total payments under the E&P Agreement pursuant to Section 13(b) of this Appendix A-1, it shall provide to the Interconnection Customer and the other Transmission Owners an adjusted estimate of the financial security to be posted.

(c) Posting: The Interconnection Customer shall provide financial security for the Transmission Owners' Interconnection Facilities and JPP Network Upgrades no later than the milestone date specified in Appendix B-1 in accordance with Article 11.5 of this Agreement. With respect to the financial security for the APS and IID shares, Interconnection Customer shall post with APS, on behalf of APS and IID, the adjusted amount for both the APS and IID shares provided pursuant to Section 14(b) of this Appendix A-1 in the form of one security instrument.

With respect to the Interconnection Financial Security for SDG&E, SDG&E already holds Interconnection Financial Security for Phase A of the Generating Facility pursuant to the CAISO Tariff. As of the date of signing of this Agreement, this security consists of two irrevocable letters of credit for the benefit of Agua Caliente Solar LLC. One of these letters, in the amount of \$5.8 million, has been posted to cover a portion of the Interconnection Customer's share of Network Upgrades. The other, in the amount of \$228,600 has been posted to cover a portion of the Transmission Owners' Interconnection Facilities. The letter of credit for the larger amount currently posted will terminate in accordance with its terms as of October 30, 2010, and the letter of credit for the smaller amount will terminate in accordance with its terms on October 30, 2010. Pursuant to the terms of the CAISO Tariff, these letters of credit must be replaced before they terminate; failure to do so shall provide grounds for termination of this Agreement as provided in Articles 2.3 and 11.5 of this Agreement.

It is possible that the amount of Interconnection Financial Security which the Interconnection Customer was previously required to post may be reduced by order of FERC as a result of litigation pending in Docket No. EL10-15. Regardless of any developments in that proceeding, Interconnection Customer will post the full amount of financial security as required by this Agreement for Phase A of the Generating Facility.

Under this Agreement the total amount the Interconnection Customer shall post no later than the milestone due date specified in Appendix B-1 shall be the adjusted amount for the SDG&E share provided pursuant to Section 14(b) of this Appendix A-1. If Interconnection Financial Security is to be provided before October 31, 2010, SDG&E agrees that the initial Interconnection Financial Security posted with SDG&E shall be replaced with new Interconnection Financial Security posted in accordance with the terms of this Agreement for the total adjusted amount for the SDG&E share provided pursuant to Section 14(b) of this Appendix A-1. SDG&E further agrees that it shall return the original Interconnection Financial Security and shall take no action to enforce its security rights, if any, under the existing Interconnection Financial Security once Interconnection Customer has posted new Interconnection Financial Security in accordance with the terms of this Agreement.

The Parties agree that the Interconnection Customer shall be allowed to make substitutions of the security posted under this Agreement so long as the new security posted is reasonably acceptable to the Transmission Owners, as provided for in Article 11.5 of this Agreement, and in the amount required by this Agreement.

(d) Reduction of Amount of Security: Interconnection Customer shall make arrangements for financial security that provide for periodic reduction of the amount of the financial security upon receipt of instructions from APS, acting on behalf of the Transmission Owners. APS, on behalf of the Transmission Owners, shall provide periodic notices of reductions in the amount of the financial security required to be held to the financial institution(s) the Interconnection Customer selects to hold the financial security. APS shall provide such notices to the financial institution holding the security for the APS and IID shares in accordance with the arrangements made by the Interconnection Customer with the financial institution(s), provided, however, that the procedures for providing notice are reasonably acceptable to APS. APS shall also provide notice to SDG&E and IID. Unless otherwise agreed by APS and the Interconnection Customer, APS shall provide notice monthly as payments are made in accordance with Article 12.1 and the financial security shall be reduced proportionately on a dollar-for-dollar by the payments made under this Agreement.

SDG&E agrees that within five (5) Calendar Days of receiving notice of a reduction in the amount of the security pursuant to this section, it shall inform the financial institution that holds the Interconnection Financial Security of the reduction in the amount of the security.

(e) **Increases to Security Required Due to Change of Cost Estimates.** In the event that APS, on behalf of the Transmission Owners, finds that the cost estimate for Transmission Owner Interconnection Facilities and JPP Network Upgrades provided in this Appendix A-1 has increased, APS, on behalf of the Transmission Owners, shall have the option of (1) offsetting any reduction in the amount of security under Section 14(d) of this Appendix A-1 with the increase in the cost estimate, or (2) notifying Interconnection Customer of the required increase in its financial security to conform to the increased cost estimate.

(f) **Enforcement of Security for Transmission Owners' Interconnection Facilities and JPP Network Upgrades:** In the event that this Agreement is terminated in accordance with Article 2.3 and APS, on behalf of Transmission Owners, is required to determine the cost responsibility of the Interconnection Customer in accordance with Article 2.4 for Transmission Owners' Interconnection Facilities and JPP Network Upgrades set forth in this Appendix A-1, the Parties agree that in addition to following the procedures set forth elsewhere in this Agreement, the Transmission Owners shall proceed as follows:

(1) Subject to review and approval by all Transmission Owners, APS shall provide a statement indicating the total cost responsibility of the Interconnection Customer to all Transmission Owners and the allocation of this cost responsibility by Ownership Share ("Statement of Cost Responsibility"). This Statement of Cost Responsibility shall be accompanied by a detailed report which shows how the cost responsibility was determined, including information on all expenditures made on behalf of the Interconnection Customer, payments received, and bills outstanding.

(2) If the Interconnection Customer has cost responsibility, upon providing the Statement of Cost Responsibility and accompanying information, APS, on behalf of both APS and IID, shall enforce their financial security rights in proportion to the combined Ownership Interests of APS and IID.

(3) If the Interconnection Customer has cost responsibility, upon receipt of the Statement of Cost Responsibility and accompanying information, SDG&E shall enforce its financial security rights in proportion to the Ownership Interest of SDG&E. Within thirty Calendar Days of receipt of the Statement of Cost Responsibility, SDG&E shall provide the funds it receives by enforcing its financial security rights to APS.

(4) APS, acting on behalf of the Transmission Owners, shall use the funds provided by enforcing the financial security rights of the Transmission Owners to provide reimbursements and settle accounts proportionately in accordance with the Statement of Cost Responsibility and accompanying report.

15. Reporting Requirements:

Until the In-Service Date for the Transmission Owners' Interconnection Facilities and JPP Network Upgrades for Phase A of the Interconnection Project, Interconnection Customer and APS shall conduct a monthly meeting to coordinate the work related to the Transmission Owners' Interconnection Facilities and JPP Network Upgrades in this Appendix A-1. APS shall submit a monthly written report to the Interconnection Customer in advance of the meeting that provides the following information:

- (a) Progress report on activities;
- (b) Project schedule update; and
- (c) Spending report, including actual expenditures to date and forecasted expenditures in accordance with standard accounting practices.

16. Relationship of Agreement to CAISO Phase II Interconnection Study Report

The Parties acknowledge that this Appendix A-1 contains a list of Interconnection Facilities and JPP Network Upgrades and associated cost estimates that differs in some respects from the list of Interconnection Facilities and JPP Network Upgrades and associated cost estimates in the CAISO Phase II Interconnection Study report. The Parties agree to the descriptions of the Interconnection Facilities and JPP Network Upgrades and associated cost estimates in this Agreement notwithstanding any portions of the CAISO Phase II Interconnection Study report that are inconsistent with the terms of this Agreement; provided, however, that any impacts on, and upgrades required to, IID's Affected System (other than the JPP) shall be addressed in the Affected System Study Agreement and Affected System Construction and Operation Agreement to be executed between Interconnection Customer and IID. The Parties also agree that the cost estimates in this Agreement shall serve as the basis for the determination of the amounts of interconnection financial security required pursuant to Article 11.5, including the Interconnection Financial Security required pursuant to Section 9 of the CAISO's LGIP, rather than the cost estimates set forth in the Phase II Interconnection Study report.

Appendix A-2

Interconnection Facilities, JPP Network Upgrades, and Distribution Upgrades for Phase B of the Interconnection Project

The Generating Facility will have a total rated capacity of 500 MW based on both Phase A and Phase B achieving Commercial Operation. Appendix A-1 addresses Phase A of the Generating Facility and this Appendix A-2 addresses Phase B of the Generating Facility. If interconnection studies determined to be necessary pursuant to Section 4 of Appendix C show a need for additional Interconnection Facilities, JPP Network Upgrades, or Distribution Upgrades for Phase B of the Interconnection Project, this Agreement shall be amended in accordance with the provisions of Section 4 of Appendix C.

1. Phase B of the Generating Facility Description:

The Generating Facility consists of a photovoltaic solar field, inverters, a medium voltage collection system, an operations and maintenance building, and various other facilities. Phase B of the Generating Facility will consist of no more than 210 MW (net) of solar photovoltaic units.

The Interconnection Facilities associated with Phase B of the Generating Facility will include additional 34.5kV/500kV transformers and will be connected to the Switchyard via a single 500kV interconnection line separate from the Phase A 500kV interconnection line.

2. Point of Interconnection:

The Point of Interconnection for Phase B of the Generating Facility is the Switchyard. See Appendix C –Diagram.

3. Power Injection Limitation at the Point of Interconnection:

The maximum allowable injection of power into the Switchyard at the Point of Interconnection for Phase B of the Generating Facility shall be 210 MW.

4. Point of Change of Ownership:

The Point of Change of Ownership demarcation point of the high voltage conductors and static wires will be the first designed dead end structure outside of the Switchyard fence. The Point of Change of Ownership will be at the line jumper connection point on the Transmission Owners' dead-ended conductor. Interconnection Customer will provide, per APS specifications, required materials, including foundations, steel structures, insulators, attachment hardware and dead-end connectors to install and terminate conductors at this structure from Switchyard. APS will supply and install conductors to this point of attachment. Interconnection Customer will provide and install materials, including insulators, attachment hardware, conductors, dead-end connectors, and jumper connections, from the Generating Facility substation to the termination point on the dead end structure. See Appendix C – Diagram.

If overhead communication cable is utilized, the interconnection and ownership demarcation point will be a splice point located on the first designed dead-end structure for the high voltage conductor outside of the Switchyard fence. Interconnection Customer will provide required materials for attachment of cable to structures to this point from the Switchyard. APS will provide communication

cable to this point. Interconnection Customer will be responsible for providing materials and connection to APS termination at this location.

If underground communication cable is utilized, the interconnection and ownership demarcation point will be a manhole located outside of the Switchyard fence. APS will provide manhole and other materials required to install cable from the Switchyard. Interconnection Customer will be responsible for providing materials and connection to APS termination at this location.

5. Interconnection Facilities:

(a) Interconnection Customer's Interconnection Facilities.

The Interconnection Customer's Interconnection Facilities consist of additional 34.5/500 kV transformers and a generation tie line from the Generating Facility substation to the Point of Change of Ownership with the Transmission Owner's Interconnection Facilities. The Interconnection Customer's Interconnection Facilities also includes all metering equipment, if any, required for compliance with the CAISO Tariff.

The following is an equipment list from the Interconnection Customer's Interconnection Facilities:

34.5kV/500kV step up transformers
Revenue meter
Shunt capacitors
Transmission structure at ownership change

(b) Transmission Owners' Interconnection Facilities

The Transmission Owners' Interconnection Facilities consist of the facilities between the Point of Change of Ownership and Point of Interconnection in the Switchyard. This consists of one 500 kV disconnect switch, and a span of 500kV conductor. The protection equipment for Phase B of the Interconnection Project is also included in Transmission Owners' Interconnection Facilities as are the metering equipment for the interconnection.

The following is an equipment list from the Transmission Owners' Interconnection Facilities:

Intertie meter
3 500kV, 3000A, Vertical Break Switches
Conductor
Relays

6. JPP Network Upgrades:

APS will design and construct an additional line termination in the new 500kV Switchyard, which will be constructed for Phase A of the Interconnection Project.

The following is an equipment list from the Switchyard portion of the JPP Network Upgrades:

Breakers - 1 500kV, 3000A, 63kA
Switches - 2 500kV, 3000A, Vertical Break

A second breaker will be required when the Switchyard is converted from a ring bus alignment to a breaker and one half arrangement. The timing for this change will be driven by a fifth termination into the Switchyard.

7. Stand-Alone JPP Network Upgrades: None

8. Transmission Owners' Interconnection Facilities and JPP Network Upgrades Cost Summary:

Cost Estimate (2010 dollars)

<u>Element</u>	<u>Cost</u>	<u>Transmission Owner Share</u>		
		<u>APS</u>	<u>IID</u>	<u>SDG&E</u>
<u>Transmission Owners' Interconnection Facilities</u>				
<u>500kV conductor tie line</u>	<u>657,000</u>	<u>0</u>	<u>0</u>	<u>0</u>
<u>Disconnect Switches</u>	<u>150,000</u>	<u>0</u>	<u>0</u>	<u>0</u>
<u>Protection Equipment</u>	<u>375,000</u>	<u>0</u>	<u>0</u>	<u>0</u>
<u>Contingency</u>	<u>236,000</u>	<u>0</u>	<u>0</u>	<u>0</u>
<u>1) Subtotal</u>	<u>1,418,000</u>	<u>0</u>	<u>0</u>	<u>0</u>
<u>JPP Network Upgrades</u>				
<u>Switchyard Breaker</u>	<u>899,000</u>	<u>98,890</u>	<u>114,852</u>	<u>685,218</u>
<u>Deferred breaker</u>	<u>810,000</u>	<u>89,100</u>	<u>103,518</u>	<u>617,382</u>
<u>Contingency</u>	<u>342,000</u>	<u>37,620</u>	<u>43,708</u>	<u>260,672</u>
<u>2) Subtotal</u>	<u>2,051,000</u>	<u>225,610</u>	<u>262,118</u>	<u>1,563,272</u>
<u>3) Total Interconnection Project Cost (for cash flow and financial security) (lines 1 & 2)</u>	<u>3,469,000</u>	<u>381,590</u>	<u>443,338</u>	<u>2,644,072</u>
<u>4) Total Network Upgrades (for reimbursement to North Gila River Development, LLC) (line 2)</u>	<u>2,051,000</u>	<u>225,610</u>	<u>262,118</u>	<u>1,563,272</u>

9. Estimate of Monthly Incurred Costs for the Transmission Owners' Interconnection Facilities and JPP Network Upgrades:

An estimate of the monthly incurred costs is shown below.

<u>Month</u>	<u>Estimated Cost by Month</u>
<u>Oct 2011</u>	<u>26,416</u>
<u>Nov 2011</u>	<u>26,416</u>

<u>Dec 2011</u>	<u>26,416</u>
<u>Jan 2012</u>	<u>609,160</u>
<u>Feb 2012</u>	<u>609,160</u>
<u>Mar 2012</u>	<u>609,160</u>
<u>April 2012</u>	<u>465,980</u>
<u>May 2012</u>	<u>465,980</u>
<u>June 2012</u>	<u>465,980</u>
<u>July 2012</u>	<u>47,180</u>
<u>Aug 2012</u>	<u>47,180</u>
<u>Sept 2012</u>	<u>47,180</u>
<u>Oct 2012</u>	<u>11,396</u>
<u>Nov 2012</u>	<u>11,396</u>
<u>Total</u>	<u>3,469,200</u>

10. Invoicing and JPP Network Upgrade Repayment:

Invoices issued by APS on behalf of the Transmission Owner pursuant to Articles 12.1 and 12.2 of this Agreement for Phase B of the Generating Facility shall include the cumulative balance invoiced to date for the JPP Network Upgrades and the allocation of such balance to the Ownership Interests.

Within thirty (30) Calendar Days of the Commercial Operation Date for a Project Phase, APS, on behalf of the Transmission Owners, shall provide the Parties with a statement which indicates the Ownership Share of each of the Transmission Owners in the cost of the Network Upgrades which are to be repaid in accordance with the provisions of Article 11.4.2 of this Agreement.

- (a) SDG&E Share: Interconnection Customer and SDG&E have agreed that SDG&E shall make the repayment provided for in Article 11.4.2 of this Agreement by making a cash payment to North Gila River Development, LLC within sixty (60) Calendar Days of the Commercial Operation Date of each Project Phase.
- (b) APS Share: APS shall make the repayment provided for in Article 11.4.1 of this Agreement to North Gila River Development, LLC in accordance with the terms of this Agreement.
- (c) IID Share: IID shall make the repayment provided for in Article 11.4.3 of this Agreement to North Gila River Development, LLC in accordance with the terms of this Agreement.

11. Distribution Upgrades: None

12. Maintenance, Repair, and Replacement Charges:

The Interconnection Customer shall be responsible for actual costs incurred by APS, on behalf of the Transmission Owners, applicable to the maintenance, repair and replacement of the Transmission Owners' Interconnection Facilities, including but not limited to: the 500 kV disconnect switches, protection equipment for the Interconnection Customer's Interconnection Facilities, metering including CTs and PTs and communications equipment and all associated equipment (see Appendix C, Diagram). A good faith non-binding estimate of annual cost, for budgetary purposes only, is:

Estimate = \$ 1,000 per year

\$1,000 annually covers:

- Two inspections per year
- Relay maintenance (estimated at every 4-6 years)
- Disconnect switch maintenance (estimated at every 4-6 years)

Additional actual costs will be charged for:

- Emergency maintenance and repair work
- Replacement of failed or failing equipment

13. Provision of Security:

(a) Financial Security to be Posted: The amount available to be drawn under any credit support for the Transmission Owners' Interconnection Facilities and JPP Network Upgrades required to interconnect Phase B of the Generating Facility shall be:

<u>APS Share (11.00%)</u>	<u>\$381,612</u>
<u>IID Share (12.78%)</u>	<u>\$443,364</u>
<u>Subtotal of APS and IID Shares (23.78%)</u>	<u>\$824,976</u>
<u>SDG&E Share (76.22%)</u>	<u>\$2,644,224</u>
<u>TOTAL (100%)</u>	<u>\$3,469,200</u>

(b) Posting: The Interconnection Customer shall provide financial security for the Transmission Owners' Interconnection Facilities and JPP Network Upgrades no later than the milestone due date specified in Appendix B-2 in accordance with Article 11.5 of this Agreement. With respect to the financial security for APS and IID shares, Interconnection Customer shall post with APS, as Operating Agent, the amount for both the APS and IID shares specified in Section 13(a) of this Appendix A-2 in the form of one security instrument.

With respect to the Interconnection Financial Security for SDG&E, the amount posted shall be the amount SDG&E is to provide pursuant to Section 13(a) of this Appendix A-2. The Interconnection Financial Security shall be posted in accordance with the terms of the CAISO tariff.

The Parties agree that the Interconnection Customer shall be allowed to make substitutions of the security posted under this Agreement so long as the new security posted is reasonably acceptable to the Transmission Owners, as provided for in Article 11.5 of this Agreement, and in the amount required by this Agreement.

(c) Reduction of Amount of Security: Interconnection Customer shall make arrangements for financial security that provide for periodic reduction of the amount of the financial security upon receipt of instructions from APS, acting on behalf of the Transmission Owners. APS, on behalf of the Transmission Owners, shall provide periodic notices of reductions in the amount of the financial security required to be held to the financial institution(s) the Interconnection Customer selects to hold the financial security. APS shall provide such

notices to the financial institution holding the security for the APS and IID shares in accordance with the arrangements made by the Interconnection Customer with the financial institution(s), provided, however, that the procedures for providing notice are reasonably acceptable to APS. APS shall also provide notice to SDG&E and IID. Unless otherwise agreed by APS and the Interconnection Customer, APS shall provide notice monthly as payments are made in accordance with Article 12.1 and the financial security shall be reduced proportionately on a dollar-for-dollar by the payments made under this Agreement.

SDG&E agrees that within five (5) Calendar Days of receiving notice of a reduction in the amount of the security pursuant to this section, it shall inform the financial institution that holds the Interconnection Financial Security of the reduction in the amount of the security.

(d) Increases to Security Required Due to Change of Cost Estimates. In the event that APS, on behalf of the Transmission Owners, finds that the cost estimate for Transmission Owner Interconnection Facilities and Network Upgrades provided in this Appendix A-2 has increased, APS, on behalf of the Transmission Owners, shall have the option of (1) offsetting any reduction in the amount of security under Section 13(c) of this Appendix A-2 with the increase in the cost estimate, or (2) notifying Interconnection Customer of the required increase in its financial security to conform to the increased cost estimate.

(e) Enforcement of Security for Transmission Owners' Interconnection Facilities and JPP Network Upgrades: In the event that this Agreement is terminated in accordance with Article 2.3 and APS, on behalf of Transmission Owners, is required to determine the cost responsibility of the Interconnection Customer in accordance with Article 2.4 for Transmission Owners' Interconnection Facilities and JPP Network Upgrades set forth in this Appendix A-2, the Parties agree that in addition to following the procedures set forth elsewhere in the Agreement, the Transmission Owners shall proceed as follows:

- (1)** Subject to review and approval by all Transmission Owners, APS shall provide a statement indicating the total cost responsibility of the Interconnection Customer to all Transmission Owners and the allocation of this cost responsibility by Ownership Share ("Statement of Cost Responsibility"). This Statement of Cost Responsibility shall be accompanied by a detailed report which shows how the cost responsibility was determined, including information on all expenditures made on behalf of the Interconnection Customer, payments received, and bills outstanding.
- (2)** If the Interconnection Customer has cost responsibility, upon providing the Statement of Cost Responsibility and accompanying information, APS, on behalf of both APS and IID, shall enforce their financial security rights in proportion to the combined Ownership Interests of APS and IID.
- (3)** If the Interconnection Customer has cost responsibility, upon receipt of the Statement of Cost Responsibility and accompanying information, SDG&E shall enforce its financial security rights in proportion to the Ownership Interest of SDG&E. Within thirty (30) Calendar Days of receipt of the Statement of Cost Responsibility, SDG&E shall provide the funds it receives by enforcing its financial security rights to APS.
- (4)** APS, acting on behalf of the Transmission Owners, shall use the funds provided by enforcing the financial security rights of the Transmission Owners to provide reimbursements and settle accounts proportionately in accordance with the Statement of Cost Responsibility and accompanying report.

14. Reporting Requirements:

From the date upon which authorization to proceed is provided pursuant to Article 5.1.1 for Phase B of the Generating Facility until the In-Service Date for Phase B of the Interconnection Project, Interconnection Customer and APS shall conduct a monthly meeting to coordinate the work related to the Transmission Owners' Interconnection Facilities and JPP Network Upgrades in this Appendix A-2. APS shall submit a monthly written report to the Interconnection Customer in advance of the meeting that provides the following information:

- (a) Progress report on activities;
- (b) Project schedule update; and
- (c) Spending report, including actual expenditures to date and forecasted expenditures in accordance with standard accounting practices.

Appendix A-3

SDG&E Network Upgrades for Phase B of the Interconnection Project

If the interconnection studies determined to be necessary pursuant to Section 4 of Appendix C identify additional Network Upgrades to be constructed by SDG&E, the Parties shall amend this Agreement to incorporate provisions for those Network Upgrades into this Appendix A-3.

Appendix B to LGIA
Appendix B-1

Milestones

Appendix B-1 Milestones for Interconnection Facilities and JPP Network Upgrades for Phase A of the Interconnection Project

The Interconnection Customer has selected the Standard Option provided for in Article 5.1. Transmission Owners shall design, procure, and construct Transmission Owner's Interconnection Facilities and JPP Network Upgrades, using Reasonable Efforts to complete Transmission Owner's Interconnection Facilities and JPP Network Upgrades by the dates set forth in this Appendix B-1, Milestones. Milestone dates after October 1, 2010 may be adversely affected by an Effective Date later than October 1, 2010.

<u>Milestones for Interconnection Facilities and JPP Network Upgrades for Phase A of the Interconnection Project</u>	<u>Responsible Party</u>	<u>Due Date</u>
<u>Begin design, permitting and land acquisition for line cut-in facilities</u>	<u>Operating Agent</u>	<u>E&P Agreement</u>
<u>Begin major equipment procurement specifications</u>	<u>Operating Agent</u>	<u>E&P Agreement</u>
<u>Complete planning and equipment specifications</u>	<u>Operating Agent</u>	<u>E&P Agreement</u>
<u>Begin above grade design</u>	<u>Operating Agent</u>	<u>E&P Agreement</u>
<u>Begin below grade design</u>	<u>Operating Agent</u>	<u>E&P Agreement</u>
<u>Submit estimate of Interconnection Customer payments under E&P Agreement and financial security posting requirements</u>	<u>Operating Agent</u>	<u>9/15/2010 or within 5 Calendar Days of Effective Date, if later</u>
<u>Submit interconnection financial security (Sections 5.6.4 and 11.5)</u>	<u>Interconnection Customer</u>	<u>Within 10 Calendar Days of receipt of financial security requirements</u>
<u>Complete transmission line and tower design</u>	<u>Operating Agent</u>	<u>5/31/10</u>
<u>Complete above grade design</u>	<u>Operating Agent</u>	<u>7/30/2010</u>
<u>Additional long lead time material procurement: Breakers, Switches</u>	<u>Operating Agent</u>	<u>Q2 2010</u>
<u>Submit written notice to proceed for procurement of towers</u>	<u>Interconnection Customer</u>	<u>6/1/2010</u>

<u>Complete below grade design</u>	<u>Operating Agent</u>	<u>8/11/10</u>
<u>Submit written authorization to APS to proceed with the construction of the Switchyard portion of Transmission Owners' 500kV Network Upgrades (Section 5.1.1 Standard Option)</u>	<u>Interconnection Customer</u>	<u>10/1/2010 or within 15 Calendar Days of Effective Date, if later</u>
<u>Submit written authorization to APS to proceed with the construction of the transmission line portion of Transmission Owners' 500kV JPP Network Upgrades (section 5.1.1 Standard Option)</u>	<u>Interconnection Customer</u>	<u>11/15/2010 or within 15 Calendar Days of Effective Date, if later</u>
<u>Complete land services/environmental</u>	<u>Operating Agent</u>	<u>12/27/2010</u>
<u>Complete installation of towers and tie line</u>	<u>Operating Agent</u>	<u>3/1/2011</u>
<u>Complete below grade work</u>	<u>Operating Agent</u>	<u>3/1/2011</u>
<u>Complete major equipment procurement</u>	<u>Operating Agent</u>	<u>6/13/2011</u>
<u>Complete material deliveries</u>	<u>Operating Agent</u>	<u>7/11/2011</u>
<u>Complete communications work</u>	<u>Operating Agent</u>	<u>8/22/2011</u>
<u>Complete above grade work</u>	<u>Operating Agent</u>	<u>11/2/2011</u>
<u>Complete control work</u>	<u>Operating Agent</u>	<u>11/3/2011</u>
<u>Line Drop Complete</u>	<u>Operating Agent</u>	<u>11/1/2011</u>
<u>Testing/Commissioning Complete</u>	<u>Operating Agent</u>	<u>12/1/2011</u>
<u>In-Service Date for JPP Network Upgrades and Transmission Owners' Interconnection Facilities</u>	<u>Operating Agent</u>	<u>12/1/2011</u>
<u>In-Service Date for Interconnection Customer's Interconnection Facilities</u>	<u>Interconnection Customer</u>	<u>12/1/2011</u>
<u>Initial Synchronization Date</u>	<u>Interconnection Customer</u>	<u>12/15/2011</u>
<u>Commercial Operation Date (COD) of Phase A of Generating Facility</u>	<u>Interconnection Customer</u>	<u>6/30/2014</u>
<u>Release date of financial security provided for in Appendix A-1 for Phase A of the Interconnection Project</u>	<u>Operating Agent</u>	<u>30 Calendar Days after COD</u>

Early Operations

Given the modular nature of a photovoltaic solar facility, which is constructed in 1-2 MW Project Blocks, various stages of the Generating Facility will be added after Trial Operation of a Project Phase and will commence Commercial Operation prior to the Commercial Operation Date for the Project Phase. From the Initial Synchronization Date for each Project Phase, it is estimated that an additional 8-12 MW will be tested and commence Commercial Operation each month until the entire Project Phase is completed. Following the Initial Synchronization Date, Interconnection Customer will notify APS and CAISO at least ten (10) Calendar Days and not more than thirty (30) Calendar Days prior to the date each portion of the Project Phase with a generation capacity of at least one (1) MW but not more than twenty (20) MW will be completed and commence operation.

Further details regarding early operations will be included in an implementation plan. The proposed implementation plan shall be prepared by the Interconnection Customer and shall be submitted to APS, on behalf of Transmission Owners, and the CAISO for approval at least one-hundred twenty (120) Calendar Days prior to the scheduled In-Service Date for the Transmission Owners' Interconnection Facilities and JPP Network Upgrades for Phase A of the Interconnection Project. CAISO and APS, on behalf of Transmission Owners, shall provide written comments regarding the proposed implementation plan within thirty (30) Calendar Days of receipt. Interconnection Customer, CAISO, and APS shall work in good faith to finalize the implementation plan no later than sixty (60) Calendar Days prior to the scheduled In-Service Date.

Appendix B-2

Milestones for Interconnection Facilities and JPP Network Upgrades for Phase B of the Interconnection Project

The Interconnection Customer has selected the Standard Option provided for in Article 5.1. Transmission Owners shall design, procure, and construct Transmission Owner's Interconnection Facilities and JPP Network Upgrades, using Reasonable Efforts to complete Transmission Owner's Interconnection Facilities and JPP Network Upgrades by the dates set forth in this Appendix B-2, Milestones. Milestone dates after October 1, 2010 may be adversely affected by an Effective Date later than October 1, 2010.

<u>Milestones for Interconnection Facilities and JPP Network Upgrades for Phase B of the Interconnection Project</u>	<u>Responsible Party</u>	<u>Due Date</u>
<u>Submit written notification to Parties of the intended Balancing Authority for Phase B of the Generating Facility</u>	<u>Interconnection Customer</u>	<u>3/15/2011</u>
<u>Complete review of all available studies to determine whether there is a need for additional interconnection studies regarding the possible impacts of Phase B of the Generating Facility on the CAISO Transmission System.</u>	<u>CAISO</u>	<u>4/15/2011</u>
<u>If additional interconnection studies are needed, provide notification to the Parties of the process for having such additional interconnection studies done in accordance with the applicable interconnection process.</u>	<u>CAISO</u>	<u>Note (1)</u>
<u>Complete review of all available studies to determine whether there is a need for additional Affected System Study regarding the possible impacts of Phase B of the Generating Facility on IID's non-JPP facilities.</u>	<u>IID</u>	<u>5/15/ 2011</u>
<u>If additional Affected System Study is needed, provide notification to the Parties of the process for having such additional studies done.</u>	<u>IID</u>	<u>Note (1)</u>
<u>Submit written authorization to proceed with long lead time material procurement and submit procurement financial security</u>	<u>Interconnection Customer</u>	<u>10/1/2011</u>
<u>Begin long lead time material procurement: Breakers, Switches</u>	<u>Operating Agent</u>	<u>1/15/2012</u>
<u>Submit written authorization to APS to proceed with the construction of Phase B of the Interconnection Project and submit construction financial security (Sections 5.6.4 and 11.5)</u>	<u>Interconnection Customer</u>	<u>5/1/2012</u>
<u>In-Service Date for JPP Network Upgrades and Transmission Owners' Interconnection Facilities (conditioned on available outage period)</u>	<u>Operating Agent</u>	<u>10/15/2012</u>
<u>In-Service Date for Interconnection Customer's Interconnection</u>	<u>Interconnection Customer</u>	<u>10/15/2012</u>

<u>Facilities</u>		
<u>Initial Synchronization Date</u>	<u>Interconnection Customer</u>	<u>11/1/2012</u>
<u>Commercial Operation Date (COD) of Phase B of the Generating Facility</u>	<u>Interconnection Customer</u>	<u>6/15/2015</u>
<u>Release date of financial security provided for in Appendix A-2 for Phase B of the Interconnection Project</u>	<u>Operating Agent</u>	<u>30 Calendar Days after COD</u>

Note 1: If additional studies are required pursuant to Section 4 of Appendix C, the Parties will work together to amend this Agreement to modify this Appendix B-2 to establish a new schedule for Phase B of the Interconnection Project that is reasonably acceptable to all Parties.

Early Operations

Given the modular nature of a photovoltaic solar facility, which is constructed in 1-2 MW Project Blocks, various stages of the Generating Facility will be added after Trial Operation of a Project Phase and will commence Commercial Operation prior to the Commercial Operation Date for the Project Phase. From the Initial Synchronization Date for each Project Phase, it is estimated that an additional 8-12 MW will be tested and commence Commercial Operation each month until the entire Project Phase is completed. Following the Initial Synchronization Date, Interconnection Customer will notify APS and CAISO at least ten (10) Calendar Days and not more than thirty (30) Calendar Days prior to the date each portion of the Project Phase with a generation capacity of at least one (1) MW but not more than twenty (20) MW will be completed and commence operation.

Further details regarding early operations will be included in an implementation plan. The proposed implementation plan shall be prepared by the Interconnection Customer and shall be submitted to APS, on behalf of Transmission Owners, and the CAISO for approval at least one hundred twenty (120) Calendar Days prior to the scheduled In-Service Date for the Transmission Owners' Interconnection Facilities and JPP Network Upgrades for Phase B of the Interconnection Project. CAISO and APS, on behalf of Transmission Owners, shall provide written comments regarding the proposed implementation plan within thirty (30) Calendar Days of receipt. Interconnection Customer, CAISO, and APS shall work in good faith to finalize the implementation plan no later than sixty (60) Calendar Days prior to the scheduled In-Service Date.

Appendix B-3

Milestones for SDG&E Network Upgrades for Phase B of the Interconnection Project

If the interconnection studies determined to be necessary pursuant to Section 4 of Appendix C identify additional Network Upgrades to be constructed by SDG&E, the Parties shall amend this Agreement to incorporate milestones for the construction of those Network Upgrades into this Appendix B-3.

Appendix C ~~to LGIA~~

Interconnection Details

1. Description of the Large Generating Facility

The Generating Facility consists of a photovoltaic solar field, inverters, a medium voltage collection system, an operations and maintenance building, a 34.5kV/500kV substation and various other facilities. Phase A of the Generating Facility will consist of no more than 290 MW (net) of solar photovoltaic units installed at the site. Phase B of the Generating Facility will consist of no more than 210 MW (net). The Generating Facility will have with a total rated capacity of 500 MW based on both Phase A and Phase B achieving Commercial Operation.

Phase A of the Generating Facility will be interconnected to the Switchyard via a gen-tie line on the diagram below and Phase B of the Generating Facility will be interconnected to the Switchyard via a separate gen-tie line on the diagram.

2. Diagram Illustrating the Facilities at the Switchyard

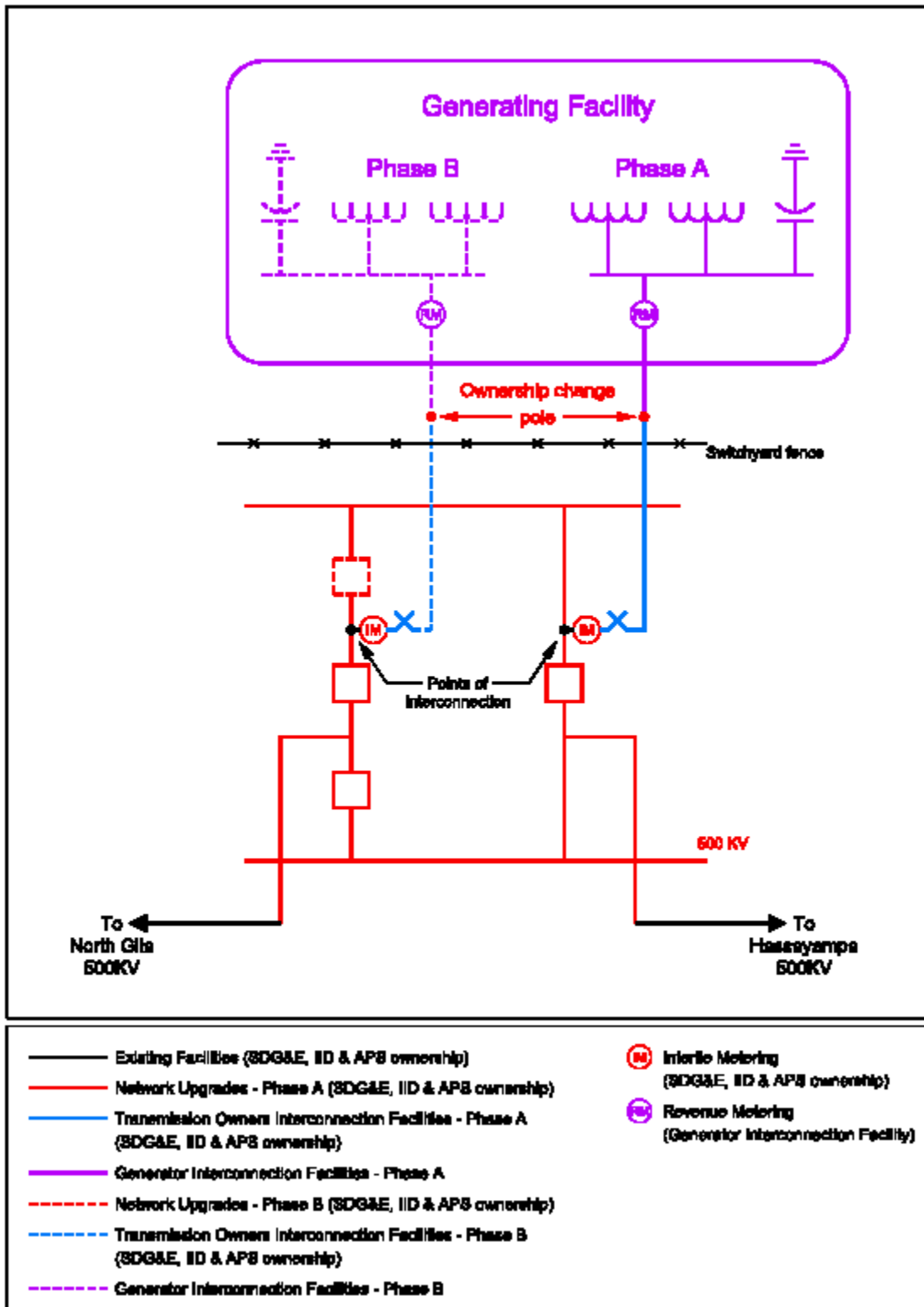

3. Balancing Authority Requirements:

If a Project Phase is to be under a Balancing Authority other than the APS's Balancing Authority, all executed agreements between Interconnection Customer and the other Balancing Authority relating to the Large Generating Facility shall be shared with APS, as the Operating Agent for the JPP.

4. Additional Conditions for Construction of Phase B of the Interconnection Project:

No later than March 15, 2011, Interconnection Customer shall notify the other Parties in writing of the intended Balancing Authority for Phase B of the Generating Facility. Construction of Phase B of the Interconnection Project shall not commence nor shall delivery of energy from Phase B of the Generating Facility to the Transmission System commence until all of the following actions have occurred:

- (a) Interconnection Customer will provide written authorization to APS to proceed with the construction of the Switchyard portion of Transmission Owners' 500kV Network Upgrades for Phase A of the Interconnection Project and Phase A of the Interconnection Project has not otherwise been suspended or terminated.
- (b) Within thirty (30) Calendar Days following receipt of the notice of intended Balancing Authority, the CAISO will review all available studies and determine whether there is a need for additional interconnection studies regarding the possible impacts of Phase B of the Generating Facility on the Transmission System.
- (c) If the CAISO concludes that there is a need for additional interconnection studies, within thirty (30) Calendar Days following receipt of the notice of intended Balancing Authority the CAISO will notify the Parties of the process for having CAISO conduct such additional interconnection studies, which may include the submittal by the Interconnection Customer of an additional Interconnection Request to the CAISO for Phase B of the Generating Facility in accordance with the CAISO's LGIP. Either in accordance with the CAISO's LGIP for a separate Interconnection Request for Phase B of the Generating Facility or pursuant to any other interconnection study process as specified by the CAISO or otherwise determined by FERC for the jurisdictional public utilities which are Parties to this Agreement, the CAISO and Interconnection Customer will enter into an interconnection study agreement under which the Interconnection Customer will agree to pay the reasonable and actual costs of the interconnection studies identified by the CAISO as needed, plus any study deposits required by the CAISO.
- (d) If the CAISO concludes on the basis of the studies provided for in Section 4(c) of this Appendix C that construction of additional facilities is required on the CAISO-controlled grid, this Agreement shall be amended to provide for construction of such facilities and for repayment of the cost of any such facilities that are Network Upgrades in accordance with the principles set forth in Article 11.4.2.
- (e) Within thirty (30) Calendar Days of its receipt of the notice provided by the CAISO in accordance with Section 4(c) of this Appendix C, IID shall determine whether there is a need for an additional Affected System Study regarding the possible impacts of Phase B of the Generating Facility on IID's Transmission System, other than IID's share of the JPP.
- (f) If IID concludes that there is a need for such an additional Affected System Study, IID shall notify the Parties of the process for having IID conduct such an additional Affected System Study and Interconnection Customer shall enter into an Affected System Study Agreement for Phase B of the Generating Facility.
- (g) If IID reasonably concludes on the basis of the studies provided for in Section 4(f) of this Appendix C that construction of additional IID Network Upgrades is required, the

Interconnection Customer and IID shall enter into an Affected System Construction and Operation Agreement for Phase B of the Generating Facility.

5. Joint and Several Liability for Entities Comprising Interconnection Customer

Except as otherwise provided, each entity comprising the Interconnection Customer shall be jointly and severally liable for all obligations required of the Interconnection Customer set forth in this Agreement, including all affirmative covenants and all monetary obligations, the latter of which includes the financing of all Interconnection Facilities and Network Upgrades that are required to be financed by the Interconnection Customer in order to accommodate the interconnection of the entire Generating Facility.

6. Representative of Entities Comprising Interconnection Customer

Agua Caliente Solar LLC and North Gila River Development, LLC shall appoint a single spokesperson, who shall serve as the Interconnection Customer's authorized agent and representative for purposes of administering this Agreement. The designated single spokesperson shall be a single point of contact for CAISO and Transmission Owners and will represent Interconnection Customer for notice purposes and all other communications between and among CAISO, Transmission Owners and Interconnection Customer. Except as otherwise provided, any invoices or refunds due to one of the entities comprising the Interconnection Customer by the Transmission Owners shall be made to the designated single spokesperson. The single spokesperson shall bear all responsibility for disseminating notices, communications and all interactions among the entities comprising the Interconnection Customer, and each entity comprising the Interconnection Customer hereby waives any right to individual notice or communication from CAISO or the Transmission Owners. The CAISO and the Transmission Owners will not be obligated to act on any instructions from either of the entities comprising the Interconnection Customer who is not the designated single spokesperson. The actions of the single spokesperson and his or her representations to CAISO and the Transmission Owners shall be binding upon the Interconnection Customer and each entity comprising the Interconnection Customer. This provision shall be of no further force and effect upon either the division of the Agreement obligations, as set forth in Section 7 of this Appendix C or the termination of Phase B of the Generating Facility, as set forth in Section 8 of this Appendix C.

7. Division of Agreement Obligations.

If the conditions for construction for Phase B of the Interconnection Project set out in Section 4 of this Appendix C have been met, the Interconnection Customer shall determine whether obtaining financing for the Generating Facility on commercially reasonable terms will require separate Large Generator Interconnection Agreements (LGIAs) for Phase A of the Generating Facility and Phase B of the Generating Facility. If the Interconnection Customer determines that separate LGIAs are needed, the Parties agree they shall negotiate in good faith to: (1) amend this Agreement solely for the purpose of making it apply only to Phase A of the Generating Facility and Phase A of the Interconnection Project; and (2) enter into a second LGIA for Phase B of the Generating Facility on terms that are substantially similar in all material relevant respects to this Agreement and to the amended version of this Agreement for Phase A of the Generating Facility. In such event, the joint and several liability set out in Section 5 of this Appendix C shall cease.

8. Termination of Phase B of the Generating Facility.

In addition to the termination right provided in Article 2.3 of this Agreement, and subject to its terms, those of Article 2.4 of the Agreement and any applicable Tariff, North Gila River Development, LLC may terminate this Agreement as it relates to Phase B of the Generating Facility provided the right to

terminate Phase B of the Generating Facility is conditioned on an obligation to fund the Network Upgrades set forth in Appendix A-2 in the event such termination constitutes a Material Modification of the Interconnection Request and is necessary to avoid adversely impacting lower queued interconnection customers. In the event North Gila River Development, LLC elects to terminate this Agreement as it relates to Phase B of the Generating Facility, this Agreement shall be amended accordingly so as to remove all references, terms and conditions pertaining to Phase B of the Generating Facility. Such termination shall leave unaffected the terms and conditions in this Agreement with respect to Phase A of the Generating Facility.

Appendix D ~~to~~ LGIA

Security Arrangements Details

Infrastructure security of Transmission System equipment and operations and control hardware and software is essential to ensure day-to-day Transmission System reliability and operational security. FERC will expect all ~~Transmission Providers~~[transmission providers](#), market participants, and Interconnection Customers interconnected to the Transmission System to comply with the recommendations offered by the President's Critical Infrastructure Protection Board and, eventually, best practice recommendations from the electric reliability authority. All public utilities will be expected to meet basic standards for system infrastructure and operational security, including physical, operational, and cyber-security practices.

If the Interconnection Customer selects the CAISO as the Balancing Authority for a Project Phase, for that Project Phase the Interconnection Customer shall meet the requirements for security implemented pursuant to the CAISO Tariff, including the CAISO's standards for information security posted on the CAISO's internet web site at the following internet address: <http://www.caiso.com/pubinfo/info-security/index.html>.

Appendix E ~~to LGIA~~

Commercial Operation Date

This Appendix E is a part of the ~~LGIA between Transmission Provider and Interconnection Customer~~ Agreement.

[Date]

~~_____ [Transmission Provider Address]~~

Arizona Public Service Co.
Attn: Manager of Interconnection Development
MS 2259
P.O. Box 53999
Phoenix, AZ 85072-3999

Mr. Stephen Rutt
Manager of Grid Assets
California Independent System Operator Corporation
151 Blue Ravine Road
Folsom, CA 95630

Mr. Robert Kott
Manager of Model & Contract Implementation
California Independent System Operator Corporation
151 Blue Ravine Road
Folsom, CA 95630

Re: ~~_____ Large~~ Commercial Operation Date of Phase _____ of the Generating Facility

Dear _____:

On [Date] [Interconnection Customer] ~~has~~ completed ~~Trial Operation of Unit No. _____ the last~~ Project Block of Phase _____ of the _____ Generating Facility. This letter confirms that ~~[Interconnection Customer] commenced~~ the Commercial Operation of Unit No. _____ at Date of Phase _____ of the Large Generating Facility, effective as of [Date plus one day]. Generating Facility, is [Date plus one day] and that [Entity Comprising Interconnection Customer] provided the CAISO's operations personnel advance notice of this intended _____ Commercial Operation Date no less than five Business Days prior to that date.

Thank you.

[Signature]

[Interconnection Customer Representative]

Appendix F ~~to~~ LGIA

Addresses for Delivery of Notices and Billings

Notices:-

Operating Agent:

Arizona Public Service Company
Attn: Manager of Interconnection Development
MS 2259
P.O. Box 53999
Phoenix, AZ 85072-3999

Transmission Owners:

Arizona Public Service Company
Attn: Manager of Interconnection Development
MS 2259
P.O. Box 53999
Phoenix, AZ 85072-3999

~~Transmission Provider:~~

~~[To be supplied.]~~

Imperial Irrigation District
Attention: Inter-Connect Transmission Contract Administrator
333 East Barioni Boulevard
PO Box 937
Imperial, CA 92251

San Diego Gas & Electric Company
Attn: Transmission Planning Manager
8316 Century Park Court, CP52A
San Diego, CA 92123-1593

California Independent System Operator Corporation

California ISO
Ms. Judy Brown
151 Blue Ravine Rd.
Folsom, CA 95630

Designated Single Spokesperson for Entities Comprising Interconnection Customer:

~~[To be supplied.]~~

Agua Caliente Solar, LLC (Phase A) and North Gila River Development, LLC (Phase B)
Attn: : Jim Filippi, Director of Transmission
353 Sacramento St.
Suite 2100

San Francisco, CA 94111

With a copy to:

NextLight Renewable Power, LLC

Attn: Robert F. Miller, Vice President & General Counsel

353 Sacramento St.

Suite 2100

San Francisco, CA 94111

Billings and Payments:

~~Transmission Provider:~~

~~[To be supplied.]~~

Operating Agent:

Arizona Public Service Company

Attn: Manager of Interconnection Development

MS 2259

P.O. Box 53999

Phoenix, AZ 85072-3999

Interconnection Customer:

Agua Caliente Solar, LLC (Phase A) and North Gila River Development, LLC (Phase B)

Attn: Controller

353 Sacramento St.

Suite 2100

San Francisco, CA 94111

~~[To be supplied.]~~

With a copy to:

NextLight Renewable Power, LLC

Attn: Jim Filippi, Director of Transmission

353 Sacramento St.

Suite 2100

San Francisco, CA 94111

California Independent System Operator Corporation

California ISO

Finance Dept.

Dennis Estrada

151 Blue Ravine Rd.

Folsom, CA 95630

Alternative Forms of Delivery of Notices (telephone, facsimile or email):

Transmission ~~Provider~~ Owners:

Arizona Public Service Company

Attn: Manager, Interconnections Development

MS 2259
P.O. Box 53999
Phoenix, AZ 85072-3999

502 South 2nd Avenue, MS 2259
Phoenix, AZ 85003

Phone: (602) 250-1644
Facsimile: (602) 250-1674
Email: Rex.Stulting@aps.com

Imperial Irrigation District
Attention: Inter-Connect Transmission Contract Administrator
333 East Barioni Boulevard
PO Box 937
Imperial, CA 92251

~~[To be supplied.]~~

San Diego Gas & Electric Company
Grid Operations Services Manager
Phone: 619-725-8637
Fax: 619-683-3291

California Independent System Operator Corporation
jbrown@caiso.com

Designated Single Spokesperson for Entities Comprising Interconnection Customer:

Agua Caliente Solar, LLC (Phase A) and North Gila River Development, LLC (Phase B)

Attn: Jim Filippi

353 Sacramento St.

Suite 2100

San Francisco, CA 94111

Phone: (415) 935-2498

Facsimile: (415) 935-2499

Email: jfilippi@nextlight.com

With a copy to:

NextLight Renewable Power, LLC

Attn: Robert F. Miller, Vice President & General Counsel

353 Sacramento St.

Suite 2100

San Francisco, CA 94111

Phone: (415) 935-2500

Facsimile: (415) 935-2501

For Billings:

Agua Caliente Solar, LLC (Phase A) and North Gila River Development, LLC (Phase B)

Attn: Controller

353 Sacramento St.
Suite 2100
San Francisco, CA 94111

Facsimile: (415) 935-2501
Email: ap@nextlight.com

Interconnection Customer Contact Information Regarding General Operating Issues

(Non Real-Time)

Interconnection Customer shall provide Contact information within 120 days of the expected energization of the Switchyard as part of the implementation plan.

Interconnection Customer Contact Information Regarding Real-Time Operating Issues

(Real-Time 24/7)

Interconnection Customer shall provide Contact information within 120 days of the expected energization of the Switchyard as part of the implementation plan.

Operating Agent Contact Information Regarding General Operating Issues

(Non Real-Time)

Arizona Public Service Company
Attn: Thomas Glock, Power Operations Manager
MS 2260
P.O. Box 53999
Phoenix, AZ 85072-3999

502 South 2nd Avenue, MS 2260
Phoenix, AZ 85003

Phone: APS shall provide within 120 days of the expected energization of the
Switchyard
Facsimile: APS shall provide within 120 days of the expected energization of the
Switchyard
Email: Thomas.Glock@aps.com

Operating Agent Contact Information Regarding Real-Time Operating Issues

(Real-Time 24/7)

APS Energy Control Center
ECC Supervisor

Transmission Issues

Phone: _____ APS shall provide within 120 days of the expected energization of the _____ Switchyard

Generation Issues

Phone: _____ APS shall provide within 120 days of the expected energization of the _____ Switchyard

Appendix G **to LGIA**

Requirements ~~for~~of a Wind Generating Plant

~~Appendix G sets forth requirements and provisions specific to a wind generating plant. All other requirements of this LGIA continue to apply to wind generating plant interconnections.~~

~~A. Technical Standards Applicable to a Wind Generating Plant~~

~~i. Low Voltage Ride-Through (LVRT) Capability~~

~~A wind generating plant shall be able to remain online during voltage disturbances up to the time periods and associated voltage levels set forth in the standard below. The LVRT standard provides for a transition period standard and a post-transition period standard.~~

~~Transition Period LVRT Standard~~

~~The transition period standard applies to wind generating plants subject to FERC Order 661 that have either: (i) interconnection agreements signed and filed with the Commission, filed with the Commission in unexecuted form, or filed with the Commission as non-conforming agreements between January 1, 2006 and December 31, 2006, with a scheduled in-service date no later than December 31, 2007, or (ii) wind generating turbines subject to a wind turbine procurement contract executed prior to December 31, 2005, for delivery through 2007.~~

- ~~1. Wind generating plants are required to remain in-service during three-phase faults with normal clearing (which is a time period of approximately 4–9 cycles) and single line to ground faults with delayed clearing, and subsequent post-fault voltage recovery to prefault voltage unless clearing the fault effectively disconnects the generator from the system. The clearing time requirement for a three-phase fault will be specific to the wind generating plant substation location, as determined by and documented by the transmission provider. The maximum clearing time the wind generating plant shall be required to withstand for a three-phase fault shall be 9 cycles at a voltage as low as 0.15 p.u., as measured at the high side of the wind generating plant step-up transformer (i.e., the transformer that steps the voltage up to the transmission interconnection voltage or “GSU”), after which, if the fault remains following the location-specific normal clearing time for three-phase faults, the wind generating plant may disconnect from the transmission system.~~
- ~~2. This requirement does not apply to faults that would occur between the wind generator terminals and the high side of the GSU or to faults that would result in a voltage lower than 0.15 per unit on the high side of the GSU serving the facility.~~
- ~~3. Wind generating plants may be tripped after the fault period if this action is intended as part of a special protection system.~~
- ~~4. Wind generating plants may meet the LVRT requirements of this standard by the performance of the generators or by installing additional equipment (e.g., Static VAR Compensator, etc.) within the wind generating plant or by a combination of generator performance and additional equipment.~~
- ~~5. Existing individual generator units that are, or have been, interconnected to the network at the same location at the effective date of the Appendix G LVRT~~

~~Standard are exempt from meeting the Appendix G LVRT Standard for the remaining life of the existing generation equipment. Existing individual generator units that are replaced are required to meet the Appendix G LVRT Standard.~~

~~Post-transition Period LVRT Standard~~

~~All wind generating plants subject to FERC Order No. 661 and not covered by the transition period described above must meet the following requirements:~~

- ~~1. Wind generating plants are required to remain in service during three-phase faults with normal clearing (which is a time period of approximately 4–9 cycles) and single line to ground faults with delayed clearing, and subsequent post-fault voltage recovery to prefault voltage unless clearing the fault effectively disconnects the generator from the system. The clearing time requirement for a three-phase fault will be specific to the wind generating plant substation location, as determined by and documented by the transmission provider. The maximum clearing time the wind generating plant shall be required to withstand for a three-phase fault shall be 9 cycles after which, if the fault remains following the location-specific normal clearing time for three-phase faults, the wind generating plant may disconnect from the transmission system. A wind generating plant shall remain interconnected during such a fault on the transmission system for a voltage level as low as zero volts, as measured at the high voltage side of the wind GSU.~~
- ~~2. This requirement does not apply to faults that would occur between the wind generator terminals and the high side of the GSU.~~
- ~~3. Wind generating plants may be tripped after the fault period if this action is intended as part of a special protection system.~~
- ~~4. Wind generating plants may meet the LVRT requirements of this standard by the performance of the generators or by installing additional equipment (e.g., Static VAR Compensator) within the wind generating plant or by a combination of generator performance and additional equipment.~~
- ~~5. Existing individual generator units that are, or have been, interconnected to the network at the same location at the effective date of the Appendix G LVRT Standard are exempt from meeting the Appendix G LVRT Standard for the remaining life of the existing generation equipment. Existing individual generator units that are replaced are required to meet the Appendix G LVRT Standard.~~

~~ii. Power Factor Design Criteria (Reactive Power)~~

~~A wind generating plant shall maintain a power factor within the range of 0.95 leading to 0.95 lagging, measured at the Point of Interconnection as defined in this LGIA, if the Transmission Provider's System Impact Study shows that such a requirement is necessary to ensure safety or reliability. The power factor range standard can be met by using, for example, power electronics designed to supply this level of reactive capability (taking into account any limitations due to voltage level, real power output, etc.) or fixed and switched capacitors if agreed to by the Transmission Provider, or a combination of the two. The Interconnection Customer shall not disable power factor equipment while the wind plant is in operation. Wind plants shall also be able to provide sufficient dynamic voltage support in lieu of the power system stabilizer and automatic voltage regulation at the generator excitation system if the System Impact Study shows this to be required for system safety or reliability.~~

~~iii. Supervisory Control and Data Acquisition (SCADA) Capability~~

~~The wind plant shall provide SCADA capability to transmit data and receive instructions from the Transmission Provider to protect system reliability. The Transmission Provider and the wind plant Interconnection Customer shall determine what SCADA information is essential for the proposed wind plant, taking into account the size of the plant and its characteristics, location, and importance in maintaining generation resource adequacy and transmission system reliability in its area.~~

[Intentionally Omitted as Inapplicable](#)

Appendix H
To LGIA

Reliability Management System Agreement

RELIABILITY MANAGEMENT SYSTEM AGREEMENT
by and between
[TRANSMISSION OPERATOR]
and
[GENERATOR]

THIS RELIABILITY MANAGEMENT SYSTEM AGREEMENT(the "Agreement"), is entered into this _____ day of _____, _____, by and between _____ (the "Transmission Operator") and _____ (the "Generator").

WHEREAS, there is a need to maintain the reliability of the interconnected electric systems encompassed by the WECC in a restructured and competitive electric utility industry;

WHEREAS, with the transition of the electric industry to a more competitive structure, it is desirable to have a uniform set of electric system operating rules within the Western Interconnection, applicable in a fair, comparable and non-discriminatory manner, with which all market participants comply; and

WHEREAS, the members of the WECC, including the Transmission Operator, have determined that a contractual Reliability Management System provides a reasonable, currently available means of maintaining such reliability.

NOW, THEREFORE, in consideration of the mutual agreements contained herein, and other good and valuable consideration, the receipt and sufficiency of which is hereby acknowledged, the Transmission Operator and the Generator agree as follows:

1. PURPOSE OF AGREEMENT

The purpose of this Agreement is to maintain the reliable operation of the Western Interconnection through the Generator's commitment to comply with certain reliability standards.

~~1. Definitions:~~

2. DEFINITIONS

In addition to terms defined in the beginning of this Agreement and in the Recitals hereto, for purposes of this Agreement the following terms shall have the meanings set forth beside them below.

Control Area means an electric system or systems, bounded by interconnection metering and telemetry, capable of controlling generation to maintain its interchange schedule with other Control Areas and contributing to frequency regulation of the Western Interconnection.

FERC means the Federal Energy Regulatory Commission or a successor agency.

~~1.1 — Member: Any party to the WECC Agreement.~~
Member means any party to the WECC Agreement.

Party means either the Generator or the Transmission Operator and Parties means both of the Generator and the Transmission Operator.

~~1.2 — Reliability Management System or RMS: The means the~~ contractual reliability management program implemented through the WECC Reliability Criteria Agreement, ~~Section 2 of the WECC RMS Agreement,~~ this ~~Appendix H Agreement,~~ and any similar contractual arrangement.

~~1.3 — Western Interconnection: The means the~~ area comprising those states and provinces, or portions thereof, in Western Canada, Northern Mexico and the Western United States in which Members of the WECC operate synchronously connected transmission systems.

Working Day means Monday through Friday except for recognized legal holidays in the state in which any notice is received pursuant to Section 8.

~~1.4 — WECC: The means the~~ Western Electricity Coordinating Council or ~~any~~ successor entity.

~~1.5 — WECC Agreement: The means the~~ Western Electricity Coordinating Council Agreement dated March 20, 1967, as such may be amended from time to time.

~~1.6 — WECC Reliability Criteria Agreement: The means the~~ Western Electricity Coordinating Council Reliability Criteria Agreement dated _____, _____ among the WECC and certain of its member ~~Transmission Providers~~ transmission operators, as such may be amended from time to time.

WECC RMS Agreement means an agreement between the WECC and the Transmission Operator requiring the Transmission Operator to comply with the reliability criteria contained in the WECC Reliability Criteria Agreement.

~~1.7 — WECC Staff: Those means those~~ employees of the WECC, including personnel hired by the WECC on a contract basis, designated as responsible for the administration of the RMS.

3. TERM AND TERMINATION

3.1 Term. This Agreement shall become effective [thirty (30) days after the date of issuance of a final FERC order accepting this Agreement for filing without requiring any changes to this Agreement unacceptable to either Party. Required changes to this Agreement shall be deemed unacceptable to a Party only if that Party provides notice to the other Party within fifteen (15) days of issuance of the applicable FERC order that such order is unacceptable]. [Note: if the interconnection agreement is not FERC jurisdictional, replace bracketed language with: [on the later of: (a) the date of execution; or (b) the effective date of the WECC RMS Agreement.]

3.2 Notice of Termination of WECC RMS Agreement. The Transmission Operator shall give the Generator notice of any notice of termination of the WECC RMS Agreement by the WECC or by the Transmission Operator within fifteen (15) days of receipt by the WECC or the Transmission Operator of such notice of termination.

3.3 Termination by the Generator. The Generator may terminate this Agreement as follows:

(a) following the termination of the WECC RMS Agreement for any reason by the WECC or by the Transmission Operator, provided such notice is provided within forty-five (45) days of the termination of the WECC RMS Agreement;

(b) following the effective date of an amendment to the requirements of the WECC Reliability Criteria Agreement that adversely affects the Generator, provided notice of such termination is given within forty-five (45) days of the date of issuance of a FERC order accepting such amendment for filing, provided further that the forty-five (45) day period within which notice of termination is required may be extended by the Generator for an additional forty-five (45) days if the Generator gives written notice to the Transmission Operator of such requested extension within the initial forty-five (45) day period; or

(c) on one year's written notice to the Transmission Operator and the WECC, following any change in the WECC Reliability Criteria Agreement that materially affects Generator's obligations.

3.4 Termination by the Transmission Operator. The Transmission Operator may terminate this Agreement on thirty (30) days' written notice following the termination of the WECC RMS Agreement for any reason by the WECC or by the Transmission Operator, provided such notice is provided within thirty (30) days of the termination of the WECC RMS Agreement.

3.5 Mutual Agreement. This Agreement may be terminated at any time by the mutual agreement of the Transmission Operator and the Generator.

~~2. Terms and Conditions~~

4. COMPLIANCE WITH AND AMENDMENT OF WECC RELIABILITY CRITERIA

~~2.1 Purpose. In order to maintain the reliable operation of the transmission grid, the WECC Reliability Criteria Agreement sets forth reliability criteria adopted by the WECC to which Interconnection Customer and Transmission Provider shall be required to comply.~~

~~2.2~~ **4.1 Compliance.** Intereconnection Customer shall with Reliability Criteria. The Generator agrees to comply with the requirements of the WECC Reliability Criteria Agreement, including the applicable WECC reliability criteria ~~set forth~~contained in Section IV of Annex A thereof, and, in the event of failure to comply, agrees to be subject to the sanctions applicable to such failure. ~~Such sanctions shall be assessed pursuant to the procedures contained in the WECC Reliability Criteria Agreement.~~ Each and all of the provisions of the WECC Reliability Criteria Agreement are hereby incorporated by reference into this Appendix H Agreement as though set forth fully herein, and ~~Intereconnection Customer~~the Generator shall for all purposes be considered a Participant, and shall be entitled to all of the rights and privileges and be subject to all of the obligations of a Participant, under and in connection with the WECC Reliability Criteria Agreement, including but not limited to the rights, privileges and obligations set forth in Sections 5, 6 and 10 of the WECC Reliability Criteria Agreement.

4.2 Modifications to WECC Reliability Criteria Agreement. The Transmission Operator shall notify the Generator within fifteen (15) days of the receipt of notice from the WECC of the initiation of any WECC process to modify the WECC Reliability Criteria Agreement. The WECC RMS Agreement specifies that such process shall comply with the procedures, rules, and regulations then applicable to the WECC for modifications to reliability criteria.

4.3 Notice of Modifications to WECC Reliability Criteria Agreement. If, following the process specified in Section 4.2, any modification to the WECC Reliability Criteria Agreement is to take effect, the Transmission Operator shall provide notice to the Generator at least forty-five (45) days before such modification is scheduled to take effect.

~~2.3 — Payment and Sanctions. Interconnection Customer shall be responsible for reimbursing Transmission Provider for any monetary sanctions assessed against Transmission Provider due to the action or inaction of Interconnection Customer, by WECC pursuant to the WECC Reliability Criteria Agreement. Interconnection Customer also shall be responsible for payment of any monetary sanction assessed against Interconnection Customer by WECC pursuant to the WECC Reliability Criteria Agreement. Any such payment shall be made pursuant to the procedures specified in the WECC Reliability Criteria Agreement.~~

4.4 Effective Date. Any modification to the WECC Reliability Criteria Agreement shall take effect on the date specified by FERC in an order accepting such modification for filing.

~~2.4~~ 4.5 Transfer of Control or Sale of Generation Facilities. In any sale or transfer of control of any generation facilities subject to this Agreement, ~~Interconnection Customer~~ the Generator shall as a condition of such sale or transfer require the acquiring party or transferee with respect to the transferred facilities either to assume the obligations of ~~Interconnection Customer~~ the Generator with respect to this Agreement or to enter into an agreement with ~~Transmission Provider imposing on the acquiring party or transferee the same obligations applicable to Interconnection Customer pursuant to this Appendix G~~ the Control Area Operator in substantially the form of this Agreement.

5. SANCTIONS

5.1 Payment of Monetary Sanctions. The Generator shall be responsible for payment directly to the WECC of any monetary sanction assessed against the Generator pursuant to this Agreement and the WECC Reliability Criteria Agreement. Any such payment shall be made pursuant to the procedures specified in the WECC Reliability Criteria Agreement.

~~2.5~~ 5.2 Publication. ~~Interconnection Customer~~ The Generator consents to the release by the WECC of information related to ~~Interconnection Customer~~ the Generator's compliance with this Agreement only in accordance with the WECC Reliability Criteria Agreement.

5.3 Reserved Rights. Nothing in the RMS or the WECC Reliability Criteria Agreement shall affect the right of the Transmission Operator, subject to any necessary regulatory approval, to take such other measures to maintain reliability, including disconnection, which the Transmission Operator may otherwise be entitled to take. Either Party shall have the right to make a unilateral filing with FERC to modify this Agreement with respect to any provision hereof under section 205, section 206, or any other applicable provision of the Federal Power Act and FERC's rules and regulations thereunder; provided that each Party shall have the right to protest any such filing by the other Party and to participate fully in any proceeding before FERC in which such modifications may be considered.

6. THIRD PARTIES

~~2.6 — Third Parties.~~ Except for the rights and obligations between the WECC and ~~Interconnection Customer~~ Generator specified in ~~this Appendix H, Sections 4 and 5,~~ this Agreement creates contractual rights and obligations solely between the Parties. Nothing in this Agreement shall create, as between the Parties or with respect to the WECC: (a~~1~~) any obligation or liability whatsoever (other than as expressly provided in this Agreement), or (b~~2~~) any duty or standard of care whatsoever. In addition, nothing in this Agreement shall create any duty, liability, or standard of care whatsoever as to any other party. Except for the rights, as a third-party beneficiary ~~under this Appendix H, with respect to Sections 4 and 5,~~ of the WECC against ~~Interconnection Customer~~ Generator, no third party shall have any rights whatsoever with respect to enforcement of any provision of this Agreement. Transmission ~~Provider~~ Operator and

~~Interconnection Customer Generator~~ expressly intend that the WECC is a third-party beneficiary to this ~~Appendix H Agreement~~, and the WECC shall have the right to seek to enforce against ~~Interconnection Customer any provision of this Appendix H; Generator any provisions of Sections 4 and 5~~, provided that specific performance shall be the sole remedy available to the WECC pursuant to ~~Appendix H of this Agreement~~, and ~~Interconnection Customer Generator~~ shall not be liable to the WECC pursuant to this Agreement for damages of any kind whatsoever (other than the payment of sanctions to the WECC, if so construed), whether direct, compensatory, special, indirect, consequential, or punitive.

7. REGULATORY APPROVALS

This Agreement shall be filed with FERC by the Transmission Operator under Section 205 of the Federal Power Act. In such filing, the Transmission Operator shall request that FERC accept this Agreement for filing without modification to become effective on the day after the date of a FERC order accepting this Agreement for filing.

8. NOTICES

Any notice, demand or request required or authorized by this Agreement to be given in writing to a Party shall be delivered by hand, courier or overnight delivery service, mailed by certified mail (return receipt requested) postage prepaid, faxed, or delivered by mutually agreed electronic means to such Party at the following address:

Fax: _____

Fax: _____

The designation of such person and/or address may be changed at any time by either Party upon receipt by the other of written notice. Such a notice served by mail shall be effective upon receipt. Notice transmitted by facsimile shall be effective upon receipt if received prior to 5:00 p.m. on a Working Day, and if not received prior to 5:00 p.m. on a Working Day, receipt shall be effective on the next Working Day.

9. APPLICABILITY

This Agreement (including all appendices hereto and, by reference, the WECC Reliability Criteria Agreement) constitutes the entire understanding between the Parties hereto with respect to the subject matter hereof, supersedes any and all previous understandings between the Parties with respect to the subject matter hereof, and binds and inures to the benefit of the Parties and their successors.

10. AMENDMENT

No amendment of all or any part of this Agreement shall be valid unless it is reduced to writing and signed by both Parties hereto. The terms and conditions herein specified shall remain in effect throughout the term and shall not be subject to change through application to the FERC or other governmental body or authority, absent the agreement of the Parties.

11. INTERPRETATION

Interpretation and performance of this Agreement shall be in accordance with, and shall be controlled by, the laws of the State of _____ but without giving effect to the provisions thereof relating to conflicts of law. Article and section headings are for convenience only and shall not affect the interpretation of this Agreement. References to articles, sections and appendices are, unless the context otherwise requires, references to articles, sections and appendices of this Agreement.

12. PROHIBITION ON ASSIGNMENT

This Agreement may not be assigned by either Party without the consent of the other Party, which consent shall not be unreasonably withheld; provided that the Generator may without the consent of the WECC or Transmission Operator assign this Agreement (a) as collateral security to aid in providing financing or refinancing for the construction, ownership or operation of the Generator's power generating facility, or (b) to any acquiring party or transferee referenced in Section 4.5 of this Agreement. If requested by Generator, Transmission Operator will enter into a consent on commercially reasonable terms to any assignment of this Agreement by Generator under this Section 12.

~~2.7 — Reserved Rights. Nothing in the RMS or the WECC Reliability Criteria Agreement shall affect the right of Transmission Provider, subject to any necessary regulatory approval, to take such other measures to maintain reliability, including disconnection, that Transmission Provider may otherwise be entitled to take.~~

13. SEVERABILITY

~~2.8 — Severability. If one or more provisions of this Appendix H herein shall be invalid, illegal or unenforceable in any respect, it shall be given effect to the extent permitted by applicable law, and such invalidity, illegality or unenforceability shall not affect the validity of the other provisions of this Agreement.~~

~~2.9 — Termination. Interconnection Customer may terminate its obligations pursuant to this Appendix G:~~

~~(a) — If after the effective date of this Appendix H, the requirements of the WECC Reliability Criteria Agreement applicable to Interconnection Customer are amended so as to adversely affect Interconnection Customer, provided that Interconnection Customer gives fifteen (15) days' notice of such termination to Transmission Provider and WECC within forty five (45) days of the date of issuance of a Commission order accepting such amendment for filing, provided further that the forty five (45) day period within which notice of termination is required may be extended by Interconnection Customer for an additional forty five (45) days if Interconnection Customer gives written notice to Transmission Provider of such requested extension within the initial forty five (45) day period; or~~

~~(b) — For any reason on one year's written notice to Transmission Provider and the WECC.~~

~~2.10 — Mutual Agreement. This Appendix H may be terminated at any time by mutual agreement of Transmission Provider and Interconnection Customer.~~

14. COUNTERPARTS

This Agreement may be executed in counterparts and each shall have the same force and effect as an original.

IN WITNESS WHEREOF, the Transmission Operator and the Generator have each caused this Reliability Management System Agreement to be executed by their respective duly authorized officers as of the date first above written.

By: _____
Name:
Title:

By: _____
Name:
Title:

ATTACHMENT D

Redline comparison of:

**(1) the CAISO *pro forma* LGIA in Appendix Z of the
CAISO FERC Electric Tariff, Fourth Replacement Volume No. II**

to

(2) the Agreement.

Attachment D uses the CAISO LGIA as the “original” document and the Agreement as the “new” document.

For ease of reference, the headers and footers were removed from the CAISO LGIA prior to the creation of the redline comparison; therefore, the deletion of the headers and footers is not reflected in the redline comparison. To the extent necessary, the Filing Parties request waiver of the requirements of sections 35.10(b) and (c), 18 C.F.R. §§ 35.10(b) and 35.10(c) with regard to the headers and footers.

**~~STANDARD~~-LARGE GENERATOR
INTERCONNECTION AGREEMENT (~~LGIA~~)
AMONG**

BY AND BETWEEN

**AGUA CALIENTE SOLAR, LLC, AND NORTH GILA RIVER DEVELOPMENT, LLC
[AS INTERCONNECTION CUSTOMER]**

AND

**~~[PARTICIPATING TO]~~
ARIZONA PUBLIC SERVICE COMPANY,
IMPERIAL IRRIGATION DISTRICT,
SAN DIEGO GAS & ELECTRIC COMPANY, AND
CALIFORNIA INDEPENDENT SYSTEM OPERATOR CORPORATION**

TABLE OF CONTENTS

	<u>Page</u>
<u>RECITALS</u>	<u>1</u>
ARTICLE 1. DEFINITIONS	2
<u>ARTICLE 1 DEFINITIONS</u>	<u>3</u>
ARTICLE 2. EFFECTIVE DATE, TERM AND TERMINATION	10
<u>ARTICLE 2 EFFECTIVE DATE, TERM, AND TERMINATION</u>	<u>11</u>
2.1 EFFECTIVE DATE	10 <u>11</u>
2.2 TERM OF AGREEMENT	10 <u>12</u>
2.3 TERMINATION PROCEDURES	10 <u>12</u>
2.3.1 WRITTEN NOTICE	10 <u>12</u>
2.3.2 DEFAULT	10 <u>12</u>
2.3.3 Suspension of Work	10
2.3.4	10
2.4 TERMINATION COSTS	10
2.4.1	11
2.4.2	12
2.4.3	12
2.5 DISCONNECTION	12 <u>14</u>
2.6 SURVIVAL	12 <u>14</u>
ARTICLE 3. REGULATORY FILINGS AND CAISO TARIFF COMPLIANCE	12
<u>ARTICLE 3. REGULATORY FILINGS</u>	<u>14</u>
3.1 FILING	12 <u>15</u>
3.2 Agreement Subject to CAISO Tariff	12
3.3 Relationship Between this LGIA and the CAISO Tariff	13
3.4 Relationship Between this LGIA and the QF PGA	13
ARTICLE 4. SCOPE OF SERVICE	13
<u>ARTICLE 4. SCOPE OF SERVICE</u>	<u>15</u>
4.1 INTERCONNECTION Service <u>PRODUCT OPTIONS</u>	13 <u>15</u>
<u>4.1.1 CAISO INTERCONNECTION SERVICE</u>	<u>15</u>
<u>4.1.2 ENERGY RESOURCE INTERCONNECTION SERVICE</u>	<u>15</u>
<u>4.1.2.1 THE PRODUCT</u>	<u>15</u>
<u>4.1.2.2 TRANSMISSION DELIVERY SERVICE IMPLICATIONS</u>	<u>15</u>

4.1.3	<u>NETWORK RESOURCE INTERCONNECTION SERVICE</u>	16
	<u>4.1.3.1 THE PRODUCT</u>	16
	<u>4.1.3.2 TRANSMISSION DELIVERY SERVICE IMPLICATIONS</u>	16
4.2	PROVISION OF SERVICE	13 16
4.3	PERFORMANCE STANDARDS	13 16
4.4	NO TRANSMISSION <u>DELIVERY SERVICE</u>	14 16
4.5	INTERCONNECTION CUSTOMER PROVIDED SERVICES	14 16

~~ARTICLE 5. INTERCONNECTION FACILITIES ENGINEERING, PROCUREMENT, AND CONSTRUCTION~~ **~~14~~**

ARTICLE 5. INTERCONNECTION FACILITIES ENGINEERING, PROCUREMENT, AND CONSTRUCTION

	<u>CONSTRUCTION</u>	16
5.1	OPTIONS.....	14 17
	5.1.1 STANDARD OPTION.....	14 17
	5.1.2 ALTERNATE OPTION	15 17
	5.1.3 OPTION TO BUILD	15 17
	5.1.4 NEGOTIATED OPTION.....	15 17
5.2	GENERAL CONDITIONS APPLICABLE TO OPTION TO BUILD.....	16 17
5.3	LIQUIDATED DAMAGES.....	18 17
5.4	POWER SYSTEM STABILIZERS	19 17
5.5	EQUIPMENT PROCUREMENT	19 18
	5.5.1	19
	5.5.2	19
	5.5.3	19
5.6	CONSTRUCTION COMMENCEMENT	19 18
	5.6.1	20
	5.6.2	20
	5.6.3	20
	5.6.4	20
5.7	WORK PROGRESS.....	20 18
5.8	INFORMATION EXCHANGE	20 19
5.9	LIMITED OPERATION.....	20 19
5.10	INTERCONNECTION CUSTOMER'S INTERCONNECTION FACILITIES (<u>'ICIF'</u>)	21 19
	5.10.1 Large Generating Facility and INTERCONNECTION CUSTOMER'S INTERCONNECTION Facilities <u>FACILITY</u> SPECIFICATIONS.....	21 19

5.10.2	Participating TO's <u>REVIEW BY TRANSMISSION OWNERS</u> AND CAISO's Review	24 <u>19</u>
5.10.3	Interconnection Customer's Interconnection Facilities <u>ICIF</u> <u>CONSTRUCTION</u>	20 <u>20</u>
	Construction	21 <u>21</u>
5.10.4	Interconnection Customer to Meet Requirements of the Participating TO's Interconnection Handbook	22 <u>22</u>
5.11	Participating TO's <u>TRANSMISSION OWNERS'</u> INTERCONNECTION FACILITIES CONSTRUCTION	22 <u>20</u>
5.12	ACCESS RIGHTS	22 <u>20</u>
5.13	LANDS OF OTHER PROPERTY OWNERS	23 <u>21</u>
5.14	PERMITS	23 <u>21</u>
5.15	EARLY CONSTRUCTION OF BASE CASE FACILITIES	23 <u>21</u>
5.16	SUSPENSION	23 <u>21</u>
5.17	TAXES	24 <u>22</u>
5.17.1	INTERCONNECTION CUSTOMER PAYMENTS NOT TAXABLE	24 <u>22</u>
5.17.2	REPRESENTATIONS AND COVENANTS	24 <u>22</u>
5.17.3	INDEMNIFICATION FOR THE COST CONSEQUENCES OF CURRENT TAX LIABILITY IMPOSED UPON THE Participating TO <u>TRANSMISSION</u> <u>OWNER</u>	25 <u>23</u>
5.17.4	TAX GROSS-UP AMOUNT	26 <u>23</u>
5.17.5	PRIVATE LETTER RULING OR CHANGE OR CLARIFICATION OF LAW	27 <u>24</u>
5.17.6	SUBSEQUENT TAXABLE EVENTS	27 <u>24</u>
5.17.7	CONTESTS	27 <u>24</u>
5.17.8	REFUND	28 <u>25</u>
5.17.9	TAXES OTHER THAN INCOME TAXES	29 <u>26</u>
5.18	TAX STATUS	30 <u>27</u>
5.19	MODIFICATION	30 <u>27</u>
5.19.1	GENERAL	30 <u>27</u>
5.19.2	STANDARDS	31 <u>28</u>
5.19.3	MODIFICATION COSTS	31 <u>28</u>
	ARTICLE 6. TESTING AND INSPECTION	31 <u>31</u>
	<u>ARTICLE 6. TESTING AND INSPECTION</u>	<u>28</u>
6.1	PRE-COMMERCIAL OPERATION DATE TESTING AND MODIFICATIONS	31 <u>28</u>

6.2	POST-COMMERCIAL OPERATION DATE TESTING AND MODIFICATIONS	31 <u>29</u>
6.3	RIGHT TO OBSERVE TESTING	32 <u>29</u>
6.4	RIGHT TO INSPECT	32 <u>29</u>
ARTICLE 7. METERING		32
<u>ARTICLE 7. METERING</u>		<u>29</u>
7.1	GENERAL	32 <u>29</u>
7.2	CHECK METERS	33 <u>30</u>
7.3	Participating TO Retail Metering Standards	33 <u>30</u>
7.4	<u>TESTING OF METERING EQUIPMENT</u>	<u>30</u>
7.5	<u>METERING DATA</u>	<u>30</u>
7.6	<u>METERING REQUIREMENTS OF CAISO</u>	<u>30</u>
ARTICLE 8. COMMUNICATIONS		33
<u>ARTICLE 8. COMMUNICATIONS</u>		<u>31</u>
8.1	INTERCONNECTION CUSTOMER OBLIGATIONS	33 <u>31</u>
8.2	REMOTE TERMINAL UNIT	33 <u>31</u>
8.3	NO ANNEXATION	34 <u>32</u>
8.4	<u>COMMUNICATION REQUIREMENTS OF CAISO</u>	<u>32</u>
ARTICLE 9. OPERATIONS		34
<u>ARTICLE 9. OPERATIONS</u>		<u>32</u>
9.1	GENERAL	34 <u>32</u>
9.2	BALANCING AUTHORITY AREA NOTIFICATION	34 <u>32</u>
9.3	TRANSMISSION OWNER AND CAISO and Participating TO OBLIGATIONS	34 <u>32</u>
9.4	INTERCONNECTION CUSTOMER OBLIGATIONS	35 <u>32</u>
9.5	START-UP AND SYNCHRONIZATION	35 <u>33</u>
9.6	REACTIVE POWER	35 <u>33</u>
9.6.1	POWER FACTOR DESIGN CRITERIA	35 <u>33</u>
9.6.2	VOLTAGE SCHEDULES	35 <u>33</u>
9.6.2.1	GOVERNORS AND REGULATORS	36 <u>34</u>
9.6.3	PAYMENT FOR REACTIVE POWER	37 <u>34</u>
9.7	OUTAGES AND INTERRUPTIONS	37 <u>34</u>

9.7.1	OUTAGES	37 <u>34</u>
9.7.1.1	OUTAGE AUTHORITY AND COORDINATION.....	37 <u>34</u>
9.7.1.2	OUTAGE SCHEDULES	37 <u>35</u>
9.7.1.3	OUTAGE RESTORATION.....	38 <u>35</u>
9.7.2	INTERRUPTION OF SERVICE	38 <u>36</u>
	9.7.2.1	38
	9.7.2.2	38
	9.7.2.3	38
	9.7.2.4	39
	9.7.2.5	39
9.7.3	UNDER-FREQUENCY AND OVER-FREQUENCY CONDITIONS	39 <u>37</u>
9.7.4	SYSTEM PROTECTION AND OTHER CONTROL REQUIREMENTS	39 <u>37</u>
9.7.4.1	SYSTEM PROTECTION FACILITIES	39 <u>37</u>
	9.7.4.2	40
	9.7.4.3	40
	9.7.4.4	40
	9.7.4.5	40
	9.7.4.6	40
9.7.5	REQUIREMENTS FOR PROTECTION.....	40 <u>38</u>
9.7.6	POWER QUALITY.....	41 <u>38</u>
9.8	SWITCHING AND TAGGING RULES.....	41 <u>38</u>
9.9	USE OF INTERCONNECTION FACILITIES BY THIRD PARTIES.....	41 <u>38</u>
9.9.1	PURPOSE OF INTERCONNECTION FACILITIES	41 <u>39</u>
9.9.2	THIRD PARTY USERS	42 <u>39</u>
9.10	DISTURBANCE ANALYSIS DATA EXCHANGE.....	42 <u>39</u>
ARTICLE 10. MAINTENANCE		42
<u>ARTICLE 10. MAINTENANCE.....</u>		<u>39</u>
10.1	Participating TO <u>TRANSMISSION OWNER</u> OBLIGATIONS	42 <u>39</u>
10.2	INTERCONNECTION CUSTOMER OBLIGATIONS	42 <u>39</u>
10.3	COORDINATION.....	42 <u>39</u>
10.4	SECONDARY SYSTEMS	42 <u>40</u>
10.5	OPERATING AND MAINTENANCE EXPENSES.....	43 <u>40</u>
ARTICLE 11. PERFORMANCE OBLIGATION		43
<u>ARTICLE 11. PERFORMANCE OBLIGATION.....</u>		<u>40</u>

11.1	INTERCONNECTION CUSTOMER'S INTERCONNECTION FACILITIES	43 <u>40</u>
11.2	Participating TO's <u>TRANSMISSION OWNERS'</u> INTERCONNECTION FACILITIES	43 <u>40</u>
11.3	NETWORK UPGRADES AND DISTRIBUTION UPGRADES.....	43 <u>40</u>
11.4	TRANSMISSION CREDITS	43 <u>40</u>
11.4.1	REPAYMENT OF AMOUNTS ADVANCED <u>TO APS</u> FOR NETWORK UPGRADES <u>TO APS'S SHARE OF THE JPP</u>	44 <u>40</u>
11.4.2	<u>REPAYMENT OF AMOUNTS ADVANCED TO SDG&E FOR NETWORK UPGRADES TO ITS SHARE OF THE JPP AND TO ITS NON-JPP FACILITIES</u>	41 <u>41</u>
11.4.3	<u>REPAYMENT OF AMOUNTS ADVANCED TO IID FOR NETWORK UPGRADES TO IID'S SHARE OF THE JPP</u>	42 <u>42</u>
11.4.4	<u>SPECIAL PROVISIONS FOR AFFECTED SYSTEMS</u>	44 <u>43</u>
	11.4.3	45 <u>45</u>
11.5	PROVISION OF SECURITY.....	45 <u>44</u>
	11.5.1	45 <u>45</u>
	11.5.2	45 <u>45</u>
	11.5.3	45 <u>45</u>
11.6	INTERCONNECTION CUSTOMER COMPENSATION.....	45 <u>46</u>
11.6.1	INTERCONNECTION CUSTOMER COMPENSATION FOR ACTIONS DURING EMERGENCY CONDITION.....	45 <u>46</u>
 ARTICLE <u>ARTICLE 12. -INVOICE</u> <u>INVOICE</u>		46 <u>46</u>
12.1	GENERAL <u>PROVISIONS</u>	46 <u>46</u>
12.2	FINAL INVOICE.....	46 <u>47</u>
12.3	PAYMENT.....	46 <u>47</u>
12.4	DISPUTES	47 <u>47</u>
 ARTICLE 13. - EMERGENCIES		47 <u>47</u>
<u>ARTICLE 13. EMERGENCIES</u>		48 <u>48</u>
13.1	[Reserved] <u>DEFINITION</u>	47 <u>48</u>
13.2	OBLIGATIONS.....	47 <u>48</u>
13.3	NOTICE	47 <u>48</u>
13.4	IMMEDIATE ACTION.....	48 <u>48</u>
13.5	<u>TRANSMISSION OWNER AND</u> CAISO and Participating TO AUTHORITY	48 <u>49</u>

13.5.1	GENERAL	48 <u>49</u>
13.5.2	REDUCTION AND DISCONNECTION	49
13.6	INTERCONNECTION CUSTOMER AUTHORITY	49 <u>50</u>
13.7	LIMITED LIABILITY	49 <u>50</u>
ARTICLE 14. REGULATORY REQUIREMENTS AND GOVERNING LAWS		49
<u>ARTICLE 14. REGULATORY REQUIREMENTS AND GOVERNING LAW</u>		<u>50</u>
14.1	REGULATORY REQUIREMENTS	49 <u>50</u>
14.2	GOVERNING LAW	50
	14.2.1	50
	14.2.2	50
	14.2.3	50
ARTICLE<u>ARTICLE</u> 15. NOTICES <u>NOTICES</u>		50
15.1	GENERAL	50
15.2	BILLINGS AND PAYMENTS	50 <u>51</u>
15.3	ALTERNATIVE FORMS OF NOTICE	50 <u>51</u>
15.4	OPERATIONS AND MAINTENANCE NOTICE	50 <u>51</u>
ARTICLE<u>ARTICLE</u> 16. FORCE MAJEURE		51
16.1	FORCE MAJEURE	51
	16.1.1	51
	16.1.2	51
ARTICLE<u>ARTICLE</u> 17. DEFAULT <u>DEFAULT</u>		51
17.1	DEFAULT	51
	17.1.1 GENERAL	51
	17.1.2 RIGHT TO TERMINATE	51 <u>52</u>
ARTICLE 18. INDEMNITY, CONSEQUENTIAL DAMAGES, AND INSURANCE		52
<u>ARTICLE 18. INDEMNITY, CONSEQUENTIAL DAMAGES AND INSURANCE</u>		<u>52</u>
18.1	INDEMNITY	52
	18.1.1 INDEMNIFIED PARTY	52
	18.1.2 INDEMNIFYING PARTY	52

18.1.3	INDEMNITY PROCEDURES	52
18.2	CONSEQUENTIAL DAMAGES.....	53
18.3	INSURANCE	53
18.3.1	53
18.3.2	53
18.3.3	54
18.3.4	54
18.3.5	54
18.3.6	54
18.3.7	54
18.3.8	55
18.3.9	55
18.3.10	55
18.3.11	55
ARTICLE <u>ARTICLE</u> 19.	ASSIGNMENT	55
19.1	ASSIGNMENT	55
ARTICLE <u>ARTICLE</u> 20.	SEVERABILITY	56
20.1	SEVERABILITY	56 <u>55</u>
ARTICLE <u>ARTICLE</u> 21.	COMPARABILITY	56
21.1	COMPARABILITY	56
ARTICLE 22.	CONFIDENTIALITY	56
<u>ARTICLE 22.</u>	<u>CONFIDENTIALITY</u>	<u>56</u>
22.1	CONFIDENTIALITY	56
22.1.1	TERM	57 <u>56</u>
22.1.2	SCOPE	57 <u>56</u>
22.1.3	RELEASE OF CONFIDENTIAL INFORMATION	57
22.1.4	RIGHTS.....	58 <u>57</u>
22.1.5	NO WARRANTIES	58 <u>57</u>
22.1.6	STANDARD OF CARE	58 <u>57</u>
22.1.7	Order of DISCLOSURE <u>REQUIRED BY LAW OR ORDER</u>	58 <u>57</u>
22.1.8	TERMINATION OF AGREEMENT	58
22.1.9	REMEDIES	58

22.1.10	DISCLOSURE TO FERC, ITS STAFF, OR A STATE.....	59 <u>58</u>
22.1.11	59
ARTICLE 23. ENVIRONMENTAL RELEASES		60
23.1	60
<u>ARTICLE 23. ENVIRONMENTAL RELEASES.....</u>		<u>59</u>
ARTICLE 24. INFORMATION REQUIREMENTS		60
<u>ARTICLE 24. INFORMATION REQUIREMENTS</u>		<u>59</u>
24.1	INFORMATION ACQUISITION	60 <u>59</u>
24.2	INFORMATION SUBMISSION BY Participating TO <u>APS, ON BEHALF OF</u> <u>TRANSMISSION OWNERS</u>	60 <u>59</u>
24.3	UPDATED INFORMATION SUBMISSION BY INTERCONNECTION CUSTOMER	60 <u>59</u>
24.4	INFORMATION SUPPLEMENTATION.....	61 <u>60</u>
ARTICLE 25. INFORMATION ACCESS AND AUDIT RIGHTS		62
<u>ARTICLE 25. INFORMATION ACCESS AND AUDIT RIGHTS</u>		<u>61</u>
25.1	INFORMATION ACCESS.....	62 <u>61</u>
25.2	REPORTING OF NON-FORCE MAJEURE EVENTS.....	62 <u>61</u>
25.3	AUDIT RIGHTS	62 <u>61</u>
	25.3.1	62
	25.3.2	63
25.4	AUDIT RIGHTS PERIODS.....	63 <u>61</u>
25.4.1	AUDIT RIGHTS PERIOD FOR CONSTRUCTION-RELATED ACCOUNTS AND RECORDS.....	63 <u>62</u>
25.4.2	AUDIT RIGHTS PERIOD FOR ALL OTHER ACCOUNTS AND RECORDS	63 <u>62</u>
25.5	AUDIT RESULTS	63 <u>62</u>
	25.5.1	64
ARTICLE 26. SUBCONTRACTORS		64
<u>ARTICLE 26. SUBCONTRACTORS.....</u>		<u>62</u>
26.1	GENERAL	64 <u>62</u>
26.2	RESPONSIBILITY OF PRINCIPAL	64 <u>62</u>
26.3	NO LIMITATION BY INSURANCE.....	64 <u>62</u>
ARTICLE 27. DISPUTES		64
<u>ARTICLE 27. DISPUTES.....</u>		<u>62</u>

27.1	SUBMISSION.....	6463
27.2	EXTERNAL ARBITRATION PROCEDURES.....	6563
27.3	ARBITRATION DECISIONS.....	6563
27.4	COSTS	6563
ARTICLE 28. REPRESENTATIONS, WARRANTIES AND COVENANTS.....		66
<u>ARTICLE 28. REPRESENTATIONS, WARRANTIES, AND COVENANTS</u>		<u>63</u>
28.1	GENERAL	6664
28.1.1	GOOD STANDING	6664
28.1.2	AUTHORITY	6664
28.1.3	NO CONFLICT	6664
28.1.4	CONSENT AND APPROVAL.....	6664
ARTICLE 29. [RESERVED].....		66
<u>ARTICLE 29. JOINT OPERATING COMMITTEE.....</u>		<u>64</u>
ARTICLE 30. MISCELLANEOUS.....		67
<u>ARTICLE 30. MISCELLANEOUS</u>		<u>65</u>
30.1	BINDING EFFECT	6765
30.2	CONFLICTS.....	6765
30.3	RULES OF INTERPRETATION	6765
30.4	ENTIRE AGREEMENT	6766
30.5	NO THIRD PARTY BENEFICIARIES	6766
30.6	WAIVER	6866
30.7	HEADINGS.....	6866
30.8	MULTIPLE COUNTERPARTS	6866
30.9	AMENDMENT	6866
30.10	MODIFICATION BY THE PARTIES	6866
30.11	RESERVATION OF RIGHTS	6867
30.12	NO PARTNERSHIP.....	6967
30.13	JOINT AND SEVERAL OBLIGATIONS.....	6967

APPENDICES

Appendices71

Appendix A -1 Interconnection Facilities, JPP Network Upgrades, and Distribution Upgrades for Phase A of the Interconnection Project

Appendix A-2 Interconnection Facilities, JPP Network Upgrades, and Distribution Upgrades for Phase B of the Interconnection Project

Appendix A-3 SDG&E Network Upgrades for Phase B of the Interconnection Project

Appendix B-1 Milestones for Interconnection Facilities and JPP Network Upgrades for Phase A of the Interconnection Project

Appendix B-2 Milestones for Interconnection Facilities and JPP Network Upgrades for Phase B of the Interconnection Project

Appendix B -3 Milestones for SDG&E Network Upgrades for Phase B of the Interconnection Project

Appendix C Interconnection Details

Appendix D Security Arrangements Details

Appendix E Commercial Operation Date

Appendix F Addresses for Delivery of Notices and Billings

~~Appendix G Interconnection Customer's Proportional Share of Costs of Network Upgrades for Applicable Project Group~~

~~Appendix H Interconnection Requirements for of a Wind Generating Plant~~

Appendix H Reliability Management System Agreement

LARGE GENERATOR INTERCONNECTION AGREEMENT

~~**{INTERCONNECTION CUSTOMER}**~~

~~**{PARTICIPATING TO}**~~

~~**CALIFORNIA INDEPENDENT SYSTEM OPERATOR CORPORATION**~~

THIS LARGE GENERATOR INTERCONNECTION AGREEMENT

(~~"LGIA"~~ "Agreement") is made and entered into this ____ day of _____, 20____, ~~by and among _____, a _____,~~ by and between Agua Caliente Solar, LLC, to which NextLight Renewable Power, LLC ("NextLight") has duly assigned its Interconnection Requests only as to Phase A of the Generating Facility, and North Gila River Development, LLC, to which NextLight has duly assigned its Interconnection Request submitted only to APS only as to Phase B of the Generating Facility, each of which is a corporation organized and existing under the laws of the State/~~Commonwealth of _____~~ (~~of Delaware, (collectively Agua Caliente Solar, LLC and North Gila River Development, LLC are the~~ "Interconnection Customer" with a Large Generating Facility), _____ and Arizona Public Service Company ("APS"), a corporation organized and existing under the laws of the State of ~~California ("Participating TO")~~ Arizona, Imperial Irrigation District ("IID"), an irrigation district organized under the Water Code of the State of California, San Diego Gas & Electric Company ("SDG&E"), a corporation organized under the laws of the State of California, and California Independent System Operator Corporation ("CAISO"), a ~~California~~ nonprofit public benefit corporation organized and existing under the laws of ~~the State of~~ California (~~"CAISO")~~. Interconnection Customer, ~~Participating TO,~~ APS, IID, SDG&E and CAISO each may be referred to as a "Party" or collectively as the "Parties."

RECITALS

Recitals

WHEREAS, APS and SDG&E entered into the Arizona Transmission System Participation Agreement, dated June 24, 1981 ("Participation Agreement");

WHEREAS, APS, IID, and SDG&E entered into Amendment No. 1 to the Participation Agreement, dated January 22, 1985 ("Amendment No. 1"), pursuant to which SDG&E assigned and transferred an undivided interest in the Arizona Transmission System to IID;

WHEREAS, APS, IID, and SDG&E ("Joint Participants" or "Transmission Owners") own the Joint Participation Project ("JPP") as set forth in the Participation Agreement, amended by Amendment No. 1;

WHEREAS, APS acts as the Operating Agent of the JPP pursuant to the Participation Agreement, as amended;

~~WHEREAS, CAISO exercises Operational Control over the CAISO Controlled Grid; and~~

WHEREAS, APS and the CAISO are parties to the Interconnected Control Area Operating Agreement, dated November 26, 1997;

~~WHEREAS, the Participating TO owns, operates, and maintains the Participating TO's Transmission System; and~~

WHEREAS, APS, IID, SDG&E, and the CAISO provide transmission service on their respective Transmission Systems;

WHEREAS, Interconnection Customer intends to own, lease and/or control and operate the Generating Facility identified as a Large Generating Facility in Appendix C to this ~~LGIA;~~ and Agreement;

WHEREAS, NextLight, submitted an Interconnection Request for such Large Generating Facility to APS on February 22, 2008, and also submitted an Interconnection Request for Phase A of the Large Generating Facility to CAISO on June 2, 2008; ~~Customer, Participating TO, and CAISO~~

WHEREAS, NextLight and APS, on behalf of the Joint Participants, entered into an Engineering & Procurement Agreement dated March 30, 2010, to begin design and procurement work for certain Interconnection Facilities to be constructed pursuant to this Agreement and NextLight duly assigned the Engineering & Procurement Agreement to Agua Caliente Solar, LLC;

WHEREAS, the Parties have agreed to enter into this LGIA Agreement for the purpose of interconnecting the Large Generating Facility with the Participating TO's Transmission System; JPP; and

WHEREAS, all Parties that are public utilities subject to the jurisdiction of the Federal Energy Regulatory Commission ("FERC") will file this Agreement simultaneously, as a service agreement under their respective Tariffs.

NOW, THEREFORE, in consideration of and subject to the mutual covenants contained herein, it is agreed:

When used in this ~~LGIA Agreement,~~ terms with initial capitalization that are not defined in Article 1 shall have the meanings specified in the Article in which they are used or in the APS Open Access Transmission Tariff or the CAISO Tariff, as applicable.

When an Article of this Agreement contains the phrase "THIS ARTICLE IS NOT APPLICABLE TO THIS AGREEMENT," or "THIS SECTION IS NOT APPLICABLE TO THIS AGREEMENT," or "THIS PARAGRAPH IS NOT APPLICABLE TO THIS AGREEMENT," or when an Appendix to this Agreement contains the phrase "THIS APPENDIX IS NOT APPLICABLE TO THIS AGREEMENT," the Article, Section, Paragraph or Appendix will have no force and effect with respect to this Agreement.

ARTICLE 1. DEFINITIONS

Article 1. Definitions

Adverse System Impact shall mean the negative effects due to technical or operational limits on conductors or equipment being exceeded that may compromise the safety and reliability of the electric system.

Affected System shall mean an electric system other than the ~~CAISO Controlled Grid~~ APS or SDG&E's Transmission Systems or IID's share of the JPP that may be affected by the proposed interconnection, ~~including the Participating TO's electric system that is not part of the CAISO Controlled Grid.~~

Affected System Operator shall mean the entity that operates an Affected System.

Affected System Construction and Operation Agreement shall mean an agreement between the Interconnection Customer and IID to pay the costs of Network Upgrades, for either of the Project Phases, to IID's Transmission System, other than IID's share of the JPP, and to provide for repayment of amounts advanced to IID with transmission rate credits when transmission service is taken on IID's Transmission System.

Affected System Study shall mean an engineering study that evaluates the impacts of the proposed interconnection of either Project Phase on the safety and reliability of the Transmission System owned by IID, other than IID's share of the JPP, and provides a list of facilities that are required as a result of proposed interconnection, along with an estimate of cost responsibility and time to construct. This Affected System Study may be performed, at IID's option, either serially or in a cluster.

Affected System Study Agreement shall mean an agreement between the Interconnection Customer and IID whereby IID will perform and Interconnection Customer will pay the costs of an Affected System Study. The total costs will be pro rated to the extent IID performs the Affected System Study in a cluster for multiple generators seeking to interconnect to the CAISO controlled grid, with Interconnection Customer allocated a proportionate share of the total costs.

Affiliate shall mean, with respect to a corporation, partnership or other entity, each such other corporation, partnership or other entity that directly or indirectly, through one or more intermediaries, controls, is controlled by, or is under common control with, such corporation, partnership or other entity.

Ancillary Services shall mean those services that are necessary to support the transmission of capacity and energy from resources to loads while maintaining reliable operation of the Transmission System in accordance with Good Utility Practice.

Applicable Laws and Regulations shall mean all duly promulgated applicable federal, state and local laws, regulations, rules, ordinances, codes, decrees, judgments, directives, or judicial or administrative orders, permits and other duly authorized actions of any Governmental Authority.

Applicable Reliability Council shall mean the Western Electricity Coordinating Council or its successor.

Applicable Reliability Standards shall mean the requirements and guidelines of NERC, the Applicable Reliability Council, and the applicable Balancing Authority ~~Area of the Participating TO's Transmission System to which the Generating Facility is directly connected, including requirements adopted pursuant to Section 215 of the Federal Power Act.~~

Balancing Authority shall mean the responsible entity that integrates resource plans ahead of time, maintains load-interchange-generation balance within a Balancing Authority Area, and supports ~~Interconnection~~interconnection frequency in real time.

Balancing Authority Area shall mean the collection of generation, transmission, and loads within the metered boundaries of the Balancing Authority. The Balancing Authority maintains load- resource balance within this area.

Base Case shall mean the base case power flow, short circuit, and stability data bases used for the Interconnection Studies- by APS, the CAISO and its designees, or Interconnection Customer.

Breach shall mean the failure of a Party to perform or observe any material term or condition of this ~~LGIA~~Agreement.

Breaching Party shall mean a Party that is in Breach of this ~~LGIA~~Agreement.

Business Day shall mean Monday through Friday, excluding ~~federal holidays~~Federal Holidays and the day after Thanksgiving Day.

~~**CAISO Controlled Grid** shall mean the system of transmission lines and associated facilities of the parties to the Transmission Control Agreement that have been placed under the CAISO's Operational Control.~~

~~**CAISO Tariff** shall mean the CAISO's tariff, as filed with FERC, and as amended or supplemented from time to time, or any successor tariff.~~

Calendar Day shall mean any day including Saturday, Sunday or a ~~federal holiday~~Federal Holiday.

CAISO Interconnection Service shall have the meaning set forth in Article 4.1.1.

Clustering shall mean the process whereby a group of Interconnection Requests is studied together, instead of serially, for the purpose of conducting the Interconnection System Impact Study.

Commercial Operation shall mean the status of ~~an Electric Generating Unit or project phase~~a Project Block at a Generating Facility that has commenced generating electricity for sale, excluding electricity generated during Trial Operation.

Commercial Operation Date ~~of an Electric Generating Unit or project phase~~ shall mean the date on which the ~~Electric Generating Unit or project phase at the Generating Facility commences Commercial Operation as agreed to by the applicable Participating TO, the CAISO, and the~~ Interconnection Customer ~~pursuant to~~ declares completion of all Project Blocks within a Project Phase, as described in Appendix E to this LGIA Agreement and in accordance with the implementation plan agreed to by the ~~Participating TO and the CAISO~~ Parties for multiple ~~individual Electric Generating Units or project phases at a Generating Facility where an Interconnection Customer intends to establish separate Commercial Operation Dates for those Electric Generating Units or project phases~~ Project Blocks at the Generating Facility.

Confidential Information shall mean any confidential, proprietary or trade secret information of a plan, specification, pattern, procedure, design, device, list, concept, policy or compilation relating to the present or planned business of a Party, which is designated as confidential by the Party supplying the information, whether conveyed orally, electronically, in writing, through inspection, or otherwise, subject to Article 22.1.2.

Default shall mean the failure of a Breaching Party to cure its Breach in accordance with Article 17 of this LGIA Agreement.

Dispute Resolution shall mean the procedure for resolution of a dispute between the Parties in which they will first attempt to resolve the dispute on an informal basis.

Distribution System shall mean ~~those non-CAISO-controlled transmission and distribution facilities owned by the Participating TO~~ each of the respective facilities and equipment of APS, IID or SDG&E used to transmit electricity to ultimate usage points such as homes and industries directly from nearby generators or from interchanges with higher voltage transmission networks which transport bulk power over longer distances. The voltage levels at which distribution systems operate differ among areas.

Distribution Upgrades shall mean the additions, modifications, and upgrades to the ~~Participating TO's~~ Distribution System at or beyond the Point of Interconnection to facilitate interconnection of the Generating Facility and render the transmission service necessary to effect Interconnection Customer's wholesale sale of electricity in interstate commerce. Distribution Upgrades do not include Interconnection Facilities.

Effective Date shall mean the date on which this LGIA Agreement becomes effective upon execution by ~~all the~~ Parties subject to acceptance by FERC, or if filed unexecuted pursuant to Section 205 of the Federal Power Act, upon the date specified by FERC, ~~for those Parties which are FERC-jurisdictional public utilities; provided, however, that, as applied to IID, the~~ Effective Date of this Agreement shall not commence until the Agreement is actually executed by IID, either voluntarily or pursuant to a lawful order issued by FERC in accordance with Sections 210 and 212 of the Federal Power Act.

~~**Electric Generating Unit** shall mean an individual electric generator and its associated plant and apparatus whose electrical output is capable of being separately identified and metered.~~

Emergency Condition shall mean a condition or situation: (1) that in the judgment of the Party making the claim is imminently likely to endanger life or property; or (2) that, in the case of a Transmission Owner or the CAISO, ~~is imminently likely (as determined in a non-discriminatory manner) to cause a material adverse effect on the security of, or damage to, the CAISO Controlled Grid or the electric systems of others to which the CAISO Controlled Grid is directly connected;~~ (3) that, in the case of the Participating TO, is imminently likely (as determined in a non-discriminatory manner) to cause a material adverse effect on the security of, or damage to, ~~the Participating TO's Transmission System, Participating TO's its Transmission System, its Interconnection Facilities, Distribution System, or the electric systems of others to which the Participating TO's electric system is directly connected;~~ or (4) that, in the case of the Interconnection Customer, is imminently likely (as determined in a non-discriminatory manner) to cause a material adverse effect on the security of, or damage to, ~~or the electric systems of others to which its Transmission System is directly connected;~~ or (3) that, in the case of Interconnection Customer, is imminently likely (as determined in a non-discriminatory manner) to cause a material adverse effect on the security of, or damage to, the Generating Facility or Interconnection Customer's Interconnection Facilities. System restoration and black start shall be considered Emergency Conditions; provided, that Interconnection Customer is not obligated by this LGIA Agreement to possess black start capability.

Energy Resource Interconnection Service shall mean an Interconnection Service that allows the Interconnection Customer to connect its Generating Facility to the APS Transmission System and IID's share of the JPP to be eligible to deliver the Generating Facility's electric output using the existing firm or nonfirm capacity of the APS Transmission System and IID's share of the JPP on an as available basis. Energy Resource Interconnection Service in and of itself does not convey transmission service.

Engineering & Procurement (E&P) Agreement shall mean an agreement between NextLight and APS, on behalf of the Transmission Owners pursuant to the Participation Agreement, to begin engineering and procurement of long lead-time items necessary for the establishment of the interconnection in order to advance the implementation of the Interconnection Requests for Phase A of the Interconnection Project, which has been duly assigned to Agua Caliente Solar, LLC.

Environmental Law shall mean Applicable Laws or Regulations relating to pollution or protection of the environment or natural resources.

Federal Power Act shall mean the Federal Power Act, as amended, 16 U.S.C. §§ 791a et seq.

FERC shall mean the Federal Energy Regulatory Commission or its successor.

Force Majeure shall mean any act of God, labor disturbance, act of the public enemy, war, insurrection, riot, fire, storm or flood, earthquake, explosion, breakage or accident to machinery or equipment, any order, regulation or restriction imposed by governmental, military or lawfully established civilian authorities, or any other cause beyond a Party's control. A Force

Majeure event does not include acts of negligence or intentional wrongdoing by the Party claiming Force Majeure.

Generating Facility shall mean ~~the~~ Interconnection Customer's **Electric-Generating Unit(s)-used** ~~device~~ for the production of electricity identified in the Interconnection ~~Customer's Interconnection~~ Request(s), but shall not include the Interconnection Customer's Interconnection Facilities. The Generating Facility consists of Phase A of the Generating Facility and Phase B of the Generating Facility.

Generating Facility Capacity shall mean the net capacity of the Generating Facility and the aggregate net capacity of the Generating Facility where it includes multiple energy production devices.

Good Utility Practice shall mean any of the practices, methods and acts engaged in or approved by a significant portion of the electric utility industry during the relevant time period, or any of the practices, methods and acts which, in the exercise of reasonable judgment in light of the facts known at the time the decision was made, could have been expected to accomplish the desired result at a reasonable cost consistent with good business practices, reliability, safety and expedition. Good Utility Practice is not intended to be any one of a number of the optimum practices, methods, or acts to the exclusion of all others, but rather to be acceptable practices, methods, or acts generally accepted in the region.

Governmental Authority shall mean any federal, state, local or other governmental, regulatory or administrative agency, court, commission, department, board, or other governmental subdivision, legislature, rulemaking board, tribunal, or other governmental authority having jurisdiction over the Parties, their respective facilities, or the respective services they provide, and exercising or entitled to exercise any administrative, executive, police, or taxing authority or power; provided, however, that such term does not include ~~the~~ Interconnection Customer, Transmission Owners, the CAISO, ~~Participating TO~~, or any Affiliate thereof.

Hazardous Substances shall mean any chemicals, materials or substances defined as or included in the definition of "hazardous substances," "hazardous wastes," "hazardous materials," "hazardous constituents," "restricted hazardous materials," "extremely hazardous substances," "toxic substances," "radioactive substances," "contaminants," "pollutants," "toxic pollutants" or words of similar meaning and regulatory effect under any applicable Environmental Law, or any other chemical, material or substance, exposure to which is prohibited, limited or regulated by any applicable Environmental Law.

Initial Synchronization Date shall mean the date upon which **an Electric Generating Unit** the first Project Block of a Project Phase is initially synchronized and upon which Trial Operation begins.

In-Service Date shall mean the date upon which the Interconnection Customer reasonably expects it will be ready to begin use of the ~~Participating TO's~~ Transmission Owners' Interconnection Facilities to obtain back feed power.

Interconnection Customer shall mean Agua Caliente Solar LLC, to which NextLight has duly assigned its Interconnection Requests for Phase A of the Generating Facility, and North

Gila River Development, LLC, to which NextLight has duly assigned its Interconnection Request submitted only to APS for Phase B of the Generating Facility, and their successors and assigns.

Interconnection Customer's Interconnection Facilities shall mean all facilities and equipment, as identified in ~~Appendix A~~ Appendices A-1 and A-2 of this ~~LGIA~~ Agreement, that are located between the Generating Facility and the Point of Change of Ownership, including any modification, addition, or upgrades to such facilities and equipment necessary to physically and electrically interconnect the Generating Facility to the ~~Participating TO's Transmission System~~ JPP. Interconnection Customer's Interconnection Facilities are sole use facilities.

Interconnection Facilities shall mean the ~~Participating TO's~~ Transmission Owners' Interconnection Facilities and the Interconnection Customer's Interconnection Facilities. Collectively, Interconnection Facilities include all facilities and equipment between the Generating Facility and the Point of Interconnection, including any modification, additions or upgrades that are necessary to physically and electrically interconnect the Generating Facility to the ~~Participating TO's Transmission System~~ JPP. Interconnection Facilities are sole use facilities and shall not include Distribution Upgrades, Stand Alone Network Upgrades or Network Upgrades.

Interconnection Facilities Study shall mean a study conducted by APS or a third party consultant for the Interconnection Customer to determine a list of facilities (including Transmission Owners' Interconnection Facilities and Network Upgrades to the JPP as identified in the Interconnection System Impact Study), the cost of those facilities, and the time required to interconnect the Generating Facility with the JPP; the scope of the study is defined in Section 8 of the APS Large Generator Interconnection Procedures.

Interconnection Feasibility Study shall mean a preliminary evaluation of the system impact and cost of interconnecting the Generating Facility to the JPP, the scope of which is described in Section 6 of the APS Large Generator Interconnection Procedures.

Interconnection Financial Security shall have the meaning assigned to it in Section 1.2 of the ~~LGIP~~ CAISO's Large Generator Interconnection Procedures.

~~Interconnection Handbook shall mean a handbook, developed by the Participating TO and posted on the Participating TO's web site or otherwise made available by the Participating TO, describing technical and operational requirements for wholesale generators and loads connected to the Participating TO's portion of the CAISO Controlled Grid, as such handbook may be modified or superseded from time to time. Participating TO's standards contained in the Interconnection Handbook shall be deemed consistent with Good Utility Practice and Applicable Reliability Standards. In the event of a conflict between the terms of this LGIA and the terms of the Participating TO's Interconnection Handbook, the terms in this LGIA shall apply.~~

Interconnection Request shall mean a request, in the form of Appendix 1 to the Large Generator Interconnection Procedures, in accordance with the ~~CAISO Tariff~~ APS or CAISO Tariffs, to interconnect a new Generating Facility, or to increase the capacity of, or make a Material Modification to the operating characteristics of, an existing Generating Facility that is

interconnected with the JPP. The Interconnection Customer made an Interconnection Request to APS for both Phase A of the Generating Facility and Phase B of the Generating Facility and an Interconnection Request to the CAISO only for Phase A of the Generating Facility. The Interconnection Customer did not make an Interconnection Request to IID.

Interconnection Service shall mean the service provided by the ~~Participating TO~~ Transmission Owners and the CAISO associated with interconnecting the Interconnection Customer's Generating Facility to the ~~Participating TO's Transmission System~~ JPP and enabling ~~the CAISO Controlled Grid~~ them to receive electric energy and capacity from the Generating Facility at the Point of Interconnection, pursuant to the terms of this ~~LGIA, the Participating TO's Transmission Owner Tariff~~ Agreement and the Tariffs of APS, IID, SDG&E, and the CAISO ~~Tariff~~.

Interconnection Study shall mean ~~either~~ any of the following studies: (1) the Interconnection Feasibility Study, the Interconnection System Impact Study, or the Interconnection Facilities Study described in the APS Large Generator Interconnection Procedures; or (2) the Phase I Interconnection Study or the Phase II Interconnection Study conducted or caused to be performed by the CAISO, in coordination with the applicable Participating TO(s), pursuant to the ~~described in the CAISO~~ Large Generator Interconnection Procedures.

Interconnection System Impact Study shall mean an engineering study that evaluates the impact of the proposed interconnection on the safety and reliability of Transmission Owners' Transmission Systems and, if applicable, an Affected System. The study shall identify and detail the system impacts that would result if the Generating Facility were interconnected without project modifications or system modifications, focusing on the Adverse System Impacts identified in the Interconnection Feasibility Study, or to study potential impacts, including but not limited to those identified in the Scoping Meeting as described in the APS Large Generator Interconnection Procedures.

Interconnection System Impact Study Agreement shall mean the form of agreement contained in the Large Generator Interconnection Procedures of APS for conducting an Interconnection System Impact Study.

IRS shall mean the Internal Revenue Service.

Joint Operating Committee shall be a group made up of representatives from Interconnection Customer and APS, on behalf of the Transmission Owners, to coordinate operating and technical considerations of Interconnection Service.

Joint Participation Project (JPP) shall mean the transmission facilities jointly owned by APS, IID and SDG&E pursuant to the Arizona Transmission System Participation Agreement, as amended.

Large Generating Facility shall mean a Generating Facility having a Generating Facility Capacity of more than 20 MW.

Large Generator Interconnection Procedures (LGIP) shall mean the ~~CAISO protocol that sets forth the~~ interconnection procedures applicable to an Interconnection

Request pertaining to a Large Generating Facility that ~~is included~~ are included in the APS or the CAISO Tariff. With respect to the Interconnection Request made to the CAISO for Phase A of the Generating Facility, the applicable LGIP is the LGIP for Interconnection Requests in a Queue Cluster Window, which is found in CAISO Tariff Appendix Y.

~~Large Generator Interconnection Study Process Agreement shall mean the agreement between the Interconnection Customer and the CAISO for the conduct of the Interconnection Studies.~~

Loss shall mean any and all damages, losses, and claims, including claims and actions relating to injury to or death of any person or damage to property, demand, suits, recoveries, costs and expenses, court costs, attorney fees, and all other obligations by or to third parties.

Material Modification shall mean those modifications that have a material impact on the cost or timing of any Interconnection Request or any other valid interconnection request with a later queue priority date.

Metering Equipment shall mean all metering equipment installed or to be installed for measuring the output ~~of~~ at the Generating Facility pursuant to this ~~LGIA Agreement~~ at the metering points, including but not limited to instrument transformers, MWh-meters, data acquisition equipment, transducers, remote terminal unit, communications equipment, phone lines, and fiber optics.

NERC shall mean the North American Electric Reliability ~~Council~~ Corporation or its successor organization.

Network Resource shall mean any designated generating resource owned, purchased, or leased by a Network Customer under the APS Network Integration Transmission Service Tariff, or the IID Open Access Transmission Tariff. Network Resources do not include any resource, or any portion thereof, that is committed for sale to third parties or otherwise cannot be called upon to meet the Network Customer's Network Load on a non-interruptible basis.

Network Resource Interconnection Service shall mean an Interconnection Service that allows an interconnection customer to integrate its Large Generating Facility with the APS Transmission System or IID's share of the JPP in a manner comparable to that in which APS or IID integrates its generating facilities to serve native load customers. Network Resource Interconnection Service in and of itself does not convey transmission service.

~~Network Upgrades shall be Participating TO's Delivery Network Upgrades and Participating TO's Reliability Network Upgrades.~~

~~Operational Control shall mean the rights of the CAISO under the Transmission Control Agreement and the CAISO Tariff to direct the parties to the Transmission Control Agreement how to operate their transmission lines and facilities and other electric plant affecting the reliability of those lines and facilities for the purpose of affording comparable non-discriminatory transmission access and meeting applicable reliability criteria.~~

~~**Participating TO's Delivery Network Upgrades** shall mean the additions, modifications, and upgrades to the Participating TO Transmission Owners' and CAISO's Transmission System at or beyond the Point of Interconnection, other than Reliability Network Upgrades, identified in the Interconnection Studies, as identified in Appendix A, to relieve constraints on the CAISO Controlled Grid Systems required at or beyond the point at which the Interconnection Facilities connect to the JPP to accommodate the interconnection of the Large Generating Facility to the Transmission Owners' and the CAISO's Transmission Systems.~~

~~**Participating TO's Interconnection Facilities** shall mean all facilities and equipment owned, controlled or operated by the Participating TO from the Point of Change of Ownership to the Point of Interconnection as identified in Appendix A to this LGIA, including any modifications, additions or upgrades to such facilities and equipment. Participating TO's Interconnection Facilities are sole-use facilities and shall not include Distribution Upgrades, Stand Alone Network Upgrades or Network Upgrades.~~

Notice of Dispute shall mean a written notice of a dispute or claim that arises out of or in connection with this Agreement or its performance.

~~**Participating TO's Reliability Network Upgrades** shall mean the additions, modifications, and upgrades to the Participating TO's Transmission System at or beyond the Point of Interconnection, identified in the Interconnection Studies, as identified in Appendix A, necessary to interconnect the Large Generating Facility safely and reliably to the Participating TO's Transmission System, which would not have been necessary but for the interconnection of the Large Generating Facility, including additions, modifications, and upgrades necessary to remedy short circuit or stability problems resulting from the interconnection of the Large Generating Facility to the Participating TO's Transmission System. Participating TO's Reliability Network Upgrades also include, consistent with Applicable Reliability Standards and Applicable Reliability Council practice, the Participating TO's facilities necessary to mitigate any adverse impact the Large Generating Facility's interconnection may have on a path's Applicable Reliability Council rating. Participating TO's Reliability Network Upgrades do not include any Participating TO's Delivery Network Upgrades.~~

~~**Participating TO's Transmission System** shall mean the facilities owned and operated by the Participating TO and that have been placed under the CAISO's Operational Control, which facilities form part of the CAISO Controlled Grid.~~

Operating Agent of the JPP shall mean APS as the entity designated as the operating agent of the JPP pursuant to the Participation Agreement.

Ownership Interests shall mean the ownership interests of APS, IID and SDG&E in the JPP, as set forth in the Participation Agreement, as amended, and for purposes of this Agreement, APS, 11 percent; IID, 12.78 percent; and SDG&E, 76.22 percent.

Party or Parties shall mean Transmission Owner(s), the ~~Participating TO~~, CAISO, Interconnection Customer or the applicable combination of the above.

Phase I Interconnection Study shall have the meaning set forth in the CAISO Tariff as of the effective date of this Agreement.

~~Phase I Interconnection Study shall mean the engineering study conducted or caused to be performed by the CAISO, in coordination with the applicable Participating TO(s), that evaluates the impact of the proposed interconnection on the safety and reliability of the Participating TO's Transmission System and, if applicable, an Affected System. The study shall identify and detail the system impacts that would result if the Generating Facility(ies) were interconnected without identified project modifications or system modifications, as provided in the On-Peak Deliverability Assessment (as defined in the CAISO Tariff), and other potential impacts, including but not limited to those identified in the Scoping Meeting as described in the Large Generator Interconnection Procedures. The study will also identify the approximate total costs, based on per unit costs, of mitigating these impacts, along with an equitable allocation of those costs to Interconnection Customers for their individual Generating Facilities.~~

Phase II Interconnection Study shall have the meaning set forth in the CAISO Tariff as of the effective date of this Agreement.

~~Phase II Interconnection Study shall mean an engineering and operational study conducted or caused to be performed by the CAISO once per calendar year, in coordination with the applicable Participating TO(s), to determine the Point of Interconnection and a list of facilities (including the Participating TO's, Network Upgrades, Distribution Upgrades, and Stand Alone Network Upgrades), the cost of those facilities, and the time required to interconnect the Generating Facility(ies) with the Participating TO's Transmission System~~

Phase A of the Generating Facility shall mean no more than 290 MW (net) of solar photovoltaic units installed at the site of the Generating Facility, as described in Appendix C.

Phase B of the Generating Facility shall mean no more than 210 MW (net) of solar photovoltaic units installed at the site of the Generating Facility, as described in Appendix C, after Phase A of the Generating Facility has been completed.

Phase A of the Interconnection Project shall mean construction of the Interconnection Facilities and Network Upgrades required to interconnect Phase A of the Generating Facility, as described in Appendix A-1.

Phase B of the Interconnection Project shall mean construction of the Interconnection Facilities and Network Upgrades required to interconnect Phase B of the Generating Facility, as described in Appendices A-2 and A-3 and as may be identified in studies provided for in Appendix C.

Point of Change of Ownership shall mean the point, as set forth in ~~Appendix A~~Appendices A-1 and A-2 to this ~~LGIA Agreement~~, where the Interconnection Customer's Interconnection Facilities connect to the ~~Participating TO's~~Transmission Owners' Interconnection Facilities.

Point of Interconnection shall mean the point, as set forth in ~~Appendix A~~Appendices A-1 and A-2 to this ~~LGIA Agreement~~, where the Interconnection Facilities connect to the ~~Participating TO's Transmission System~~JPP.

Project Block shall mean a portion of the solar photovoltaic units within a Project Phase as described in Appendix B-1 and B-2.

Project Phase shall mean either Phase A of the Generating Facility or Phase B of the Generating Facility.

~~QF PGA shall mean a Qualifying Facility Participating Generator Agreement specifying the special provisions for the operating relationship between a Qualifying Facility and the CAISO, a pro forma version of which is set forth in Appendix B.3 of the CAISO Tariff.~~

~~Qualifying Facility shall mean a qualifying cogeneration facility or qualifying small power production facility, as defined in the Code of Federal Regulations, Title 18, Part 292 (18 C.F.R. §292).~~

Queue Position shall mean the order of a valid Interconnection Request, relative to all other pending valid Interconnection Requests, that is established based upon the date and time of receipt of the valid Interconnection Request by APS or the CAISO under its Tariff.

Reasonable Efforts shall mean, with respect to an action required to be attempted or taken by a Party under this ~~LGIA Agreement~~, efforts that are timely and consistent with Good Utility Practice and are otherwise substantially equivalent to those a Party would use to protect its own interests.

Scoping Meeting shall mean the ~~meeting among~~meetings between representatives of the Interconnection Customer, ~~the Participating TO(s), other Affected Systems, and~~ Transmission Owners and the CAISO conducted for the purpose of discussing alternative interconnection options, to exchange information including any transmission data and earlier study evaluations that would be reasonably expected to impact such interconnection options, to analyze such information, and to determine the potential feasible Points of Interconnection.

Site Control shall mean documentation reasonably demonstrating: (1) ownership of, a leasehold interest in, or a right to develop a site for the purpose of constructing the Generating

Facility; (2) an option to purchase or acquire a leasehold site for such purpose; or (3) an exclusivity or other business relationship between Interconnection Customer and the entity having the right to sell, lease or grant Interconnection Customer the right to possess or occupy a site for such purpose.

Small Generating Facility shall mean a Generating Facility that has a Generating Facility Capacity of no more than 20 MW.

Stand Alone Network Upgrades shall mean Network Upgrades that ~~the~~an Interconnection Customer may construct without affecting day-to-day operations of the ~~CAISO Controlled Grid or Affected Systems~~Transmission System during their construction. The ~~Participating TO~~Transmission Owners, the CAISO, and the Interconnection Customer must agree as to what constitutes Stand Alone Network Upgrades and identify them in ~~Appendix A~~Appendices A-1, A-2, and A-3 to this ~~LGIA~~Agreement.

System Protection Facilities shall mean the equipment, including necessary protection signal communications equipment, that protects (1) the ~~Participating TO~~Transmission Owners' and the CAISO's ~~Transmission System, Participating TO's Interconnection Facilities, CAISO Controlled Grid, and Affected~~ Systems from faults or other electrical disturbances occurring at the Generating Facility and (2) the Generating Facility from faults or other electrical system disturbances occurring on the ~~Transmission Owners' and the CAISO Controlled Grid, Participating TO's Interconnection Facilities, and Affected's~~ Transmission Systems or on other delivery systems or other generating systems to which the ~~CAISO Controlled Grid is~~Transmission Owners' and the CAISO's Transmission Systems are directly connected.

Tariff shall mean the APS, IID, SDG&E or CAISO tariffs through which open access transmission service and Interconnection Service are offered, as filed with FERC with respect to FERC-jurisdictional public utilities and as posted with respect to IID, and as amended or supplemented from time to time, or any successor tariff.

~~**Transmission Control Agreement** shall mean CAISO FERC Electric Tariff No. 7.~~

Transmission Owner(s) shall mean APS, IID and SDG&E, as joint owners of the JPP at the Point of Interconnection. Pursuant to the Participation Agreement, APS is Operating Agent of the JPP and acts on behalf of the Transmission Owners with respect to the JPP.

Transmission Owners' Interconnection Facilities shall mean all facilities and equipment owned, controlled or operated by the Transmission Owners from the Point of Change of Ownership identified in Appendices A-1 and A-2 to the Point of Interconnection as identified in Appendices A-1 and A-2 to this Agreement, including any modifications, additions or upgrades to such facilities and equipment. Transmission Owners' Interconnection Facilities are sole use facilities and shall not include Distribution Upgrades, Stand Alone Network Upgrades or Network Upgrades.

Transmission System shall mean the facilities, including the portion of the JPP, owned, controlled or operated by Transmission Owner or the CAISO that are used to provide transmission service under the respective Tariff.

Trial Operation shall mean the period during which ~~the~~ Interconnection Customer is engaged in on-site test operations and commissioning of ~~an Electric Generating Unit~~ the first Project Block of each Project Phase prior to Commercial Operation.

ARTICLE 2. EFFECTIVE DATE, TERM AND TERMINATION

Article 2. Effective Date, Term, and Termination

- 2.1 Effective Date.** ~~This LGIA~~ Except as provided below with respect to IID, this Agreement shall become effective upon execution by ~~all the~~ Parties ~~subject to and~~ acceptance for filing by FERC ~~(if applicable)~~, or if filed unexecuted under Section 205 of the Federal Power Act, upon the date specified by FERC. ~~The CAISO and Participating TO shall promptly file~~ for the Transmission Owners that are FERC-jurisdictional public utilities and the CAISO. Such Transmission Owners and the CAISO shall promptly submit this LGIA Agreement for filing with FERC upon execution in accordance with Article 3.1, if required. ~~3.1. The Parties acknowledge that IID is not a public utility subject to FERC's jurisdiction under Section 205 or 206 of the Federal Power Act. Therefore, as applied to IID, the Effective Date for the Agreement shall not commence until the later of the date the Agreement is executed by IID, either voluntarily or pursuant to a lawful order issued by FERC in accordance with Sections 210 and 212 of the Federal Power Act, and the date the Agreement is accepted for filing with regard to the Transmission Owners that are FERC-jurisdictional and the CAISO.~~
- 2.2 Term of Agreement.** Subject to the provisions of Article 2.3, this LGIA Agreement shall remain in effect for a period of ~~_____~~ forty (40) years from the Effective Date ~~(Term Specified in Individual Agreements to be ten (10) years or such other longer period as the Interconnection Customer may request)~~ and shall be automatically renewed for each successive one-year period thereafter.
- 2.3 Termination Procedures.**
- 2.3.1 Written Notice.** This LGIA Agreement may be terminated by ~~the (i)~~ Interconnection Customer after giving ~~the CAISO and the Participating TO~~ all other Parties ninety (90) Calendar Days advance written notice, or ~~by (ii)~~ by APS, on behalf of the Transmission Owners, or the CAISO ~~and the Participating TO~~ notifying FERC after the Generating Facility permanently ceases Commercial Operation. Notice of termination by the Interconnection Customer must be provided by both of the entities comprising the Interconnection Customer.
- 2.3.2 Default.** A Party may terminate this LGIA Agreement in accordance with Article 17.
- 2.3.3 ~~Suspension of Work.~~** ~~This LGIA may be deemed terminated in accordance with Article 5.16.~~

~~2.3.4~~ Notwithstanding Articles ~~2.3.1, 2.3.1 and~~ 2.3.2, ~~and 2.3.3~~, no termination shall become effective until the Parties have complied with all Applicable Laws and Regulations applicable to such termination, including ~~the any required~~ filing with FERC of a notice of termination of this ~~LGIA (if applicable) Agreement~~, which notice has been accepted for filing by FERC, ~~and the Interconnection Customer has fulfilled its termination cost obligations under Article 2.4.~~ For clarity and avoidance of ambiguity, IID is not a jurisdictional public utility required to file a notice of termination under Section 205 or 206 of the Federal Power Act prior to terminating its participation in this Agreement in accordance with the terms of such Agreement.

2.4 Termination Costs ~~Immediately upon the other Parties'~~

Upon receipt of a notice of the termination of this ~~LGIA Agreement~~ pursuant to Article 2.3 above, the ~~CAISO Transmission Owners~~ and the ~~Participating TO CAISO~~ will promptly determine the total cost responsibility of the Interconnection Customer. If, as of the date of ~~the other Parties'~~ receipt of ~~the such~~ notice of termination, the Interconnection Customer has not already paid its share of Network Upgrade costs, ~~as set forth in Appendix G to this LGIA, the Participating TO will liquidate the including those set forth in Appendices A-1, A-2, and A-3, APS, as the Operating Agent of the JPP, will enforce the financial security rights of APS and IID pursuant to this Agreement and SDG&E will cause~~ Interconnection Customer's Interconnection Financial Security associated with its cost responsibility for SDG&E's non-JPP Network Upgrades and SDG&E's share of the JPP Network Upgrades set forth in Appendices A-1, A-2, and A-3 to be liquidated, in accordance with Section 9.4 of the ~~LGIP CAISO's~~ Large Generator Interconnection Procedures.

The Interconnection Customer will also be responsible for all costs incurred or irrevocably committed to be incurred in association with the construction of the ~~Participating TO's Transmission Owners'~~ Interconnection Facilities (including any cancellation costs relating to orders or contracts for Interconnection Facilities and equipment) and other such expenses, ~~including any Distribution Upgrades~~ for which the ~~Participating TO Transmission Owners~~ or the CAISO ~~has have~~ incurred expenses or ~~has have~~ irrevocably committed to incur expenses and ~~has have~~ not been reimbursed by the Interconnection Customer, as of the date of ~~the other Parties'~~ receipt of the notice of termination, subject to the limitations set forth in this Article 2.4. Nothing in this Article 2.4 shall limit the Parties' rights under Article 17. If, as of the date of the ~~other Parties'~~ receipt of the notice of termination, the Interconnection Customer has not already reimbursed the ~~Participating TO Transmission Owners~~ and the CAISO for costs incurred to construct the ~~Participating TO's Transmission Owners'~~ Interconnection Facilities, ~~the Participating TO APS, as Operating Agent of the JPP, shall enforce the financial security rights of APS and IID pursuant to this Agreement and SDG&E~~ will liquidate the Interconnection Customer's Interconnection Financial Security associated with the construction of ~~the Participating TO's SDG&E's share of the Transmission Owners'~~ Interconnection Facilities, in

accordance with Section 9.4 of the ~~LGIP~~CAISO Large Generator Interconnection Procedures.

For cost responsibility for Interconnection Facilities and Network Upgrades to the JPP set forth in Appendices A-1 and A-2, the Transmission Owners' financial security rights shall be enforced in accordance with the provisions for enforcement of financial security set forth in Appendices A-1 and A-2.

If the amount of the financial security, including the Interconnection Financial Security, liquidated by ~~the Participating TO~~Transmission Owners under this Article 2.4 is insufficient to compensate Transmission Owners and the CAISO ~~and the Participating TO~~ for actual costs associated with the construction of the ~~Participating TO's~~Transmission Owners' Interconnection Facilities and Network Upgrades contemplated in this Article, any additional amounts will be the responsibility of the Interconnection Customer, ~~subject to the provisions of Section 9.4 of the LGIP~~. Any such additional amounts due from the Interconnection Customer beyond the amounts covered by its financial security, including its Interconnection Financial Security, will be due to the ~~Participating TO~~Transmission Owners immediately upon termination of this ~~LGIA in accordance with Section 9.4 of the LGIP~~. Agreement, subject, with respect to amounts due SDG&E, to the provisions of Section 9.4 of the CAISO Large Generator Interconnection Procedures.

If the amount of the Interconnection Financial Security exceeds the Interconnection Customer's cost responsibility under Section 9.4 of the ~~LGIP, any~~CAISO's Large Generator Interconnection Procedures, such excess amount will be released to the Interconnection Customer by SDG&E in accordance with Section 9.4 of the ~~LGIP~~.CAISO's Large Generator Interconnection Procedures.

2.4.1 Notwithstanding the foregoing, in the event of termination ~~by a Party, all of this~~ Agreement, the Parties shall use commercially Reasonable Efforts to mitigate the costs, damages and charges arising as a consequence of termination. Upon termination of this Agreement, unless otherwise ordered or approved by FERC to the extent FERC possesses jurisdiction over the public utilities which are Parties to this Agreement:

2.4.1 With respect to any portion of ~~the Participating TO's~~Transmission Owners' Interconnection Facilities that have not yet been constructed or installed, ~~the Participating TO~~Transmission Owners shall to the extent possible and with ~~the~~ Interconnection Customer's authorization cancel any pending orders of, or return, any materials or equipment for, or contracts for construction of, such ~~facilities~~Interconnection Facilities; provided that in the event ~~the~~ Interconnection Customer elects not to authorize such cancellation, ~~the~~ Interconnection Customer shall assume all payment obligations with respect to such materials, equipment, and contracts, and ~~the Participating TO~~Transmission Owners shall deliver such material and equipment, and, if necessary, assign such contracts, to ~~the~~ Interconnection Customer as soon as practicable, at ~~the~~ Interconnection Customer's expense. To the extent that ~~the~~ Interconnection Customer has already paid ~~the Participating TO~~Transmission

Owners for any or all such costs of materials or equipment not taken by ~~the~~ Interconnection Customer, ~~the Participating TO~~ Transmission Owners shall promptly refund such amounts to ~~the~~ Interconnection Customer, less any costs, including penalties, incurred by ~~the Participating TO~~ Transmission Owners to cancel any pending orders of or return such materials, equipment, or contracts.

2.4.2 ~~The Participating TO~~ Transmission Owners may, at ~~its~~ their collective option, retain any portion of such materials, equipment, or facilities that ~~the~~ Interconnection Customer chooses not to accept delivery of, in which case ~~the Participating TO~~ Transmission Owners shall be responsible for all costs associated with procuring such materials, equipment, or facilities.

2.4.3 With respect to any portion of the Interconnection Facilities, and any other facilities already installed or constructed pursuant to the terms of this LGIA Agreement, Interconnection Customer shall be responsible for all costs associated with the removal, relocation or other disposition or retirement of such materials, equipment, or facilities.

~~2.5 — Disconnection.~~

2.5 Disconnection. Upon termination of this Agreement as to Phase A of the Interconnection Project, APS, on behalf of Transmission Owners, will take all appropriate steps to disconnect Phase A of the Interconnection Project from the JPP. All costs required to effectuate such disconnection shall be borne by the terminating Party, unless such termination resulted from the non-terminating Party's Default of this Agreement or such non-terminating Party otherwise is responsible for these costs under this Agreement.

Upon termination of this LGIA, the Parties Agreement as to Phase B of the Interconnection Project, APS, on behalf of Transmission Owners will take all appropriate steps to disconnect ~~the Large Generating Facility from the Participating TO's Transmission System~~ Phase B of the Interconnection Project from the JPP. All costs required to effectuate such disconnection shall be borne by the terminating Party, unless such termination resulted from the non-terminating Party's Default of this LGIA Agreement or such non-terminating Party otherwise is responsible for these costs under this LGIA Agreement.

2.6 **Survival.** This LGIA Agreement shall continue in effect after termination to the extent necessary to provide for final billings and payments and for costs incurred hereunder, including billings and payments pursuant to this LGIA Agreement; to permit the determination and enforcement of liability and indemnification obligations arising from acts or events that occurred while this LGIA Agreement was in effect; and to permit ~~each Party~~ the Parties to have access to the lands of ~~the other Parties~~ another Party pursuant to this LGIA Agreement or other applicable agreements, to disconnect, remove or salvage its own facilities and equipment.

~~ARTICLE 3. REGULATORY FILINGS AND CAISO TARIFF COMPLIANCE~~ Article 3. Regulatory Filings

3.1 **Filing.** The ~~Participating TO and the~~ CAISO and Transmission Owners that are FERC-jurisdictional public utilities shall file this LGIA Agreement (and any amendment hereto) with the appropriate Governmental Authority(ies), if required. ~~The~~ Interconnection Customer may request that any information so provided be subject to the confidentiality provisions of Article 22. If ~~the~~ Interconnection Customer has executed this LGIA Agreement, or any amendment thereto, ~~the~~ Interconnection Customer shall reasonably cooperate with ~~the Participating TO and~~ Transmission Owners and the CAISO with respect to such filing and to provide any information reasonably requested by Transmission Owners and ~~the Participating TO or~~ CAISO needed to comply with applicable regulatory requirements. For clarity and avoidance of ambiguity, IID is not a jurisdictional public utility subject to a filing requirement under Section 205 of the Federal Power Act.

~~3.2 Agreement Subject to CAISO Tariff.~~ ~~The Interconnection Customer will comply with all applicable provisions of the CAISO Tariff, including the LGIP.~~

~~3.3 Relationship Between this LGIA and the CAISO Tariff.~~ ~~With regard to rights and obligations between the Participating TO and the Interconnection Customer, if and to the extent a matter is specifically addressed by a provision of this LGIA (including any appendices, schedules or other attachments to this LGIA), the provisions of this LGIA shall govern. If and to the extent a provision of this LGIA is inconsistent with the CAISO Tariff and dictates rights and obligations between the CAISO and the Participating TO or the CAISO and the Interconnection Customer, the CAISO Tariff shall govern.~~

~~3.4 Relationship Between this LGIA and the QF PGA.~~ ~~With regard to the rights and obligations of a Qualifying Facility that has entered into a QF PGA with the CAISO and has entered into this LGIA, if and to the extent a matter is specifically addressed by a provision of the QF PGA that is inconsistent with this LGIA, the terms of the QF PGA shall govern.~~

~~ARTICLE 4. SCOPE OF SERVICE~~

Article 4. Scope of Service

4.1 **Interconnection Service.** ~~Interconnection Service~~ Product Options. Interconnection Customer has selected Energy Resource Interconnection Service from APS to interconnect to the APS Transmission System and IID's share of the JPP, and Interconnection Service from the CAISO.

4.1.1 CAISO Interconnection Service. Interconnection Service provided by the CAISO and SDG&E allows the Interconnection Customer to connect the Large Generating Facility to the ~~Participating TO~~ CAISO's Transmission System and be eligible to deliver the Large Generating Facility's output using the available capacity of the CAISO ~~Controlled Grid.~~ ~~To the extent the~~

~~Interconnection Customer wants to receive Interconnection Service, the Participating TO shall construct facilities identified in Appendices A and C that the Participating TO is responsible to construct.~~ s Transmission System pursuant to the CAISO Tariff.

Interconnection Service does not necessarily provide the Interconnection Customer with the capability to physically deliver the output of its Large Generating Facility to any particular load on the CAISO ~~Controlled Grid~~ Transmission System without incurring congestion costs. In the event of transmission constraints on the CAISO ~~Controlled Grid~~ Transmission System, the Interconnection Customer's Large Generating Facility shall be subject to the applicable congestion management procedures in the CAISO Tariff in the same manner as all other resources.

4.1.2 Energy Resource Interconnection Service.

4.1.2.1 The Product. Energy Resource Interconnection Service from APS and IID allows Interconnection Customer to connect the Large Generating Facility to the JPP and be eligible to deliver the Large Generating Facility's output using available capacity on the existing firm or non-firm capacity of the APS Transmission System and IID's share of the JPP on an "as available" basis.

4.1.2.2 Transmission Delivery Service Implications. Under Energy Resource Interconnection Service, Interconnection Customer will be eligible to inject power from the Large Generating Facility into and deliver power across the APS Transmission System and IID's share of the JPP on an "as available" basis up to the amount of MWs identified in the applicable stability and steady state studies to the extent the upgrades initially required to qualify for Energy Resource Interconnection Service have been constructed. No transmission delivery service from the Large Generating Facility is assured, but Interconnection Customer may obtain Point-to-Point Transmission Service, Network Integration Transmission Service, or be used for secondary network transmission service, pursuant to the APS Tariff or Transmission Service on IID's share of the JPP pursuant to the IID Tariff, up to the maximum output identified in the stability and steady state studies. In order for Interconnection Customer to obtain the right to deliver or inject energy beyond the Large Generating Facility Point of Interconnection or to improve its ability to do so, transmission delivery service must be obtained pursuant to the provisions of the APS or IID Tariffs. The Interconnection Customer's ability to inject its Large Generating Facility output beyond the Point of Interconnection, therefore, will depend on the existing capacity of the APS or IID Transmission Systems at such time as a transmission service request is made that would accommodate such delivery. The provision of firm Point-to-Point Transmission Service or Network Integration Transmission Service may require the construction of additional Network Upgrades.

4.1.3 Network Resource Interconnection Service.

4.1.3.1 The Product. [THIS SECTION IS NOT APPLICABLE TO THIS AGREEMENT.]

4.1.3.2 Transmission Delivery Service Implications. [THIS SECTION IS NOT APPLICABLE TO THIS AGREEMENT.]

- 4.2 **Provision of Service.** ~~The Participating TO~~ APS, on behalf of the Transmission Owners, and the CAISO shall provide Interconnection Service for the Large Generating Facility at the Point of Interconnection.
- 4.3 **Performance Standards.** Each Party shall perform all of its obligations under this LGIA Agreement in accordance with Applicable Laws and Regulations, Applicable Reliability Standards, and Good Utility Practice, and to the extent a Party is required or prevented or limited in taking any action by such regulations and standards, such Party shall not be deemed to be in Breach of this LGIA Agreement for its compliance therewith. If such Party is a Transmission Owner or the CAISO ~~or Participating TO,~~ then that Party shall ~~amend the LGIA and~~ negotiate an amendment to the Agreement and, if it is a FERC-jurisdictional public utility, shall submit the amendment to FERC for approval. For clarity and avoidance of ambiguity, IID is not a FERC-jurisdictional public utility subject to a filing requirement under Section 205 of the Federal Power Act.
- 4.4 **No Transmission Delivery Service.** The execution of this LGIA Agreement does not constitute a request for, nor the provision of, any transmission delivery service under ~~the CAISO~~ any applicable Tariff, and does not convey any right to deliver electricity to any specific customer or point of delivery.
- 4.5 **Interconnection Customer Provided Services.** The services provided by Interconnection Customer under this LGIA Agreement are set forth in Article 9.6 and Article 13.5.1. Interconnection Customer shall be paid for such services in accordance with Article 11.6.

**~~ARTICLE 5. INTERCONNECTION FACILITIES ENGINEERING,
PROCUREMENT, AND CONSTRUCTION~~**

~~Interconnection Facilities, Network Upgrades, and Distribution Upgrades shall be studied, designed, and constructed pursuant to Good Utility Practice. Such studies, design and construction shall be based on the assumed accuracy and completeness of all technical information received by the Participating TO and the CAISO from the Interconnection Customer associated with interconnecting the Large Generating Facility.~~

Article 5. Interconnection Facilities Engineering, Procurement, and Construction

5.1 Options. Unless otherwise mutually agreed ~~amongto between~~ the Parties, ~~the~~ Interconnection Customer shall select the In-Service Date, Initial Synchronization Date, and Commercial Operation Date; and either Standard Option or Alternate Option set forth below for completion of ~~the Participating TO's~~ Transmission Owners' Interconnection Facilities and Network Upgrades as set forth in ~~Appendix A, Interconnection Facilities, Network Upgrades, and Distribution Upgrades,~~ Appendices A-1, A-2, and A-3, and such dates and selected option shall be set forth in ~~Appendix B,~~ Appendices B-1, B-2, and B-3 Milestones.

5.1.1 Standard Option. ~~The Participating TO~~ APS, on behalf of Transmission Owners shall design, procure, and construct ~~the Participating TO's~~ Transmission Owners' Interconnection Facilities, ~~Network Upgrades, and Distribution Upgrades,~~ and JPP Network Upgrades set forth in Appendices A-1 and A-2, and SDG&E shall design, procure, and construct Network Upgrades set forth in Appendix A-3, in each case using Reasonable Efforts to complete the Participating TO's Transmission Owners' Interconnection Facilities, ~~and these~~ Network Upgrades, and Distribution Upgrades by the dates set forth in ~~Appendix B,~~ Appendices B-1, B-2, and B-3 Milestones. ~~The Participating TO~~ Transmission Owners shall not be required to undertake any action which is inconsistent with ~~its~~ their standard safety practices, ~~its~~ material and equipment specifications, ~~its~~ design criteria and construction procedures, ~~its~~ labor agreements, and Applicable Laws and Regulations. In the event ~~the Participating TO~~ APS, on behalf of Transmission Owners, and/or SDG&E, as applicable, reasonably ~~expects~~ expect that ~~it~~ they will not be able to complete ~~the Participating TO's~~ Transmission Owners' Interconnection Facilities, ~~and~~ Network Upgrades, and Distribution Upgrades set forth in Appendices A-1, A-2, and A-3 by the specified dates, ~~the Participating TO~~ in the Appendices B-1, B-2, and B-3 Milestones, APS, on behalf of Transmission Owners, and/or SDG&E, as applicable, shall promptly provide written notice to ~~the~~ Interconnection Customer and ~~the CAISO and~~ shall undertake Reasonable Efforts to meet the earliest dates thereafter.

~~**5.1.2 Alternate Option.** If the dates designated by the Interconnection Customer are acceptable to the Participating TO, the Participating TO shall so notify the Interconnection Customer within thirty (30) Calendar Days, and shall assume responsibility for the design, procurement and construction of the Participating TO's Interconnection Facilities by the designated dates.~~

~~If the Participating TO subsequently fails to complete the Participating TO's Interconnection Facilities by the In-Service Date, to the extent necessary to provide back feed power; or fails to complete Network Upgrades by the Initial Synchronization Date to the extent necessary to allow for Trial Operation at full power output, unless other arrangements are made by the Parties for such Trial Operation; or fails to complete the Network Upgrades by the~~

~~Commercial Operation Date, as such dates are reflected in Appendix B, Milestones; the Participating TO shall pay the Interconnection Customer liquidated damages in accordance with Article 5.3, Liquidated Damages, provided, however, the dates designated by the Interconnection Customer shall be extended day for day for each day that the CAISO refuses to grant clearances to install equipment.~~

~~5.1.2 **Alternate Option.** [THIS SECTION IS NOT APPLICABLE TO THIS AGREEMENT.]~~

~~**5.1.3 Option to Build.** If the dates designated by the Interconnection Customer are not acceptable to the Participating TO, the Participating TO shall so notify the Interconnection Customer within thirty (30) Calendar Days, and unless the Parties agree otherwise, the Interconnection Customer shall have the option to assume responsibility for the design, procurement and construction of the Participating TO's Interconnection Facilities and Stand Alone Network Upgrades. If the Interconnection Customer elects to exercise its option to assume responsibility for the design, procurement and construction of the Participating TO's Interconnection Facilities and Stand Alone Network Upgrades, it shall so notify the Participating TO within thirty (30) Calendar Days of receipt of the Participating TO's notification that the designated dates are not acceptable to the Participating TO. The Participating TO, CAISO, and Interconnection Customer must agree as to what constitutes Stand Alone Network Upgrades and identify such Stand Alone Network Upgrades in Appendix A to this LGIA. Except for Stand Alone Network Upgrades, the Interconnection Customer shall have no right to construct Network Upgrades under this option.~~

~~5.1.3 **Option to Build.** [THIS SECTION IS NOT APPLICABLE TO THIS AGREEMENT.]~~

~~**5.1.4 Negotiated Option.** If the Interconnection Customer elects not to exercise its option under Article 5.1.3, Option to Build, the Interconnection Customer shall so notify the Participating TO within thirty (30) Calendar Days of receipt of the Participating TO's notification that the designated dates are not acceptable to the Participating TO, and the Parties shall in good faith attempt to negotiate terms and conditions (including revision of the specified dates and liquidated damages, the provision of incentives or the procurement and construction of a portion of the Participating TO's Interconnection Facilities and Stand Alone Network Upgrades by the Interconnection Customer) pursuant to which the Participating~~

~~TO is responsible for the design, procurement and construction of the Participating TO's Interconnection Facilities and Network Upgrades. If the Parties are unable to reach agreement on such terms and conditions, the Participating TO shall assume responsibility for the design, procurement and construction of the Participating TO's Interconnection Facilities and Network Upgrades pursuant to Article 5.1.1, Standard Option.~~

~~5.1.4 Negotiated Option. [THIS SECTION IS NOT APPLICABLE TO THIS AGREEMENT.]~~

5.2 General Conditions Applicable to Option to Build. ~~If the Interconnection Customer assumes responsibility for the design, procurement and construction of the Participating TO's Interconnection Facilities and Stand Alone Network Upgrades,~~

~~(1) the Interconnection Customer shall engineer, procure equipment, and construct the Participating TO's Interconnection Facilities and Stand Alone Network Upgrades (or portions thereof) using Good Utility Practice and using standards and specifications provided in advance by the Participating TO;~~

~~(2) The Interconnection Customer's engineering, procurement and construction of the Participating TO's Interconnection Facilities and Stand Alone Network Upgrades shall comply with all requirements of law to which the Participating TO would be subject in the engineering, procurement or construction of the Participating TO's Interconnection Facilities and Stand Alone Network Upgrades;~~

~~(3) the Participating TO shall review, and the Interconnection Customer shall obtain the Participating TO's approval of, the engineering design, equipment acceptance tests, and the construction of the Participating TO's Interconnection Facilities and Stand Alone Network Upgrades, which approval shall not be unreasonably withheld, and the CAISO may, at its option, review the engineering design, equipment acceptance tests, and the construction of the Participating TO's Interconnection Facilities and Stand Alone Network Upgrades;~~

~~(4) prior to commencement of construction, the Interconnection Customer shall provide to the Participating TO, with a copy to the CAISO for informational purposes, a schedule for construction of the Participating TO's Interconnection Facilities and Stand Alone Network Upgrades, and shall promptly respond to requests for information from the Participating TO;~~

~~(5) at any time during construction, the Participating TO shall have the right to gain unrestricted access to the Participating TO's Interconnection Facilities and Stand Alone Network Upgrades and to conduct inspections of the same;~~

~~(6) at any time during construction, should any phase of the engineering, equipment procurement, or construction of the Participating TO's Interconnection Facilities and Stand Alone Network Upgrades not meet the standards and specifications provided by the Participating TO, the Interconnection Customer shall be obligated to remedy deficiencies in that portion of the Participating TO's Interconnection Facilities and Stand Alone Network Upgrades;~~

~~(7) the Interconnection Customer shall indemnify the CAISO and Participating TO for claims arising from the Interconnection Customer's construction of the Participating TO's Interconnection Facilities and Stand Alone Network Upgrades under the terms and procedures applicable to Article 18.1 Indemnity;~~

~~(8) The Interconnection Customer shall transfer control of the Participating TO's Interconnection Facilities to the Participating TO and shall transfer Operational Control of Stand Alone Network Upgrades to the CAISO;~~

~~(9) Unless the Parties otherwise agree, the Interconnection Customer shall transfer ownership of the Participating TO's Interconnection Facilities and Stand Alone Network Upgrades to the Participating TO. As soon as reasonably practicable, but within twelve months after completion of the construction of the Participating TO's Interconnection Facilities and Stand Alone Network Upgrades, the Interconnection Customer shall provide an invoice of the final cost of the construction of the Participating TO's Interconnection Facilities and Stand Alone Network Upgrades to the Participating TO, which invoice shall set forth such costs in sufficient detail to enable the Participating TO to reflect the proper costs of such facilities in its transmission rate base and to identify the investment upon which refunds will be provided;~~

~~(10) the Participating TO shall accept for operation and maintenance the Participating TO's Interconnection Facilities and Stand Alone Network Upgrades to the extent engineered, procured, and constructed in accordance with this Article 5.2; and~~

~~(11) The Interconnection Customer's engineering, procurement and construction of the Participating TO's Interconnection Facilities and Stand-Alone Network Upgrades shall comply with all requirements of the "Option to Build" conditions set forth in Appendix C. Interconnection Customer shall deliver to the Participating TO "as-built" drawings, information, and any other documents that are reasonably required by the Participating TO to assure that the Interconnection Facilities and Stand-Alone Network Upgrades are built to the standards and specifications required by the Participating TO.~~

~~[\[THIS SECTION IS NOT APPLICABLE TO THIS AGREEMENT.\]](#)~~

~~**5.3—Liquidated Damages.** The actual damages to the Interconnection Customer, in the event the Participating TO's Interconnection Facilities or Network Upgrades are not completed by the dates designated by the Interconnection Customer and accepted by the Participating TO pursuant to subparagraphs 5.1.2 or 5.1.4, above, may include Interconnection Customer's fixed operation and maintenance costs and lost opportunity costs. Such actual damages are uncertain and impossible to determine at this time. Because of such uncertainty, any liquidated damages paid by the Participating TO to the Interconnection Customer in the event that the Participating TO does not complete any portion of the Participating TO's Interconnection Facilities or Network Upgrades by the applicable dates, shall be an amount equal to ½ of 1 percent per day of the actual cost of the Participating TO's Interconnection Facilities and Network Upgrades, in the aggregate, for which the Participating TO has assumed responsibility to design, procure and construct.~~

~~However, in no event shall the total liquidated damages exceed 20 percent of the actual cost of the Participating TO's Interconnection Facilities and Network Upgrades for which the Participating TO has assumed responsibility to design, procure, and construct. The foregoing payments will be made by the Participating TO to the Interconnection Customer as just compensation for the damages caused to the Interconnection Customer, which actual damages are uncertain and impossible to determine at this time, and as reasonable liquidated damages, but not as a penalty or a method to secure performance of this LGIA. Liquidated damages, when the Parties agree to them, are the exclusive remedy for the Participating TO's failure to meet its schedule.~~

~~No liquidated damages shall be paid to the Interconnection Customer if: (1) the Interconnection Customer is not ready to commence use of the Participating TO's Interconnection Facilities or Network Upgrades to take the delivery of power for the Electric Generating Unit's Trial Operation or to export power from the Electric Generating Unit on the specified dates, unless the Interconnection Customer would have been able to commence~~

~~use of the Participating TO's Interconnection Facilities or Network Upgrades to take the delivery of power for Electric Generating Unit's Trial Operation or to export power from the Electric Generating Unit, but for the Participating TO's delay; (2) the Participating TO's failure to meet the specified dates is the result of the action or inaction of the Interconnection Customer or any other interconnection customer who has entered into an interconnection agreement with the CAISO and/or Participating TO, action or inaction by the CAISO, or any cause beyond the Participating TO's reasonable control or reasonable ability to cure; (3) the Interconnection Customer has assumed responsibility for the design, procurement and construction of the Participating TO's Interconnection Facilities and Stand Alone Network Upgrades; or (4) the Parties have otherwise agreed.~~

~~In no event shall the CAISO have any responsibility or liability to the Interconnection Customer for liquidated damages pursuant to the provisions of this Article 5.3.~~

5.3 Liquidated Damages. [THIS SECTION IS NOT APPLICABLE TO THIS AGREEMENT.]

5.4 Power System Stabilizers. ~~The~~If the Applicable Reliability Standards, or the guidelines and procedures established by the Applicable Reliability Council, deem a Power System Stabilizer applicable to the type of solar photovoltaic equipment used in the Generating Facility, then the Interconnection Customer shall procure, install, maintain and operate Power System Stabilizers ~~in accordance with Applicable Reliability Standards, the guidelines and procedures established by the Applicable Reliability Council, and the provisions of Section 4.6.5.1 of the CAISO Tariff.~~ The CAISO, APS reserves the right to reasonably establish ~~reasonable~~ minimum acceptable settings for any installed Power System Stabilizers, subject to the design and operating limitations of the Large Generating Facility. If the Large Generating Facility's Power System Stabilizers are removed from service or not capable of automatic operation, ~~the~~ Interconnection Customer shall immediately notify ~~the CAISO and the Participating TO~~APS and restore the Power System Stabilizers to operation as soon as possible. ~~The CAISO~~APS shall have the right to order the reduction in output or disconnection of the Large Generating Facility if the reliability of the ~~CAISO Controlled Grid~~Transmission System would be adversely affected as a result of improperly tuned Power System Stabilizers. ~~The requirements of this Article 5.4 shall not apply to wind generators of the induction type~~Generating Facility is a solar photovoltaic generator and as such does not have the physical characteristic to which a Power System Stabilizer would apply.

5.5 Equipment Procurement. ~~If responsibility for construction of the Participating TO's~~The Transmission Owners' design of Transmission Owners' Interconnection Facilities or ~~and~~ Network Upgrades is to be borne by the Participating TO, then the Participating TO shall commence design of the Participating TO's ~~to the JPP for Phase A of the Interconnection Project, as set forth in Appendix A-1, and partial procurement of certain long-lead equipment for Phase A of the Interconnection Project~~

has been advanced in accordance with the terms of the E & P Agreement dated March 30, 2010. To the extent the design and long lead time procurement work has not been completed pursuant to the E&P Agreement, APS, on behalf of Transmission Owners, shall finish design of Transmission Owners' Interconnection Facilities ~~or~~ and Network Upgrades to the JPP and procure necessary equipment ~~as soon as practicable after all of the following conditions are satisfied, unless the Parties otherwise agree in writing;~~ pursuant to the terms of this Agreement.

~~5.5.1 The CAISO, in coordination with the applicable Participating TO(s), has completed the Phase II Interconnection Study pursuant to the Large Generator Interconnection Facilities Study Process Agreement;~~

~~5.5.2 The Participating TO has received written authorization to proceed with design and procurement from the Interconnection Customer by the date specified in Appendix B, Milestones; and~~

~~5.5.3 The Interconnection Customer has provided security to the Participating TO in accordance with Article 11.5 by the dates specified in Appendix B, Milestones.~~

5.6 Construction Commencement. APS, on behalf of Transmission Owners, shall commence construction of Transmission Owners' Interconnection Facilities and Network Upgrades to the JPP for which it is responsible as set forth in Appendices A-1, and A-2, and SDG&E shall commence construction of Network Upgrades to its non-JPP facilities for which it is responsible as set forth in Appendix A-3, as soon as practicable after the following additional conditions are satisfied:

~~5.6 Construction Commencement. The Participating TO shall commence construction of the Participating TO's Interconnection Facilities and Network Upgrades for which it is responsible as soon as practicable after the following additional conditions are satisfied:~~

~~5.6.1 Approval of the appropriate Governmental Authority has been obtained for any facilities requiring regulatory approval;~~

~~5.6.2 Necessary real property rights and rights-of-way have been obtained, to the extent required for the construction of a discrete aspect of ~~the Participating TO's~~ Transmission Owners' Interconnection Facilities and Network Upgrades ~~set forth in Appendices A-1, A-2, and A-3;~~~~

~~5.6.3 ~~The Participating TO has~~ Transmission Owners have received written authorization to proceed with construction from ~~the~~ Interconnection Customer by the date specified in ~~Appendix B,~~ Appendices B-1, B-2, and B-3 Milestones; and~~

- 5.6.4 ~~The~~ Interconnection Customer has provided payment and security ~~to the Participating TO~~ in accordance with Article 11.5 by the dates specified in ~~Appendix B, Appendices B-1, B-2, and B-3~~, Milestones.
- 5.6.5 For Phase B of the Interconnection Project only, the conditions specified in Appendix C also shall be met before construction of Transmission Owners' Interconnection Facilities and Network Upgrades commences for that Project Phase.
- 5.7 **Work Progress.** The Parties will keep each other advised periodically as to the progress of their respective design, procurement and construction efforts. Any Party may, at any time, request a progress report from another Party. If, at any time, ~~the~~ Interconnection Customer determines that the completion of ~~the Participating TO's~~ Transmission Owners' Interconnection Facilities will not be required until after the specified In-Service Date, ~~the~~ Interconnection Customer will provide written notice to ~~the Participating TO APS, SDG&E, IID,~~ and the CAISO of such later date upon which the completion of ~~the Participating TO's~~ Transmission Owners' Interconnection Facilities will be required.
- 5.8 **Information Exchange.** As soon as reasonably practicable after the Effective Date, ~~the Parties~~ Transmission Owners, CAISO and the Interconnection Customer shall exchange information regarding the design and compatibility of the ~~Interconnection Customer's Interconnection Facilities and Participating TO's~~ Parties' Interconnection Facilities and compatibility of the Interconnection Facilities with ~~the Participating TO~~ Transmission Owners' and the CAISO's Transmission ~~System~~ Systems, and shall work diligently and in good faith to make any necessary design changes.
- 5.9 **Limited Operation.** If any of ~~the Participating TO's~~ Transmission Owners' Interconnection Facilities or Network Upgrades are not reasonably expected to be completed prior to the Commercial Operation Date of ~~the Electric Generating Unit, the Participating TO and/or a Project Phase, Transmission Owners and~~ CAISO, ~~as applicable,~~ shall, upon the request and at the expense of ~~the~~ Interconnection Customer, perform operating studies on a timely basis to determine the extent to which the ~~Electric~~ Large Generating ~~Unit~~ Facility and ~~the~~ Interconnection Customer's Interconnection Facilities may operate prior to the completion of ~~the Participating TO's~~ Transmission Owners' Interconnection Facilities or Network Upgrades consistent with Applicable Laws and Regulations, Applicable Reliability Standards, Good Utility Practice, and this ~~LGIA. The Participating TO Agreement.~~ Transmission Owners and CAISO shall permit Interconnection Customer to operate the ~~Electric Generating Unit and the Project Phase and~~ Interconnection Customer's Interconnection Facilities in accordance with the results of such studies.
- 5.10 **Interconnection Customer's Interconnection Facilities ('ICIF').** ~~The~~ Interconnection Customer shall, at its expense, design, procure, construct, own and install the ~~Interconnection Customer's Interconnection Facilities~~ ICIF, as set forth in ~~Appendix A- Appendices A-1 and A-2.~~

5.10.1 ~~Large Generating Facility and~~ Interconnection Customer's Interconnection Facilities Specifications. ~~In addition to the Interconnection Customer's responsibility to submit technical data with its Interconnection Request as required by Section 3.5.1 of the LGIP, the Facility Specifications.~~ Interconnection Customer shall submit ~~all remaining necessary~~ initial specifications for the ~~Interconnection Customer's Interconnection Facilities and Large Generating Facility~~ ICIF and a Project Phase, including System Protection Facilities, to ~~the Participating TO and the~~ (i) APS, on behalf of Transmission Owners, and (ii) CAISO at least one hundred eighty (180) Calendar Days prior to the Initial Synchronization Date for the Project Phase; and final specifications for review and comment at least ninety (90) Calendar Days prior to the Initial Synchronization Date. ~~The Participating TO and the~~ for the Project Phase. Transmission Owners and CAISO shall review such specifications ~~pursuant to this LGIA and the LGIP~~ to ensure that the ~~Interconnection Customer's Interconnection Facilities and~~ ICIF and Project Phase of Large Generating Facility are compatible with the technical specifications, operational control, and safety requirements, ~~and any other applicable requirements of the Participating TO and the~~ of Transmission Owners and CAISO and comment on such specifications within thirty (30) Calendar Days of ~~the~~ Interconnection Customer's submission. All specifications provided hereunder shall be deemed confidential.

5.10.2 ~~Participating TO's~~ Review by Transmission Owners and CAISO's Review. ~~The Participating TO's and the~~ Transmission Owners and CAISO's review of ~~the~~ Interconnection Customer's final specifications shall not be construed as confirming, endorsing, or providing a warranty as to the design, fitness, safety, durability or reliability of the Large Generating Facility, or the ~~Interconnection Customer's Interconnection Facilities~~ ICIF. Interconnection Customer shall make such changes to the ~~Interconnection Customer's Interconnection Facilities~~ ICIF as may reasonably be required by ~~the Participating TO or the~~ Transmission Owners or CAISO, in accordance with Good Utility Practice, to ensure that the ~~Interconnection Customer's Interconnection Facilities~~ ICIF are compatible with the technical specifications, ~~Operational Control~~ operational control, and safety requirements of ~~the Participating TO or the~~ Transmission Owners and CAISO.

5.10.3 ~~Interconnection Customer's Interconnection Facilities~~ ICIF Construction. The ~~Interconnection Customer's Interconnection Facilities~~ ICIF shall be designed and constructed in accordance with Good Utility Practice. Within one hundred twenty (120) Calendar Days after the Commercial Operation Date of a Project Phase, unless the ~~Participating TO and Interconnection Customer~~ Parties agree on another mutually acceptable deadline, ~~the~~ Interconnection Customer shall deliver to ~~the Participating TO~~

~~and (i) APS, on behalf of Transmission Owners, and (ii) CAISO “as-built” drawings, information and documents for the Interconnection Customer’s Interconnection Facilities and the Electric Generating Unit(s) ICIF and the applicable Project Phase of the Large Generating Facility, such as: a one-line diagram, a site plan showing the Large Generating Facility and the Interconnection Customer’s Interconnection Facilities ICIF, plan and elevation drawings showing the layout of the Interconnection Customer’s Interconnection Facilities ICIF, a relay functional diagram, relaying AC and DC schematic wiring diagrams and relay settings for all facilities associated with the Interconnection Customer’s step-up transformers, the facilities connecting the Large Generating Facility Project Phase to the step-up transformers and the Interconnection Customer’s Interconnection Facilities ICIF, and the impedances (determined by factory tests) for the associated step-up transformers and the Electric Generating Units Project Phase. The Interconnection Customer shall provide the Participating TO and the (i) APS, on behalf of Transmission Owners, and (ii) CAISO specifications for the excitation system, automatic voltage regulator, Large Generating Facility control and protection settings, transformer tap settings, and communications, if applicable. Any deviations from the relay settings, machine specifications, and other specifications originally submitted by the Interconnection Customer shall be assessed by the Participating TO Transmission Owners and the CAISO pursuant to the appropriate provisions of this LGIA Agreement and the LGIP APS and CAISO Large Generator Interconnection Procedures.~~

~~**5.10.4 Interconnection Customer to Meet Requirements of the Participating TO’s Interconnection Handbook. The Interconnection Customer shall comply with the Participating TO’s Interconnection Handbook.**~~

5.11 ~~Participating TO’s~~ Transmission Owners’ Interconnection Facilities

~~Construction. The Participating TO’s Transmission Owners’ Interconnection Facilities shall be designed and constructed in accordance with Good Utility Practice. Upon request, within one hundred twenty (120) Calendar Days after the Commercial Operation Date, unless the Participating TO and Interconnection Customer Parties agree on another mutually acceptable deadline, the Participating TO APS, on behalf of Transmission Owners, shall deliver to the Interconnection Customer and the CAISO the following “as-built” drawings, information and documents for the Participating TO’s Transmission Owners’ Interconnection Facilities [include, including appropriate drawings and relay diagrams].~~

~~The Participating TO APS, on behalf of Transmission Owners, will obtain control for operating and maintenance purposes of the Participating TO’s of Transmission Owners’ Interconnection Facilities and Stand Alone Network Upgrades to the JPP upon completion of such facilities. Pursuant to Article 5.2, the CAISO will obtain Operational Control of the Stand Alone Network Upgrades prior to the Commercial Operation Date.~~

- 5.12 Access Rights.** Upon reasonable notice and supervision by a Party, and subject to any required or necessary regulatory approvals, a Party (“Granting Party”) shall furnish at no cost to the other Party (“Access Party”) any rights of use, licenses, rights of way and easements with respect to lands owned or controlled by the Granting Party, its agents (if allowed under the applicable agency agreement), or any Affiliate, that are necessary to enable the Access Party to obtain ingress and egress to construct, operate, maintain, repair, test (or witness testing), inspect, replace or remove facilities and equipment to: (i) interconnect the Large Generating Facility with the ~~Participating TO’s Transmission System~~JPP; (ii) operate and maintain the Large Generating Facility, the Interconnection Facilities and the ~~Participating TO’s Transmission System~~JPP; and (iii) disconnect or remove the Access Party’s facilities and equipment upon termination of this LGIA Agreement. In exercising such licenses, rights of way and easements, the Access Party shall not unreasonably disrupt or interfere with normal operation of the Granting Party’s business and shall adhere to the safety rules and procedures established in advance, as may be changed from time to time, by the Granting Party and provided to the Access Party.
- 5.13 Lands of Other Property Owners.** If any part of ~~the Participating TO’s Transmission Owners’~~ Interconnection Facilities and/or Network Upgrades ~~are~~is to be installed on property owned by persons other than ~~the~~ Interconnection Customer or ~~Participating TO, the Participating TO Transmission Owners, Transmission Owners~~ shall at ~~the~~ Interconnection Customer’s expense use efforts, similar in nature and extent to those that ~~it~~they typically ~~undertakes~~undertake on ~~its~~their own behalf or on behalf of ~~its~~their Affiliates, including use of ~~its~~ eminent domain authority, and to the extent consistent with state law, to procure from such persons any rights of use, licenses, rights of way and easements that are necessary to construct, operate, maintain, test, inspect, replace or remove ~~the Participating TO’s Transmission Owners’~~ Interconnection Facilities and/or Network Upgrades upon such property.
- 5.14 Permits.** ~~Participating TO Transmission Owners~~ and Interconnection Customer shall cooperate with each other in good faith in obtaining all permits, licenses, and ~~authorization~~authorizations that are necessary to accomplish the interconnection in compliance with Applicable Laws and Regulations. With respect to this paragraph, ~~the Participating TO Transmission Owners~~ shall provide permitting assistance to ~~the~~ Interconnection Customer comparable to that provided to ~~the Participating TO’s Transmission Owners’~~ own, or an Affiliate’s generation.
- 5.15 Early Construction of Base Case Facilities.** ~~The~~ Interconnection Customer may request ~~the Participating TO Transmission Owners~~ to construct, and ~~the Participating TO Transmission Owners~~ shall construct, using Reasonable Efforts to accommodate Interconnection Customer’s In-Service Date, all or any portion of any Network Upgrades required for Interconnection Customer to be interconnected to the ~~Participating TO’s Transmission System~~JPP which are included in the Base Case of the Interconnection ~~Studies~~Facilities Study for ~~the~~ Interconnection Customer, and which also are required to be constructed for another interconnection customer, but where such construction is not scheduled to be completed in time to achieve Interconnection Customer’s In-Service Date.

5.16 Suspension. ~~The~~ Interconnection Customer reserves the right, upon written notice to ~~the Participating TO~~ APS, SDG&E, IID and the CAISO, to suspend at any time all work by APS and SDG&E associated with the construction and installation of ~~the Participating TO's~~ Transmission Owners' Interconnection Facilities, ~~Network Upgrades,~~ and/or Distribution Network Upgrades required under this LGIA Agreement, other than Network Upgrades, if any, identified in the Phase II Interconnection Study under the CAISO's Large Generator Interconnection Procedures as common to multiple Generating Facilities, with the condition that the ~~Participating TO's electrical system and the CAISO Controlled Grid~~ Transmission System shall be left in a safe and reliable condition in accordance with Good Utility Practice and ~~the Participating TO's~~ Transmission Owners' safety and reliability criteria, and the ~~CAISO's~~ Applicable Reliability Standards. In such event, ~~the~~ Interconnection Customer shall be responsible for all reasonable and necessary costs which ~~the Participating TO~~ Transmission Owners, (i) ~~has~~ have incurred pursuant to this LGIA Agreement prior to the suspension and (ii) ~~incurs~~ incur in suspending such work, including any costs incurred to perform such work as may be necessary to ensure the safety of persons and property and the integrity of the ~~Participating TO's electric system~~ Transmission System during such suspension and, if applicable, any costs incurred in connection with the cancellation or suspension of material, equipment and labor contracts which ~~the Participating TO~~ Transmission Owners cannot reasonably avoid; provided, however, that prior to canceling or suspending any such material, equipment or labor contract, ~~the Participating TO~~ Transmission Owners shall obtain Interconnection Customer's authorization to do so.

~~The Participating TO~~ APS, on behalf of Transmission Owners, with respect to facilities identified on Appendices A-1 and A-2, and SDG&E with respect to facilities identified on Appendix A-3, shall invoice ~~the~~ Interconnection Customer for such costs pursuant to Article 12 and shall use due diligence to minimize ~~its~~ such costs. In the event Interconnection Customer suspends work required under this LGIA Agreement pursuant to this Article 5.16, and has not requested ~~the Participating TO~~ APS, on behalf of Transmission Owners, or SDG&E to recommence the work or has not itself recommenced work required under this LGIA Agreement in time to ensure that ~~the new projected~~ Commercial Operation ~~Date for~~ of the full Generating Facility Capacity of the Large Generating Facility is no more than three (3) years from the final Commercial Operation Date identified in ~~Appendix B hereto, this LGIA~~ Appendices B-1, B-2, and B-3, this Agreement shall be deemed terminated and the Interconnection Customer's responsibility for costs of the Transmission Owners' Interconnection Facilities and Network Upgrades set forth in Appendices A-1, A-2, and A-3 will be determined in accordance with ~~Section 2.4 of this LGIA~~ Article 2.4. The suspension ~~period~~ shall begin on the date the suspension is requested, or the date of the written notice to ~~the Participating TO and the CAISO~~ APS, on behalf of Transmission Owners, for its work or SDG&E for its work, if no effective date is specified other than Network Upgrades, if any, identified in the Phase II Interconnection Study under the CAISO's Large Generator Interconnection Procedures.

5.17 Taxes.

5.17.1 Interconnection Customer Payments Not Taxable. The Parties intend that all payments or property transfers made by ~~the~~ Interconnection Customer to ~~the Participating TO~~ Transmission Owners for the installation of ~~the Participating TO's~~ Transmission Owners' Interconnection Facilities and the Network Upgrades shall be non-taxable, either as contributions to capital, or as a refundable advance, in accordance with the Internal Revenue Code and any applicable state income tax laws and shall not be taxable as contributions in aid of construction or otherwise under the Internal Revenue Code and any applicable state income tax laws.

5.17.2 Representations ~~And~~ Covenants. In accordance with IRS Notice 2001-82 and IRS Notice 88-129, ~~the~~ Interconnection Customer represents and covenants that (i) ownership of the electricity generated at the Large Generating Facility will pass to another party prior to the transmission of the electricity on ~~the CAISO Controlled Grid~~ a Transmission System, (ii) for income tax purposes, the amount of any payments and the cost of any property transferred to ~~the Participating TO for the Participating TO's~~ Transmission Owners for Transmission Owners' Interconnection Facilities will be capitalized by ~~the~~ Interconnection Customer as an intangible asset and recovered using the straight-line method over a useful life of twenty (20) years, and (iii) any portion of ~~the Participating TO's~~ Transmission Owners' Interconnection Facilities that is a "dual-use intertie," within the meaning of IRS Notice 88-129, is reasonably expected to carry only a de minimis amount of electricity in the direction of the Large Generating Facility. For this purpose, "de minimis amount" means no more than 5 percent of the total power flows in both directions, calculated in accordance with the "5 percent test" set forth in IRS Notice 88-129. This is not intended to be an exclusive list of the relevant conditions that must be met to conform to IRS requirements for non-taxable treatment.

At ~~the Participating TO~~ a Transmission Owner's request, ~~the~~ Interconnection Customer shall provide ~~the Participating TO~~ such Transmission Owner with a report from an independent engineer confirming its representation in clause (iii), above. ~~The Participating TO~~ Transmission Owners represents and ~~covenants~~ covenant that the cost of ~~the Participating TO's~~ Transmission Owners' Interconnection Facilities paid for by ~~the~~ Interconnection Customer ~~without the possibility of refund or credit~~ will have no net effect on the base upon which rates are determined.

~~5.17.3~~ 5.17.3 **Indemnification for the Cost ~~Consequence~~ Consequences of Current Tax Liability Imposed Upon the ~~Participating TO~~ Transmission Owner.**

Notwithstanding Article 5.17.1, ~~the~~ Interconnection Customer shall protect, indemnify and hold harmless ~~the Participating TO~~ each Transmission Owner from the cost consequences of any current tax liability imposed against ~~the Participating TO~~ a Transmission Owner as the result of payments or property transfers made by ~~the~~ Interconnection Customer to ~~the Participating TO~~ a Transmission Owner under this ~~LGIA~~ Agreement for Interconnection Facilities,

as well as any interest and penalties, other than interest and penalties attributable to any delay caused by ~~the Participating TO~~ a Transmission Owner.

~~The Participating TO~~ Transmission Owner shall not include a gross-up for the cost consequences of any current tax liability in the amounts it charges ~~the~~ Interconnection Customer under this LGIA Agreement unless (i) ~~the Participating TO~~ Transmission Owner has determined, in good faith, that the payments or property transfers made by ~~the~~ Interconnection Customer to ~~the Participating TO~~ Transmission Owner should be reported as income subject to taxation or (ii) any Governmental Authority directs ~~the Participating TO~~ Transmission Owner to report payments or property as income subject to taxation; provided, however, that ~~the Participating TO~~ Transmission Owner may require ~~the~~ Interconnection Customer to provide security for Interconnection Facilities, in a form reasonably acceptable to ~~the Participating TO~~ (such as a parental guarantee or a letter of credit) Transmission Owner, in an amount equal to the cost consequences of any current tax liability under this Article 5.17. ~~The~~ Interconnection Customer shall reimburse ~~the Participating TO~~ Transmission Owner for such costs on a fully grossed-up basis, in accordance with Article 5.17.4, within thirty (30) Calendar Days of receiving written notification from ~~the Participating TO~~ Transmission Owner of the amount due, including detail about how the amount was calculated.

The indemnification obligation shall terminate at the earlier of (1) the expiration of the ten year testing period and the applicable statute of limitation, as it may be extended by ~~the Participating TO~~ Transmission Owner upon request of the IRS, to keep these years open for audit or adjustment, or (2) the occurrence of a subsequent taxable event and the payment of any related indemnification obligations as contemplated by this Article 5.17.

- 5.17.4 Tax Gross-Up Amount.** ~~The~~ Interconnection Customer's liability for the cost consequences of any current tax liability under this Article 5.17 shall be calculated on a fully grossed-up basis. Except as may otherwise be agreed to by the parties, this means that ~~the~~ Interconnection Customer will pay ~~the Participating TO~~ Transmission Owner, in addition to the amount paid for the Interconnection Facilities and Network Upgrades, an amount equal to (1) the current taxes imposed on ~~the Participating TO~~ Transmission Owner ("Current Taxes") on the excess of (a) the gross income realized by ~~the Participating TO~~ Transmission Owner as a result of payments or property transfers made by ~~the~~ Interconnection Customer to ~~the Participating TO~~ Transmission Owner under this LGIA Agreement (without regard to any payments under this Article 5.17) (the "Gross Income Amount") over (b) the present value of future tax deductions for depreciation that will be available as a result of such payments or property transfers (the "Present Value Depreciation Amount"), plus (2) an additional amount sufficient to permit ~~the Participating TO~~ Transmission Owner to receive and retain, after the payment of all Current Taxes, an amount equal to the net amount described in clause (1).

For this purpose, (i) Current Taxes shall be computed based on ~~the Participating TO~~ Transmission Owner's composite federal and state tax rates at the time the payments or property transfers are received and ~~the Participating TO~~ Transmission Owner will be treated as being subject to tax at the highest marginal rates in effect at that time (the "Current Tax Rate"), and (ii) the Present Value Depreciation Amount shall be computed by discounting ~~the Participating TO~~ Transmission Owner's anticipated tax depreciation deductions as a result of such payments or property transfers by ~~the Participating TO~~ Transmission Owner's current weighted average cost of capital. Thus, the formula for calculating ~~the~~ Interconnection Customer's liability to ~~the Participating TO~~ each respective Transmission Owner pursuant to this Article 5.17.4 can be expressed as follows: $(\text{Current Tax Rate} \times (\text{Gross Income Amount} - \text{Present Value of Tax Depreciation})) / (1 - \text{Current Tax Rate})$. Interconnection Customer's estimated tax liability in the event taxes are imposed shall be stated in ~~Appendix A, Interconnection Facilities, Network Upgrades and Distribution Upgrades.~~ Appendices A-1, A-2, and A-3.

5.17.5 Private Letter Ruling or Change or Clarification of Law. At ~~the~~ Interconnection Customer's request and expense, ~~the Participating TO~~ Transmission Owner shall file with the IRS a request for a private letter ruling as to whether any property transferred or sums paid, or to be paid, by ~~the~~ Interconnection Customer to ~~the Participating TO~~ Transmission Owner under this LGIA Agreement are subject to federal income taxation. ~~The~~ Interconnection Customer will prepare the initial draft of the request for a private letter ruling, and will certify under penalties of perjury that all facts represented in such request are true and accurate to the best of ~~the~~ Interconnection Customer's knowledge. ~~The Participating TO~~ Transmission Owner and Interconnection Customer shall cooperate in good faith with respect to the submission of such request, ~~provided, however, the Interconnection Customer and the Participating TO explicitly acknowledge (and nothing herein is intended to alter) Participating TO's obligation under law to certify that the facts presented in the ruling request are true, correct and complete.~~

~~The Participating TO~~ Transmission Owner shall keep ~~the~~ Interconnection Customer fully informed of the status of such request for a private letter ruling and shall execute either a privacy act waiver or a limited power of attorney, in a form acceptable to the IRS, that authorizes ~~the~~ Interconnection Customer to participate in all discussions with the IRS regarding such request for a private letter ruling. ~~The Participating TO~~ Transmission Owner shall allow ~~the~~ Interconnection Customer to attend all meetings with IRS officials about the request and shall permit ~~the~~ Interconnection Customer to prepare the initial drafts of any follow-up letters in connection with the request.

5.17.6 Subsequent Taxable Events. If, within 10 years from the date on which the relevant ~~Participating TO~~ Transmission Owner's Interconnection Facilities are placed in service, (i) ~~the~~ Interconnection Customer Breaches the covenants

contained in Article 5.17.2, (ii) a "disqualification event" occurs within the meaning of IRS Notice 88-129, or (iii) this LGIA Agreement terminates and ~~the Participating TO~~ Transmission Owner retains ownership of the Interconnection Facilities and Network Upgrades, ~~the~~ Interconnection Customer shall pay a tax gross-up for the cost consequences of any current tax liability imposed on ~~the Participating TO~~ Transmission Owner, calculated using the methodology described in Article 5.17.4 and in accordance with IRS Notice 90-60.

5.17.7 Contests. In the event any Governmental Authority determines that ~~the Participating TO~~ a Transmission Owner's receipt of payments or property constitutes income that is subject to taxation, ~~the Participating TO~~ such Transmission Owner shall notify ~~the~~ Interconnection Customer, in writing, within thirty (30) Calendar Days of receiving notification of such determination by a Governmental Authority. Upon the timely written request by ~~the~~ Interconnection Customer and at ~~the~~ Interconnection Customer's sole expense, ~~the Participating TO~~ such Transmission Owner may appeal, protest, seek abatement of, or otherwise oppose such determination. Upon ~~the~~ Interconnection Customer's written request and sole expense, ~~the Participating TO~~ such Transmission Owner may file a claim for refund with respect to any taxes paid under this Article 5.17, whether or not it has received such a determination. ~~The Participating TO reserve~~ Such Transmission Owner reserves the right to make all decisions with regard to the prosecution of such appeal, protest, abatement or other contest, including the selection of counsel and compromise or settlement of the claim, but ~~the Participating TO~~ such Transmission Owner shall keep ~~the~~ Interconnection Customer informed, shall consider in good faith suggestions from ~~the~~ Interconnection Customer about the conduct of the contest, and shall reasonably permit ~~the~~ Interconnection Customer or an Interconnection Customer representative to attend contest proceedings.

~~The~~ Interconnection Customer shall pay to ~~the Participating TO~~ such Transmission Owner on a periodic basis, as invoiced by ~~the Participating TO, the Participating TO~~ Transmission Owner, Transmission Owner's documented reasonable costs of prosecuting such appeal, protest, abatement or other contest, ~~including any costs associated with obtaining the opinion of independent tax counsel described in this Article 5.17.7. The Participating TO may abandon any contest if the Interconnection Customer fails to provide payment to the Participating TO within thirty (30) Calendar Days of receiving such invoice.~~ At any time during the contest, ~~the Participating TO~~ such Transmission Owner may agree to a settlement either with ~~the~~ Interconnection Customer's consent or, ~~if such consent is refused,~~ after obtaining written advice from independent nationally-recognized tax counsel, selected by ~~the Participating TO~~ such Transmission Owner, but reasonably acceptable to ~~the~~ Interconnection Customer, that the proposed settlement represents a reasonable settlement given the hazards of litigation. ~~The~~ Interconnection Customer's obligation shall be

based on the amount of the settlement agreed to by ~~the~~ Interconnection Customer, or if a higher amount, so much of the settlement that is supported by the written advice from nationally-recognized tax counsel selected under the terms of the preceding ~~paragraph~~sentence. The settlement amount shall be calculated on a fully grossed-up basis to cover any related cost consequences of the current tax liability. ~~The Participating TO may also settle any tax controversy~~Any settlement without ~~receiving the~~ Interconnection Customer's consent or ~~any~~ such written advice; ~~however, any such settlement~~ will relieve ~~the~~ Interconnection Customer from any obligation to indemnify ~~the Participating TO~~such Transmission Owner for the tax at issue in the contest ~~(unless the failure to obtain written advice is attributable to the Interconnection Customer's unreasonable refusal to the appointment of independent tax counsel).~~

5.17.8 Refund. In the event that (a) a private letter ruling is issued to ~~the Participating TO~~a Transmission Owner which holds that any amount paid or the value of any property transferred by ~~the~~ Interconnection Customer to ~~the Participating TO~~such Transmission Owner under the terms of this LGIA Agreement is not subject to federal income taxation, (b) any legislative change or administrative announcement, notice, ruling or other determination makes it reasonably clear to ~~the Participating TO~~such Transmission Owner in good faith that any amount paid or the value of any property transferred by ~~the~~ Interconnection Customer to ~~the Participating TO~~such Transmission Owner under the terms of this LGIA Agreement is not taxable to ~~the Participating TO~~such Transmission Owner, (c) any abatement, appeal, protest, or other contest results in a determination that any payments or transfers made by ~~the~~ Interconnection Customer to ~~the Participating TO~~such Transmission Owner are not subject to federal income tax, or (d) if ~~the Participating TO~~such Transmission Owner receives a refund from any taxing authority for any overpayment of tax attributable to any payment or property transfer made by ~~the~~ Interconnection Customer to ~~the Participating TO~~such Transmission Owner pursuant to this LGIA, the Participating TO Agreement, such Transmission Owner shall promptly refund to ~~the~~ Interconnection Customer the following:

(i) any payment made by Interconnection Customer under this Article 5.17 to such Transmission Owner for taxes that is attributable to the amount determined to be non-taxable, together with interest thereon,

(ii) interest on any ~~amounts~~amount paid by ~~the~~ Interconnection Customer to ~~the Participating TO~~such Transmission Owner for such taxes which ~~the Participating TO~~Transmission Owner did not submit to the taxing authority, calculated in accordance with the methodology set forth in FERC's regulations at 18 C.F.R.CFR §35.19a(a)(2)(iii) from the date payment was made by ~~the~~ Interconnection Customer to the date ~~the Participating TO~~such Transmission Owner refunds such payment to ~~the~~ Interconnection Customer, and

(iii) with respect to any such taxes paid by ~~the Participating TO~~such Transmission Owner, any refund or credit ~~the Participating TO~~such Transmission Owner receives or to which it may be entitled from any Governmental Authority, interest (or that portion thereof attributable to the payment described in clause (i), above) owed to ~~the Participating TO~~such Transmission Owner for such overpayment of taxes (including any reduction in interest otherwise payable by ~~the Participating TO~~such Transmission Owner to any Governmental Authority resulting from an offset or credit); provided, however, that ~~the Participating TO~~such Transmission Owner will remit such amount promptly to ~~the Participating TO~~such Transmission Owner has received a tax refund, credit or offset from any Governmental Authority for any applicable overpayment of income tax related to ~~the Participating TO~~such Transmission Owner's Interconnection Facilities.

The intent of this provision is to leave the Parties, to the extent practicable, in the event that no taxes are due with respect to any payment for Transmission Owners' Interconnection Facilities and Network Upgrades hereunder, in the same position they would have been in had no such tax payments been made.

5.17.9 Taxes Other Than Income Taxes. Upon the timely request by ~~the~~ Interconnection Customer, and at ~~the~~ Interconnection Customer's sole expense, Transmission Owner or the CAISO ~~or Participating TO~~ may appeal, protest, seek abatement of, or otherwise contest any tax (other than federal or state income tax) asserted or assessed against Transmission Owner or the CAISO ~~or Participating TO~~ for which ~~the~~ Interconnection Customer may be required to reimburse Transmission Owner or the CAISO ~~or Participating TO~~ under the terms of this LGA Agreement. ~~The~~ Interconnection Customer shall pay to ~~the Participating TO~~Transmission Owner on a periodic basis, as invoiced by ~~the Participating TO, the Participating TO's~~Transmission Owner, Transmission Owners' documented reasonable costs of prosecuting such appeal, protest, abatement, or other contest. ~~The~~ Interconnection Customer, Transmission Owner and the CAISO if applicable, ~~and the Participating TO~~ shall cooperate in good faith with respect to any such contest. Unless the payment of such taxes is a prerequisite to an appeal or abatement or cannot be deferred, no amount shall be payable by ~~the~~ Interconnection Customer to Transmission Owner or the CAISO ~~or Participating TO~~ for such taxes until they are assessed by a final, non-appealable order by any court or agency of competent jurisdiction. In the event that a tax payment is withheld and ultimately due and payable after appeal, ~~the~~ Interconnection Customer will be responsible for all taxes, interest and penalties, other than penalties attributable to any delay caused by ~~the Participating TO~~Transmission Owner or the CAISO.

5.18 Tax Status. Each Party shall cooperate with the others to maintain the other Parties' tax status. Nothing in this LGA Agreement is intended to adversely affect any Transmission

Owner's or the CAISO's ~~or any Participating TO~~'s tax exempt status with respect to the issuance of bonds including, but not limited to, Local Furnishing Bonds.

5.19 Modification.

5.19.1 General. The Interconnection Customer or the ~~Participating TO~~ Transmission Owners may undertake modifications to ~~its~~ their respective facilities, subject to the provisions of this ~~LGIA and the CAISO Tariff. If a Party plans~~ Agreement and any applicable provisions of any applicable Tariff. If either the Interconnection Customer on the one hand, or Transmission Owners on the other hand, plan to undertake a modification that reasonably may be expected to affect the other ~~Parties'~~ s facilities, ~~that~~ the Party planning the modification shall provide to the other Parties sufficient information regarding such modification so that the other Parties may evaluate the potential impact of such modification prior to commencement of the work or implementation of the modification. Such information shall be deemed to be confidential hereunder and shall include information concerning the timing of such modifications and whether such modifications are expected to interrupt the flow of electricity from the Large Generating Facility. The Party desiring to perform such work or implement the modification shall provide the relevant drawings, plans, and specifications to the other Parties at least ninety (90) Calendar Days in advance of the commencement of the work or implementation of the modification or such shorter period upon which the Parties may agree, which agreement shall not unreasonably be withheld, conditioned or delayed.

In the case of Large Generating Facility modifications that do not require ~~the~~ Interconnection Customer to submit an Interconnection Request, Transmission Owners and the CAISO ~~or Participating TO~~ shall provide, within thirty (30) Calendar Days (or such other time as the Parties may agree), an estimate of any additional modifications to the ~~CAISO Controlled Grid, Participating TO's~~ Transmission Systems, Transmission Owners' Interconnection Facilities, or Network Upgrades or Distribution Upgrades necessitated by such Interconnection Customer modification and a good faith estimate of the costs thereof. The ~~Participating TO~~ Transmission Owners and the CAISO shall each determine if a Large Generating Facility modification is a Material Modification in accordance with ~~the LGIP~~ their respective Large Generator Interconnection Procedures.

Notwithstanding anything in this Agreement to the contrary, any modification to the Large Generating Facility or the terms upon which Interconnection Service is provided hereunder that requires additional facilities beyond or in lieu of those facilities specifically identified in Appendices A-1, A-2, and A-3, including but not limited to additional Transmission Owners' Interconnection Facilities or Network Upgrades, shall be dealt with in a separate Large Generator Interconnection Agreement or in an amendment to this Agreement agreed to by all Parties; provided, however, that to the extent IID determines the modification requires additional non-JPP facilities owned by IID, such change may be dealt

with in a separate Affected System Study Agreement and/or Affected System Construction and Operation Agreement.

5.19.2 Standards. Any additions, modifications, or replacements made to ~~a Party's facilities~~the Transmission Systems or Transmission Owners' Interconnection Facilities that may reasonably be expected to affect the Generating Facility or Interconnection Facilities shall be designed, constructed and operated in accordance with this ~~LGIA~~Agreement, Applicable Reliability Standards, and Good Utility Practice. Any additions, modifications, or replacements made to the Generating Facility or Interconnection Customer's Interconnection Facilities that may reasonably be expected to affect the Transmission Systems or Transmission Owners' Interconnection Facilities shall be designed, constructed and operated in accordance with this Agreement, Applicable Reliability Standards, and Good Utility Practice.

~~5.19.3~~ **5.19.3 Modification Costs.** ~~The~~ Interconnection Customer shall not be directly assigned for the costs of any additions, modifications, or replacements that ~~the Participating TO makes to the Participating TO's~~Transmission Owners make to Transmission Owners' Interconnection Facilities or ~~the Participating TO to each respective Transmission Owner's~~Transmission Owners' Interconnection Facilities or the Participating TO applicable Transmission Owner's Transmission System, or to provide transmission service to a third party under the ~~CAISO~~applicable Tariff, *i.e., APS, IID and the CAISO*. ~~The~~ Interconnection Customer shall be responsible for the costs of any additions, modifications, or replacements to ~~the~~ Interconnection Facilities that may be necessary to maintain or upgrade such Interconnection Facilities consistent with Applicable Laws and Regulations, Applicable Reliability Standards or Good Utility Practice.

~~ARTICLE 6. TESTING AND INSPECTION~~

Article 6. Testing and Inspection

6.1 Pre-Commercial Operation Date Testing and Modifications. Prior to the Commercial Operation Date, ~~the Participating TO~~APS, on behalf of Transmission Owners, shall test ~~the Participating TO's~~Transmission Owners' Interconnection Facilities, ~~Network Upgrades, and Distribution Upgrades and the~~and Network Upgrades to the JPP in Appendices A-1 and A-2, and SDG&E shall test Network Upgrades to its non-JPP facilities in Appendix A-3. To the extent that the Affected System Study performed by IID identifies the need to install or construct any Network Upgrades to non-JPP facilities owned by IID, then IID shall test such Network Upgrades to non-JPP facilities prior to the Commercial Operation Date and Interconnection Customer shall test the Large Generating Facility and ~~the~~ Interconnection Customer's Interconnection Facilities to ensure their safe and reliable operation. Similar testing may be required after initial operation. ~~Each Party~~APS, on behalf of Transmission Owners, SDG&E, IID, and the Interconnection Customer shall make any modifications to ~~its~~their respective facilities that are found to be necessary as a result of such testing. The Interconnection Customer shall bear the cost of all such testing and modifications. The Interconnection

Customer shall not commence initial parallel operation of ~~an Electric Generating Unit with the Participating TO's~~ the first Project Block for Phase A of the Generating Facility or the first Project Block of Phase B of the Generating Facility with the Transmission System until the Participating TO provides Transmission Owners provide prior written approval, which ~~approval~~ shall not be unreasonably withheld, for operation of such ~~Electric Generating Unit. The Project Phase.~~ Interconnection Customer shall generate test energy at the Large Generating Facility only if it has arranged for the delivery of such test energy.

- 6.2 Post-Commercial Operation Date Testing and Modifications.** ~~Each~~ As between Transmission Owners for the JPP facilities in Appendices A-1 and A-2, SDG&E for its non-JPP facilities in Appendix A-3, and IID for its non-JPP facilities, if any are identified in the Affected System Study, respectively, and Interconnection Customer, each Party shall at its own expense perform routine inspection and testing of its facilities and equipment in accordance with Good Utility Practice as may be necessary to ensure the continued interconnection of the Large Generating Facility with the ~~Participating TO's Transmission System~~ JPP in a safe and reliable manner. ~~Each~~ As between Transmission Owners for the JPP facilities in Appendices A-1 and A-2, SDG&E for its non-JPP facilities in Appendix A-3, and IID for its non-JPP facilities, if any are identified in the Affected System Study, respectively, and Interconnection Customer, each Party shall have the right, upon advance written notice, to require reasonable additional testing of the other Party's facilities, at the requesting Party's expense, as may be in accordance with Good Utility Practice.
- 6.3 Right to Observe Testing.** Each Party shall notify the other Parties at least fourteen (14) Calendar Days in advance of its performance of tests of its Interconnection Facilities or Generating Facility. The other Parties have the right, at their own expense, to observe such testing.
- 6.4 Right to Inspect.** Each Party shall have the right, but shall have no obligation to: (i) observe another Party's tests and/or inspection of any of its System Protection Facilities and other protective equipment, including Power System Stabilizers; (ii) review the settings of another Party's System Protection Facilities and other protective equipment; and (iii) review another Party's maintenance records relative to the Interconnection Facilities, the System Protection Facilities and other protective equipment. A Party may exercise these rights from time to time as it deems necessary upon reasonable notice to the other Party. The exercise or non-exercise by a Party of any such rights shall not be construed as an endorsement or confirmation of any element or condition of the Interconnection Facilities or the System Protection Facilities or other protective equipment or the operation thereof, or as a warranty as to the fitness, safety, desirability, or reliability of same. Any information that a Party obtains through the exercise of any of its rights under this Article 6.4 shall be deemed to be Confidential Information and treated pursuant to Article 22 of this ~~LGIA~~ Agreement.

ARTICLE 7. METERING

Article 7. Metering

- 7.1 General.** Each Party shall comply with any Applicable Reliability Standards and the Applicable Reliability Council requirements. ~~The Interconnection Customer and~~

~~CAISO shall comply with the provisions of the CAISO Tariff regarding metering, including Section 10 of the CAISO Tariff.~~ Unless otherwise agreed by the ~~Participating TO and the Interconnection Customer, the Participating TO may install additional~~Parties, APS, on behalf of Transmission Owners, shall install Metering Equipment at the Point of Interconnection prior to any operation of ~~any Electric~~the Large Generating ~~Unit~~Facility and shall own, operate, test and maintain such Metering Equipment. Power flows to and from the Large Generating Facility shall be measured at or, at ~~the CAISO's or Participating TO's~~Transmission Owners' option ~~for its respective Metering Equipment,~~ compensated to, the Point of Interconnection. ~~The CAISO~~APS, on behalf of Transmission Owners, shall provide metering quantities, in analog and/or digital form, to ~~the~~ Interconnection Customer upon request ~~in accordance with the CAISO Tariff by directly polling the CAISO's meter data acquisition system.~~ ~~The~~ Interconnection Customer shall bear all reasonable documented costs associated with the purchase, installation, operation, testing and maintenance of the Metering Equipment.

7.2 **Check Meters.** ~~The~~ Interconnection Customer, at its option and expense, may install and operate, on its premises and on its side of the Point of Interconnection, one or more check meters to check ~~the CAISO-pollled meters or the Participating TO's~~Transmission Owners' meters. Such check meters shall be for check purposes only and shall not be used for the measurement of power flows for purposes of this ~~LGIA,~~ ~~except in the case that no other means are available on a temporary basis at the option of the CAISO or the Participating TO~~Agreement, except as provided in Article 7.4 below. The check meters shall be subject at all reasonable times to inspection and examination by ~~the CAISO or Participating TO or their designees~~APS, on behalf of Transmission Owners, or its designee. The installation, operation and maintenance thereof shall be performed entirely by ~~the~~ Interconnection Customer in accordance with Good Utility Practice.

~~7.3 Participating TO Retail Metering. The Participating TO may install retail revenue quality meters and associated equipment, pursuant to the Participating TO's applicable retail tariffs.~~

~~7.3 Standards. APS, on behalf of Transmission Owners, shall install, calibrate, and test revenue quality Metering Equipment in accordance with applicable ANSI standards.~~

7.4 Testing of Metering Equipment. APS, on behalf of Transmission Owners, shall inspect and test all Transmission Owner Metering Equipment for the JPP upon installation and at least once every two (2) years thereafter. If requested to do so by Interconnection Customer, APS, on behalf of Transmission Owners, shall, at Interconnection Customer's expense, inspect or test such Metering Equipment more frequently than every two (2) years. APS, on behalf of Transmission Owners, shall give reasonable notice of the time when any inspection or test shall take place, and Interconnection Customer may have representatives present at the test or inspection. If at any time Metering Equipment is found to be inaccurate or defective, it shall be adjusted, repaired or replaced at Interconnection Customer's expense, in order to provide accurate metering, unless the inaccuracy or defect is due to Transmission Owners' failure to maintain, then Transmission Owners shall pay. If Metering Equipment fails to register, or if the

measurement made by Metering Equipment during a test varies by more than two percent from the measurement made by the standard meter used in the test, APS, on behalf of Transmission Owners, shall adjust the measurements by correcting all measurements for the period during which Metering Equipment was in error by using Interconnection Customer's check meters, if installed. If no such check meters are installed or if the period cannot be reasonably ascertained, the adjustment shall be for the period immediately preceding the test of the Metering Equipment equal to one-half the time from the date of the last previous test of the Metering Equipment.

7.5 Metering Data. At Interconnection Customer's expense, the metered data shall be telemetered to one or more locations designated by Transmission Owners and one or more locations designated by Interconnection Customer. Subject to Article 7.6, such telemetered data shall be used, under normal operating conditions, as the official measurement of the amount of energy delivered from the Large Generating Facility to the Point of Interconnection.

7.6 Metering Requirements of CAISO. Notwithstanding the other provisions of Article 7, if the Interconnection Customer elects the CAISO as the Balancing Authority for a Project Phase, the Interconnection Customer shall also comply with the metering requirements of the CAISO Tariff for such Phase, including installation of Metering Equipment in compliance with the requirements of the CAISO Tariff. For Phase A of the Generating Facility the Interconnection Customer has selected the CAISO as the Balancing Authority, so for Phase A of the Generating Facility, in addition to the requirements of this Article 7, the Interconnection Customer shall also comply with the metering requirements of the CAISO Tariff. If the Interconnection Customer elects the CAISO as the Balancing Authority for Phase B of the Generating Facility pursuant to Article 9.2 of this Agreement, the Interconnection Customer shall also comply with the requirements of this Article 7 and the metering requirements of the CAISO Tariff for Phase B of the Generating Facility. Notwithstanding the provisions of Article 7.5, for any Project Phase in the CAISO Balancing Authority Area, data from the CAISO-compliant metering shall be used, under normal operating conditions, as the official measurement of the amount of energy delivered from the Large Generating Facility to the Point of Interconnection. Any Metering Equipment installed by APS on behalf of the Transmission Owners will serve as an alternative source for meter data for the CAISO in the event of failure of the CAISO-compliant metering to provide accurate meter data.

ARTICLE 8. COMMUNICATIONS

Article 8. Communications

8.1 Interconnection Customer Obligations. ~~The~~ Interconnection Customer shall maintain satisfactory operating communications with ~~the CAISO in accordance with the provisions of the CAISO Tariff and with the Participating TO's~~ APS's Transmission System dispatcher or representative designated by ~~the Participating TO.~~ ~~The~~ APS, and with CAISO, to the extent CAISO is selected by Interconnection Customer as Balancing Authority for a Project Phase. Interconnection Customer shall provide standard voice line, dedicated voice line and facsimile communications at its Large Generating Facility control room or central dispatch facility through use of either the public telephone system, or a voice communications system that does not rely on the public telephone system. ~~The~~ Interconnection Customer shall also provide the dedicated

data circuit(s) necessary to provide Interconnection Customer data to ~~the CAISO and Participating TO~~ APS, on behalf of Transmission Owners as set forth in Appendix D, Security Arrangements Details, and as applicable, to CAISO. The data circuit(s) shall extend from the Large Generating Facility to the location(s) specified by APS, on behalf of Transmission Owners, and ~~the CAISO and Participating TO~~. Any required maintenance of such communications equipment shall be performed by ~~the~~ Interconnection Customer. Operational communications shall be activated and maintained under, but not be limited to, the following events: system paralleling or separation, scheduled and unscheduled shutdowns, equipment clearances, and hourly and daily load data.

- 8.2 Remote Terminal Unit.** Prior to the Initial Synchronization Date of ~~each Electric Generating Unit~~ any Project Phase, a Remote Terminal Unit, or equivalent data collection and transfer equipment acceptable to the Parties, shall be installed by ~~the~~ Interconnection Customer, or by ~~the Participating TO at the~~ APS, on behalf of Transmission Owners, at Interconnection Customer's expense, to gather accumulated and instantaneous data to be telemetered to the location(s) designated by ~~the CAISO and by the Participating TO~~ APS, on behalf of Transmission Owners, through use of a dedicated point-to-point data circuit(s) as indicated in Article 8.1. ~~Telemetry to the CAISO shall be provided in accordance with the CAISO's technical standards for direct telemetry. For telemetry to the Participating TO,~~ the communication protocol for the data circuit(s) shall be specified by ~~the Participating TO~~ APS, on behalf of Transmission Owners. Instantaneous bi-directional analog real power and reactive power flow ~~and any other required~~ information must be telemetered directly to the location(s) specified by ~~the Participating TO~~ APS.

~~Each~~ As among APS, on behalf of Transmission Owners, CAISO and Interconnection Customer, each such Party will promptly advise the other Parties if it detects or otherwise learns of any metering, telemetry or communications equipment errors or malfunctions that require the attention and/or correction by ~~another Party~~ the other Parties. The Party owning such equipment shall correct such error or malfunction as soon as reasonably feasible.

- 8.3 No Annexation.** Any and all equipment placed on the premises of a Party shall be and remain the property of the Party providing such equipment regardless of the mode and manner of annexation or attachment to real property, unless otherwise mutually agreed by the Parties.

- 8.4 Communication Requirements of CAISO.** Notwithstanding the other provisions of Article 8, if the Interconnection Customer elects the CAISO as the Balancing Authority for a Project Phase, the Interconnection Customer shall also comply with the communications requirements of the CAISO Tariff. For Phase A of the Generating Facility the Interconnection Customer has selected the CAISO as the Balancing Authority, so for Phase A of the Generating Facility, in addition to the requirements of this Article 8, the Interconnection Customer shall also comply with the communications requirements of the CAISO Tariff. If the Interconnection Customer elects the CAISO as the Balancing Authority for Phase B of the Generating Facility pursuant to Article 9.2 of this Agreement, the Interconnection Customer shall also comply with the requirements of

[this Article 8 and the communications requirements of the CAISO Tariff for Phase B of the Generating Facility.](#)

ARTICLE 9. OPERATIONS

Article 9. Operations

- 9.1 General.** Each Party shall comply with Applicable Reliability Standards and the Applicable Reliability Council requirements. Each Party shall provide to the other ~~Party~~Parties all information that may reasonably be required by the other ~~Party~~Parties to comply with Applicable Laws and Regulations and Applicable Reliability Standards.
- 9.2 Balancing Authority Area Notification.** At least three months before Initial Synchronization Date ~~of a Project Phase, the~~ Interconnection Customer shall notify APS and the CAISO ~~and Participating TO~~ in writing of the Balancing Authority Area in which ~~the Large Generating Facility intends to be located. If the Interconnection Customer intends to locate the Large Generating Facility in a Balancing Authority Area other than the Balancing Authority Area within whose electrically metered boundaries the Large Generating Facility is located, and that Project Phase will be located,~~ if and as permitted ~~to do so~~ by the relevant transmission tariffs, all including the APS and CAISO Tariffs. All necessary arrangements, including but not limited to those set forth in ~~Article~~Articles 7 and ~~Article~~ 8 of this LGIA Agreement, and remote Balancing Authority Area generator interchange agreements, if applicable, and the appropriate measures under such agreements, shall be executed and implemented prior to the placement ~~of the Large Generating Facility~~a Project Phase in the ~~other~~designated Balancing Authority Area. Separate notifications will be required for each Project Phase, as specified in Appendix C.
- 9.3 CAISO Transmission Owner and Participating TO Obligations.** ~~The CAISO and Participating TO shall cause the Participating TO's Transmission System to be operated and controlled in a safe and reliable manner and in accordance with this LGIA. The Participating TO at the Interconnection Customer's expense shall cause the Participating TO's~~CAISO Obligations. The Transmission Owners and the CAISO shall cause their respective Transmission Systems and APS, on behalf of Transmission Owners, shall cause the Transmission Owners' Interconnection Facilities to be operated, maintained and controlled in a safe and reliable manner and in accordance with this LGIA Agreement. ~~The APS and the CAISO and Participating TO~~ may provide operating instructions to ~~the~~ Interconnection Customer consistent with this LGIA Agreement and ~~Participating TO and APS's or the~~ CAISO's operating protocols and procedures as they may change from time to time. ~~The Participating TO APS and the~~ CAISO will consider changes to their respective operating protocols and procedures proposed by ~~the~~ Interconnection Customer.
- 9.4 Interconnection Customer Obligations.** ~~The~~ Interconnection Customer shall at its own expense operate, maintain and control the Large Generating Facility and ~~the~~ Interconnection Customer's Interconnection Facilities in a safe and reliable manner and in accordance with this LGIA Agreement. ~~The~~ Interconnection Customer shall operate

the Large Generating Facility and ~~the~~ Interconnection Customer's Interconnection Facilities in accordance with all applicable requirements of the Balancing Authority Area of which it is part, ~~including as~~ such requirements ~~as are~~ set forth in Appendix C, Interconnection Details, of this ~~LGIA—Agreement~~. Appendix C, Interconnection Details, will be modified to reflect changes to the requirements as they may change from time to time. A Party may request that ~~another Party~~ the other Parties provide copies of the requirements set forth in Appendix C, Interconnection Details, of this ~~LGIA—The Interconnection Customer shall not commence Commercial Operation of an Electric Generating Unit with the Participating TO's Transmission System until the Participating TO provides prior written approval, which approval shall not be unreasonably withheld, for operation of such Electric Generating Unit.~~ Agreement.

9.5 Start-Up and Synchronization. Consistent with the Parties' mutually acceptable procedures, ~~the~~ Interconnection Customer is responsible for the proper synchronization of ~~each Electric~~ the Large Generating ~~Unit~~ Facility to the ~~CAISO Controlled Grid-~~ JPP.

9.6 Reactive Power.

9.6.1 Power Factor Design Criteria. Interconnection Customer shall design Phase A of the Large Generating Facility to maintain a composite power delivery at continuous rated power output at the Point of Interconnection at a power factor within the range of 0.95 leading to 0.95 lagging, which power factor range shall supersede any otherwise applicable power factor range set forth in the CAISO Tariff. The Interconnection Customer shall design Phase B of the Large Generating Facility to maintain a composite power delivery at continuous rated power output at the ~~terminals of the Electric Generating Unit~~ Point of Interconnection at a power factor within the range of 0.95 leading to ~~0.90 lagging, unless the CAISO has established different requirements that apply to all generators in the Balancing Authority Area on a comparable basis. Power factor design criteria for wind generators are provided in Appendix H of this LGIA~~ 0.95 lagging or the Applicable Reliability Standard in effect at the time the Interconnection Studies for Phase B of the Generating Facility are performed. For Phase B of the Generating Facility, the Interconnection Studies for that Project Phase demonstrate or shall demonstrate that that Project Phase complies with Article 9.6.1 before Phase B of the Interconnection Project commences Trial Operation.

9.6.2 Voltage Schedules. ~~Once the~~ APS shall be responsible for compliance with Applicable Reliability Standards related to reactive power and voltage schedules for the interconnection of the Large Generating Facility to the JPP, subject to any agreement entered into by APS and the CAISO regarding the allocation of responsibilities for compliance with Applicable Reliability Standards. Pursuant to that responsibility, once Interconnection Customer has synchronized ~~an~~ Electric the Large Generating ~~Unit~~ Facility with the ~~CAISO Controlled Grid, the CAISO or Participating TO~~ JPP, APS shall require ~~the~~ Interconnection Customer to ~~maintain a voltage schedule by operating the~~

~~Electric~~ operate the Large Generating Unit Facility to produce or absorb reactive power within the design limitations of the ~~Electric~~ Large Generating Unit Facility set forth in Article 9.6.1 (Power Factor Design Criteria). ~~CAISO's voltage schedules, Appendix C, and the Interconnection Customer's data, as revised, that were provided for the Interconnection Studies.~~ Voltage schedules required by APS shall treat all sources of reactive power ~~in~~ interconnected to the ~~Balancing Authority Area~~ JPP in an equitable and not unduly discriminatory manner. ~~The Participating TO~~ APS shall exercise Reasonable Efforts to provide ~~the~~ Interconnection Customer with such schedules at least one (1) day in advance, and ~~the CAISO or Participating TO~~ may make changes to such schedules as necessary to maintain the reliability of the ~~CAISO Controlled Grid or the Participating TO's electric system.~~ The Transmission Systems. Interconnection Customer shall operate the ~~Electric~~ Large Generating Unit Facility to maintain the specified output voltage or power factor at the Point of Interconnection within the design limitations of the ~~Electric~~ Large Generating Unit Facility set forth in Article 9.6.1 (Power Factor Design Criteria), and ~~as may be required by the CAISO to operate the Electric Generating Unit at a specific voltage schedule within the design limitations set forth in Article 9.6.1.~~ If the the Interconnection Customer's data, as revised, that were provided for the Interconnection Studies. If Interconnection Customer is unable to maintain the specified voltage or power factor, it shall promptly notify the ~~CAISO and the Participating TO~~ APS system operator.

9.6.2.1 Governors and Regulators. ~~Whenever an Electric Generating Unit~~ To the extent required by Applicable Reliability Standards, the Interconnection Customer shall procure, install, and maintain governors and regulators. To the extent required by Applicable Reliability Standards, whenever the Large Generating Facility is operated in parallel with the ~~CAISO Controlled Grid~~ Transmission System and the speed governors (if installed on the ~~Electric Generating Unit~~ generating unit pursuant to Good Utility Practice) and voltage regulators are capable of operation, ~~the~~ Interconnection Customer shall operate the ~~Electric~~ Large Generating Unit Facility with its speed governors and voltage regulators in automatic operation. If the ~~Electric~~ Large Generating Unit Facility's speed governors and voltage regulators are not capable of such automatic operation, ~~the~~ Interconnection Customer shall immediately notify APS and the CAISO ~~and the Participating TO~~ and ensure that ~~the Electric~~ such Large Generating Unit Facility operates as specified in Article 9.6.2 through manual operation and that ~~such Electric Generating Unit's~~ its reactive power production or absorption (measured in MVARs) are within the design capability of the ~~Electric~~ Large Generating Unit Facility's generating unit(s) and steady state stability limits. The Interconnection Customer shall restore the speed governors and voltage regulators to automatic operation as soon as possible. If the Large Generating Facility's speed governors and voltage regulators are improperly tuned or malfunctioning, APS or the CAISO shall have the right to order the reduction in output or disconnection of

the Large Generating Facility if the reliability of the ~~CAISO Controlled-Grid~~Transmission System would be adversely affected. ~~The~~ Interconnection Customer shall not cause its Large Generating Facility to disconnect automatically or instantaneously from the ~~CAISO Controlled-Grid~~Transmission System or trip any ~~Electric~~Generating Unitgenerating unit comprising the Large Generating Facility for an under or over frequency condition unless the abnormal frequency condition persists for a time period beyond the limits set forth in ANSI/IEEE Standard C37.106, or such other standard as applied to other generators ~~in~~interconnecting to the ~~Balancing Authority Area~~JPP on a comparable basis.

9.6.3 Payment for Reactive Power. ~~CAISO~~APS is required to pay ~~the~~ Interconnection Customer for reactive power that Interconnection Customer provides or absorbs from ~~an~~Electric~~the Large~~ UnitFacility when ~~the~~CAISOAPS requests ~~the~~ Interconnection Customer to operate its ~~Electric~~Large Generating UnitFacility outside the range specified in Article 9.6.1, provided that if ~~the~~CAISOAPS pays ~~other~~its own or affiliated generators for reactive power service within the specified range, it must also pay ~~the~~ Interconnection Customer. Payments shall be pursuant to Article 11.6 or such other agreement to which the ~~CAISO and Interconnection Customer~~Parties have otherwise agreed.

9.7 Outages and Interruptions.

9.7.1 Outages.

9.7.1.1 Outage Authority and Coordination. Each Party may in accordance with Good Utility Practice in coordination with the other Parties remove from service any of its respective Interconnection Facilities or Network Upgrades that may impact ~~another Party's~~the other Parties' facilities as necessary to perform maintenance or testing or to install or replace equipment, provided that the Interconnection Customer shall also coordinate outages of the Generating Facility with the CAISO pursuant to the provisions of the CAISO Tariff for each Project Phase that is within the CAISO Balancing Authority Area, and APS shall coordinate outages of the JPP and Transmission Owner Interconnection Facilities with the CAISO in accordance with agreed procedures. Absent an Emergency Condition, the Party scheduling a removal of such facility(ies) from service will use Reasonable Efforts to schedule such removal on a date and time mutually acceptable to ~~all~~the Parties. In all circumstances, any Party planning to remove such facility(ies) from service shall use Reasonable Efforts to minimize the effect on the other ~~Parties~~Party of such removal.

9.7.1.2 Outage Schedules. ~~The~~ APS, IID and CAISO shall post scheduled outages of ~~CAISO Controlled-Grid~~their respective transmission facilities in accordance with ~~the provisions of the CAISO~~applicable

Tariff requirements. ~~The~~ Interconnection Customer shall submit its planned maintenance schedules for the Large Generating Facility to APS for a minimum of a rolling twenty-four month period and to the CAISO in accordance with the CAISO Tariff for any Project Phase in the CAISO Balancing Authority Area. ~~The~~ Interconnection Customer shall update its planned maintenance schedules as necessary, including providing updates to the CAISO in accordance with the CAISO Tariff. ~~The CAISO may request the~~ APS, on behalf of Transmission Owners, and the CAISO, in accordance with the applicable provisions of the CAISO Tariff, may request Interconnection Customer to reschedule its maintenance as necessary to maintain the reliability of ~~the CAISO Controlled Grid in accordance with the CAISO Tariff~~. ~~Such planned maintenance schedules and updates and changes to such schedules shall be provided by the~~ Transmission Owners' and the CAISO Transmission Systems; provided, however, adequacy of generation supply shall not be a criterion in determining Transmission System reliability, subject to Section 9 of the CAISO Tariff. APS shall compensate Interconnection Customer ~~to the Participating TO concurrently with their submittal to the CAISO for any additional direct costs that Interconnection Customer incurs as a result of having to reschedule maintenance, including any additional overtime, breaking of maintenance contracts or other costs above and beyond the cost Interconnection Customer would have incurred absent APS's request to reschedule maintenance~~. The CAISO shall compensate ~~the~~ Interconnection Customer for any additional direct costs that ~~the~~ Interconnection Customer incurs as a result of having to reschedule maintenance in accordance with the CAISO Tariff. ~~The~~ Interconnection Customer will not be eligible to receive compensation, if during the twelve (12) months prior to the date of the scheduled maintenance, ~~the~~ Interconnection Customer had modified its schedule of maintenance activities.

9.7.1.3 Outage Restoration. If an outage on a Party's Interconnection Facilities or Network Upgrades adversely affects another Party's operations or facilities, the Party that owns or controls the facility that is out of service shall use Reasonable Efforts to promptly restore such facility(ies) to a normal operating condition consistent with the nature of the outage. The Party that owns or controls the facility that is out of service shall provide the other Parties, to the extent such information is known, information on the nature of the Emergency Condition, if the outage is caused by an Emergency Condition, an estimated time of restoration, and any corrective actions required. Initial verbal notice shall be followed up as soon as practicable with written notice explaining the nature of the outage, if requested by a Party, which may be provided by e-mail or facsimile.

9.7.2 Interruption of Service. If required by Good Utility Practice to do so, ~~the CAISO or the Participating TO~~ APS, on behalf of the Transmission Owners,

may require ~~the~~ Interconnection Customer to interrupt or reduce deliveries of electricity if such delivery of electricity could adversely affect the ~~CAISO's or the Participating TO's~~ ability of APS to perform such activities as are necessary to safely and reliably operate and maintain the ~~Participating TO's electric system or the CAISO Controlled Grid~~ Transmission System. If the Interconnection Customer elects the CAISO as the Balancing Authority for a Project Phase, the CAISO may also have authority to require Interconnection Customer to curtail or interrupt such generation in accordance with the procedures established for generators in the CAISO Balancing Authority Area, in which case the procedures established by the CAISO pursuant to the CAISO Tariff shall apply in lieu of the provisions of this Article 9.7.2. APS or the CAISO shall notify the other as soon as possible of any curtailment, interruption, or reduction of deliveries from the Large Generating Facility that it may require. The following provisions shall apply to any interruption or reduction by APS permitted under this Article 9.7.2:

- 9.7.2.1 The interruption or reduction shall continue only for so long as reasonably necessary under Good Utility Practice;
- 9.7.2.2 Any such interruption or reduction shall be made on an equitable, non-discriminatory basis with respect to all generating facilities directly connected to ~~the CAISO Controlled Grid, subject to any conditions specified in this LGIA;~~ its Transmission System;
- 9.7.2.3 When the interruption or reduction must be made under circumstances which do not allow for advance notice, ~~the CAISO or Participating TO, as applicable,~~ APS shall notify ~~the~~ Interconnection Customer by telephone as soon as practicable of the reasons for the curtailment, interruption, or reduction, and, if known, its expected duration. Telephone notification shall be followed by written notification, if requested by the Interconnection Customer, as soon as practicable;
- 9.7.2.4 Except during the existence of an Emergency Condition, when ~~the CAISO or Participating TO~~ interruption or reduction can be scheduled without advance notice, APS shall notify ~~the~~ Interconnection Customer in advance regarding the timing of such ~~interruption or reduction~~ scheduling and further notify ~~the~~ Interconnection Customer of the expected duration. ~~The CAISO or Participating TO~~ APS shall coordinate with ~~the~~ Interconnection Customer using Good Utility Practice to schedule the interruption or reduction during periods of least impact to ~~the~~ Interconnection Customer, ~~the CAISO, and the Participating TO~~ and APS, acting on behalf of the Transmission Owners;
- 9.7.2.5 The Parties shall cooperate and coordinate with each other to the extent necessary in order to restore the Large Generating Facility, Interconnection Facilities, ~~the Participating TO's and their~~ Transmission System, and the CAISO Controlled Grid Systems to

their normal operating state, consistent with system conditions and Good Utility Practice.

9.7.3 Under-Frequency and Over Frequency Conditions. The ~~CAISO Controlled Grid~~Transmission System is designed to automatically activate a load-shed program as required by Applicable Reliability Standards and the Applicable Reliability Council in the event of an under-frequency system disturbance. ~~The~~ Interconnection Customer shall implement under-frequency and over-frequency protection set points for the Large Generating Facility as required by the Applicable Reliability Standards and ~~the~~ Applicable Reliability Council to ensure “ride through” capability of the Transmission System. Large Generating Facility response to frequency deviations of pre-determined magnitudes, both under-frequency and over-frequency deviations, shall be studied and coordinated with ~~the Participating TO~~APS and the CAISO in accordance with Good Utility Practice. The term “ride through” as used herein shall mean the ability of a Generating Facility to stay connected to and synchronized with the ~~CAISO Controlled Grid~~Transmission System during system disturbances within a range of under-frequency and over-frequency conditions, in accordance with Good Utility Practice.

9.7.4 System Protection and Other Control Requirements.

9.7.4.1 System Protection Facilities. ~~The~~ Interconnection Customer shall, at its expense, install, operate and maintain System Protection Facilities as a part of the Large Generating Facility or ~~the~~ Interconnection Customer’s Interconnection Facilities. ~~The Participating TO~~Transmission Owners shall install at ~~the~~ Interconnection Customer’s expense any System Protection Facilities that may be required on ~~the Participating TO’s~~Transmission Owners’ Interconnection Facilities ~~or the Participating TO’s and their~~ Transmission System~~Systems~~ as a result of the interconnection of the Large Generating Facility and ~~the~~ Interconnection Customer’s Interconnection Facilities.

9.7.4.2 The ~~Participating TO’s~~Transmission Owners’ and Interconnection Customer’s protection facilities shall be designed and coordinated with other systems in accordance with Applicable Reliability Standards, Applicable Reliability Council criteria, and Good Utility Practice.

9.7.4.3 The ~~Participating TO~~Transmission Owners and Interconnection Customer shall ~~each~~ be responsible for protection of ~~its~~their respective facilities consistent with Good Utility Practice.

9.7.4.4 The ~~Participating TO’s~~Transmission Owners’ and Interconnection Customer’s protective relay design shall incorporate the necessary test switches to perform the tests required in Article 6. The required test switches will be placed such that they allow operation of lockout relays while preventing breaker failure schemes from operating and causing

unnecessary breaker operations and/or the tripping of ~~the~~
Interconnection Customer's ~~Electric Generating Units~~'s units.

9.7.4.5 The ~~Participating TO~~Transmission Owners and Interconnection Customer will ~~test, operate and maintain~~cause to be tested, operated and maintained System Protection Facilities in accordance with Good Utility Practice ~~and, if applicable, the requirements of the Participating TO's Interconnection Handbook.~~

9.7.4.6 Prior to the in-service date, and again prior to the Commercial Operation Date, the ~~Participating TO~~Transmission Owners and Interconnection Customer or their respective agents shall perform a complete calibration test and functional trip test of the System Protection Facilities. At intervals suggested by Good Utility Practice, ~~the standards and procedures of the Participating TO, including, if applicable, the requirements of the Participating TO's Interconnection Handbook,~~ and following any apparent malfunction of the System Protection Facilities, ~~each Party~~the Transmission Owners and Interconnection Customer shall perform both calibration and functional trip tests of ~~its~~their respective System Protection Facilities. These tests do not require the tripping of any in-service generation unit. These tests do, however, require that all protective relays and lockout contacts be activated.

9.7.5 **Requirements for Protection.** In compliance with Good Utility Practice ~~and, if applicable, the requirements of the Participating TO's Interconnection Handbook, the~~ Interconnection Customer shall provide, install, own, and maintain relays, circuit breakers and all other devices necessary to remove any fault contribution of the Large Generating Facility to any short circuit occurring on the ~~Participating TO's~~ Transmission System not otherwise isolated by ~~the Participating TO's~~Transmission Owners' respective equipment, such that the removal of the fault contribution shall be coordinated with the protective requirements of the ~~Participating TO's~~ Transmission System. Such protective equipment shall include, without limitation, a disconnecting device or switch with fault current-interrupting capability located between the Large Generating Facility and the ~~Participating TO's~~ Transmission SystemJPP at a site selected upon mutual agreement (not to be unreasonably withheld, conditioned or delayed) of the Parties. ~~The~~ Interconnection Customer shall be responsible for protection of the Large Generating Facility and ~~the~~ Interconnection Customer's other equipment from such conditions as negative sequence currents, over- or under-frequency, sudden load rejection, over- or under-voltage, and generator loss-of-field. ~~The~~ Interconnection Customer shall be solely responsible to disconnect the Large Generating Facility and ~~the~~ Interconnection Customer's other equipment if conditions on the ~~CAISO Controlled Grid~~Transmission System could adversely affect the Large Generating Facility.

- 9.7.6 Power Quality.** Neither ~~the Participating TO's nor the Interconnection Customer~~ Party's facilities shall cause excessive voltage flicker nor introduce excessive distortion to the sinusoidal voltage or current waves as defined by ANSI Standard C84.1-1989, in accordance with IEEE Standard 519, or any applicable superseding electric industry standard, or ~~any alternative Applicable Reliability Standard or Applicable Reliability Council standard~~. In the event of a conflict among ANSI Standard C84.1-1989, any applicable superseding electric industry standard, or ~~any alternative Applicable Reliability Standard or Applicable Reliability Council standard~~, the ~~alternative~~ Applicable Reliability Standard ~~or Applicable Reliability Council standard~~ shall control.
- 9.8 Switching and Tagging Rules.** Each Party APS, on behalf of Transmission Owners, and the Interconnection Customer shall provide ~~the each~~ other Parties a copy of its switching and tagging rules that are applicable to the other Parties's activities. Such switching and tagging rules shall be developed on a non-discriminatory basis. ~~The Parties~~ APS, on behalf of Transmission Owners, and Interconnection Customer shall comply with applicable switching and tagging rules, as amended from time to time, in obtaining clearances for work or for switching operations on equipment.
- 9.9 Use of Interconnection Facilities by Third Parties.**
- 9.9.1 Purpose of Interconnection Facilities.** Except as may be required by Applicable Laws and Regulations, or as otherwise agreed to among the Parties, the Interconnection Facilities shall be constructed for the sole purpose of interconnecting the Large Generating Facility to the ~~Participating TO's Transmission System~~ JPP and shall be used for no other purpose.
- 9.9.2 Third Party Users.** If required by Applicable Laws and Regulations or if the Parties mutually agree, such agreement not to be unreasonably withheld, to allow one or more third parties to use ~~the Participating TO's~~ Transmission Owners' Interconnection Facilities, or any part thereof, ~~the~~ Interconnection Customer will be entitled to compensation for the capital expenses it incurred in connection with the Interconnection Facilities based upon the pro rata use of the Interconnection Facilities by ~~the Participating TO, all~~ each Transmission Owner, third party ~~users~~ user, and ~~the~~ Interconnection Customer, in accordance with Applicable Laws and Regulations or upon some other mutually-agreed upon methodology. In addition, cost responsibility for ongoing costs, including operation and maintenance costs associated with the Interconnection Facilities, will be allocated between ~~the~~ Interconnection Customer and any third party users based upon the pro rata use of the Interconnection Facilities by ~~the Participating TO, all~~ each Transmission Owner, third party ~~users~~ user, and ~~the~~ Interconnection Customer, in accordance with Applicable Laws and Regulations or upon some other mutually agreed upon methodology. If the issue of such compensation or allocation cannot be resolved through such negotiations, it shall be submitted to ~~FERC for resolution~~ arbitration pursuant to Article 27 of this Agreement or, if a complaint is made against a FERC jurisdictional public

utility that is a Party to this Agreement, to FERC for resolution with respect to that FERC jurisdictional public utility.

- 9.10 Disturbance Analysis Data Exchange.** The Parties will cooperate with one another in the analysis of disturbances to either the Large Generating Facility or the ~~CAISO Controlled Grid~~ Transmission Systems by gathering and providing access to any information relating to any disturbance, including information from oscillography, protective relay targets, breaker operations and sequence of events records, and any disturbance information required by Good Utility Practice.

ARTICLE 10. MAINTENANCE

Article 10. Maintenance

- 10.1 Participating TO Transmission Owner Obligations.** ~~The Participating TO~~ Transmission Owners shall maintain the ~~Participating TO's~~ Transmission System and the Participating TO's Owners' Transmission Systems and Transmission Owners' Interconnection Facilities in a safe and reliable manner and in accordance with this ~~LGIA~~ Agreement.
- 10.2 Interconnection Customer Obligations.** ~~The~~ Interconnection Customer shall maintain the Large Generating Facility and ~~the~~ Interconnection Customer's Interconnection Facilities in a safe and reliable manner and in accordance with this ~~LGIA~~ Agreement.
- 10.3 Coordination.** ~~The Parties~~ APS, on behalf of Transmission Owners, Interconnection Customer and the CAISO shall confer regularly to coordinate the planning, scheduling and performance of preventive and corrective maintenance on the Large Generating Facility and the Interconnection Facilities—, which maintenance coordination shall be consistent with Article 9.7.1.
- 10.4 Secondary Systems.** ~~The Participating TO and~~ APS, on behalf of Transmission Owners, Interconnection Customer and the CAISO shall cooperate with ~~the each~~ other ~~Parties~~ in the inspection, maintenance, and testing of control or power circuits that operate below 600 volts, AC or DC, including, but not limited to, any hardware, control or protective devices, cables, conductors, electric raceways, secondary equipment panels, transducers, batteries, chargers, and voltage and current transformers that directly affect the operation of ~~a Party's~~ such Parties' facilities and equipment which may reasonably be expected to impact the other Parties. ~~Each Party~~ APS, on behalf of Transmission Owners, Interconnection Customer and the CAISO shall provide advance notice to ~~the each~~ other ~~Parties~~ before undertaking any work on such circuits, especially on electrical circuits involving circuit breaker trip and close contacts, current transformers, or potential transformers.
- 10.5 Operating and Maintenance Expenses.** Subject to the provisions herein addressing the use of facilities by others, and except for operations and maintenance expenses associated with modifications made for providing interconnection or transmission service to a third party and such third party pays for such expenses, ~~the~~ Interconnection Customer shall be responsible for all reasonable expenses including overheads, associated with: (1) owning, operating, maintaining, repairing, and replacing ~~the~~ Interconnection Customer's

Interconnection Facilities; and (2) operation, maintenance, repair and replacement of ~~the Participating TO's~~ Transmission Owners' Interconnection Facilities.

ARTICLE 11. PERFORMANCE OBLIGATION

Article 11. Performance Obligation

- 11.1 Interconnection Customer's Interconnection Facilities.** ~~The~~ Interconnection Customer shall design, procure, construct, install, own and/or control ~~the~~ Interconnection Customer's Interconnection Facilities described in ~~Appendix A~~ Appendices A-1 and A-2 at its sole expense.
- 11.2 Participating TO's Transmission Owners' Interconnection Facilities.** ~~The Participating TO~~ APS, on behalf of Transmission Owners, shall design, procure, construct, install, own and/or control the ~~Participating TO's~~ Transmission Owners' Interconnection Facilities described in ~~Appendix A~~ Appendices A-1 and A-2 at the sole expense of the Interconnection Customer. ~~Unless the Participating TO elects to fund the capital for the Participating TO's Interconnection Facilities, they shall be solely funded by the Interconnection Customer.~~
- 11.3 Network Upgrades and Distribution Upgrades.** ~~The Participating TO~~ APS, on behalf of Transmission Owners shall design, procure, construct, and install, and ~~the Transmission Owners shall jointly~~ own the JPP Network Upgrades and Distribution Upgrades described in Appendices A-1 and A-2. SDG&E shall design, procure, construct, install, and own the non-JPP Network Upgrades described in Appendix A. ~~The Interconnection Customer shall be responsible for all costs related to Distribution Upgrades. Unless the Participating TO elects-~~ 3. Unless Transmission Owners, individually or collectively, elect to fund the capital for the ~~Distribution Upgrades and~~ Network Upgrades, they shall be ~~funded by the Interconnection Customer in an amount~~ solely funded by Interconnection Customer. For Network Upgrades to SDG&E's Transmission System, including SDG&E's share of the JPP, the amount of Interconnection Customer's cost responsibility to SDG&E shall be determined pursuant to the methodology set forth in Section ~~13~~ 12.3.1 and Appendix 2 of the LGIP. ~~This specific amount is set forth in Appendix G to this LGIA.~~ CAISO's Large Generator Interconnection Procedures.
- 11.4 Transmission Credits.** ~~No later than thirty (30) Calendar Days prior to the Commercial Operation Date, the Interconnection Customer may make a one-time election by written notice to the CAISO and the Participating TO to receive Congestion Revenue Rights as defined in and as available under the CAISO Tariff at the time of the election in accordance with the CAISO Tariff, in lieu of a refund of the cost of Network Upgrades in accordance with Article 11.4.1.~~
- 11.4.1 Repayment of Amounts Advanced to APS for Network Upgrades.** ~~to APS's Share of the JPP.~~ Interconnection Customer shall be entitled to a cash repayment from APS, equal to the total amount paid by Interconnection Customer to Transmission Owners for the Network Upgrades to the JPP identified in Appendices A-1 and A-2, and not refunded to Interconnection

Customer pursuant to Article 5.17.8 or otherwise, times APS's percentage Ownership Interest in the JPP ("APS's pro rata amount"), plus any tax gross-up or other tax-related payments associated with APS's pro rata amount, to be paid to Interconnection Customer on a dollar-for-dollar basis for the non-usage sensitive portion of transmission charges, as payments are made under APS's Tariff applicable to transmission services on APS's Transmission System with respect to the Large Generating Facility. Such repayment shall include interest calculated in accordance with the methodology set forth in FERC's regulations at 18 C.F.R. § 35.19a(a)(2)(iii) from the date of any payment for JPP Network Upgrades through the date on which the Interconnection Customer receives a repayment of such payment pursuant to this subparagraph. Interconnection Customer may assign such repayment rights to any person.

Notwithstanding the foregoing, Interconnection Customer and APS may adopt an alternative payment schedule that is mutually agreeable so long as APS takes one of the following actions no later than five years from the Commercial Operation Date for a Project Phase: (1) returns to Interconnection Customer any of its pro rata amounts advanced for JPP Network Upgrades not previously repaid, or (2) declares in writing that APS will continue to provide payments to Interconnection Customer on a dollar-for-dollar basis for the non-usage sensitive portion of transmission charges, or develop an alternative schedule that is mutually agreeable and provides for the return of all its pro rata amounts advanced for Network Upgrades not previously repaid; however, full reimbursement by APS of its pro rata amount shall not extend beyond twenty (20) years from the Commercial Operation Date for a Project Phase, and further, if this Agreement terminates within five (5) years from the Commercial Operation Date for that Project Phase, APS's obligation to pay refunds to the Interconnection Customer shall cease as of the date of termination.

If the Large Generating Facility fails to achieve Commercial Operation for a Project Phase, but it or another Generating Facility is later constructed and makes use of the Network Upgrades to the JPP associated with that Project Phase, APS shall at that time reimburse Interconnection Customer for APS's pro rata amount advanced to it for the JPP Network Upgrades for the Project Phase. Before any such reimbursement can occur, the Interconnection Customer, or the entity that ultimately constructs the Generating Facility, if different, is responsible for identifying and demonstrating to APS the entity to which reimbursement must be made in order to implement the intent of this reimbursement obligation.

11.4.2 Repayment of Amounts Advanced to SDG&E for Network Upgrades to Its Share of the JPP and to Its Non-JPP Facilities.

Upon the Commercial Operation Date for a Project Phase, the Interconnection Customer shall be entitled to a repayment, equal to the total amount paid ~~to the Participating TO~~ by Interconnection Customer to SDG&E for the Network Upgrades to the JPP identified in Appendices A-1 and A-2, and not refunded to Interconnection Customer pursuant to Article 5.17.8 or otherwise, times SDG&E's percentage Ownership Interest in the JPP ("SDG&E's pro rata amount"), plus any amount paid to SDG&E for the costs of Network Upgrades

~~for which it is responsible, as to non-JPP facilities owned by SDG&E set forth in Appendix G. Such amount shall include A-3 and not refunded to Interconnection Customer pursuant to Article 5.17.8 or otherwise (“SDG&E’s individual amount”), plus~~ any tax gross-up or other tax-related payments associated with Network Upgrades ~~and~~ not refunded to the Interconnection Customer pursuant to Article 5.17.8 or otherwise, and shall be paid to the Interconnection Customer by ~~the Participating TO~~ SDG&E on a dollar-for-dollar basis either through (1) direct payments made on a levelized basis over the five-year period commencing on the Commercial Operation Date ~~for a Project Phase~~; or (2) any alternative payment schedule that is mutually agreeable to the Interconnection Customer and ~~Participating TO~~ SDG&E, provided that such amount is paid within five (5) years from the Commercial Operation Date ~~for a Project Phase. See also Appendices A-1 and A-2.~~ Notwithstanding the foregoing, if this ~~LGIA Agreement~~ terminates within five (5) years from the Commercial Operation Date, ~~the Participating TO for that Project Phase.~~ SDG&E’s obligation to pay refunds to the Interconnection Customer shall cease as of the date of termination. Any repayment shall include interest calculated in accordance with the methodology set forth in FERC’s regulations at 18 C.F.R. §35.19a(a)(2)(iii) from the date of any payment for Network Upgrades through the date on which the Interconnection Customer receives a repayment of such payment. Interest shall continue to accrue on the repayment obligation so long as this ~~LGIA Agreement~~ is in effect. The Interconnection Customer may assign such repayment rights to any person.

If the Large Generating Facility fails to achieve Commercial Operation ~~for a Project Phase~~, but it or another Generating Facility is later constructed and makes use of the Network Upgrades, ~~the Participating TO associated with that Project Phase,~~ SDG&E shall at that time reimburse Interconnection Customer for ~~the amounts~~ SDG&E’s pro rata amount and the individual amount advanced to SDG&E for the Network Upgrades ~~for the Project Phase~~. Before any such reimbursement can occur, the Interconnection Customer, or the entity that ultimately constructs the Generating Facility, if different, is responsible for identifying and demonstrating to ~~the Participating TO~~ SDG&E the appropriate entity to which reimbursement must be made in order to implement the intent of this reimbursement obligation.

11.4.3 Repayment of Amounts Advanced to IID for Network Upgrades to IID’s Share of the JPP. The Parties acknowledge that IID is not a jurisdictional public utility subject to FERC’s rate jurisdiction under Section 205 or 206 of the Federal Power Act. The responsibility to provide transmission rate credits, under FERC’s generation interconnection regulations, therefore does not extend to IID. See Order No. 2003-C, 111 FERC ¶ 61,401, at P 18 (2005)(citing Order No. 2003, 104 FERC ¶ 61,103, at P 843 (2003)). Notwithstanding its non-jurisdictional status, IID hereby agrees to provide transmission rate credits to Interconnection Customer (or any other qualified person to whom Interconnection Customer assigns its rights to such transmission rate credits) when Point-to-Point Transmission Service is taken on IID’s share of the JPP as follows: IID shall provide such rate credits in an amount equal to the total amount paid by Interconnection Customer to Transmission Owners for the

Network Upgrades to the JPP identified in Appendices A-1 and A-2 and not refunded to Interconnection Customer pursuant to Article 5.17.8 or otherwise, times IID's percentage Ownership Interest in the JPP ("IID's pro rata amount"). Such rate credits shall be provided by IID on a dollar-for-dollar basis for the non-usage sensitive portion of IID's transmission charges (i.e., the demand charge for reserved capacity), as payments are made by Interconnection Customer (or any other qualified person to whom Interconnection Customer assigns its rights to transmission rate credits) to IID under IID's Open Access Transmission Tariff, for a period no longer than twenty (20) years from the Commercial Operation Date for a Project Phase. Notwithstanding the foregoing, if this Agreement terminates within five (5) years from the Commercial Operation Date for that Project Phase, IID's obligation to pay refunds to the Interconnection Customer shall cease as of the date of termination. IID also hereby agrees that Interconnection Customer may assign its rights to such transmission rate credits to any person which qualifies as an Eligible Customer for Point-to-Point Transmission Service under IID's Open Access Transmission Tariff.

If the Large Generating Facility fails to achieve Commercial Operation for a Project Phase, but it or another Generating Facility is later constructed and makes use of the Network Upgrades to the JPP associated with that Project Phase, IID shall reimburse Interconnection Customer for IID's pro rata amount advanced to it for the JPP Network Upgrades for the Project Phase, provided that IID receives payment of those amounts from the entity making use of the JPP Network Upgrades. Before any such reimbursement can occur, the Interconnection Customer, or the entity that ultimately constructs the Generating Facility, if different, is responsible for identifying and demonstrating to IID the appropriate entity to which reimbursement must be made in order to implement the intent of this reimbursement obligation.

11.4.2

11.4.4 Special Provisions for Affected Systems. ~~The~~ Interconnection Customer and any Affected System Operator shall enter into ~~an agreement with the owner of the Affected System and/or other affected owners of portions of the CAISO Controlled Grid, as applicable, in accordance with the LGIP. Such~~ a separate agreement that provides for the repayment of amounts advanced to such Affected System Operator for Network Upgrades. ~~The~~ agreement shall specify the terms governing payments to be made by ~~the Interconnection Customer to the owner of the Affected System and/or other affected owners of portions of the CAISO Controlled Grid~~ Interconnection Customer to the Affected System Operator as well as the repayment by the ~~owner of the Affected System and/or other affected owners of portions of the CAISO Controlled Grid.~~ In no event shall the Participating TO be responsible for the repayment for any facilities that are not part of the Participating TO's Transmission System. In the event the Participating TO is a joint owner with an Affected System or with any other co-owner of a facility affected by the Large Generating Facility, the Participating TO's obligation to reimburse the Interconnection Customer for payments made to

~~address the impacts of the Large Generating Facility on the system shall not exceed the proportionate amount of the cost of any upgrades attributable to the proportion of the jointly-owned facility owned by the Participating TO. Affected System Operator.~~

The Parties acknowledge that an Affected System Study must be performed by IID to analyze system impacts and identify the Network Upgrades, if any, that are required to IID's Transmission System, including its non-JPP facilities, to accommodate Interconnection Requests received by the CAISO from interconnection customers in the CAISO's Transition Cluster, as defined in the CAISO's LGIP, including the Interconnection Customer that is a Party to this Agreement. IID and Interconnection Customer have executed or will execute an Affected System Study Agreement for Phase A of the Generating Facility, whereby IID will perform and Interconnection Customer will pay the costs of an Affected System Study. The total costs will be pro rated to the extent IID performs the Affected System Study in a cluster for multiple generators seeking to interconnect to the CAISO controlled grid, with Interconnection Customer allocated a proportionate share of the total costs. Subject to the terms of a mutually-acceptable Non-Disclosure Agreement between the CAISO and IID, the CAISO shall provide to IID its applicable base case Interconnection Study data to assist IID in performing the Affected System Study.

The Parties acknowledge that there may be a need for an Affected System Study for Phase B of the Generating Facility, as provided for in Appendix C to this Agreement.

If an Affected System Study shows that Network Upgrades are required to IID's Transmission System, other than IID's share of the JPP, Interconnection Customer and IID agree that they shall enter into an Affected System Construction and Operation Agreement and that failure of the Interconnection Customer or IID to enter into such an agreement in accordance with the terms of this Article shall be considered a breach of this Agreement. The Interconnection Customer and IID agree that pursuant to the Affected System Construction and Operation Agreement: (1) Interconnection Customer shall fund the costs of constructing Network Upgrades reasonably attributable to Interconnection Customer; (2) IID shall use Reasonable Efforts to construct any Network Upgrades to IID's non-JPP facilities needed to accommodate Interconnection Customer's Interconnection Request to the CAISO on a schedule consistent with the provisions regarding testing in Article 6.1 of this Agreement; and (3) to the extent that the Interconnection Customer provides funding for any IID Network Upgrades identified in the Affected System Study, IID shall provide rate credits for the amount of such funding, which has not otherwise been refunded, applied on a dollar-for-dollar basis to the non-usage sensitive portion of IID's transmission charges (i.e., the demand charge for reserved capacity), as payments are made by Interconnection Customer (or any other qualified person to whom Interconnection Customer assigns its rights to transmission rate credits) under IID's Tariff, for a period no longer than twenty (20) years from the Commercial Operation Date for the Project Phase.

Any disputes between Interconnection Customer and IID regarding the Affected System Study Agreement or Affected System Construction and Operation Agreement shall be resolved pursuant to the dispute resolution procedures in Section 13.5 of the Generation Interconnection Procedures in IID's Tariff.

11.4.3

11.4.5 Notwithstanding any other provision of this ~~LGIA~~ Agreement, nothing herein shall be construed as relinquishing or foreclosing any rights, including but not limited to firm transmission rights, capacity rights, transmission congestion rights, "Congestion Revenue Rights" defined in and available pursuant to the terms of the CAISO Tariff, or transmission credits, that ~~the~~ Interconnection Customer, shall be entitled to, now or in the future, under any other agreement or tariff as a result of, or otherwise associated with, the transmission capacity, if any, created by the Network Upgrades, including the right to obtain cash reimbursements, merchant transmission "Congestion Revenue Rights" in accordance with Section 36.11 of the CAISO Tariff, or transmission credits for transmission service that is not associated with the Large Generating Facility.

- 11.5** ~~Provision of Interconnection Financial Security. The~~ Security. With regard to SDG&E's share of costs to be incurred for Transmission Owners' Interconnection Facilities and Network Upgrades to the JPP identified in Appendices A-1 and A-2, and for SDG&E's costs of Network Upgrades identified in Appendix A-3, the Interconnection Customer ~~is obligated to~~ shall provide ~~(or cause to be provided)~~ all necessary Interconnection Financial Security required under Section 9 of the CAISO's LGIP in a manner acceptable under Section 9 of the CAISO's LGIP. Failure to satisfy the CAISO's LGIP's requirements for the provision of Interconnection Financial Security shall result in the Interconnection Request being deemed withdrawn and subject to CAISO LGIP Section 3.8.

With regard to APS and IID's shares of the costs to be incurred for Interconnection Facilities and Network Upgrades to the JPP identified in Appendices A-1 and A-2, at least thirty (30) Calendar Days prior to the commencement of the procurement, installation, or construction of Transmission Owners' Interconnection Facilities and JPP Network Upgrades, the Interconnection Customer shall provide (or cause to be provided) APS, on behalf of APS and IID, a guarantee, a surety bond, letter of credit or other form of security that is reasonably acceptable to APS and IID, and is consistent with the Uniform Commercial Code of the jurisdiction identified in Article 14.2.1. Such security for payment shall be in an amount sufficient to cover the costs for constructing, procuring and installing both APS and IID's shares of the Transmission Owners' Interconnection Facilities and JPP Network Upgrades set forth in Appendices A-1 and A-2, and shall be reduced on a dollar-for-dollar basis for payments made to APS, on behalf of APS and IID, for these purposes.

The Parties agree that APS, as the Operating Agent of the JPP under the Participation Agreement, and solely as agent for APS and IID, will accept delivery of the financial security required for the APS and IID shares of the Transmission Owners' Interconnection Facilities and Network Upgrades to the JPP set forth in Appendices A-1 and A-2, which the Interconnection Customer is required to provide (or cause to be provided) in accordance with the milestone schedule set forth in Appendices B-1 and B-2. APS's receipt of any such financial security will be solely as agent for APS and IID.

and APS shall have no obligations to the Interconnection Customer with regard to such financial security other than any obligation it may have for the APS and IID shares of such financial security; APS shall have all obligations, if any, to the Interconnection Customer for the APS and IID shares of such financial security. If it becomes necessary for the Transmission Owners to enforce their financial security rights, APS shall do so, as Operating Agent of the JPP, on behalf of APS and IID in accordance with the procedures set forth in Appendices A-1 and A-2.

SDG&E shall hold the Interconnection Financial Security required for SDG&E's Ownership Share in accordance with the requirements of the CAISO Tariff, provided, however, that if it becomes necessary for the Transmission Owners to enforce their financial security rights, SDG&E shall do so in accordance with the CAISO Tariff and the procedures set forth in Appendices A-1 and A-2.

In addition to complying with all requirements of the CAISO's Large Generator Interconnection Procedures regarding Interconnection Financial Security for security provided to SDG&E:

11.5.1 Any guarantee provided to APS, on behalf of APS and IID, and/or SDG&E, as applicable, must be made by an entity that meets the creditworthiness requirements of APS and IID and/or SDG&E, as applicable, and contain terms and conditions that guarantee payment of any amount that may be due from Interconnection Customer, up to an agreed-to maximum amount.

11.5.2 Any letter of credit to APS, on behalf of APS and IID, and/or SDG&E, as applicable, must be issued by a financial institution reasonably acceptable to APS and IID and/or SDG&E, as applicable, and must specify a reasonable expiration date.

11.5.3 Any surety bond to APS, on behalf of APS and IID, and/or SDG&E, as applicable, must be issued by an insurer reasonably acceptable to APS and IID and/or SDG&E, as applicable, and must specify a reasonable expiration date.

Security shall be provided separately for Phase A of the Interconnection Project and Phase B of the Interconnection Project. Failure of the Interconnection Customer to have any required financial security in place at any time shall constitute grounds for termination of this Agreement pursuant to Articles 2.3 and 17.1, provided, however, Interconnection Customer shall have only 5 (five) Business Days to cure such failure following notice of the default. In addition to the foregoing, the obligation of Transmission Owners to perform under this Agreement is suspended until such failure is cured.

- 11.6 Interconnection Customer Compensation.** If a Transmission Owner or the CAISO requests or directs ~~the~~ Interconnection Customer to provide a service pursuant to ~~Articles 9.6.3 (Payment for Reactive Power) or~~ 13.5.1 of this ~~LGIA~~ Agreement, the Transmission Owner or the CAISO requesting service shall compensate ~~the~~ Interconnection Customer in accordance with ~~the CAISO's~~ Tariff.

11.6.1 Interconnection Customer Compensation for Actions During Emergency Condition. The ~~CAISO shall compensate~~ Transmission Owner or the CAISO requesting the Interconnection Customer ~~in accordance with the CAISO Tariff~~ to provide service during an Emergency Condition shall compensate Interconnection Customer for its provision of real and reactive power and other Emergency Condition services that ~~the~~ Interconnection Customer provides to support ~~the CAISO Controlled Grid~~ its Transmission System during an Emergency Condition in accordance with Article 11.6.

ARTICLE 12. INVOICE

Article 12. Invoice

12.1 General Provisions. ~~For purposes of this Article, as between APS, on behalf of Transmission Owners of the JPP, and Interconnection Customer, each such Party shall submit to the other Party, on a monthly basis, invoices of amounts due for the preceding month with respect to JPP facilities. As between SDG&E, as owner of certain non-JPP facilities under this Agreement, and Interconnection Customer, each such Party shall submit to the other Party, on a monthly basis, invoices of amounts due for the preceding month for such non-JPP facilities owned solely by SDG&E.~~

~~**12.1 General.** The Participating TO shall submit to the Interconnection Customer, on a monthly basis, invoices of amounts due pursuant to this LGIA for the preceding month.~~ Each invoice shall state the month to which the invoice applies and fully describe the services and equipment provided. The Parties may discharge mutual debts and payment obligations due and owing to each other on the same date through netting, in which case all amounts a Party owes to the other Party under this ~~LGIA Agreement~~, including interest payments or credits, shall be netted so that only the net amount remaining due shall be paid by the owing Party; ~~provided, however, that the Parties shall not net amounts relating to JPP facilities with those related to non-JPP facilities.~~ Notwithstanding the foregoing, any invoices between the CAISO and another Party pursuant to the CAISO Tariff shall be submitted and paid in accordance with the CAISO Tariff.

Invoices shall be provided separately for Phase A of the Interconnection Project and Phase B of the Interconnection Project.

12.2 Final Invoice. ~~As soon as reasonably practicable, but within twelve~~ Within six months after completion of the construction of ~~the Participating TO's~~ Transmission Owners' Interconnection Facilities, Network Upgrades, and Distribution Upgrades, the Participating TO shall and the Network Upgrades to the JPP for Phase A of the Interconnection Project and Phase B of the Interconnection Project, APS, on behalf of Transmission Owners, with respect to the Transmission Owners' Interconnection Facilities and JPP Network Upgrades identified in Appendices A-1 and A-2 and SDG&E with respect to its non-JPP Network Upgrades identified in Appendix A-3, shall each provide an invoice of the final cost of the construction of ~~the Participating TO's~~ their respective Transmission Owners' Interconnection Facilities, and the Network Upgrades, ~~and Distribution Upgrades,~~ and shall set forth such costs

in sufficient detail to enable ~~the~~ Interconnection Customer to compare the actual costs with the estimates and to ascertain deviations, if any, from the cost estimates.

With respect to costs associated with the ~~Participating TO's~~ Transmission Owners' Interconnection Facilities and ~~Distribution~~ the JPP Network Upgrades, ~~the Participating TO~~ APS, on behalf of Transmission Owners, shall refund to ~~the~~ Interconnection Customer any amount by which the actual payment by ~~the~~ Interconnection Customer for the estimated costs of such facilities exceeds the actual costs of construction within thirty (30) Calendar Days of the issuance of such final construction invoice; or, in the event the actual costs of construction exceed the Interconnection Customer's actual payment for estimated costs, then the Interconnection Customer shall pay to ~~the Participating TO~~ APS, on behalf of the Transmission Owners, any amount by which the actual costs of construction exceed the actual payment by the Interconnection Customer for the estimated costs within thirty (30) Calendar Days of the issuance of such final construction invoice.

With respect to costs associated with SDG&E's non-JPP Network Upgrades, ~~the Participating TO shall refund~~ identified in Appendix A-3, SDG&E shall be responsible for refunding to the Interconnection Customer any amount by which the actual payment by the Interconnection Customer for estimated costs of such facilities exceeds the actual costs of construction ~~multiplied by the Interconnection Customer's percentage share of those costs, as set forth in Appendix G to this LGIA,~~ within thirty (30) Calendar Days of the issuance of such final construction invoice. In the event the actual costs of construction multiplied by the Interconnection Customer's percentage share of those costs exceed the Interconnection Customer's actual payment for estimated costs, then ~~the Participating TO~~ SDG&E shall ~~recover~~ be responsible for recovering such difference through its transmission service rates.

Invoices shall be provided separately for Phase A of the Interconnection Project and Phase B of the Interconnection Project.

- 12.3 Payment.** Invoices shall be rendered to the ~~Interconnection Customer~~ paying Party at the address specified in Appendix F. The ~~Interconnection Customer~~ Party receiving the invoice shall pay, ~~or Participating TO shall refund, the amounts due the invoice~~ within thirty (30) Calendar Days of ~~the Interconnection Customer's receipt of the invoice.~~ All payments shall be made in immediately available funds payable to the ~~Interconnection Customer or Participating TO~~ other Party, or by wire transfer to a bank named and account designated by the invoicing ~~Interconnection Customer or Participating TO~~ Party. Payment of invoices by ~~any~~ either Party will not constitute a waiver of any rights or claims ~~any~~ either Party may have under this ~~LGIA.~~ Agreement.
- 12.4 Disputes.** In the event of a billing dispute between ~~the~~ Transmission Owners and Interconnection Customer ~~and the Participating TO, the Participating TO,~~ Transmission Owners and the CAISO shall continue to provide Interconnection Service under this ~~LGIA~~ Agreement as long as ~~the~~ Interconnection Customer: (i) continues to make all payments not in dispute; and (ii) pays to ~~the Participating TO~~ Transmission

Owners or into an independent escrow account the portion of the invoice in dispute, pending resolution of such dispute. If ~~the~~ Interconnection Customer fails to meet these two requirements for continuation of service, then ~~the Participating TO~~ Transmission Owners may provide notice to ~~the~~ Interconnection Customer of a Default pursuant to Article 17. Within thirty (30) Calendar Days after the resolution of the dispute, the Party that owes money to the other Party shall pay the amount due with interest calculated in ~~accordance~~ accord with the methodology set forth in FERC's ~~Regulations~~ regulations at 18 ~~C.F.R.~~ CFR § 35.19a(a)(2)(iii). Notwithstanding the foregoing, any billing dispute between the CAISO ~~and another Party~~, Interconnection Customer and/or SDG&E shall be resolved in accordance with the provisions of Article 27 of this ~~LGIA~~ Agreement.

ARTICLE 13. EMERGENCIES

Article 13. Emergencies

~~13.1~~ [Reserved]

13.1 Definition. "Emergency Condition" shall have the meaning set forth in Article 1.

- 13.2 Obligations.** ~~Each Party~~ Interconnection Customer, SDG&E and the CAISO shall comply with the Emergency Condition procedures of the CAISO, and all Parties shall comply with the Emergency Condition procedures of NERC, the Applicable Reliability Council, Applicable Reliability Standards, Applicable Laws and Regulations, and any emergency procedures set forth in this ~~LGIA~~ Agreement or agreed to by the Joint Operating Committee that are consistent with the other Emergency Condition procedures with which compliance is required by this Article 13.2.
- 13.3 Notice.** ~~The Participating TO~~ With respect to any facility which a Transmission Owner or the CAISO controls, the Transmission Owner or the CAISO shall notify ~~the~~ Interconnection Customer promptly when it becomes aware of an Emergency Condition that affects ~~the Participating TO's~~ Transmission Owners' Interconnection Facilities or ~~Distribution System~~ such Transmission Owner's or the CAISO ~~Controlled Grid, respectively,~~ s Transmission System that may reasonably be expected to affect ~~the~~ Interconnection Customer's operation of the Large Generating Facility or ~~the~~ Interconnection Customer's Interconnection Facilities. ~~The~~ Interconnection Customer shall notify ~~the Participating TO~~ Transmission Owners and the CAISO promptly when it becomes aware of an Emergency Condition that affects the Large Generating Facility or ~~the~~ Interconnection Customer's Interconnection Facilities that may reasonably be expected to affect the ~~CAISO Controlled Grid or the Participating TO's~~ Transmission Systems or Transmission Owners' Interconnection Facilities. To the extent information is known, the notification shall describe the Emergency Condition, the extent of the damage or deficiency, the expected effect on the operation of ~~the~~ Interconnection Customer's or ~~Participating TO~~ such Transmission Owner's or the CAISO's facilities and operations, its anticipated duration and the corrective action taken and/or to be taken. The initial notice shall be followed as soon as practicable with written notice, if requested by a Party, which may be provided by electronic mail or facsimile, or in the case of the CAISO may be publicly posted on the CAISO's internet ~~web~~ site website.

13.4 Immediate Action. Unless, in ~~the~~ Interconnection Customer's reasonable judgment, immediate action is required, ~~the~~ Interconnection Customer shall obtain the consent of APS and the CAISO ~~and the Participating TO~~, such consent to not be unreasonably withheld, prior to performing any manual switching operations at the Large Generating Facility or ~~the~~ Interconnection Customer's Interconnection Facilities in response to an Emergency Condition either declared by ~~the Participating TO~~ APS, on behalf of the Transmission Owners, or the CAISO or ~~in response to any other emergency condition otherwise regarding the Transmission Systems.~~

13.5 CAISO Transmission Owner and ~~Participating TO~~ CAISO Authority.

13.5.1 General. ~~The~~ Transmission Owners and the CAISO ~~and Participating TO~~ may take whatever actions or inactions, ~~including issuance of dispatch instructions,~~ with regard to ~~the CAISO Controlled Grid or the Participating TO's~~ their affected Transmission Systems or Transmission Owners' Interconnection Facilities ~~or Distribution System~~ they deem necessary during an Emergency Condition in order to (i) preserve public health and safety, (ii) preserve the reliability of the ~~CAISO Controlled Grid or the Participating TO's~~ affected Transmission Systems or Transmission Owners' Interconnection Facilities ~~or Distribution System, and,~~ (iii) limit or prevent damage, and (iv) expedite restoration of service.

~~The Participating TO~~ Transmission Owners and the CAISO shall use Reasonable Efforts to minimize the effect of such actions or inactions on the Large Generating Facility or ~~the~~ Interconnection Customer's Interconnection Facilities. ~~The Participating TO or~~ APS, on behalf of Transmission Owners, and the CAISO may, on the basis of technical considerations, require the Large Generating Facility to mitigate an Emergency Condition by taking actions necessary and limited in scope to remedy the Emergency Condition, including, but not limited to, directing ~~the~~ Interconnection Customer to shut-down, start-up, increase or decrease the real or reactive power output of the Large Generating Facility; implementing a reduction or disconnection pursuant to Article 13.5.2; directing ~~the~~ Interconnection Customer to assist with ~~black start~~ blackstart (if available) or restoration efforts; or altering the outage schedules of the Large Generating Facility and ~~the~~ Interconnection Customer's Interconnection Facilities. Subject to the provisions of Articles 9.6.1 and 9.6.2, Interconnection Customer shall comply with all of ~~the CAISO's and Participating TO~~ APS's operating instructions concerning Large Generating Facility real power and reactive power output within the manufacturer's design limitations of the Large Generating Facility's equipment that is in service and physically available for operation at the time, in compliance with Applicable Laws and Regulations and Applicable Reliability Standards.

13.5.2 Reduction and Disconnection. ~~The Participating TO~~ APS, on behalf of Transmission Owners, or the CAISO may reduce Interconnection Service ~~of, and APS may~~ disconnect the Large Generating Facility or ~~the~~ Interconnection Customer's Interconnection Facilities, when such reduction or disconnection is

necessary under Good Utility Practice due to Emergency Conditions. These rights are separate and distinct from any right of curtailment of Transmission Owners or the CAISO pursuant to ~~the CAISO Tariff. When the CAISO or Participating TO~~ their respective Tariffs. When APS, on behalf of Transmission Owners, or the CAISO can schedule the reduction or disconnection in advance, APS or the CAISO ~~or Participating TO~~ shall notify ~~the~~ Interconnection Customer of the reasons, timing and expected duration of the reduction or disconnection. ~~The CAISO or Participating TO~~ and shall coordinate with the other in accordance with Articles 9.7.1 and 9.7.2. APS and the CAISO shall coordinate with ~~the~~ Interconnection Customer using Good Utility Practice to schedule the reduction or disconnection during periods of least impact to ~~the~~ Interconnection Customer and Transmission Owners and the CAISO ~~and Participating TO~~. Any reduction or disconnection shall continue only for so long as reasonably necessary under Good Utility Practice. The Parties shall cooperate with each other to restore the Large Generating Facility, the Interconnection Facilities, and the ~~CAISO Controlled Grid~~ Transmission System to their normal operating state as soon as practicable consistent with Good Utility Practice.

13.6 Interconnection Customer Authority. Consistent with Good Utility Practice, this LGIA Agreement and ~~the CAISO Tariff, the applicable Tariffs,~~ Interconnection Customer may take actions or inactions with regard to the Large Generating Facility or ~~the~~ Interconnection Customer's Interconnection Facilities during an Emergency Condition in order to (i) preserve public health and safety, (ii) preserve the reliability of the Large Generating Facility or ~~the~~ Interconnection Customer's Interconnection Facilities, (iii) limit or prevent damage, and (iv) expedite restoration of service. Interconnection Customer shall use Reasonable Efforts to minimize the effect of such actions or inactions on the ~~CAISO Controlled Grid and the Participating TO's~~ affected Transmission System(s) and Transmission Owners' Interconnection Facilities. The CAISO and Participating TO Each affected Transmission Owner and the CAISO shall use Reasonable Efforts to assist Interconnection Customer in such actions.

13.7 Limited Liability. Except as otherwise provided in Article 11.6.1 of this LGIA Agreement, no Party shall be liable to ~~any other Party~~ the others for any action it takes in responding to an Emergency Condition so long as such action is made in good faith and is consistent with Good Utility Practice.

~~ARTICLE 14. REGULATORY REQUIREMENTS AND GOVERNING LAW~~ Article 14. Regulatory Requirements and Governing Law

14.1 Regulatory Requirements. Each Party's obligations under this LGIA Agreement shall be subject to its receipt of any required approval or certificate from one or more Governmental Authorities in the form and substance satisfactory to the applying Party, or the Party making any required filings with, or providing notice to, such Governmental Authorities, and the expiration of any time period associated therewith. Each Party shall in good faith seek and use its Reasonable Efforts to obtain such other approvals. Nothing in this LGIA Agreement shall require ~~the~~ Interconnection Customer or other

Party to take any action that could result in its inability to obtain, or its loss of, status or exemption under the Federal Power Act ~~or~~ the Public Utility Holding Company Act of 1935, as amended, or the Public Utility Regulatory Policies Act of ~~1978, or the Energy Policy Act of 2005.~~ 1978.

14.2 Governing Law.

14.2.1 The validity, interpretation and performance of this LGIA Agreement and each of its provisions shall be governed by the laws of the state where the Point of Interconnection is located, without regard to its conflicts of law principles.

14.2.2 This LGIA Agreement is subject to all Applicable Laws and Regulations.

14.2.3 Each Party expressly reserves the right to seek changes in, appeal, or otherwise contest any laws, orders, rules, or regulations of a Governmental Authority.

ARTICLE 15. NOTICES

Article 15. Notices.

15.1 **General.** Unless otherwise provided in this LGIA Agreement, any notice, demand or request required or permitted to be given by a Party to ~~another~~ the others and any instrument required or permitted to be tendered or delivered by a Party in writing to ~~another~~ the others shall be effective when delivered and may be so given, tendered or delivered, by recognized national courier, or by depositing the same with the United States Postal Service with postage prepaid, for delivery by certified or registered mail, addressed to the ~~Party~~ Parties, or personally delivered to the ~~Party~~ Parties, at the address set out in Appendix F, Addresses for Delivery of Notices and Billings.

A Party must update the information in Appendix F as information changes. A Party may change the notice information in this LGIA Agreement by giving five (5) Business Days written notice prior to the effective date of the change. Such changes shall not constitute an amendment to this LGIA Agreement.

15.2 **Billings and Payments.** Billings and payments shall be sent to the addresses set out in Appendix F.

15.3 **Alternative Forms of Notice.** Any notice or request required or permitted to be given by a Party to ~~another~~ the other and not required by this LGIA Agreement to be given in writing may be so given by telephone, facsimile or ~~e-mail~~ email to the telephone numbers and ~~e-mail~~ email addresses set out in Appendix F.

15.4 **Operations and Maintenance Notice.** ~~Each Party~~ APS and the CAISO shall notify the other Parties in writing of the identity of the person(s) that ~~it designates~~ they designate as the point(s) of contact with respect to the implementation of Articles 9 and 10.

ARTICLE 16. FORCE MAJEURE

Article 16. Force Majeure

16.1 Force Majeure.

16.1.1 Economic hardship is not considered a Force Majeure event.

16.1.2 No Party shall be considered to be in Default with respect to any obligation hereunder, (including obligations under Article 4), other than the obligation to pay money when due, if prevented from fulfilling such obligation by Force Majeure. A Party unable to fulfill any obligation hereunder (other than an obligation to pay money when due) by reason of Force Majeure shall give notice and the full particulars of such Force Majeure to the other ~~Party~~Parties in writing or by telephone as soon as reasonably possible after the occurrence of the cause relied upon. Telephone notices given pursuant to this ~~Article~~article shall be confirmed in writing as soon as reasonably possible and shall specifically state full particulars of the Force Majeure, the time and date when the Force Majeure occurred and when the Force Majeure is reasonably expected to cease. The Party affected shall exercise due diligence to remove such disability with reasonable dispatch, but shall not be required to accede or agree to any provision not satisfactory to it in order to settle and terminate a strike or other labor disturbance.

~~ARTICLE 17. DEFAULT~~

Article 17. Default

17.1 ~~Default-~~

17.1.1 **General.** No Default shall exist where such failure to discharge an obligation (other than the payment of money or posting of security) is the result of Force Majeure as defined in this ~~LGIA~~Agreement or the result of an act ~~or of~~ omission of the other ~~Party~~Parties. Upon a Breach, the affected non-Breaching ~~Party(ies)~~Parties shall give written notice of such Breach to the Breaching Party. Except as provided in Article 17.1.2, the Breaching Party shall have thirty (30) Calendar Days from receipt of the Default notice within which to cure such Breach; provided however, if such Breach is not capable of cure within thirty (30) Calendar Days, the Breaching Party shall commence such cure within thirty (30) Calendar Days after notice and continuously and diligently complete such cure within ninety (90) Calendar Days from receipt of the Default notice; and, if cured within such time, the Breach specified in such notice shall cease to exist. If one but not both of the entities comprising the Interconnection Customer breaches this Agreement, the non-Breaching Party shall accept performance from the Interconnection Customer entity to the extent it continues to perform under this Agreement.

17.1.2 **Right to Terminate.** If a Breach is not cured as provided in this ~~Article~~article or as provided in Article 11.5.3 with respect to the posting of financial security, or if a Breach is not capable of being cured within the period provided for herein, ~~the~~an affected non-Breaching Party ~~(ies)~~ shall have the right to declare a Default and terminate this ~~LGIA~~Agreement by written notice at any time until cure occurs, and be relieved of any further obligation hereunder and, whether or not

~~such that~~ Party(~~ies~~) terminates this LGIA Agreement, to recover from the Breaching Party all amounts due hereunder, plus all other damages and remedies to which it is entitled at law or in equity. The provisions of this ~~Article~~article will survive termination of this LGIA Agreement.

~~ARTICLE 18. INDEMNITY, CONSEQUENTIAL DAMAGES AND INSURANCE~~
Article 18. Indemnity, Consequential Damages and Insurance

18.1 Indemnity. ~~Each~~A Party shall at all times indemnify, defend, and hold ~~the other Parties~~another Party, harmless from, any and all Losses arising out of or resulting from ~~another~~that particular Party's ~~action's~~actions or inactions of its obligations under this LGIA Agreement on behalf of the indemnifying Party, except in cases of gross negligence or intentional wrongdoing by the ~~Indemnified~~indemnified Party.

18.1.1 Indemnified Party. If an ~~Indemnified~~indemnified Party is entitled to indemnification under this Article 18 as a result of a claim by a third party, and the ~~Indemnifying~~indemnifying Party fails, after notice and reasonable opportunity to proceed under Article 18.1, to assume the defense of such claim, such ~~Indemnified~~indemnified Party may at the expense of the ~~Indemnifying~~indemnifying Party contest, settle or consent to the entry of any judgment with respect to, or pay in full, such claim.

18.1.2 Indemnifying Party. If an ~~Indemnifying~~indemnifying Party is obligated to indemnify and hold any ~~Indemnified~~indemnified Party harmless under this Article 18, the amount owing to the ~~Indemnified~~indemnified Party shall be the amount of such ~~Indemnified~~indemnified Party's actual Loss, net of any insurance or other recovery.

18.1.3 Indemnity Procedures. Promptly after receipt by an ~~Indemnified~~indemnified Party of any claim or notice of the commencement of any action or administrative or legal proceeding or investigation as to which the indemnity provided for in Article 18.1 may apply, the ~~Indemnified~~indemnified Party shall notify the ~~Indemnifying~~indemnifying Party of such fact. Any failure of or delay in such notification shall not affect a Party's indemnification obligation unless such failure or delay is materially prejudicial to the indemnifying Party.

The ~~Indemnifying~~indemnifying Party shall have the right to assume the defense thereof with counsel designated by such ~~Indemnifying~~indemnifying Party and reasonably satisfactory to the ~~Indemnified~~indemnified Party. If the defendants in any such action include one or more ~~Indemnified~~indemnified Parties and the ~~Indemnifying~~indemnifying Party and if the ~~Indemnified~~indemnified Party reasonably concludes that there may be legal defenses available to it and/or other ~~Indemnified~~indemnified Parties which are different from or additional to those available to the ~~Indemnifying~~indemnifying Party, the ~~Indemnified~~indemnified Party shall have the right to select separate counsel to assert such legal defenses and to otherwise participate in the defense of such action on its own behalf. In such instances, the ~~Indemnifying~~indemnifying

Party shall only be required to pay the fees and expenses of one additional attorney to represent an ~~Indemnified~~indemnified Party or ~~Indemnified~~indemnified Parties having such differing or additional legal defenses.

The ~~Indemnified~~indemnified Party shall be entitled, at its expense, to participate in any such action, suit or proceeding, the defense of which has been assumed by the ~~Indemnifying~~indemnifying Party. Notwithstanding the foregoing, the ~~Indemnifying~~indemnifying Party (i) shall not be entitled to assume and control the defense of any such action, suit or proceedings if and to the extent that, in the opinion of the ~~Indemnified~~indemnified Party and its counsel, such action, suit or proceeding involves the potential imposition of criminal liability on the ~~Indemnified~~indemnified Party, or there exists a conflict or adversity of interest between the ~~Indemnified~~indemnified Party and the ~~Indemnifying~~indemnifying Party, in such event the ~~Indemnifying~~indemnifying Party shall pay the reasonable expenses of the ~~Indemnified~~indemnified Party, and (ii) shall not settle or consent to the entry of any judgment in any action, suit or proceeding without the consent of the ~~Indemnified~~indemnified Party, which shall not be ~~unreasonably~~reasonably withheld, conditioned or delayed.

18.2 Consequential Damages. ~~Other than the liquidated damages heretofore described in Article 5.3, in~~In no event shall ~~any~~a Party be liable under any provision of this ~~LGIA Agreement~~ for any losses, damages, costs or expenses for any special, indirect, incidental, consequential, or punitive damages, including but not limited to loss of profit or revenue, loss of the use of equipment, cost of capital, cost of temporary equipment or services, whether based in whole or in part in contract, in tort, including negligence, strict liability, or any other theory of liability; provided, however, that damages for which a Party may be liable to another Party under another agreement will not be considered to be special, indirect, incidental, or consequential damages hereunder.

18.3 Insurance. ~~Each~~A Party shall, at its own expense, maintain in force throughout the period of this ~~LGIA Agreement~~, and until released by the other ~~Parties~~Party(ies), the following minimum insurance coverages, with insurers ~~rated no less than A (with a minimum size rating of VII) by Bests' Insurance Guide and Key Ratings and~~ authorized to do business in the state where the Point of Interconnection is located; ~~except in the case of the CAISO, the State of California:~~

18.3.1 Employer's Liability and Workers' Compensation Insurance providing statutory benefits in accordance with the laws and regulations of the state in which the Point of Interconnection is located, except in the case of the CAISO, the State of California.

18.3.2 Commercial General Liability Insurance including premises and operations, personal injury, broad form property damage, broad form blanket contractual liability coverage (including coverage for the contractual indemnification) products and completed operations coverage, coverage for explosion, collapse and underground hazards, independent contractors coverage, coverage for

pollution to the extent normally available and punitive damages to the extent normally available and a cross liability endorsement, with minimum limits of One Million Dollars (\$1,000,000) per occurrence/One Million Dollars (\$1,000,000) aggregate combined single limit for personal injury, bodily injury, including death and property damage.

- 18.3.3** Business Automobile Liability Insurance for coverage of owned and non-owned and hired vehicles, trailers or semi-trailers designed for travel on public roads, with a minimum, combined single limit of One Million Dollars (\$1,000,000) per occurrence for bodily injury, including death, and property damage.
- 18.3.4** Excess Public Liability Insurance over and above the Employer's Liability Commercial General Liability and Business Automobile Liability Insurance coverage, with a minimum combined single limit of Twenty Million Dollars (\$20,000,000) per occurrence/Twenty Million Dollars (\$20,000,000) aggregate.
- 18.3.5** The Commercial General Liability Insurance, Business Automobile Insurance and Excess Public Liability Insurance policies shall name the other **Parties** Party, their parents, associated and Affiliate companies and their respective directors, officers, agents, servants and employees ("Other Party Group") as additional insured. All policies shall contain provisions whereby the insurers waive all rights of subrogation in accordance with the provisions of this **LGIA Agreement** against the Other Party Group and provide thirty (30) Calendar Days advance written notice to the Other Party Group prior to anniversary date of cancellation or any material change in coverage or condition.
- 18.3.6** The Commercial General Liability Insurance, Business Automobile Liability Insurance and Excess Public Liability Insurance policies shall contain provisions that specify that the policies are primary and shall apply to such extent without consideration for other policies separately carried and shall state that each insured is provided coverage as though a separate policy had been issued to each, except the insurer's liability shall not be increased beyond the amount for which the insurer would have been liable had only one insured been covered. Each Party shall be responsible for its respective deductibles or retentions.
- 18.3.7** The Commercial General Liability Insurance, Business Automobile Liability Insurance and Excess Public Liability Insurance policies, if written on a Claims First Made Basis, shall be maintained in full force and effect for two (2) years after termination of this **LGIA Agreement**, which coverage may be in the form of tail coverage or extended reporting period coverage if agreed by the Parties.
- 18.3.8** The requirements contained herein as to the types and limits of all insurance to be maintained by the Parties are not intended to and shall not in any manner, limit or qualify the liabilities and obligations assumed by the Parties under this **LGIA Agreement**.
- 18.3.9** Within ten (10) Calendar Days following execution of this **LGIA Agreement**, and as soon as practicable after the end of each fiscal year or at the renewal of the insurance policy and in any event within ninety (90) Calendar Days thereafter,

each Party shall provide certification of all insurance required in this [LGIA Agreement](#), executed by each insurer or by an authorized representative of each insurer.

18.3.10 Notwithstanding the foregoing, each Party may self-insure to meet the minimum insurance requirements of Articles 18.3.2 through 18.3.8 to the extent it maintains a self-insurance program; provided that, such Party's senior unsecured debt or issuer rating is BBB-, or better, as rated by Standard & Poor's and that its self-insurance program meets the minimum insurance requirements of Articles 18.3.2 through 18.3.8. For any period of time that a Party's senior unsecured debt rating and issuer rating ~~are both unrated by Standard & Poor's or~~ are both rated at less than BBB- by Standard & Poor's, such Party shall comply with the insurance requirements applicable to it under Articles 18.3.2 through 18.3.9. In the event that a Party is permitted to self-insure pursuant to this ~~Article 18.3.10, article~~, it shall notify the other Parties that it meets the requirements to self-insure and that its self-insurance program meets the minimum insurance requirements in a manner consistent with that specified in Article 18.3.9.

18.3.11 The Parties agree to report to each other in writing as soon as practical all accidents or occurrences resulting in injuries to any person, including death, and any property damage arising out of this [LGIA Agreement](#).

~~ARTICLE 19. ASSIGNMENT~~

Article 19. Assignment

19.1 Assignment. This [LGIA Agreement](#) may be assigned by a Party only with the written consent of the other Parties; provided that a Party may assign this [LGIA Agreement](#) without the consent of the other Parties to any Affiliate of the assigning Party with an equal or greater credit rating and with the legal authority and operational ability to satisfy the obligations of the assigning Party under this [LGIA Agreement](#); and provided further that ~~the~~ Interconnection Customer shall have the right to assign this [LGIA Agreement](#), without the consent of the ~~CAISO or Participating TO~~ other Parties, for collateral security purposes to aid in providing financing for the Large Generating Facility or a Project Phase of the Large Generating Facility, provided that ~~the~~ Interconnection Customer will promptly notify the ~~CAISO and Participating TO~~ Parties of any such assignment. Any financing arrangement entered into by ~~the~~ Interconnection Customer pursuant to this ~~Article~~ article will provide that prior to or upon the exercise of the secured party's, trustee's or mortgagee's assignment rights pursuant to said arrangement, the secured creditor, the trustee or mortgagee will notify the ~~CAISO and Participating TO~~ Parties of the date and particulars of any such exercise of assignment right(s), including providing the ~~CAISO and Participating TO~~ Parties with proof that it meets the requirements of Articles 11.5 and 18.3. Any attempted assignment that violates this ~~Article~~ article is void and ineffective. Any assignment under this [LGIA Agreement](#) shall not relieve a Party of its obligations, nor shall a Party's obligations be enlarged, in whole or in part, by reason thereof. Where required, consent to assignment will not be unreasonably withheld, conditioned or delayed.

ARTICLE 20. SEVERABILITY

Article 20. Severability

- 20.1 Severability.** If any provision in this LGIA Agreement is finally determined to be invalid, void or unenforceable by any court or other Governmental Authority having jurisdiction, such determination shall not invalidate, void or make unenforceable any other provision, agreement or covenant of this LGIA Agreement; provided that if ~~the~~ Interconnection Customer (or any third party, but only if such third party is not acting at the direction of ~~the Participating TO or a~~ Transmission Owner or the CAISO) seeks and obtains such a final determination with respect to any provision of the Alternate Option (Article 5.1.2), or the Negotiated Option (Article 5.1.4), then none of ~~the~~ these provisions ~~of Article 5.1.2 or 5.1.4~~ shall thereafter have any force or effect and the Parties' rights and obligations shall be governed solely by the Standard Option (Article 5.1.1).

ARTICLE 21. COMPARABILITY

Article 21. Comparability

- 21.1 Comparability.** The Parties which are FERC-jurisdictional public utilities will comply with all applicable comparability and code of conduct laws, rules and regulations, as amended from time to time. For clarity and avoidance of ambiguity, IID is not a jurisdictional public utility to whom Section 205 or 206 of the Federal Power Act or FERC rules and regulations thereunder apply.

ARTICLE 22. CONFIDENTIALITY

Article 22. Confidentiality

- 22.1 Confidentiality.** Confidential Information shall include, without limitation, all information relating to a Party's technology, research and development, business affairs, and pricing, and any information supplied by any of the Parties to the other ~~Parties~~ prior to the execution of this LGIA Agreement.

Information is Confidential Information only if it is clearly designated or marked in writing as confidential on the face of the document, or, if the information is conveyed orally or by inspection, if the Party providing the information orally informs the Parties receiving the information that the information is confidential.

If requested by any Party, the other Parties shall provide in writing, the basis for asserting that the information referred to in this Article 22 warrants confidential treatment, and the requesting Party may disclose such writing to the appropriate Governmental Authority. Each Party shall be responsible for the costs associated with affording confidential treatment to its information.

- 22.1.1 Term.** During the term of this LGIA Agreement, and for a period of three (3) years after the expiration or termination of this LGIA Agreement, except as otherwise provided in this Article 22, each Party shall hold in confidence and shall not disclose to any person Confidential Information.

- 22.1.2 Scope.** Confidential Information shall not include information that the receiving Party can demonstrate: (1) is generally available to the public other than as a result of a disclosure by the receiving Party; (2) was in the lawful possession of the receiving Party on a non-~~confidential~~ basis before receiving it from the disclosing Party; (3) was supplied to the receiving Party without restriction by a third party, who, to the knowledge of the receiving Party after due inquiry, was under no obligation to the disclosing Party to keep such information confidential; (4) was independently developed by the receiving Party without reference to Confidential Information of the disclosing Party; (5) is, or becomes, publicly known, through no wrongful act or omission of the receiving Party or Breach of this ~~LGIA Agreement~~; or (6) is required, in accordance with Article 22.1.7 of ~~this LGIA the Agreement~~, Order of Disclosure, to be disclosed by any Governmental Authority or is otherwise required to be disclosed by law or subpoena, or is necessary in any legal proceeding establishing rights and obligations under this ~~LGIA Agreement~~. Information designated as Confidential Information will no longer be deemed confidential if the Party that designated the information as confidential notifies the other Parties that it no longer is confidential.
- 22.1.3 Release of Confidential Information.** No Party shall release or disclose Confidential Information to any other person, except to its ~~employees, consultants,~~ Affiliates (limited by the Standards of Conduct requirements set forth in Part 358 of FERC's Regulations, 18 C.F.R. 358), subcontractors, ~~employees, consultants,~~ or to parties who may be or considering providing financing to or equity participation with ~~the~~ Interconnection Customer, or to potential purchasers or assignees of ~~the~~ Interconnection Customer, on a need-~~to~~-know basis in connection with this ~~LGIA Agreement~~, unless such person has first been advised of the confidentiality provisions of this Article 22 and has agreed to comply with such provisions. Notwithstanding the foregoing, a Party providing Confidential Information to any person shall remain primarily responsible for any release of Confidential Information in contravention of this Article 22.
- 22.1.4 Rights.** Each Party retains all rights, title, and interest in the Confidential Information that each Party discloses to the other Parties. The disclosure by each Party to the other Parties of Confidential Information shall not be deemed a waiver by a Party or any other person or entity of the right to protect the Confidential Information from public disclosure.
- 22.1.5 No Warranties.** ~~The mere fact that a Party has provided~~ ~~By providing~~ Confidential Information ~~does not constitute a warranty or representation,~~ ~~no Party makes any warranties or representations~~ as to its accuracy or completeness. In addition, by supplying Confidential Information, no Party obligates itself to provide any particular information or Confidential Information to the other Parties nor to enter into any further agreements or proceed with any other relationship or joint venture.

- 22.1.6 Standard of Care.** ~~Each~~^A Party shall use at least the same standard of care to protect Confidential Information it receives as it uses to protect its own Confidential Information from unauthorized disclosure, publication or dissemination. ~~Each~~^A Party may use Confidential Information solely to fulfill its obligations to the other Parties under this [LGIA Agreement](#) or its regulatory requirements.
- 22.1.7 ~~Order of Disclosure~~ [Required by Law or Order](#).** If a court or a Government Authority or entity with the right, power, and apparent authority to do so requests or requires ~~any~~^a Party, by subpoena, oral deposition, interrogatories, requests for production of documents, administrative order, or otherwise, to disclose Confidential Information, that Party shall provide the other Parties with prompt notice of such request(s) or requirement(s) so that the other Parties may seek an appropriate protective order or waive compliance with the terms of this [LGIA Agreement](#). Notwithstanding the absence of a protective order or waiver, the Party may disclose such Confidential Information which, in the opinion of its counsel, the Party is legally compelled to disclose. ~~Each, including any Confidential Information that, in the opinion of IID's counsel, IID is legally compelled to disclose under California public record laws.~~ ^A Party will use Reasonable Efforts to obtain reliable assurance that confidential treatment will be accorded any Confidential Information so furnished.
- 22.1.8 Termination of Agreement.** Upon termination of this [LGIA Agreement](#) for any reason, each Party shall, within ten (10) Calendar Days of receipt of a written request from another Party, use Reasonable Efforts to destroy, erase, or delete (with such destruction, erasure, and deletion certified in writing to the other ~~Party~~^{Parties}) or return to ~~the other~~^{another} Party, without retaining copies thereof, any and all written or electronic Confidential Information received from the other Party.
- 22.1.9 Remedies.** The Parties agree that monetary damages would be inadequate to compensate a Party for another Party's Breach of its obligations under this Article 22. Each Party accordingly agrees that the other Parties shall be entitled to equitable relief, by way of injunction or otherwise, if the first Party Breaches or threatens to Breach its obligations under this Article 22, which equitable relief shall be granted without bond or proof of damages, and the receiving Party shall not plead in defense that there would be an adequate remedy at law. Such remedy shall not be deemed an exclusive remedy for the Breach of this Article 22, but shall be in addition to all other remedies available at law or in equity. The Parties further acknowledge and agree that the covenants contained herein are necessary for the protection of legitimate business interests and are reasonable in scope. No Party, however, shall be liable for indirect, incidental, or consequential or punitive damages of any nature or kind resulting from or arising in connection with this Article 22.
- 22.1.10 Disclosure to FERC, its Staff, or a State.** Notwithstanding anything in this Article 22 to the contrary, and pursuant to 18 ~~C.F.R.~~^{CFR} section 1b.20, if FERC or its staff, during the course of an investigation or otherwise, requests information from one of the Parties that is otherwise required to be maintained in

confidence pursuant to this [LGIA Agreement](#), the Party shall provide the requested information to FERC or its staff, within the time provided for in the request for information. In providing the information to FERC or its staff, the Party must, consistent with 18 [C.F.R. CFR](#) section 388.112, request that the information be treated as confidential and non-public by FERC and its staff and that the information be withheld from public disclosure. Parties are prohibited from notifying the other [Parties Party](#) to this [LGIA Agreement](#) prior to the release of the Confidential Information to FERC or its staff. The Party shall notify the other Parties to the [LGIA Agreement](#) when it is notified by FERC or its staff that a request to release Confidential Information has been received by FERC, at which time any of the Parties may respond before such information would be made public, pursuant to 18 [C.F.R. CFR](#) section 388.112. Requests from a state regulatory body conducting a confidential investigation shall be treated in a similar manner if consistent with the applicable state rules and regulations.

- 22.1.11** Subject to the exception in Article 22.1.10, Confidential Information shall not be disclosed by the other Parties to any person not employed or retained by the other Parties, except to the extent disclosure is (i) required by law; (ii) reasonably deemed by the disclosing Party to be required to be disclosed in connection with a dispute between or among the Parties, or the defense of litigation or dispute; (iii) otherwise permitted by consent of the other Parties, such consent not to be unreasonably withheld; or (iv) necessary to fulfill its obligations under this [LGIA Agreement](#) or as a transmission service provider or a Balancing Authority including disclosing the Confidential Information to an RTO or ISO or to a regional or national reliability organization. The Party asserting confidentiality shall notify the other [Parties Party](#) in writing of the information it claims is confidential. Prior to any disclosures of another Party's Confidential Information under this subparagraph, or if any third party or Governmental Authority makes any request or demand for any of the information described in this subparagraph, the disclosing Party agrees to promptly notify the other Party in writing and agrees to assert confidentiality and cooperate with the other Party in seeking to protect the Confidential Information from public disclosure by confidentiality agreement, protective order or other reasonable measures.

~~ARTICLE 23. ENVIRONMENTAL RELEASES~~

Article 23. Environmental Releases

- 23.1** Each Party shall notify the other Parties, first orally and then in writing, of the release of any Hazardous Substances, any asbestos or lead abatement activities, or any type of remediation activities related to the Large Generating Facility or the Interconnection Facilities, each of which may reasonably be expected to affect the other [Parties Party](#). The notifying Party shall: (i) provide the notice as soon as practicable, provided such [Party Parties](#) makes a good faith effort to provide the notice no later than twenty-four hours after such Party becomes aware of the occurrence; and (ii) promptly furnish to the other Parties copies of any publicly available reports filed with any Governmental Authorities addressing such events.

ARTICLE 24. INFORMATION REQUIREMENTS

Article 24. Information Requirements

- 24.1 Information Acquisition.** ~~The Participating TO~~ APS, on behalf of Transmission Owners, and ~~the~~ Interconnection Customer shall submit specific information regarding the electrical characteristics of their respective facilities to each other as described below and in accordance with Applicable Reliability Standards.
- 24.2 Information Submission by ~~Participating TO~~ APS, on behalf of Transmission Owners.** The initial information submission by ~~the Participating TO~~ APS, on behalf of Transmission Owners, shall occur no later than one hundred eighty (180) Calendar Days prior to Trial Operation of a Project Phase and shall include ~~the Participating TO's~~ Transmission System information necessary to allow ~~the~~ Interconnection Customer to select equipment and meet any system protection and stability requirements, unless otherwise agreed to by the ~~Participating TO and the Interconnection Customer~~ Parties. On a monthly basis ~~the Participating TO~~ APS, on behalf of Transmission Owners, shall provide ~~the~~ Interconnection Customer and the CAISO a status report on the construction and installation of ~~the Participating TO's~~ Transmission Owners' Interconnection Facilities and Network Upgrades, including, but not limited to, the following information: (1) progress to date; (2) a description of the activities since the last report; (3) a description of the action items for the next period; and (4) the delivery status of equipment ordered.
- 24.3 Updated Information Submission by Interconnection Customer.** The updated information submission by ~~the~~ Interconnection Customer, including manufacturer information, shall occur no later than one hundred eighty (180) Calendar Days prior to the Trial Operation of a Project Phase. ~~The~~ Interconnection Customer shall submit a completed copy of the ~~Electric~~ Large Generating ~~Unit~~ Facility data requirements contained in Appendix 1 to the LGIP. It shall also include any additional updates to information provided to ~~the Participating TO~~ APS and ~~the~~ CAISO for the Interconnection ~~Studies~~ Feasibility, Interconnection Facilities Study, and the CAISO Phase II Interconnection Study, as applicable. Information in this submission shall be the most current ~~Electric~~ Large Generating ~~Unit~~ Facility design or expected performance data. Information submitted for stability models shall be compatible with ~~the~~ Participating TO APS's and ~~the~~ CAISO's standard models. If there is no compatible model, ~~the~~ Interconnection Customer will work with a consultant mutually agreed to by the Parties to develop and supply a standard model and associated information.
- If ~~the~~ Interconnection Customer's data is materially different from what was originally provided to ~~the Participating TO and the CAISO for the Interconnection Studies, then the Participating TO and~~ APS or the CAISO pursuant to the Interconnection Study Agreements between APS or the CAISO and Interconnection Customer, then APS or the CAISO, as applicable, will conduct appropriate studies ~~pursuant to the LGIP~~ to determine the impact on the ~~Participating TO's~~ Transmission System ~~and affected portions of the CAISO Controlled Grid~~ based on the actual data submitted pursuant to this Article 24.3. The Interconnection Customer

shall not begin Trial Operation of a Project Phase until such studies are completed and all other applicable requirements of this LGIA Agreement are satisfied.

If Interconnection Customer's data is materially different from what was originally provided to IID by the CAISO or by the Interconnection Customer pursuant to the Affected System Study Agreement, then IID also shall have the right, but not the obligation, to conduct any appropriate Affected System Study necessary to determine the impact on its non-JPP transmission facilities based on the actual data submitted pursuant to this Article 24.3. To the extent IID exercises this right, Interconnection Customer shall not begin Trial Operation of a Project Phase until such studies are completed and all other applicable requirements of this Agreement are satisfied.

- 24.4 Information Supplementation.** Prior to ~~the~~ Trial Operation ~~date~~ of a Project Phase, the Parties shall supplement their information submissions described above in this Article 24 with any and all ~~"as-built"~~ "Electric" Large Generating Unit Facility information or ~~"as-tested"~~ performance information that differs from the initial submissions or, alternatively, written confirmation that no such differences exist. The Interconnection Customer shall conduct tests on the Electric Large Generating Unit Facility as required by Good Utility Practice such as an open circuit ~~"step voltage"~~ test on the Electric Large Generating Unit Facility to verify proper operation of the Electric Large Generating Unit Facility's automatic voltage regulator.

Unless otherwise agreed, the test conditions shall include: (1) Electric Large Generating Unit Facility at synchronous speed; (2) automatic voltage regulator on and in voltage control mode; and (3) a five percent ~~(5 percent)~~ change in Electric Large Generating Unit Facility terminal voltage initiated by a change in the voltage regulators reference voltage. ~~The~~ Interconnection Customer shall provide validated test recordings showing the responses of Electric Large Generating Unit Facility terminal and field voltages. In the event that direct recordings of these voltages is impractical, recordings of other voltages or currents that mirror the response of the Electric Large Generating Unit Facility's terminal or field voltage are acceptable if information necessary to translate these alternate quantities to actual Electric Large Generating Unit Facility terminal or field voltages is provided. Electric Large Generating Unit Facility testing shall be conducted and results provided to ~~the Participating TO APS~~ and the CAISO ~~for each individual Electric Generating Unit in a station. at the request of APS and the CAISO.~~

Subsequent to the Commercial Operation Date for a Project Phase, ~~the~~ Interconnection Customer shall provide ~~the Participating TO APS~~ and the CAISO any information changes due to equipment replacement, repair, or adjustment. ~~The Participating TO APS, on behalf of Transmission Owners,~~ shall provide ~~the~~ Interconnection Customer any information changes due to equipment replacement, repair or adjustment in the directly connected substation or any adjacent Participating TO-owned Transmission Owners' substation that may affect ~~the~~ Interconnection Customer's Interconnection Facilities equipment ratings, protection or operating requirements. The Parties shall provide such information pursuant to Article 5.19.

~~ARTICLE 25. INFORMATION ACCESS AND AUDIT RIGHTS~~

Article 25. Information Access and Audit Rights

- 25.1 Information Access.** Each Party (the "disclosing Party") shall make available to the other PartyParties information that is in the possession of the disclosing Party and is necessary in order for the other PartyParties to: (i) verify the costs incurred by the disclosing Party for which ~~the other~~another Party is responsible under this LGIA Agreement; and (ii) carry out its obligations and responsibilities under this LGIA Agreement. The Parties shall not use such information for purposes other than those set forth in this Article 25.1 and to enforce their rights under this LGIA Agreement. Nothing in this Article 25 shall obligate ~~the CAISO~~a Party to make available to ~~a~~another Party any third party information in its possession or control if making such third party information available would violate a CAISO-Tariff or other legal restriction on the use or disclosure of such third party information.
- 25.2 Reporting of Non-Force Majeure Events.** Each Party (the "notifying Party") shall notify the other Parties when the notifying Party becomes aware of its inability to comply with the provisions of this LGIA Agreement for a reason other than a Force Majeure event. The Parties agree to cooperate with each other and provide necessary information regarding such inability to comply, including the date, duration, reason for the inability to comply, and corrective actions taken or planned to be taken with respect to such inability to comply. Notwithstanding the foregoing, notification, cooperation or information provided under this Articlearticle shall not entitle the PartyParties receiving such notification to allege a cause for anticipatory breach of this LGIA- Agreement.
- 25.3 Audit Rights.** Subject to the requirements of confidentiality under Article 22 of this LGIA, ~~the Parties' audit rights shall include audits of a Party' Agreement, each Party shall have the right, during normal business hours, and upon prior reasonable notice to the other Party, to audit at its own expense the other Party's accounts and records pertaining to either such Party's performance or either such Party's satisfaction of obligations under this Agreement. Such audit rights shall include audits of the other Party's costs pertaining to such Party's performance or satisfaction of obligations owed to the other Party under this LGIA owned to the other Party under this Agreement, calculation of invoiced amounts, APS's and the CAISO's efforts to allocate responsibility for the provision of reactive support to the CAISO Controlled Grid, Transmission System, Transmission Owners' and the CAISO's efforts to allocate responsibility for interruption or reduction of generation on the CAISO Controlled Grid, and each such Party' Transmission System, and each Party's actions in an Emergency Condition.~~**25.3.1** ~~—The Interconnection Customer and the Participating TO shall each have the right, during normal business hours, and upon prior reasonable notice to the other Party, to audit at its own expense the other Party's accounts and records pertaining to either such Party's performance or either such Party's satisfaction of obligations owed to the other Party under this LGIA. Subject to Article 25.3.2, any~~ Any audit authorized by this Articlearticle shall be performed at the offices where such accounts and records are maintained and shall be limited to those portions of such accounts and records that relate to each such Party's performance and satisfaction of obligations under

this [LGIA Agreement](#). Each such Party shall keep such accounts and records for a period equivalent to the audit rights periods described in Article 25.4. ~~25.3.2~~

~~————~~Notwithstanding anything to the contrary in Article ~~25.3, 25~~, each Party's rights to audit [APS's, IID's, SDG&E's](#) or the CAISO's accounts and records shall be ~~as set forth in Section 22.1 of the CAISO Tariff~~ [subject to their respective Tariffs](#).

25.4 Audit Rights Periods.

25.4.1 Audit Rights Period for Construction-Related Accounts and Records.

Accounts and records related to the design, engineering, procurement, and construction of ~~Participating TO's~~ [Transmission Owners'](#) Interconnection Facilities, ~~and~~ [Network Upgrades](#), ~~and Distribution Upgrades constructed by the Participating TO~~ shall be subject to audit for a period of twenty-four months following ~~the Participating TO's issuance of a~~ [issuances of final invoice](#) [invoices](#) in accordance with Article 12.2. ~~Accounts and records related to the design, engineering, procurement, and construction of Participating TO's Interconnection Facilities and/or Stand Alone Network Upgrades constructed by the Interconnection Customer shall be subject to audit and verification by the Participating TO and the CAISO for a period of twenty-four months following the Interconnection Customer's issuance of a final invoice in accordance with Article 5.2(8).~~

25.4.2 Audit Rights Period for All Other Accounts and Records. Accounts and records related to ~~a~~ [either](#) Party's performance or satisfaction of all obligations under this [LGIA Agreement](#) other than those described in Article 25.4.1 shall be subject to audit as follows: (i) for an audit relating to cost obligations, the applicable audit rights period shall be twenty-four months after the auditing Party's receipt of an invoice giving rise to such cost obligations; and (ii) for an audit relating to all other obligations, the applicable audit rights period shall be twenty-four months after the event for which the audit is sought; ~~provided that each Party's rights to audit the CAISO's accounts and records shall be as set forth in Section 22.1 of the CAISO Tariff.~~

25.5 Audit Results. If an audit by ~~the Interconnection Customer or the Participating TO~~ [a Party](#) determines that an overpayment or an underpayment has occurred ~~with respect to the other Party~~, a notice of such overpayment or underpayment shall be given to the other [Party Parties](#) together with those records from the audit which ~~supports~~ [support](#) such determination. ~~The Party that is owed payment shall render an invoice to the other Party and such invoice shall be paid pursuant to Article 12 hereof.~~

~~25.5.1 Notwithstanding anything to the contrary in Article 25.5, the Interconnection Customer's and Participating TO's rights to audit the CAISO's accounts and records shall be as set forth in Section 22.1 of the CAISO Tariff, and the CAISO's process for remedying~~

~~an overpayment or underpayment shall be as set forth in the CAISO Tariff.~~

ARTICLE 26. SUBCONTRACTORS

Article 26. Subcontractors

- 26.1 General.** Nothing in this LGIA Agreement shall prevent a Party from utilizing the services of any subcontractor as it deems appropriate to perform its obligations under this LGIA Agreement; provided, however, that each Party shall require its subcontractors to comply with all applicable terms and conditions of this LGIA Agreement in providing such services and each Party shall remain primarily liable to the other Party for the performance of such subcontractor.
- 26.2 Responsibility of Principal.** The creation of any subcontract relationship shall not relieve the hiring Party of any of its obligations under this LGIA Agreement. The hiring Party shall be fully responsible to the other Parties for the acts or omissions of any subcontractor the hiring Party hires as if no subcontract had been made; provided, however, that in no event shall Transmission Owners or the CAISO ~~or Participating TO~~ be liable for the actions or inactions of ~~the~~ Interconnection Customer or its subcontractors with respect to obligations of ~~the~~ Interconnection Customer under Article 5 of this LGIA Agreement. Any applicable obligation imposed by this LGIA Agreement upon the hiring Party shall be equally binding upon, and shall be construed as having application to, any subcontractor of such Party.
- 26.3 No Limitation by Insurance.** The obligations under this Article 26 will not be limited in any way by any limitation of subcontractor's insurance.

ARTICLE 27. DISPUTES

Article 27. Disputes

~~All disputes~~ Disputes between the Interconnection Customer, CAISO and/or SDG&E arising out of ~~or in connection with this LGIA whereby relief is sought by or from~~ requirements of the CAISO Tariff shall be settled in accordance with the provisions of Article 13 of the CAISO Tariff, except that references to the CAISO Tariff in such Article 13 of the CAISO Tariff shall be read as references to this LGIA Agreement. Disputes between the Interconnection Customer and IID arising out of ~~or in connection with this LGIA not subject to provisions of Article 13 of the CAISO Tariff~~ the Affected System Study Agreement or Affected System Construction and Operation Agreement shall be resolved in accordance with the provisions of Section 13.5 of the Generation Interconnection Procedures in IID's Tariff. All other disputes shall be resolved as follows:

- 27.1 Submission.** In the event ~~either~~ a Party has a dispute, or asserts a claim, that arises out of or in connection with this LGIA Agreement or its performance, such Party (the ~~"disputing Party"~~) shall provide the other Party Parties with written notice of the dispute or claim (~~"Notice of Dispute"~~). Such dispute or claim shall be referred to a designated senior representative of each Party for resolution on an informal basis as promptly as practicable after receipt of the Notice of Dispute by the other Party Parties.

In the event the designated representatives are unable to resolve the claim or dispute through unassisted or assisted negotiations within thirty (30) Calendar Days of the other ~~Party's~~Parties' receipt of the Notice of Dispute, such claim or dispute may, upon mutual agreement of the Parties, be submitted to arbitration and resolved in accordance with the arbitration procedures set forth below. In the event the Parties do not agree to submit such claim or dispute to arbitration, ~~each~~any Party may exercise whatever rights and remedies it may have in equity or at law consistent with the terms of this ~~LGIA~~Agreement.

- 27.2 External Arbitration Procedures.** Any arbitration initiated under this ~~LGIA~~Agreement shall be conducted before a single neutral arbitrator appointed by the Parties. ~~If the Parties fail to agree upon a single arbitrator within ten (10) Calendar Days of the submission of the dispute to arbitration, each Party shall choose one arbitrator who shall sit on a three member arbitration panel. The two arbitrators so chosen shall within twenty (20) Calendar Days select a third arbitrator to chair the arbitration panel. In either case, the arbitrators, or in the absence of such appointment, by selection by the American Arbitration Association. The arbitrator~~ shall be knowledgeable in electric utility matters, including electric transmission and bulk power issues, and shall not have any current or past substantial business or financial relationships with any party to the arbitration (except prior arbitration). The arbitrator~~(s)~~ shall provide each of the Parties an opportunity to be heard and, except as otherwise provided herein, shall conduct the arbitration in accordance with the Commercial Arbitration Rules of the American Arbitration Association ("Arbitration Rules") and any applicable FERC regulations; provided, however, in the event of a conflict between the Arbitration Rules and the terms of this Article 27, the terms of this Article 27 shall prevail.
- 27.3 Arbitration Decisions.** Unless otherwise agreed by the Parties, the arbitrator~~(s)~~ shall render a decision within ninety (90) Calendar Days of appointment and shall notify the Parties in writing of such decision and the reasons therefor. The arbitrator~~(s)~~ shall be authorized only to interpret and apply the provisions of this ~~LGIA~~Agreement and shall have no power to modify or change any provision of this Agreement in any manner. The decision of the arbitrator~~(s)~~ shall be final and binding upon the Parties, and judgment on the award may be entered in any court having jurisdiction. The decision of the arbitrator~~(s)~~ may be appealed solely on the grounds that the conduct of the arbitrator~~(s)~~, or the decision itself, violated the standards set forth in the Federal Arbitration Act or the Administrative Dispute Resolution Act. The final decision of the arbitrator~~(s)~~ must also be filed with FERC if it affects jurisdictional rates, terms and conditions of service, Interconnection Facilities, or Network Upgrades.
- 27.4 Costs.** Each Party shall be responsible for its own costs incurred during the arbitration process and for ~~the following costs, if applicable: (1) its per capita share of the cost of the arbitrator chosen by the Party to sit on the three member panel and one half of the cost of the third arbitrator chosen; or (2) one half the cost of the single arbitrator jointly chosen by the Parties.~~

~~ARTICLE 28. REPRESENTATIONS, WARRANTIES AND COVENANTS~~

Article 28. Representations, Warranties, and Covenants

28.1 General. Each Party makes the following representations, warranties and covenants:

28.1.1 Good Standing. Such Party is duly organized, validly existing and in good standing under the laws of the state in which it is organized, formed, or incorporated, as applicable; that it is qualified to do business in the state or states in which the Large Generating Facility, Interconnection Facilities and Network Upgrades owned by such Party, as applicable, are located; and that it has the corporate power and authority to own its properties, to carry on its business as now being conducted and to enter into this [LGIA Agreement](#) and carry out the transactions contemplated hereby and perform and carry out all covenants and obligations on its part to be performed under and pursuant to this [LGIA Agreement](#).

28.1.2 Authority. Such Party has the right, power and authority to enter into this [LGIA Agreement](#), to become a Party hereto and to perform its obligations hereunder. This [LGIA Agreement](#) is a legal, valid and binding obligation of such Party, enforceable against such Party in accordance with its terms, except as the enforceability thereof may be limited by applicable bankruptcy, insolvency, reorganization or other similar laws affecting creditors' rights generally and by general equitable principles (regardless of whether enforceability is sought in a proceeding in equity or at law).

28.1.3 No Conflict. The execution, delivery and performance of this [LGIA Agreement](#) does not violate or conflict with the organizational or formation documents, or bylaws or operating agreement, of such Party, or any judgment, license, permit, order, material agreement or instrument applicable to or binding upon such Party or any of its assets.

28.1.4 Consent and Approval. Such Party has sought or obtained, or, in accordance with this [LGIA Agreement](#) will seek or obtain, each consent, approval, authorization, order, or acceptance by any Governmental Authority in connection with the execution, delivery and performance of this [LGIA Agreement](#), and it will provide to any Governmental Authority notice of any actions under this [LGIA Agreement](#) that are required by Applicable Laws and Regulations.

ARTICLE 29. [RESERVED]

Article 29. Joint Operating Committee

29.1 Joint Operating Committee. APS, on behalf of the Transmission Owners, shall constitute a Joint Operating Committee to coordinate operating and technical considerations of Interconnection Service. At least six (6) months prior to the expected Initial Synchronization Date, APS and Interconnection Customer shall appoint one representative and one alternate to the Joint Operating Committee. APS and Interconnection Customer shall notify each other of its appointment in writing. Such appointments may be changed at any time by similar notice. The Joint Operating Committee shall meet as necessary, but not less than once each calendar year, to carry out the duties set forth herein. The Joint Operating Committee shall hold a meeting at the

request of any Party, at a time and place agreed upon by the representatives of the Joint Operating Committee. The Joint Operating Committee shall perform all of its duties consistent with the provisions of this Agreement. Each Party shall cooperate in providing to the Joint Operating Committee all information required in the performance of the Joint Operating Committee's duties. All decisions and agreements, if any, made by the Joint Operating Committee, shall be evidenced in writing. The duties of the Joint Operating Committee shall include the following:

29.1.1 Establish data requirements and operating record requirements.

29.1.2 Review the requirements, standards, and procedures for data acquisition equipment, protective equipment, and any other equipment or software.

29.1.3 Annually review the one (1) year forecast of maintenance and planned outage schedules of Transmission Owners' and Interconnection Customer's facilities at the Point of Interconnection.

29.1.4 Coordinate the scheduling of maintenance and planned outages on the Interconnection Facilities, the Large Generating Facility and other facilities that impact the normal operation of the interconnection of the Large Generating Facility to the Transmission System.

29.1.5 Ensure that information is being provided by each Party regarding equipment availability.

29.1.6 Perform such other duties as may be conferred upon it by mutual agreement of the Parties.

ARTICLE 30. MISCELLANEOUS

Article 30. Miscellaneous

- 30.1 Binding Effect.** This LGIA Agreement and the rights and obligations hereof, shall be binding upon and shall inure to the benefit of the successors and assigns of the Parties hereto.
- 30.2 Conflicts.** In the event of a conflict between the body of this LGIA Agreement and any attachment, appendices or exhibits hereto, the terms and provisions of the body of this LGIA Agreement shall prevail and be deemed the final intent of the Parties.
- 30.3 Rules of Interpretation.** This LGIA Agreement, unless a clear contrary intention appears, shall be construed and interpreted as follows: (1) the singular number includes the plural number and vice versa; (2) reference to any person includes such person's successors and assigns but, in the case of a Party, only if such successors and assigns are permitted by this LGIA Agreement, and reference to a person in a particular capacity excludes such person in any other capacity or individually; (3) reference to any agreement (including this LGIA Agreement), document, instrument or tariff means such agreement, document, instrument, or tariff as amended or modified and in effect from time to time in accordance with the terms thereof and, if applicable, the terms hereof; (4) reference to any Applicable Laws and Regulations means such Applicable Laws and

Regulations as amended, modified, codified, or reenacted, in whole or in part, and in effect from time to time, including, if applicable, rules and regulations promulgated thereunder; (5) unless expressly stated otherwise, reference to any Article, Section or Appendix means such Article of this [LGIA Agreement](#) or such Appendix to this [LGIA Agreement](#), or such Section to the [LGIP applicable Large Generator Interconnection Procedures](#) or such Appendix to the [LGIP applicable Large Generator Interconnection Procedures](#), as the case may be; (6) ~~“hereunder”~~, ~~“hereof”~~, ~~“herein”~~, ~~“hereto”~~ and words of similar import shall be deemed references to this [LGIA Agreement](#) as a whole and not to any particular Article or other provision hereof or thereof; (7) ~~“including”~~ (and with correlative meaning ~~“include”~~) means including without limiting the generality of any description preceding such term; and (8) relative to the determination of any period of time, ~~“from”~~ means ~~“from and including”~~, ~~“to”~~ means ~~“to but excluding”~~ and ~~“through”~~ means ~~“through and including”~~.

30.4 Entire Agreement. This [LGIA Agreement](#), including all Appendices and Schedules attached hereto, constitutes the entire agreement among all of the Parties with reference to the subject matter hereof, and supersedes all prior and contemporaneous understandings or agreements, oral or written, ~~between or~~ among the Parties with respect to the subject matter of this [LGIA Agreement](#). There are no other agreements (other than the Affected System Study Agreement and Affected System Construction and Operation Agreement), representations, warranties, or covenants which constitute any part of the consideration for, or any condition to, any Party's compliance with its obligations under this [LGIA Agreement](#).

30.5 No Third Party Beneficiaries. This [LGIA Agreement](#) is not intended to and does not create rights, remedies, or benefits of any character whatsoever in favor of any persons, corporations, associations, or entities other than the Parties, and the obligations herein assumed are solely for the use and benefit of the Parties, their successors in interest and, where permitted, their assigns.

30.6 Waiver. The failure of a Party to this [LGIA Agreement](#) to insist, on any occasion, upon strict performance of any provision of this [LGIA Agreement](#) will not be considered a waiver of any obligation, right, or duty of, or imposed upon, such Party.

Any waiver at any time by either Party of its rights with respect to this [LGIA Agreement](#) shall not be deemed a continuing waiver or a waiver with respect to any other failure to comply with any other obligation, right, duty of this ~~LGIA Agreement~~. Termination or Default of this [LGIA Agreement](#) for any reason by ~~the~~ Interconnection Customer shall not constitute a waiver of ~~the~~ Interconnection Customer's legal rights to obtain an interconnection from ~~the Participating TO~~ [Transmission Owner](#). Any waiver of this [LGIA Agreement](#) shall, if requested, be provided in writing.

30.7 Headings. The descriptive headings of the various Articles of this [LGIA Agreement](#) have been inserted for convenience of reference only and are of no significance in the interpretation or construction of this ~~LGIA Agreement~~.

- 30.8 Multiple Counterparts.** This [LGIA Agreement](#) may be executed in two or more counterparts, each of which is deemed an original but all constitute one and the same instrument.
- 30.9 Amendment.** The Parties may by mutual agreement amend this [LGIA Agreement](#) by a written instrument duly executed by all ~~of~~ the Parties. Such amendment shall become effective and a part of this [LGIA Agreement](#) upon satisfaction of all Applicable Laws and Regulations.
- 30.10 Modification by the Parties.** The Parties may by mutual agreement amend the Appendices to this [LGIA Agreement](#) by a written instrument duly executed by ~~all of~~ the Parties. Such amendment shall become effective and a part of this [LGIA Agreement](#) upon satisfaction of all Applicable Laws and Regulations.
- 30.11 Reservation of Rights.** ~~The CAISO and Participating TO shall each~~ [FERC-jurisdictional Transmission Owners and the CAISO shall](#) have the right to make a unilateral filing with FERC to modify this [LGIA pursuant to Agreement with respect to any rates, terms and conditions, charges, classifications of service, rule or regulation under](#) section 205 or any other applicable provision of the Federal Power Act and FERC's rules and regulations thereunder ~~with respect to the following Articles and Appendices of this LGIA and with respect to any rates, terms and conditions, charges, classifications of service, rule or regulation covered by these Articles and Appendices:~~

~~Recitals, 1, 2.1, 2.2, 2.3, 2.4, 2.6, 3.1, 3.3, 4.1, 4.2, 4.3, 4.4, 5 preamble, 5.4, 5.7, 5.8, 5.9, 5.12, 5.13, 5.18, 5.19.1, 7.1, 7.2, 8, 9.1, 9.2, 9.3, 9.5, 9.6, 9.7, 9.8, 9.10, 10.3, 11.4, 12.1, 13, 14, 15, 16, 17, 18, 19, 20, 21, 22, 23, 24.3, 24.4, 25.1, 25.2, 25.3 (excluding subparts), 25.4.2, 26, 28, 29, 30, Appendix D, Appendix F, Appendix G, and any other Article not reserved exclusively to the Participating TO or the CAISO below.~~

~~The Participating TO shall have the exclusive right to make a unilateral filing with FERC to modify this LGIA pursuant to section 205 or any other applicable provision of the Federal Power Act and FERC's rules and regulations thereunder with respect to the following Articles and Appendices of this LGIA and with respect to any rates, terms and conditions, charges, classifications of service, rule or regulation covered by these Articles and Appendices:~~

~~2.5, 5.1, 5.2, 5.3, 5.5, 5.6, 5.10, 5.11, 5.14, 5.15, 5.16, 5.17, 5.19 (excluding 5.19.1), 6, 7.3, 9.4, 9.9, 10.1, 10.2, 10.4, 10.5, 11.1, 11.2, 11.3, 11.5, 12.2, 12.3, 12.4, 24.1, 24.2, 25.3.1, 25.4.1, 25.5 (excluding 25.5.1), 27 (excluding preamble), Appendix A, Appendix B, Appendix C, and Appendix E.~~

~~The CAISO shall have the exclusive right to make a unilateral filing with FERC to modify this LGIA pursuant to section 205 or any other applicable provision of the Federal Power Act and FERC's rules and regulations thereunder with respect to the following Articles of this LGIA and with respect to any rates, terms and conditions, charges, classifications of service, rule or regulation covered by these Articles:~~

~~3.2, 4.5, 11.6, 25.3.2, 25.5.1, and 27 preamble. The, and~~ Interconnection Customer, ~~the CAISO, and the Participating TO~~ shall have the right to make a unilateral filing with FERC to modify this ~~LGIA Agreement~~ pursuant to section 206 or any other applicable provision of the Federal Power Act and FERC's rules and regulations thereunder; provided that ~~each another~~ Party shall have the right to protest any such filing by ~~another the other~~ Party and to participate fully in any proceeding before FERC in which such modifications may be considered. Nothing in this ~~LGIA Agreement~~ shall limit the rights of the Parties or of FERC under sections 205 or 206 of the Federal Power Act and FERC's rules and regulations thereunder, except to the extent that the Parties otherwise mutually agree as provided herein. Notwithstanding the foregoing, IID shall not be subject, without its mutual consent, to a modification of its rights and obligations under this Agreement through a unilateral filing by another Party with FERC and, as applied to IID, the Effective Date of a modified Agreement shall not commence until the modified Agreement is actually executed by IID, either voluntarily or pursuant to a lawful order issued by FERC in accordance with Sections 210 and 212 of the Federal Power Act.

- 30.12 No Partnership.** This ~~LGIA Agreement~~ shall not be interpreted or construed to create an association, joint venture, agency relationship, or partnership among the Parties or to impose any partnership obligation or partnership liability upon any Party. No Party shall have any right, power or authority to enter into any agreement or undertaking for, or act on behalf of, or to act as or be an agent or representative of, or to otherwise bind, another Party.
- 30.13 Joint and Several Obligations.** Except as otherwise provided in this ~~LGIA Agreement~~, the obligations of ~~each Transmission Owner, the CAISO, the Participating TO,~~ and the Interconnection Customer are several, and are neither joint nor joint and several.

[REMAINDER OF PAGE INTENTIONALLY LEFT BLANK]

_____ **IN WITNESS WHEREOF**, the Parties have executed this LGIA Agreement in multiple originals, each of which shall constitute and be an original effective ~~agreement~~ Agreement among the Parties.

{Insert name of Interconnection Customer}

Arizona Public Service Company _____ Imperial Irrigation District

By: _____ By: _____

Name: _____ Name: _____

Title: _____ Title: _____

Date: _____ Date: _____

{Insert name of Participating TO}

San Diego Gas & Electric Company _____ **California Independent System Operator Corporation**

By: _____ By: _____

Name: _____ Name: _____

Title: _____ Title: _____

Date: _____ Date: _____

Agua Caliente Solar, LLC _____ North Gila River Development, LLC

By: _____ By: _____

Name: _____ Name: _____

Title: _____ Title: _____

Date: _____ Date: _____

Appendices ~~to~~ **LGIA**

~~Appendix A—Interconnection Facilities, Network Upgrades and Distribution Upgrades~~

~~Appendix B—Milestones~~

~~Appendix C—Interconnection Details~~

~~Appendix D—Security Arrangements Details~~

~~Appendix E—Commercial Operation Date~~

~~Appendix F—Addresses for Delivery of Notices and Billings~~

~~Appendix G—Interconnection Customer’s Proportional Share of Costs of Network Upgrades for Applicable Project Group~~

~~Appendix H—Interconnection Requirements for a Wind Generating Plant~~

Appendix A -1 ~~To~~ **LGIA**

Interconnection Facilities, JPP Network Upgrades, and Distribution Upgrades for Phase A of the Interconnection Project

~~1. Interconnection Facilities:~~

~~(a) [insert Interconnection Customer’s Interconnection Facilities]:~~

~~(b) [insert Participating TO’s Interconnection Facilities]:~~

~~2. Network Upgrades:~~

~~(a) [insert Stand Alone Network Upgrades]:~~

~~(b) [insert Other Network Upgrades]:~~

~~(i) [insert Participating TO’s Reliability Network Upgrades]~~

~~(ii) [insert Participating TO’s Delivery Network Upgrades]~~

~~3. Distribution Upgrades:~~

The Generating Facility will have a total rated capacity of 500 MW based on both Phase A and Phase B achieving Commercial Operation. This Appendix A-1 addresses Phase A of the Generating Facility and Appendix A-2 addresses Phase B of the Generating Facility.

1. Phase A of the Generating Facility Description:

Phase A of the Generating Facility is located on private land and consists of a photovoltaic solar field, inverters, a medium voltage collection system, an operations and maintenance building, a 34.5kV/500kV substation and various other facilities. Phase A of the Generating Facility will consist of no more than 290 MW (net) of solar photovoltaic units installed at the site.

The Interconnection Customer Interconnection Facilities include a new substation which will contain two (2) 34.5kV/500kV step-up transformers (“SUTs”). The SUTs are combined through a common high voltage bus that is connected to one single 500 kV interconnection line. Phase A of the Generating Facility is connected to the Transmission Owners’ 500kV switchyard (“Switchyard”) via the single 500kV interconnection line. The substation is located in close proximity to the Switchyard.

2. Point of Interconnection:

The Point of Interconnection for Phase A of the Generating Facility is the Switchyard. See Appendix C – Diagram.

3. Power Injection Limitation at the Point of Interconnection:

The maximum allowable injection of power into the Switchyard at the Point of Interconnection for Phase A of the Generating Facility shall be 290 MW.

4. Point of Change of Ownership:

The Point of Change of Ownership demarcation point of the high voltage conductors and static wires will be the first designed dead end structure outside of the Switchyard fence. The Point of Change of Ownership will be at the line jumper connection point on the Transmission Owners’ dead-ended conductor. Interconnection Customer will provide, per APS specifications, required materials, including foundations, steel structures, insulators, attachment hardware and dead-end connectors to install and terminate conductors at this structure from Switchyard. APS will supply and install conductors to this point of attachment. Interconnection Customer will provide and install materials, including insulators, attachment hardware, conductors, dead-end connectors, and jumper connections, from the Generating Facility substation to the termination point on the dead end structure. See Appendix C – Diagram.

If overhead communication cable is utilized, the interconnection and ownership demarcation point will be a splice point located on the first designed dead-end structure for the high voltage conductor outside of the Switchyard fence. Interconnection Customer will provide required materials for attachment of cable to structures to this point from the Switchyard. APS will provide communication cable to this point. Interconnection Customer will be responsible for providing materials and connection to APS termination at this location.

If underground communication cable is utilized, the interconnection and ownership demarcation point will be a manhole located outside of the Switchyard fence. APS will provide manhole and other

materials required to install cable from the Switchyard. Interconnection Customer will be responsible for providing materials and connection to APS termination at this location.

5. Interconnection Facilities:

(a) Interconnection Customer's Interconnection Facilities

The Interconnection Customer's Interconnection Facilities consists of a 34.5/500kV Generating Facility substation, support structures, including the two sided dead end structure, and a generation tie line from the Generating Facility substation to the Point of Change of Ownership with the Transmission Owner's Interconnection Facilities. The Interconnection Customer's Interconnection Facilities also includes all metering equipment required to comply with the CAISO Tariff.

The following is an equipment list from the Interconnection Customer's Interconnection Facilities:

2 – 34.5kV/500kV step up transformers
Revenue meter
Shunt capacitors
Transmission structure at ownership change

(b) Transmission Owners' Interconnection Facilities

The Transmission Owners' Interconnection Facilities consist of the facilities between the Point of Change of Ownership and Point of Interconnection in the Switchyard. This consists of one 500 kV disconnect switch, and a span of 500kV conductor. The protection equipment for Phase A of the Interconnection Project is also included in Transmission Owners' Interconnection Facilities as is the metering equipment for the interconnection.

The following is an equipment list comprising the Transmission Owners' Interconnection Facilities:

Intertie meter
1 500kV, 3000A, Vertical Break Switch
Conductor
Relays

6. JPP Network Upgrades:

(a) Switchyard

APS will design and construct the new 500kV Switchyard. The Switchyard will be designed as a breaker-and-a-half configuration to accommodate future plans of the Transmission Owners and potential future third-party generation developers. Initially, three 500kV breakers and supporting bus work and structures will be built to accommodate the line terminations from (i) Hassayampa, (ii) North Gila and (iii) the Generating Facility. This initial phase of the Switchyard will include 500kV bus work and disconnect switches to limit outages for future installations.

The Switchyard will also include a control enclosure for the housing of the critical protective relaying and the Supervisory Control and Data Acquisition (SCADA) system. The control room building will include sufficient battery capacity to reliably operate the Switchyard as part of the

interconnected Transmission System. Redundant communication will be provided by a new 100-foot microwave tower constructed to support sufficient dishes and antenna to provide reliable integration of the Generating Facility into the APS communications network. No fiber optic lines are planned for Phase A of the Interconnection Project.

The Switchyard site will be secured with a minimum 7-foot tall, chain link metal-fabric security fence with 1-foot barbed wire or razor wire on top.

The following is an equipment list from the Switchyard portion of the JPP Network Upgrades:

Breakers - 3 500kV, 3000A, 63kA

Switches - 10 500kV, 3000A, Vertical Break

1 500kV 3000A, Vertical Reach

Current Transformers (CTs) - 3 500kV, Extended Range Metering Accuracy 1500/5A

CC Voltage Transformers (11)

A fourth breaker will be required when the Switchyard is converted from a ring bus alignment to a breaker and one half arrangement. The timing for this change will be driven by a fifth termination into the Switchyard.

(b) Transmission Line

The transmission interconnection will be a loop-in of the Switchyard to the existing Hassayampa – North Gila #1 500 kV line with the end points being new turning structures located within the existing 500kV line rights-of-way and the dead-end structures located within the Switchyard.

The following is an equipment/material list from the transmission line portion of the JPP Network Upgrades:

2 500kV Lattice Tower structures

Conductor

7. Stand-Alone JPP Network Upgrades: None

8. Transmission Owners' Interconnection Facilities and JPP Network Upgrade Cost Summary:

Cost Estimate (2010 dollars)

<u>Element</u>	<u>Cost</u>	<u>Transmission Owner Share</u>		
		<u>APS</u>	<u>IID</u>	<u>SDG&E</u>
<u>Transmission Owners' Interconnection Facilities</u>				
<u>500kV conductor tie line</u>	<u>611,000</u>	<u>0</u>	<u>0</u>	<u>0</u>
<u>Disconnect Switches</u>	<u>150,000</u>	<u>0</u>	<u>0</u>	<u>0</u>
<u>Protection Equipment</u>	<u>400,000</u>	<u>0</u>	<u>0</u>	<u>0</u>
<u>Contingency</u>	<u>232,000</u>	<u>0</u>	<u>0</u>	<u>0</u>
<u>1) Subtotal</u>	<u>1,393,000</u>	<u>0</u>	<u>0</u>	<u>0</u>
<u>JPP Network Upgrades</u>				
<u>Transmission</u>	<u>1,985,000</u>	<u>218,350</u>	<u>253,683</u>	<u>1,512,967</u>
<u>Switchyard</u>	<u>14,700,000</u>	<u>1,617,000</u>	<u>1,878,660</u>	<u>11,204,340</u>
<u>Telecommunications</u>	<u>75,000</u>	<u>8,250</u>	<u>9,585</u>	<u>57,165</u>
<u>Relay changes at Hassayampa</u>	<u>136,000</u>	<u>14,960</u>	<u>17,381</u>	<u>103,659</u>
<u>Relay changes at North Gila</u>	<u>136,000</u>	<u>14,960</u>	<u>17,381</u>	<u>103,659</u>
<u>Deferred breaker</u>	<u>810,000</u>	<u>89,100</u>	<u>103,518</u>	<u>617,382</u>
<u>Contingency</u>	<u>3,568,000</u>	<u>392,480</u>	<u>455,990</u>	<u>2,719,530</u>
<u>2) Subtotal JPP Network Upgrades</u>	<u>21,410,000</u>	<u>2,355,100</u>	<u>2,736,198</u>	<u>16,318,702</u>
<u>3) Interconnection Project Cost (for cash flow and financial security) (lines 1 & 2)</u>	<u>22,803,000</u>	<u>2,508,330</u>	<u>2,914,223</u>	<u>17,380,447</u>
<u>4) Interconnection Customer Contributions to Network Upgrades (real estate, environmental, and rough grading)</u>	<u>1,173,000</u>	<u>129,030</u>	<u>149,909</u>	<u>894,060</u>
<u>5) Total Network Upgrades (for reimbursement to Agua Caliente Solar, LLC) (lines 2 & 4)</u>	<u>22,583,000</u>	<u>2,484,130</u>	<u>2,886,107</u>	<u>17,212,763</u>

9. Estimate of Monthly Incurred Costs for the Transmission Owners' Interconnection Facilities and JPP Network Upgrades:

An estimate of the monthly incurred costs is shown below.

<u>Month</u>	<u>Estimated Cost by Month</u>
<u>Through April 2010</u>	<u>\$240,168</u>
<u>May 2010</u>	<u>\$0</u>
<u>June 2010</u>	<u>\$0</u>
<u>July 2010</u>	<u>\$486,924</u>
<u>August 2010</u>	<u>\$0</u>
<u>September 2010</u>	<u>\$0</u>
<u>October 2010</u>	<u>\$863,108</u>
<u>November 2010</u>	<u>\$863,108</u>
<u>December 2010</u>	<u>\$863,108</u>
<u>January 2011</u>	<u>\$5,305,720</u>
<u>February 2011</u>	<u>\$5,305,720</u>
<u>March 2011</u>	<u>\$5,305,720</u>
<u>April 2011</u>	<u>\$337,376</u>
<u>May 2011</u>	<u>\$337,376</u>
<u>June 2011</u>	<u>\$337,376</u>
<u>July 2011</u>	<u>\$348,120</u>
<u>August 2011</u>	<u>\$348,120</u>
<u>September 2011</u>	<u>\$348,120</u>
<u>October 2011</u>	<u>\$119,108</u>
<u>November 2011</u>	<u>\$119,108</u>
<u>December 2011</u>	<u>\$119,108</u>
<u>January 2012</u>	<u>\$1,155,672</u>
<u>Total</u>	<u>\$22,803,000</u>

10. Invoicing and JPP Network Upgrade Repayment:

Invoices issued by APS on behalf of the Transmission Owners pursuant to Articles 12.1 and 12.2 of this Agreement for Phase A of the Generating Facility shall include the cumulative balance invoiced to date for the JPP Network Upgrades (including the actual costs for Network Upgrades incurred under the E&P Agreement) and the allocation of such balance to the Ownership Interests.

Within thirty (30) Calendar Days of the Commercial Operation Date for a Project Phase, APS, on behalf of the Transmission Owners, shall provide the Parties with a statement which indicates the

Ownership Share of each of the Transmission Owners in the cost of the Network Upgrades which are to be repaid in accordance with the provisions of Article 11.4.2 of this Agreement.

(a) SDG&E Share: Interconnection Customer and SDG&E have agreed that SDG&E shall make the repayment provided for in Article 11.4.2 of this Agreement by making a cash payment to Agua Caliente Solar, LLC within sixty (60) Calendar Days of the Commercial Operation Date of each Project Phase.

(b) APS Share: APS shall make the repayment provided for in Article 11.4.1 of this Agreement to Agua Caliente Solar, LLC in accordance with the terms of this Agreement.

(c) IID Share: IID shall make the repayment provided for in Article 11.4.3 of this Agreement to Agua Caliente Solar, LLC in accordance with the terms of this Agreement.

11. Distribution Upgrades: NONE

12. Maintenance, Repair, and Replacement Charges:

The Interconnection Customer shall be responsible for actual costs incurred by APS, on behalf of the Transmission Owners, applicable to the maintenance, repair and replacement of the Transmission Owners' Interconnection Facilities, including but not limited to: the 500 kV disconnect switches, protection equipment for the Interconnection Customer's Interconnection Facilities, metering including CTs and PTs and communications equipment and all associated equipment (see Appendix C, Diagram). A good faith non-binding estimate of annual cost, for budgetary purposes only, is:

Estimate = \$ 1,000 per year

\$1,000 annually covers:

- Two inspections per year
- Relay maintenance (estimated at every 4-6 years)
- Disconnect switch maintenance (estimated at every 4-6 years)

Additional actual costs will be charged for:

- Emergency maintenance and repair work
- Replacement of failed or failing equipment

13. Transition from E&P Agreement:

The Parties recognize that some design and long lead-time procurement work for the interconnection of the Large Generating Facility to the JPP was done pursuant to the E&P Agreement entered into by APS, on behalf of the Transmission Owners, and the Interconnection Customer. In order to provide for a smooth transition between work done under the E&P Agreement and this Agreement, the Parties agree :

(a) Accounting Transition. APS, on behalf of the Transmission Owners, shall calculate whether the Interconnection Customer has paid more or less than it owes under the terms of the E&P Agreement as of the Effective Date of this Agreement. If the Interconnection Customer paid more than it owes, APS, on behalf of the Transmission Owners, shall apply a credit to reduce the amount of the payments required under Article 12.1 of this Agreement for the Transmission Owners' Interconnection Facilities and JPP Network Upgrades. If the Interconnection Customer has paid less than it owes, the Interconnection Customer shall pay the amount due as if it were incurred for engineering and procurement work conducted pursuant to this Agreement, in

accordance with Article 12.1 of this Agreement, for the Transmission Owners' Interconnection Facilities and JPP Network Upgrades.

(b) Estimate of Total Interconnection Customer Payments. In accordance with the Milestone Schedule in Appendix B-1, APS, on behalf of the Transmission Owners, shall provide an estimate of the total amount the Interconnection Customer paid under the E&P Agreement as of the Effective Date of this Agreement. This estimate shall be applied as a credit toward the amount of financial security due from the Interconnection Customer pursuant to Article 11.5 of this Agreement and Section 15 of this Appendix A-1 for the Transmission Owners' Interconnection Facilities and JPP Network Upgrades.

(c) Letter of Credit. If the Interconnection Customer has posted a letter of credit or other financial security under the terms of the E&P Agreement, the letter of credit or other financial security shall be returned to Interconnection Customer as of the date the Interconnection Customer posts all of the financial security required in accordance with the terms of Article 11.5 of this Agreement and Section 14 of this Appendix A-1 for the Transmission Owners' Interconnection Facilities and JPP Network Upgrades.

14. Provision of Security:

(a) Initial Estimate of Financial Security to be Posted: The amount available to be drawn under any credit support for the Transmission Owners' Interconnection Facilities and JPP Network Upgrades required to interconnect Phase A of the Generating Facility shall be:

APS Share (11.00%) \$2,508,330

IID Share (12.78%) \$2,914,223

Subtotal of APS and IID shares (23.78%) \$5,422,553

SDG&E Share (76.22%) \$17,380,447

TOTAL (100%) \$22,803,000

(b) Adjustment for Amounts Paid under E&P Agreement: The initial estimate of the financial security provided in Section 14(a) of this Appendix A-1 shall be reduced by each of the Transmission Owner's proportional shares of the estimated total Interconnection Customer payments made under the E&P Agreement. When APS, on behalf of the Transmission Owners, provides an estimate of the Interconnection Customer's total payments under the E&P Agreement pursuant to Section 13(b) of this Appendix A-1, it shall provide to the Interconnection Customer and the other Transmission Owners an adjusted estimate of the financial security to be posted.

(c) Posting: The Interconnection Customer shall provide financial security for the Transmission Owners' Interconnection Facilities and JPP Network Upgrades no later than the milestone date specified in Appendix B-1 in accordance with Article 11.5 of this Agreement. With respect to the financial security for the APS and IID shares, Interconnection Customer shall post with APS, on behalf of APS and IID, the adjusted amount for both the APS and IID shares provided pursuant to Section 14(b) of this Appendix A-1 in the form of one security instrument.

With respect to the Interconnection Financial Security for SDG&E, SDG&E already holds Interconnection Financial Security for Phase A of the Generating Facility pursuant to the CAISO Tariff. As of the date of signing of this Agreement, this security consists of two irrevocable letters of credit for the benefit of Agua Caliente Solar LLC. One of these letters, in the amount of \$5.8 million, has been posted to cover a portion of the Interconnection Customer's share of Network Upgrades. The other, in the amount of \$228,600 has been posted to cover a portion of the Transmission Owners' Interconnection Facilities. The letter of credit for the larger amount currently posted will terminate in accordance with its terms as of October 30, 2010, and the letter of credit for the smaller amount will terminate in accordance with its terms on October 30, 2010. Pursuant to the terms of the CAISO Tariff, these letters of credit must be replaced before they terminate; failure to do so shall provide grounds for termination of this Agreement as provided in Articles 2.3 and 11.5 of this Agreement.

It is possible that the amount of Interconnection Financial Security which the Interconnection Customer was previously required to post may be reduced by order of FERC as a result of litigation pending in Docket No. EL10-15. Regardless of any developments in that proceeding, Interconnection Customer will post the full amount of financial security as required by this Agreement for Phase A of the Generating Facility.

Under this Agreement the total amount the Interconnection Customer shall post no later than the milestone due date specified in Appendix B-1 shall be the adjusted amount for the SDG&E share provided pursuant to Section 14(b) of this Appendix A-1. If Interconnection Financial Security is to be provided before October 31, 2010, SDG&E agrees that the initial Interconnection Financial Security posted with SDG&E shall be replaced with new Interconnection Financial Security posted in accordance with the terms of this Agreement for the total adjusted amount for the SDG&E share provided pursuant to Section 14(b) of this Appendix A-1. SDG&E further agrees that it shall return the original Interconnection Financial Security and shall take no action to enforce its security rights, if any, under the existing Interconnection Financial Security once Interconnection Customer has posted new Interconnection Financial Security in accordance with the terms of this Agreement.

The Parties agree that the Interconnection Customer shall be allowed to make substitutions of the security posted under this Agreement so long as the new security posted is reasonably acceptable to the Transmission Owners, as provided for in Article 11.5 of this Agreement, and in the amount required by this Agreement.

(d) Reduction of Amount of Security: Interconnection Customer shall make arrangements for financial security that provide for periodic reduction of the amount of the financial security upon receipt of instructions from APS, acting on behalf of the Transmission Owners. APS, on behalf of the Transmission Owners, shall provide periodic notices of reductions in the amount of the financial security required to be held to the financial institution(s) the Interconnection Customer selects to hold the financial security. APS shall provide such notices to the financial institution holding the security for the APS and IID shares in accordance with the arrangements made by the Interconnection Customer with the financial institution(s), provided, however, that the procedures for providing notice are reasonably acceptable to APS. APS shall also provide notice to SDG&E and IID. Unless otherwise agreed by APS and the Interconnection Customer, APS shall provide notice monthly as payments are made in accordance with Article 12.1 and the financial security shall be reduced proportionately on a dollar-for-dollar by the payments made under this Agreement.

SDG&E agrees that within five (5) Calendar Days of receiving notice of a reduction in the amount of the security pursuant to this section, it shall inform the financial institution that holds the Interconnection Financial Security of the reduction in the amount of the security.

(e) **Increases to Security Required Due to Change of Cost Estimates.** In the event that APS, on behalf of the Transmission Owners, finds that the cost estimate for Transmission Owner Interconnection Facilities and JPP Network Upgrades provided in this Appendix A-1 has increased, APS, on behalf of the Transmission Owners, shall have the option of (1) offsetting any reduction in the amount of security under Section 14(d) of this Appendix A-1 with the increase in the cost estimate, or (2) notifying Interconnection Customer of the required increase in its financial security to conform to the increased cost estimate.

(f) **Enforcement of Security for Transmission Owners' Interconnection Facilities and JPP Network Upgrades:** In the event that this Agreement is terminated in accordance with Article 2.3 and APS, on behalf of Transmission Owners, is required to determine the cost responsibility of the Interconnection Customer in accordance with Article 2.4 for Transmission Owners' Interconnection Facilities and JPP Network Upgrades set forth in this Appendix A-1, the Parties agree that in addition to following the procedures set forth elsewhere in this Agreement, the Transmission Owners shall proceed as follows:

(1) Subject to review and approval by all Transmission Owners, APS shall provide a statement indicating the total cost responsibility of the Interconnection Customer to all Transmission Owners and the allocation of this cost responsibility by Ownership Share ("Statement of Cost Responsibility"). This Statement of Cost Responsibility shall be accompanied by a detailed report which shows how the cost responsibility was determined, including information on all expenditures made on behalf of the Interconnection Customer, payments received, and bills outstanding.

(2) If the Interconnection Customer has cost responsibility, upon providing the Statement of Cost Responsibility and accompanying information, APS, on behalf of both APS and IID, shall enforce their financial security rights in proportion to the combined Ownership Interests of APS and IID.

(3) If the Interconnection Customer has cost responsibility, upon receipt of the Statement of Cost Responsibility and accompanying information, SDG&E shall enforce its financial security rights in proportion to the Ownership Interest of SDG&E. Within thirty Calendar Days of receipt of the Statement of Cost Responsibility, SDG&E shall provide the funds it receives by enforcing its financial security rights to APS.

(4) APS, acting on behalf of the Transmission Owners, shall use the funds provided by enforcing the financial security rights of the Transmission Owners to provide reimbursements and settle accounts proportionately in accordance with the Statement of Cost Responsibility and accompanying report.

15. Reporting Requirements:

Until the In-Service Date for the Transmission Owners' Interconnection Facilities and JPP Network Upgrades for Phase A of the Interconnection Project, Interconnection Customer and APS shall conduct a monthly meeting to coordinate the work related to the Transmission Owners' Interconnection Facilities and JPP Network Upgrades in this Appendix A-1. APS shall submit a monthly written report to the Interconnection Customer in advance of the meeting that provides the following information:

- (a) Progress report on activities;
- (b) Project schedule update; and
- (c) Spending report, including actual expenditures to date and forecasted expenditures in accordance with standard accounting practices.

16. Relationship of Agreement to CAISO Phase II Interconnection Study Report

The Parties acknowledge that this Appendix A-1 contains a list of Interconnection Facilities and JPP Network Upgrades and associated cost estimates that differs in some respects from the list of Interconnection Facilities and JPP Network Upgrades and associated cost estimates in the CAISO Phase II Interconnection Study report. The Parties agree to the descriptions of the Interconnection Facilities and JPP Network Upgrades and associated cost estimates in this Agreement notwithstanding any portions of the CAISO Phase II Interconnection Study report that are inconsistent with the terms of this Agreement; provided, however, that any impacts on, and upgrades required to, IID's Affected System (other than the JPP) shall be addressed in the Affected System Study Agreement and Affected System Construction and Operation Agreement to be executed between Interconnection Customer and IID. The Parties also agree that the cost estimates in this Agreement shall serve as the basis for the determination of the amounts of interconnection financial security required pursuant to Article 11.5, including the Interconnection Financial Security required pursuant to Section 9 of the CAISO's LGIP, rather than the cost estimates set forth in the Phase II Interconnection Study report.

Appendix A-2

Interconnection Facilities, JPP Network Upgrades, and Distribution Upgrades for Phase B of the Interconnection Project

The Generating Facility will have a total rated capacity of 500 MW based on both Phase A and Phase B achieving Commercial Operation. Appendix A-1 addresses Phase A of the Generating Facility and this Appendix A-2 addresses Phase B of the Generating Facility. If interconnection studies determined to be necessary pursuant to Section 4 of Appendix C show a need for additional Interconnection Facilities, JPP Network Upgrades, or Distribution Upgrades for Phase B of the Interconnection Project, this Agreement shall be amended in accordance with the provisions of Section 4 of Appendix C.

1. Phase B of the Generating Facility Description:

The Generating Facility consists of a photovoltaic solar field, inverters, a medium voltage collection system, an operations and maintenance building, and various other facilities. Phase B of the Generating Facility will consist of no more than 210 MW (net) of solar photovoltaic units.

The Interconnection Facilities associated with Phase B of the Generating Facility will include additional 34.5kV/500kV transformers and will be connected to the Switchyard via a single 500kV interconnection line separate from the Phase A 500kV interconnection line.

2. Point of Interconnection:

The Point of Interconnection for Phase B of the Generating Facility is the Switchyard. See Appendix C –Diagram.

3. Power Injection Limitation at the Point of Interconnection:

The maximum allowable injection of power into the Switchyard at the Point of Interconnection for Phase B of the Generating Facility shall be 210 MW.

4. Point of Change of Ownership:

The Point of Change of Ownership demarcation point of the high voltage conductors and static wires will be the first designed dead end structure outside of the Switchyard fence. The Point of Change of Ownership will be at the line jumper connection point on the Transmission Owners' dead-ended conductor. Interconnection Customer will provide, per APS specifications, required materials, including foundations, steel structures, insulators, attachment hardware and dead-end connectors to install and terminate conductors at this structure from Switchyard. APS will supply and install conductors to this point of attachment. Interconnection Customer will provide and install materials, including insulators, attachment hardware, conductors, dead-end connectors, and jumper connections, from the Generating Facility substation to the termination point on the dead end structure. See Appendix C – Diagram.

If overhead communication cable is utilized, the interconnection and ownership demarcation point will be a splice point located on the first designed dead-end structure for the high voltage conductor outside of the Switchyard fence. Interconnection Customer will provide required materials for attachment of cable to structures to this point from the Switchyard. APS will provide communication

cable to this point. Interconnection Customer will be responsible for providing materials and connection to APS termination at this location.

If underground communication cable is utilized, the interconnection and ownership demarcation point will be a manhole located outside of the Switchyard fence. APS will provide manhole and other materials required to install cable from the Switchyard. Interconnection Customer will be responsible for providing materials and connection to APS termination at this location.

5. Interconnection Facilities:

(a) Interconnection Customer's Interconnection Facilities.

The Interconnection Customer's Interconnection Facilities consist of additional 34.5/500 kV transformers and a generation tie line from the Generating Facility substation to the Point of Change of Ownership with the Transmission Owner's Interconnection Facilities. The Interconnection Customer's Interconnection Facilities also includes all metering equipment, if any, required for compliance with the CAISO Tariff.

The following is an equipment list from the Interconnection Customer's Interconnection Facilities:

34.5kV/500kV step up transformers
Revenue meter
Shunt capacitors
Transmission structure at ownership change

(b) Transmission Owners' Interconnection Facilities

The Transmission Owners' Interconnection Facilities consist of the facilities between the Point of Change of Ownership and Point of Interconnection in the Switchyard. This consists of one 500 kV disconnect switch, and a span of 500kV conductor. The protection equipment for Phase B of the Interconnection Project is also included in Transmission Owners' Interconnection Facilities as are the metering equipment for the interconnection.

The following is an equipment list from the Transmission Owners' Interconnection Facilities:

Intertie meter
3 500kV, 3000A, Vertical Break Switches
Conductor
Relays

6. JPP Network Upgrades:

APS will design and construct an additional line termination in the new 500kV Switchyard, which will be constructed for Phase A of the Interconnection Project.

The following is an equipment list from the Switchyard portion of the JPP Network Upgrades:

Breakers - 1 500kV, 3000A, 63kA
Switches - 2 500kV, 3000A, Vertical Break

A second breaker will be required when the Switchyard is converted from a ring bus alignment to a breaker and one half arrangement. The timing for this change will be driven by a fifth termination into the Switchyard.

7. Stand-Alone JPP Network Upgrades: None

8. Transmission Owners' Interconnection Facilities and JPP Network Upgrades Cost Summary:

Cost Estimate (2010 dollars)

<u>Element</u>	<u>Cost</u>	<u>Transmission Owner Share</u>		
		<u>APS</u>	<u>IID</u>	<u>SDG&E</u>
<u>Transmission Owners' Interconnection Facilities</u>				
<u>500kV conductor tie line</u>	<u>657,000</u>	<u>0</u>	<u>0</u>	<u>0</u>
<u>Disconnect Switches</u>	<u>150,000</u>	<u>0</u>	<u>0</u>	<u>0</u>
<u>Protection Equipment</u>	<u>375,000</u>	<u>0</u>	<u>0</u>	<u>0</u>
<u>Contingency</u>	<u>236,000</u>	<u>0</u>	<u>0</u>	<u>0</u>
<u>1) Subtotal</u>	<u>1,418,000</u>	<u>0</u>	<u>0</u>	<u>0</u>
<u>JPP Network Upgrades</u>				
<u>Switchyard Breaker</u>	<u>899,000</u>	<u>98,890</u>	<u>114,852</u>	<u>685,218</u>
<u>Deferred breaker</u>	<u>810,000</u>	<u>89,100</u>	<u>103,518</u>	<u>617,382</u>
<u>Contingency</u>	<u>342,000</u>	<u>37,620</u>	<u>43,708</u>	<u>260,672</u>
<u>2) Subtotal</u>	<u>2,051,000</u>	<u>225,610</u>	<u>262,118</u>	<u>1,563,272</u>
<u>3) Total Interconnection Project Cost (for cash flow and financial security) (lines 1 & 2)</u>	<u>3,469,000</u>	<u>381,590</u>	<u>443,338</u>	<u>2,644,072</u>
<u>4) Total Network Upgrades (for reimbursement to North Gila River Development, LLC) (line 2)</u>	<u>2,051,000</u>	<u>225,610</u>	<u>262,118</u>	<u>1,563,272</u>

9. Estimate of Monthly Incurred Costs for the Transmission Owners' Interconnection Facilities and JPP Network Upgrades:

An estimate of the monthly incurred costs is shown below.

<u>Month</u>	<u>Estimated Cost by Month</u>
<u>Oct 2011</u>	<u>26,416</u>
<u>Nov 2011</u>	<u>26,416</u>

<u>Dec 2011</u>	<u>26,416</u>
<u>Jan 2012</u>	<u>609,160</u>
<u>Feb 2012</u>	<u>609,160</u>
<u>Mar 2012</u>	<u>609,160</u>
<u>April 2012</u>	<u>465,980</u>
<u>May 2012</u>	<u>465,980</u>
<u>June 2012</u>	<u>465,980</u>
<u>July 2012</u>	<u>47,180</u>
<u>Aug 2012</u>	<u>47,180</u>
<u>Sept 2012</u>	<u>47,180</u>
<u>Oct 2012</u>	<u>11,396</u>
<u>Nov 2012</u>	<u>11,396</u>
<u>Total</u>	<u>3,469,200</u>

10. Invoicing and JPP Network Upgrade Repayment:

Invoices issued by APS on behalf of the Transmission Owner pursuant to Articles 12.1 and 12.2 of this Agreement for Phase B of the Generating Facility shall include the cumulative balance invoiced to date for the JPP Network Upgrades and the allocation of such balance to the Ownership Interests.

Within thirty (30) Calendar Days of the Commercial Operation Date for a Project Phase, APS, on behalf of the Transmission Owners, shall provide the Parties with a statement which indicates the Ownership Share of each of the Transmission Owners in the cost of the Network Upgrades which are to be repaid in accordance with the provisions of Article 11.4.2 of this Agreement.

- (a) SDG&E Share: Interconnection Customer and SDG&E have agreed that SDG&E shall make the repayment provided for in Article 11.4.2 of this Agreement by making a cash payment to North Gila River Development, LLC within sixty (60) Calendar Days of the Commercial Operation Date of each Project Phase.
- (b) APS Share: APS shall make the repayment provided for in Article 11.4.1 of this Agreement to North Gila River Development, LLC in accordance with the terms of this Agreement.
- (c) IID Share: IID shall make the repayment provided for in Article 11.4.3 of this Agreement to North Gila River Development, LLC in accordance with the terms of this Agreement.

11. Distribution Upgrades: None

12. Maintenance, Repair, and Replacement Charges:

The Interconnection Customer shall be responsible for actual costs incurred by APS, on behalf of the Transmission Owners, applicable to the maintenance, repair and replacement of the Transmission Owners' Interconnection Facilities, including but not limited to: the 500 kV disconnect switches, protection equipment for the Interconnection Customer's Interconnection Facilities, metering including CTs and PTs and communications equipment and all associated equipment (see Appendix C, Diagram). A good faith non-binding estimate of annual cost, for budgetary purposes only, is:

Estimate = \$ 1,000 per year

\$1,000 annually covers:

- Two inspections per year
- Relay maintenance (estimated at every 4-6 years)
- Disconnect switch maintenance (estimated at every 4-6 years)

Additional actual costs will be charged for:

- Emergency maintenance and repair work
- Replacement of failed or failing equipment

13. Provision of Security:

(a) Financial Security to be Posted: The amount available to be drawn under any credit support for the Transmission Owners' Interconnection Facilities and JPP Network Upgrades required to interconnect Phase B of the Generating Facility shall be:

<u>APS Share (11.00%)</u>	<u>\$381,612</u>
<u>IID Share (12.78%)</u>	<u>\$443,364</u>
<u>Subtotal of APS and IID Shares (23.78%)</u>	<u>\$824,976</u>
<u>SDG&E Share (76.22%)</u>	<u>\$2,644,224</u>
<u>TOTAL (100%)</u>	<u>\$3,469,200</u>

(b) Posting: The Interconnection Customer shall provide financial security for the Transmission Owners' Interconnection Facilities and JPP Network Upgrades no later than the milestone due date specified in Appendix B-2 in accordance with Article 11.5 of this Agreement. With respect to the financial security for APS and IID shares, Interconnection Customer shall post with APS, as Operating Agent, the amount for both the APS and IID shares specified in Section 13(a) of this Appendix A-2 in the form of one security instrument.

With respect to the Interconnection Financial Security for SDG&E, the amount posted shall be the amount SDG&E is to provide pursuant to Section 13(a) of this Appendix A-2. The Interconnection Financial Security shall be posted in accordance with the terms of the CAISO tariff.

The Parties agree that the Interconnection Customer shall be allowed to make substitutions of the security posted under this Agreement so long as the new security posted is reasonably acceptable to the Transmission Owners, as provided for in Article 11.5 of this Agreement, and in the amount required by this Agreement.

(c) Reduction of Amount of Security: Interconnection Customer shall make arrangements for financial security that provide for periodic reduction of the amount of the financial security upon receipt of instructions from APS, acting on behalf of the Transmission Owners. APS, on behalf of the Transmission Owners, shall provide periodic notices of reductions in the amount of the financial security required to be held to the financial institution(s) the Interconnection Customer selects to hold the financial security. APS shall provide such

notices to the financial institution holding the security for the APS and IID shares in accordance with the arrangements made by the Interconnection Customer with the financial institution(s), provided, however, that the procedures for providing notice are reasonably acceptable to APS. APS shall also provide notice to SDG&E and IID. Unless otherwise agreed by APS and the Interconnection Customer, APS shall provide notice monthly as payments are made in accordance with Article 12.1 and the financial security shall be reduced proportionately on a dollar-for-dollar by the payments made under this Agreement.

SDG&E agrees that within five (5) Calendar Days of receiving notice of a reduction in the amount of the security pursuant to this section, it shall inform the financial institution that holds the Interconnection Financial Security of the reduction in the amount of the security.

(d) Increases to Security Required Due to Change of Cost Estimates. In the event that APS, on behalf of the Transmission Owners, finds that the cost estimate for Transmission Owner Interconnection Facilities and Network Upgrades provided in this Appendix A-2 has increased, APS, on behalf of the Transmission Owners, shall have the option of (1) offsetting any reduction in the amount of security under Section 13(c) of this Appendix A-2 with the increase in the cost estimate, or (2) notifying Interconnection Customer of the required increase in its financial security to conform to the increased cost estimate.

(e) Enforcement of Security for Transmission Owners' Interconnection Facilities and JPP Network Upgrades: In the event that this Agreement is terminated in accordance with Article 2.3 and APS, on behalf of Transmission Owners, is required to determine the cost responsibility of the Interconnection Customer in accordance with Article 2.4 for Transmission Owners' Interconnection Facilities and JPP Network Upgrades set forth in this Appendix A-2, the Parties agree that in addition to following the procedures set forth elsewhere in the Agreement, the Transmission Owners shall proceed as follows:

- (1)** Subject to review and approval by all Transmission Owners, APS shall provide a statement indicating the total cost responsibility of the Interconnection Customer to all Transmission Owners and the allocation of this cost responsibility by Ownership Share ("Statement of Cost Responsibility"). This Statement of Cost Responsibility shall be accompanied by a detailed report which shows how the cost responsibility was determined, including information on all expenditures made on behalf of the Interconnection Customer, payments received, and bills outstanding.
- (2)** If the Interconnection Customer has cost responsibility, upon providing the Statement of Cost Responsibility and accompanying information, APS, on behalf of both APS and IID, shall enforce their financial security rights in proportion to the combined Ownership Interests of APS and IID.
- (3)** If the Interconnection Customer has cost responsibility, upon receipt of the Statement of Cost Responsibility and accompanying information, SDG&E shall enforce its financial security rights in proportion to the Ownership Interest of SDG&E. Within thirty (30) Calendar Days of receipt of the Statement of Cost Responsibility, SDG&E shall provide the funds it receives by enforcing its financial security rights to APS.
- (4)** APS, acting on behalf of the Transmission Owners, shall use the funds provided by enforcing the financial security rights of the Transmission Owners to provide reimbursements and settle accounts proportionately in accordance with the Statement of Cost Responsibility and accompanying report.

14. Reporting Requirements:

From the date upon which authorization to proceed is provided pursuant to Article 5.1.1 for Phase B of the Generating Facility until the In-Service Date for Phase B of the Interconnection Project, Interconnection Customer and APS shall conduct a monthly meeting to coordinate the work related to the Transmission Owners' Interconnection Facilities and JPP Network Upgrades in this Appendix A-2. APS shall submit a monthly written report to the Interconnection Customer in advance of the meeting that provides the following information:

- (a) Progress report on activities;
- (b) Project schedule update; and
- (c) Spending report, including actual expenditures to date and forecasted expenditures in accordance with standard accounting practices.

Appendix A-3

SDG&E Network Upgrades for Phase B of the Interconnection Project

If the interconnection studies determined to be necessary pursuant to Section 4 of Appendix C identify additional Network Upgrades to be constructed by SDG&E, the Parties shall amend this Agreement to incorporate provisions for those Network Upgrades into this Appendix A-3.

Appendix B To LGIA
Appendix B-1

Milestones

Milestones for Interconnection Facilities and JPP Network Upgrades for Phase A of the Interconnection Project

The Interconnection Customer has selected the Standard Option provided for in Article 5.1. Transmission Owners shall design, procure, and construct Transmission Owner's Interconnection Facilities and JPP Network Upgrades, using Reasonable Efforts to complete Transmission Owner's Interconnection Facilities and JPP Network Upgrades by the dates set forth in this Appendix B-1, Milestones. Milestone dates after October 1, 2010 may be adversely affected by an Effective Date later than October 1, 2010.

<u>Milestones for Interconnection Facilities and JPP Network Upgrades for Phase A of the Interconnection Project</u>	<u>Responsible Party</u>	<u>Due Date</u>
<u>Begin design, permitting and land acquisition for line cut-in facilities</u>	<u>Operating Agent</u>	<u>E&P Agreement</u>
<u>Begin major equipment procurement specifications</u>	<u>Operating Agent</u>	<u>E&P Agreement</u>
<u>Complete planning and equipment specifications</u>	<u>Operating Agent</u>	<u>E&P Agreement</u>
<u>Begin above grade design</u>	<u>Operating Agent</u>	<u>E&P Agreement</u>
<u>Begin below grade design</u>	<u>Operating Agent</u>	<u>E&P Agreement</u>
<u>Submit estimate of Interconnection Customer payments under E&P Agreement and financial security posting requirements</u>	<u>Operating Agent</u>	<u>9/15/2010 or within 5 Calendar Days of Effective Date, if later</u>
<u>Submit interconnection financial security (Sections 5.6.4 and 11.5)</u>	<u>Interconnection Customer</u>	<u>Within 10 Calendar Days of receipt of financial security requirements</u>
<u>Complete transmission line and tower design</u>	<u>Operating Agent</u>	<u>5/31/10</u>
<u>Complete above grade design</u>	<u>Operating Agent</u>	<u>7/30/2010</u>
<u>Additional long lead time material procurement: Breakers, Switches</u>	<u>Operating Agent</u>	<u>Q2 2010</u>
<u>Submit written notice to proceed for procurement of towers</u>	<u>Interconnection Customer</u>	<u>6/1/2010</u>

<u>Complete below grade design</u>	<u>Operating Agent</u>	<u>8/11/10</u>
<u>Submit written authorization to APS to proceed with the construction of the Switchyard portion of Transmission Owners' 500kV Network Upgrades (Section 5.1.1 Standard Option)</u>	<u>Interconnection Customer</u>	<u>10/1/2010 or within 15 Calendar Days of Effective Date, if later</u>
<u>Submit written authorization to APS to proceed with the construction of the transmission line portion of Transmission Owners' 500kV JPP Network Upgrades (section 5.1.1 Standard Option)</u>	<u>Interconnection Customer</u>	<u>11/15/2010 or within 15 Calendar Days of Effective Date, if later</u>
<u>Complete land services/environmental</u>	<u>Operating Agent</u>	<u>12/27/2010</u>
<u>Complete installation of towers and tie line</u>	<u>Operating Agent</u>	<u>3/1/2011</u>
<u>Complete below grade work</u>	<u>Operating Agent</u>	<u>3/1/2011</u>
<u>Complete major equipment procurement</u>	<u>Operating Agent</u>	<u>6/13/2011</u>
<u>Complete material deliveries</u>	<u>Operating Agent</u>	<u>7/11/2011</u>
<u>Complete communications work</u>	<u>Operating Agent</u>	<u>8/22/2011</u>
<u>Complete above grade work</u>	<u>Operating Agent</u>	<u>11/2/2011</u>
<u>Complete control work</u>	<u>Operating Agent</u>	<u>11/3/2011</u>
<u>Line Drop Complete</u>	<u>Operating Agent</u>	<u>11/1/2011</u>
<u>Testing/Commissioning Complete</u>	<u>Operating Agent</u>	<u>12/1/2011</u>
<u>In-Service Date for JPP Network Upgrades and Transmission Owners' Interconnection Facilities</u>	<u>Operating Agent</u>	<u>12/1/2011</u>
<u>In-Service Date for Interconnection Customer's Interconnection Facilities</u>	<u>Interconnection Customer</u>	<u>12/1/2011</u>
<u>Initial Synchronization Date</u>	<u>Interconnection Customer</u>	<u>12/15/2011</u>
<u>Commercial Operation Date (COD) of Phase A of Generating Facility</u>	<u>Interconnection Customer</u>	<u>6/30/2014</u>
<u>Release date of financial security provided for in Appendix A-1 for Phase A of the Interconnection Project</u>	<u>Operating Agent</u>	<u>30 Calendar Days after COD</u>

Early Operations

Given the modular nature of a photovoltaic solar facility, which is constructed in 1-2 MW Project Blocks, various stages of the Generating Facility will be added after Trial Operation of a Project Phase and will commence Commercial Operation prior to the Commercial Operation Date for the Project Phase. From the Initial Synchronization Date for each Project Phase, it is estimated that an additional 8-12 MW will be tested and commence Commercial Operation each month until the entire Project Phase is completed. Following the Initial Synchronization Date, Interconnection Customer will notify APS and CAISO at least ten (10) Calendar Days and not more than thirty (30) Calendar Days prior to the date each portion of the Project Phase with a generation capacity of at least one (1) MW but not more than twenty (20) MW will be completed and commence operation.

Further details regarding early operations will be included in an implementation plan. The proposed implementation plan shall be prepared by the Interconnection Customer and shall be submitted to APS, on behalf of Transmission Owners, and the CAISO for approval at least one-hundred twenty (120) Calendar Days prior to the scheduled In-Service Date for the Transmission Owners' Interconnection Facilities and JPP Network Upgrades for Phase A of the Interconnection Project. CAISO and APS, on behalf of Transmission Owners, shall provide written comments regarding the proposed implementation plan within thirty (30) Calendar Days of receipt. Interconnection Customer, CAISO, and APS shall work in good faith to finalize the implementation plan no later than sixty (60) Calendar Days prior to the scheduled In-Service Date.

Appendix B-2

Milestones for Interconnection Facilities and JPP Network Upgrades for Phase B of the Interconnection Project

The Interconnection Customer has selected the Standard Option provided for in Article 5.1. Transmission Owners shall design, procure, and construct Transmission Owner's Interconnection Facilities and JPP Network Upgrades, using Reasonable Efforts to complete Transmission Owner's Interconnection Facilities and JPP Network Upgrades by the dates set forth in this Appendix B-2, Milestones. Milestone dates after October 1, 2010 may be adversely affected by an Effective Date later than October 1, 2010.

<u>Milestones for Interconnection Facilities and JPP Network Upgrades for Phase B of the Interconnection Project</u>	<u>Responsible Party</u>	<u>Due Date</u>
<u>Submit written notification to Parties of the intended Balancing Authority for Phase B of the Generating Facility</u>	<u>Interconnection Customer</u>	<u>3/15/2011</u>
<u>Complete review of all available studies to determine whether there is a need for additional interconnection studies regarding the possible impacts of Phase B of the Generating Facility on the CAISO Transmission System.</u>	<u>CAISO</u>	<u>4/15/2011</u>
<u>If additional interconnection studies are needed, provide notification to the Parties of the process for having such additional interconnection studies done in accordance with the applicable interconnection process.</u>	<u>CAISO</u>	<u>Note (1)</u>
<u>Complete review of all available studies to determine whether there is a need for additional Affected System Study regarding the possible impacts of Phase B of the Generating Facility on IID's non-JPP facilities.</u>	<u>IID</u>	<u>5/15/ 2011</u>
<u>If additional Affected System Study is needed, provide notification to the Parties of the process for having such additional studies done.</u>	<u>IID</u>	<u>Note (1)</u>
<u>Submit written authorization to proceed with long lead time material procurement and submit procurement financial security</u>	<u>Interconnection Customer</u>	<u>10/1/2011</u>
<u>Begin long lead time material procurement: Breakers, Switches</u>	<u>Operating Agent</u>	<u>1/15/2012</u>
<u>Submit written authorization to APS to proceed with the construction of Phase B of the Interconnection Project and submit construction financial security (Sections 5.6.4 and 11.5)</u>	<u>Interconnection Customer</u>	<u>5/1/2012</u>
<u>In-Service Date for JPP Network Upgrades and Transmission Owners' Interconnection Facilities (conditioned on available outage period)</u>	<u>Operating Agent</u>	<u>10/15/2012</u>

<u>In-Service Date for Interconnection Customer's Interconnection Facilities</u>	<u>Interconnection Customer</u>	<u>10/15/2012</u>
<u>Initial Synchronization Date</u>	<u>Interconnection Customer</u>	<u>11/1/2012</u>
<u>Commercial Operation Date (COD) of Phase B of the Generating Facility</u>	<u>Interconnection Customer</u>	<u>6/15/2015</u>
<u>Release date of financial security provided for in Appendix A-2 for Phase B of the Interconnection Project</u>	<u>Operating Agent</u>	<u>30 Calendar Days after COD</u>

Note 1: If additional studies are required pursuant to Section 4 of Appendix C, the Parties will work together to amend this Agreement to modify this Appendix B-2 to establish a new schedule for Phase B of the Interconnection Project that is reasonably acceptable to all Parties.

Early Operations

Given the modular nature of a photovoltaic solar facility, which is constructed in 1-2 MW Project Blocks, various stages of the Generating Facility will be added after Trial Operation of a Project Phase and will commence Commercial Operation prior to the Commercial Operation Date for the Project Phase. From the Initial Synchronization Date for each Project Phase, it is estimated that an additional 8-12 MW will be tested and commence Commercial Operation each month until the entire Project Phase is completed. Following the Initial Synchronization Date, Interconnection Customer will notify APS and CAISO at least ten (10) Calendar Days and not more than thirty (30) Calendar Days prior to the date each portion of the Project Phase with a generation capacity of at least one (1) MW but not more than twenty (20) MW will be completed and commence operation.

Further details regarding early operations will be included in an implementation plan. The proposed implementation plan shall be prepared by the Interconnection Customer and shall be submitted to APS, on behalf of Transmission Owners, and the CAISO for approval at least one hundred twenty (120) Calendar Days prior to the scheduled In-Service Date for the Transmission Owners' Interconnection Facilities and JPP Network Upgrades for Phase B of the Interconnection Project. CAISO and APS, on behalf of Transmission Owners, shall provide written comments regarding the proposed implementation plan within thirty (30) Calendar Days of receipt. Interconnection Customer, CAISO, and APS shall work in good faith to finalize the implementation plan no later than sixty (60) Calendar Days prior to the scheduled In-Service Date.

Appendix B-3

Milestones for SDG&E Network Upgrades for Phase B of the Interconnection Project

If the interconnection studies determined to be necessary pursuant to Section 4 of Appendix C identify additional Network Upgrades to be constructed by SDG&E, the Parties shall amend this Agreement to incorporate milestones for the construction of those Network Upgrades into this Appendix B-3.

Appendix C
To LGIA

Interconnection Details

1. Description of the Large Generating Facility

The Generating Facility consists of a photovoltaic solar field, inverters, a medium voltage collection system, an operations and maintenance building, a 34.5kV/500kV substation and various other facilities. Phase A of the Generating Facility will consist of no more than 290 MW (net) of solar photovoltaic units installed at the site. Phase B of the Generating Facility will consist of no more than 210 MW (net). The Generating Facility will have with a total rated capacity of 500 MW based on both Phase A and Phase B achieving Commercial Operation.

Phase A of the Generating Facility will be interconnected to the Switchyard via a gen-tie line on the diagram below and Phase B of the Generating Facility will be interconnected to the Switchyard via a separate gen-tie line on the diagram.

2. Diagram Illustrating the Facilities at the Switchyard

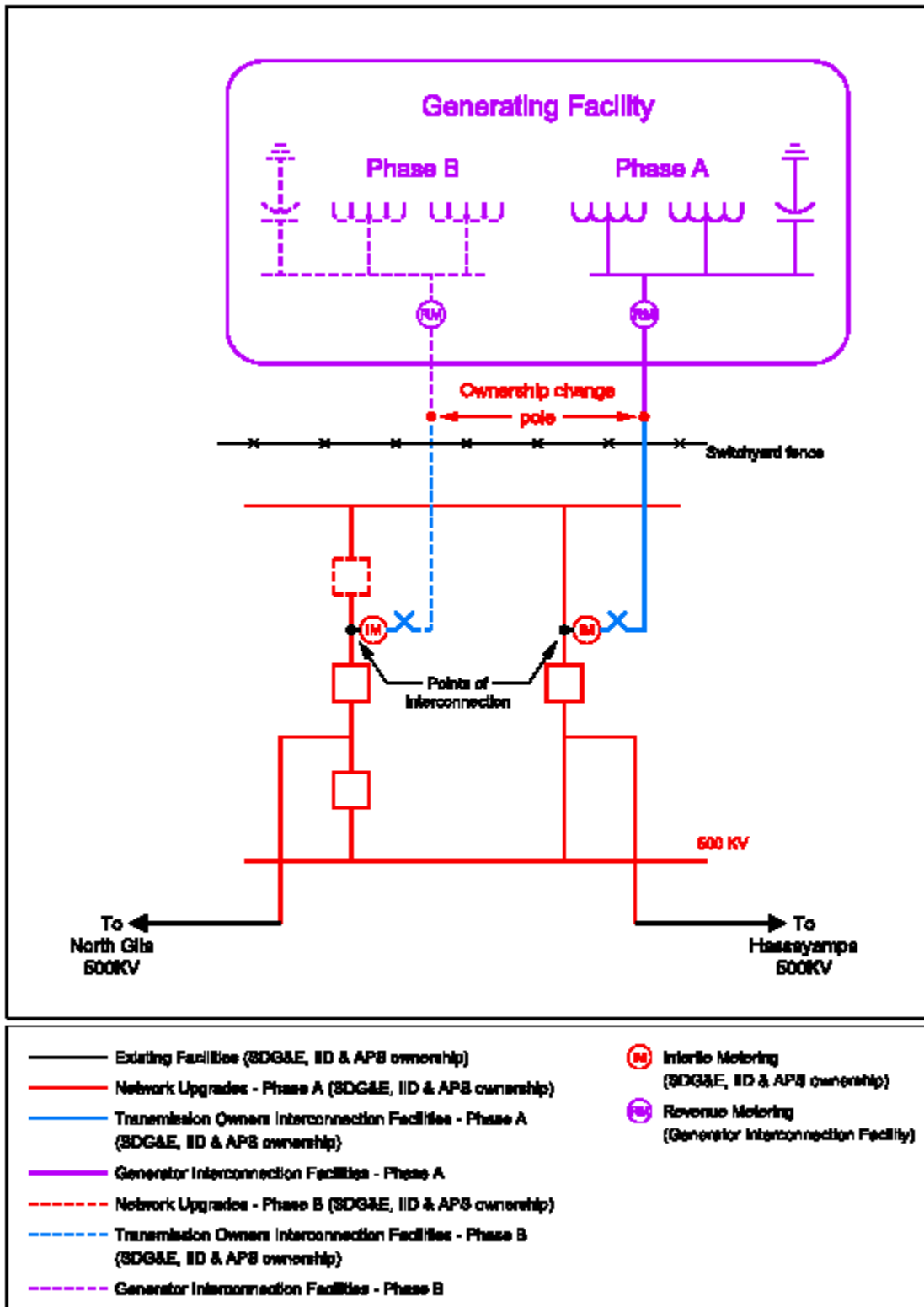

3. Balancing Authority Requirements:

If a Project Phase is to be under a Balancing Authority other than the APS's Balancing Authority, all executed agreements between Interconnection Customer and the other Balancing Authority relating to the Large Generating Facility shall be shared with APS, as the Operating Agent for the JPP.

4. Additional Conditions for Construction of Phase B of the Interconnection Project:

No later than March 15, 2011, Interconnection Customer shall notify the other Parties in writing of the intended Balancing Authority for Phase B of the Generating Facility. Construction of Phase B of the Interconnection Project shall not commence nor shall delivery of energy from Phase B of the Generating Facility to the Transmission System commence until all of the following actions have occurred:

- (a) Interconnection Customer will provide written authorization to APS to proceed with the construction of the Switchyard portion of Transmission Owners' 500kV Network Upgrades for Phase A of the Interconnection Project and Phase A of the Interconnection Project has not otherwise been suspended or terminated.
- (b) Within thirty (30) Calendar Days following receipt of the notice of intended Balancing Authority, the CAISO will review all available studies and determine whether there is a need for additional interconnection studies regarding the possible impacts of Phase B of the Generating Facility on the Transmission System.
- (c) If the CAISO concludes that there is a need for additional interconnection studies, within thirty (30) Calendar Days following receipt of the notice of intended Balancing Authority the CAISO will notify the Parties of the process for having CAISO conduct such additional interconnection studies, which may include the submittal by the Interconnection Customer of an additional Interconnection Request to the CAISO for Phase B of the Generating Facility in accordance with the CAISO's LGIP. Either in accordance with the CAISO's LGIP for a separate Interconnection Request for Phase B of the Generating Facility or pursuant to any other interconnection study process as specified by the CAISO or otherwise determined by FERC for the jurisdictional public utilities which are Parties to this Agreement, the CAISO and Interconnection Customer will enter into an interconnection study agreement under which the Interconnection Customer will agree to pay the reasonable and actual costs of the interconnection studies identified by the CAISO as needed, plus any study deposits required by the CAISO.
- (d) If the CAISO concludes on the basis of the studies provided for in Section 4(c) of this Appendix C that construction of additional facilities is required on the CAISO-controlled grid, this Agreement shall be amended to provide for construction of such facilities and for repayment of the cost of any such facilities that are Network Upgrades in accordance with the principles set forth in Article 11.4.2.
- (e) Within thirty (30) Calendar Days of its receipt of the notice provided by the CAISO in accordance with Section 4(c) of this Appendix C, IID shall determine whether there is a need for an additional Affected System Study regarding the possible impacts of Phase B of the Generating Facility on IID's Transmission System, other than IID's share of the JPP.
- (f) If IID concludes that there is a need for such an additional Affected System Study, IID shall notify the Parties of the process for having IID conduct such an additional Affected System Study and Interconnection Customer shall enter into an Affected System Study Agreement for Phase B of the Generating Facility.
- (g) If IID reasonably concludes on the basis of the studies provided for in Section 4(f) of this Appendix C that construction of additional IID Network Upgrades is required, the

Interconnection Customer and IID shall enter into an Affected System Construction and Operation Agreement for Phase B of the Generating Facility.

5. Joint and Several Liability for Entities Comprising Interconnection Customer

Except as otherwise provided, each entity comprising the Interconnection Customer shall be jointly and severally liable for all obligations required of the Interconnection Customer set forth in this Agreement, including all affirmative covenants and all monetary obligations, the latter of which includes the financing of all Interconnection Facilities and Network Upgrades that are required to be financed by the Interconnection Customer in order to accommodate the interconnection of the entire Generating Facility.

6. Representative of Entities Comprising Interconnection Customer

Agua Caliente Solar LLC and North Gila River Development, LLC shall appoint a single spokesperson, who shall serve as the Interconnection Customer's authorized agent and representative for purposes of administering this Agreement. The designated single spokesperson shall be a single point of contact for CAISO and Transmission Owners and will represent Interconnection Customer for notice purposes and all other communications between and among CAISO, Transmission Owners and Interconnection Customer. Except as otherwise provided, any invoices or refunds due to one of the entities comprising the Interconnection Customer by the Transmission Owners shall be made to the designated single spokesperson. The single spokesperson shall bear all responsibility for disseminating notices, communications and all interactions among the entities comprising the Interconnection Customer, and each entity comprising the Interconnection Customer hereby waives any right to individual notice or communication from CAISO or the Transmission Owners. The CAISO and the Transmission Owners will not be obligated to act on any instructions from either of the entities comprising the Interconnection Customer who is not the designated single spokesperson. The actions of the single spokesperson and his or her representations to CAISO and the Transmission Owners shall be binding upon the Interconnection Customer and each entity comprising the Interconnection Customer. This provision shall be of no further force and effect upon either the division of the Agreement obligations, as set forth in Section 7 of this Appendix C or the termination of Phase B of the Generating Facility, as set forth in Section 8 of this Appendix C.

7. Division of Agreement Obligations.

If the conditions for construction for Phase B of the Interconnection Project set out in Section 4 of this Appendix C have been met, the Interconnection Customer shall determine whether obtaining financing for the Generating Facility on commercially reasonable terms will require separate Large Generator Interconnection Agreements (LGIAs) for Phase A of the Generating Facility and Phase B of the Generating Facility. If the Interconnection Customer determines that separate LGIAs are needed, the Parties agree they shall negotiate in good faith to: (1) amend this Agreement solely for the purpose of making it apply only to Phase A of the Generating Facility and Phase A of the Interconnection Project; and (2) enter into a second LGIA for Phase B of the Generating Facility on terms that are substantially similar in all material relevant respects to this Agreement and to the amended version of this Agreement for Phase A of the Generating Facility. In such event, the joint and several liability set out in Section 5 of this Appendix C shall cease.

8. Termination of Phase B of the Generating Facility.

In addition to the termination right provided in Article 2.3 of this Agreement, and subject to its terms, those of Article 2.4 of the Agreement and any applicable Tariff, North Gila River Development, LLC may terminate this Agreement as it relates to Phase B of the Generating Facility provided the right to

terminate Phase B of the Generating Facility is conditioned on an obligation to fund the Network Upgrades set forth in Appendix A-2 in the event such termination constitutes a Material Modification of the Interconnection Request and is necessary to avoid adversely impacting lower queued interconnection customers. In the event North Gila River Development, LLC elects to terminate this Agreement as it relates to Phase B of the Generating Facility, this Agreement shall be amended accordingly so as to remove all references, terms and conditions pertaining to Phase B of the Generating Facility. Such termination shall leave unaffected the terms and conditions in this Agreement with respect to Phase A of the Generating Facility.

Appendix D To LGIA

Security Arrangements Details

Infrastructure security of ~~CAISO-Controlled Grid~~Transmission System equipment and operations and control hardware and software is essential to ensure day-to-day ~~CAISO-Controlled Grid~~Transmission System reliability and operational security. FERC will expect ~~the CAISO, all Participating TOs~~all transmission providers, market participants, and Interconnection Customers interconnected to the ~~CAISO-Controlled Grid~~Transmission System to comply with the recommendations offered by the President's Critical Infrastructure Protection Board and, eventually, best practice recommendations from the electric reliability authority. All public utilities will be expected to meet basic standards for system infrastructure and operational security, including physical, operational, and cyber-security practices.

~~The~~If the Interconnection Customer selects the CAISO as the Balancing Authority for a Project Phase, for that Project Phase the Interconnection Customer shall meet the requirements for security implemented pursuant to the CAISO Tariff, including the CAISO's standards for information security posted on the CAISO's internet web site at the following internet address: <http://www.caiso.com/pubinfo/info-security/index.html>.

Appendix E
To LGIA

Commercial Operation Date

[This Appendix E ~~sets forth~~ is a ~~form part~~ of ~~letter to be provided by the Interconnection Customer to the CAISO and Participating TO to provide formal notice of the Commercial Operation of an Electric Generating Unit.~~ the Agreement.

[Date]

Arizona Public Service Co.
Attn: Manager of Interconnection Development
MS 2259
P.O. Box 53999
Phoenix, AZ 85072-3999

[CAISO Address]

Mr. Stephen Ruty
Manager of Grid Assets
California Independent System Operator Corporation
151 Blue Ravine Road
Folsom, CA 95630

[Participating TO Address]

Mr. Robert Kott
Manager of Model & Contract Implementation
California Independent System Operator Corporation
151 Blue Ravine Road
Folsom, CA 95630

Re: _____ Electric Commercial Operation Date of Phase ___ of the Generating
Unit Facility

Dear _____:

On [Date] [Interconnection Customer] ~~has~~ completed ~~Trial Operation of Unit No. _____ the~~
last Project Block of Phase ___ of the Generating Facility. This letter confirms that ~~[Interconnection~~
~~Customer] commenced~~ the Commercial Operation Date of Unit No. Phase ___ at of the Electric
Generating Unit, effective as of Facility, is [Date plus one day] and that [Entity Comprising
Interconnection Customer] provided the CAISO's operations personnel advance notice of ~~its~~ this intended
Commercial Operation Date no less than five Business Days prior to that date.

Thank you.

[Signature]
[Interconnection Customer Representative]

Appendix F

To LGIA

Addresses for Delivery of Notices and Billings

Notices:

Operating Agent:

Arizona Public Service Company
Attn: Manager of Interconnection Development
MS 2259
P.O. Box 53999
Phoenix, AZ 85072-3999

Participating TO:

[To be supplied.]

Transmission Owners:

Arizona Public Service Company
Attn: Manager of Interconnection Development
MS 2259
P.O. Box 53999
Phoenix, AZ 85072-3999

Imperial Irrigation District

Attention: Inter-Connect Transmission Contract Administrator
333 East Barioni Boulevard
PO Box 937
Imperial, CA 92251

San Diego Gas & Electric Company

Attn: Transmission Planning Manager
8316 Century Park Court, CP52A
San Diego, CA 92123-1593

California Independent System Operator Corporation

California ISO
Ms. Judy Brown
151 Blue Ravine Rd.
Folsom, CA 95630

Designated Single Spokesperson for Entities Comprising Interconnection Customer:

[To be supplied.]

Agua Caliente Solar, LLC (Phase A) and North Gila River Development, LLC (Phase B)
Attn: : Jim Filippi, Director of Transmission
353 Sacramento St.
Suite 2100
San Francisco, CA 94111

With a copy to:

NextLight Renewable Power, LLC

Attn: Robert F. Miller, Vice President & General Counsel

353 Sacramento St.

Suite 2100

San Francisco, CA 94111

CAISO:

~~_____~~ [To be supplied.]

Billings and Payments:

Participating TO:

~~_____~~ [To be supplied.]

Operating Agent:

Arizona Public Service Company

Attn: Manager of Interconnection Development

MS 2259

P.O. Box 53999

Phoenix, AZ 85072-3999

Interconnection Customer:

~~_____~~ [To be supplied.]

Agua Caliente Solar, LLC (Phase A) and North Gila River Development, LLC (Phase B)

Attn: Controller

353 Sacramento St.

Suite 2100

San Francisco, CA 94111

With a copy to:

NextLight Renewable Power, LLC

Attn: Jim Filippi, Director of Transmission

353 Sacramento St.

Suite 2100

San Francisco, CA 94111

CAISO:

~~_____~~ [To be supplied.]

California Independent System Operator Corporation

California ISO

Finance Dept.

Dennis Estrada

151 Blue Ravine Rd.

Folsom, CA 95630

Alternative Forms of Delivery of Notices (telephone, facsimile or ~~e-mail~~email):

Participating TO:

[To be supplied.]

Interconnection Customer:

[To be supplied.]

CAISO:

[To be supplied.]

Transmission Owners:

Arizona Public Service Company
Attn: Manager, Interconnections Development
MS 2259
P.O. Box 53999
Phoenix, AZ 85072-3999

502 South 2nd Avenue, MS 2259
Phoenix, AZ 85003

Phone: (602) 250-1644
Facsimile: (602) 250-1674
Email: Rex.Stulting@aps.com

Imperial Irrigation District
Attention: Inter-Connect Transmission Contract Administrator
333 East Barioni Boulevard
PO Box 937
Imperial, CA 92251

San Diego Gas & Electric Company
Grid Operations Services Manager
Phone: 619-725-8637
Fax: 619-683-3291

California Independent System Operator Corporation
jbrown@caiso.com

Designated Single Spokesperson for Entities Comprising Interconnection Customer:

Agua Caliente Solar, LLC (Phase A) and North Gila River Development, LLC (Phase B)
Attn: Jim Filippi
353 Sacramento St.
Suite 2100
San Francisco, CA 94111

Phone: (415) 935-2498
Facsimile: (415) 935-2499
Email: jfilippi@nextlight.com

With a copy to:

NextLight Renewable Power, LLC

Attn: Robert F. Miller, Vice President & General Counsel

353 Sacramento St.

Suite 2100

San Francisco, CA 94111

Phone: (415) 935-2500

Facsimile: (415) 935-2501

For Billings:

Agua Caliente Solar, LLC (Phase A) and North Gila River Development, LLC (Phase B)

Attn: Controller

353 Sacramento St.

Suite 2100

San Francisco, CA 94111

Facsimile: (415) 935-2501

Email: ap@nextlight.com

Interconnection Customer Contact Information Regarding General Operating Issues

(Non Real-Time)

Interconnection Customer shall provide Contact information within 120 days of the expected energization of the Switchyard as part of the implementation plan.

Interconnection Customer Contact Information Regarding Real-Time Operating Issues

(Real-Time 24/7)

Interconnection Customer shall provide Contact information within 120 days of the expected energization of the Switchyard as part of the implementation plan.

Operating Agent Contact Information Regarding General Operating Issues

(Non Real-Time)

Arizona Public Service Company

Attn: Thomas Glock, Power Operations Manager

MS 2260

P.O. Box 53999

Phoenix, AZ 85072-3999

502 South 2nd Avenue, MS 2260

Phoenix, AZ 85003

Phone: APS shall provide within 120 days of the expected energization of the
Switchyard

Facsimile: APS shall provide within 120 days of the expected energization of the
Switchyard

Email: Thomas.Glock@aps.com

Operating Agent Contact Information Regarding Real-Time Operating Issues

(Real-Time 24/7)

APS Energy Control Center
ECC Supervisor

Transmission Issues

Phone: APS shall provide within 120 days of the expected energization of the
Switchyard

Generation Issues

Phone: APS shall provide within 120 days of the expected energization of the
Switchyard

Appendix G
To LGIA

Requirements of a Wind Generating Plant

**~~Interconnection Customer's Proportional Share of Costs of Network Upgrades for
Applicable Project Group~~**

Intentionally Omitted as Inapplicable

Appendix H
To LGIA

Reliability Management System Agreement

RELIABILITY MANAGEMENT SYSTEM AGREEMENT

by and between

[TRANSMISSION OPERATOR]

and

[GENERATOR]

THIS RELIABILITY MANAGEMENT SYSTEM AGREEMENT(the "Agreement"), is entered into this _____ day of _____, _____, by and between _____ (the "Transmission Operator") and _____ (the "Generator").

WHEREAS, there is a need to maintain the reliability of the interconnected electric systems encompassed by the WECC in a restructured and competitive electric utility industry;

WHEREAS, with the transition of the electric industry to a more competitive structure, it is desirable to have a uniform set of electric system operating rules within the Western Interconnection, applicable in a fair, comparable and non-discriminatory manner, with which all market participants comply; and

WHEREAS, the members of the WECC, including the Transmission Operator, have determined that a contractual Reliability Management System provides a reasonable, currently available means of maintaining such reliability.

NOW, THEREFORE, in consideration of the mutual agreements contained herein, and other good and valuable consideration, the receipt and sufficiency of which is hereby acknowledged, the Transmission Operator and the Generator agree as follows:

1. PURPOSE OF AGREEMENT

The purpose of this Agreement is to maintain the reliable operation of the Western Interconnection through the Generator's commitment to comply with certain reliability standards.

2. DEFINITIONS

In addition to terms defined in the beginning of this Agreement and in the Recitals hereto, for purposes of this Agreement the following terms shall have the meanings set forth beside them below.

Control Area means an electric system or systems, bounded by interconnection metering and telemetry, capable of controlling generation to maintain its interchange schedule with other Control Areas and contributing to frequency regulation of the Western Interconnection.

FERC means the Federal Energy Regulatory Commission or a successor agency.

Member means any party to the WECC Agreement.

Party means either the Generator or the Transmission Operator and **Parties** means both of the Generator and the Transmission Operator.

Reliability Management System or RMS means the contractual reliability management program implemented through the WECC Reliability Criteria Agreement, the WECC RMS Agreement, this Agreement, and any similar contractual arrangement.

Western Interconnection means the area comprising those states and provinces, or portions thereof, in Western Canada, Northern Mexico and the Western United States in which Members of the WECC operate synchronously connected transmission systems.

Working Day means Monday through Friday except for recognized legal holidays in the state in which any notice is received pursuant to Section 8.

WECC means the Western Electricity Coordinating Council or a successor entity.

WECC Agreement means the Western Electricity Coordinating Council Agreement dated March 20, 1967, as such may be amended from time to time.

WECC Reliability Criteria Agreement means the Western Electricity Coordinating Council Reliability Criteria Agreement dated _____, _____ among the WECC and certain of its member transmission operators, as such may be amended from time to time.

WECC RMS Agreement means an agreement between the WECC and the Transmission Operator requiring the Transmission Operator to comply with the reliability criteria contained in the WECC Reliability Criteria Agreement.

WECC Staff means those employees of the WECC, including personnel hired by the WECC on a contract basis, designated as responsible for the administration of the RMS.

3. TERM AND TERMINATION

3.1 Term. This Agreement shall become effective [thirty (30) days after the date of issuance of a final FERC order accepting this Agreement for filing without requiring any changes to this Agreement unacceptable to either Party. Required changes to this Agreement shall be deemed unacceptable to a Party only if that Party provides notice to the other Party within fifteen (15) days of issuance of the applicable FERC order that such order is unacceptable]. [Note: if the interconnection agreement is not FERC jurisdictional, replace bracketed language with: [on the later of: (a) the date of execution; or (b) the effective date of the WECC RMS Agreement.]

3.2 Notice of Termination of WECC RMS Agreement. The Transmission Operator shall give the Generator notice of any notice of termination of the WECC RMS Agreement by the WECC or by the Transmission Operator within fifteen (15) days of receipt by the WECC or the Transmission Operator of such notice of termination.

3.3 Termination by the Generator. The Generator may terminate this Agreement as follows:

(a) following the termination of the WECC RMS Agreement for any reason by the WECC or by the Transmission Operator, provided such notice is provided within forty-five (45) days of the termination of the WECC RMS Agreement;

(b) following the effective date of an amendment to the requirements of the WECC Reliability Criteria Agreement that adversely affects the Generator, provided notice of such termination is given within forty-five (45) days of the date of issuance of a FERC order accepting such amendment for filing, provided further that the forty-five (45) day period within which notice of termination is required may be extended by the Generator for an additional forty-five (45) days if the Generator gives written notice to the Transmission Operator of such requested extension within the initial forty-five (45) day period; or

(c) on one year's written notice to the Transmission Operator and the WECC, following any change in the WECC Reliability Criteria Agreement that materially affects Generator's obligations.

3.4 Termination by the Transmission Operator. The Transmission Operator may terminate this Agreement on thirty (30) days' written notice following the termination of the WECC RMS Agreement for any reason by the WECC or by the Transmission Operator, provided such notice is provided within thirty (30) days of the termination of the WECC RMS Agreement.

3.5 Mutual Agreement. This Agreement may be terminated at any time by the mutual agreement of the Transmission Operator and the Generator.

4. COMPLIANCE WITH AND AMENDMENT OF WECC RELIABILITY CRITERIA

4.1 Compliance with Reliability Criteria. The Generator agrees to comply with the requirements of the WECC Reliability Criteria Agreement, including the applicable WECC reliability criteria contained in Section IV of Annex A thereof, and, in the event of failure to comply, agrees to be subject to the sanctions applicable to such failure. Each and all of the provisions of the WECC Reliability Criteria Agreement are hereby incorporated by reference into this Agreement as though set forth fully herein, and the Generator shall for all purposes be considered a Participant, and shall be entitled to all of the rights and privileges and be subject to all of the obligations of a Participant, under and in connection with the WECC Reliability Criteria Agreement, including but not limited to the rights, privileges and obligations set forth in Sections 5, 6 and 10 of the WECC Reliability Criteria Agreement.

4.2 Modifications to WECC Reliability Criteria Agreement. The Transmission Operator shall notify the Generator within fifteen (15) days of the receipt of notice from the WECC of the initiation of any WECC process to modify the WECC Reliability Criteria Agreement. The WECC RMS Agreement specifies that such process shall comply with the procedures, rules, and regulations then applicable to the WECC for modifications to reliability criteria.

4.3 Notice of Modifications to WECC Reliability Criteria Agreement. If, following the process specified in Section 4.2, any modification to the WECC Reliability Criteria Agreement is to take effect, the Transmission Operator shall provide notice to the Generator at least forty-five (45) days before such modification is scheduled to take effect.

4.4 Effective Date. Any modification to the WECC Reliability Criteria Agreement shall take effect on the date specified by FERC in an order accepting such modification for filing.

4.5 Transfer of Control or Sale of Generation Facilities. In any sale or transfer of control of any generation facilities subject to this Agreement, the Generator shall as a condition of such sale or transfer require the acquiring party or transferee with respect to the transferred facilities either to assume

the obligations of the Generator with respect to this Agreement or to enter into an agreement with the Control Area Operator in substantially the form of this Agreement.

5. SANCTIONS

5.1 Payment of Monetary Sanctions. The Generator shall be responsible for payment directly to the WECC of any monetary sanction assessed against the Generator pursuant to this Agreement and the WECC Reliability Criteria Agreement. Any such payment shall be made pursuant to the procedures specified in the WECC Reliability Criteria Agreement.

5.2 Publication. The Generator consents to the release by the WECC of information related to the Generator's compliance with this Agreement only in accordance with the WECC Reliability Criteria Agreement.

5.3 Reserved Rights. Nothing in the RMS or the WECC Reliability Criteria Agreement shall affect the right of the Transmission Operator, subject to any necessary regulatory approval, to take such other measures to maintain reliability, including disconnection, which the Transmission Operator may otherwise be entitled to take. Either Party shall have the right to make a unilateral filing with FERC to modify this Agreement with respect to any provision hereof under section 205, section 206, or any other applicable provision of the Federal Power Act and FERC's rules and regulations thereunder; provided that each Party shall have the right to protest any such filing by the other Party and to participate fully in any proceeding before FERC in which such modifications may be considered.

6. THIRD PARTIES

Except for the rights and obligations between the WECC and Generator specified in Sections 4 and 5, this Agreement creates contractual rights and obligations solely between the Parties. Nothing in this Agreement shall create, as between the Parties or with respect to the WECC: (1) any obligation or liability whatsoever (other than as expressly provided in this Agreement), or (2) any duty or standard of care whatsoever. In addition, nothing in this Agreement shall create any duty, liability, or standard of care whatsoever as to any other party. Except for the rights, as a third-party beneficiary with respect to Sections 4 and 5, of the WECC against Generator, no third party shall have any rights whatsoever with respect to enforcement of any provision of this Agreement. Transmission Operator and Generator expressly intend that the WECC is a third-party beneficiary to this Agreement, and the WECC shall have the right to seek to enforce against Generator any provisions of Sections 4 and 5, provided that specific performance shall be the sole remedy available to the WECC pursuant to this Agreement, and Generator shall not be liable to the WECC pursuant to this Agreement for damages of any kind whatsoever (other than the payment of sanctions to the WECC, if so construed), whether direct, compensatory, special, indirect, consequential, or punitive.

7. REGULATORY APPROVALS

This Agreement shall be filed with FERC by the Transmission Operator under Section 205 of the Federal Power Act. In such filing, the Transmission Operator shall request that FERC accept this Agreement for filing without modification to become effective on the day after the date of a FERC order accepting this Agreement for filing.

8. NOTICES

Any notice, demand or request required or authorized by this Agreement to be given in writing to a Party shall be delivered by hand, courier or overnight delivery service, mailed by certified mail (return receipt

requested) postage prepaid, faxed, or delivered by mutually agreed electronic means to such Party at the following address:

Fax: _____

Fax: _____

The designation of such person and/or address may be changed at any time by either Party upon receipt by the other of written notice. Such a notice served by mail shall be effective upon receipt. Notice transmitted by facsimile shall be effective upon receipt if received prior to 5:00 p.m. on a Working Day, and if not received prior to 5:00 p.m. on a Working Day, receipt shall be effective on the next Working Day.

9. APPLICABILITY

This Agreement (including all appendices hereto and, by reference, the WECC Reliability Criteria Agreement) constitutes the entire understanding between the Parties hereto with respect to the subject matter hereof, supersedes any and all previous understandings between the Parties with respect to the subject matter hereof, and binds and inures to the benefit of the Parties and their successors.

10. AMENDMENT

No amendment of all or any part of this Agreement shall be valid unless it is reduced to writing and signed by both Parties hereto. The terms and conditions herein specified shall remain in effect throughout the term and shall not be subject to change through application to the FERC or other governmental body or authority, absent the agreement of the Parties.

11. INTERPRETATION

Interpretation and performance of this Agreement shall be in accordance with, and shall be controlled by, the laws of the State of _____ but without giving effect to the provisions thereof relating to conflicts of law. Article and section headings are for convenience only and shall not affect the interpretation of this Agreement. References to articles, sections and appendices are, unless the context otherwise requires, references to articles, sections and appendices of this Agreement.

12. PROHIBITION ON ASSIGNMENT

This Agreement may not be assigned by either Party without the consent of the other Party, which consent shall not be unreasonably withheld; provided that the Generator may without the consent of the WECC or Transmission Operator assign this Agreement (a) as collateral security to aid in providing financing or refinancing for the construction, ownership or operation of the Generator's power generating facility, or (b) to any acquiring party or transferee referenced in Section 4.5 of this Agreement. If requested by Generator, Transmission Operator will enter into a consent on commercially reasonable terms to any assignment of this Agreement by Generator under this Section 12.

13. SEVERABILITY

If one or more provisions herein shall be invalid, illegal or unenforceable in any respect, it shall be given effect to the extent permitted by applicable law, and such invalidity, illegality or unenforceability shall not affect the validity of the other provisions of this Agreement.

14. COUNTERPARTS

This Agreement may be executed in counterparts and each shall have the same force and effect as an original.

IN WITNESS WHEREOF, the Transmission Operator and the Generator have each caused this Reliability Management System Agreement to be executed by their respective duly authorized officers as of the date first above written.

By: _____
Name: _____
Title: _____

By: _____
Name: _____
Title: _____

~~INTERCONNECTION REQUIREMENTS FOR A WIND GENERATING PLANT~~

~~Appendix H sets forth requirements and provisions specific to a wind generating plant. All other requirements of this LGIA continue to apply to wind generating plant interconnections.~~

~~A. Technical Standards Applicable to a Wind Generating Plant~~

~~i. Low Voltage Ride-Through (LVRT) Capability~~

~~A wind generating plant shall be able to remain online during voltage disturbances up to the time periods and associated voltage levels set forth in the standard below.~~

~~All wind generating plants subject to FERC Order No. 661 must meet the following requirements:~~

- ~~1. Wind generating plants are required to remain in-service during three-phase faults with normal clearing (which is a time period of approximately 4—9 cycles) and single line-to-ground faults with delayed clearing, and subsequent post-fault~~

~~voltage recovery to pre-fault voltage unless clearing the fault effectively disconnects the generator from the system. The clearing time requirement for a three-phase fault will be specific to the wind generating plant substation location, as determined by and documented by the Participating TO. The maximum clearing time the wind generating plant shall be required to withstand for a three-phase fault shall be 9 cycles after which, if the fault remains following the location-specific normal clearing time for three-phase faults, the wind generating plant may disconnect from the CAISO Controlled Grid. A wind generating plant shall remain interconnected during such a fault on the CAISO Controlled Grid for a voltage level as low as zero volts, as measured at the high voltage side of the wind GSU.~~

- ~~2. This requirement does not apply to faults that would occur between the wind generator terminals and the high side of the GSU.~~
- ~~3. Wind generating plants may be tripped after the fault period if this action is intended as part of a special protection system.~~
- ~~4. Wind generating plants may meet the LVRT requirements of this standard by the performance of the generators or by installing additional equipment (e.g., Static VAR Compensator) within the wind generating plant or by a combination of generator performance and additional equipment.~~
- ~~5. Existing individual generator units that are, or have been, interconnected to the CAISO Controlled Grid at the same location at the effective date of the Appendix H LVRT Standard are exempt from meeting the Appendix H LVRT Standard for the remaining life of the existing generation equipment. Existing individual generator units that are replaced are required to meet the Appendix H LVRT Standard.~~

~~ii. Power Factor Design Criteria (Reactive Power)~~

~~A wind generating plant shall operate within a power factor within the range of 0.95 leading to 0.95 lagging, measured at the Point of Interconnection as defined in this LGIA in order to maintain a specified voltage schedule, if the Phase II Interconnection Study shows that such a requirement is necessary to ensure safety or reliability. The power factor range standard can be met by using, for example, power electronics designed to supply this level of reactive capability (taking into account any limitations due to voltage level, real power output, etc.) or fixed and switched capacitors, or a combination of the two, if agreed to by the Participating TO and CAISO. The Interconnection Customer shall not disable power factor equipment while the wind plant is in operation. Wind plants shall also be able to provide sufficient dynamic voltage support in lieu of the power system stabilizer and automatic voltage regulation at the generator excitation system if the Phase II Interconnection Study shows this to be required for system safety or reliability.~~

~~iii. Supervisory Control and Data Acquisition (SCADA) Capability~~

~~The wind plant shall provide SCADA capability to transmit data and receive instructions from the Participating TO and CAISO to protect system reliability. The Participating TO and CAISO and the wind plant Interconnection Customer shall determine what SCADA information is essential for the proposed wind plant, taking into account the size of the plant and its characteristics, location, and importance in maintaining generation resource adequacy and transmission system reliability in its area.~~

ATTACHMENT E

Redline comparison of:

(1) the APS *pro forma* LGIA in Appendix 6 to Attachment O of the APS FERC Electric Tariff, Fourteenth Revised Volume No. 2

to

(2) the CAISO *pro forma* LGIA in Appendix Z of the CAISO FERC Electric Tariff, Fourth Replacement Volume No. II.

Attachment E uses the APS LGIA as the “original” document and the CAISO LGIA as the “new” document. Attachment E is not required to by Commission regulations, but is provided to facilitate the understanding of the differences between the APS LGIA and CAISO LGIA.

For ease of reference, the headers and footers were removed from both the APS LGIA and CAISO LGIA prior to the creation of the redline comparison; therefore, the deletion of the headers and footers is not reflected in the redline comparison.

STANDARD LARGE GENERATOR INTERCONNECTION AGREEMENT (LGIA)
AMONG

[INTERCONNECTION CUSTOMER]
AND

[PARTICIPATING TO]
AND

CALIFORNIA INDEPENDENT SYSTEM OPERATOR CORPORATION

TABLE OF CONTENTS

	Page
RECITALS	314
ARTICLE 1. DEFINITIONS	315 <u>2</u>
ARTICLE 2. EFFECTIVE DATE, TERM, AND TERMINATION	323 <u>10</u>
2.1 Effective Date	<u>323</u> <u>10</u>
2.2 Term of Agreement	<u>323</u> <u>10</u>
2.3 Termination Procedures.....	<u>323</u> <u>10</u>
2.3.1 Written Notice.....	<u>323</u> <u>10</u>
2.3.2 Default.....	<u>323</u> <u>10</u>
<u>2.3.3 Suspension of Work</u>	<u>10</u>
<u>2.3.4</u>	<u>10</u>
2.4 Termination Costs.....	<u>324</u> <u>10</u>
<u>2.4.1</u>	<u>11</u>
<u>2.4.2</u>	<u>12</u>
<u>2.4.3</u>	<u>12</u>
2.5 Disconnection	<u>324</u> <u>12</u>
2.6 Survival	<u>325</u> <u>12</u>
ARTICLE 3. REGULATORY FILINGS <u>AND CAISO TARIFF COMPLIANCE</u>	325 <u>12</u>
3.1 Filing	<u>325</u> <u>12</u>
<u>3.2 Agreement Subject to CAISO Tariff</u>	<u>12</u>
<u>3.3 Relationship Between this LGIA and the CAISO Tariff</u>	<u>13</u>
<u>3.4 Relationship Between this LGIA and the QF PGA</u>	<u>13</u>
ARTICLE 4. SCOPE OF SERVICE	325 <u>13</u>
4.1 Interconnection PRODUCT OPTIONS <u>Service</u>	<u>325</u> <u>13</u>
4.1.1 Energy Resource Interconnection Service	325
4.1.1.1 The Product	325
4.1.1.2 Transmission Delivery Service Implications	325
4.1.2 Network Resource Interconnection Service	326
4.1.2.1 The Product	326
4.1.2.2 Transmission Delivery Service Implications	326
4.2 Provision of Service	<u>328</u> <u>13</u>
4.3 Performance Standards	<u>328</u> <u>13</u>
4.4 No Transmission DELIVERY Service	<u>328</u> <u>14</u>
4.5 Interconnection Customer Provided Services	<u>328</u> <u>14</u>
ARTICLE 5... INTERCONNECTION FACILITIES ENGINEERING, PROCUREMENT, & <u>AND CONSTRUCTION</u>	328 <u>14</u>
5.1 Options	<u>328</u> <u>14</u>
5.1.1 Standard Option.....	<u>328</u> <u>14</u>
5.1.2 Alternate Option	<u>329</u> <u>15</u>

5.1.3	Option to Build.....	329 <u>15</u>
5.1.4	Negotiated Option	329 <u>15</u>
5.2	General Conditions Applicable to Option to Build	330 <u>16</u>
5.3	Liquidated Damages	331 <u>18</u>
5.4	Power System Stabilizers	332 <u>19</u>
5.5	Equipment Procurement	332 <u>19</u>
	<u>5.5.1.....</u>	<u>19</u>
	<u>5.5.2.....</u>	<u>19</u>
	<u>5.5.3.....</u>	<u>19</u>
5.6	Construction Commencement	333 <u>19</u>
	<u>5.6.1.....</u>	<u>20</u>
	<u>5.6.2.....</u>	<u>20</u>
	<u>5.6.3.....</u>	<u>20</u>
	<u>5.6.4.....</u>	<u>20</u>
5.7	Work Progress	333 <u>20</u>
5.8	Information Exchange	333 <u>20</u>
5.9	Limited Operation	333 <u>20</u>
5.10	Interconnection Customer's Interconnection Facilities (ICIF)	334 <u>21</u>
	5.10.1 <u>Large Generating Facility and</u> Interconnection Customer's	
	Interconnection Facility <u>Facilities</u> Specifications	334 <u>21</u>
	5.10.2 Transmission Provider <u>Participating TO's and CAISO's</u> Review	334 <u>21</u>
	5.10.3 ICIF Construction <u>Interconnection Customer's Interconnection</u>	
	<u>Facilities Construction</u>	334 <u>21</u>
	<u>5.10.4 Interconnection Customer to Meet Requirements of the</u>	
	<u>Participating TO's Interconnection Handbook.....</u>	<u>22</u>
5.11	TRANSMISSION PROVIDER <u>Participating TO's</u> Interconnection Facilities	
	Construction.....	334 <u>22</u>
5.12	Access Rights	335 <u>22</u>
5.13	Lands of Other Property Owners	335 <u>23</u>
5.14	Permits.....	335 <u>23</u>
5.15	Early Construction of Base Case Facilities	335 <u>23</u>
5.16	Suspension	336 <u>23</u>
5.17	Taxes	336 <u>24</u>
	5.17.1 Interconnection Customer Payments Not Taxable	336 <u>24</u>
	5.17.2 Representations and Covenants	336 <u>24</u>
	5.17.3 Indemnification for the Cost Consequences of Current Tax	
	Liability Imposed Upon the Transmission Provider <u>Participating TO</u>	337 <u>25</u>
	5.17.4 Tax Gross-Up Amount	338 <u>26</u>
	5.17.5 Private Letter Ruling or Change or Clarification of Law.....	338 <u>27</u>
	5.17.6 Subsequent Taxable Events	339 <u>27</u>
	5.17.7 Contests.....	339 <u>27</u>
	5.17.8 Refund.....	340 <u>28</u>
	5.17.9 Taxes Other Than Income Taxes	341 <u>29</u>
	5.17.10 Transmission Owners Who Are Not Transmission Providers	341
5.18	Tax Status	341 <u>30</u>
5.19	Modification.....	341 <u>30</u>
	5.19.1 General	341 <u>30</u>

5.19.2 Standards.....	34231
5.19.3 Modification Costs.....	34231
ARTICLE 6. TESTING AND INSPECTION.....	34231
6.1 Pre-Commercial Operation Date Testing and Modifications	34231
6.2 Post-Commercial Operation Date Testing and Modifications.....	34331
6.3 Right to Observe Testing	34332
6.4 Right to Inspect.....	34332
ARTICLE 7. METERING	34332
7.1 General	34332
7.2 Check Meters.....	34333
7.3 STANDARDS <u>Participating TO Retail Metering</u>	34433
7.4 TESTING OF METERING EQUIPMENT.....	344
7.5 METERING DATA.....	344
ARTICLE 8. COMMUNICATIONS	34533
8.1 Interconnection Customer Obligations.....	34533
8.2 Remote Terminal Unit.....	34533
8.3 No Annexation	34534
ARTICLE 9. OPERATIONS	34634
9.1 General.....	34634
9.2 CONTROL <u>Balancing Authority</u> Area Notification.....	34634
9.3 TRANSMISSION PROVIDER <u>CAISO and Participating TO</u> Obligations.....	34634
9.4 Interconnection Customer Obligations	34635
9.5 Start-Up and Synchronization	34635
9.6 Reactive Power.....	34735
9.6.1 Power Factor Design Criteria	34735
9.6.2 Voltage Schedules	34735
9.6.2.1 Governors and Regulators.....	34736
9.6.3 Payment for Reactive Power.....	34837
9.7 Outages and Interruptions	34837
9.7.1 Outages	34837
9.7.1.1 Outage Authority and Coordination.....	34837
9.7.1.2 Outage Schedules	34837
9.7.1.3 Outage Restoration.....	34938
9.7.2 Interruption of Service	34938
<u>9.7.2.1.....</u>	<u>38</u>
<u>9.7.2.2.....</u>	<u>38</u>
<u>9.7.2.3.....</u>	<u>38</u>
<u>9.7.2.4.....</u>	<u>39</u>
<u>9.7.2.5.....</u>	<u>39</u>
9.7.3 Under-Frequency and Over -Frequency Conditions.....	35039
9.7.4 System Protection and Other Control Requirements	35039
9.7.4.1 System Protection Facilities.....	35039
<u>9.7.4.2.....</u>	<u>40</u>

9.7.4.3	40
9.7.4.4	40
9.7.4.5	40
9.7.4.6	40
9.7.5 Requirements for Protection	351 40
9.7.6 Power Quality	351 41
9.8 Switching and Tagging Rules	351 41
9.9 Use of Interconnection Facilities by Third Parties	351 41
9.9.1 Purpose of Interconnection Facilities	352 41
9.9.2 Third Party Users	352 42
9.10 Disturbance Analysis Data Exchange	352 42
ARTICLE 10. MAINTENANCE	352 42
10.1 TRANSMISSION PROVIDER <u>Participating TO</u> Obligations	352 42
10.2 Interconnection Customer Obligations	352 42
10.3 Coordination	352 42
10.4 Secondary Systems	353 42
10.5 Operating and Maintenance Expenses	353 43
ARTICLE 11. PERFORMANCE OBLIGATION	353 43
11.1 Interconnection Customer's Interconnection Facilities	353 43
11.2 TRANSMISSION PROVIDER <u>Participating TO's</u> Interconnection Facilities	353 43
11.3 Network Upgrades and Distribution Upgrades	353 43
11.4 Transmission Credits	353 43
11.4.1 Repayment of Amounts Advanced for Network Upgrades	353 44
11.4.2 <u>Special Provisions for Affected Systems</u>	44
11.4.3	45
11.5 Provision of Security	355 45
11.5.1	45
11.5.2	45
11.5.3	45
11.6 Interconnection Customer Compensation	355 45
11.6.1 Interconnection Customer Compensation for Actions During Emergency Condition	356 45
ARTICLE 12. INVOICE	356 46
12.1 General	356 46
12.2 Final Invoice	356 46
12.3 Payment	356 46
12.4 Disputes	356 47
ARTICLE 13. EMERGENCIES	357 47
13.1 DEFINITION <u>[Reserved]</u>	357 47
13.2 Obligations	357 47
13.3 Notice	357 47
13.4 Immediate Action	357 48

13.5	TRANSMISSION PROVIDER <u>CAISO and Participating TO</u> Authority.....	357 <u>48</u>
13.5.1	General	358 <u>48</u>
13.5.2	Reduction and Disconnection.....	358 <u>49</u>
13.6	Interconnection Customer Authority.....	358 <u>49</u>
13.7	Limited Liability	359 <u>49</u>
ARTICLE 14. REGULATORY REQUIREMENTS AND GOVERNING LAW		359 <u>49</u>
14.1	Regulatory Requirements	359 <u>49</u>
14.2	Governing Law.....	359 <u>50</u>
	<u>14.2.1.....</u>	<u>50</u>
	<u>14.2.2.....</u>	<u>50</u>
	<u>14.2.3.....</u>	<u>50</u>
ARTICLE 15. NOTICES.....		360 <u>50</u>
15.1	General.....	360 <u>50</u>
15.2	Billings and Payments.....	360 <u>50</u>
15.3	Alternative Forms of Notice.....	360 <u>50</u>
15.4	Operations and Maintenance Notice.....	360 <u>50</u>
ARTICLE 16. FORCE MAJEURE.....		360 <u>51</u>
<u>16.1</u>	<u>Force Majeure</u>	<u>51</u>
	<u>16.1.1.....</u>	<u>51</u>
	<u>16.1.2.....</u>	<u>51</u>
ARTICLE 17. DEFAULT		361 <u>51</u>
17.1	Default	361 <u>51</u>
17.1.1	General	361 <u>51</u>
17.1.2	Right to Terminate.....	361 <u>51</u>
ARTICLE 18. INDEMNITY, CONSEQUENTIAL DAMAGES, AND INSURANCE		361 <u>52</u>
18.1	Indemnity	361 <u>52</u>
18.1.1	Indemnified Person <u>Party</u>	361 <u>52</u>
18.1.2	Indemnifying Party.....	362 <u>52</u>
18.1.3	Indemnity Procedures	362 <u>52</u>
18.2	Consequential Damages.....	362 <u>53</u>
18.3	Insurance.....	363 <u>53</u>
	<u>18.3.1.....</u>	<u>53</u>
	<u>18.3.2.....</u>	<u>53</u>
	<u>18.3.3.....</u>	<u>54</u>
	<u>18.3.4.....</u>	<u>54</u>
	<u>18.3.5.....</u>	<u>54</u>
	<u>18.3.6.....</u>	<u>54</u>
	<u>18.3.7.....</u>	<u>54</u>
	<u>18.3.8.....</u>	<u>55</u>
	<u>18.3.9.....</u>	<u>55</u>
	<u>18.3.10.....</u>	<u>55</u>

<u>18.3.11</u>	<u>55</u>
ARTICLE 19. ASSIGNMENT	364 <u>55</u>
<u>19.1 Assignment</u>	<u>55</u>
ARTICLE 20. SEVERABILITY	365 <u>56</u>
<u>20.1 Severability</u>	<u>56</u>
ARTICLE 21. COMPARABILITY	366 <u>56</u>
<u>21.1 Comparability</u>	<u>56</u>
ARTICLE 22. CONFIDENTIALITY	366 <u>56</u>
22.1 Confidentiality	366 <u>56</u>
22.1.1 Term	366 <u>57</u>
22.1.2 Scope	366 <u>57</u>
22.1.3 Release of Confidential Information	367 <u>57</u>
22.1.4 Rights	367 <u>58</u>
22.1.5 No Warranties	367 <u>58</u>
22.1.6 Standard of Care	367 <u>58</u>
22.1.7 Order of Disclosure	367 <u>58</u>
22.1.8 Termination of Agreement	367 <u>58</u>
22.1.9 Remedies	368 <u>58</u>
22.1.10 Disclosure to FERC, its Staff, or a State	368 <u>59</u>
<u>22.1.11</u>	<u>59</u>
ARTICLE 23. ENVIRONMENTAL RELEASES	369 <u>60</u>
<u>23.1</u>	<u>60</u>
ARTICLE 24. INFORMATION REQUIREMENTS	369 <u>60</u>
24.1 Information Acquisition.....	369 <u>60</u>
24.2 Information Submission by TRANSMISSION PROVIDER <u>Participating TO</u> ..	369 <u>60</u>
24.3 Updated Information Submission by Interconnection Customer	369 <u>60</u>
24.4 Information Supplementation	370 <u>61</u>
ARTICLE 25. INFORMATION ACCESS AND AUDIT RIGHTS	371 <u>62</u>
25.1 Information Access	371 <u>62</u>
25.2 Reporting of Non-Force Majeure Events.....	371 <u>62</u>
25.3 Audit Rights	371 <u>62</u>
<u>25.3.1</u>	<u>62</u>
<u>25.3.2</u>	<u>63</u>
25.4 Audit Rights Periods	371 <u>63</u>
25.4.1 Audit Rights Period for Construction-Related Accounts and Records	371 <u>63</u>
25.4.2 Audit Rights Period for All Other Accounts and Records	372 <u>63</u>
25.5 Audit Results.....	372 <u>63</u>

<u>25.5.1</u>	64
ARTICLE 26. SUBCONTRACTORS	37264
26.1 General	37264
26.2 Responsibility of Principal	37264
26.3 No Limitation by Insurance	37264
ARTICLE 27. DISPUTES	37264
27.1 Submission	37264
27.2 External Arbitration Procedures	37365
27.3 Arbitration Decisions	37365
27.4 Costs.....	37365
ARTICLE 28. REPRESENTATIONS, WARRANTIES, AND COVENANTS	37366
28.1 General	37366
28.1.1 Good Standing	37366
28.1.2 Authority	37466
28.1.3 No Conflict.....	37466
28.1.4 Consent and Approval.....	37466
ARTICLE 29. JOINT OPERATING COMMITTEE <u>RESERVED</u>	37566
ARTICLE 30. MISCELLANEOUS	37567
30.1 Binding Effect.....	37567
30.2 Conflicts	37667
30.3 Rules of Interpretation.....	37667
30.4 Entire Agreement	37667
30.5 No Third Party Beneficiaries	37667
30.6 Waiver.....	37668
30.7 Headings.....	37768
30.8 Multiple Counterparts.....	37768
30.9 Amendment	37768
30.10 Modification by the Parties.....	37768
30.11 Reservation of Rights.....	37768
30.12 No Partnership.....	37769
<u>30.13 Joint and Several Obligations</u>	<u>69</u>

Appendix A - Interconnection Facilities, Network Upgrades, and Distribution Upgrades

Appendix B - Milestones

Appendix C - Interconnection Details

Appendix D - Security Arrangements Details

Appendix E - Commercial Operation Date

Appendix F - Addresses for Delivery of Notices and Billings

Appendix G - Interconnection Customer's Proportional Share of Costs of Network Upgrades for Applicable Project Group

Appendix H - Interconnection Requirements ~~of~~ for a Wind Generating Plant

~~Appendix H - Reliability Management System Agreement~~

STANDARD
LARGE GENERATOR INTERCONNECTION AGREEMENT

[INTERCONNECTION CUSTOMER]

[PARTICIPATING TO]

CALIFORNIA INDEPENDENT SYSTEM OPERATOR CORPORATION

THIS ~~STANDARD~~ LARGE GENERATOR INTERCONNECTION AGREEMENT (~~"Agreement"~~"LGIA") is made and entered into this ____ day of _____ 20____, by and ~~between~~ among _____, a _____ organized and existing under the laws of the State/Commonwealth of _____ ("**Interconnection Customer**" with a Large Generating Facility), ~~and~~ _____, a _____ corporation organized and existing under the laws of the State/~~Commonwealth of~~ _____ ("~~Transmission Provider and/or Transmission Owner~~" of California ("**Participating TO**"), and California Independent System Operator Corporation, a California nonprofit public benefit corporation organized and existing under the laws of the State of California ("CAISO"). Interconnection Customer, Participating TO, and ~~Transmission Provider~~ CAISO each may be referred to as a "Party" or collectively as the "Parties."

RECITALS

Recitals

WHEREAS, CAISO exercises Operational Control over the CAISO Controlled Grid; and

WHEREAS, ~~Transmission Provider~~ the Participating TO owns, operates, and maintains the Participating TO's Transmission System; and

WHEREAS, Interconnection Customer intends to own, lease and/or control and operate the Generating Facility identified as a Large Generating Facility in Appendix C to this ~~Agreement~~ LGIA; and;

WHEREAS, Interconnection Customer, Participating TO, and ~~Transmission Provider~~ CAISO have agreed to enter into this ~~Agreement~~ LGIA for the purpose of interconnecting the Large Generating Facility with the Participating TO's Transmission System;

NOW, THEREFORE, in consideration of and subject to the mutual covenants contained herein, it is agreed:

When used in this ~~Standard Large Generator Interconnection Agreement~~ LGIA, terms with initial capitalization that are not defined in Article 1 shall have the meanings specified in the Article in which they are used ~~or the Open Access Transmission Tariff (Tariff).~~

~~Article 1. — Definitions~~

ARTICLE 1. DEFINITIONS

Adverse System Impact shall mean the negative effects due to technical or operational limits on conductors or equipment being exceeded that may compromise the safety and reliability of the electric system.

Affected System shall mean an electric system other than the ~~Transmission Provider's Transmission System~~ CAISO Controlled Grid that may be affected by the proposed interconnection, including the Participating TO's electric system that is not part of the CAISO Controlled Grid.

~~— **Affected System Operator** shall mean the entity that operates an Affected System.~~

Affiliate shall mean, with respect to a corporation, partnership or other entity, each such other corporation, partnership or other entity that directly or indirectly, through one or more intermediaries, controls, is controlled by, or is under common control with, such corporation, partnership or other entity.

~~— **Ancillary Services** shall mean those services that are necessary to support the transmission of capacity and energy from resources to loads while maintaining reliable operation of the Transmission Provider's Transmission System in accordance with Good Utility Practice.~~

Applicable Laws and Regulations shall mean all duly promulgated applicable federal, state and local laws, regulations, rules, ordinances, codes, decrees, judgments, directives, or judicial or administrative orders, permits and other duly authorized actions of any Governmental Authority.

Applicable Reliability Council shall mean the ~~reliability council applicable to the Transmission System to which the Generating Facility is directly interconnected.~~ Western Electricity Coordinating Council or its successor.

Applicable Reliability Standards shall mean the requirements and guidelines of NERC, the Applicable Reliability Council, and the ~~Control~~ Balancing Authority Area of the Participating TO's Transmission System to which the Generating Facility is directly ~~interconnected~~ connected, including requirements adopted pursuant to Section 215 of the Federal Power Act.

Balancing Authority shall mean the responsible entity that integrates resource plans ahead of time, maintains load-interchange-generation balance within a Balancing Authority Area, and supports Interconnection frequency in real time.

Balancing Authority Area shall mean the collection of generation, transmission, and loads within the metered boundaries of the Balancing Authority. The Balancing Authority maintains load-resource balance within this area.

Base Case shall mean the base case power flow, short circuit, and stability data bases used for the Interconnection Studies ~~by the Transmission Provider or Interconnection Customer.~~

Breach shall mean the failure of a Party to perform or observe any material term or condition of ~~the Standard Large Generator Interconnection Agreement~~ this LGIA.

Breaching Party shall mean a Party that is in Breach of ~~the Standard Large Generator Interconnection Agreement~~ this LGIA.

Business Day shall mean Monday through Friday, excluding ~~Federal Holidays~~ federal holidays and the day after Thanksgiving Day.

CAISO Controlled Grid shall mean the system of transmission lines and associated facilities of the parties to the Transmission Control Agreement that have been placed under the CAISO's Operational Control.

CAISO Tariff shall mean the CAISO's tariff, as filed with FERC, and as amended or supplemented from time to time, or any successor tariff.

Calendar Day shall mean any day including Saturday, Sunday or a ~~Federal Holiday~~ federal holiday.

~~Clustering shall mean the process whereby a group of Interconnection Requests is studied together, instead of serially, for the purpose of conducting the Interconnection System Impact Study.~~

Commercial Operation shall mean the status of an Electric Generating Unit or project phase at a Generating Facility that has commenced generating electricity for sale, excluding electricity generated during Trial Operation.

Commercial Operation Date of ~~a unit~~ an Electric Generating Unit or project phase shall mean the date on which the Electric Generating Unit or project phase at the Generating Facility commences Commercial Operation as agreed to by the ~~Parties~~ applicable Participating TO, the CAISO, and the Interconnection Customer pursuant to Appendix E to ~~the Standard Large Generator Interconnection Agreement~~ this LGIA, and in accordance with the implementation plan agreed to by the Participating TO and the CAISO for multiple individual Electric Generating Units or project phases at a Generating Facility where an Interconnection Customer intends to establish separate Commercial Operation Dates for those Electric Generating Units or project phases.

Confidential Information shall mean any confidential, proprietary or trade secret information of a plan, specification, pattern, procedure, design, device, list, concept, policy or compilation relating to the present or planned business of a Party, which is

designated as confidential by the Party supplying the information, whether conveyed orally, electronically, in writing, through inspection, or otherwise, subject to Article 22.1.2.

~~Control Area shall mean an electrical system or systems bounded by interconnection metering and telemetry, capable of controlling generation to maintain its interchange schedule with other Control Areas and contributing to frequency regulation of the interconnection. A Control Area must be certified by the Applicable Reliability Council.~~

Default shall mean the failure of a Breaching Party to cure its Breach in accordance with Article 17 of ~~the Standard Large Generator Interconnection Agreement~~ this LGIA.

~~Dispute Resolution shall mean the procedure for resolution of a dispute between the Parties in which they will first attempt to resolve the dispute on an informal basis.~~

Distribution System shall mean ~~the Transmission Provider's facilities and equipment used to transmit electricity to ultimate usage points such as homes and industries directly from nearby generators or from interchanges with higher voltage transmission networks which transport bulk power over longer distances. The voltage levels at which distribution systems operate differ among areas~~ those non-CAISO-controlled transmission and distribution facilities owned by the Participating TO.

Distribution Upgrades shall mean the additions, modifications, and upgrades to the ~~Transmission Provider's Distribution System at or beyond the Point of Interconnection to facilitate interconnection of the Generating Facility and render the transmission service necessary to effect Interconnection Customer's wholesale sale of electricity in interstate commerce~~ Participating TO's Distribution System. Distribution Upgrades do not include Interconnection Facilities.

Effective Date shall mean the date on which ~~the Standard Large Generator Interconnection Agreement~~ this LGIA becomes effective upon execution by ~~the~~ all Parties subject to acceptance by FERC, or if filed unexecuted, upon the date specified by FERC.

Electric Generating Unit shall mean an individual electric generator and its associated plant and apparatus whose electrical output is capable of being separately identified and metered.

Emergency Condition shall mean a condition or situation: (1) that in the judgment of the Party making the claim is imminently likely to endanger life or property; or (2) that, in the case of ~~a Transmission Provider~~ the CAISO, is imminently likely (as determined in a non-discriminatory manner) to cause a material adverse effect on the security of, or damage to, the CAISO Controlled Grid or the electric systems of others to which the CAISO Controlled Grid is directly connected; (3) that, in the case of the Participating TO, is imminently likely (as determined in a non-discriminatory manner) to cause a material adverse effect on the security of, or damage to ~~Transmission Provider's Transmission System, Transmission Provider's Interconnection Facilities or the electric systems of others to which the Transmission Provider's Transmission System is directly connected;~~ or (3) that, in the case of ~~Interconnection Customer,~~ is imminently likely (as determined in a non-discriminatory manner) to cause a

~~material adverse effect on the security of, or damage to, the~~, the Participating TO's Transmission System, Participating TO's Interconnection Facilities, Distribution System, or the electric systems of others to which the Participating TO's electric system is directly connected; or (4) that, in the case of the Interconnection Customer, is imminently likely (as determined in a non-discriminatory manner) to cause a material adverse effect on the security of, or damage to, the Generating Facility or Interconnection Customer's Interconnection Facilities. System restoration and black start shall be considered Emergency Conditions; provided, that Interconnection Customer is not obligated by ~~the Standard Large Generator Interconnection Agreement~~this LGIA to possess black start capability.

~~Energy Resource Interconnection Service shall mean an Interconnection Service that allows the Interconnection Customer to connect its Generating Facility to the Transmission Provider's Transmission System to be eligible to deliver the Generating Facility's electric output using the existing firm or nonfirm capacity of the Transmission Provider's Transmission System on an as available basis. Energy Resource Interconnection Service in and of itself does not convey transmission service.~~

~~Engineering & Procurement (E&P) Agreement shall mean an agreement that authorizes the Transmission Provider to begin engineering and procurement of long lead time items necessary for the establishment of the interconnection in order to advance the implementation of the Interconnection Request.~~

Environmental Law shall mean Applicable Laws or Regulations relating to pollution or protection of the environment or natural resources.

Federal Power Act shall mean the Federal Power Act, as amended, 16 U.S.C. §§ 791a et seq.

FERC shall mean the Federal Energy Regulatory Commission ~~(Commission)~~ or its successor.

Force Majeure shall mean any act of God, labor disturbance, act of the public enemy, war, insurrection, riot, fire, storm or flood, explosion, breakage or accident to machinery or equipment, any order, regulation or restriction imposed by governmental, military or lawfully established civilian authorities, or any other cause beyond a Party's control. A Force Majeure event does not include acts of negligence or intentional wrongdoing by the Party claiming Force Majeure.

Generating Facility shall mean the Interconnection Customer's ~~device~~Electric Generating Unit(s) used for the production of electricity identified in the Interconnection Customer's Interconnection Request, but shall not include the Interconnection Customer's Interconnection Facilities.

Generating Facility Capacity shall mean the net capacity of the Generating Facility and the aggregate net capacity of the Generating Facility where it includes multiple energy production devices.

Good Utility Practice shall mean any of the practices, methods and acts engaged in or approved by a significant portion of the electric utility industry during the relevant time period, or any of the practices, methods and acts which, in the exercise of reasonable judgment in light of the facts known at the time the decision was made, could have been expected to accomplish the desired result at a reasonable cost consistent with good business practices, reliability, safety and expedition. Good Utility Practice is not intended to be ~~limited to~~ any one of a number of the optimum ~~practice, method~~ practices, methods, or ~~act~~ acts to the exclusion of all others, but rather to be acceptable practices, methods, or acts generally accepted in the region.

Governmental Authority shall mean any federal, state, local or other governmental, regulatory or administrative agency, court, commission, department, board, or other governmental subdivision, legislature, rulemaking board, tribunal, or other governmental authority having jurisdiction over the Parties, their respective facilities, or the respective services they provide, and exercising or entitled to exercise any administrative, executive, police, or taxing authority or power; provided, however, that such term does not include the Interconnection Customer, ~~Transmission Provider~~ CAISO, Participating TO, or any Affiliate thereof.

Hazardous Substances shall mean any chemicals, materials or substances defined as or included in the definition of “hazardous substances,” “hazardous wastes,” “hazardous materials,” “hazardous constituents,” “restricted hazardous materials,” “extremely hazardous substances,” “toxic substances,” “radioactive substances,” “contaminants,” “pollutants,” “toxic pollutants” or words of similar meaning and regulatory effect under any applicable Environmental Law, or any other chemical, material or substance, exposure to which is prohibited, limited or regulated by any applicable Environmental Law.

Initial Synchronization Date shall mean the date upon which ~~the~~ an Electric Generating ~~Facility~~ Unit is initially synchronized and upon which Trial Operation begins.

In-Service Date shall mean the date upon which the Interconnection Customer reasonably expects it will be ready to begin use of the ~~Transmission Provider~~ Participating TO's Interconnection Facilities to obtain back feed power.

~~Interconnection Customer shall mean any entity, including the Transmission Provider, Transmission Owner or any of the Affiliates or subsidiaries of either, that proposes to interconnect its Generating Facility with the Transmission Provider's Transmission System.~~

Interconnection Customer's Interconnection Facilities shall mean all facilities and equipment, as identified in Appendix A of ~~the Standard Large Generator Interconnection Agreement~~ this LGIA, that are located between the Generating Facility and the Point of Change of Ownership, including any modification, addition, or upgrades to such facilities and equipment necessary to physically and electrically interconnect the Generating Facility to the ~~Transmission Provider~~ Participating TO's Transmission System. Interconnection Customer's Interconnection Facilities are sole use facilities.

Interconnection Facilities shall mean the ~~Transmission Provider~~ Participating TO's Interconnection Facilities and the Interconnection Customer's Interconnection Facilities. Collectively, Interconnection Facilities include all facilities and equipment between the Generating Facility and the Point of Interconnection, including any modification, additions or upgrades that are necessary to physically and electrically interconnect the Generating Facility to the ~~Transmission Provider~~ Participating TO's Transmission System. Interconnection Facilities are sole use facilities and shall not include Distribution Upgrades, Stand Alone Network Upgrades or Network Upgrades.

~~Interconnection Facilities Study shall mean a study conducted by the Transmission Provider or a third party consultant for the Interconnection Customer to determine a list of facilities (including Transmission Provider's Interconnection Facilities and Network Upgrades as identified in the Interconnection System Impact Study), the cost of those facilities, and the time required to interconnect the Generating Facility with the Transmission Provider's Transmission System. The scope of the study is defined in Section 8 of the Standard Large Generator Interconnection Procedures.~~

~~Interconnection Facilities Study Agreement shall mean the form of agreement contained in Appendix 4 of the Standard Large Generator Interconnection Procedures for conducting the Interconnection Facilities Study.~~

~~Interconnection Feasibility Study shall mean a preliminary evaluation of the system impact and cost of interconnecting the Generating Facility to the Transmission Provider's Transmission System, the scope of which is described in Section 6 of the Standard Large Generator Interconnection Procedures.~~

Interconnection Financial Security shall have the meaning assigned to it in Section 1.2 of the LGIP.

~~Interconnection Feasibility Study Agreement shall mean the form of agreement contained in Appendix 2 of the Standard Large Generator Interconnection Procedures for conducting the Interconnection Feasibility Study.~~

Interconnection Handbook shall mean a handbook, developed by the Participating TO and posted on the Participating TO's web site or otherwise made available by the Participating TO, describing technical and operational requirements for wholesale generators and loads connected to the Participating TO's portion of the CAISO Controlled Grid, as such handbook may be modified or superseded from time to time. Participating TO's standards contained in the Interconnection Handbook shall be deemed consistent with Good Utility Practice and Applicable Reliability Standards. In the event of a conflict between the terms of this LGIA and the terms of the Participating TO's Interconnection Handbook, the terms in this LGIA shall apply.

Interconnection Request shall mean ~~an Interconnection Customer's~~ a request, in the form of Appendix 1 to the ~~Standard~~ Large Generator Interconnection Procedures, in accordance with the CAISO Tariff, ~~to interconnect a new Generating Facility, or to increase the capacity of, or make a Material Modification to the operating characteristics of, an existing Generating Facility that is interconnected with the Transmission Provider's Transmission System.~~

Interconnection Service shall mean the service provided by the ~~Transmission Provider~~ Participating TO and CAISO associated with interconnecting the Interconnection Customer's Generating Facility to the ~~Transmission Provider~~ Participating TO's Transmission System and enabling ~~it~~ the CAISO Controlled Grid to receive electric energy and capacity from the Generating Facility at the Point of Interconnection, pursuant to the terms of ~~the Standard Large Generator Interconnection Agreement and, if applicable, the Transmission Provider's~~ this LGIA, the Participating TO's Transmission Owner Tariff, and the CAISO Tariff.

Interconnection Study shall mean ~~any~~ either of the following studies: the ~~Interconnection Feasibility Study, the Interconnection System Impact Study, and the Interconnection Facilities Study described in the Standard~~ Phase I Interconnection Study or the Phase II Interconnection Study conducted or caused to be performed by the CAISO, in coordination with the applicable Participating TO(s), pursuant to the Large Generator Interconnection Procedures.

~~—————**Interconnection System Impact Study** shall mean an engineering study that evaluates the impact of the proposed interconnection on the safety and reliability of Transmission Provider's Transmission System and, if applicable, an Affected System. The study shall identify and detail the system impacts that would result if the Generating Facility were interconnected without project modifications or system modifications, focusing on the Adverse System Impacts identified in the Interconnection Feasibility Study, or to study potential impacts, including but not limited to those identified in the Scoping Meeting as described in the Standard Large Generator Interconnection Procedures.~~

~~—————**Interconnection System Impact Study Agreement** shall mean the form of agreement contained in Appendix 3 of the Standard Large Generator Interconnection Procedures for conducting the Interconnection System Impact Study.~~

IRS shall mean the Internal Revenue Service.

~~—————**Joint Operating Committee** shall be a group made up of representatives from Interconnection Customers and the Transmission Provider to coordinate operating and technical considerations of Interconnection Service.~~

Large Generating Facility shall mean a Generating Facility having a Generating Facility Capacity of more than 20 MW.

Large Generator Interconnection Procedures (LGIP) shall mean the CAISO protocol that sets forth the interconnection procedures applicable to an Interconnection Request pertaining to a Large Generating Facility that is included in CAISO Tariff Appendix Y.

Large Generator Interconnection Study Process Agreement shall mean the agreement between the Interconnection Customer and the CAISO for the conduct of the Interconnection Studies.

Loss shall mean any and all damages, losses relating to injury to or death of any person or damage to property, and claims, including claims and actions relating to injury to or death of any person or damage to property, demand, suits, recoveries, costs and expenses, court costs, attorney fees, and all other obligations by or to third parties, arising out of or resulting from the other Party's performance, or non-performance of its obligations under the Standard Large Generator Interconnection Agreement on behalf of the indemnifying Party, except in cases of gross negligence or intentional wrongdoing by the indemnifying Party.

Material Modification shall mean those modifications that have a material impact on the cost or timing of any Interconnection Request or any other valid interconnection request with a later queue priority date.

Metering Equipment shall mean all metering equipment installed or to be installed at for measuring the output of the Generating Facility pursuant to ~~the Standard Large Generator Interconnection Agreement~~ this LGIA at the metering points, including but not limited to instrument transformers, MWh-meters, data acquisition equipment, transducers, remote terminal unit, communications equipment, phone lines, and fiber optics.

NERC shall mean the North American Electric Reliability Council or its successor organization.

~~Network Resource shall mean any designated generating resource owned, purchased, or leased by a Network Customer under the Network Integration Transmission Service Tariff. Network Resources do not include any resource, or any portion thereof, that is committed for sale to third parties or otherwise cannot be called upon to meet the Network Customer's Network Load on a non-interruptible basis.~~

Network Upgrades shall be Participating TO's Delivery Network Upgrades and Participating TO's Reliability Network Upgrades.

~~Network Resource Interconnection Service shall mean an Interconnection Service that allows the Interconnection Customer to integrate its Large Generating Facility with the Transmission Provider's Transmission System (1) in a manner comparable to that in which the Transmission Provider integrates its generating facilities to serve native load customers; or (2) in an RTO or ISO with market based congestion management, in the same manner as Network Resources. Network Resource Interconnection Service in and of itself does not convey transmission service.~~

Operational Control shall mean the rights of the CAISO under the Transmission Control Agreement and the CAISO Tariff to direct the parties to the Transmission Control Agreement how to operate their transmission lines and facilities and other electric plant affecting the reliability of those lines and facilities for the purpose of affording comparable non-discriminatory transmission access and meeting applicable reliability criteria.

Participating TO's Delivery Network Upgrades shall mean the additions, modifications, and upgrades to the Participating TO's Transmission ~~Provider's Transmission System~~ required at or beyond the point at which the Interconnection Facilities connect to the Transmission Provider's Transmission System to accommodate the interconnection of the Large

~~Generating Facility to the Transmission Provider's Transmission System~~ at or beyond the Point of Interconnection, other than Reliability Network Upgrades, identified in the Interconnection Studies, as identified in Appendix A, to relieve constraints on the CAISO Controlled Grid.

~~Notice of Dispute shall mean a written notice of a dispute or claim that arises out of or in connection with the Standard Large Generator Interconnection Agreement or its performance.~~

Participating TO's Interconnection Facilities shall mean all facilities and equipment owned, controlled or operated by the Participating TO from the Point of Change of Ownership to the Point of Interconnection as identified in Appendix A to this LGIA, including any modifications, additions or upgrades to such facilities and equipment. Participating TO's Interconnection Facilities are sole use facilities and shall not include Distribution Upgrades, Stand Alone Network Upgrades or Network Upgrades.

~~Optional Interconnection Study shall mean a sensitivity analysis based on assumptions specified by the Interconnection Customer in the Optional Interconnection Study Agreement.~~

Participating TO's Reliability Network Upgrades shall mean the additions, modifications, and upgrades to the Participating TO's Transmission System at or beyond the Point of Interconnection, identified in the Interconnection Studies, as identified in Appendix A, necessary to interconnect the Large Generating Facility safely and reliably to the Participating TO's Transmission System, which would not have been necessary but for the interconnection of the Large Generating Facility, including additions, modifications, and upgrades necessary to remedy short circuit or stability problems resulting from the interconnection of the Large Generating Facility to the Participating TO's Transmission System. Participating TO's Reliability Network Upgrades also include, consistent with Applicable Reliability Standards and Applicable Reliability Council practice, the Participating TO's facilities necessary to mitigate any adverse impact the Large Generating Facility's interconnection may have on a path's Applicable Reliability Council rating. Participating TO's Reliability Network Upgrades do not include any Participating TO's Delivery Network Upgrades.

~~Optional Interconnection Study Agreement shall mean the form of agreement contained in Appendix 5 of the Standard Large Generator Interconnection Procedures for conducting the Optional Interconnection Study.~~

Participating TO's Transmission System shall mean the facilities owned and operated by the Participating TO and that have been placed under the CAISO's Operational Control, which facilities form part of the CAISO Controlled Grid.

Party or Parties shall mean ~~Transmission Provider, Transmission Owner~~ the Participating TO, CAISO, Interconnection Customer or any the applicable combination of the above.

Phase I Interconnection Study shall mean the engineering study conducted or caused to be performed by the CAISO, in coordination with the applicable Participating TO(s), that evaluates the impact of the proposed interconnection on the safety and reliability of the Participating TO's Transmission System and, if applicable, an Affected System. The study shall identify and detail the system impacts that would result if the Generating Facility(ies) were interconnected without identified project modifications or system modifications, as provided in the On-Peak Deliverability Assessment (as defined in the CAISO Tariff), and other potential impacts, including but not limited to those identified in the Scoping Meeting as described in the Large Generator Interconnection Procedures. The study will also identify the approximate total costs, based on per unit costs, of mitigating these impacts, along with an equitable allocation of those costs to Interconnection Customers for their individual Generating Facilities.

Phase II Interconnection Study shall mean an engineering and operational study conducted or caused to be performed by the CAISO once per calendar year, in coordination with the applicable Participating TO(s), to determine the Point of Interconnection and a list of facilities (including the Participating TO's Interconnection Facilities, Network Upgrades, Distribution Upgrades, and Stand Alone Network Upgrades), the cost of those facilities, and the time required to interconnect the Generating Facility(ies) with the Participating TO's Transmission System.

Point of Change of Ownership shall mean the point, as set forth in Appendix A to ~~the Standard Large Generator Interconnection Agreement~~this LGIA, where the Interconnection Customer's Interconnection Facilities connect to the ~~Transmission Provider~~Participating TO's Interconnection Facilities.

Point of Interconnection shall mean the point, as set forth in Appendix A to ~~the Standard Large Generator Interconnection Agreement~~this LGIA, where the Interconnection Facilities connect to the ~~Transmission Provider~~Participating TO's Transmission System.

QF PGA shall mean a Qualifying Facility Participating Generator Agreement specifying the special provisions for the operating relationship between a Qualifying Facility and the CAISO, a pro forma version of which is set forth in Appendix B.3 of the CAISO Tariff.

~~———— **Queue Position** shall mean the order of a valid Interconnection Request, relative to all other pending valid Interconnection Requests, that is established based upon the date and time of receipt of the valid Interconnection Request by the Transmission Provider.~~

Qualifying Facility shall mean a qualifying cogeneration facility or qualifying small power production facility, as defined in the Code of Federal Regulations, Title 18, Part 292 (18 C.F.R. §292).

Reasonable Efforts shall mean, with respect to an action required to be attempted or taken by a Party under ~~the Standard Large Generator Interconnection Agreement~~this LGIA, efforts that are timely and consistent with Good Utility Practice and are otherwise substantially equivalent to those a Party would use to protect its own interests.

Scoping Meeting shall mean the meeting ~~between~~among representatives of the Interconnection Customer ~~and Transmission Provider,~~ the Participating TO(s), other Affected Systems, and the CAISO conducted for the purpose of discussing alternative interconnection options, to exchange information including any transmission data and earlier study evaluations that would be reasonably expected to impact such interconnection options, to analyze such information, and to determine the potential feasible Points of Interconnection.

~~Site Control shall mean documentation reasonably demonstrating: (1) ownership of, a leasehold interest in, or a right to develop a site for the purpose of constructing the Generating Facility; (2) an option to purchase or acquire a leasehold site for such purpose; or (3) an exclusivity or other business relationship between Interconnection Customer and the entity having the right to sell, lease or grant Interconnection Customer the right to possess or occupy a site for such purpose.~~

~~Small Generating Facility shall mean a Generating Facility that has a Generating Facility Capacity of no more than 20 MW.~~

Stand Alone Network Upgrades shall mean Network Upgrades that ~~an~~the Interconnection Customer may construct without affecting day-to-day operations of the ~~Transmission System~~CAISO Controlled Grid or Affected Systems during their construction. ~~Both the Transmission Provider~~The Participating TO, the CAISO, and the Interconnection Customer must agree as to what constitutes Stand Alone Network Upgrades and identify them in Appendix A to ~~the Standard Large Generator Interconnection Agreement.~~ this LGIA.

~~Standard Large Generator Interconnection Agreement (LGIA) shall mean the form of interconnection agreement applicable to an Interconnection Request pertaining to a Large Generating Facility that is included in the Transmission Provider's Tariff.~~

~~Standard Large Generator Interconnection Procedures (LGIP) shall mean the interconnection procedures applicable to an Interconnection Request pertaining to a Large Generating Facility that are included in the Transmission Provider's Tariff.~~

System Protection Facilities shall mean the equipment, including necessary protection signal communications equipment, ~~required to protect~~that protects (1) the ~~Transmission Provider~~Participating TO's Transmission System, Participating TO's Interconnection Facilities, CAISO Controlled Grid, and Affected Systems from faults or other electrical disturbances occurring at the Generating Facility and (2) the Generating Facility from faults or other electrical system disturbances occurring on the ~~Transmission Provider's Transmission System~~CAISO Controlled Grid, Participating TO's Interconnection Facilities, and Affected Systems or on other delivery systems or other generating systems to which the ~~Transmission Provider's Transmission System~~CAISO Controlled Grid is directly connected.

~~Tariff shall mean the Transmission Provider's Tariff through which open access transmission service and Interconnection Service are offered, as filed with FERC, and as amended or supplemented from time to time, or any successor tariff.~~

~~Transmission Owner shall mean an entity that owns, leases or otherwise possesses an interest in the portion of the Transmission System at the Point of Interconnection and may be a Party to the Standard Large Generator Interconnection Agreement to the extent necessary.~~

~~Transmission Provider shall mean the public utility (or its designated agent) that owns, controls, or operates transmission or distribution facilities used for the transmission of electricity in interstate commerce and provides transmission service under the Tariff. The term Transmission Provider should be read to include the Transmission Owner when the Transmission Owner is separate from the Transmission Provider.~~

~~Transmission Provider's Interconnection Facilities shall mean all facilities and equipment owned, controlled or operated by the Transmission Provider from the Point of Change of Ownership to the Point of Interconnection as identified in Appendix A to the Standard Large Generator Interconnection Agreement, including any modifications, additions or upgrades to such facilities and equipment. Transmission Provider's Interconnection Facilities are sole use facilities and shall not include Distribution Upgrades, Stand Alone Network Upgrades or Network Upgrades.~~

Transmission Control Agreement shall mean CAISO FERC Electric Tariff No.

7.

~~Transmission System shall mean the facilities owned, controlled or operated by the Transmission Provider or Transmission Owner that are used to provide transmission service under the Tariff.~~

Trial Operation shall mean the period during which the Interconnection Customer is engaged in on-site test operations and commissioning of ~~the~~an Electric Generating Facility Unit prior to Commercial Operation.

~~Article 2. Effective Date, Term, and Termination~~

ARTICLE 2. EFFECTIVE DATE, TERM AND TERMINATION

- 2.1 Effective Date.** This LGIA shall become effective upon execution by ~~the~~all Parties subject to acceptance by FERC (if applicable), or if filed unexecuted, upon the date specified by FERC. ~~Transmission Provider~~The CAISO and Participating TO shall promptly file this LGIA with FERC upon execution in accordance with Article 3.1, if required.
- 2.2 Term of Agreement.** Subject to the provisions of Article 2.3, this LGIA shall remain in effect for a period of ~~ten (10)~~ _____ years from the Effective Date (Term Specified in Individual Agreements to be ten (10) years or such other longer period as the Interconnection Customer may request (~~Term to be specified in individual agreements~~) and shall be automatically renewed for each successive one-year period thereafter.

2.3 Termination Procedures.

2.3.1 Written Notice. This LGIA may be terminated by the Interconnection Customer after giving ~~Transmission Provider~~the CAISO and the Participating TO ninety (90) Calendar Days advance written notice, or by ~~Transmission Provider~~the CAISO and the Participating TO notifying FERC after the Generating Facility permanently ceases Commercial Operation.

2.3.2 Default. ~~Either~~A Party may terminate this LGIA in accordance with Article 17.

2.3.3 Suspension of Work. This LGIA may be deemed terminated in accordance with Article 5.16.

2.3.4 Notwithstanding Articles ~~2.3.1 and~~2.3.1, 2.3.2, and 2.3.3, no termination shall become effective until the Parties have complied with all Applicable Laws and Regulations applicable to such termination, including the filing with FERC of a notice of termination of this LGIA (if applicable), which notice has been accepted for filing by FERC, and the Interconnection Customer has fulfilled its termination cost obligations under Article 2.4.

2.4 Termination Costs. ~~If a Party elects to terminate this Agreement~~Immediately upon the other Parties' receipt of a notice of the termination of this LGIA pursuant to Article 2.3 above, ~~each Party shall pay~~the CAISO and the Participating TO will determine the total cost responsibility of the Interconnection Customer. If, as of the date of the other Parties' receipt of the notice of termination, the Interconnection Customer has not already paid its share of Network Upgrade costs, as set forth in Appendix G to this LGIA, the Participating TO will liquidate the Interconnection Customer's Interconnection Financial Security associated with its cost responsibility for Network Upgrades, in accordance with Section 9.4 of the LGIP.

The Interconnection Customer will also be responsible for all costs incurred or irrevocably committed to be incurred in association with the construction of the Participating TO's Interconnection Facilities (including any cancellation costs relating to orders or contracts for Interconnection Facilities and equipment) or charges assessed by the other Party, as of the date of the other Party's receipt of such notice of termination, that are and other such expenses, including any Distribution Upgrades for which the Participating TO or CAISO has incurred expenses or has irrevocably committed to incur expenses and has not been reimbursed by the Interconnection Customer, as of the date of the other Parties' receipt of the notice of termination, subject to the limitations set forth in this Article 2.4. Nothing in this Article 2.4 shall limit the Parties' rights under Article 17. If, as of the date of the other Parties' receipt of the notice of termination, the Interconnection Customer has not already reimbursed the Participating TO and the CAISO for costs incurred to construct the Participating TO's Interconnection Facilities, the Participating TO will liquidate the Interconnection Customer's Interconnection Financial Security associated with the construction of the

Participating TO's Interconnection Facilities, in accordance with Section 9.4 of the LGIP. If the amount of the Interconnection Financial Security liquidated by the Participating TO under this Article 2.4 is insufficient to compensate the CAISO and the Participating TO for actual costs associated with the construction of the Participating TO's Interconnection Facilities contemplated in this Article, any additional amounts will be the responsibility of the Terminating Party under this LGIA. In Interconnection Customer, subject to the provisions of Section 9.4 of the LGIP. Any such additional amounts due from the Interconnection Customer beyond the amounts covered by its Interconnection Financial Security will be due to the Participating TO immediately upon termination of this LGIA in accordance with Section 9.4 of the LGIP.

If the amount of the Interconnection Financial Security exceeds the Interconnection Customer's cost responsibility under Section 9.4 of the LGIP, any excess amount will be released to the Interconnection Customer in accordance with Section 9.4 of the LGIP.

2.4.1 Notwithstanding the foregoing, in the event of termination by a Party, ~~the~~ all Parties shall use commercially Reasonable Efforts to mitigate the costs, damages and charges arising as a consequence of termination. ~~Upon termination of this LGIA, unless otherwise ordered or approved by FERC: 2.4.1~~ With respect to any portion of ~~Transmission Provider~~ the Participating TO's Interconnection Facilities that have not yet been constructed or installed, ~~Transmission Provider~~ the Participating TO shall to the extent possible and with the Interconnection Customer's authorization cancel any pending orders of, or return, any materials or equipment for, or contracts for construction of, such facilities; provided that in the event the Interconnection Customer elects not to authorize such cancellation, the Interconnection Customer shall assume all payment obligations with respect to such materials, equipment, and contracts, and ~~Transmission Provider~~ the Participating TO shall deliver such material and equipment, and, if necessary, assign such contracts, to the Interconnection Customer as soon as practicable, at the Interconnection Customer's expense. To the extent that the Interconnection Customer has already paid ~~Transmission Provider~~ the Participating TO for any or all such costs of materials or equipment not taken by the Interconnection Customer, ~~Transmission Provider~~ the Participating TO shall promptly refund such amounts to the Interconnection Customer, less any costs, including penalties, incurred by ~~Transmission Provider~~ the Participating TO to cancel any pending orders of or return such materials, equipment, or contracts.

~~If an Interconnection Customer terminates this LGIA, it shall be responsible for all costs incurred in association with that Interconnection Customer's interconnection, including any cancellation costs relating to orders or contracts for Interconnection Facilities and equipment, and other expenses including any Network Upgrades for which Transmission Provider has incurred expenses and has not been reimbursed by Interconnection Customer.~~

- 2.4.2** ~~Transmission Provider~~ The Participating TO may, at its option, retain any portion of such materials, equipment, or facilities that the Interconnection Customer chooses not to accept delivery of, in which case ~~Transmission Provider~~ the Participating TO shall be responsible for all costs associated with procuring such materials, equipment, or facilities.
- 2.4.3** With respect to any portion of the Interconnection Facilities, and any other facilities already installed or constructed pursuant to the terms of this LGIA, Interconnection Customer shall be responsible for all costs associated with the removal, relocation or other disposition or retirement of such materials, equipment, or facilities.
- 2.5** **Disconnection.** Upon termination of this LGIA, the Parties will take all appropriate steps to disconnect the Large Generating Facility from the Participating TO's Transmission System. All costs required to effectuate such disconnection shall be borne by the terminating Party, unless such termination resulted from the non-terminating Party's Default of this LGIA or such non-terminating Party otherwise is responsible for these costs under this LGIA.
- 2.6** **Survival.** This LGIA shall continue in effect after termination to the extent necessary to provide for final billings and payments and for costs incurred hereunder, including billings and payments pursuant to this LGIA; to permit the determination and enforcement of liability and indemnification obligations arising from acts or events that occurred while this LGIA was in effect; and to permit each Party to have access to the lands of the other ~~Party~~ Parties pursuant to this LGIA or other applicable agreements, to disconnect, remove or salvage its own facilities and equipment.

~~Article 3. — Regulatory Filings~~

ARTICLE 3. REGULATORY FILINGS AND CAISO TARIFF COMPLIANCE

- 3.1** **Filing.** ~~Transmission Provider~~ The Participating TO and the CAISO shall file this LGIA (and any amendment hereto) with the appropriate Governmental Authority(ies), if required. The Interconnection Customer may request that any information so provided be subject to the confidentiality provisions of Article 22. If the Interconnection Customer has executed this LGIA, or any amendment thereto, the Interconnection Customer shall reasonably cooperate with ~~Transmission Provider~~ the Participating TO and CAISO with respect to such filing and to provide any information reasonably requested by ~~Transmission Provider~~ the Participating TO or CAISO needed to comply with applicable regulatory requirements.
- 3.2** **Agreement Subject to CAISO Tariff.** The Interconnection Customer will comply with all applicable provisions of the CAISO Tariff, including the LGIP.

3.3 Relationship Between this LGIA and the CAISO Tariff. With regard to rights and obligations between the Participating TO and the Interconnection Customer, if and to the extent a matter is specifically addressed by a provision of this LGIA (including any appendices, schedules or other attachments to this LGIA), the provisions of this LGIA shall govern. If and to the extent a provision of this LGIA is inconsistent with the CAISO Tariff and dictates rights and obligations between the CAISO and the Participating TO or the CAISO and the Interconnection Customer, the CAISO Tariff shall govern.

3.4 Relationship Between this LGIA and the QF PGA. With regard to the rights and obligations of a Qualifying Facility that has entered into a QF PGA with the CAISO and has entered into this LGIA, if and to the extent a matter is specifically addressed by a provision of the QF PGA that is inconsistent with this LGIA, the terms of the QF PGA shall govern.

Article 4. — Scope of Service

ARTICLE 4. SCOPE OF SERVICE

4.1 Interconnection Service. ~~Product Options. Interconnection Customer has selected the following (checked) type of Interconnection Service:~~

~~4.1.1 — Energy Resource Interconnection Service. 4.1.1.1 — The Product. Energy Resource~~ Interconnection Service allows the Interconnection Customer to connect the Large Generating Facility to the Participating TO's Transmission System and be eligible to deliver the Large Generating Facility's output using the ~~existing firm or non-firm~~ available capacity of the ~~Transmission System on an "as available" basis~~ CAISO Controlled Grid. To the extent the Interconnection Customer wants to receive ~~Energy Resource~~ Interconnection Service, ~~Transmission Provider~~ the Participating TO shall construct facilities identified in ~~Attachment A~~ Appendices A and C that the Participating TO is responsible to construct.

~~4.1.1.2 — Transmission Delivery Service Implications. Under Energy Resource Interconnection Service, Interconnection Customer will be eligible to inject power from the Large Generating Facility into and deliver power across the interconnecting Transmission Provider's Transmission System on an "as available" basis up to the amount of MWs identified in the applicable stability and steady-state studies to the extent the upgrades initially required to qualify for Energy Resource Interconnection Service have been constructed. Where eligible to do so (e.g., PJM, ISO-NE, NYISO), Interconnection Customer may place a bid to sell into the market up to the maximum identified Large Generating Facility output, subject to any conditions specified in the interconnection service approval, and the Large Generating Facility will be dispatched to the extent Interconnection Customer's bid clears. In all other instances, no transmission delivery service from the Large Generating Facility is assured, but Interconnection Customer may obtain Point-to-Point Transmission Service, Network Integration Transmission Service, or be used for secondary network~~

~~transmission service, pursuant to Transmission Provider's Tariff, up to the maximum output identified in the stability and steady state studies. In those instances, in order for Interconnection Customer to obtain the right to deliver or inject energy beyond the Large Generating Facility Point of Interconnection or to improve its ability to do so, transmission delivery service must be obtained pursuant to the provisions of Transmission Provider's Tariff. The Interconnection Customer's ability to inject its Large Generating Facility output beyond the Point of Interconnection, therefore, will depend on the existing capacity of Transmission Provider's Transmission System at such time as a transmission service request is made that would accommodate such delivery. The provision of firm Point-to-Point Transmission Service or Network Integration Transmission Service may require the construction of additional Network Upgrades.~~

~~4.1.2 Network Resource Interconnection Service.~~

~~**4.1.2.1 The Product.** Transmission Provider must conduct the necessary studies and construct the Network Upgrades needed to integrate the Large Generating Facility (1) in a manner comparable to that in which Transmission Provider integrates its generating facilities to serve native load customers; or (2) in an ISO or RTO with market-based congestion management, in the same manner as all Network Resources. To the extent Interconnection Customer wants to receive Network Resource Interconnection Service, Transmission Provider shall construct the facilities identified in Attachment A to this LGIA.~~

~~**4.1.2.2 Transmission Delivery Service Implications.** Network Resource Interconnection Service allows Interconnection Customer's Large Generating Facility to be designated by any Network Customer under the Tariff on Transmission Provider's Transmission System as a Network Resource, up to the Large Generating Facility's full output, on the same basis as existing Network Resources interconnected to Transmission Provider's Transmission System, and to be studied as a Network Resource on the assumption that such a designation will occur. Although Network Resource Interconnection Service does not convey a reservation of transmission service, any Network Customer under the Tariff can utilize its network service under the Tariff to obtain delivery of energy from the interconnected Interconnection Customer's Large Generating Facility in the same manner as it accesses Network Resources. A Large Generating Facility receiving Network Resource Interconnection Service may also be used to provide Ancillary Services after technical studies and/or periodic analyses are performed with respect to the Large Generating Facility's ability to provide any applicable Ancillary Services, provided that such studies and analyses have been or would be required in connection with the provision of such Ancillary Services by any existing Network Resource. However, if an Interconnection Customer's Large Generating Facility has not been designated as a Network Resource by any load, it cannot be required to provide Ancillary Services except to the extent such requirements extend to all generating facilities that are similarly situated. The provision of Network Integration Transmission Service or firm Point-to-Point Transmission Service may require additional studies and the construction of additional upgrades. Because such studies and upgrades would be associated with a request for delivery service under the Tariff, cost responsibility for the~~

~~studies and upgrades would be in accordance with FERC's policy for pricing transmission delivery services.~~

~~Network Resource~~ Interconnection Service does not necessarily provide the Interconnection Customer with the capability to physically deliver the output of its Large Generating Facility to any particular load on ~~Transmission Provider's Transmission System~~the CAISO Controlled Grid without incurring congestion costs. In the event of transmission constraints on ~~Transmission Provider's Transmission System~~the CAISO Controlled Grid, the Interconnection Customer's Large Generating Facility shall be subject to the applicable congestion management procedures in ~~Transmission Provider's Transmission System~~the CAISO Tariff in the same manner as ~~Network Resources~~all other resources.

~~There is no requirement either at the time of study or interconnection, or at any point in the future, that Interconnection Customer's Large Generating Facility be designated as a Network Resource by a Network Service Customer under the Tariff or that Interconnection Customer identify a specific buyer (or sink). To the extent a Network Customer does designate the Large Generating Facility as a Network Resource, it must do so pursuant to Transmission Provider's Tariff.~~

~~Once an Interconnection Customer satisfies the requirements for obtaining Network Resource Interconnection Service, any future transmission service request for delivery from the Large Generating Facility within Transmission Provider's Transmission System of any amount of capacity and/or energy, up to the amount initially studied, will not require that any additional studies be performed or that any further upgrades associated with such Large Generating Facility be undertaken, regardless of whether or not such Large Generating Facility is ever designated by a Network Customer as a Network Resource and regardless of changes in ownership of the Large Generating Facility. However, the reduction or elimination of congestion or redispatch costs may require additional studies and the construction of additional upgrades.~~

~~To the extent Interconnection Customer enters into an arrangement for long-term transmission service for deliveries from the Large Generating Facility outside Transmission Provider's Transmission System, such request may require additional studies and upgrades in order for Transmission Provider to grant such request.~~

4.2 Provision of Service. ~~Transmission Provider~~The Participating TO and the CAISO shall provide Interconnection Service for the Large Generating Facility ~~at the Point of Interconnection.~~

4.3 Performance Standards. Each Party shall perform all of its obligations under this LGIA in accordance with Applicable Laws and Regulations, Applicable Reliability Standards, and Good Utility Practice, and to the extent a Party is required or prevented or limited in taking any action by such regulations and standards, such Party shall not be deemed to be in Breach of this LGIA for its compliance therewith. If such Party is ~~a Transmission Provider or Transmission~~

~~Owner~~the CAISO or Participating TO, then that Party shall amend the LGIA and submit the amendment to FERC for approval.

- 4.4 No Transmission-Delivery Service.** The execution of this LGIA does not constitute a request for, nor the provision of, any transmission-~~delivery~~ service under ~~Transmission Provider's~~the CAISO Tariff, and does not convey any right to deliver electricity to any specific customer or ~~Point~~point of ~~Delivery~~delivery.
- 4.5 Interconnection Customer Provided Services.** The services provided by Interconnection Customer under this LGIA are set forth in Article 9.6 and Article 13.5.1. Interconnection Customer shall be paid for such services in accordance with Article 11.6.

~~Article 5. Interconnection Facilities Engineering, Procurement, and Construction~~
ARTICLE 5. INTERCONNECTION FACILITIES ENGINEERING, PROCUREMENT, AND CONSTRUCTION

Interconnection Facilities, Network Upgrades, and Distribution Upgrades shall be studied, designed, and constructed pursuant to Good Utility Practice. Such studies, design and construction shall be based on the assumed accuracy and completeness of all technical information received by the Participating TO and the CAISO from the Interconnection Customer associated with interconnecting the Large Generating Facility.

- 5.1 Options.** Unless otherwise mutually agreed ~~to-between~~among the Parties, the Interconnection Customer shall select the In-Service Date, Initial Synchronization Date, and Commercial Operation Date; and either Standard Option or Alternate Option set forth below for completion of ~~Transmission Provider~~the Participating TO's Interconnection Facilities and Network Upgrades as set forth in Appendix A, Interconnection Facilities ~~and~~, Network Upgrades, and Distribution Upgrades, and such dates and selected option shall be set forth in Appendix B, Milestones.
- 5.1.1 Standard Option.** ~~Transmission Provider~~The Participating TO shall design, procure, and construct ~~Transmission Provider~~the Participating TO's Interconnection Facilities ~~and~~, Network Upgrades, and Distribution Upgrades, using Reasonable Efforts to complete ~~Transmission Provider~~the Participating TO's Interconnection Facilities ~~and~~, Network Upgrades, and Distribution Upgrades by the dates set forth in Appendix B, Milestones. ~~Transmission Provider~~The Participating TO shall not be required to undertake any action which is inconsistent with its standard safety practices, its material and equipment specifications, its design criteria and construction procedures, its labor agreements, and Applicable Laws and Regulations. In the event ~~Transmission Provider~~the Participating TO reasonably expects that it will not be able to complete ~~Transmission Provider~~the Participating TO's Interconnection Facilities ~~and~~, Network Upgrades, and Distribution Upgrades by the specified dates, ~~Transmission Provider~~the Participating TO

shall promptly provide written notice to the Interconnection Customer and the CAISO and shall undertake Reasonable Efforts to meet the earliest dates thereafter.

5.1.2 Alternate Option. If the dates designated by the Interconnection Customer are acceptable to ~~Transmission Provider, Transmission Provider~~the Participating TO, the Participating TO shall so notify the Interconnection Customer within thirty (30) Calendar Days, and shall assume responsibility for the design, procurement and construction of ~~Transmission Provider~~the Participating TO's Interconnection Facilities by the designated dates.

If ~~Transmission Provider~~the Participating TO subsequently fails to complete ~~Transmission Provider~~the Participating TO's Interconnection Facilities by the In-Service Date, to the extent necessary to provide back feed power; or fails to complete Network Upgrades by the Initial Synchronization Date to the extent necessary to allow for Trial Operation at full power output, unless other arrangements are made by the Parties for such Trial Operation; or fails to complete the Network Upgrades by the Commercial Operation Date, as such dates are reflected in Appendix B, Milestones; ~~Transmission Provider~~the Participating TO shall pay the Interconnection Customer liquidated damages in accordance with Article 5.3, Liquidated Damages, provided, however, the dates designated by the Interconnection Customer shall be extended day for day for each day that the ~~applicable RTO or ISO~~CAISO refuses to grant clearances to install equipment.

5.1.3 Option to Build. If the dates designated by the Interconnection Customer are not acceptable to ~~Transmission Provider, Transmission Provider~~the Participating TO, the Participating TO shall so notify the Interconnection Customer within thirty (30) Calendar Days, and unless the Parties agree otherwise, the Interconnection Customer shall have the option to assume responsibility for the design, procurement and construction of ~~Transmission Provider~~the Participating TO's Interconnection Facilities and Stand Alone Network Upgrades ~~on the dates specified in Article 5.1.2. Transmission Provider.~~ If the Interconnection Customer elects to exercise its option to assume responsibility for the design, procurement and construction of the Participating TO's Interconnection Facilities and Stand Alone Network Upgrades, it shall so notify the Participating TO within thirty (30) Calendar Days of receipt of the Participating TO's notification that the designated dates are not acceptable to the Participating TO. The Participating TO, CAISO, and Interconnection Customer must agree as to what constitutes Stand Alone Network Upgrades and identify such Stand Alone Network Upgrades in Appendix A to this LGIA. Except for Stand Alone Network Upgrades, the Interconnection Customer shall have no right to construct Network Upgrades under this option.

5.1.4 Negotiated Option. If the Interconnection Customer elects not to exercise its option under Article 5.1.3, Option to Build, the Interconnection Customer shall so notify ~~Transmission Provider~~the Participating TO within thirty (30) Calendar Days of receipt of the Participating TO's notification that the designated dates are not acceptable to the Participating TO, and the Parties shall in good faith attempt to negotiate terms and conditions (including revision of the specified dates and liquidated damages, the provision of incentives or the procurement and construction of a portion of ~~Transmission Provider~~the Participating TO's Interconnection Facilities and Stand Alone Network Upgrades by the Interconnection Customer) pursuant to which ~~Transmission Provider~~the Participating TO is responsible for the design, procurement and construction of ~~Transmission Provider~~the Participating TO's Interconnection Facilities and Network Upgrades. If the Parties are unable to reach agreement on such terms and conditions, ~~Transmission Provider~~the Participating TO shall assume responsibility for the design, procurement and construction of ~~Transmission Provider~~the Participating TO's Interconnection Facilities and Network Upgrades pursuant to Article 5.1.1, Standard Option.

5.2 General Conditions Applicable to Option to Build. If the Interconnection Customer assumes responsibility for the design, procurement and construction of ~~Transmission Provider~~the Participating TO's Interconnection Facilities and Stand Alone Network Upgrades,

(1) the Interconnection Customer shall engineer, procure equipment, and construct ~~Transmission Provider~~the Participating TO's Interconnection Facilities and Stand Alone Network Upgrades (or portions thereof) using Good Utility Practice and using standards and specifications provided in advance by ~~Transmission Provider~~the Participating TO;

(2) The Interconnection Customer's engineering, procurement and construction of ~~Transmission Provider~~the Participating TO's Interconnection Facilities and Stand Alone Network Upgrades shall comply with all requirements of law ~~and Applicable Reliability Standards~~ to which ~~Transmission Provider~~the Participating TO would be subject in the engineering, procurement or construction of ~~Transmission Provider~~the Participating TO's Interconnection Facilities and Stand Alone Network Upgrades;

(3) ~~Transmission Provider~~the Participating TO shall review ~~and approve~~, and the Interconnection Customer shall obtain the Participating TO's approval of, the engineering design, equipment acceptance tests, and the construction of ~~Transmission Provider~~the Participating TO's Interconnection Facilities and Stand Alone Network Upgrades, which approval shall not be unreasonably withheld, and the CAISO may, at its option, review the engineering design, equipment acceptance tests, and the construction of the Participating TO's Interconnection Facilities and Stand Alone Network Upgrades;

(4) prior to commencement of construction, ~~the~~ Interconnection Customer shall provide to ~~Transmission Provider~~ the Participating TO, with a copy to the CAISO for informational purposes, a schedule for construction of ~~Transmission Provider~~ the Participating TO's Interconnection Facilities and Stand Alone Network Upgrades, and shall promptly respond to requests for information from ~~Transmission Provider~~ the Participating TO;

(5) at any time during construction, ~~Transmission Provider~~ the Participating TO shall have the right to gain unrestricted access to ~~Transmission Provider~~ the Participating TO's Interconnection Facilities and Stand Alone Network Upgrades and to conduct inspections of the same;

(6) at any time during construction, should any phase of the engineering, equipment procurement, or construction of ~~Transmission Provider~~ the Participating TO's Interconnection Facilities and Stand Alone Network Upgrades not meet the standards and specifications provided by ~~Transmission Provider~~ the Participating TO, the Interconnection Customer shall be obligated to remedy deficiencies in that portion of ~~Transmission Provider~~ the Participating TO's Interconnection Facilities and Stand Alone Network Upgrades;

(7) the Interconnection Customer shall indemnify ~~Transmission Provider~~ the CAISO and Participating TO for claims arising from the Interconnection Customer's construction of ~~Transmission Provider~~ the Participating TO's Interconnection Facilities and Stand Alone Network Upgrades under the terms and procedures applicable to Article 18.1 Indemnity;

(8) The Interconnection Customer shall transfer control of ~~Transmission Provider~~ the Participating TO's Interconnection Facilities ~~and to the Participating TO and shall transfer Operational Control of~~ Stand Alone Network Upgrades to ~~Transmission Provider~~ the CAISO;

(9) Unless the Parties otherwise agree, the Interconnection Customer shall transfer ownership of ~~Transmission Provider~~ the Participating TO's Interconnection Facilities and Stand- Alone Network Upgrades to ~~Transmission Provider~~ the Participating TO. As soon as reasonably practicable, but within twelve months after completion of the construction of the Participating TO's Interconnection Facilities and Stand Alone Network Upgrades, the Interconnection Customer shall provide an invoice of the final cost of the construction of the Participating TO's Interconnection Facilities and Stand Alone Network Upgrades to the Participating TO, which invoice shall set forth such costs in sufficient detail to enable the Participating TO to reflect the proper costs of such facilities in its transmission rate base and to identify the investment upon which refunds will be provided;

(10) ~~Transmission Provider~~ the Participating TO shall ~~approve and~~ accept for operation and maintenance ~~Transmission Provider~~ the Participating TO's Interconnection Facilities and Stand Alone Network Upgrades to the extent engineered, procured, and constructed in accordance with this Article 5.2; and

(11) The Interconnection Customer's engineering, procurement and construction of the Participating TO's Interconnection Facilities and Stand Alone Network Upgrades shall comply with all requirements of the "Option to Build" conditions set forth in Appendix C. Interconnection Customer shall deliver to ~~Transmission Provider~~ "the Participating TO "as-built" drawings, information, and any other documents that are reasonably required by ~~Transmission Provider~~ the Participating TO to assure that the Interconnection Facilities and Stand-Alone Network Upgrades are built to the standards and specifications required by ~~Transmission Provider~~ the Participating TO.

5.3 Liquidated Damages. The actual damages to the Interconnection Customer, in the event ~~Transmission Provider~~ the Participating TO's Interconnection Facilities or Network Upgrades are not completed by the dates designated by the Interconnection Customer and accepted by ~~Transmission Provider~~ the Participating TO pursuant to subparagraphs 5.1.2 or 5.1.4, above, may include Interconnection Customer's fixed operation and maintenance costs and lost opportunity costs. Such actual damages are uncertain and impossible to determine at this time. Because of such uncertainty, any liquidated damages paid by ~~Transmission Provider to~~ the Participating TO to the Interconnection Customer in the event that ~~Transmission Provider~~ the Participating TO does not complete any portion of ~~Transmission Provider~~ the Participating TO's Interconnection Facilities or Network Upgrades by the applicable dates, shall be an amount equal to ½ of 1 percent per day of the actual cost of ~~Transmission Provider~~ the Participating TO's Interconnection Facilities and Network Upgrades, in the aggregate, for which ~~Transmission Provider~~ the Participating TO has assumed responsibility to design, procure and construct.

However, in no event shall the total liquidated damages exceed 20 percent of the actual cost of ~~Transmission Provider~~ the Participating TO's Interconnection Facilities and Network Upgrades for which ~~Transmission Provider~~ the Participating TO has assumed responsibility to design, procure, and construct. The foregoing payments will be made by ~~Transmission Provider to~~ the Participating TO to the Interconnection Customer as just compensation for the damages caused to the Interconnection Customer, which actual damages are uncertain and impossible to determine at this time, and as reasonable liquidated damages, but not as a penalty or a method to secure performance of this LGIA. Liquidated damages, when the Parties agree to them, are the exclusive remedy for the ~~Transmission Provider~~ Participating TO's failure to meet its schedule.

No liquidated damages shall be paid to the Interconnection Customer if: (1) the Interconnection Customer is not ready to commence use of ~~Transmission Provider~~the Participating TO's Interconnection Facilities or Network Upgrades to take the delivery of power for the ~~Large Electric~~ Generating Facility Unit's Trial Operation or to export power from the ~~Large Electric~~ Generating Facility Unit on the specified dates, unless the Interconnection Customer would have been able to commence use of ~~Transmission Provider~~the Participating TO's Interconnection Facilities or Network Upgrades to take the delivery of power for ~~Large Electric~~ Generating Facility Unit's Trial Operation or to export power from the ~~Large Electric~~ Generating Facility Unit, but for ~~Transmission Provider~~the Participating TO's delay; (2) ~~Transmission Provider~~the Participating TO's failure to meet the specified dates is the result of the action or inaction of the Interconnection Customer or any other ~~Interconnection Customer~~interconnection customer who has entered into an ~~LGIA with Transmission Provider~~interconnection agreement with the CAISO and/or Participating TO, action or inaction by the CAISO, or any cause beyond ~~Transmission Provider~~the Participating TO's reasonable control or reasonable ability to cure; (3) the Interconnection Customer has assumed responsibility for the design, procurement and construction of ~~Transmission Provider~~the Participating TO's Interconnection Facilities and Stand Alone Network Upgrades; or (4) the Parties have otherwise agreed.

In no event shall the CAISO have any responsibility or liability to the Interconnection Customer for liquidated damages pursuant to the provisions of this Article 5.3.

- 5.4 Power System Stabilizers.** The Interconnection Customer shall procure, install, maintain and operate Power System Stabilizers in accordance with Applicable Reliability Standards, the guidelines and procedures established by the Applicable Reliability Council. ~~Transmission Provider,~~ and the provisions of Section 4.6.5.1 of the CAISO Tariff. The CAISO reserves the right to ~~reasonably~~ establish reasonable minimum acceptable settings for any installed Power System Stabilizers, subject to the design and operating limitations of the Large Generating Facility. If the Large Generating Facility's Power System Stabilizers are removed from service or not capable of automatic operation, the Interconnection Customer shall immediately notify ~~Transmission Provider's system operator, or its designated representative~~the CAISO and the Participating TO and restore the Power System Stabilizers to operation as soon as possible. The CAISO shall have the right to order the reduction in output or disconnection of the Large Generating Facility if the reliability of the CAISO Controlled Grid would be adversely affected as a result of improperly tuned Power System Stabilizers. The requirements of this ~~paragraph~~Article 5.4 shall not apply to wind generators of the induction type.
- 5.5 Equipment Procurement.** If responsibility for construction of ~~Transmission Provider~~the Participating TO's Interconnection Facilities or Network Upgrades is to

be borne by ~~Transmission Provider, then Transmission Provider~~ the Participating TO, then the Participating TO shall commence design of ~~Transmission Provider~~ the Participating TO's Interconnection Facilities or Network Upgrades and procure necessary equipment as soon as practicable after all of the following conditions are satisfied, unless the Parties otherwise agree in writing:

5.5.1 ~~Transmission Provider~~ The CAISO, in coordination with the applicable Participating TO(s), has completed the ~~Facilities~~ Phase II Interconnection Study pursuant to the Large Generator Interconnection Facilities Study Process Agreement;

5.5.2 ~~Transmission Provider~~ The Participating TO has received written authorization to proceed with design and procurement from the Interconnection Customer by the date specified in Appendix B, Milestones; and

5.5.3 The Interconnection Customer has provided security to ~~Transmission Provider~~ the Participating TO in accordance with Article 11.5 by the dates specified in Appendix B, Milestones.

5.6 Construction Commencement. ~~Transmission Provider~~ The Participating TO shall commence construction of ~~Transmission Provider~~ the Participating TO's Interconnection Facilities and Network Upgrades for which it is responsible as soon as practicable after the following additional conditions are satisfied:

5.6.1 Approval of the appropriate Governmental Authority has been obtained for any facilities requiring regulatory approval;

5.6.2 Necessary real property rights and rights-of-way have been obtained, to the extent required for the construction of a discrete aspect of ~~Transmission Provider~~ the Participating TO's Interconnection Facilities and Network Upgrades;

5.6.3 ~~Transmission Provider~~ The Participating TO has received written authorization to proceed with construction from the Interconnection Customer by the date specified in Appendix B, Milestones; and

5.6.4 The Interconnection Customer has provided payment and security to ~~Transmission Provider~~ the Participating TO in accordance with Article 11.5 by the dates specified in Appendix B, Milestones.

5.7 Work Progress. The Parties will keep each other advised periodically as to the progress of their respective design, procurement and construction efforts. ~~Either~~ Any Party may, at any time, request a progress report from ~~the other~~ another Party. If, at any time, the Interconnection Customer determines that the completion of ~~Transmission Provider~~ the Participating TO's Interconnection Facilities will not be required until after the specified In-Service Date, the Interconnection

Customer will provide written notice to ~~Transmission Provider~~the Participating TO and CAISO of such later date upon which the completion of ~~Transmission Provider~~the Participating TO's Interconnection Facilities will be required.

- 5.8 Information Exchange.** As soon as reasonably practicable after the Effective Date, the Parties shall exchange information regarding the design and compatibility of the ~~Parties'~~Interconnection Customer's Interconnection Facilities and Participating TO's Interconnection Facilities and compatibility of the Interconnection Facilities with ~~Transmission Provider~~the Participating TO's Transmission System, and shall work diligently and in good faith to make any necessary design changes.
- 5.9 Limited Operation.** If any of ~~Transmission Provider~~the Participating TO's Interconnection Facilities or Network Upgrades are not reasonably expected to be completed prior to the Commercial Operation Date of the ~~Large Electric Generating Facility, Transmission Provider~~Unit, the Participating TO and/or CAISO, as applicable, shall, upon the request and at the expense of the Interconnection Customer, perform operating studies on a timely basis to determine the extent to which the ~~Large Electric Generating Facility~~Unit and the Interconnection Customer's Interconnection Facilities may operate prior to the completion of ~~Transmission Provider~~the Participating TO's Interconnection Facilities or Network Upgrades consistent with Applicable Laws and Regulations, Applicable Reliability Standards, Good Utility Practice, and this LGIA. ~~Transmission Provider~~The Participating TO and CAISO shall permit Interconnection Customer to operate the ~~Large Electric Generating Facility~~Unit and the Interconnection Customer's Interconnection Facilities in accordance with the results of such studies.
- 5.10 Interconnection Customer's Interconnection Facilities (~~ICIF~~).** The Interconnection Customer shall, at its expense, design, procure, construct, own and install the ~~ICIF~~Interconnection Customer's Interconnection Facilities, as set forth in Appendix A, ~~Interconnection Facilities, Network Upgrades and Distribution Upgrades.~~
- 5.10.1 Large Generating Facility and Interconnection Customer's ~~Interconnection Facility Specifications.~~'s Interconnection Facilities Specifications.** In addition to the Interconnection Customer's responsibility to submit technical data with its Interconnection Request as required by Section 3.5.1 of the LGIP, the Interconnection Customer shall submit ~~initial~~all remaining necessary specifications for the ~~ICIF~~Interconnection Customer's Interconnection Facilities and Large Generating Facility, including System Protection Facilities, to ~~Transmission Provider~~the Participating TO and the CAISO at least one hundred eighty (180) Calendar Days prior to the Initial Synchronization Date; and final specifications for review and comment at least ninety (90) Calendar Days prior to the Initial Synchronization Date. ~~Transmission Provider~~The Participating TO and the CAISO shall review such specifications pursuant to this LGIA and the LGIP to ensure that the ~~ICIF~~Interconnection

Customer's Interconnection Facilities and Large Generating Facility are compatible with the technical specifications, operational control, ~~and safety requirements of Transmission Provider~~, and any other applicable requirements of the Participating TO and the CAISO and comment on such specifications within thirty (30) Calendar Days of the Interconnection Customer's submission. All specifications provided hereunder shall be deemed confidential.

5.10.2 ~~Transmission Provider's Review~~ ~~Transmission Provider~~ Participating TO's and CAISO's Review. The Participating TO's and the CAISO's review of the Interconnection Customer's final specifications shall not be construed as confirming, endorsing, or providing a warranty as to the design, fitness, safety, durability or reliability of the Large Generating Facility, or the ~~ICIF~~ Interconnection Customer's Interconnection Facilities. Interconnection Customer shall make such changes to the ~~ICIF~~ Interconnection Customer's Interconnection Facilities as may reasonably be required by ~~Transmission Provider~~ the Participating TO or the CAISO, in accordance with Good Utility Practice, to ensure that the ~~ICIF~~ Interconnection Customer's Interconnection Facilities are compatible with the technical specifications, ~~operational control~~ Operational Control, and safety requirements of ~~Transmission Provider~~ the Participating TO or the CAISO.

5.10.3 ~~ICIF~~ Interconnection Customer's Interconnection Facilities Construction. The ~~ICIF~~ Interconnection Customer's Interconnection Facilities shall be designed and constructed in accordance with Good Utility Practice. Within one hundred twenty (120) Calendar Days after the Commercial Operation Date, unless the ~~Parties~~ Participating TO and Interconnection Customer agree on another mutually acceptable deadline, the Interconnection Customer shall deliver to ~~Transmission Provider~~ "the Participating TO and CAISO "as-built" drawings, information and documents for the ~~ICIF~~ Interconnection Customer's Interconnection Facilities and the Electric Generating Unit(s), such as: a one-line diagram, a site plan showing the Large Generating Facility and the ~~ICIF~~ Interconnection Customer's Interconnection Facilities, plan and elevation drawings showing the layout of the ~~ICIF~~ Interconnection Customer's Interconnection Facilities, a relay functional diagram, relaying AC and DC schematic wiring diagrams and relay settings for all facilities associated with the Interconnection Customer's step-up transformers, the facilities connecting the Large Generating Facility to the step-up transformers and the ~~ICIF~~ Interconnection Customer's Interconnection Facilities, and the impedances (determined by factory tests) for the associated step-up transformers and the ~~Large Electric~~ Generating Facility Units. The Interconnection Customer shall provide ~~Transmission Provider~~ the Participating TO and the CAISO specifications for the excitation system, automatic voltage regulator, Large Generating Facility control and protection settings, transformer tap settings, and communications, if

applicable. Any deviations from the relay settings, machine specifications, and other specifications originally submitted by the Interconnection Customer shall be assessed by the Participating TO and the CAISO pursuant to the appropriate provisions of this LGIA and the LGIP.

5.10.4 Interconnection Customer to Meet Requirements of the Participating TO's Interconnection Handbook. The Interconnection Customer shall comply with the Participating TO's Interconnection Handbook.

- 5.11 ~~Transmission Provider~~ Participating TO's Interconnection Facilities Construction.** ~~Transmission Provider~~ The Participating TO's Interconnection Facilities shall be designed and constructed in accordance with Good Utility Practice. Upon request, within one hundred twenty (120) Calendar Days after the Commercial Operation Date, unless the ~~Parties~~ Participating TO and Interconnection Customer agree on another mutually acceptable deadline, ~~Transmission Provider~~ the Participating TO shall deliver to the Interconnection Customer and the CAISO the following "as-built" drawings, information and documents for ~~Transmission Provider~~ the Participating TO's Interconnection Facilities [include appropriate drawings and relay diagrams].

~~Transmission Provider~~ The Participating TO will obtain control ~~of Transmission Provider~~ for operating and maintenance purposes of the Participating TO's Interconnection Facilities and Stand Alone Network Upgrades upon completion of such facilities. Pursuant to Article 5.2, the CAISO will obtain Operational Control of the Stand Alone Network Upgrades prior to the Commercial Operation Date.

- 5.12 Access Rights.** Upon reasonable notice and supervision by a Party, and subject to any required or necessary regulatory approvals, a Party ("Granting Party") shall furnish at no cost to the other Party ("Access Party") any rights of use, licenses, rights of way and easements with respect to lands owned or controlled by the Granting Party, its agents (if allowed under the applicable agency agreement), or any Affiliate, that are necessary to enable the Access Party to obtain ingress and egress to construct, operate, maintain, repair, test (or witness testing), inspect, replace or remove facilities and equipment to: (i) interconnect the Large Generating Facility with the Participating TO's Transmission System; (ii) operate and maintain the Large Generating Facility, the Interconnection Facilities and the Participating TO's Transmission System; and (iii) disconnect or remove the Access Party's facilities and equipment upon termination of this LGIA. In exercising such licenses, rights of way and easements, the Access Party shall not unreasonably disrupt or interfere with normal operation of the Granting Party's business and shall adhere to the safety rules and procedures established in advance, as may be changed from time to time, by the Granting Party and provided to the Access Party.

- 5.13 Lands of Other Property Owners.** If any part of ~~Transmission Provider or Transmission Owner~~ the Participating TO's Interconnection Facilities and/or Network

Upgrades ~~is~~are to be installed on property owned by persons other than the Interconnection Customer or ~~Transmission Provider or Transmission Owner~~, ~~Transmission Provider or Transmission Owner~~ Participating TO, the Participating TO shall at the Interconnection Customer's expense use efforts, similar in nature and extent to those that it typically undertakes on its own behalf or on behalf of its Affiliates, including use of its eminent domain authority, and to the extent consistent with state law, to procure from such persons any rights of use, licenses, rights of way and easements that are necessary to construct, operate, maintain, test, inspect, replace or remove ~~Transmission Provider or Transmission Owner~~ the Participating TO's Interconnection Facilities and/or Network Upgrades upon such property.

- 5.14 Permits.** ~~Transmission Provider or Transmission Owner~~ Participating TO and Interconnection Customer shall cooperate with each other in good faith in obtaining all permits, licenses, and ~~authorizations~~ authorization that are necessary to accomplish the interconnection in compliance with Applicable Laws and Regulations. With respect to this paragraph, ~~Transmission Provider or Transmission Owner~~ the Participating TO shall provide permitting assistance to the Interconnection Customer comparable to that provided to ~~Transmission Provider~~ the Participating TO's own, or an Affiliate's generation.
- 5.15 Early Construction of Base Case Facilities.** The Interconnection Customer may request ~~Transmission Provider~~ the Participating TO to construct, and ~~Transmission Provider~~ the Participating TO shall construct, using Reasonable Efforts to accommodate Interconnection Customer's In-Service Date, all or any portion of any Network Upgrades required for Interconnection Customer to be interconnected to the Participating TO's Transmission System which are included in the Base Case of the ~~Facilities Study for~~ Interconnection Studies for the Interconnection Customer, and which also are required to be constructed for another ~~Interconnection Customer~~ interconnection customer, but where such construction is not scheduled to be completed in time to achieve Interconnection Customer's In-Service Date.
- 5.16 Suspension.** The Interconnection Customer reserves the right, upon written notice to ~~Transmission Provider~~ the Participating TO and the CAISO, to suspend at any time all work ~~by Transmission Provider~~ associated with the construction and installation of ~~Transmission Provider~~ the Participating TO's Interconnection Facilities, Network Upgrades, and/or ~~Network~~ Distribution Upgrades required under this LGIA, other than Network Upgrades identified in the Phase II Interconnection Study as common to multiple Generating Facilities, with the condition that ~~Transmission System~~ the Participating TO's electrical system and the CAISO Controlled Grid shall be left in a safe and reliable condition in accordance with Good Utility Practice and ~~Transmission Provider~~ the Participating TO's safety and reliability criteria and the CAISO's Applicable Reliability Standards. In such event, the Interconnection Customer shall be responsible for all reasonable and necessary costs which ~~Transmission Provider~~ the Participating TO (i) has incurred pursuant to this LGIA prior to the suspension and (ii) incurs in suspending such

work, including any costs incurred to perform such work as may be necessary to ensure the safety of persons and property and the integrity of the ~~Transmission System~~ Participating TO's electric system during such suspension and, if applicable, any costs incurred in connection with the cancellation or suspension of material, equipment and labor contracts which ~~Transmission Provider~~ the Participating TO cannot reasonably avoid; provided, however, that prior to canceling or suspending any such material, equipment or labor contract, ~~Transmission Provider~~ the Participating TO shall obtain Interconnection Customer's authorization to do so.

~~Transmission Provider~~ The Participating TO shall invoice the Interconnection Customer for such costs pursuant to Article 12 and shall use due diligence to minimize its costs. In the event Interconnection Customer suspends work ~~by Transmission Provider~~ required under this LGIA pursuant to this Article 5.16, and has not requested ~~Transmission Provider~~ the Participating TO to recommence the work or has not itself recommenced work required under this LGIA ~~on or before the expiration of three (3) years following commencement of such suspension~~ in time to ensure that the new projected Commercial Operation Date for the full Generating Facility Capacity of the Large Generating Facility is no more than three (3) years from the Commercial Operation Date identified in Appendix B hereto, this LGIA shall be deemed terminated. ~~The three-year~~ and the Interconnection Customer's responsibility for costs will be determined in accordance with Section 2.4 of this LGIA. The suspension period shall begin on the date the suspension is requested, or the date of the written notice to ~~Transmission Provider~~ the Participating TO and the CAISO, if no effective date is specified.

5.17 Taxes.

5.17.1 Interconnection Customer Payments Not Taxable. The Parties intend that all payments or property transfers made by the Interconnection Customer to ~~Transmission Provider~~ the Participating TO for the installation of ~~Transmission Provider~~ the Participating TO's Interconnection Facilities and the Network Upgrades shall be non-taxable, either as contributions to capital, or as ~~an~~ a refundable advance, in accordance with the Internal Revenue Code and any applicable state income tax laws and shall not be taxable as contributions in aid of construction or otherwise under the Internal Revenue Code and any applicable state income tax laws.

5.17.2 Representations ~~and~~ And Covenants. In accordance with IRS Notice 2001-82 and IRS Notice 88-129, the Interconnection Customer represents and covenants that (i) ownership of the electricity generated at the Large Generating Facility will pass to another party prior to the transmission of the electricity on the ~~Transmission System~~ CAISO Controlled Grid, (ii) for income tax purposes, the amount of any payments and the cost of any property transferred to ~~Transmission Provider for Transmission Provider~~ the Participating TO for the Participating TO's Interconnection Facilities will be

capitalized by the Interconnection Customer as an intangible asset and recovered using the straight-line method over a useful life of twenty (20) years, and (iii) any portion of ~~Transmission Provider~~the Participating TO's Interconnection Facilities that is a "dual-use intertie," within the meaning of IRS Notice 88-129, is reasonably expected to carry only a de minimis amount of electricity in the direction of the Large Generating Facility. For this purpose, "de minimis amount" means no more than 5 percent of the total power flows in both directions, calculated in accordance with the "5 percent test" set forth in IRS Notice 88-129. This is not intended to be an exclusive list of the relevant conditions that must be met to conform to IRS requirements for non-taxable treatment.

At ~~Transmission Provider~~the Participating TO's request, the Interconnection Customer shall provide ~~Transmission Provider~~the Participating TO with a report from an independent engineer confirming its representation in clause (iii), above. ~~Transmission Provider~~The Participating TO represents and covenants that the cost of ~~Transmission Provider~~the Participating TO's Interconnection Facilities paid for by the Interconnection Customer without the possibility of refund or credit will have no net effect on the base upon which rates are determined.

5.17.3 Indemnification for the Cost ~~Consequences~~Consequence of Current Tax Liability Imposed Upon the ~~Transmission Provider~~Participating TO.

Notwithstanding Article 5.17.1, the Interconnection Customer shall protect, indemnify and hold harmless ~~Transmission Provider~~the Participating TO from the cost consequences of any current tax liability imposed against ~~Transmission Provider~~the Participating TO as the result of payments or property transfers made by the Interconnection Customer to ~~Transmission Provider~~the Participating TO under this LGIA for Interconnection Facilities, as well as any interest and penalties, other than interest and penalties attributable to any delay caused by ~~Transmission Provider~~the Participating TO.

~~Transmission Provider~~The Participating TO shall not include a gross-up for the cost consequences of any current tax liability in the amounts it charges the Interconnection Customer under this LGIA unless (i) ~~Transmission Provider~~the Participating TO has determined, in good faith, that the payments or property transfers made by the Interconnection Customer to ~~Transmission Provider~~the Participating TO should be reported as income subject to taxation or (ii) any Governmental Authority directs ~~Transmission Provider~~the Participating TO to report payments or property as income subject to taxation; provided, however, that ~~Transmission Provider~~the Participating TO may require the Interconnection Customer to provide security for Interconnection Facilities, in a form reasonably acceptable to ~~Transmission Provider~~the Participating TO (such as a parental guarantee or a letter of credit), in an amount equal to the cost consequences of any

current tax liability under this Article 5.17. The Interconnection Customer shall reimburse ~~Transmission Provider~~the Participating TO for such costs on a fully grossed-up basis, in accordance with Article 5.17.4, within thirty (30) Calendar Days of receiving written notification from ~~Transmission Provider~~the Participating TO of the amount due, including detail about how the amount was calculated.

The indemnification obligation shall terminate at the earlier of (1) the expiration of the ten year testing period and the applicable statute of limitation, as it may be extended by ~~Transmission Provider~~the Participating TO upon request of the IRS, to keep these years open for audit or adjustment, or (2) the occurrence of a subsequent taxable event and the payment of any related indemnification obligations as contemplated by this Article 5.17.

5.17.4 Tax Gross-Up Amount. The Interconnection Customer's liability for the cost consequences of any current tax liability under this Article 5.17 shall be calculated on a fully grossed-up basis. Except as may otherwise be agreed to by the parties, this means that the Interconnection Customer will pay ~~Transmission Provider~~the Participating TO, in addition to the amount paid for the Interconnection Facilities and Network Upgrades, an amount equal to (1) the current taxes imposed on ~~Transmission Provider~~ ("the Participating TO ("Current Taxes")) on the excess of (a) the gross income realized by ~~Transmission Provider~~the Participating TO as a result of payments or property transfers made by the Interconnection Customer to ~~Transmission Provider~~the Participating TO under this LGIA (without regard to any payments under this Article 5.17) (the "Gross Income Amount") over (b) the present value of future tax deductions for depreciation that will be available as a result of such payments or property transfers (the "Present Value Depreciation Amount"), plus (2) an additional amount sufficient to permit ~~Transmission Provider~~the Participating TO to receive and retain, after the payment of all Current Taxes, an amount equal to the net amount described in clause (1).

For this purpose, (i) Current Taxes shall be computed based on ~~Transmission Provider~~the Participating TO's composite federal and state tax rates at the time the payments or property transfers are received and ~~Transmission Provider~~the Participating TO will be treated as being subject to tax at the highest marginal rates in effect at that time (the "Current Tax Rate"), and (ii) the Present Value Depreciation Amount shall be computed by discounting ~~Transmission Provider~~the Participating TO's anticipated tax depreciation deductions as a result of such payments or property transfers by ~~Transmission Provider~~the Participating TO's current weighted average cost of capital. Thus, the formula for calculating the Interconnection Customer's liability to ~~Transmission Owner~~the Participating TO pursuant to this Article 5.17.4 can be expressed as follows: (Current

Tax Rate x (Gross Income Amount – Present Value of Tax Depreciation))/(1-Current Tax Rate). Interconnection Customer's estimated tax liability in the event taxes are imposed shall be stated in Appendix A, Interconnection Facilities, Network Upgrades and Distribution Upgrades.

5.17.5 Private Letter Ruling or Change or Clarification of Law. At the Interconnection Customer's request and expense, ~~Transmission Provider~~the Participating TO shall file with the IRS a request for a private letter ruling as to whether any property transferred or sums paid, or to be paid, by the Interconnection Customer to ~~Transmission Provider~~the Participating TO under this LGIA are subject to federal income taxation. The Interconnection Customer will prepare the initial draft of the request for a private letter ruling, and will certify under penalties of perjury that all facts represented in such request are true and accurate to the best of the Interconnection Customer's knowledge. ~~Transmission Provider~~The Participating TO and Interconnection Customer shall cooperate in good faith with respect to the submission of such request, provided, however, the Interconnection Customer and the Participating TO explicitly acknowledge (and nothing herein is intended to alter) Participating TO's obligation under law to certify that the facts presented in the ruling request are true, correct and complete.

~~Transmission Provider~~The Participating TO shall keep the Interconnection Customer fully informed of the status of such request for a private letter ruling and shall execute either a privacy act waiver or a limited power of attorney, in a form acceptable to the IRS, that authorizes the Interconnection Customer to participate in all discussions with the IRS regarding such request for a private letter ruling. ~~Transmission Provider~~The Participating TO shall allow the Interconnection Customer to attend all meetings with IRS officials about the request and shall permit the Interconnection Customer to prepare the initial drafts of any follow-up letters in connection with the request.

5.17.6 Subsequent Taxable Events. If, within 10 years from the date on which the relevant ~~Transmission Provider~~Participating TO's Interconnection Facilities are placed in service, (i) the Interconnection Customer Breaches the covenants contained in Article 5.17.2, (ii) a "disqualification event" occurs within the meaning of IRS Notice 88-129, or (iii) this LGIA terminates and ~~Transmission Provider~~the Participating TO retains ownership of the Interconnection Facilities and Network Upgrades, the Interconnection Customer shall pay a tax gross-up for the cost consequences of any current tax liability imposed on ~~Transmission Provider~~the Participating TO, calculated using the methodology described in Article 5.17.4 and in accordance with IRS Notice 90-60.

5.17.7 Contests. In the event any Governmental Authority determines that ~~Transmission Provider~~the Participating TO's receipt of payments or property constitutes income that is subject to taxation, ~~Transmission Provider~~the Participating TO shall notify the Interconnection Customer, in writing, within thirty (30) Calendar Days of receiving notification of such determination by a Governmental Authority. Upon the timely written request by the Interconnection Customer and at the Interconnection Customer's sole expense, ~~Transmission Provider~~the Participating TO may appeal, protest, seek abatement of, or otherwise oppose such determination. Upon the Interconnection Customer's written request and sole expense, ~~Transmission Provider~~the Participating TO may file a claim for refund with respect to any taxes paid under this Article 5.17, whether or not it has received such a determination. ~~Transmission Provider reserves~~The Participating TO reserve the right to make all decisions with regard to the prosecution of such appeal, protest, abatement or other contest, including the selection of counsel and compromise or settlement of the claim, but ~~Transmission Provider~~the Participating TO shall keep the Interconnection Customer informed, shall consider in good faith suggestions from the Interconnection Customer about the conduct of the contest, and shall reasonably permit the Interconnection Customer or an Interconnection Customer representative to attend contest proceedings.

The Interconnection Customer shall pay to ~~Transmission Provider~~the Participating TO on a periodic basis, as invoiced by ~~Transmission Provider~~, ~~Transmission Provider~~the Participating TO, the Participating TO's documented reasonable costs of prosecuting such appeal, protest, abatement or other contest—, including any costs associated with obtaining the opinion of independent tax counsel described in this Article 5.17.7. The Participating TO may abandon any contest if the Interconnection Customer fails to provide payment to the Participating TO within thirty (30) Calendar Days of receiving such invoice.

At any time during the contest, ~~Transmission Provider~~the Participating TO may agree to a settlement either with the Interconnection Customer's consent or, if such consent is refused, after obtaining written advice from independent nationally-recognized tax counsel, selected by ~~Transmission Provider~~the Participating TO, but reasonably acceptable to the Interconnection Customer, that the proposed settlement represents a reasonable settlement given the hazards of litigation. The Interconnection Customer's obligation shall be based on the amount of the settlement agreed to by the Interconnection Customer, or if a higher amount, so much of the settlement that is supported by the written advice from nationally-recognized tax counsel selected under the terms of the preceding ~~sentence~~paragraph. The settlement amount shall be calculated on a fully grossed-up basis to cover any related cost consequences of the current tax liability. ~~Any settlement~~ The Participating TO may also settle any

tax controversy without receiving the Interconnection Customer's consent or any such written advice; however, any such settlement will relieve the Interconnection Customer from any obligation to indemnify ~~Transmission Provider~~the Participating TO for the tax at issue in the contest (unless the failure to obtain written advice is attributable to the Interconnection Customer's unreasonable refusal to the appointment of independent tax counsel).

5.17.8 Refund. In the event that (a) a private letter ruling is issued to ~~Transmission Provider~~the Participating TO which holds that any amount paid or the value of any property transferred by the Interconnection Customer to ~~Transmission Provider~~the Participating TO under the terms of this LGIA is not subject to federal income taxation, (b) any legislative change or administrative announcement, notice, ruling or other determination makes it reasonably clear to ~~Transmission Provider~~the Participating TO in good faith that any amount paid or the value of any property transferred by the Interconnection Customer to ~~Transmission Provider~~the Participating TO under the terms of this LGIA is not taxable to ~~Transmission Provider~~the Participating TO, (c) any abatement, appeal, protest, or other contest results in a determination that any payments or transfers made by the Interconnection Customer to ~~Transmission Provider~~the Participating TO are not subject to federal income tax, or (d) if ~~Transmission Provider~~the Participating TO receives a refund from any taxing authority for any overpayment of tax attributable to any payment or property transfer made by the Interconnection Customer to ~~Transmission Provider~~the Participating TO pursuant to this LGIA, ~~Transmission Provider~~the Participating TO shall promptly refund to the Interconnection Customer the following:

(i) any payment made by Interconnection Customer under this Article 5.17 for taxes that is attributable to the amount determined to be non-taxable, together with interest thereon,

(ii) interest on any ~~amount~~amounts paid by the Interconnection Customer to ~~Transmission Provider~~the Participating TO for such taxes which ~~Transmission Provider~~the Participating TO did not submit to the taxing authority, calculated in accordance with the methodology set forth in FERC's regulations at 18 ~~CFR~~C.F.R. §35.19a(a)(2)(iii) from the date payment was made by the Interconnection Customer to the date ~~Transmission Provider~~the Participating TO refunds such payment to the Interconnection Customer, and

(iii) with respect to any such taxes paid by ~~Transmission Provider~~the Participating TO, any refund or credit ~~Transmission Provider~~the Participating TO receives or to which it may be entitled from any Governmental Authority, interest (or that portion thereof attributable to the payment described in clause (i), above) owed to ~~Transmission~~

~~Provider~~the Participating TO for such overpayment of taxes (including any reduction in interest otherwise payable by ~~Transmission Provider~~the Participating TO to any Governmental Authority resulting from an offset or credit); provided, however, that ~~Transmission Provider~~the Participating TO will remit such amount promptly to the Interconnection Customer only after and to the extent that ~~Transmission Provider~~the Participating TO has received a tax refund, credit or offset from any Governmental Authority for any applicable overpayment of income tax related to ~~Transmission Provider~~the Participating TO's Interconnection Facilities.

The intent of this provision is to leave the Parties, to the extent practicable, in the event that no taxes are due with respect to any payment for Interconnection Facilities and Network Upgrades hereunder, in the same position they would have been in had no such tax payments been made.

5.17.9 Taxes Other Than Income Taxes. Upon the timely request by the Interconnection Customer, and at the Interconnection Customer's sole expense, ~~Transmission Provider~~the CAISO or Participating TO may appeal, protest, seek abatement of, or otherwise contest any tax (other than federal or state income tax) asserted or assessed against ~~Transmission Provider~~the CAISO or Participating TO for which the Interconnection Customer may be required to reimburse ~~Transmission Provider~~the CAISO or Participating TO under the terms of this LGIA. The Interconnection Customer shall pay to ~~Transmission Provider~~the Participating TO on a periodic basis, as invoiced by ~~Transmission Provider~~the Participating TO, the Participating TO's documented reasonable costs of prosecuting such appeal, protest, abatement, or other contest. The Interconnection Customer ~~and Transmission Provider~~, the CAISO, and the Participating TO shall cooperate in good faith with respect to any such contest. Unless the payment of such taxes is a prerequisite to an appeal or abatement or cannot be deferred, no amount shall be payable by the Interconnection Customer to ~~Transmission Provider~~the CAISO or Participating TO for such taxes until they are assessed by a final, non-appealable order by any court or agency of competent jurisdiction. In the event that a tax payment is withheld and ultimately due and payable after appeal, the Interconnection Customer will be responsible for all taxes, interest and penalties, other than penalties attributable to any delay caused by ~~Transmission Provider~~the Participating TO.

~~**5.17.10 Transmission Owners Who Are Not Transmission Providers.** If Transmission Provider is not the same entity as the Transmission Owner, then (i) all references in this Article 5.17 to Transmission Provider shall be deemed also to refer to and to include the Transmission Owner, as appropriate, and (ii) this LGIA shall not become effective until such Transmission Owner shall have agreed in writing to assume all of the duties and obligations of Transmission Provider under this Article 5.17 of this LGIA.~~

5.18 Tax Status. Each Party shall cooperate with the ~~other~~others to maintain the other ~~Party's~~Parties' tax status. Nothing in this LGIA is intended to adversely affect ~~any Transmission Provider~~the CAISO's or any Participating TO's tax exempt status with respect to the issuance of bonds including, but not limited to, Local Furnishing Bonds.

5.19 Modification.

5.19.1 General. ~~Either Party~~The Interconnection Customer or the Participating TO may undertake modifications to its facilities, subject to the provisions of this LGIA and the CAISO Tariff. If a Party plans to undertake a modification that reasonably may be expected to affect the other ~~Party's~~Parties' facilities, that Party shall provide to the other ~~Party~~Parties sufficient information regarding such modification so that the other ~~Party~~Parties may evaluate the potential impact of such modification prior to commencement of the work. Such information shall be deemed to be confidential hereunder and shall include information concerning the timing of such modifications and whether such modifications are expected to interrupt the flow of electricity from the Large Generating Facility. The Party desiring to perform such work shall provide the relevant drawings, plans, and specifications to the other ~~Party~~Parties at least ninety (90) Calendar Days in advance of the commencement of the work or such shorter period upon which the Parties may agree, which agreement shall not unreasonably be withheld, conditioned or delayed.

In the case of Large Generating Facility modifications that do not require the Interconnection Customer to submit an Interconnection Request, ~~Transmission Provider~~the CAISO or Participating TO shall provide, within thirty (30) Calendar Days (or such other time as the Parties may agree), an estimate of any additional modifications to the ~~Transmission System, Transmission Provider~~CAISO Controlled Grid, Participating TO's Interconnection Facilities ~~or~~, Network Upgrades or Distribution Upgrades necessitated by such Interconnection Customer modification and a good faith estimate of the costs thereof. The Participating TO and the CAISO shall determine if a Large Generating Facility modification is a Material Modification in accordance with the LGIP.

5.19.2 Standards. Any additions, modifications, or replacements made to a Party's facilities shall be designed, constructed and operated in accordance with this LGIA, ~~Applicable Reliability Standards~~, and Good Utility Practice.

5.19.3 Modification Costs. The Interconnection Customer shall not be directly assigned ~~for~~ the costs of any additions, modifications, or replacements that ~~Transmission Provider~~the Participating TO makes to ~~Transmission Provider~~the Participating TO's Interconnection Facilities or the Participating TO's

Transmission System to facilitate the interconnection of a third party to ~~Transmission Provider~~the Participating TO's Interconnection Facilities or the Participating TO's Transmission System, or to provide transmission service to a third party under ~~Transmission Provider's~~the CAISO Tariff. The Interconnection Customer shall be responsible for the costs of any additions, modifications, or replacements to ~~Interconnection Customer's~~the Interconnection Facilities that may be necessary to maintain or upgrade such ~~Interconnection Customer's~~ Interconnection Facilities consistent with Applicable Laws and Regulations, Applicable Reliability Standards or Good Utility Practice.

~~Article 6. Testing and Inspection~~

ARTICLE 6. TESTING AND INSPECTION

- 6.1 Pre-Commercial Operation Date Testing and Modifications.** Prior to the Commercial Operation Date, ~~Transmission Provider~~the Participating TO shall test ~~Transmission Provider~~the Participating TO's Interconnection Facilities ~~and~~ Network Upgrades, and Distribution Upgrades and the Interconnection Customer shall test the Large Generating Facility and the Interconnection Customer's Interconnection Facilities to ensure their safe and reliable operation. Similar testing may be required after initial operation. Each Party shall make any modifications to its facilities that are found to be necessary as a result of such testing. The Interconnection Customer shall bear the cost of all such testing and modifications. The Interconnection Customer shall not commence initial parallel operation of an Electric Generating Unit with the Participating TO's Transmission System until the Participating TO provides prior written approval, which approval shall not be unreasonably withheld, for operation of such Electric Generating Unit. The Interconnection Customer shall generate test energy at the Large Generating Facility only if it has arranged for the delivery of such test energy.
- 6.2 Post-Commercial Operation Date Testing and Modifications.** Each Party shall at its own expense perform routine inspection and testing of its facilities and equipment in accordance with Good Utility Practice as may be necessary to ensure the continued interconnection of the Large Generating Facility with the Participating TO's Transmission System in a safe and reliable manner. Each Party shall have the right, upon advance written notice, to require reasonable additional testing of the other Party's facilities, at the requesting Party's expense, as may be in accordance with Good Utility Practice.
- 6.3 Right to Observe Testing.** Each Party shall notify the other ~~Party~~Parties at least fourteen (14) Calendar Days in advance of its performance of tests of its Interconnection Facilities or Generating Facility. The other ~~Party has~~Parties have the right, at ~~its~~their own expense, to observe such testing.
- 6.4 Right to Inspect.** Each Party shall have the right, but shall have no obligation to: (i) observe ~~the other~~another Party's tests and/or inspection of any of its System

Protection Facilities and other protective equipment, including Power System Stabilizers; (ii) review the settings of ~~the other~~another Party's System Protection Facilities and other protective equipment; and (iii) review ~~the other~~another Party's maintenance records relative to the Interconnection Facilities, the System Protection Facilities and other protective equipment. A Party may exercise these rights from time to time as it deems necessary upon reasonable notice to the other Party. The exercise or non-exercise by a Party of any such rights shall not be construed as an endorsement or confirmation of any element or condition of the Interconnection Facilities or the System Protection Facilities or other protective equipment or the operation thereof, or as a warranty as to the fitness, safety, desirability, or reliability of same. Any information that a Party obtains through the exercise of any of its rights under this Article 6.4 shall be deemed to be Confidential Information and treated pursuant to Article 22 of this LGIA.

~~Article 7. Metering~~

ARTICLE 7. METERING

- 7.1 General.** Each Party shall comply with any Applicable Reliability Standards and the Applicable Reliability Council requirements. The Interconnection Customer and CAISO shall comply with the provisions of the CAISO Tariff regarding metering, including Section 10 of the CAISO Tariff. Unless otherwise agreed by the ~~Parties, Transmission Provider shall~~Participating TO and the Interconnection Customer, the Participating TO may install additional Metering Equipment at the Point of Interconnection prior to any operation of ~~the Large~~any Electric Generating Facility ~~Unit~~ and shall own, operate, test and maintain such Metering Equipment. Power flows to and from the Large Generating Facility shall be measured at or, at ~~Transmission Provider's option~~the CAISO's or Participating TO's option for its respective Metering Equipment, compensated to, the Point of Interconnection. ~~Transmission Provider~~The CAISO shall provide metering quantities, ~~in analog and/or digital form,~~ to the Interconnection Customer upon request. ~~in accordance with the CAISO Tariff by directly polling the CAISO's meter data acquisition system.~~ The Interconnection Customer shall bear all reasonable documented costs associated with the purchase, installation, operation, testing and maintenance of the Metering Equipment.
- 7.2 Check Meters.** The Interconnection Customer, at its option and expense, may install and operate, on its premises and on its side of the Point of Interconnection, one or more check meters to check ~~Transmission Provider~~the CAISO-pollled meters or the Participating TO's meters. Such check meters shall be for check purposes only and shall not be used for the measurement of power flows for purposes of this LGIA, except ~~as provided in Article 7.4 below~~in the case that no other means are available on a temporary basis at the option of the CAISO or the Participating TO. The check meters shall be subject at all reasonable times to inspection and examination by ~~Transmission Provider or its designee~~the CAISO or Participating TO or their designees. The installation, operation and maintenance

thereof shall be performed entirely by the Interconnection Customer in accordance with Good Utility Practice.

~~7.3 — **Standards.** Transmission Provider shall install, calibrate, and test revenue quality Metering Equipment in accordance with applicable ANSI standards.~~

7.3 Participating TO Retail Metering. The Participating TO may install retail revenue quality meters and associated equipment, pursuant to the Participating TO's applicable retail tariffs.

~~7.4 — **Testing of Metering Equipment.** Transmission Provider shall inspect and test all Transmission Provider-owned Metering Equipment upon installation and at least once every two (2) years thereafter. If requested to do so by Interconnection Customer, Transmission Provider shall, at Interconnection Customer's expense, inspect or test Metering Equipment more frequently than every two (2) years. Transmission Provider shall give reasonable notice of the time when any inspection or test shall take place, and Interconnection Customer may have representatives present at the test or inspection. If at any time Metering Equipment is found to be inaccurate or defective, it shall be adjusted, repaired or replaced at Interconnection Customer's expense, in order to provide accurate metering, unless the inaccuracy or defect is due to Transmission Provider's failure to maintain, then Transmission Provider shall pay. If Metering Equipment fails to register, or if the measurement made by Metering Equipment during a test varies by more than two percent from the measurement made by the standard meter used in the test, Transmission Provider shall adjust the measurements by correcting all measurements for the period during which Metering Equipment was in error by using Interconnection Customer's check meters, if installed. If no such check meters are installed or if the period cannot be reasonably ascertained, the adjustment shall be for the period immediately preceding the test of the Metering Equipment equal to one-half the time from the date of the last previous test of the Metering Equipment.~~

~~7.5 — **Metering Data.** At Interconnection Customer's expense, the metered data shall be telemetered to one or more locations designated by Transmission Provider and one or more locations designated by Interconnection Customer. Such telemetered data shall be used, under normal operating conditions, as the official measurement of the amount of energy delivered from the Large Generating Facility to the Point of Interconnection.~~

~~Article 8. — **Communications**~~

ARTICLE 8. COMMUNICATIONS

8.1 Interconnection Customer Obligations. The Interconnection Customer shall maintain satisfactory operating communications with ~~Transmission Provider's Transmission System~~ the CAISO in accordance with the provisions of the CAISO Tariff and with the Participating TO's dispatcher or representative designated by ~~Transmission Provider.~~ the Participating TO. The Interconnection Customer shall provide standard voice line, dedicated voice line and facsimile communications at its Large Generating Facility control room or central dispatch facility through use of either the public telephone system, or a voice communications system that does not rely on the public telephone system. The Interconnection Customer shall also provide the dedicated data circuit(s) necessary to provide Interconnection Customer data to ~~Transmission Provider~~ the CAISO and Participating TO as set forth in Appendix D, Security Arrangements Details. The data

circuit(s) shall extend from the Large Generating Facility to the location(s) specified by ~~Transmission Provider~~the CAISO and Participating TO. Any required maintenance of such communications equipment shall be performed by the Interconnection Customer. Operational communications shall be activated and maintained under, but not be limited to, the following events: system paralleling or separation, scheduled and unscheduled shutdowns, equipment clearances, and hourly and daily load data.

- 8.2 Remote Terminal Unit.** Prior to the Initial Synchronization Date of ~~the Large~~each Electric Generating ~~Facility~~Unit, a Remote Terminal Unit, or equivalent data collection and transfer equipment acceptable to the Parties, shall be installed by the Interconnection Customer, or by ~~Transmission Provider at~~the Participating TO at the Interconnection Customer's expense, to gather accumulated and instantaneous data to be telemetered to the location(s) designated by ~~Transmission Provider~~the CAISO and by the Participating TO through use of a dedicated point-to-point data circuit(s) as indicated in Article 8.1. ~~The~~

Telemetry to the CAISO shall be provided in accordance with the CAISO's technical standards for direct telemetry. For telemetry to the Participating TO, the communication protocol for the data circuit(s) shall be specified by ~~Transmission Provider~~the Participating TO. Instantaneous bi-directional ~~analog~~-real power and reactive power flow and any other required information must be telemetered directly to the location(s) specified by ~~Transmission Provider~~the Participating TO.

Each Party will promptly advise the other ~~Party~~Parties if it detects or otherwise learns of any metering, telemetry or communications equipment errors or malfunctions that require the attention and/or correction by ~~the other~~another Party. The Party owning such equipment shall correct such error or malfunction as soon as reasonably feasible.

- 8.3 No Annexation.** Any and all equipment placed on the premises of a Party shall be and remain the property of the Party providing such equipment regardless of the mode and manner of annexation or attachment to real property, unless otherwise mutually agreed by the Parties.

~~Article 9. Operations~~

ARTICLE 9. OPERATIONS

- 9.1 General.** Each Party shall comply with Applicable Reliability Standards and the Applicable Reliability Council requirements. Each Party shall provide to the other Party all information that may reasonably be required by the other Party to comply with Applicable Laws and Regulations and Applicable Reliability Standards.

- 9.2 **~~Control~~Balancing Authority Area Notification.** At least three months before Initial Synchronization Date, the Interconnection Customer shall notify ~~Transmission Provider~~the CAISO and Participating TO in writing of the ~~Control~~Balancing Authority Area in which the Large Generating Facility ~~will~~intends to be located. If the Interconnection Customer ~~elects~~intends to locate the Large Generating Facility in a ~~Control~~Balancing Authority Area other than the ~~Control Area in which~~Balancing Authority Area within whose electrically metered boundaries the Large Generating Facility is ~~physically~~ located, and if permitted to do so by the relevant transmission tariffs, all necessary arrangements, including but not limited to those set forth in Article 7 and Article 8 of this LGIA, and remote ~~Control~~Balancing Authority Area generator interchange agreements, if applicable, and the appropriate measures under such agreements, shall be executed and implemented prior to the placement of the Large Generating Facility in the other ~~Control~~Balancing Authority Area.
- 9.3 **~~Transmission Provider~~CAISO and Participating TO Obligations.** ~~Transmission Provider shall cause the Transmission System and Transmission Provider~~The CAISO and Participating TO shall cause the Participating TO's Transmission System to be operated and controlled in a safe and reliable manner and in accordance with this LGIA. The Participating TO at the Interconnection Customer's expense shall cause the Participating TO's Interconnection Facilities to be operated, maintained and controlled in a safe and reliable manner and in accordance with this LGIA. ~~Transmission Provider~~The CAISO and Participating TO may provide operating instructions to the Interconnection Customer consistent with this LGIA and ~~Transmission Provider's~~Participating TO and CAISO operating protocols and procedures as they may change from time to time. ~~Transmission Provider~~The Participating TO and CAISO will consider changes to ~~its~~their operating protocols and procedures proposed by the Interconnection Customer.
- 9.4 **Interconnection Customer Obligations.** The Interconnection Customer shall at its own expense operate, maintain and control the Large Generating Facility and the Interconnection Customer's Interconnection Facilities in a safe and reliable manner and in accordance with this LGIA. The Interconnection Customer shall operate the Large Generating Facility and the Interconnection Customer's Interconnection Facilities in accordance with all applicable requirements of the ~~Control~~Balancing Authority Area of which it is part, ~~as~~including such requirements ~~are~~as set forth in Appendix C, Interconnection Details, of this LGIA. Appendix C, Interconnection Details, will be modified to reflect changes to the requirements as they may change from time to time. ~~Either~~A Party may request that ~~the~~ ~~other~~another Party provide copies of the requirements set forth in Appendix C, Interconnection Details, of this LGIA. The Interconnection Customer shall not commence Commercial Operation of an Electric Generating Unit with the Participating TO's Transmission System until the Participating TO provides prior written approval, which approval shall not be unreasonably withheld, for operation of such Electric Generating Unit.

9.5 Start-Up and Synchronization. Consistent with the Parties' mutually acceptable procedures, the Interconnection Customer is responsible for the proper synchronization of ~~the Large~~each Electric Generating Facility to ~~Transmission Provider's Transmission System.~~Unit to the CAISO Controlled Grid.

9.6 Reactive Power.

9.6.1 Power Factor Design Criteria. The Interconnection Customer shall design the Large Generating Facility to maintain a composite power delivery at continuous rated power output at the ~~Point of Interconnection~~terminals of the Electric Generating Unit at a power factor within the range of 0.95 leading to ~~0.95~~0.90 lagging, unless ~~Transmission Provider~~the CAISO has established different requirements that apply to all generators in the ~~Control~~Balancing Authority Area on a comparable basis. ~~The requirements of this paragraph shall not apply to~~Power factor design criteria for wind generators are provided in Appendix H of this LGIA.

9.6.2 Voltage Schedules. Once the Interconnection Customer has synchronized ~~the Large~~an Electric Generating Facility with the ~~Transmission System, Transmission Provider~~Unit with the CAISO Controlled Grid, the CAISO or Participating TO shall require the Interconnection Customer to ~~operate the Large~~maintain a voltage schedule by operating the Electric Generating Facility Unit to produce or absorb reactive power within the design limitations of the ~~Large~~Electric Generating Facility Unit set forth in Article 9.6.1 (Power Factor Design Criteria). ~~Transmission Provider~~CAISO's voltage schedules shall treat all sources of reactive power in the ~~Control~~Balancing Authority Area in an equitable and not unduly discriminatory manner. ~~Transmission Provider~~The Participating TO shall exercise Reasonable Efforts to provide the Interconnection Customer with such schedules at least one (1) day in advance, and the CAISO or Participating TO may make changes to such schedules as necessary to maintain the reliability of the ~~Transmission System.~~CAISO Controlled Grid or the Participating TO's electric system. The Interconnection Customer shall operate the ~~Large~~Electric Generating Facility Unit to maintain the specified output voltage or power factor ~~at the Point of Interconnection~~ within the design limitations of the ~~Large~~Electric Generating Facility Unit set forth in Article 9.6.1 (Power Factor Design Criteria). ~~If, and as may be required by the~~CAISO to operate the Electric Generating Unit at a specific voltage schedule within the design limitations set forth in Article 9.6.1. If the Interconnection Customer is unable to maintain the specified voltage or power factor, it shall promptly notify the ~~System Operator~~CAISO and the Participating TO.

9.6.2.1 Governors and Regulators. Whenever ~~the Large~~an Electric Generating Facility Unit is operated in parallel with the ~~Transmission System~~CAISO Controlled Grid and the speed governors (if installed

on the ~~generating unit~~ Electric Generating Unit pursuant to Good Utility Practice) and voltage regulators are capable of operation, the Interconnection Customer shall operate the ~~Large~~ Electric Generating Facility Unit with its speed governors and voltage regulators in automatic operation. If the ~~Large~~ Electric Generating Facility Unit's speed governors and voltage regulators are not capable of such automatic operation, the Interconnection Customer shall immediately notify ~~Transmission Provider's system operator, or its designated representative, and ensure that such Large Generating Facility~~ the CAISO and the Participating TO and ensure that the Electric Generating Unit operates as specified in Article 9.6.2 through manual operation and that such Electric Generating Unit's reactive power production or absorption (measured in MVARs) are within the design capability of the ~~Large~~ Electric Generating Facility's generating unit Unit(s) and steady state stability limits. The Interconnection Customer shall restore the speed governors and voltage regulators to automatic operation as soon as possible. If the Large Generating Facility's speed governors and voltage regulators are improperly tuned or malfunctioning, the CAISO shall have the right to order the reduction in output or disconnection of the Large Generating Facility if the reliability of the CAISO Controlled Grid would be adversely affected. The Interconnection Customer shall not cause its Large Generating Facility to disconnect automatically or instantaneously from the ~~Transmission System~~ CAISO Controlled Grid or trip any ~~generating unit~~ Electric Generating Unit comprising the Large Generating Facility for an under or over frequency condition unless the abnormal frequency condition persists for a time period beyond the limits set forth in ANSI/IEEE Standard C37.106, or such other standard as applied to other generators in the ~~Control~~ Balancing Authority Area on a comparable basis.

- 9.6.3 Payment for Reactive Power.** ~~Transmission Provider~~ CAISO is required to pay the Interconnection Customer for reactive power that Interconnection Customer provides or absorbs from ~~the Large~~ an Electric Generating Facility Unit when ~~Transmission Provider~~ the CAISO requests the Interconnection Customer to operate its ~~Large~~ Electric Generating Facility Unit outside the range specified in Article 9.6.1, provided that if ~~Transmission Provider~~ the CAISO pays ~~its own or affiliated~~ other generators for reactive power service within the specified range, it must also pay the Interconnection Customer. Payments shall be pursuant to Article 11.6 or such other agreement to which the ~~Parties~~ CAISO and Interconnection Customer have otherwise agreed.

9.7 Outages and Interruptions.

9.7.1 Outages.

9.7.1.1 Outage Authority and Coordination. Each Party may in accordance with Good Utility Practice in coordination with the other ~~Party~~Parties remove from service any of its respective Interconnection Facilities or Network Upgrades that may impact ~~the other~~another Party's facilities as necessary to perform maintenance or testing or to install or replace equipment. Absent an Emergency Condition, the Party scheduling a removal of such facility(ies) from service will use Reasonable Efforts to schedule such removal on a date and time mutually acceptable to ~~the~~all Parties. In all circumstances, any Party planning to remove such facility(ies) from service shall use Reasonable Efforts to minimize the effect on the other ~~Party~~Parties of such removal.

9.7.1.2 Outage Schedules. ~~Transmission Provider~~The CAISO shall post scheduled outages of ~~its transmission~~CAISO Controlled Grid facilities ~~on the OASIS.~~in accordance with the provisions of the CAISO Tariff. ~~The~~ Interconnection Customer shall submit its planned maintenance schedules for the Large Generating Facility to ~~Transmission Provider for a minimum of a rolling twenty-four month period.~~the CAISO in accordance with the CAISO Tariff. ~~The~~ Interconnection Customer shall update its planned maintenance schedules ~~as necessary.~~Transmission Providerin accordance with the CAISO Tariff. ~~The CAISO~~ may request ~~the~~ Interconnection Customer to reschedule its maintenance as necessary to maintain the reliability of the ~~Transmission System; provided, however, adequacy of generation supply shall not be a criterion in determining Transmission System reliability.~~ ~~Transmission Provider~~CAISO Controlled Grid in accordance with the CAISO Tariff. ~~Such planned maintenance schedules and updates and changes to such schedules shall be provided by the Interconnection Customer to the Participating TO concurrently with their submittal to the CAISO.~~ ~~The CAISO~~ shall compensate ~~the~~ Interconnection Customer for any additional direct costs that ~~the~~ Interconnection Customer incurs as a result of having to reschedule maintenance, ~~including any additional overtime, breaking of maintenance contracts or other costs above and beyond the cost Interconnection Customer would have incurred absent Transmission Provider's request to reschedule maintenance.~~in accordance with the CAISO Tariff. ~~The~~ Interconnection Customer will not be eligible to receive compensation, if during the twelve (12) months prior to the date of the scheduled maintenance, ~~the~~ Interconnection Customer had modified its schedule of maintenance activities.

9.7.1.3 Outage Restoration. If an outage on a Party's Interconnection Facilities or Network Upgrades adversely affects ~~the other~~another Party's operations or facilities, the Party that owns or controls the facility that is out of service shall use Reasonable Efforts to promptly restore such facility(ies) to a normal operating condition consistent with the nature of the outage. The Party that owns or controls the facility that is out of service shall provide the other ~~Party~~Parties, to the extent such information is known, information on the nature of the Emergency Condition, if the outage is caused by an Emergency Condition, an estimated time of restoration, and any corrective actions required. Initial verbal notice shall be followed up as soon as practicable with written notice explaining the nature of the outage, if requested by a Party, which may be provided by e-mail or facsimile.

9.7.2 Interruption of Service. If required by Good Utility Practice to do so, ~~Transmission Provider~~the CAISO or the Participating TO may require the Interconnection Customer to interrupt or reduce deliveries of electricity if such delivery of electricity could adversely affect ~~Transmission Provider~~the CAISO's or the Participating TO's ability to perform such activities as are necessary to safely and reliably operate and maintain the ~~Transmission System~~Participating TO's electric system or the CAISO Controlled Grid. The following provisions shall apply to any interruption or reduction permitted under this Article 9.7.2:

9.7.2.1 The interruption or reduction shall continue only for so long as reasonably necessary under Good Utility Practice;

9.7.2.2 Any such interruption or reduction shall be made on an equitable, non-discriminatory basis with respect to all generating facilities directly connected to the ~~Transmission System~~CAISO Controlled Grid, subject to any conditions specified in this LGIA;

9.7.2.3 When the interruption or reduction must be made under circumstances which do not allow for advance notice, ~~Transmission Provider~~the CAISO or Participating TO, as applicable, shall notify the Interconnection Customer by telephone as soon as practicable of the reasons for the curtailment, interruption, or reduction, and, if known, its expected duration. Telephone notification shall be followed by written notification, if requested by the Interconnection Customer, as soon as practicable;

9.7.2.4 Except during the existence of an Emergency Condition, ~~when the interruption or reduction can be scheduled without advance notice, Transmission Provider~~the CAISO or Participating TO shall notify the Interconnection Customer in advance regarding the timing of such ~~scheduling~~interruption or reduction and further notify the

Interconnection Customer of the expected duration. ~~Transmission Provider~~ The CAISO or Participating TO shall coordinate with the Interconnection Customer using Good Utility Practice to schedule the interruption or reduction during periods of least impact to the Interconnection Customer ~~and Transmission Provider~~, the CAISO, and the Participating TO;

9.7.2.5 The Parties shall cooperate and coordinate with each other to the extent necessary in order to restore the Large Generating Facility, Interconnection Facilities, ~~and the~~ Participating TO's Transmission System, and the CAISO Controlled Grid to their normal operating state, consistent with system conditions and Good Utility Practice.

9.7.3 Under-Frequency and Over Frequency Conditions. The ~~Transmission System~~ CAISO Controlled Grid is designed to automatically activate a load-shed program as required by Applicable Reliability Standards and the Applicable Reliability Council in the event of an under-frequency system disturbance. The Interconnection Customer shall implement under-frequency and over-frequency ~~relay~~ protection set points for the Large Generating Facility as required by Applicable Reliability Standards and the Applicable Reliability Council to ensure "ride through" ~~capability-of the Transmission System~~. Large Generating Facility response to frequency deviations of pre-determined magnitudes, both under-frequency and over-frequency deviations, shall be studied and coordinated with ~~Transmission Provider~~ the Participating TO and CAISO in accordance with Good Utility Practice. The term "ride through" as used herein shall mean the ability of a Generating Facility to stay connected to and synchronized with the ~~Transmission System~~ CAISO Controlled Grid during system disturbances within a range of under-frequency and over-frequency conditions, in accordance with Good Utility Practice.

9.7.4 System Protection and Other Control Requirements.

9.7.4.1 System Protection Facilities. The Interconnection Customer shall, at its expense, install, operate and maintain System Protection Facilities as a part of the Large Generating Facility or the Interconnection Customer's Interconnection Facilities. ~~Transmission Provider~~ The Participating TO shall install at the Interconnection Customer's expense any System Protection Facilities that may be required on ~~Transmission Provider~~ the Participating TO's Interconnection Facilities or the Participating TO's Transmission System as a result of the interconnection of the Large Generating Facility and the Interconnection Customer's Interconnection Facilities.

- 9.7.4.2 ~~Each Party~~ The Participating TO's and Interconnection Customer's protection facilities shall be designed and coordinated with other systems in accordance with Applicable Reliability Standards, Applicable Reliability Council criteria, and Good Utility Practice.
- 9.7.4.3 ~~Each Party~~ The Participating TO and Interconnection Customer shall each be responsible for protection of its facilities consistent with Good Utility Practice.
- 9.7.4.4 ~~Each Party~~ The Participating TO's and Interconnection Customer's protective relay design shall incorporate the necessary test switches to perform the tests required in Article 6. The required test switches will be placed such that they allow operation of lockout relays while preventing breaker failure schemes from operating and causing unnecessary breaker operations and/or the tripping of the Interconnection Customer's ~~units~~ Electric Generating Units.
- 9.7.4.5 ~~Each Party~~ The Participating TO and Interconnection Customer will test, operate and maintain System Protection Facilities in accordance with Good Utility Practice ~~and, if applicable, the requirements of the Participating TO's Interconnection Handbook.~~
- 9.7.4.6 Prior to the ~~In-Service Date~~ in-service date, and again prior to the Commercial Operation Date, ~~each Party or its agent~~ the Participating TO and Interconnection Customer or their agents shall perform a complete calibration test and functional trip test of the System Protection Facilities. At intervals suggested by Good Utility Practice, the standards and procedures of the Participating TO, including, if applicable, the requirements of the Participating TO's Interconnection Handbook, and following any apparent malfunction of the System Protection Facilities, each Party shall perform both calibration and functional trip tests of its System Protection Facilities. These tests do not require the tripping of any in-service generation unit. These tests do, however, require that all protective relays and lockout contacts be activated.
- 9.7.5 **Requirements for Protection.** In compliance with Good Utility Practice ~~and, if applicable, the requirements of the Participating TO's Interconnection Handbook,~~ the Interconnection Customer shall provide, install, own, and maintain relays, circuit breakers and all other devices necessary to remove any fault contribution of the Large Generating Facility to any short circuit occurring on the Participating TO's Transmission System not otherwise isolated by ~~Transmission Provider~~ the Participating TO's equipment, such that the removal of the fault

contribution shall be coordinated with the protective requirements of the Participating TO's Transmission System. Such protective equipment shall include, without limitation, a disconnecting device ~~or switch~~ with ~~load~~ fault current-interrupting capability located between the Large Generating Facility and the Participating TO's Transmission System at a site selected upon mutual agreement (not to be unreasonably withheld, conditioned or delayed) of the Parties. The Interconnection Customer shall be responsible for protection of the Large Generating Facility and the Interconnection Customer's other equipment from such conditions as negative sequence currents, over- or under-frequency, sudden load rejection, over- or under-voltage, and generator loss-of-field. The Interconnection Customer shall be solely responsible to disconnect the Large Generating Facility and the Interconnection Customer's other equipment if conditions on the ~~Transmission System~~ CAISO Controlled Grid could adversely affect the Large Generating Facility.

9.7.6 Power Quality. Neither ~~Party~~ the Participating TO's nor the Interconnection Customer's facilities shall cause excessive voltage flicker nor introduce excessive distortion to the sinusoidal voltage or current waves as defined by ANSI Standard C84.1-1989, in accordance with IEEE Standard 519, ~~or any applicable superseding electric industry~~ standard, or any alternative Applicable Reliability Standard or Applicable Reliability Council standard. In the event of a conflict ~~between~~ among ANSI Standard C84.1-1989, ~~or any applicable superseding electric industry standard, ANSI Standard C84.1-1989, or the applicable superseding electric industry standard, or any alternative Applicable Reliability Standard or Applicable Reliability Council standard, the alternative Applicable Reliability Standard or Applicable Reliability Council standard~~ shall control.

9.8 Switching and Tagging Rules. Each Party shall provide the other ~~Party~~ Parties a copy of its switching and tagging rules that are applicable to the other ~~Party's~~ Parties' activities. Such switching and tagging rules shall be developed on a non-discriminatory basis. The Parties shall comply with applicable switching and tagging rules, as amended from time to time, in obtaining clearances for work or for switching operations on equipment.

9.9 Use of Interconnection Facilities by Third Parties.

9.9.1 Purpose of Interconnection Facilities. Except as may be required by Applicable Laws and Regulations, or as otherwise agreed to among the Parties, the Interconnection Facilities shall be constructed for the sole purpose of interconnecting the Large Generating Facility to the Participating TO's Transmission System and shall be used for no other purpose.

9.9.2 Third Party Users. If required by Applicable Laws and Regulations or if the Parties mutually agree, such agreement not to be unreasonably withheld, to allow one or more third parties to use ~~Transmission Provider~~the Participating TO's Interconnection Facilities, or any part thereof, the Interconnection Customer will be entitled to compensation for the capital expenses it incurred in connection with the Interconnection Facilities based upon the pro rata use of the Interconnection Facilities by ~~Transmission Provider~~the Participating TO, all third party users, and the Interconnection Customer, in accordance with Applicable Laws and Regulations or upon some other mutually-agreed upon methodology. In addition, cost responsibility for ongoing costs, including operation and maintenance costs associated with the Interconnection Facilities, will be allocated between the Interconnection Customer and any third party users based upon the pro rata use of the Interconnection Facilities by ~~Transmission Provider~~the Participating TO, all third party users, and the Interconnection Customer, in accordance with Applicable Laws and Regulations or upon some other mutually agreed upon methodology. If the issue of such compensation or allocation cannot be resolved through such negotiations, it shall be submitted to FERC for resolution.

9.10 Disturbance Analysis Data Exchange. The Parties will cooperate with one another in the analysis of disturbances to either the Large Generating Facility or ~~Transmission Provider's Transmission System~~the CAISO Controlled Grid by gathering and providing access to any information relating to any disturbance, including information from oscillography, protective relay targets, breaker operations and sequence of events records, and any disturbance information required by Good Utility Practice.

~~Article 10. — Maintenance~~

ARTICLE 10. MAINTENANCE

10.1 ~~Transmission Provider~~Participating TO Obligations. ~~Transmission Provider~~The Participating TO shall maintain the Participating TO's Transmission System and ~~Transmission Provider~~the Participating TO's Interconnection Facilities in a safe and reliable manner and in accordance with this LGIA.

10.2 Interconnection Customer Obligations. The Interconnection Customer shall maintain the Large Generating Facility and the Interconnection Customer's Interconnection Facilities in a safe and reliable manner and in accordance with this LGIA.

10.3 Coordination. The Parties shall confer regularly to coordinate the planning, scheduling and performance of preventive and corrective maintenance on the Large Generating Facility and the Interconnection Facilities.

- 10.4 Secondary Systems.** ~~Each Party~~ The Participating TO and Interconnection Customer shall cooperate with the other Parties in the inspection, maintenance, and testing of control or power circuits that operate below 600 volts, AC or DC, including, but not limited to, any hardware, control or protective devices, cables, conductors, electric raceways, secondary equipment panels, transducers, batteries, chargers, and voltage and current transformers that directly affect the operation of a Party's facilities and equipment which may reasonably be expected to impact the other ~~Party~~ Parties. Each Party shall provide advance notice to the other ~~Party~~ Parties before undertaking any work on such circuits, especially on electrical circuits involving circuit breaker trip and close contacts, current transformers, or potential transformers.
- 10.5 Operating and Maintenance Expenses.** Subject to the provisions herein addressing the use of facilities by others, and except for operations and maintenance expenses associated with modifications made for providing interconnection or transmission service to a third party and such third party pays for such expenses, the Interconnection Customer shall be responsible for all reasonable expenses including overheads, associated with: (1) owning, operating, maintaining, repairing, and replacing the Interconnection Customer's Interconnection Facilities; and (2) operation, maintenance, repair and replacement of ~~Transmission Provider~~ the Participating TO's Interconnection Facilities.

~~Article 11. — Performance Obligation~~

ARTICLE 11. PERFORMANCE OBLIGATION

- 11.1 Interconnection Customer's Interconnection Facilities.** The Interconnection Customer shall design, procure, construct, install, own and/or control the Interconnection Customer's Interconnection Facilities described in Appendix A, ~~Interconnection Facilities, Network Upgrades and Distribution Upgrades~~, at its sole expense.
- 11.2 ~~Transmission Provider~~ Participating TO's Interconnection Facilities.** ~~Transmission Provider or Transmission Owner~~ The Participating TO shall design, procure, construct, install, own and/or control the ~~Transmission Provider~~ Participating TO's Interconnection Facilities described in Appendix A, ~~Interconnection Facilities, Network Upgrades and Distribution Upgrades~~, at the sole expense of the Interconnection Customer. Unless the Participating TO elects to fund the capital for the Participating TO's Interconnection Facilities, they shall be solely funded by the Interconnection Customer.
- 11.3 Network Upgrades and Distribution Upgrades.** ~~Transmission Provider or Transmission Owner~~ The Participating TO shall design, procure, construct, install, and own the Network Upgrades and Distribution Upgrades described in Appendix A, ~~Interconnection Facilities, Network Upgrades and Distribution Upgrades~~. The Interconnection Customer shall be responsible for all costs related to Distribution Upgrades. Unless ~~Transmission Provider or Transmission Owner~~ the Participating TO

elects to fund the capital for the Distribution Upgrades and Network Upgrades, they shall be ~~solely~~ funded by the Interconnection Customer ~~in an amount determined pursuant to the methodology set forth in Section 13 of the LGIP. This specific amount is set forth in Appendix G to this LGIA.~~

11.4 Transmission Credits. No later than thirty (30) Calendar Days prior to the Commercial Operation Date, the Interconnection Customer may make a one-time election by written notice to the CAISO and the Participating TO to receive Congestion Revenue Rights as defined in and as available under the CAISO Tariff at the time of the election in accordance with the CAISO Tariff, in lieu of a refund of the cost of Network Upgrades in accordance with Article 11.4.1.

11.4.1 Repayment of Amounts Advanced for Network Upgrades. Upon the Commercial Operation Date, the Interconnection Customer shall be entitled to a ~~cash~~ repayment, equal to the total amount paid to ~~Transmission Provider and Affected System Operator, if any, for the Network Upgrades, including the Participating TO for the costs of Network Upgrades for which it is responsible, as set forth in Appendix G.~~ Such amount shall include any tax gross-up or other tax-related payments associated with Network Upgrades, ~~and~~ not refunded to the Interconnection Customer pursuant to Article 5.17.8 or otherwise, ~~to~~ and shall be paid to the Interconnection Customer by the Participating TO on a dollar-for-dollar basis for the non-usage sensitive portion of transmission charges, as payments are made under Transmission Provider's Tariff and Affected System's Tariff for transmission services with respect to the Large Generating Facility. Any either through (1) direct payments made on a levelized basis over the five-year period commencing on the Commercial Operation Date; or (2) any alternative payment schedule that is mutually agreeable to the Interconnection Customer and Participating TO, provided that such amount is paid within five (5) years from the Commercial Operation Date. Notwithstanding the foregoing, if this LGIA terminates within five (5) years from the Commercial Operation Date, the Participating TO's obligation to pay refunds to the Interconnection Customer shall cease as of the date of termination. Any repayment shall include interest calculated in accordance with the methodology set forth in FERC's regulations at 18 C.F.R. § 35.19a(a)(2)(iii) from the date of any payment for Network Upgrades through the date on which the Interconnection Customer receives a repayment of such payment ~~pursuant to this subparagraph. Interconnection Customer may assign such repayment rights to any person. Notwithstanding the foregoing, Interconnection Customer, Transmission Provider, and Affected System Operator may adopt any alternative payment schedule that is mutually agreeable so long as Transmission Provider and Affected System Operator take one of the following actions no later than five years from the Commercial Operation Date: (1) return to Interconnection Customer any amounts advanced for Network Upgrades not previously repaid, or (2) declare in writing that Transmission Provider or Affected System Operator will continue to provide payments to Interconnection Customer on a dollar-for-dollar basis for the non-usage sensitive portion of transmission~~

~~charges, or develop an alternative schedule that is mutually agreeable and provides for the return of all amounts advanced for Network Upgrades not previously repaid; however, full reimbursement shall not extend beyond twenty (20) years from the Commercial Operation Date.~~ Interest shall continue to accrue on the repayment obligation so long as this LGIA is in effect. The Interconnection Customer may assign such repayment rights to any person.

If the Large Generating Facility fails to achieve ~~commercial operation~~ Commercial Operation, but it or another Generating Facility is later constructed and makes use of the Network Upgrades, ~~Transmission Provider and Affected System Operator~~ the Participating TO shall at that time reimburse Interconnection Customer for the amounts advanced for the Network Upgrades. Before any such reimbursement can occur, the Interconnection Customer, or the entity that ultimately constructs the Generating Facility, if different, is responsible for identifying ~~the~~ and demonstrating to the Participating TO the appropriate entity to which reimbursement must be made: in order to implement the intent of this reimbursement obligation.

11.4.2 Special Provisions for Affected Systems. ~~Unless Transmission Provider provides, under the LGIA, for the repayment of amounts advanced to Affected System Operator for Network Upgrades, The~~ Interconnection Customer and Affected System Operator shall enter into an agreement that provides for such repayment. The with the owner of the Affected System and/or other affected owners of portions of the CAISO Controlled Grid, as applicable, in accordance with the LGIP. Such agreement shall specify the terms governing payments to be made by the Interconnection Customer to the owner of the Affected System Operator and/or other affected owners of portions of the CAISO Controlled Grid as well as the repayment by the ~~Affected System Operator~~ owner of the Affected System and/or other affected owners of portions of the CAISO Controlled Grid. In no event shall the Participating TO be responsible for the repayment for any facilities that are not part of the Participating TO's Transmission System. In the event the Participating TO is a joint owner with an Affected System or with any other co-owner of a facility affected by the Large Generating Facility, the Participating TO's obligation to reimburse the Interconnection Customer for payments made to address the impacts of the Large Generating Facility on the system shall not exceed the proportionate amount of the cost of any upgrades attributable to the proportion of the jointly-owned facility owned by the Participating TO.

11.4.3 Notwithstanding any other provision of this LGIA, nothing herein shall be construed as relinquishing or foreclosing any rights, including but not limited to firm transmission rights, capacity rights, ~~transmission congestion rights~~ Congestion Revenue Rights, or transmission credits, that the Interconnection Customer, shall be entitled to, now or in the future under any other agreement or tariff as a result of, or otherwise associated with,

the transmission capacity, if any, created by the Network Upgrades, including the right to obtain cash reimbursements, merchant transmission Congestion Revenue Rights in accordance with Section 36.11 of the CAISO Tariff, or transmission credits for transmission service that is not associated with the Large Generating Facility.

~~11.5 — **Provision of Security.** At least thirty (30) Calendar Days prior to the commencement of the procurement, installation, or construction of a discrete portion of a Transmission Provider's Interconnection Facilities, Network Upgrades, or Distribution Upgrades, Interconnection Customer shall provide Transmission Provider, at Interconnection Customer's option, a guarantee, a surety bond, letter of credit or other form of security that is reasonably acceptable to Transmission Provider and is consistent with the Uniform Commercial Code of the jurisdiction identified in Article 14.2.1. Such security for payment shall be in an amount sufficient to cover the costs for constructing, procuring and installing the applicable portion of Transmission Provider's Interconnection Facilities, Network Upgrades, or Distribution Upgrades and shall be reduced on a dollar-for-dollar basis for payments made to Transmission Provider for these purposes.~~

~~— In addition:~~

~~11.5.1 — The guarantee must be made by an entity that meets the creditworthiness requirements of Transmission Provider, and contain terms and conditions that guarantee payment of any amount that may be due from Interconnection Customer, up to an agreed-to maximum amount.~~

~~11.5.2 — The letter of credit must be issued by a financial institution reasonably acceptable to Transmission Provider and must specify a reasonable expiration date.~~

~~11.5.3 — The surety bond must be issued by an insurer reasonably acceptable to Transmission Provider and must specify a reasonable expiration date.~~

11.5 **Provision of Interconnection Financial Security.** The Interconnection Customer is obligated to provide all necessary Interconnection Financial Security required under Section 9 of the LGIP in a manner acceptable under Section 9 of the LGIP. Failure to satisfy the LGIP's requirements for the provision of Interconnection Financial Security shall result in the Interconnection Request being deemed withdrawn and subject to LGIP Section 3.8.

11.6 Interconnection Customer Compensation. If ~~Transmission Provider~~the CAISO requests or directs the Interconnection Customer to provide a service pursuant to Articles 9.6.3 (Payment for Reactive Power), or 13.5.1 of this LGIA, ~~Transmission Provider~~the CAISO shall compensate the Interconnection Customer in accordance with ~~Interconnection Customer's applicable rate schedule then in effect unless the provision of such service(s) is subject to an RTO or ISO FERC approved rate schedule. Interconnection Customer shall serve Transmission Provider or RTO or ISO with any filing of a proposed rate schedule at the time of such filing with FERC. To the extent that no rate schedule is in effect at the time the Interconnection Customer is required to provide or absorb any Reactive Power under this LGIA, Transmission Provider agrees to compensate Interconnection Customer in such amount as would have been due Interconnection Customer had the rate schedule been in effect at~~

~~the time service commenced; provided, however, that such rate schedule must be filed at FERC or other appropriate Governmental Authority within sixty (60) Calendar Days of the commencement of service~~the CAISO Tariff.

11.6.1 Interconnection Customer Compensation for Actions During Emergency Condition. ~~Transmission Provider or RTO or ISO~~The CAISO shall compensate the Interconnection Customer in accordance with the CAISO Tariff for its provision of real and reactive power and other Emergency Condition services that the Interconnection Customer provides to support the ~~Transmission System~~CAISO Controlled Grid during an Emergency Condition in accordance with Article 11.6.

~~Article 12. Invoice~~

ARTICLE 12. INVOICE

12.1 General. ~~Each Party~~The Participating TO shall submit to the ~~other Party~~Interconnection Customer, on a monthly basis, invoices of amounts due pursuant to this LGIA for the preceding month. Each invoice shall state the month to which the invoice applies and fully describe the services and equipment provided. The Parties may discharge mutual debts and payment obligations due and owing to each other on the same date through netting, in which case all amounts a Party owes to the other Party under this LGIA, including interest payments or credits, shall be netted so that only the net amount remaining due shall be paid by the owing Party. Notwithstanding the foregoing, any invoices between the CAISO and another Party shall be submitted and paid in accordance with the CAISO Tariff.

12.2 Final Invoice. ~~Within six~~As soon as reasonably practicable, but within twelve months after completion of the construction of ~~Transmission Provider's~~the Participating TO's Interconnection Facilities ~~and the~~ Network Upgrades, ~~Transmission Provider's~~and Distribution Upgrades, the Participating TO shall provide an invoice of the final cost of the construction of ~~Transmission Provider's~~the Participating TO's Interconnection Facilities ~~and the~~ Network Upgrades, and Distribution Upgrades, and shall set forth such costs in sufficient detail to enable the Interconnection Customer to compare the actual costs with the estimates and to ascertain deviations, if any, from the cost estimates. ~~Transmission Provider~~With respect to costs associated with the Participating TO's Interconnection Facilities and Distribution Upgrades, the Participating TO shall refund to the Interconnection Customer any amount by which the actual payment by the Interconnection Customer for estimated costs exceeds the actual costs of construction within thirty (30) Calendar Days of the issuance of such final construction invoice; or, in the event the actual costs of construction exceed the Interconnection Customer's actual payment for estimated costs, then the Interconnection Customer shall pay to the Participating TO any amount by which the actual costs of construction exceed the actual payment by the Interconnection Customer for estimated costs within thirty (30) Calendar Days of

the issuance of such final construction invoice. With respect to costs associated with Network Upgrades, the Participating TO shall refund to the Interconnection Customer any amount by which the actual payment by the Interconnection Customer for estimated costs exceeds the actual costs of construction multiplied by the Interconnection Customer's percentage share of those costs, as set forth in Appendix G to this LGIA within thirty (30) Calendar Days of the issuance of such final construction invoice. In the event the actual costs of construction multiplied by the Interconnection Customer's percentage share of those costs exceed the Interconnection Customer's actual payment for estimated costs, then the Participating TO shall recover such difference through its transmission service rates.

12.3 Payment. Invoices shall be rendered to the ~~paying Party~~Interconnection Customer at the address specified in Appendix F. The ~~Party receiving the invoice shall pay the invoice~~Interconnection Customer shall pay, or Participating TO shall refund, the amounts due within thirty (30) Calendar Days of the Interconnection Customer's receipt of the invoice. All payments shall be made in immediately available funds payable to the ~~other Party~~Interconnection Customer or Participating TO, or by wire transfer to a bank named and account designated by the invoicing ~~Party~~Interconnection Customer or Participating TO. Payment of invoices by ~~either~~any Party will not constitute a waiver of any rights or claims ~~either~~any Party may have under this LGIA.

12.4 Disputes. In the event of a billing dispute between ~~Transmission Provider and the~~ Interconnection Customer, ~~Transmission Provider and the Participating TO, the Participating TO and the CAISO~~ shall continue to provide Interconnection Service under this LGIA as long as the Interconnection Customer: (i) continues to make all payments not in dispute; and (ii) pays to ~~Transmission Provider~~the Participating TO or into an independent escrow account the portion of the invoice in dispute, pending resolution of such dispute. If the Interconnection Customer fails to meet these two requirements for continuation of service, then ~~Transmission Provider~~the Participating TO may provide notice to the Interconnection Customer of a Default pursuant to Article 17. Within thirty (30) Calendar Days after the resolution of the dispute, the Party that owes money to the other Party shall pay the amount due with interest calculated in ~~accord~~accordance with the methodology set forth in FERC's ~~regulations at 18 CFR § 35.19a(a)(2)(iii)~~Regulations at 18 C.F.R. § 35.19a(a)(2)(iii). Notwithstanding the foregoing, any billing dispute between the CAISO and another Party shall be resolved in accordance with the provisions of Article 27 of this LGIA.

~~Article 13. — Emergencies~~

ARTICLE 13. EMERGENCIES

~~13.1 — Definition. "Emergency Condition" shall mean a condition or situation: (i) that in the judgment of the Party making the claim is imminently likely to endanger life or property; or (ii) that, in the case of Transmission Provider, is imminently likely (as determined in a non-discriminatory~~

manner) to cause a material adverse effect on the security of, or damage to the Transmission System, Transmission Provider's Interconnection Facilities or the Transmission Systems of others to which the Transmission System is directly connected; or (iii) that, in the case of Interconnection Customer, is imminently likely (as determined in a non-discriminatory manner) to cause a material adverse effect on the security of, or damage to, the Large Generating Facility or Interconnection Customer's Interconnection Facilities' System restoration and black start shall be considered Emergency Conditions; provided, that Interconnection Customer is not obligated by this LGIA to possess black start capability.

13.1 [Reserved]

13.2 Obligations. Each Party shall comply with the Emergency Condition procedures of the ~~applicable ISO/RTO~~ CAISO, NERC, the Applicable Reliability Council, Applicable Reliability Standards, Applicable Laws and Regulations, and any emergency procedures ~~agreed to by the Joint Operating Committee~~ set forth in this LGIA.

13.3 Notice. ~~Transmission Provider~~ The Participating TO or the CAISO shall notify the Interconnection Customer promptly when it becomes aware of an Emergency Condition that affects ~~Transmission Provider~~ the Participating TO's Interconnection Facilities or ~~the Transmission~~ Distribution System or the CAISO Controlled Grid, respectively, that may reasonably be expected to affect the Interconnection Customer's operation of the Large Generating Facility or the Interconnection Customer's Interconnection Facilities. The Interconnection Customer shall notify ~~Transmission Provider~~ the Participating TO and the CAISO promptly when it becomes aware of an Emergency Condition that affects the Large Generating Facility or the Interconnection Customer's Interconnection Facilities that may reasonably be expected to affect the ~~Transmission System or Transmission Provider~~ CAISO Controlled Grid or the Participating TO's Interconnection Facilities. To the extent information is known, the notification shall describe the Emergency Condition, the extent of the damage or deficiency, the expected effect on the operation of the Interconnection Customer's or ~~Transmission Provider~~ Participating TO's facilities and operations, its anticipated duration and the corrective action taken and/or to be taken. The initial notice shall be followed as soon as practicable with written notice, if requested by a Party, which may be provided by electronic mail or facsimile, or in the case of the CAISO may be publicly posted on the CAISO's internet web site.

13.4 Immediate Action. Unless, in the Interconnection Customer's reasonable judgment, immediate action is required, the Interconnection Customer shall obtain the consent of ~~Transmission Provider~~ the CAISO and the Participating TO, such consent to not be unreasonably withheld, prior to performing any manual switching operations at the Large Generating Facility or the Interconnection Customer's Interconnection Facilities in response to an Emergency Condition ~~either declared by Transmission Provider or otherwise regarding the Transmission System~~ the Participating TO or CAISO or in response to any other emergency condition.

13.5 ~~Transmission Provider~~ CAISO and Participating TO Authority.

13.5.1 General. ~~Transmission Provider~~ The CAISO and Participating TO may take whatever actions or inactions, including issuance of dispatch instructions, with regard to the ~~Transmission System or Transmission Provider~~ CAISO Controlled Grid or the Participating TO's Interconnection Facilities ~~it deems~~ or Distribution System they deem necessary during an Emergency Condition in order to (i) preserve public health and safety, (ii) preserve the reliability of the ~~Transmission System or Transmission Provider~~ CAISO Controlled Grid or the Participating TO's Interconnection Facilities, or Distribution System, and (iii) limit or prevent damage, and (iv) expedite restoration of service.

~~Transmission Provider~~ The Participating TO and the CAISO shall use Reasonable Efforts to minimize the effect of such actions or inactions on the Large Generating Facility or the Interconnection Customer's Interconnection Facilities. ~~Transmission Provider~~ The Participating TO or the CAISO may, on the basis of technical considerations, require the Large Generating Facility to mitigate an Emergency Condition by taking actions necessary and limited in scope to remedy the Emergency Condition, including, but not limited to, directing the Interconnection Customer to shut-down, start-up, increase or decrease the real or reactive power output of the Large Generating Facility; implementing a reduction or disconnection pursuant to Article 13.5.2; directing the Interconnection Customer to assist with ~~blackstart~~ black start (if available) or restoration efforts; or altering the outage schedules of the Large Generating Facility and the Interconnection Customer's Interconnection Facilities. Interconnection Customer shall comply with all of ~~Transmission Provider~~ the CAISO's and Participating TO's operating instructions concerning Large Generating Facility real power and reactive power output within the manufacturer's design limitations of the Large Generating Facility's equipment that is in service and physically available for operation at the time, in compliance with Applicable Laws and Regulations.

13.5.2 Reduction and Disconnection. ~~Transmission Provider~~ The Participating TO or the CAISO may reduce Interconnection Service or disconnect the Large Generating Facility or the Interconnection Customer's Interconnection Facilities, when such, reduction or disconnection is necessary under Good Utility Practice due to Emergency Conditions. These rights are separate and distinct from any right of curtailment of ~~Transmission Provider~~ the CAISO pursuant to ~~Transmission Provider's~~ the CAISO Tariff. When ~~Transmission Provider~~ the CAISO or Participating TO can schedule the reduction or disconnection in advance, ~~Transmission Provider~~ the CAISO or Participating TO shall notify the Interconnection Customer of the reasons, timing and expected duration of the reduction or disconnection. ~~Transmission Provider~~ The CAISO or Participating TO shall coordinate with the Interconnection Customer using Good Utility Practice to schedule the

reduction or disconnection during periods of least impact to the Interconnection Customer and ~~Transmission Provider~~the CAISO and Participating TO. Any reduction or disconnection shall continue only for so long as reasonably necessary under Good Utility Practice. The Parties shall cooperate with each other to restore the Large Generating Facility, the Interconnection Facilities, and the ~~Transmission System~~CAISO Controlled Grid to their normal operating state as soon as practicable consistent with Good Utility Practice.

13.6 Interconnection Customer Authority. Consistent with Good Utility Practice ~~and the, this~~ LGIA, and the ~~LGIP,~~CAISO Tariff, the Interconnection Customer may take actions or inactions with regard to the Large Generating Facility or the Interconnection Customer's Interconnection Facilities during an Emergency Condition in order to (i) preserve public health and safety, (ii) preserve the reliability of the Large Generating Facility or the Interconnection Customer's Interconnection Facilities, (iii) limit or prevent damage, and (iv) expedite restoration of service. Interconnection Customer shall use Reasonable Efforts to minimize the effect of such actions or inactions on the ~~Transmission System and Transmission Provider~~CAISO Controlled Grid and the Participating TO's Interconnection Facilities. ~~Transmission Provider~~The CAISO and Participating TO shall use Reasonable Efforts to assist Interconnection Customer in such actions.

13.7 Limited Liability. Except as otherwise provided in Article 11.6.1 of this LGIA, ~~neither~~no Party shall be liable to ~~the~~any other Party for any action it takes in responding to an Emergency Condition so long as such action is made in good faith and is consistent with Good Utility Practice.

~~Article 14. — Regulatory Requirements and Governing Law~~

ARTICLE 14. REGULATORY REQUIREMENTS AND GOVERNING LAW

14.1 Regulatory Requirements. Each Party's obligations under this LGIA shall be subject to its receipt of any required approval or certificate from one or more Governmental Authorities in the form and substance satisfactory to the applying Party, or the Party making any required filings with, or providing notice to, such Governmental Authorities, and the expiration of any time period associated therewith. Each Party shall in good faith seek and use its Reasonable Efforts to obtain such other approvals. Nothing in this LGIA shall require the Interconnection Customer to take any action that could result in its inability to obtain, or its loss of, status or exemption under the Federal Power Act, ~~or~~ the Public Utility Holding Company Act of 1935, as amended, or the Public Utility Regulatory Policies Act of ~~1978,~~1978, or the Energy Policy Act of 2005.

14.2 Governing Law.

14.2.1 The validity, interpretation and performance of this LGIA and each of its provisions shall be governed by the laws of the state where the Point of Interconnection is located, without regard to its conflicts of law principles.

14.2.2 This LGIA is subject to all Applicable Laws and Regulations.

14.2.3 Each Party expressly reserves the right to seek changes in, appeal, or otherwise contest any laws, orders, rules, or regulations of a Governmental Authority.

~~Article 15. — Notices.~~

ARTICLE 15. NOTICES

15.1 General. Unless otherwise provided in this LGIA, any notice, demand or request required or permitted to be given by ~~either a~~ Party to ~~the other~~another and any instrument required or permitted to be tendered or delivered by ~~either a~~ Party in writing to ~~the other~~another shall be effective when delivered and may be so given, tendered or delivered, by recognized national courier, or by depositing the same with the United States Postal Service with postage prepaid, for delivery by certified or registered mail, addressed to the Party, or personally delivered to the Party, at the address set out in Appendix F, Addresses for Delivery of Notices and Billings.

~~Either~~A Party must update the information in Appendix F as information changes.
A Party may change the notice information in this LGIA by giving five (5) Business Days written notice prior to the effective date of the change. Such changes shall not constitute an amendment to this LGIA.

15.2 Billings and Payments. Billings and payments shall be sent to the addresses set out in Appendix F.

15.3 Alternative Forms of Notice. Any notice or request required or permitted to be given by a Party to ~~the other~~another and not required by this ~~Agreement~~LGIA to be given in writing may be so given by telephone, facsimile or ~~email~~e-mail to the telephone numbers and ~~email~~e-mail addresses set out in Appendix F.

15.4 Operations and Maintenance Notice . Each Party shall notify the other ~~Party~~Parties in writing of the identity of the person(s) that it designates as the point(s) of contact with respect to the implementation of Articles 9 and 10.

~~Article 16. — Force Majeure~~

ARTICLE 16. FORCE MAJEURE

16.1 Force Majeure.

16.1.1 Economic hardship is not considered a Force Majeure event.

16.1.2 ~~Neither~~No Party shall be considered to be in Default with respect to any obligation hereunder, (including obligations under Article 4), other than the obligation to pay money when due, if prevented from fulfilling such obligation by Force Majeure. A Party unable to fulfill any obligation hereunder (other than an obligation to pay money when due) by reason of Force Majeure shall give notice and the full particulars of such Force Majeure to the other Party in writing or by telephone as soon as reasonably possible after the occurrence of the cause relied upon. Telephone notices given pursuant to this ~~article~~Article shall be confirmed in writing as soon as reasonably possible and shall specifically state full particulars of the Force Majeure, the time and date when the Force Majeure occurred and when the Force Majeure is reasonably expected to cease. The Party affected shall exercise due diligence to remove such disability with reasonable dispatch, but shall not be required to accede or agree to any provision not satisfactory to it in order to settle and terminate a strike or other labor disturbance.

~~Article 17. — Default~~

ARTICLE 17. DEFAULT

17.1 Default.

17.1.1 General. No Default shall exist where such failure to discharge an obligation (other than the payment of money) is the result of Force Majeure as defined in this LGIA or the result of an act ~~of~~or omission of the other Party. Upon a Breach, the affected ~~non-breaching~~Breaching Party(ies) shall give written notice of such Breach to the ~~breaching~~Breaching Party. Except as provided in Article 17.1.2, the ~~breaching~~Breaching Party shall have thirty (30) Calendar Days from receipt of the Default notice within which to cure such Breach; provided however, if such Breach is not capable of cure within thirty (30) Calendar Days, the ~~breaching~~Breaching Party shall commence such cure within thirty (30) Calendar Days after notice and continuously and diligently complete such cure within ninety (90) Calendar Days from receipt of the Default notice; and, if cured within such time, the Breach specified in such notice shall cease to exist.

17.1.2 Right to Terminate. If a Breach is not cured as provided in this ~~article~~Article, or if a Breach is not capable of being cured within the period

provided for herein, the ~~affected~~ non-~~breaching~~Breaching Party(ies) shall have the right to declare a Default and terminate this LGIA by written notice at any time until cure occurs, and be relieved of any further obligation hereunder and, whether or not ~~that~~such Party(ies) terminates this LGIA, to recover from the ~~breaching~~Breaching Party all amounts due hereunder, plus all other damages and remedies to which it is entitled at law or in equity. The provisions of this ~~article~~Article will survive termination of this LGIA.

Article 18. — Indemnity, Consequential Damages and Insurance

ARTICLE 18. INDEMNITY, CONSEQUENTIAL DAMAGES AND INSURANCE

18.1 Indemnity. ~~The Parties~~Each Party shall at all times indemnify, defend, and hold the other ~~Party~~Parties harmless from, any and all ~~damages, losses, claims, including claims and actions relating to injury to or death of any person or damage to property, demand, suits, recoveries, costs and expenses, court costs, attorney fees, and all other obligations by or to third parties,~~Losses arising out of or resulting from ~~the other~~another Party's action or inactions of its obligations under this LGIA on behalf of the ~~Indemnifying~~indemnifying Party, except in cases of gross negligence or intentional wrongdoing by the Indemnified Party.

18.1.1 Indemnified ~~Person~~Party. If an Indemnified ~~Person~~Party is entitled to indemnification under this Article 18 as a result of a claim by a third party, and the Indemnifying Party fails, after notice and reasonable opportunity to proceed under Article 18.1, to assume the defense of such claim, such Indemnified ~~Person~~Party may at the expense of the Indemnifying Party contest, settle or consent to the entry of any judgment with respect to, or pay in full, such claim.

18.1.2 Indemnifying Party. If an Indemnifying Party is obligated to indemnify and hold any Indemnified ~~Person~~Party harmless under this Article 18, the amount owing to the Indemnified ~~Person~~Party shall be the amount of such Indemnified ~~Person~~Party's actual Loss, net of any insurance or other recovery.

18.1.3 Indemnity Procedures. Promptly after receipt by an Indemnified ~~Person~~Party of any claim or notice of the commencement of any action or administrative or legal proceeding or investigation as to which the indemnity provided for in Article 18.1 may apply, the Indemnified ~~Person~~Party shall notify the Indemnifying Party of such fact. Any failure of or delay in such notification shall not affect a Party's indemnification obligation unless such failure or delay is materially prejudicial to the ~~Indemnifying~~indemnifying Party.

The Indemnifying Party shall have the right to assume the defense thereof with counsel designated by such Indemnifying Party and reasonably

satisfactory to the Indemnified ~~Person~~Party. If the defendants in any such action include one or more Indemnified ~~Persons~~Parties and the Indemnifying Party and if the Indemnified ~~Person~~Party reasonably concludes that there may be legal defenses available to it and/or other Indemnified ~~Persons~~Parties which are different from or additional to those available to the Indemnifying Party, the Indemnified ~~Person~~Party shall have the right to select separate counsel to assert such legal defenses and to otherwise participate in the defense of such action on its own behalf. In such instances, the Indemnifying Party shall only be required to pay the fees and expenses of one additional attorney to represent an Indemnified ~~Person~~Party or Indemnified ~~Persons~~Parties having such differing or additional legal defenses.

The Indemnified ~~Person~~Party shall be entitled, at its expense, to participate in any such action, suit or proceeding, the defense of which has been assumed by the Indemnifying Party. Notwithstanding the foregoing, the Indemnifying Party (i) shall not be entitled to assume and control the defense of any such action, suit or proceedings if and to the extent that, in the opinion of the Indemnified ~~Person~~Party and its counsel, such action, suit or proceeding involves the potential imposition of criminal liability on the Indemnified ~~Person~~Party, or there exists a conflict or adversity of interest between the Indemnified ~~Person~~Party and the Indemnifying Party, in such event the Indemnifying Party shall pay the reasonable expenses of the Indemnified ~~Person~~Party, and (ii) shall not settle or consent to the entry of any judgment in any action, suit or proceeding without the consent of the Indemnified ~~Person~~Party, which shall not be ~~reasonably~~unreasonably withheld, conditioned or delayed.

18.2 Consequential Damages. Other than the ~~Liquidated Damages~~liquidated damages heretofore described, ~~in Article 5.3,~~ in no event shall ~~either~~any Party be liable under any provision of this LGIA for any losses, damages, costs or expenses for any special, indirect, incidental, consequential, or punitive damages, including but not limited to loss of profit or revenue, loss of the use of equipment, cost of capital, cost of temporary equipment or services, whether based in whole or in part in contract, in tort, including negligence, strict liability, or any other theory of liability; provided, however, that damages for which a Party may be liable to ~~the~~ ~~other~~another Party under another agreement will not be considered to be special, indirect, incidental, or consequential damages hereunder.

18.3 Insurance. Each ~~party~~Party shall, at its own expense, maintain in force throughout the period of this LGIA, and until released by the other ~~Party~~Parties, the following minimum insurance coverages, with insurers rated no less than A- (with a minimum size rating of VII) by Bests' Insurance Guide and Key Ratings and authorized to do business in the state where the Point of Interconnection is located, except in the case of the CAISO, the State of California:

- 18.3.1** ~~Employers~~Employer's Liability and Workers' Compensation Insurance providing statutory benefits in accordance with the laws and regulations of the state in which the Point of Interconnection is located, except in the case of the CAISO, the State of California.
- 18.3.2** Commercial General Liability Insurance including premises and operations, personal injury, broad form property damage, broad form blanket contractual liability coverage (including coverage for the contractual indemnification) products and completed operations coverage, coverage for explosion, collapse and underground hazards, independent contractors coverage, coverage for pollution to the extent normally available and punitive damages to the extent normally available and a cross liability endorsement, with minimum limits of One Million Dollars (\$1,000,000) per occurrence/One Million Dollars (\$1,000,000) aggregate combined single limit for personal injury, bodily injury, including death and property damage.
- 18.3.3** ~~Comprehensive~~Business Automobile Liability Insurance for coverage of owned and non-owned and hired vehicles, trailers or semi-trailers designed for travel on public roads, with a minimum, combined single limit of One Million Dollars (\$1,000,000) per occurrence for bodily injury, including death, and property damage.
- 18.3.4** Excess Public Liability Insurance over and above the ~~Employers~~Employer's Liability Commercial General Liability and ~~Comprehensive~~Business Automobile Liability Insurance coverage, with a minimum combined single limit of Twenty Million Dollars (\$20,000,000) per occurrence/Twenty Million Dollars (\$20,000,000) aggregate.
- 18.3.5** The Commercial General Liability Insurance, ~~Comprehensive~~Business Automobile Insurance and Excess Public Liability Insurance policies shall name the other ~~Party, its parent~~Parties, their parents, associated and Affiliate companies and their respective directors, officers, agents, servants and employees ("Other Party Group") as additional insured. All policies shall contain provisions whereby the insurers waive all rights of subrogation in accordance with the provisions of this LGIA against the Other Party Group and provide thirty (30) ~~Calender~~Calendar Days advance written notice to the Other Party Group prior to anniversary date of cancellation or any material change in coverage or condition.
- 18.3.6** The Commercial General Liability Insurance, ~~Comprehensive~~Business Automobile Liability Insurance and Excess Public Liability Insurance policies shall contain provisions that specify that the policies are primary and shall apply to such extent without consideration for other policies separately carried and shall state that each insured is provided coverage as though a separate policy had been issued to each, except the

insurer's liability shall not be increased beyond the amount for which the insurer would have been liable had only one insured been covered. Each Party shall be responsible for its respective deductibles or retentions.

- 18.3.7** The Commercial General Liability Insurance, ~~Comprehensive~~Business Automobile Liability Insurance and Excess Public Liability Insurance policies, if written on a Claims First Made Basis, shall be maintained in full force and effect for two (2) years after termination of this LGIA, which coverage may be in the form of tail coverage or extended reporting period coverage if agreed by the Parties.
- 18.3.8** The requirements contained herein as to the types and limits of all insurance to be maintained by the Parties are not intended to and shall not in any manner, limit or qualify the liabilities and obligations assumed by the Parties under this LGIA.
- 18.3.9** Within ten (10) ~~days~~Calendar Days following execution of this LGIA, and as soon as practicable after the end of each fiscal year or at the renewal of the insurance policy and in any event within ninety (90) ~~days~~Calendar Days thereafter, each Party shall provide certification of all insurance required in this LGIA, executed by each insurer or by an authorized representative of each insurer.
- 18.3.10** Notwithstanding the foregoing, each Party may self-insure to meet the minimum insurance requirements of Articles 18.3.2 through 18.3.8 to the extent it maintains a self-insurance program; provided that, such Party's senior ~~secured debt is rated at investment grade~~unsecured debt or issuer rating is BBB-, or better, as rated by Standard & Poor's and that its self-insurance program meets the minimum insurance requirements of Articles 18.3.2 through 18.3.8. For any period of time that a Party's senior ~~secured debt is~~unsecured debt rating and issuer rating are both unrated by Standard & Poor's or ~~is~~are both rated at less than ~~investment grade~~BBB- by Standard & Poor's, such Party shall comply with the insurance requirements applicable to it under Articles 18.3.2 through 18.3.9. In the event that a Party is permitted to self-insure pursuant to this ~~article,~~Article 18.3.10, it shall notify the other ~~Party~~Parties that it meets the requirements to self-insure and that its self-insurance program meets the minimum insurance requirements in a manner consistent with that specified in Article 18.3.9.
- 18.3.11** The Parties agree to report to each other in writing as soon as practical all accidents or occurrences resulting in injuries to any person, including death, and any property damage arising out of this LGIA.

~~Article 19. — Assignment~~

ARTICLE 19. ASSIGNMENT

19.1 Assignment. This LGIA may be assigned by ~~either a~~ Party only with the written consent of the other Parties; provided that ~~either a~~ Party may assign this LGIA without the consent of the other ~~Party~~Parties to any Affiliate of the assigning Party with an equal or greater credit rating and with the legal authority and operational ability to satisfy the obligations of the assigning Party under this LGIA; and provided further that the Interconnection Customer shall have the right to assign this LGIA, without the consent of ~~Transmission Provider~~the CAISO or Participating TO, for collateral security purposes to aid in providing financing for the Large Generating Facility, provided that the Interconnection Customer will promptly notify ~~Transmission Provider~~the CAISO and Participating TO of any such assignment. Any financing arrangement entered into by the Interconnection Customer pursuant to this ~~article~~Article will provide that prior to or upon the exercise of the secured party's, trustee's or mortgagee's assignment rights pursuant to said arrangement, the secured creditor, the trustee or mortgagee will notify ~~Transmission Provider~~the CAISO and Participating TO of the date and particulars of any such exercise of assignment right(s), including providing the ~~Transmission Provider~~CAISO and Participating TO with proof that it meets the requirements of Articles 11.5 and 18.3. Any attempted assignment that violates this ~~article~~Article is void and ineffective. Any assignment under this LGIA shall not relieve a Party of its obligations, nor shall a Party's obligations be enlarged, in whole or in part, by reason thereof. Where required, consent to assignment will not be unreasonably withheld, conditioned or delayed.

~~Article 20. — Severability~~

ARTICLE 20. SEVERABILITY

20.1 Severability. If any provision in this LGIA is finally determined to be invalid, void or unenforceable by any court or other Governmental Authority having jurisdiction, such determination shall not invalidate, void or make unenforceable any other provision, agreement or covenant of this LGIA; provided that if the Interconnection Customer (or any third party, but only if such third party is not acting at the direction of ~~Transmission Provider~~the Participating TO or CAISO) seeks and obtains such a final determination with respect to any provision of the Alternate Option (Article 5.1.2), or the Negotiated Option (Article 5.1.4), then none of ~~these~~the provisions of Article 5.1.2 or 5.1.4 shall thereafter have any force or effect and the Parties' rights and obligations shall be governed solely by the Standard Option (Article 5.1.1).

~~Article 21. — Comparability~~

ARTICLE 21. COMPARABILITY

21.1 Comparability. The Parties will comply with all applicable comparability and code of conduct laws, rules and regulations, as amended from time to time.

~~Article 22. — Confidentiality~~

ARTICLE 22. CONFIDENTIALITY

22.1 Confidentiality. Confidential Information shall include, without limitation, all information relating to a Party's technology, research and development, business affairs, and pricing, and any information supplied by ~~either~~ any of the Parties to the other Parties prior to the execution of this LGIA.

Information is Confidential Information only if it is clearly designated or marked in writing as confidential on the face of the document, or, if the information is conveyed orally or by inspection, if the Party providing the information orally informs the ~~Party~~ Parties receiving the information that the information is confidential.

If requested by ~~either~~ any Party, the other ~~Party~~ Parties shall provide in writing, the basis for asserting that the information referred to in this Article 22 warrants confidential treatment, and the requesting Party may disclose such writing to the appropriate Governmental Authority. Each Party shall be responsible for the costs associated with affording confidential treatment to its information.

22.1.1 Term. During the term of this LGIA, and for a period of three (3) years after the expiration or termination of this LGIA, except as otherwise provided in this Article 22, each Party shall hold in confidence and shall not disclose to any person Confidential Information.

22.1.2 Scope. Confidential Information shall not include information that the receiving Party can demonstrate: (1) is generally available to the public other than as a result of a disclosure by the receiving Party; (2) was in the lawful possession of the receiving Party on a non-confidential basis before receiving it from the disclosing Party; (3) was supplied to the receiving Party without restriction by a third party, who, to the knowledge of the receiving Party after due inquiry, was under no obligation to the disclosing Party to keep such information confidential; (4) was independently developed by the receiving Party without reference to Confidential Information of the disclosing Party; (5) is, or becomes, publicly known, through no wrongful act or omission of the receiving Party or Breach of this LGIA; or (6) is required, in accordance with Article 22.1.7 of ~~the~~ this LGIA, Order of Disclosure, to be disclosed by any Governmental Authority or is otherwise required to be disclosed by law or subpoena, or is

necessary in any legal proceeding establishing rights and obligations under this LGIA. Information designated as Confidential Information will no longer be deemed confidential if the Party that designated the information as confidential notifies the other ~~Party~~Parties that it no longer is confidential.

22.1.3 Release of Confidential Information. ~~Neither~~No Party shall release or disclose Confidential Information to any other person, except to its employees, consultants, Affiliates (limited by the Standards of Conduct requirements set forth in Part 358 of FERC's Regulations, 18 C.F.R. 358), subcontractors, ~~employees, consultants,~~ or to parties who may be or considering providing financing to or equity participation with the Interconnection Customer, or to potential purchasers or assignees of the Interconnection Customer, on a need-~~to~~-know basis in connection with this LGIA, unless such person has first been advised of the confidentiality provisions of this Article 22 and has agreed to comply with such provisions. Notwithstanding the foregoing, a Party providing Confidential Information to any person shall remain primarily responsible for any release of Confidential Information in contravention of this Article 22.

22.1.4 Rights. Each Party retains all rights, title, and interest in the Confidential Information that each Party discloses to the other ~~Party~~Parties. The disclosure by each Party to the other ~~Party~~Parties of Confidential Information shall not be deemed a waiver by ~~either~~a Party or any other person or entity of the right to protect the Confidential Information from public disclosure.

22.1.5 No Warranties. ~~By providing~~The mere fact that a Party has provided Confidential Information, ~~neither Party makes any warranties or representations~~ does not constitute a warranty or representation as to its accuracy or completeness. In addition, by supplying Confidential Information, ~~neither~~no Party obligates itself to provide any particular information or Confidential Information to the other ~~Party~~Parties nor to enter into any further agreements or proceed with any other relationship or joint venture.

22.1.6 Standard of Care. Each Party shall use at least the same standard of care to protect Confidential Information it receives as it uses to protect its own Confidential Information from unauthorized disclosure, publication or dissemination. Each Party may use Confidential Information solely to fulfill its obligations to the other ~~Party~~Parties under this LGIA or its regulatory requirements.

22.1.7 Order of Disclosure. If a court or a Government Authority or entity with the right, power, and apparent authority to do so requests or requires ~~either~~any Party, by subpoena, oral

deposition, interrogatories, requests for production of documents, administrative order, or otherwise, to disclose Confidential Information, that Party shall provide the other ~~Party~~Parties with prompt notice of such request(s) or requirement(s) so that the other ~~Party~~Parties may seek an appropriate protective order or waive compliance with the terms of this LGIA. Notwithstanding the absence of a protective order or waiver, the Party may disclose such Confidential Information which, in the opinion of its counsel, the Party is legally compelled to disclose. Each Party will use Reasonable Efforts to obtain reliable assurance that confidential treatment will be accorded any Confidential Information so furnished.

22.1.8 Termination of Agreement. Upon termination of this LGIA for any reason, each Party shall, within ten (10) Calendar Days of receipt of a written request from ~~the other~~another Party, use Reasonable Efforts to destroy, erase, or delete (with such destruction, erasure, and deletion certified in writing to the other Party) or return to the other Party, without retaining copies thereof, any and all written or electronic Confidential Information received from the other Party.

22.1.9 Remedies. The Parties agree that monetary damages would be inadequate to compensate a Party for ~~the other~~another Party's Breach of its obligations under this Article 22. Each Party accordingly agrees that the other ~~Party~~Parties shall be entitled to equitable relief, by way of injunction or otherwise, if the first Party Breaches or threatens to Breach its obligations under this Article 22, which equitable relief shall be granted without bond or proof of damages, and the receiving Party shall not plead in defense that there would be an adequate remedy at law. Such remedy shall not be deemed an exclusive remedy for the Breach of this Article 22, but shall be in addition to all other remedies available at law or in equity. The Parties further acknowledge and agree that the covenants contained herein are necessary for the protection of legitimate business interests and are reasonable in scope. No Party, however, shall be liable for indirect, incidental, or consequential or punitive damages of any nature or kind resulting from or arising in connection with this Article 22.

22.1.10 Disclosure to FERC, its Staff, or a State. Notwithstanding anything in this Article 22 to the contrary, and pursuant to 18 ~~CFR~~CFR.C.F.R. section 1b.20, if FERC or its staff, during the course of an investigation or otherwise, requests information from one of the Parties that is otherwise required to be maintained in confidence pursuant to this LGIA, the Party shall provide the requested information to FERC or its staff, within the time provided for in the request for information. In providing the information to FERC or its staff, the Party must, consistent with 18 ~~CFR~~CFR.C.F.R. section 388.112, request that the information be treated as confidential and non-public by FERC and its staff and that the information be withheld from public disclosure. Parties are prohibited from notifying the other

~~Party~~Parties to this LGIA prior to the release of the Confidential Information to FERC or its staff. The Party shall notify the other ~~Party~~Parties to the LGIA when it is notified by FERC or its staff that a request to release Confidential Information has been received by FERC, at which time ~~either~~any of the Parties may respond before such information would be made public, pursuant to 18 ~~CFR~~C.F.R. section 388.112. Requests from a state regulatory body conducting a confidential investigation shall be treated in a similar manner if consistent with the applicable state rules and regulations.

22.1.11 Subject to the exception in Article 22.1.10, ~~any information that a Party claims is competitively sensitive, commercial or financial information under this LGIA ("Confidential Information")~~ shall not be disclosed by the other ~~Party~~Parties to any person not employed or retained by the other ~~Party~~Parties, except to the extent disclosure is (i) required by law; (ii) reasonably deemed by the disclosing Party to be required to be disclosed in connection with a dispute between or among the Parties, or the defense of litigation or dispute; (iii) otherwise permitted by consent of the other ~~Party~~Parties, such consent not to be unreasonably withheld; or (iv) necessary to fulfill its obligations under this LGIA or as a transmission service provider or a ~~Control Area operator~~Balancing Authority including disclosing the Confidential Information to an RTO or ISO or to a regional or national reliability organization. The Party asserting confidentiality shall notify the other ~~Party~~Parties in writing of the information it claims is confidential. Prior to any disclosures of ~~the other~~another Party's Confidential Information under this subparagraph, or if any third party or Governmental Authority makes any request or demand for any of the information described in this subparagraph, the disclosing Party agrees to promptly notify the other Party in writing and agrees to assert confidentiality and cooperate with the other Party in seeking to protect the Confidential Information from public disclosure by confidentiality agreement, protective order or other reasonable measures.

~~Article 23. — Environmental Releases~~

ARTICLE 23. ENVIRONMENTAL RELEASES

23.1 Each Party shall notify the other ~~Party~~Parties, first orally and then in writing, of the release of any Hazardous Substances, any asbestos or lead abatement activities, or any type of remediation activities related to the Large Generating Facility or the Interconnection Facilities, each of which may reasonably be expected to affect the other ~~Party~~Parties. The notifying Party shall: (i) provide the notice as soon as practicable, provided such Party makes a good faith effort to provide the notice no later than twenty-four hours after such Party becomes aware of the occurrence; and (ii) promptly furnish to the other ~~Party~~Parties copies

of any publicly available reports filed with any Governmental Authorities addressing such events.

~~Article 24. Information Requirements~~

ARTICLE 24. INFORMATION REQUIREMENTS

- 24.1 Information Acquisition.** ~~Transmission Provider~~ The Participating TO and the Interconnection Customer shall submit specific information regarding the electrical characteristics of their respective facilities to each other as described below and in accordance with Applicable Reliability Standards.
- 24.2 Information Submission by ~~Transmission Provider~~ Participating TO.** The initial information submission by ~~Transmission Provider~~ the Participating TO shall occur no later than one hundred eighty (180) Calendar Days prior to Trial Operation and shall include the Participating TO's Transmission System information necessary to allow the Interconnection Customer to select equipment and meet any system protection and stability requirements, unless otherwise agreed to by the ~~Parties~~ Participating TO and the Interconnection Customer. On a monthly basis ~~Transmission Provider~~ the Participating TO shall provide the Interconnection Customer and the CAISO a status report on the construction and installation of ~~Transmission Provider~~ the Participating TO's Interconnection Facilities and Network Upgrades, including, but not limited to, the following information: (1) progress to date; (2) a description of the activities since the last report; (3) a description of the action items for the next period; and (4) the delivery status of equipment ordered.
- 24.3 Updated Information Submission by Interconnection Customer.** The updated information submission by the Interconnection Customer, including manufacturer information, shall occur no later than one hundred eighty (180) Calendar Days prior to the Trial Operation. The Interconnection Customer shall submit a completed copy of the ~~Large Electric~~ Generating Facility Unit data requirements contained in Appendix 1 to the LGIP. It shall also include any additional information provided to ~~Transmission Provider for the Feasibility and Facilities Study~~ the Participating TO and the CAISO for the Interconnection Studies. Information in this submission shall be the most current ~~Large Electric~~ Generating Facility Unit design or expected performance data. Information submitted for stability models shall be compatible with ~~Transmission Provider~~ the Participating TO and CAISO standard models. If there is no compatible model, the Interconnection Customer will work with a consultant mutually agreed to by the Parties to develop and supply a standard model and associated information.

If the Interconnection Customer's data is materially different from what was originally provided to ~~Transmission Provider pursuant to the Participating TO and the CAISO for the Interconnection Study Agreement between Transmission Provider and Interconnection Customer, then Transmission Provider~~ Studies, then the Participating TO and the CAISO will conduct appropriate studies pursuant to the LGIP to

determine the impact on ~~Transmission Provider~~ the Participating TO's Transmission System and affected portions of the CAISO Controlled Grid based on the actual data submitted pursuant to this Article 24.3. The Interconnection Customer shall not begin Trial Operation until such studies are completed and all other requirements of this LGIA are satisfied.

24.4 Information Supplementation. Prior to the Trial Operation ~~Date~~ date, the Parties shall supplement their information submissions described above in this Article 24 with any and all "as-built" Large Electric Generating Facility Unit information or "as-tested" performance information that differs from the initial submissions or, alternatively, written confirmation that no such differences exist. The Interconnection Customer shall conduct tests on the Large Electric Generating Facility Unit as required by Good Utility Practice such as an open circuit "step voltage" test on the Large Electric Generating Facility Unit to verify proper operation of the Large Electric Generating Facility Unit's automatic voltage regulator.

Unless otherwise agreed, the test conditions shall include: (1) Large Electric Generating Facility Unit at synchronous speed; (2) automatic voltage regulator on and in voltage control mode; and (3) a five percent (5 percent) change in Large Electric Generating Facility Unit terminal voltage initiated by a change in the voltage regulators reference voltage. The Interconnection Customer shall provide validated test recordings showing the responses of Large Electric Generating Facility Unit terminal and field voltages. In the event that direct recordings of these voltages is impractical, recordings of other voltages or currents that mirror the response of the Large Electric Generating Facility Unit's terminal or field voltage are acceptable if information necessary to translate these alternate quantities to actual Large Electric Generating Facility Unit terminal or field voltages is provided. Large Electric Generating Facility Unit testing shall be conducted and results provided to ~~Transmission Provider~~ the Participating TO and the CAISO for each individual ~~generating unit~~ Electric Generating Unit in a station.

Subsequent to the Commercial Operation Date, the Interconnection Customer shall provide ~~Transmission Provider~~ the Participating TO and the CAISO any information changes due to equipment replacement, repair, or adjustment. ~~Transmission Provider~~ The Participating TO shall provide the Interconnection Customer any information changes due to equipment replacement, repair or adjustment in the directly connected substation or any adjacent ~~Transmission Provider~~ Participating TO-owned substation that may affect the Interconnection Customer's Interconnection Facilities equipment ratings, protection or operating requirements. The Parties shall provide such information ~~no later than thirty (30) Calendar Days after the date of the equipment replacement, repair or adjustment~~ pursuant to Article 5.19.

~~Article 25. Information Access and Audit Rights~~

ARTICLE 25. INFORMATION ACCESS AND AUDIT RIGHTS

- 25.1 Information Access.** Each Party (the “disclosing Party”) shall make available to the other Party information that is in the possession of the disclosing Party and is necessary in order for the other Party to: (i) verify the costs incurred by the disclosing Party for which the other Party is responsible under this LGIA; and (ii) carry out its obligations and responsibilities under this LGIA. The Parties shall not use such information for purposes other than those set forth in this Article 25.1 and to enforce their rights under this LGIA. Nothing in this Article 25 shall obligate the CAISO to make available to a Party any third party information in its possession or control if making such third party information available would violate a CAISO Tariff restriction on the use or disclosure of such third party information.
- 25.2 Reporting of Non-Force Majeure Events.** Each Party (the “notifying Party”) shall notify the other ~~Party~~Parties when the notifying Party becomes aware of its inability to comply with the provisions of this LGIA for a reason other than a Force Majeure event. The Parties agree to cooperate with each other and provide necessary information regarding such inability to comply, including the date, duration, reason for the inability to comply, and corrective actions taken or planned to be taken with respect to such inability to comply. Notwithstanding the foregoing, notification, cooperation or information provided under this ~~article~~Article shall not entitle the Party receiving such notification to allege a cause for anticipatory breach of this LGIA.
- 25.3 Audit Rights.** Subject to the requirements of confidentiality under Article 22 of this LGIA, ~~each Party shall have the right, during normal business hours, and upon prior reasonable notice to the other Party, to audit at its own expense the other Party's accounts and records pertaining to either Party's performance or either Party's~~the Parties' audit rights shall include audits of a Party's costs pertaining to such Party's performance or satisfaction of obligations under this LGIA. Such audit rights shall include audits of~~owed to the other Party's costs under this LGIA,~~owed to the other Party's ~~costs under this LGIA,~~ calculation of invoiced amounts, ~~Transmission Provider~~the CAISO's efforts to allocate responsibility for the provision of reactive support to the ~~Transmission System, Transmission Provider~~CAISO Controlled Grid, the CAISO's efforts to allocate responsibility for interruption or reduction of generation on the ~~Transmission System~~CAISO Controlled Grid, and each such Party's actions in an Emergency Condition. ~~Any~~
- 25.3.1** The Interconnection Customer and the Participating TO shall each have the right, during normal business hours, and upon prior reasonable notice to the other Party, to audit at its own expense the other Party's accounts and records pertaining to either such Party's performance or either such Party's satisfaction of obligations owed to the other Party under this LGIA. Subject to Article 25.3.2, any audit authorized by this ~~article~~Article shall be performed at the offices where such accounts and records are maintained and shall be limited to those portions of such accounts and records that

relate to each such Party's performance and satisfaction of obligations under this LGIA. Each such Party shall keep such accounts and records for a period equivalent to the audit rights periods described in Article 25.4.

25.3.2 Notwithstanding anything to the contrary in Article 25.3, each Party's rights to audit the CAISO's accounts and records shall be as set forth in Section 22.1 of the CAISO Tariff.

25.4 Audit Rights Periods.

25.4.1 Audit Rights Period for Construction-Related Accounts and Records.

Accounts and records related to the design, engineering, procurement, and construction of ~~Transmission Provider~~ Participating TO's Interconnection Facilities ~~and~~ Network Upgrades, and Distribution Upgrades constructed by the Participating TO shall be subject to audit for a period of twenty-four months following ~~Transmission Provider~~ the Participating TO's issuance of a final invoice in accordance with Article 12.2. Accounts and records related to the design, engineering, procurement, and construction of Participating TO's Interconnection Facilities and/or Stand Alone Network Upgrades constructed by the Interconnection Customer shall be subject to audit and verification by the Participating TO and the CAISO for a period of twenty-four months following the Interconnection Customer's issuance of a final invoice in accordance with Article 5.2(8).

25.4.2 Audit Rights Period for All Other Accounts and Records. Accounts and records related to ~~either~~ a Party's performance or satisfaction of all obligations under this LGIA other than those described in Article 25.4.1 shall be subject to audit as follows: (i) for an audit relating to cost obligations, the applicable audit rights period shall be twenty-four months after the auditing Party's receipt of an invoice giving rise to such cost obligations; and (ii) for an audit relating to all other obligations, the applicable audit rights period shall be twenty-four months after the event for which the audit is sought; provided that each Party's rights to audit the CAISO's accounts and records shall be as set forth in Section 22.1 of the CAISO Tariff.

25.5 Audit Results. If an audit by ~~a Party~~ the Interconnection Customer or the Participating TO determines that an overpayment or an underpayment has occurred with respect to the other Party, a notice of such overpayment or underpayment shall be given to the other Party together with those records from the audit which ~~support~~ supports such determination. The Party that is owed payment shall render an invoice to the other Party and such invoice shall be paid pursuant to Article 12 hereof.

25.5.1 Notwithstanding anything to the contrary in Article 25.5, the Interconnection Customer's and Participating TO's rights to audit the

CAISO's accounts and records shall be as set forth in Section 22.1 of the CAISO Tariff, and the CAISO's process for remedying an overpayment or underpayment shall be as set forth in the CAISO Tariff.

~~Article 26. — Subcontractors~~

ARTICLE 26. SUBCONTRACTORS

- 26.1 General.** Nothing in this LGIA shall prevent a Party from utilizing the services of any subcontractor as it deems appropriate to perform its obligations under this LGIA; provided, however, that each Party shall require its subcontractors to comply with all applicable terms and conditions of this LGIA in providing such services and each Party shall remain primarily liable to the other Party for the performance of such subcontractor.
- 26.2 Responsibility of Principal.** The creation of any subcontract relationship shall not relieve the hiring Party of any of its obligations under this LGIA. The hiring Party shall be fully responsible to the other ~~Party~~Parties for the acts or omissions of any subcontractor the hiring Party hires as if no subcontract had been made; provided, however, that in no event shall ~~Transmission Provider~~the CAISO or Participating TO be liable for the actions or inactions of the Interconnection Customer or its subcontractors with respect to obligations of the Interconnection Customer under Article 5 of this LGIA. Any applicable obligation imposed by this LGIA upon the hiring Party shall be equally binding upon, and shall be construed as having application to, any subcontractor of such Party.
- 26.3 No Limitation by Insurance.** The obligations under this Article 26 will not be limited in any way by any limitation of subcontractor's insurance.

~~Article 27. — Disputes~~

ARTICLE 27. DISPUTES

All disputes arising out of or in connection with this LGIA whereby relief is sought by or from the CAISO shall be settled in accordance with the provisions of Article 13 of the CAISO Tariff, except that references to the CAISO Tariff in such Article 13 of the CAISO Tariff shall be read as references to this LGIA. Disputes arising out of or in connection with this LGIA not subject to provisions of Article 13 of the CAISO Tariff shall be resolved as follows:

- 27.1 Submission.** In the event either Party has a dispute, or asserts a claim, that arises out of or in connection with this LGIA or its performance, such Party (the "disputing Party") shall provide the other Party with written notice of the dispute or claim ("Notice of Dispute"). Such dispute or claim shall be referred to a designated senior representative of each Party for resolution on an informal basis as promptly as practicable after receipt of the Notice of Dispute by the other Party. In the event the designated representatives are unable to resolve the

claim or dispute through unassisted or assisted negotiations within thirty (30) Calendar Days of the other Party's receipt of the Notice of Dispute, such claim or dispute may, upon mutual agreement of the Parties, be submitted to arbitration and resolved in accordance with the arbitration procedures set forth below. In the event the Parties do not agree to submit such claim or dispute to arbitration, each Party may exercise whatever rights and remedies it may have in equity or at law consistent with the terms of this LGIA.

- 27.2 External Arbitration Procedures.** Any arbitration initiated under this LGIA shall be conducted before a single neutral arbitrator appointed by the Parties. If the Parties fail to agree upon a single arbitrator within ten (10) Calendar Days of the submission of the dispute to arbitration, each Party shall choose one arbitrator who shall sit on a three-member arbitration panel. The two arbitrators so chosen shall within twenty (20) Calendar Days select a third arbitrator to chair the arbitration panel. In either case, the arbitrators shall be knowledgeable in electric utility matters, including electric transmission and bulk power issues, and shall not have any current or past substantial business or financial relationships with any party to the arbitration (except prior arbitration). The arbitrator(s) shall provide each of the Parties an opportunity to be heard and, except as otherwise provided herein, shall conduct the arbitration in accordance with the Commercial Arbitration Rules of the American Arbitration Association ("Arbitration Rules") and any applicable FERC regulations ~~or RTO rules~~; provided, however, in the event of a conflict between the Arbitration Rules and the terms of this Article 27, the terms of this Article 27 shall prevail.
- 27.3 Arbitration Decisions.** Unless otherwise agreed by the Parties, the arbitrator(s) shall render a decision within ninety (90) Calendar Days of appointment and shall notify the Parties in writing of such decision and the reasons therefor. The arbitrator(s) shall be authorized only to interpret and apply the provisions of this LGIA and shall have no power to modify or change any provision of this Agreement in any manner. The decision of the arbitrator(s) shall be final and binding upon the Parties, and judgment on the award may be entered in any court having jurisdiction. The decision of the arbitrator(s) may be appealed solely on the grounds that the conduct of the arbitrator(s), or the decision itself, violated the standards set forth in the Federal Arbitration Act or the Administrative Dispute Resolution Act. The final decision of the arbitrator(s) must also be filed with FERC if it affects jurisdictional rates, terms and conditions of service, Interconnection Facilities, or Network Upgrades.
- 27.4 Costs.** Each Party shall be responsible for its own costs incurred during the arbitration process and for the following costs, if applicable: (1) the cost of the arbitrator chosen by the Party to sit on the three member panel and one half of the cost of the third arbitrator chosen; or (2) one half the cost of the single arbitrator jointly chosen by the Parties.

~~Article 28. Representations, Warranties, and Covenants~~

ARTICLE 28. REPRESENTATIONS, WARRANTIES AND COVENANTS

28.1 General. Each Party makes the following representations, warranties and covenants:

- 28.1.1 Good Standing.** Such Party is duly organized, validly existing and in good standing under the laws of the state in which it is organized, formed, or incorporated, as applicable; that it is qualified to do business in the state or states in which the Large Generating Facility, Interconnection Facilities and Network Upgrades owned by such Party, as applicable, are located; and that it has the corporate power and authority to own its properties, to carry on its business as now being conducted and to enter into this LGIA and carry out the transactions contemplated hereby and perform and carry out all covenants and obligations on its part to be performed under and pursuant to this LGIA.
- 28.1.2 Authority.** Such Party has the right, power and authority to enter into this LGIA, to become a Party hereto and to perform its obligations hereunder. This LGIA is a legal, valid and binding obligation of such Party, enforceable against such Party in accordance with its terms, except as the enforceability thereof may be limited by applicable bankruptcy, insolvency, reorganization or other similar laws affecting creditors' rights generally and by general equitable principles (regardless of whether enforceability is sought in a proceeding in equity or at law).
- 28.1.3 No Conflict.** The execution, delivery and performance of this LGIA does not violate or conflict with the organizational or formation documents, or bylaws or operating agreement, of such Party, or any judgment, license, permit, order, material agreement or instrument applicable to or binding upon such Party or any of its assets.
- 28.1.4 Consent and Approval.** Such Party has sought or obtained, or, in accordance with this LGIA will seek or obtain, each consent, approval, authorization, order, or acceptance by any Governmental Authority in connection with the execution, delivery and performance of this LGIA, and it will provide to any Governmental Authority notice of any actions under this LGIA that are required by Applicable Laws and Regulations.

~~Article 29. — Joint Operating Committee~~

~~ARTICLE 29. [RESERVED]~~

~~29.1 — Joint Operating Committee. Except in the case of ISOs and RTOs, Transmission Provider shall constitute a Joint Operating Committee to coordinate operating and technical considerations of Interconnection Service. At least six (6) months prior to the expected Initial Synchronization Date, Interconnection Customer and Transmission Provider shall each appoint one representative and one alternate to the Joint Operating Committee. Each Interconnection Customer shall notify Transmission Provider of its appointment in writing. Such appointments may be changed at any time by similar notice. The Joint Operating Committee shall meet as necessary, but not less than once each calendar year, to carry out the duties set forth herein. The Joint Operating Committee shall hold a meeting at the request of either Party, at a time and place agreed upon by the representatives. The Joint Operating Committee shall perform all of its duties consistent with the provisions of this LGIA. Each Party shall cooperate in providing to the Joint Operating Committee all information required in the performance of the Joint Operating Committee's duties. All decisions and agreements, if any, made by the Joint Operating Committee, shall be evidenced in writing. The duties of the Joint Operating Committee shall include the following:~~

- ~~———— 29.1.1 Establish data requirements and operating record requirements.~~
- ~~———— 29.1.2 Review the requirements, standards, and procedures for data acquisition equipment, protective equipment, and any other equipment or software.~~
- ~~———— 29.1.3 Annually review the one (1) year forecast of maintenance and planned outage schedules of Transmission Provider's and Interconnection Customer's facilities at the Point of Interconnection.~~
- ~~———— 29.1.4 Coordinate the scheduling of maintenance and planned outages on the Interconnection Facilities, the Large Generating Facility and other facilities that impact the normal operation of the interconnection of the Large Generating Facility to the Transmission System.~~
- ~~———— 29.1.5 Ensure that information is being provided by each Party regarding equipment availability.~~
- ~~———— 29.1.6 Perform such other duties as may be conferred upon it by mutual agreement of the Parties.~~

~~Article 30. — Miscellaneous~~

~~ARTICLE 30. MISCELLANEOUS~~

~~30.1 **Binding Effect.** This LGIA and the rights and obligations hereof, shall be binding upon and shall inure to the benefit of the successors and assigns of the Parties hereto.~~

~~30.2 **Conflicts.** In the event of a conflict between the body of this LGIA and any attachment, appendices or exhibits hereto, the terms and provisions of the body of this LGIA shall prevail and be deemed the final intent of the Parties.~~

- 30.3 Rules of Interpretation.** This LGIA, unless a clear contrary intention appears, shall be construed and interpreted as follows: (1) the singular number includes the plural number and vice versa; (2) reference to any person includes such person's successors and assigns but, in the case of a Party, only if such successors and assigns are permitted by this LGIA, and reference to a person in a particular capacity excludes such person in any other capacity or individually; (3) reference to any agreement (including this LGIA), document, instrument or tariff means such agreement, document, instrument, or tariff as amended or modified and in effect from time to time in accordance with the terms thereof and, if applicable, the terms hereof; (4) reference to any Applicable Laws and Regulations means such Applicable Laws and Regulations as amended, modified, codified, or reenacted, in whole or in part, and in effect from time to time, including, if applicable, rules and regulations promulgated thereunder; (5) unless expressly stated otherwise, reference to any Article, Section or Appendix means such Article of this LGIA or such Appendix to this LGIA, or such Section to the LGIP or such Appendix to the LGIP, as the case may be; (6) "hereunder", "hereof", "herein", "hereto" and words of similar import shall be deemed references to this LGIA as a whole and not to any particular Article or other provision hereof or thereof; (7) "including" (and with correlative meaning "include") means including without limiting the generality of any description preceding such term; and (8) relative to the determination of any period of time, "from" means "from and including", "to" means "to but excluding" and "through" means "through and including".
- 30.4 Entire Agreement.** This LGIA, including all Appendices and Schedules attached hereto, constitutes the entire agreement ~~between~~among the Parties with reference to the subject matter hereof, and supersedes all prior and contemporaneous understandings or agreements, oral or written, ~~between~~or among the Parties with respect to the subject matter of this LGIA. There are no other agreements, representations, warranties, or covenants which constitute any part of the consideration for, or any condition to, ~~either~~any Party's compliance with its obligations under this LGIA.
- 30.5 No Third Party Beneficiaries.** This LGIA is not intended to and does not create rights, remedies, or benefits of any character whatsoever in favor of any persons, corporations, associations, or entities other than the Parties, and the obligations herein assumed are solely for the use and benefit of the Parties, their successors in interest and, where permitted, their assigns.
- 30.6 Waiver.** The failure of a Party to this LGIA to insist, on any occasion, upon strict performance of any provision of this LGIA will not be considered a waiver of any obligation, right, or duty of, or imposed upon, such Party.

Any waiver at any time by either Party of its rights with respect to this LGIA shall not be deemed a continuing waiver or a waiver with respect to any other failure to comply with any other obligation, right, duty of this LGIA. Termination or Default

of this LGIA for any reason by the Interconnection Customer shall not constitute a waiver of the Interconnection Customer's legal rights to obtain an interconnection from ~~Transmission Provider~~the Participating TO. Any waiver of this LGIA shall, if requested, be provided in writing.

- 30.7 Headings.** The descriptive headings of the various Articles of this LGIA have been inserted for convenience of reference only and are of no significance in the interpretation or construction of this LGIA.
- 30.8 Multiple Counterparts.** This LGIA may be executed in two or more counterparts, each of which is deemed an original but all constitute one and the same instrument.
- 30.9 Amendment.** The Parties may by mutual agreement amend this LGIA by a written instrument duly executed by ~~the Parties~~all of the Parties. Such amendment shall become effective and a part of this LGIA upon satisfaction of all Applicable Laws and Regulations.
- 30.10 Modification by the Parties.** The Parties may by mutual agreement amend the Appendices to this LGIA by a written instrument duly executed by all of the Parties. Such amendment shall become effective and a part of this LGIA upon satisfaction of all Applicable Laws and Regulations.
- 30.11 Reservation of Rights.** ~~Transmission Provider~~The CAISO and Participating TO shall each have the right to make a unilateral filing with FERC to modify this LGIA ~~with respect to any rates, terms and conditions, charges, classifications of service, rule or regulation under~~pursuant to section 205 or any other applicable provision of the Federal Power Act and FERC's rules and regulations thereunder, ~~and with~~ respect to the following Articles and Appendices of this LGIA and with respect to any rates, terms and conditions, charges, classifications of service, rule or regulation covered by these Articles and Appendices:

Recitals, 1, 2.1, 2.2, 2.3, 2.4, 2.6, 3.1, 3.3, 4.1, 4.2, 4.3, 4.4, 5 preamble, 5.4, 5.7, 5.8, 5.9, 5.12, 5.13, 5.18, 5.19.1, 7.1, 7.2, 8, 9.1, 9.2, 9.3, 9.5, 9.6, 9.7, 9.8, 9.10, 10.3, 11.4, 12.1, 13, 14, 15, 16, 17, 18, 19, 20, 21, 22, 23, 24.3, 24.4, 25.1, 25.2, 25.3 (excluding subparts), 25.4.2, 26, 28, 29, 30, Appendix D, Appendix F, Appendix G, and any other Article not reserved exclusively to the Participating TO or the CAISO below.

The Participating TO shall have the exclusive right to make a unilateral filing with FERC to modify this LGIA pursuant to section 205 or any other applicable provision of the Federal Power Act and FERC's rules and regulations thereunder with respect to the following Articles and Appendices of this LGIA and with respect to any rates, terms and conditions, charges, classifications of service, rule or regulation covered by these Articles and Appendices:

2.5, 5.1, 5.2, 5.3, 5.5, 5.6, 5.10, 5.11, 5.14, 5.15, 5.16, 5.17, 5.19 (excluding 5.19.1), 6, 7.3, 9.4, 9.9, 10.1, 10.2, 10.4, 10.5, 11.1, 11.2, 11.3, 11.5, 12.2, 12.3, 12.4, 24.1, 24.2, 25.3.1, 25.4.1, 25.5 (excluding 25.5.1), 27 (excluding preamble), Appendix A, Appendix B, Appendix C, and Appendix E.

The CAISO shall have the exclusive right to make a unilateral filing with FERC to modify this LGIA pursuant to section 205 or any other applicable provision of the Federal Power Act and FERC's rules and regulations thereunder with respect to the following Articles of this LGIA and with respect to any rates, terms and conditions, charges, classifications of service, rule or regulation covered by these Articles:

3.2, 4.5, 11.6, 25.3.2, 25.5.1, and 27 preamble.

The Interconnection Customer, the CAISO, and the Participating TO shall have the right to make a unilateral filing with FERC to modify this LGIA pursuant to section 206 or any other applicable provision of the Federal Power Act and FERC's rules and regulations thereunder; provided that each Party shall have the right to protest any such filing by ~~the other~~another Party and to participate fully in any proceeding before FERC in which such modifications may be considered. Nothing in this LGIA shall limit the rights of the Parties or of FERC under sections 205 or 206 of the Federal Power Act and FERC's rules and regulations thereunder, except to the extent that the Parties otherwise mutually agree as provided herein.

30.12 No Partnership. This LGIA shall not be interpreted or construed to create an association, joint venture, agency relationship, or partnership ~~between~~among the Parties or to impose any partnership obligation or partnership liability upon ~~either~~any Party. ~~Neither~~No Party shall have any right, power or authority to enter into any agreement or undertaking for, or act on behalf of, or to act as or be an agent or representative of, or to otherwise bind, ~~the other~~another Party.

30.13 Joint and Several Obligations. Except as otherwise provided in this LGIA, the obligations of the CAISO, the Participating TO, and the Interconnection Customer are several, and are neither joint nor joint and several.

IN WITNESS WHEREOF, the Parties have executed this LGIA in ~~duplicate~~multiple originals, each of which shall constitute and be an original effective ~~Agreement~~ agreement among the Parties.

~~[Insert name of Transmission Provider or Transmission Owner, if applicable]~~

By: _____ By: _____

Title: _____ Title: _____

Date: _____ Date: _____

[Insert name of Interconnection Customer]

By: _____

Title: _____

Date: _____

[Insert name of Participating TO]

By: _____

Title: _____

Date: _____

California Independent System Operator Corporation

By: _____

Title: _____

Date: _____

Appendices to LGIA

[Appendix A Interconnection Facilities, Network Upgrades and Distribution Upgrades](#)

[Appendix B Milestones](#)

[Appendix C Interconnection Details](#)

[Appendix D Security Arrangements Details](#)

[Appendix E Commercial Operation Date](#)

[Appendix F Addresses for Delivery of Notices and Billings](#)

[Appendix G Interconnection Customer's Proportional Share of Costs of Network Upgrades for Applicable Project Group](#)

[Appendix H Interconnection Requirements for a Wind Generating Plant](#)

**Appendix A~~to~~
To LGIA**

Interconnection Facilities, Network Upgrades and Distribution Upgrades

1. Interconnection Facilities:

(a) [insert Interconnection Customer's Interconnection Facilities]:

(b) [insert ~~Transmission Provider~~ Participating TO's Interconnection Facilities]:

2. Network Upgrades:

(a) [insert Stand Alone Network Upgrades]:

(b) [insert Other Network Upgrades]:

(i) [insert Participating TO's Reliability Network Upgrades]

(ii) [insert Participating TO's Delivery Network Upgrades]

3. Distribution Upgrades:

Appendix B
To LGIA
Milestones

Appendix C ~~to~~
To LGIA

Interconnection Details

**Appendix D ~~to~~
To LGIA**

Security Arrangements Details

Infrastructure security of ~~Transmission System~~ CAISO Controlled Grid equipment and operations and control hardware and software is essential to ensure day-to-day ~~Transmission System~~ CAISO Controlled Grid reliability and operational security. FERC will expect the CAISO, all ~~Transmission Providers~~ Participating TOs, market participants, and Interconnection Customers interconnected to the ~~Transmission System~~ CAISO Controlled Grid to comply with the recommendations offered by the President's Critical Infrastructure Protection Board and, eventually, best practice recommendations from the electric reliability authority. All public utilities will be expected to meet basic standards for system infrastructure and operational security, including physical, operational, and cyber-security practices.

The Interconnection Customer shall meet the requirements for security implemented pursuant to the CAISO Tariff, including the CAISO's standards for information security posted on the CAISO's internet web site at the following internet address: <http://www.caiso.com/pubinfo/info-security/index.html>.

Appendix E ~~to~~
To LGIA

Commercial Operation Date

[This Appendix E ~~is~~ sets forth a ~~part~~ form of letter to be provided by the LGIA between Transmission Provider and Interconnection Customer to the CAISO and Participating TO to provide formal notice of the Commercial Operation of an Electric Generating Unit.]

[Date]

~~[Transmission Provider]~~ [CAISO Address]

[Participating TO Address]

Re: _____ ~~Large~~ Electric Generating ~~Facility~~ Unit

Dear _____:

On [Date] [Interconnection Customer] has completed Trial Operation of Unit No. _____. This letter confirms that [Interconnection Customer] commenced Commercial Operation of Unit No. _____ at the ~~Large~~ Electric Generating ~~Facility~~ Unit, effective as of **[Date plus one day]** and that [Interconnection Customer] provided the CAISO's operations personnel advance notice of its intended Commercial Operation Date no less than five Business Days prior to that date.

Thank you.

[Signature]

[Interconnection Customer Representative]

Appendix F ~~to~~
To LGIA

Addresses for Delivery of Notices and Billings

Notices:-

Participating TO:

~~Transmission Provider:~~

[To be supplied.]

Interconnection Customer:

[To be supplied.]

CAISO:

[To be supplied.]

Billings and Payments:

~~Transmission Provider:~~

Participating TO:

[To be supplied.]

Interconnection Customer:

[To be supplied.]

CAISO:

[To be supplied.]

Alternative Forms of Delivery of Notices (telephone, facsimile or ~~email~~[e-mail](#)):

~~Transmission Provider:~~

[Participating TO:](#)

[To be supplied.]

Interconnection Customer:

[To be supplied.]

[CAISO:](#)

[\[To be supplied.\]](#)

Appendix G-~~to~~
To LGIA

~~Interconnection Requirements for a Wind Generating Plant~~
Interconnection Customer's Proportional Share of Costs of Network Upgrades for
Applicable Project Group

Appendix H To LGIA

INTERCONNECTION REQUIREMENTS FOR A WIND GENERATING PLANT

Appendix H sets forth requirements and provisions specific to a wind generating plant. All other requirements of this LGIA continue to apply to wind generating plant interconnections.

A. Technical Standards Applicable to a Wind Generating Plant

i. Low Voltage Ride-Through (LVRT) Capability

A wind generating plant shall be able to remain online during voltage disturbances up to the time periods and associated voltage levels set forth in the standard below. ~~The LVRT standard provides for a transition period standard and a post-transition period standard.~~

~~Transition Period LVRT Standard~~

~~The transition period standard applies to wind generating plants subject to FERC Order 661 that have either: (i) interconnection agreements signed and filed with the Commission, filed with the Commission in unexecuted form, or filed with the Commission as non-conforming agreements between January 1, 2006 and December 31, 2006, with a scheduled in-service date no later than December 31, 2007, or (ii) wind generating turbines subject to a wind turbine procurement contract executed prior to December 31, 2005, for delivery through 2007.~~

- ~~1. Wind generating plants are required to remain in-service during three-phase faults with normal clearing (which is a time period of approximately 4–9 cycles) and single line to ground faults with delayed clearing, and subsequent post-fault voltage recovery to pre-fault voltage unless clearing the fault effectively disconnects the generator from the system. The clearing time requirement for a three-phase fault will be specific to the wind generating plant substation location, as determined by and documented by the transmission provider. The maximum clearing time the wind generating plant shall be required to withstand for a three-phase fault shall be 9 cycles at a voltage as low as 0.15 p.u., as measured at the high side of the wind generating plant step-up transformer (i.e. the transformer that steps the voltage up to the transmission interconnection voltage or “GSU”), after which, if the fault remains following the location-specific normal clearing time for three-phase faults, the wind generating plant may disconnect from the transmission system.~~
- ~~2. This requirement does not apply to faults that would occur between the wind generator terminals and the high side of the GSU or to faults that would result in a voltage lower than 0.15 per unit on the high side of the GSU serving the facility.~~
- ~~3. Wind generating plants may be tripped after the fault period if this action is intended as part of a special protection system.~~
- ~~4. Wind generating plants may meet the LVRT requirements of this standard by the performance of the generators or by installing additional equipment (e.g., Static VAR Compensator, etc.) within the wind generating plant or by a combination of generator performance and additional equipment.~~

- ~~5. Existing individual generator units that are, or have been, interconnected to the network at the same location at the effective date of the Appendix G LVRT Standard are exempt from meeting the Appendix G LVRT Standard for the remaining life of the existing generation equipment. Existing individual generator units that are replaced are required to meet the Appendix G LVRT Standard.~~

Post-transition Period LVRT Standard

All wind generating plants subject to FERC Order No. 661 ~~and not covered by the transition period described above~~ must meet the following requirements:

1. Wind generating plants are required to remain in-service during three-phase faults with normal clearing (which is a time period of approximately 4 – 9 cycles) and single line to ground faults with delayed clearing, and subsequent post-fault voltage recovery to prefault voltage unless clearing the fault effectively disconnects the generator from the system. The clearing time requirement for a three-phase fault will be specific to the wind generating plant substation location, as determined by and documented by the ~~transmission provider~~ Participating TO. The maximum clearing time the wind generating plant shall be required to withstand for a three-phase fault shall be 9 cycles after which, if the fault remains following the location-specific normal clearing time for three-phase faults, the wind generating plant may disconnect from the ~~transmission system~~ CAISO Controlled Grid. A wind generating plant shall remain interconnected during such a fault on the ~~transmission system~~ CAISO Controlled Grid for a voltage level as low as zero volts, as measured at the high voltage side of the wind GSU.
2. This requirement does not apply to faults that would occur between the wind generator terminals and the high side of the GSU.
3. Wind generating plants may be tripped after the fault period if this action is intended as part of a special protection system.
4. Wind generating plants may meet the LVRT requirements of this standard by the performance of the generators or by installing additional equipment (e.g., Static VAr Compensator) within the wind generating plant or by a combination of generator performance and additional equipment.
5. Existing individual generator units that are, or have been, interconnected to the ~~network~~ CAISO Controlled Grid at the same location at the effective date of the Appendix ~~G~~ H LVRT Standard are exempt from meeting the Appendix ~~G~~ H LVRT Standard for the remaining life of the existing generation equipment. Existing individual generator units that are replaced are required to meet the Appendix ~~G~~ H LVRT Standard.

ii. Power Factor Design Criteria (Reactive Power)

A wind generating plant shall ~~maintain~~operate within a power factor within the range of 0.95 leading to 0.95 lagging, measured at the Point of Interconnection as defined in this LGIA, ~~if the Transmission Provider's System Impact~~ in order to maintain a specified voltage schedule, if the Phase II Interconnection Study shows that such a requirement is necessary to ensure safety or reliability. The power factor range standard can be met by using, for example, power electronics designed to supply this level of reactive capability (taking into account any limitations due to voltage level, real power output, etc.) or fixed and switched capacitors ~~if agreed to by the Transmission Provider~~, or a combination of the two, if agreed to by the Participating TO and CAISO. The Interconnection Customer shall not disable power factor equipment while the wind plant is in operation. Wind plants shall also be able to provide sufficient dynamic voltage support in lieu of the power system stabilizer and automatic voltage regulation at the generator excitation system if the ~~System Impact~~ Phase II Interconnection Study shows this to be required for system safety or reliability.

iii. Supervisory Control and Data Acquisition (SCADA) Capability

The wind plant shall provide SCADA capability to transmit data and receive instructions from the ~~Transmission Provider~~ Participating TO and CAISO to protect system reliability. ~~The Transmission Provider~~ The Participating TO and CAISO and the wind plant Interconnection Customer shall determine what SCADA information is essential for the proposed wind plant, taking into account the size of the plant and its characteristics, location, and importance in maintaining generation resource adequacy and transmission system reliability in its area.

Appendix H To LGIA

Reliability Management System

1. ~~Definitions:~~

- ~~1.1 **Member:** Any party to the WECC Agreement.~~
- ~~1.2 **Reliability Management System or RMS:** The contractual reliability management program implemented through the WECC Reliability Criteria Agreement, Section 2 of this Appendix H, and any similar contractual arrangement.~~
- ~~1.3 **Western Interconnection:** The area comprising those states and provinces, or portions thereof, in Western Canada, Northern Mexico and the Western United States in which Members of the WECC operate synchronously connected transmission systems.~~
- ~~1.4 **WECC:** The Western Electricity Coordinating Council or any successor entity.~~
- ~~1.5 **WECC Agreement:** The Western Electricity Coordinating Council Agreement dated March 20, 1967, as such may be amended from time to time.~~
- ~~1.6 **WECC Reliability Criteria Agreement:** The Western Electricity Coordinating Council Reliability Criteria Agreement among the WECC and certain of its member Transmission Providers, as such may be amended from time to time.~~
- ~~1.7 **WECC Staff:** Those employees of the WECC, including personnel hired by the WECC on a contract basis, designated as responsible for the administration of the RMS.~~

2. ~~Terms and Conditions~~

- ~~2.1 **Purpose.** In order to maintain the reliable operation of the transmission grid, the WECC Reliability Criteria Agreement sets forth reliability criteria adopted by the WECC to which Interconnection Customer and Transmission Provider shall be required to comply.~~
- ~~2.2 **Compliance.** Interconnection Customer shall comply with the requirements of the WECC Reliability Criteria Agreement, including the applicable WECC reliability criteria set forth in Section IV of Annex A thereof, and, in the event of failure to comply, agrees to be subject to the sanctions applicable to such failure. Such sanctions shall be assessed pursuant to the procedures contained in the WECC Reliability Criteria Agreement. Each and all of the provisions of the WECC Reliability Criteria Agreement are hereby incorporated by reference into this Appendix H as though set forth fully herein, and Interconnection Customer shall for all purposes be considered a Participant, and shall be entitled to all of the rights and privileges and be subject to all of the obligations of a Participant, under and in connection with the WECC Reliability Criteria Agreement, including but not limited to the rights, privileges and obligations set forth in Sections 5, 6 and 10 of the WECC Reliability Criteria Agreement.~~
- ~~2.3 **Payment and Sanctions.** Interconnection Customer shall be responsible for reimbursing Transmission Provider for any monetary sanctions assessed against Transmission Provider due to the action or inaction of Interconnection Customer, by WECC pursuant to the WECC Reliability Criteria Agreement. Interconnection Customer also shall be responsible for payment of any~~

~~monetary sanction assessed against Interconnection Customer by WECC pursuant to the WECC Reliability Criteria Agreement. Any such payment shall be made pursuant to the procedures specified in the WECC Reliability Criteria Agreement.~~

~~**2.4 — Transfer of Control or Sale of Generation Facilities.** In any sale or transfer of control of any generation facilities subject to this Agreement, Interconnection Customer shall as a condition of such sale or transfer require the acquiring party or transferee with respect to the transferred facilities either to assume the obligations of Interconnection Customer with respect to this Agreement or to enter into an agreement with Transmission Provider imposing on the acquiring party or transferee the same obligations applicable to Interconnection Customer pursuant to this Appendix G.~~

~~**2.5 — Publication.** Interconnection Customer consents to the release by the WECC of information related to Interconnection Customer's compliance with this Agreement only in accordance with the WECC Reliability Criteria Agreement.~~

~~**2.6 — Third Parties.** Except for the rights and obligations between the WECC and Interconnection Customer specified in this Appendix H, this Agreement creates contractual rights and obligations solely between the Parties. Nothing in this Agreement shall create, as between the Parties or with respect to the WECC: (a) any obligation or liability whatsoever (other than as expressly provided in this Agreement), or (b) any duty or standard of care whatsoever. In addition, nothing in this Agreement shall create any duty, liability, or standard of care whatsoever as to any other party. Except for the rights, as a third party beneficiary under this Appendix H, of the WECC against Interconnection Customer, no third party shall have any rights whatsoever with respect to enforcement of any provision of this Agreement. Transmission Provider and Interconnection Customer expressly intend that the WECC is a third party beneficiary to this Appendix H, and the WECC shall have the right to seek to enforce against Interconnection Customer any provision of this Appendix H, provided that specific performance shall be the sole remedy available to the WECC pursuant to Appendix H of this Agreement, and Interconnection Customer shall not be liable to the WECC pursuant to this Agreement for damages of any kind whatsoever (other than the payment of sanctions to the WECC, if so construed), whether direct, compensatory, special, indirect, consequential, or punitive.~~

~~**2.7 — Reserved Rights.** Nothing in the RMS or the WECC Reliability Criteria Agreement shall affect the right of Transmission Provider, subject to any necessary regulatory approval, to take such other measures to maintain reliability, including disconnection, that Transmission Provider may otherwise be entitled to take.~~

~~**2.8 — Severability.** If one or more provisions of this Appendix H shall be invalid, illegal or unenforceable in any respect, it shall be given effect to the extent permitted by applicable law, and such invalidity, illegality or unenforceability shall not affect the validity of the other provisions of this Agreement.~~

~~**2.9 — Termination.** Interconnection Customer may terminate its obligations pursuant to this Appendix G:~~

~~(a) — If after the effective date of this Appendix H, the requirements of the WECC Reliability Criteria Agreement applicable to Interconnection Customer are amended so as to adversely affect Interconnection Customer, provided that Interconnection Customer gives fifteen (15) days' notice of such termination to Transmission Provider and WECC within forty five (45) days of the date of issuance of a Commission order accepting such~~

~~amendment for filing, provided further that the forty five (45) day period within which notice of termination is required may be extended by Interconnection Customer for an additional forty five (45) days if Interconnection Customer gives written notice to Transmission Provider of such requested extension within the initial forty five (45) day period; or~~

~~(b) — For any reason on one year's written notice to Transmission Provider and the WECC.~~

~~**2.10 — Mutual Agreement.** This Appendix H may be terminated at any time by mutual agreement of Transmission Provider and Interconnection Customer.~~

CERTIFICATE OF SERVICE

I hereby certify that I have this day served the foregoing document upon each person listed below.

Dated at Washington, D.C. this 28th day of May, 2010.

Michael Keegan
Morgan, Lewis & Bockius LLP
1111 Pennsylvania Avenue, N.W.
Washington, D.C. 20004

Service List

Arizona Corporation Commission

Steven Olea, Director, Utilities Division
Arizona Corporation Commission
1220 W. Washington St.
Phoenix, AZ 85007

California Public Utilities Commission

Arocles Aguilar
California Public Utilities Commission
505 Van Ness Ave.
San Francisco, CA 94102
aro@cpuc.ca.gov

Imperial Irrigation District

Stephen J. Keene
Imperial Irrigation District
333 E. Barioni Boulevard
Imperial, CA 92241
sjkeene@iid.com

Deborah Swanstrom
Patton Boggs LLP
2550 M Street, NW
Washington, DC 20037
dswanstrom@pattonboggs.com

Interconnection Customer

William D. Kissinger
Monica A. Schwebs
Bingham McCutchen LLP
Three Embarcadero Center
San Francisco, CA 94111-4067
william.kissinger@bingham.com
monica.schwebs@bingham.com