



California ISO
Shaping a Renewed Future

2014 and 2018 Final LCR Study Results - Fresno and Kern

Joseph E Meier

Senior Regional Transmission Engineer

Stakeholder Meeting

March 7, 2013

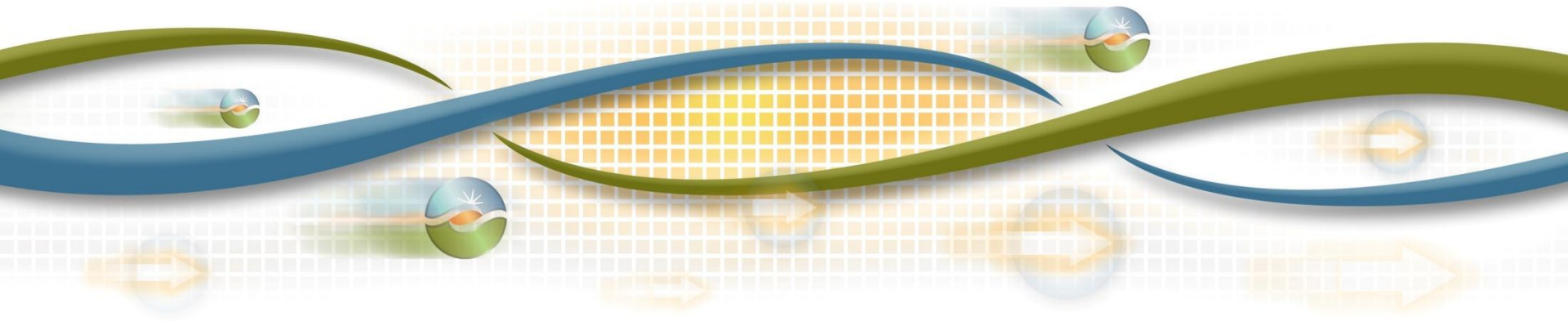

Fresno and Kern LCR Areas

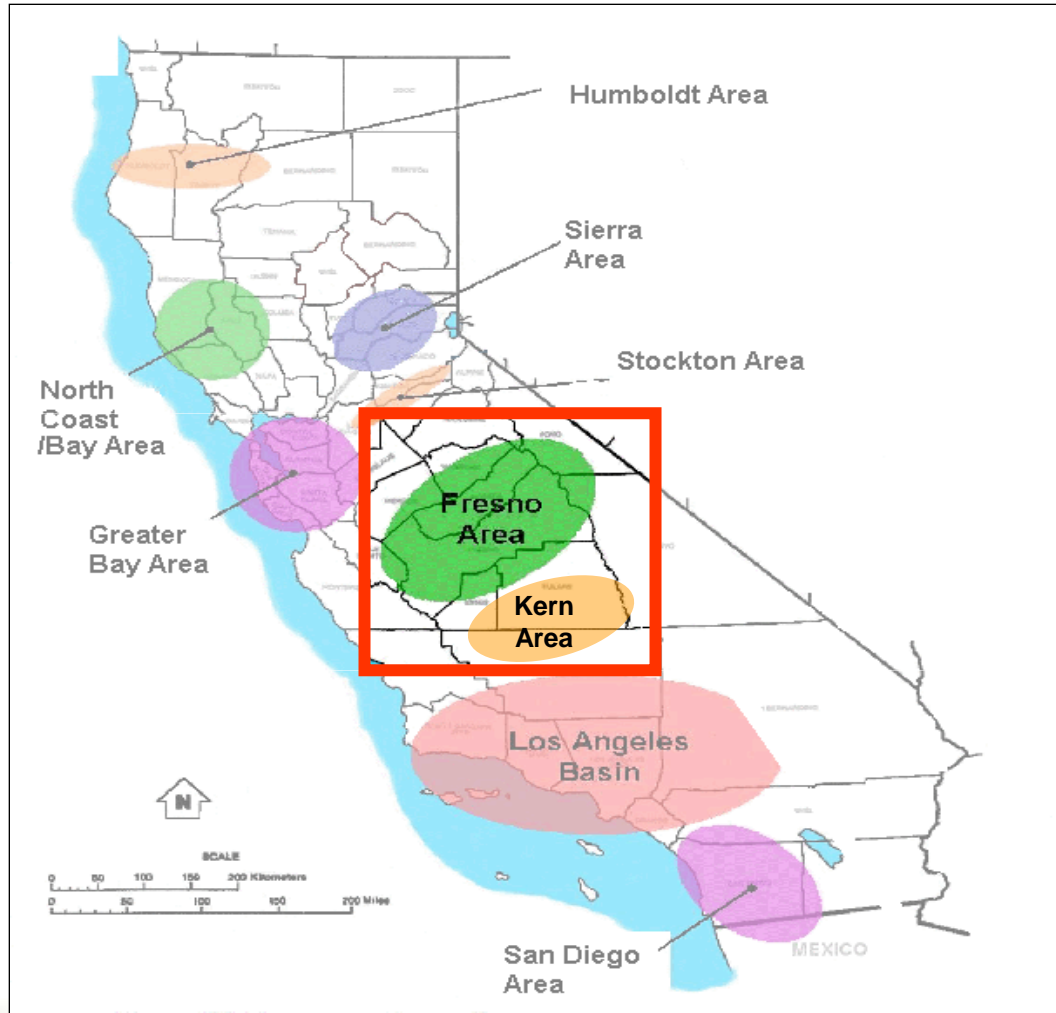

Kern Area Overview

Area Generation, Load and Transmission

Kern LCR Area

Total Generation and Load for 2014:

- **Generation (NQC plus new unit): 584**
- **Load (1-in-10 Summer-Peak): 1281 MW**

Total Generation and Load for 2018:

- **Generation (NQC plus new unit): 584**
- **Load (1-in-10 Summer-Peak): 1324 MW**

Kern Area LCR

2014 Kern PP Sub-Area

Limiting Contingencies:

Category B:

- L-1/G-1: Smyrna-Semitropic-Midway 115kV & Mt Poso generation
- Constraint: Midway-Semitropic 115kV

Category C:

- T-1/L-1: Smyrna-Semitropic-Midway 115kV & Kern PP #3 230/115kV
- Constraint: Midway-Semitropic 115kV

LCR Results (MW):

Contingency	Cat. B	Cat. C
LCR	293	329

Including:

QF	277	329
Muni	0	0
Deficiency	16	0

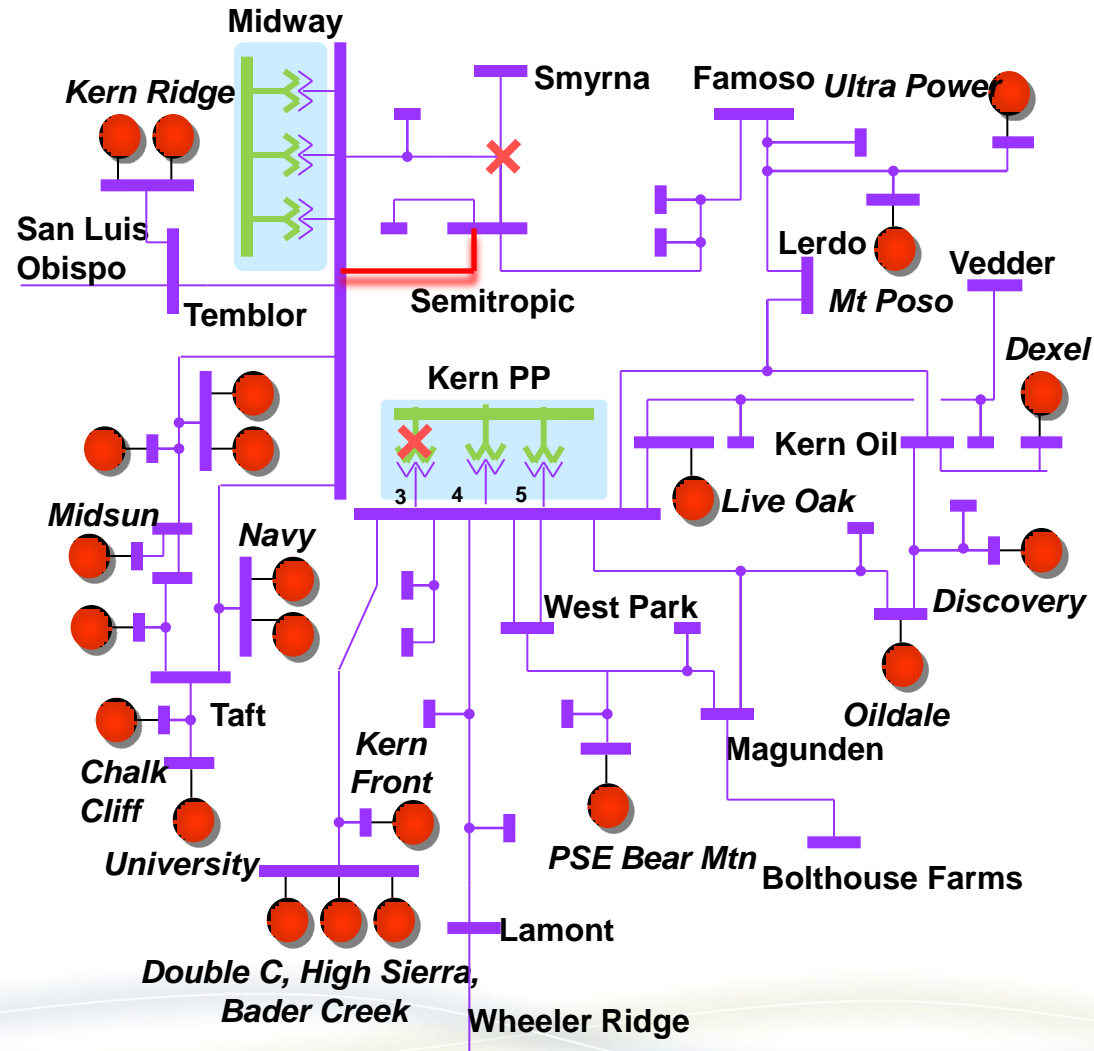

Kern Area LCR

2014 West Park Sub-Area

Limiting Contingencies:

Category B:

- None

Category C5:

- L-2: Kern West Park # 1 & #2 115kV
- Constraint: Kern-Magunden-Witco 115kV

LCR Results (MW):

Contingency	Cat. B	Cat. C
LCR	0	76

Including:

QF	44	44
Muni	0	0
Deficiency	0	32

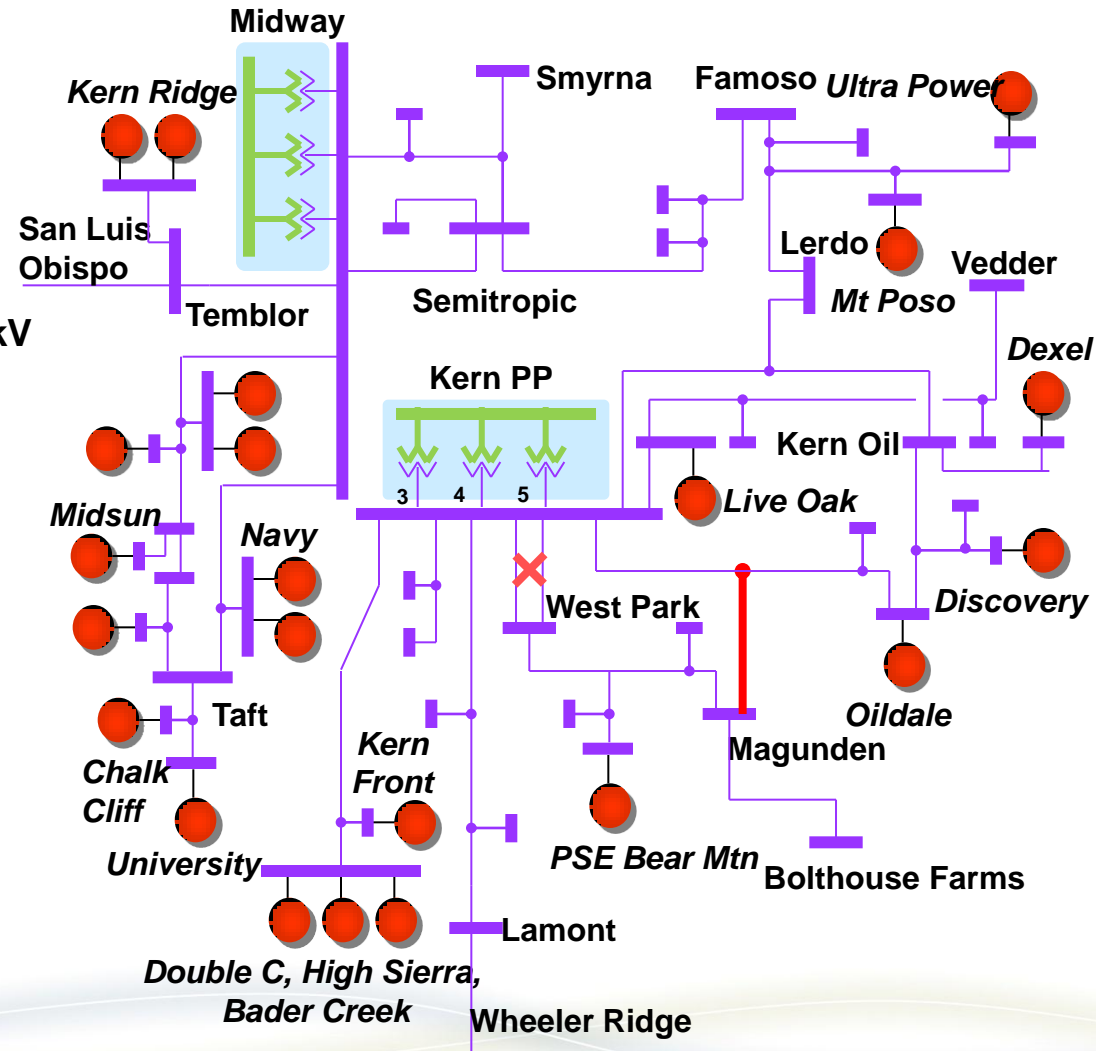

Kern Area LCR

Summary of 2014 LCR

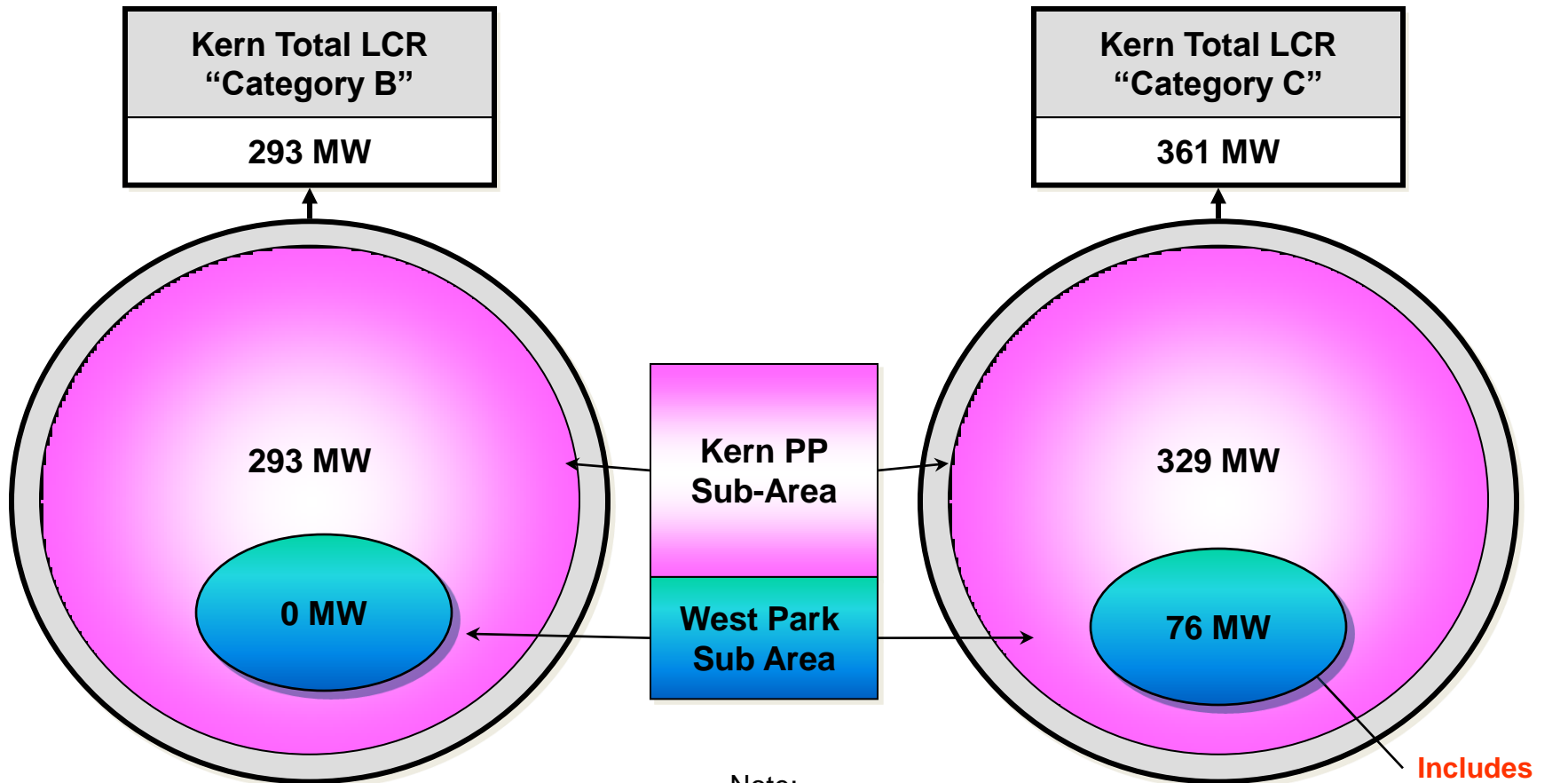

Note:

In the Kern area, due to overlapping of LCR sub-areas, the "Kern Total LCR" is *not* a simple sum, but rather an aggregated sum of LCR in individual sub-areas.

**Includes
32 MW
deficiency**

Kern Area LCR

2018 West Park Sub-Area

Limiting Contingencies:

Category B:

- None

Category C5:

- L-2: Kern West Park # 1 & #2 115kV
- Constraint: Kern-Magunden-Witco 115kV

LCR Results (MW):

Contingency	Cat. B	Cat. C
LCR	0	76

Including:

QF	44	44
Muni	0	0
Deficiency	0	32

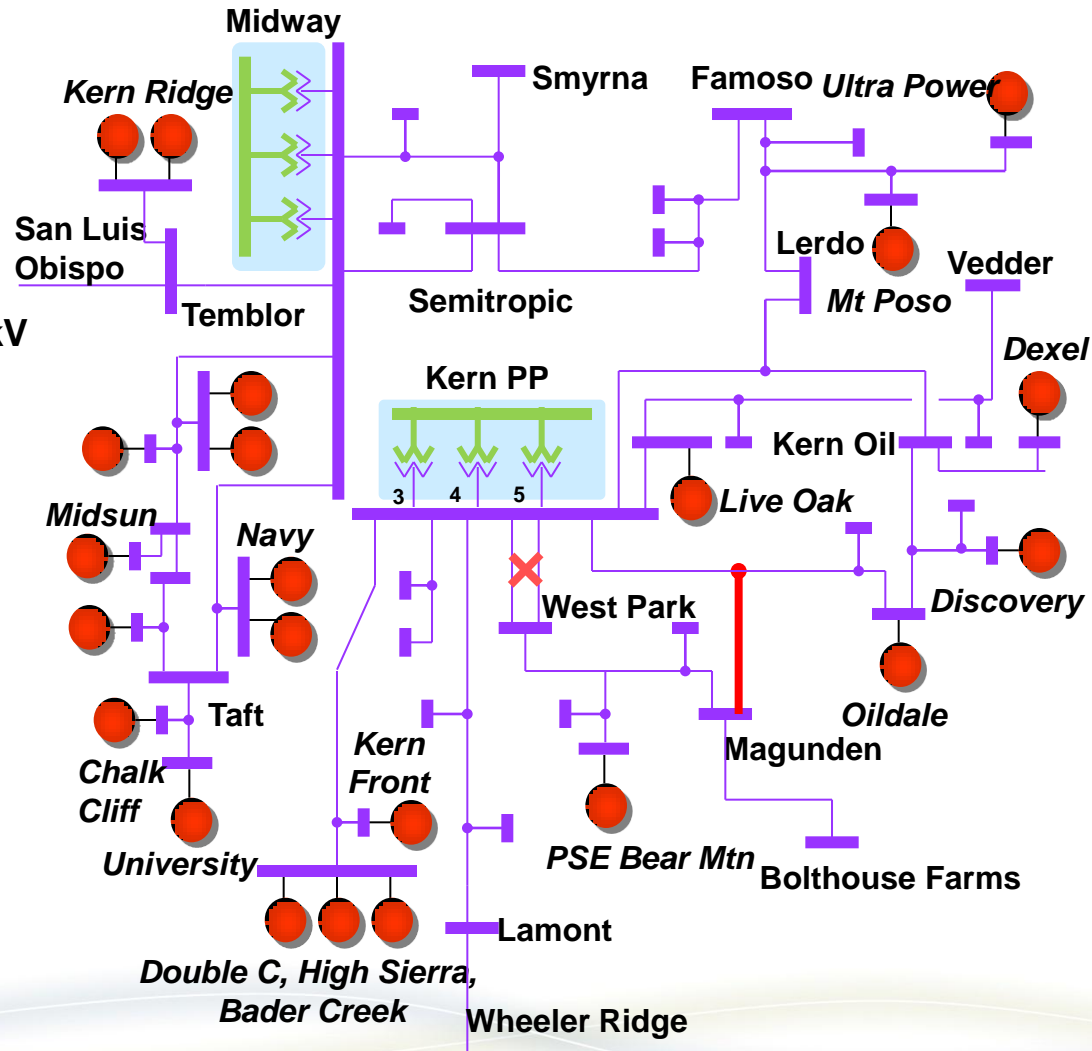

Kern Area LCR

Summary of 2018 LCR

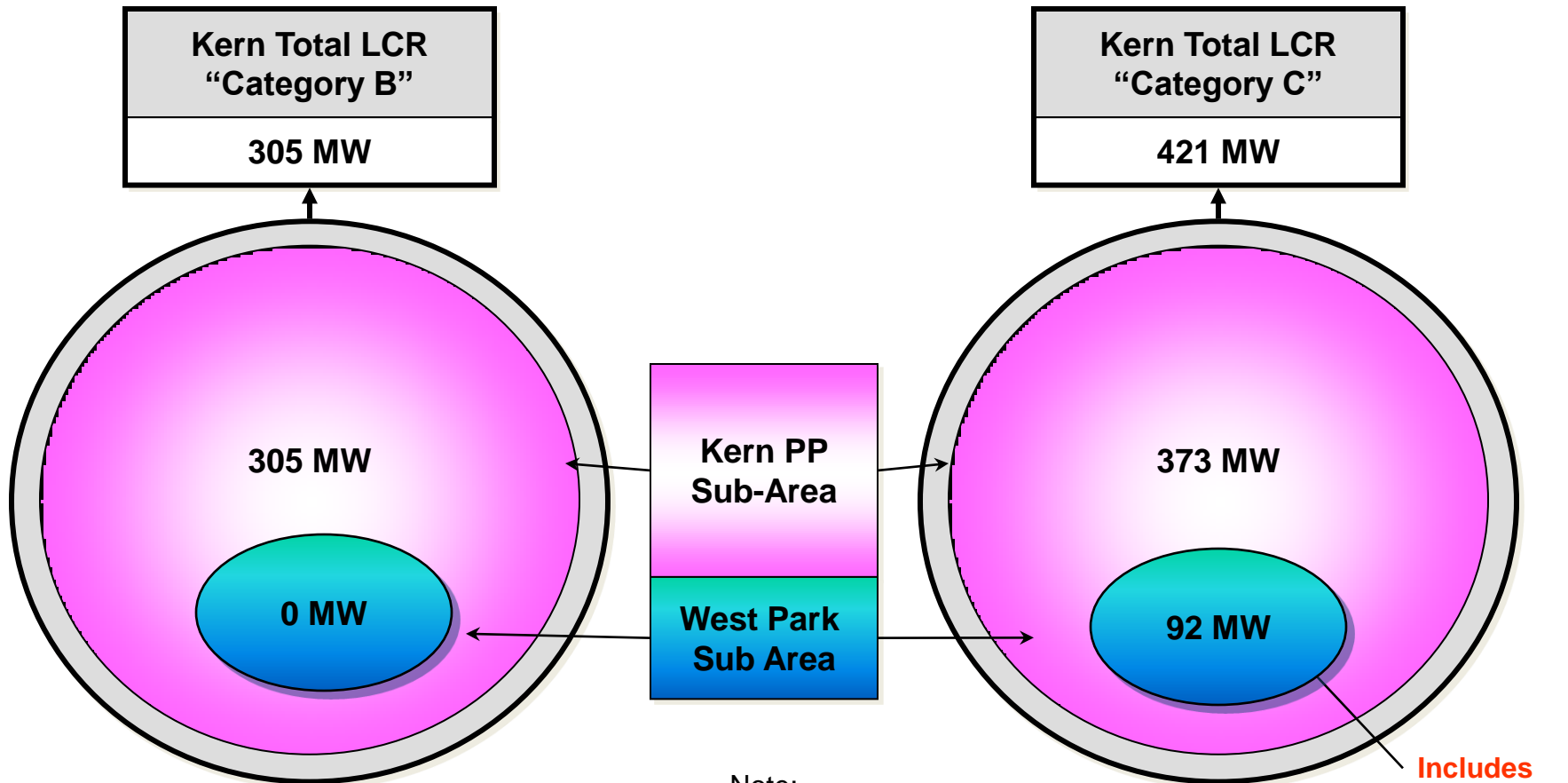

Note:
In the Kern area, due to overlapping of LCR sub-areas, the "Kern Total LCR" is *not* a simple sum, but rather an aggregated sum of LCR in individual sub-areas.

Changes

Since last year:

- 1) 2014 load forecast decreased by 30 MW vs. 2013
- 2) Error on Kern PP #4 230/115 model corrected
- 3) LCR has decreased by 164 MW
- 4) 2018 load forecast has increased by 17 MW vs. 2017
- 5) Long-term LCR has decreased by 13 MW

Your comments and questions are welcome.

For written comments, please send to: RegionalTransmission@caiso.com

Greater Fresno Area

Electrical Boundaries and LCR Sub-Areas

Electrical Boundaries:

- Gates – McCall 230 kV line
- Gates – Gregg 230 kV line
- Gates 230/70 kV transformer #1
- Panoche 230/115 kV transformer #1
- Panoche 230/115 kV transformer #2
- Panoche – Kearney 230 kV line
- Panoche – Helm 230 kV line
- Warnerville – Wilson 230 kV line
- Melones – Wilson 230 kV line
- Los Banos #3 230/70 kV transformer
- Los Banos #4 230/70 kV transformer
- San Miguel – Coalinga #1 70 kV line
- Smyrna – Alpaugh – Corcoran 115 kV line

LCR Sub-Areas:

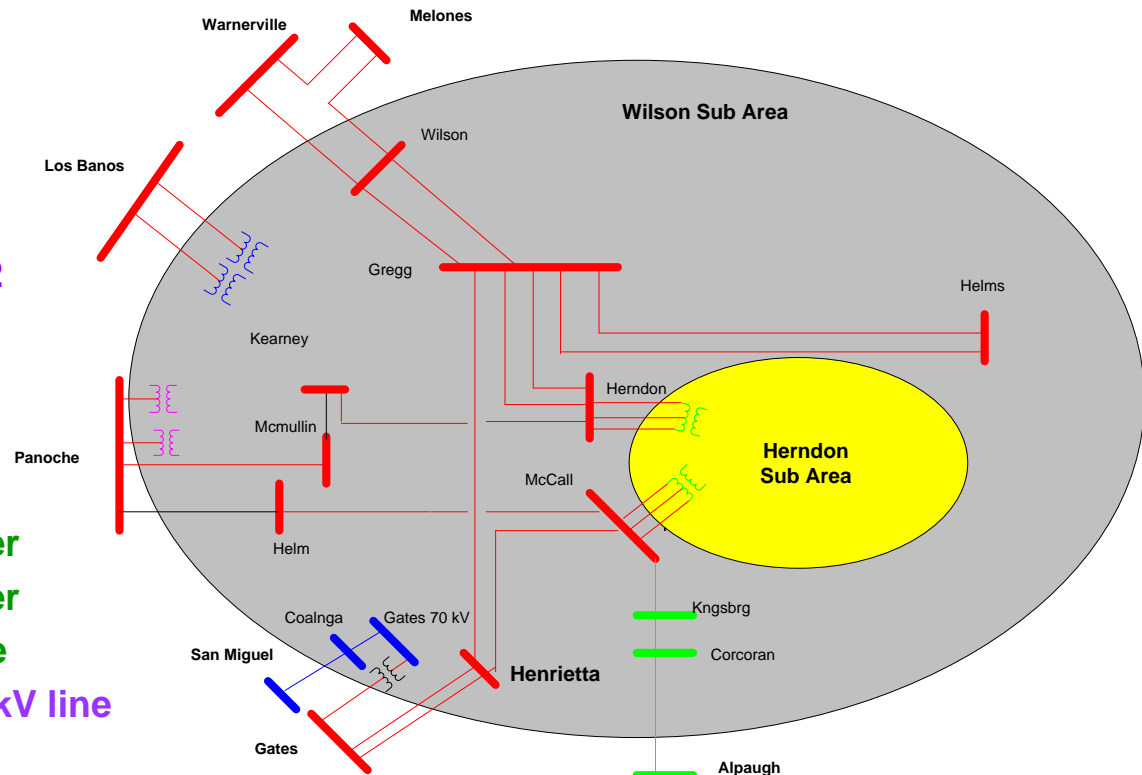

Fresno Area Overview

Area Generation, Load, Transmission and Path Flows

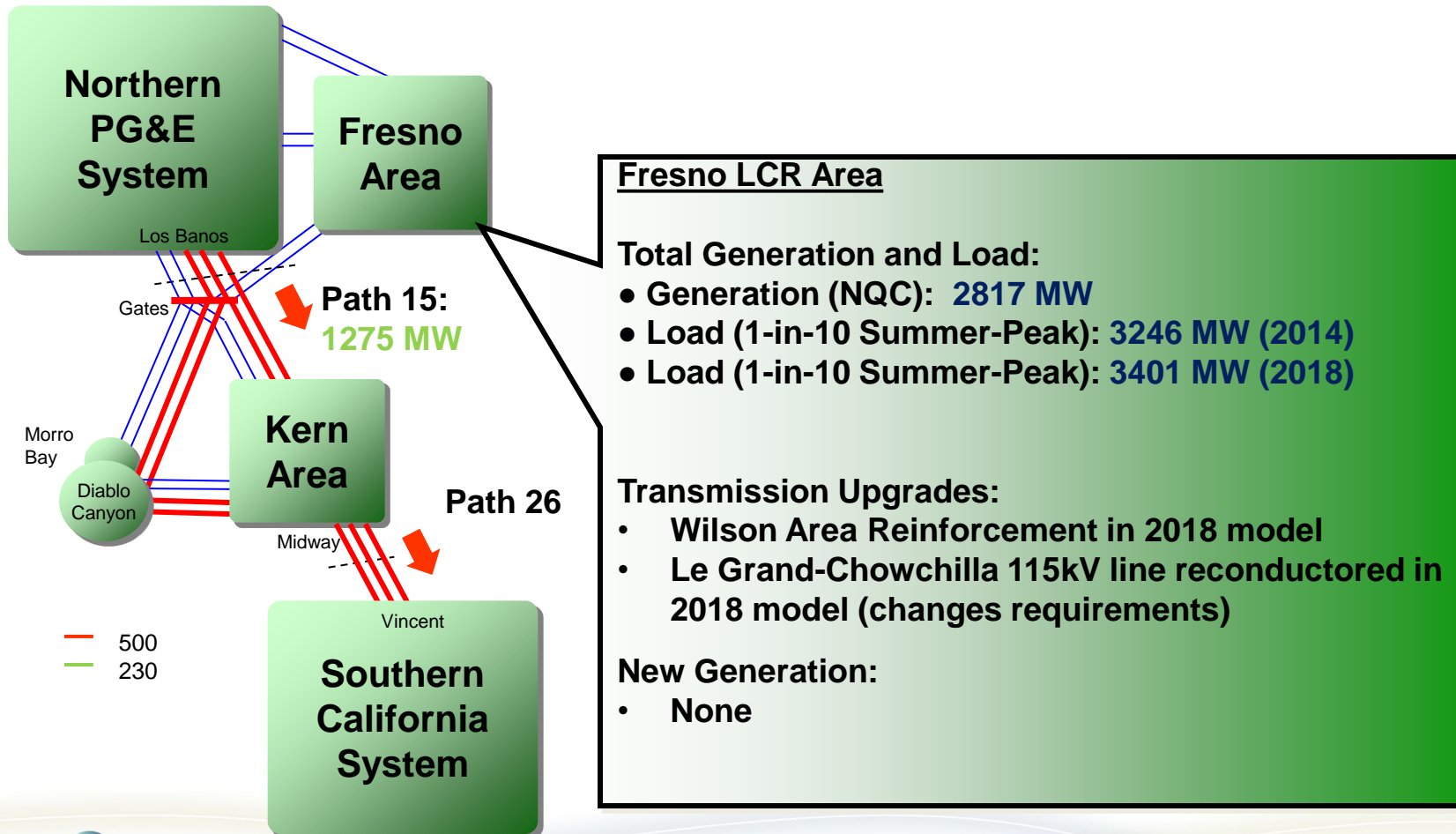

Fresno Area LCR

2014 Wilson Sub-Area

Limiting Contingencies:

Category C:

- L-1/G-1: Melones – Wilson 230 kV & Helms unit #3

Category B:

- L-1/G-1: Melones – Wilson 230 kV & Helms unit #3
- Constraint: Warnerville-Wilson 230kV

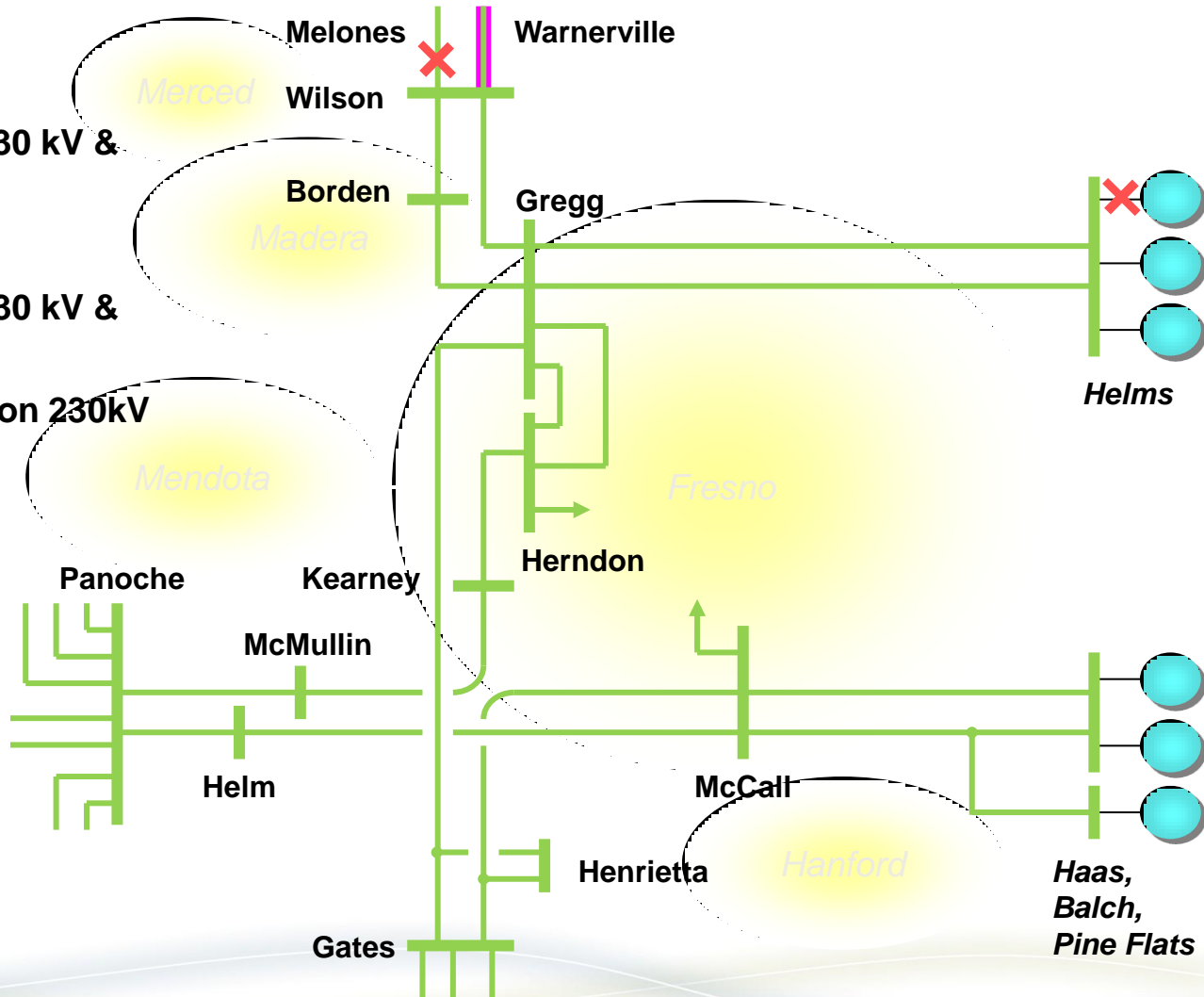

LCR Results (MW):

Contingency	Cat. B	Cat. C
LCR	1857	1857

Including:

QF	163	163
Muni	151	151
Deficiency	0	0

Fresno Area LCR

2014 Herndon Sub-Area

Limiting Contingency:

Category B:

- L-1/G-1: Herndon-Barton 115kV & Kerckhoff 2 PH
- Constraint: Herndon-Manchester 115kV

Category C:

- L-1-1: Herndon-Barton 115kV & Herndon-Woodward 115kV
- Constraint: Herndon-Manchester 115kV

LCR Results (MW):

Contingency	Cat. B	Cat. C
LCR	444	400

Including:

QF	42	42
Muni	83	83
Deficiency	0	0

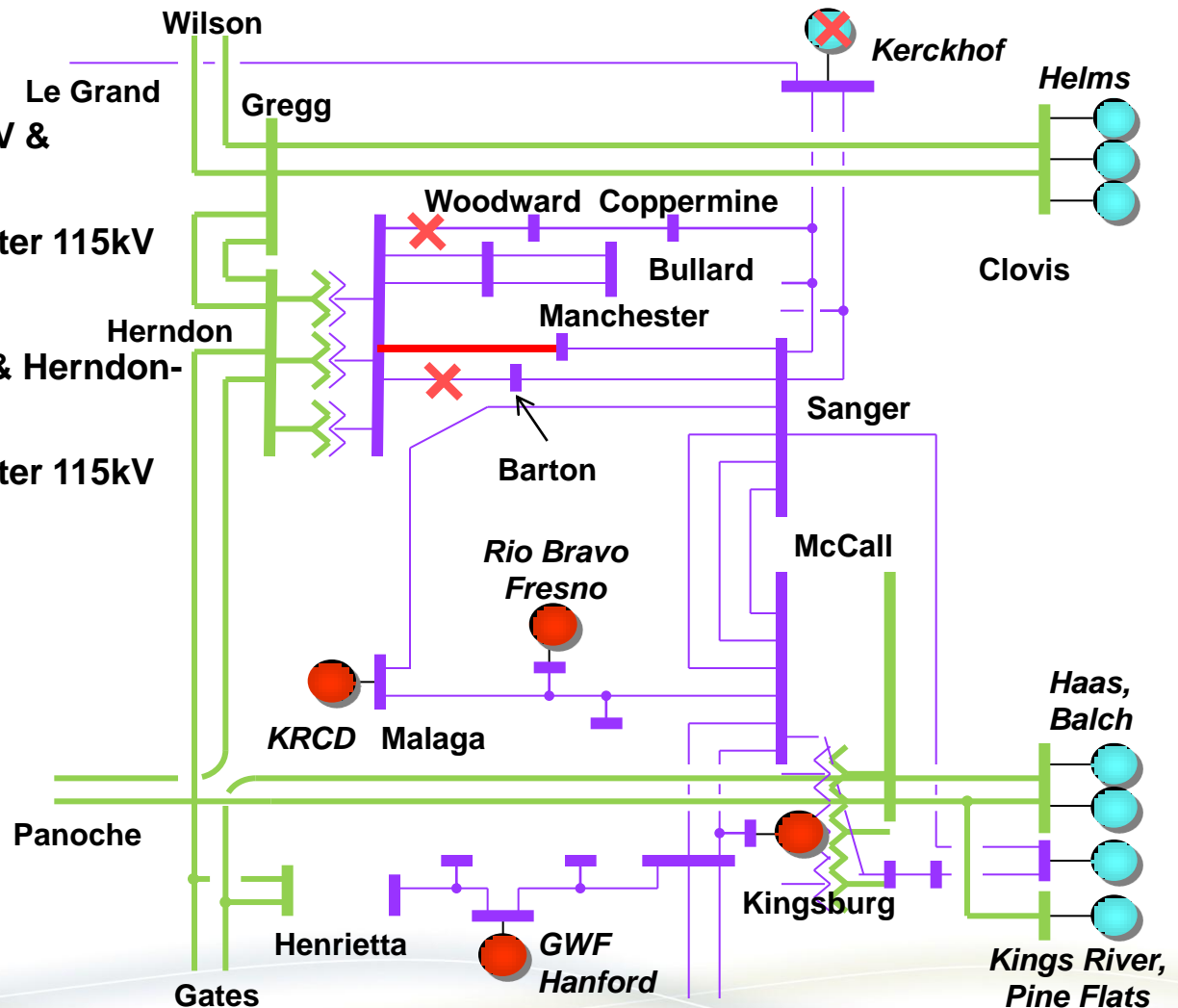

Fresno Area LCR

Summary of 2014 LCR

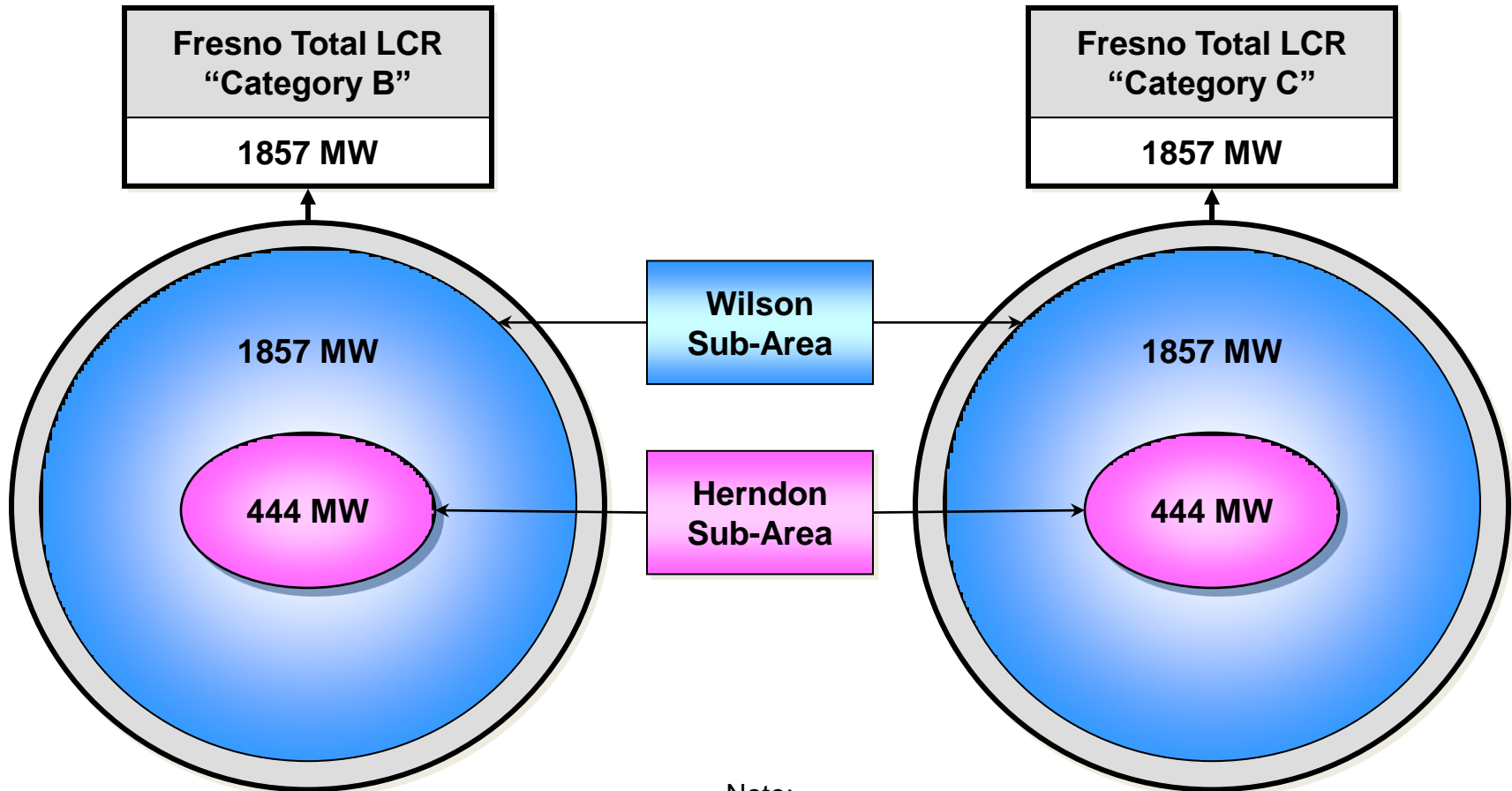

Note:

In the Fresno area, due to overlapping of LCR sub-areas, the "Fresno Total LCR" is *not* a simple sum, but rather an aggregated sum of LCR in individual sub-areas.

Fresno Area LCR

2018 Wilson Sub-Area

Limiting Contingencies:

Category C:

- L-1/G-1: Melones – Wilson 230 kV & Helms unit #3

Category B:

- L-1/G-1: Melones – Wilson 230 kV & Helms unit #3
- Constraint: Warnerville-Wilson 230kV

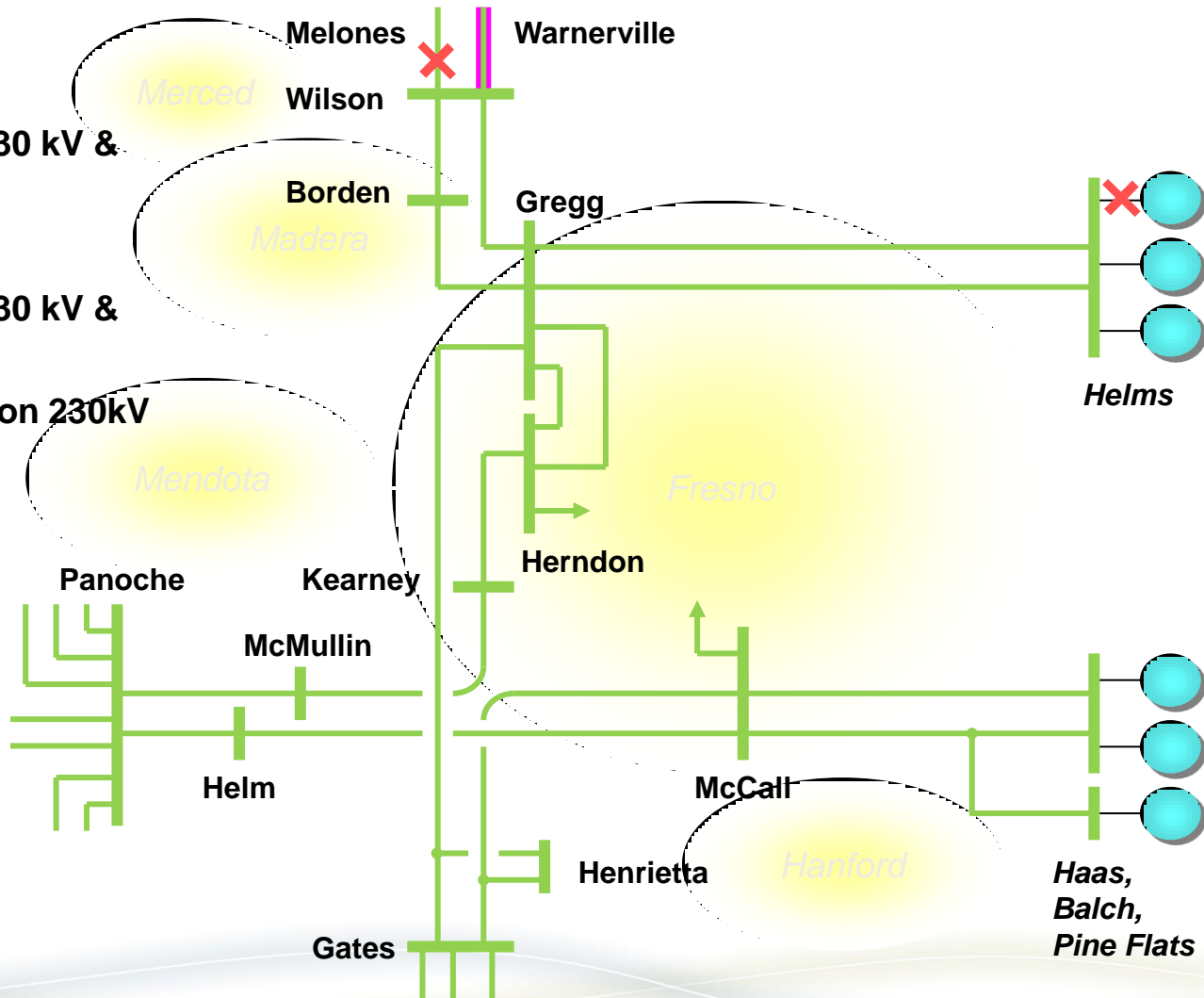

LCR Results (MW):

Contingency	Cat. B	Cat. C
LCR	2110	2110

Including:

QF	163	163
Muni	151	151
Deficiency	0	0

Fresno Area LCR

2018 Herndon Sub-Area

Limiting Contingency:

Category B:

- None. Reconductor of Le Grand-Chowchilla 115kV eliminates requirement

Category C:

- L-1-1: Herndon-Barton 115kV & Herndon-Woodward 115kV
- Constraint: Herndon-Manchester 115kV

LCR Results (MW):

Contingency	Cat. B	Cat. C
LCR	0	370

Including:

QF	42	42
Muni	83	83
Deficiency	0	0

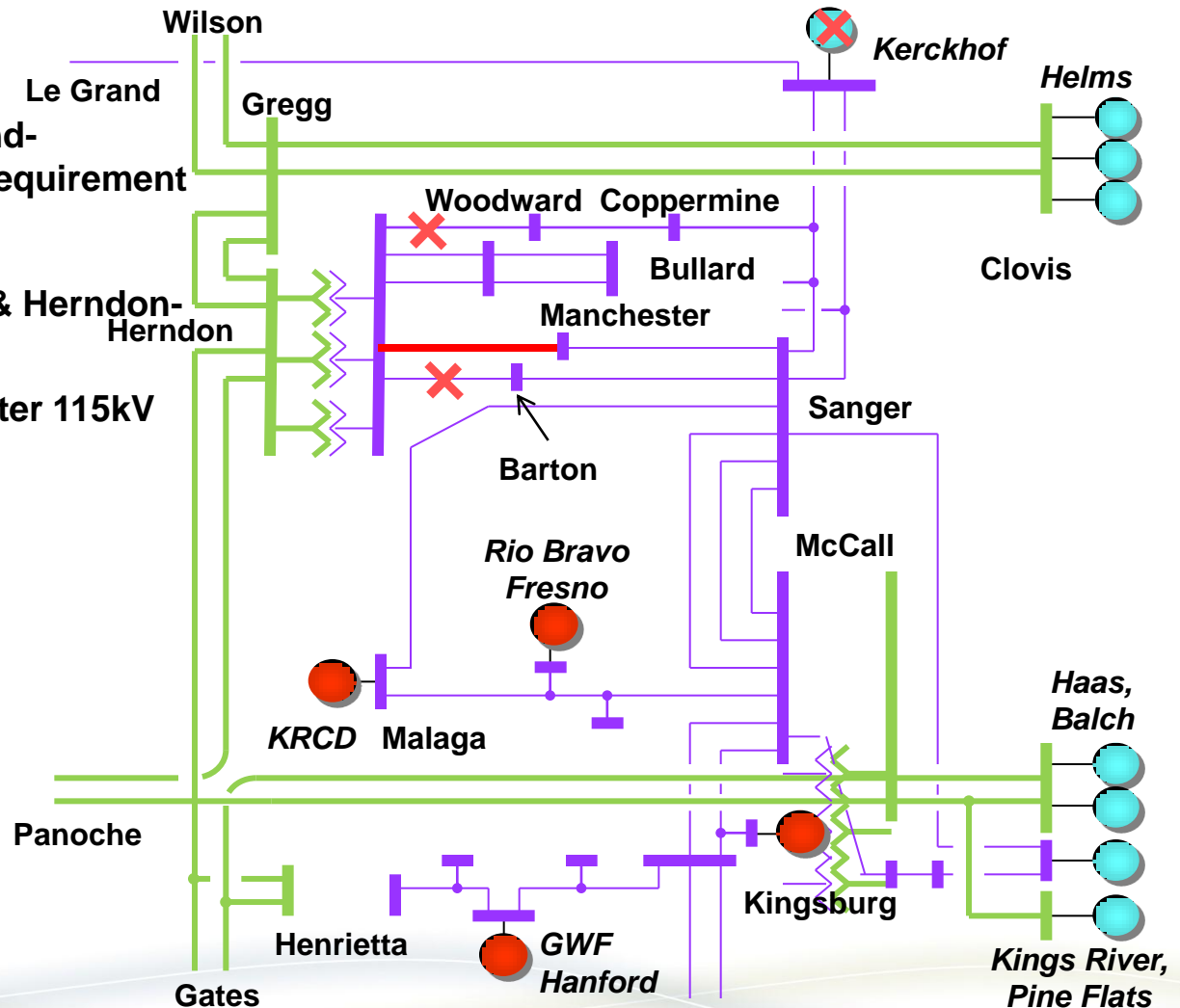

Fresno Area LCR

Summary of 2018 LCR

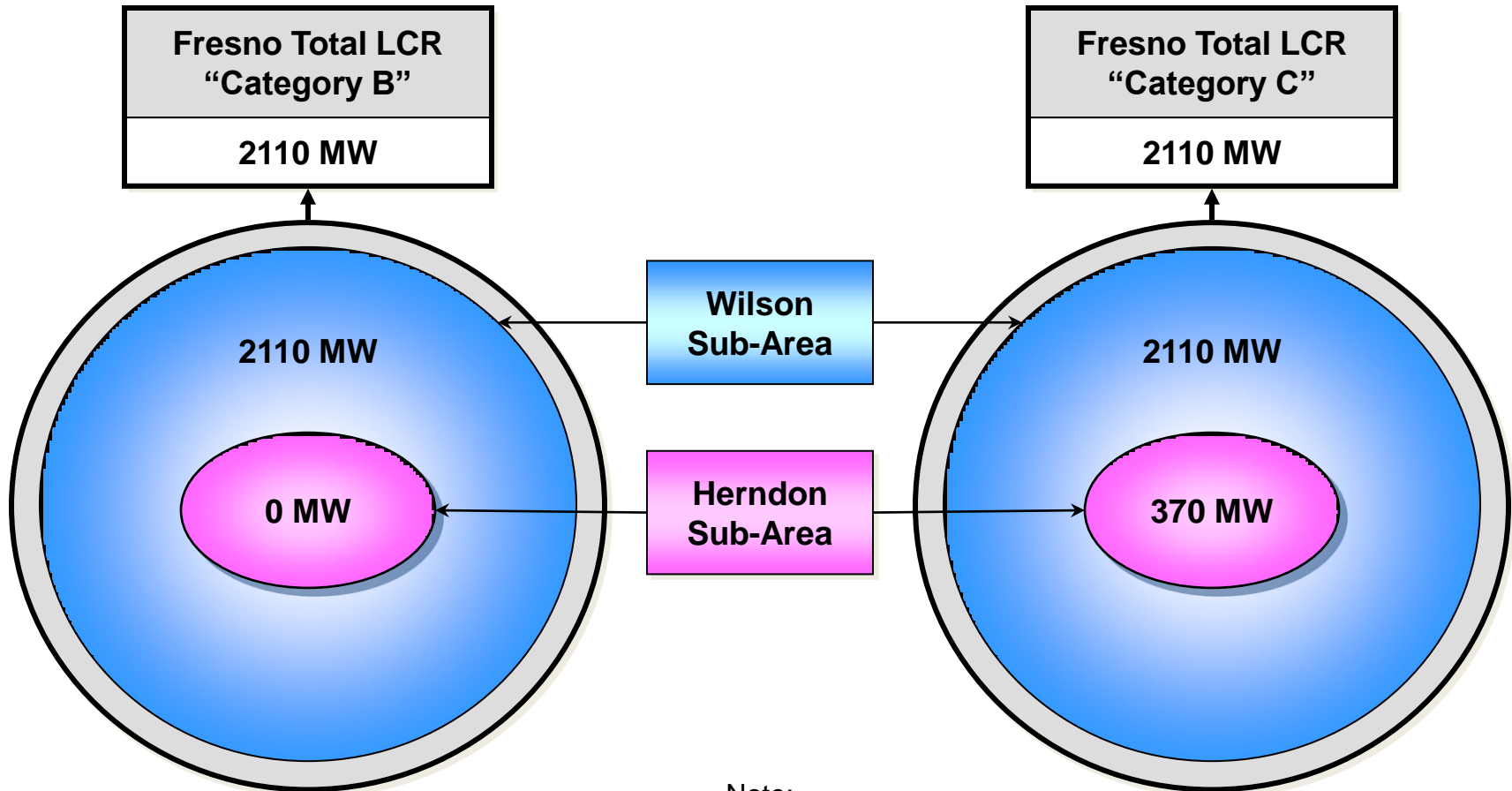

Note:

In the Fresno area, due to overlapping of LCR sub-areas, the "Fresno Total LCR" is *not* a simple sum, but rather an aggregated sum of LCR in individual sub-areas.

Changes

Since last year:

- 1) 2014 load forecast increased by 133 MW vs. 2013
- 2) LCR has increased by 71 MW
- 3) 2018 load forecast has increased by 37 MW vs. 2017
- 4) Long-term LCR has stayed the same
- 5) Le Grand-Chowchilla 115 kV reconductor affects generation, lowering Herndon Category C LCR and eliminates Category B LCR

Your comments and questions are welcome.

For written comments, please send to: RegionalTransmission@caiso.com