

2014 and 2018 Draft LCR Study Results - Sierra and Stockton

Binaya Shrestha
Senior Regional Transmission Engineer

Stakeholder Meeting

March 7, 2013

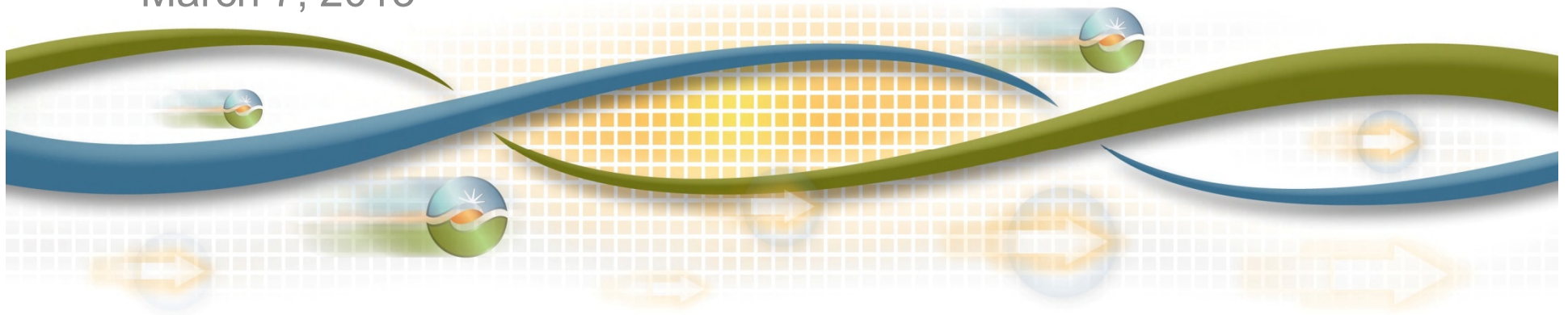

Sierra Area Load and Resources (MW)

		2014	2018
Load	=	1843	2069
Transmission Losses	=	115	107
Total Load	=	1958	2176
Market Generation	=	769	769
Muni Generation	=	1140	1140
QF Generation	=	226	226
Total Qualifying Capacity	=	2135	2135

Northern Sierra

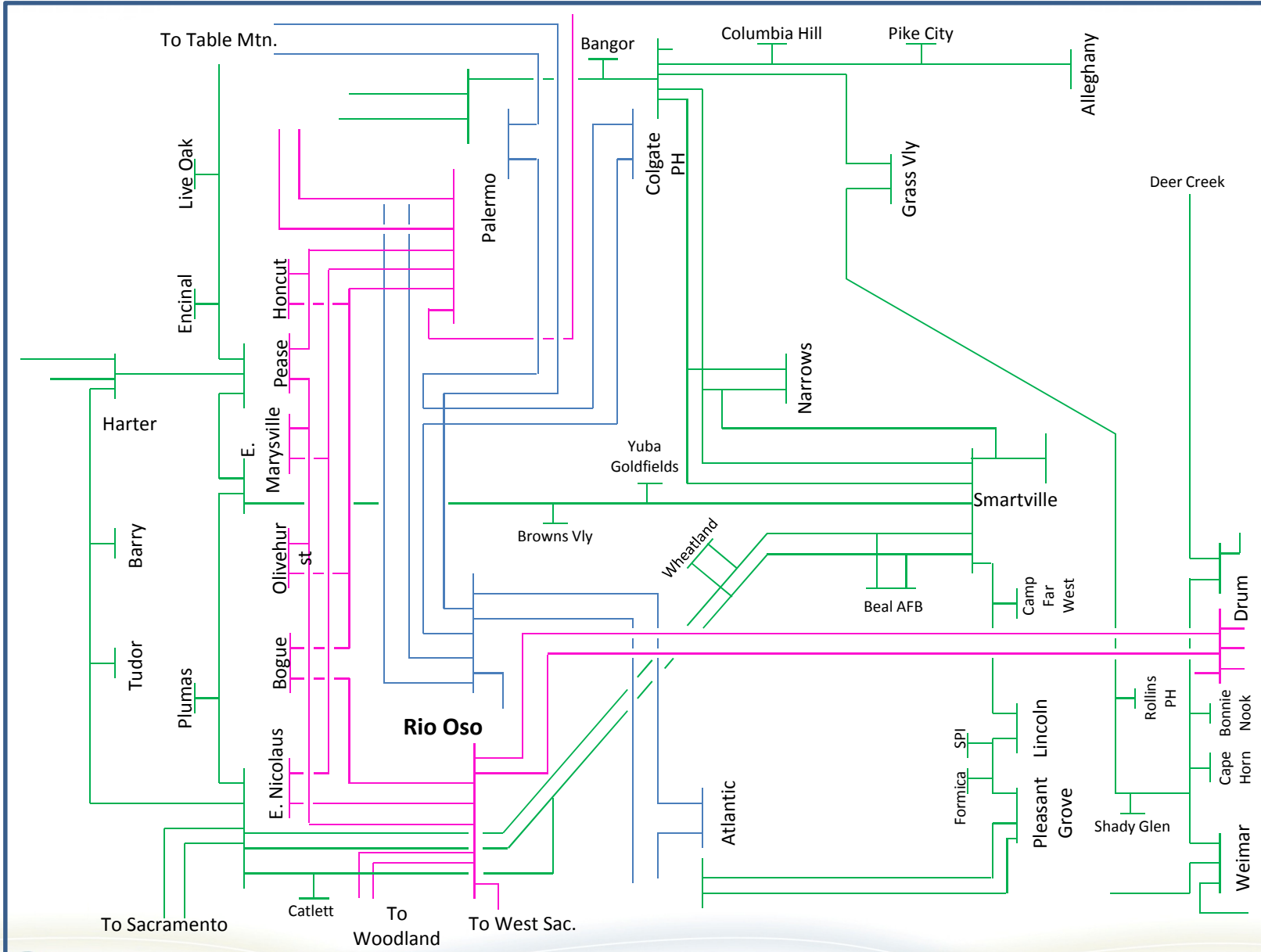

Southern Sierra

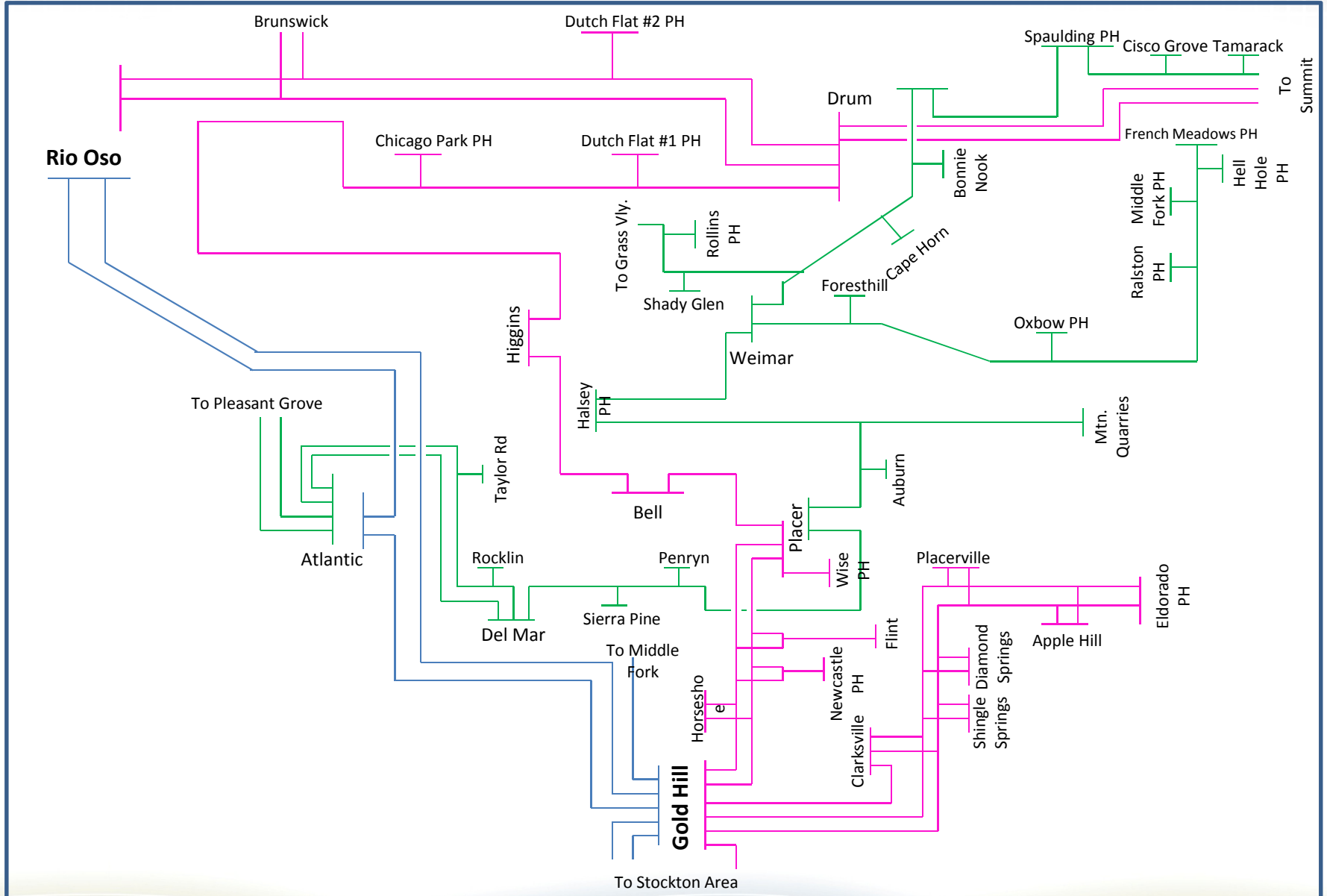



New transmission projects modeled:

1. Table Mountain-Rio Oso 230 kV Reconductoring and Tower Upgrade
2. Gold Hill – Horseshoe 115 kV line Reconductoring
3. Palermo-Rio Oso 115 kV Reconductoring
4. Gold Hill-Missouri Flat #1 and #2 115 kV line Reconductoring (2018 only)
5. Rio Oso #1 and #2 230/115 kV Transformer Replacement (2018 only)
6. Vaca Dixon-Davis Voltage Conversion (2018 only)
7. New Rio Oso-Atlantic 230 kV line (2018 only)
8. South of Palermo 115 kV Reinforcement (2018 only)

Critical Sierra Area Contingencies South of Table Mountain

South of Table Mountain Sub-area – Category C

2014 LCR need: 1803 MW (includes 171 MW of QF and 1103 MW of Muni generation)

2018 LCR need: 1114 MW (includes 171 MW of QF and 1103 MW of Muni generation)

Contingency: Table Mountain-Rio Oso 230 kV and Table Mountain-Palermo 230 kV DCTL outage

Limiting component: Thermal overload on the Caribou-Palermo 115 kV line

South of Table Mountain Sub-area – Category B

2014: No additional category B requirement. Units required for South of Palermo satisfy the category B requirement for this sub-area.

2018 LCR need: 864 MW (includes 171 MW of QF and 1103 MW of Muni generation)

Contingency: Table Mountain-Rio Oso 230 kV line with Belden unit out of service

Limiting component: Thermal overload on the Table Mountain-Palermo 230 kV line

Critical Sierra Area Contingencies South of Palermo

South of Palermo Sub-area – Category C

2014 LCR need: 1643 MW (includes 59 MW of QF and 639 MW of Muni generation as well as 256 MW of deficiency)

Contingency: Double Circuit Tower Line Table Mountain-Rio Oso and Colgate-Rio Oso 230 kV lines

Limiting component: Thermal overload on the Pease-Rio Oso 115 kV line

2018: No requirement due to South of Palermo 115 kV Reinforcement project.

South of Palermo Sub-area – Category B

2014 LCR need: 1275 MW (includes 59 MW of QF and 639 MW of Muni generation)

Contingency: Palermo-E. Nicolaus 115 kV line with Belden unit out of service

Limiting component: Thermal overload on the Pease-Rio Oso 115 kV line

2018: No requirement due to South of Palermo 115 kV Reinforcement project.

Critical Sierra Area Contingencies

Drum-Rio Oso

Drum-Rio Oso Sub-area – Category C

2014 LCR need: 698 MW (includes 171 MW of QF and 198 MW of Muni generation as well as 7 MW of deficiency)

Contingency: Rio Oso #2 230/115 kV transformer and Rio Oso-Brighton 230 kV line

Limiting component: Thermal overload on the Rio Oso #1 230/115 kV transformer

2018: No requirement due to Rio Oso Transformers Replacement project.

Drum-Rio Oso Sub-area – Category B

2014 LCR need: 247 MW (includes 171 MW of QF and 198 MW of Muni generation)

Contingency: Rio Oso # 2 230/115 kV transformer

Limiting component: Thermal overload on the Rio Oso #1 230/115 kV transformer

2018: No requirement due to Rio Oso Transformers Replacement project.

Critical Sierra Area Contingencies South of Rio Oso

South of Rio Oso Sub-area – Category C

2014 LCR need: 726 MW (includes 31 MW of QF and 593 MW of Muni generation as well as 16 MW of deficiency)

Contingency: Rio Oso-Gold Hill 230 kV and Rio Oso-Lincoln 115 kV lines

Limiting component: Thermal overload on the Rio Oso-Atlantic 230 kV line

2018: No requirement due to New Atlantic-Rio Oso 230 kV line project.

South of Rio Oso Sub-area – Category B

2014 LCR need: 635 MW (includes 31 MW of QF and 593 MW of Muni generation)

Contingency: Rio Oso-Gold Hill 230 kV line and Ralston unit

Limiting component: Thermal overload on the Rio Oso-Atlantic 230 kV line

2018: No requirement due to New Atlantic-Rio Oso 230 kV line project.

Critical Sierra Area Contingencies

Pease

Pease Sub-area – Category C

2014: Same as category B.

2018 LCR need: 103 MW (includes 59 MW of QF generation)

Contingency: Pease 115/60 kV transformer and YCEC unit

Limiting component: Thermal overload on the Table Mountain-Pease 60 kV line

Pease Sub-area – Category B

2014 LCR need: 122 MW (includes 59 MW of QF generation)

Contingency: Palermo-East Nicolaus 115 kV line with YCEC unit out of service

Limiting component: Thermal overload on the Palermo-Pease 115 kV line

2018 LCR need: 67 MW (includes 59 MW of QF generation)

Contingency: Pease 115/60 kV transformer

Limiting component: Thermal overload on the Table Mountain-Pease 60 kV line

Critical Sierra Area Contingencies

Placer

Placer Sub-area – Category C

2014 LCR need: 107 MW (includes 38 MW of QF and Muni generation as well as 26 MW of deficiency)

2018 LCR need: 120 MW (includes 38 MW of QF and Muni generation as well as 39 MW of deficiency)

Contingency: Gold Hill-Placer #1 and #2 115 kV lines

Limiting component: Thermal overload on the Drum-Higgins 115 kV line

Placer Sub-area – Category B

2014 LCR need: 87 MW (includes 38 MW of QF and Muni generation)

2018 LCR need: 114 MW (includes 38 MW of QF and Muni generation as well as 26 MW of deficiency)

Contingency: Gold Hill-Placer #2 115 kV line with Chicago Park unit out of service

Limiting component: Thermal overload on the Drum-Higgins 115 kV line

Critical Sierra Area Contingencies Placerville

Placerville Sub-area – Category C

2014 LCR need: 6 MW (includes 0 MW of QF and Muni generation)

2018 LCR need: 20 MW (includes 0 MW of QF and Muni generation)

Contingency: Gold Hill-Clarksville and Gold Hill-Missouri Flat #2 115 kV lines

Limiting component: Thermal overload on the Gold Hill-Missouri Flat #1 115 kV line

Placerville Sub-area – Category B

2014 LCR need: No requirement

2018 LCR need: No requirement

Critical Sierra Area Contingencies Aggregate

	QF (MW)	Muni (MW)	Market (MW)	Max. Qualifying Capacity (MW)
Available generation	226	1140	769	2135

	Existing Generation Capacity Needed (MW)		Deficiency (MW)		Total MW Need	
	2014	2018	2014	2018	2014	2018
Category B (Single)	1414	864	0	26	1414	890
Category C (Multiple)	1803	1114	268	39	2071	1153

Each unit is only counted once, regardless in how many sub-areas it is needed.

In order to come up with an aggregate deficiency, where applicable the deficiencies in each smaller sub-area has been accounted for (based on their effectiveness factors) toward the deficiency of a much larger sub-area.

Changes

2014 LCR compared to 2013:

- Load forecast went up by 212 MW.
- Overall LCR need has increased by 141 MW.

2018 LCR compared to 2017:

- Load forecast went up by 32 MW.
- Overall LCR need has decreased by 816 MW due to South of Palermo 115 kV reinforcement project.

Your comments and questions are welcome.

For written comments, please send to: RegionalTransmission@caiso.com

Stockton Area Load and Resources (MW)

		2014	2018
Load	=	1141	1203
Transmission Losses	=	22	21
Total Load	=	1163	1224
Market Generation	=	120	222
Muni Generation	=	142	142
QF Generation	=	414	414
Total Qualifying Capacity	=	676	778



New transmission projects modeled:

1. Weber-Stockton A #1 & #2 60 kV lines Reconductor
2. Weber 230/60 kV Transformer Replacement (2018 only)
3. Vierra 115 kV loop-in (2018 only)

Critical Stockton Area Contingencies

Tesla-Bellota Sub-area

Tesla-Bellota Sub-area – Category C

TOTAL 2014 LCR need: 597 MW (70 MW of QF and 119 MW of Muni and 178 MW of deficiency)

Contingency 1: Schulte-Lammers and Schulte-Kasson-Manteca 115 kV lines.

Limiting component 1: Thermal overload on the Tesla-Tracy 115 kV line.

LCR Need: 476 MW (70 MW of QF and 119 MW of Muni and 178 MW of deficiency).

Contingency 2: Tesla-Tracy 115 kV line and Tesla-Schulte #2 115 kV line.

Limiting component 2: Thermal overload on the Tesla-Schulte #1 115 kV line.

LCR Need: 419 MW (includes 70 MW of QF and 119 MW of Muni generation).

2018 LCR need: 347 MW (70 MW of QF and 119 MW of Muni generation)

Contingency: Tesla-Vierra and Tesla-Schulte #2 115 kV lines.

Limiting component: Thermal overload on the Tesla-Schulte #1 115 kV line.

Tesla-Bellota 115 kV Area Transmission

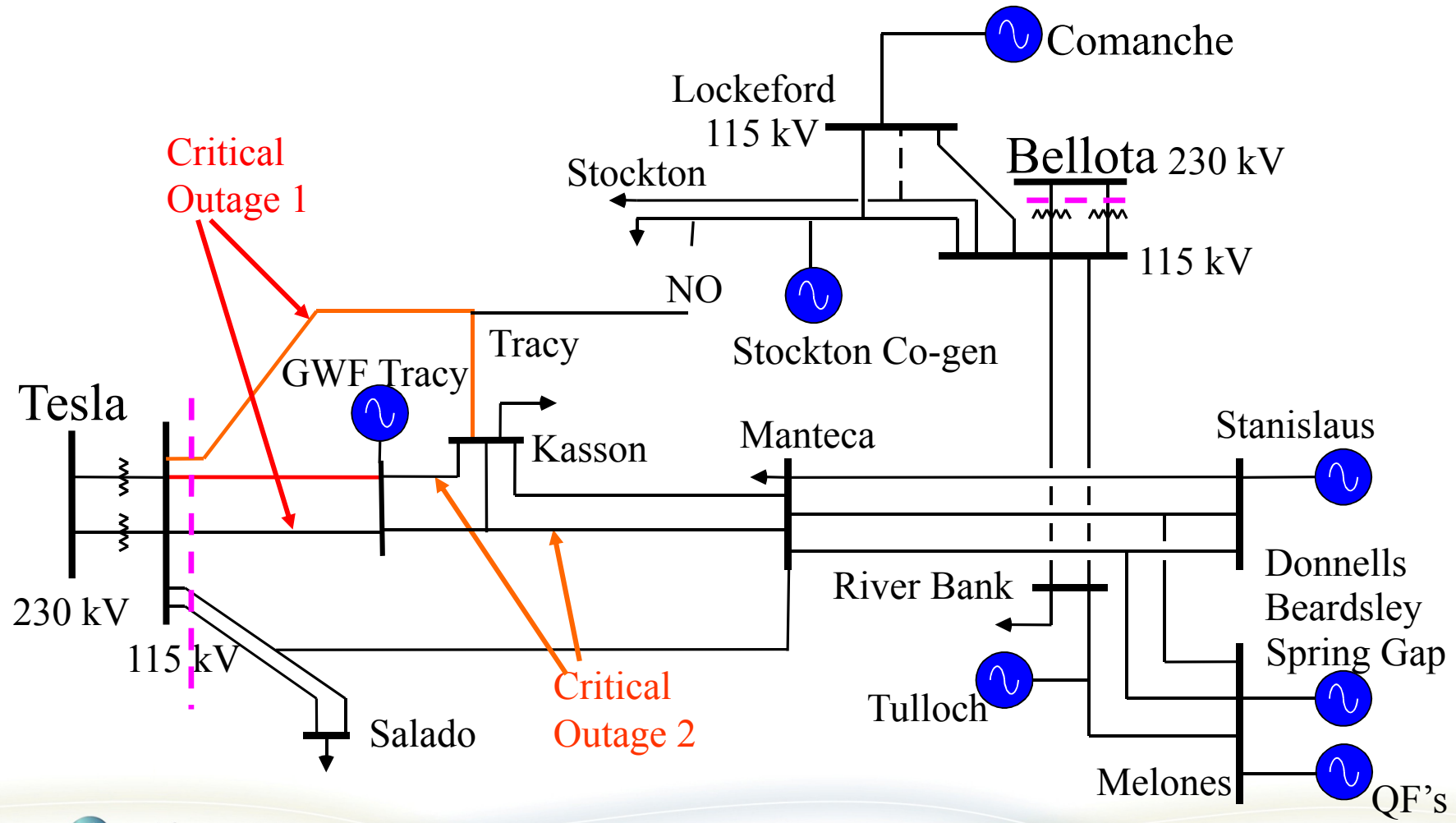

Critical Stockton Area Contingencies

Tesla-Bellota Sub-area

Tesla-Bellota Sub-area – Category B

2014 LCR Need: 352 MW (includes 70 MW of QF and 119 MW of Muni generation).

Contingency: Tesla-Tracy 115 kV line and the loss of GWF Tracy #3.

Limiting component: Thermal overload on the Tesla-Schulte #1 115 kV line.

2018 LCR Need: 284 MW (includes 70 MW of QF and 119 MW of Muni generation).

Contingency: Tesla-Schulte #2 115 kV line and the loss of GWF Tracy #3.

Limiting component: Thermal overload on the Tesla-Schulte #1 115 kV line.

Critical Stockton Area Contingencies Stanislaus Sub-area

Stanislaus Sub-area – Category C

2014 LCR need: Same as Category B.

2018 LCR need: Same as Category B.

Stanislaus Sub-area – Category B

2014 LCR need: 127 MW (includes 19 MW of QF and 92 MW of Muni generation)

2018 LCR need: 134 MW (includes 19 MW of QF and 92 MW of Muni generation)

Contingency: Bellota-Riverbank-Melones 115 kV line and Stanislaus PH

Limiting component: Thermal overload on the River Bank Jct.-Manteca 115 kV line

Critical Stockton Area Contingencies

Lockeford Sub-area

Lockeford Sub-area – Category C

2014 LCR need: 55 MW (includes 2 MW of QF and 23 MW of Muni generation as well as 29 MW of deficiency)

2018 LCR need: 61 MW (includes 2 MW of QF and 23 MW of Muni generation as well as 35 MW of deficiency)

Contingency: Lockeford-Industrial and Lockeford-Lodi #2 60 kV lines

Limiting component: Thermal overload on the Lockeford-Lodi Jct. section of the Lockeford-Lodi #3 60 kV line

Lockeford Sub-area – Category B

2014 LCR need: No requirement.

2018 LCR need: No requirement.

Critical Stockton Area Contingencies

Weber Sub-area

Weber Sub-area – Category C

2014 LCR need: 62 MW (includes 37 MW of QF generation as well as 25 MW of deficiency)

Contingency: Weber 230/60 kV Transformer #1 and Cogeneration National Unit

Limiting component: Weber 230/60 kV Transformer #2 & 2A

2018 LCR need: 10 MW (includes 37 MW of QF generation)

Contingency: Stockton A-Weber #1 and #2 60 kV lines

Limiting component: Thermal overload on the Stockton A-Weber #3 60 kV line

Weber Sub-area – Category B

2014 LCR need: 27 MW (includes 37 MW of QF generation)

Contingency: Weber 230/60 kV Transformer #1

Limiting component: Weber 230/60 kV Transformer #2 & 2A

2018 LCR need: No requirement due to Weber 230/60 kV transformer replacement project.

Critical Stockton Area Contingencies Aggregate

Available generation	QF (MW)	Muni (MW)	Market (MW)	Max. Qualifying Capacity (MW)
2014	414	142	120	676
2018	414	142	222	778

	Existing Generation Capacity Needed (MW)		Deficiency (MW)		Total MW Need	
	2014	2018	2014	2018	2014	2018
Category B (Single)	470	284	0	0	470	284
Category C (Multiple)	481	382	232	35	713	417

Each unit is only counted once, regardless in how many sub-areas it is needed.

In order to come up with an aggregate deficiency, where applicable the deficiencies in each smaller sub-area has been accounted for (based on their effectiveness factors) toward the deficiency of a much larger sub-area.

Changes

2014 LCR compared to 2013:

- Load forecast went up by 54 MW.
- Weber 230/60 kV Transformer replacement project delayed.
- Overall LCR need has increased by 146 MW.

2018 LCR compared to 2017:

- Load forecast went up by 10 MW.
- Overall LCR need has decreased by 23 MW.

Your comments and questions are welcome.

For written comments, please send to: RegionalTransmission@caiso.com