

ALSTON & BIRD LLP

The Atlantic Building
950 F Street, NW
Washington, DC 20004-1404

202-239-3300
Fax: 202-239-3333

Michael Kunselman

Direct Dial: 202-239-3395

E-mail: michael.kunselman@alston.com

December 14, 2010

The Honorable Kimberly D. Bose
Secretary
Federal Energy Regulatory Commission
888 First Street, NE
Washington, DC 20426

**Re: California Independent System Operator Corporation
Docket No. ER11-____-000**

**ISO Service Agreement No.1748, Non-Conforming Large
Generator Interconnection Agreement**

Dear Secretary Bose:

The California Independent System Operator Corporation (“ISO”) submits for Commission filing and acceptance the unexecuted Large Generator Interconnection Agreement between the ISO, Southern California Edison Company (“SCE”), and Granite Wind, LLC. (“Granite Wind”) for the Granite Mountain Project.¹ On November 23, 2010, SCE submitted a compliance filing of this same LGIA in Docket No. ER11-2177-000 as non-conforming to the pro forma LGIA set forth in the ISO tariff. The ISO is submitting its own filing of this LGIA in order to have it accepted as a non-conforming service agreement of the ISO and to enter it into the ISO’s eTariff system consistent with SCE’s filing. The ISO requests that the Commission’s consideration of this filing be consolidated with the Commission’s review of SCE’s filing of this same agreement, designated by SCE as its Service Agreement No. 91 under its Transmission Owner Tariff in Docket No. ER11-2177.

I. Variation from the *Pro Forma* LGIA

As described in SCE’s filing in Docket No. ER11-2177, the Mojave Solar Project is a 60 MW wind turbine generating facility that will be interconnecting to

¹ This filing is submitted pursuant to Section 205 of the Federal Power Act, 16 U.S.C. § 824d and Part 35 of the Commission’s regulations, 18 C.F.R. Part 35, and in compliance with Order No. 714, *Electronic Tariff Filings*, FERC Stats. & Regs. ¶ 31,276 (2009). The ISO is also sometimes referred to as the CAISO.

a new SCE-owned Jasper 220kV substation via a customer-owned 220 kV generation tie-line. SCE states that it has committed to up-front finance certain of the reliability network upgrades and distribution upgrades² necessary to interconnect the Granite Mountain Project contingent on SCE's receipt of Commission approval to recover the costs of abandoned plant from transmission ratepayers and Granite Mountain's achievement of specified development milestones.

As described in SCE's filing in Docket No. ER11-2177, the LGIA provides for these contingencies through provisions included in the appendices to the LGIA that may be interpreted as differing from the ISO's pro forma LGIA as they relate to SCE's commitment to finance these upgrade. These terms and conditions, agreed to by the parties to the LGIA, are as follows: (i) the definition of Abandoned Plant Approval in Section 8(a) of Appendix A; (ii) SCE's commitment to up-front finance the cost of certain reliability network upgrades and distribution upgrades as set forth in Appendix A of the LGIA; (iii) inclusion of development milestones, including actions to be taken following completion of or failure to complete milestones in Sections 13(d), (e), (g), (h) and (k) of Appendix A of the LGIA; (iv) limits on SCE's commitment to finance the network upgrades required for the Granite Mountain Project in Section 13 (f) of Appendix A; and (v) SCE's commitment to file for Abandoned Plant Approval within sixty (60) calendar days of the execution and filing of the LGIA in Section 13(j) of Appendix A.³ These non-conforming provisions are substantially similar to those that the Commission accepted in connection with earlier filings of nonconforming LGIAs made by SCE in Docket Nos. ER10-732 and ER10-2169.

The ISO is filing the Granite Wind LGIA as non-conforming ISO Service Agreement No. 1748 in order to have it accepted as a non-conforming service agreement of the ISO and to ensure that its eTariff records of non-conforming service agreements to which both it and SCE are parties are consistent with those of SCE. The ISO requests that the Commission's review of the instant filing be consolidated with its review of SCE's filing of this same LGIA in Docket No. ER11-2177.

² The reliability network upgrades that SCE has agreed to up-front finance are specified in Section 2(b)(i) of Appendix A to the LGIA and the distribution upgrades that it has agreed to up-front finance are specified in Section 3 of the LGIA.

³ In this regard, on December 9, 2010 SCE filed in Docket No. EL11-10 a Petition for Declaratory Order seeking incentives, including assurance from the Commission that SCE may recover 100 percent of its prudently incurred costs for the network and distribution upgrades that it has agreed to up-front fund in the Granite Wind LGIA if these facilities are abandoned due to circumstances outside SCE's control.

II. Effective Date

In its filing of the Granite Wind LGIA in Docket No. ER11-2177, SCE requested an effective date of November 24, 2010 for this LGIA. The ISO requests that the Commission specify that same effective date for the ISO's filing of this same LGIA in the instant proceeding.

To accommodate the foregoing requested effective date, the ISO respectfully requests waiver, pursuant to Section 35.11 of the Commission's regulations (18 C.F.R. § 35.11), of the 60-day notice requirement contained in Section 35.3 of the Commission's regulations (18 C.F.R. § 35.3), in order to permit the LGIA to become effective as of the requested effective date. As described in SCE's filing of this LGIA in Docket No. ER11-2177, good cause exists in that such waiver will enable SCE to commence permitting, engineering, design, and procurement of the facilities necessary to interconnect the Granite Mountain generating facility to the ISO controlled grid by Granite Wind's requested in-service date, thus facilitating the availability of power to customers in southern California. Granting the waiver will be consistent with prior Commission orders and the implementation by all parties to the LGIA pursuant to those orders. No harm will result to any entity from the specified effective date for the LGIA. Granting the requested waiver, therefore, is appropriate.

III. Expenses

No expense or cost associated with this filing has been alleged or judged in any judicial or administrative proceeding to be illegal, duplicative, unnecessary, or demonstratively the product of discriminatory employment practices.

IV. Service

Copies of this filing have been served upon Granite Wind, SCE, the California Public Utilities Commission, and the California Energy Commission and the parties to Docket No. ER11-2177. In addition, the filing has been served upon all ISO scheduling coordinators and on the ISO website.

The following are enclosed for filing:

- (1) this transmittal letter; and
- (2) a copy of the executed version of the non-conforming LGIA for Granite Wind, designated as Service Agreement No.1748.

V. Correspondence

The ISO requests that all correspondence, pleadings, and other communications concerning this filing be served upon the following:

Nancy Saracino
General Counsel
Sidney M. Davies
Assistant General Counsel
Baldassaro "Bill" Di Capo*
Senior Counsel
**California Independent System
Operator Corporation**
151 Blue Ravine Road
Folsom, CA 95630
Tel: (916) 351-4400
Fax: (916) 608-7296

E-mail:

nsaracino@caiso.com
sdavies@caiso.com
bdicapo@caiso.com

Michael Kunselman*

Alston & Bird LLP
The Atlantic Building
950 F Street, NW
Washington, DC 20004
Tel: (202) 756-3300
Fax: (202) 756-3333

E-mail:

michael.kunselman@alston.com

* Individuals designated for service pursuant to Rule 203(b)(3),
18 C.F.R. § 385.203(b)(3)

VI. Conclusion

The ISO respectfully requests that the Commission accept this filing and permit the LGIA for Granite Wind to be effective as of the date requested. If there are any questions concerning this filing, please contact the undersigned.

Respectfully submitted,

/s/ Michael Kunselman
Michael Kunselman

Nancy Saracino
General Counsel
Sidney M. Davies
Assistant General Counsel
Baldassaro "Bill" Di Capo
Senior Counsel

**California Independent System
Operator Corporation**
151 Blue Ravine Road
Folsom, CA 95630

Alston & Bird LLP
The Atlantic Building
950 F Street, NW
Washington, DC 20004

Counsel for the California Independent System Operator Corporation

California Independent System Operator Corporation
Non-Conforming Service Agreements
Tariff Record Title: Service Agreement No. 1748

**STANDARD LARGE GENERATOR INTERCONNECTION AGREEMENT (LGIA)
AMONG**

**GRANITE WIND, LLC
AND**

**SOUTHERN CALIFORNIA EDISON COMPANY
AND**

CALIFORNIA INDEPENDENT SYSTEM OPERATOR CORPORATION

TABLE OF CONTENTS

ARTICLE 1. DEFINITIONS	9
ARTICLE 2. EFFECTIVE DATE, TERM AND TERMINATION	17
2.1 Effective Date	17
2.2 Term of Agreement	17
2.3 Termination Procedures.....	17
2.3.1 Written Notice.....	17
2.3.2 Default.....	17
2.3.3 Suspension of Work	17
2.3.4.....	17
2.4 Termination Costs.....	17
2.4.1.....	18
2.4.2.....	18
2.4.3.....	18
2.5 Disconnection	18
2.6 Survival	18
ARTICLE 3. REGULATORY FILINGS AND CAISO TARIFF COMPLIANCE	19
3.1 Filing	19
3.2 Agreement Subject to CAISO Tariff	19
3.3 Relationship Between this LGIA and the CAISO Tariff	19
3.4 Relationship Between this LGIA and the QF PGA	19
ARTICLE 4. SCOPE OF SERVICE	19
4.1 Interconnection Service	19
4.2 Provision of Service	20
4.3 Performance Standards	20
4.4 No Transmission Service	20
4.5 Interconnection Customer Provided Services	20
ARTICLE 5. INTERCONNECTION FACILITIES ENGINEERING, PROCUREMENT, AND CONSTRUCTION	20
5.1 Options	20
5.1.1 Standard Option	21
5.1.2 Alternate Option	21
5.1.3 Option to Build.....	21
5.1.4 Negotiated Option	22
5.2 General Conditions Applicable to Option to Build	22
5.3 Liquidated Damages	24
5.4 Power System Stabilizers	25
5.5 Equipment Procurement	25
5.5.1.....	26
5.5.2.....	26

5.5.3.....	26
5.6 Construction Commencement	26
5.6.1.....	26
5.6.2.....	26
5.6.3.....	26
5.6.4.....	26
5.7 Work Progress	26
5.8 Information Exchange	27
5.9 Limited Operation	27
5.10 Interconnection Customer's Interconnection Facilities	27
5.10.1 Large Generating Facility and Interconnection Customer's Interconnection Facilities Specifications.....	27
5.10.2 Participating TO's and CAISO's Review.....	27
5.10.3 Interconnection Customer's Interconnection Facilities Construction	28
5.10.4 Interconnection Customer to Meet Requirements of the Participating TO's Interconnection Handbook	28
5.11 Participating TO's Interconnection Facilities Construction	28
5.12 Access Rights	29
5.13 Lands of Other Property Owners	29
5.14 Permits.....	29
5.15 Early Construction of Base Case Facilities	30
5.16 Suspension.....	30
5.17 Taxes.....	30
5.17.1 Interconnection Customer Payments Not Taxable.....	30
5.17.2 Representations and Covenants	31
5.17.3 Indemnification for the Cost Consequences of Current Tax Liability Imposed Upon the Participating TO	31
5.17.4 Tax Gross-Up Amount	32
5.17.5 Private Letter Ruling or Change or Clarification of Law.....	33
5.17.6 Subsequent Taxable Events	33
5.17.7 Contests.....	34
5.17.8 Refund	35
5.17.9 Taxes Other Than Income Taxes.....	36
5.18 Tax Status	36
5.19 Modification.....	36
5.19.1 General	36
5.19.2 Standards.....	37
5.19.3 Modification Costs.....	37
ARTICLE 6. TESTING AND INSPECTION.....	37
6.1 Pre-Commercial Operation Date Testing and Modifications	37
6.2 Post-Commercial Operation Date Testing and Modifications.....	38
6.3 Right to Observe Testing	38
6.4 Right to Inspect.....	38

ARTICLE 7. METERING	38
7.1 General	38
7.2 Check Meters.....	39
7.3 Participating TO Retail Metering	39
ARTICLE 8. COMMUNICATIONS	39
8.1 Interconnection Customer Obligations	39
8.2 Remote Terminal Unit.....	40
8.3 No Annexation	40
ARTICLE 9. OPERATIONS	40
9.1 General	40
9.2 Balancing Authority Area Notification.....	40
9.3 CAISO and Participating TO Obligations	41
9.4 Interconnection Customer Obligations	41
9.5 Start-Up and Synchronization	41
9.6 Reactive Power.....	41
9.6.1 Power Factor Design Criteria	41
9.6.2 Voltage Schedules	42
9.6.2.1 Governors and Regulators.....	42
9.6.3 Payment for Reactive Power.....	43
9.7 Outages and Interruptions	43
9.7.1 Outages	43
9.7.1.1 Outage Authority and Coordination.....	43
9.7.1.2 Outage Schedules	43
9.7.1.3 Outage Restoration.....	44
9.7.2 Interruption of Service	44
9.7.2.1	44
9.7.2.2	44
9.7.2.3	45
9.7.2.4	45
9.7.2.5	45
9.7.3 Under-Frequency and Over-Frequency Conditions.....	45
9.7.4 System Protection and Other Control Requirements	46
9.7.4.1 System Protection Facilities.....	46
9.7.4.2	46
9.7.4.3	46
9.7.4.4	46
9.7.4.5	46
9.7.4.6	46
9.7.5 Requirements for Protection	47
9.7.6 Power Quality.....	47
9.8 Switching and Tagging Rules	47
9.9 Use of Interconnection Facilities by Third Parties	47
9.9.1 Purpose of Interconnection Facilities	48
9.9.2 Third Party Users	48

9.10	Disturbance Analysis Data Exchange	48
ARTICLE 10. MAINTENANCE	48
10.1	Participating TO Obligations	48
10.2	Interconnection Customer Obligations	48
10.3	Coordination	49
10.4	Secondary Systems	49
10.5	Operating and Maintenance Expenses	49
ARTICLE 11. PERFORMANCE OBLIGATION	49
11.1	Interconnection Customer's Interconnection Facilities	49
11.2	Participating TO's Interconnection Facilities	49
11.3	Network Upgrades and Distribution Upgrades	49
11.4	Transmission Credits	50
11.4.1	Repayment of Amounts Advanced for Network Upgrades	50
11.4.2	Special Provisions for Affected Systems	50
11.4.3	51
11.5	Provision of Security	51
11.5.1	51
11.5.2	51
11.5.3	51
11.6	Interconnection Customer Compensation	52
11.6.1	Interconnection Customer Compensation for Actions During Emergency Condition	52
ARTICLE 12. INVOICE	52
12.1	General	52
12.2	Final Invoice	52
12.3	Payment	53
12.4	Disputes	53
ARTICLE 13. EMERGENCIES	53
13.1	[Reserved]	53
13.2	Obligations	53
13.3	Notice	53
13.4	Immediate Action	54
13.5	CAISO and Participating TO Authority	54
13.5.1	General	54
13.5.2	Reduction and Disconnection	55
13.6	Interconnection Customer Authority	55
13.7	Limited Liability	55
ARTICLE 14. REGULATORY REQUIREMENTS AND GOVERNING LAWS	55
14.1	Regulatory Requirements	55
14.2	Governing Law	56
14.2.1	56

14.2.2.....	56
14.2.3.....	56
ARTICLE 15. NOTICES.....	56
15.1 General.....	56
15.2 Billings and Payments.....	56
15.3 Alternative Forms of Notice.....	56
15.4 Operations and Maintenance Notice.....	57
ARTICLE 16. FORCE MAJEURE.....	57
16.1 Force Majeure	57
16.1.1.....	57
16.1.2.....	57
ARTICLE 17. DEFAULT	57
17.1 Default	57
17.1.1 General	57
17.1.2 Right to Terminate.....	58
ARTICLE 18. INDEMNITY, CONSEQUENTIAL DAMAGES, AND INSURANCE	58
18.1 Indemnity	58
18.1.1 Indemnified Party	58
18.1.2 Indemnifying Party	58
18.1.3 Indemnity Procedures	58
18.2 Consequential Damages.....	59
18.3 Insurance.....	59
18.3.1.....	59
18.3.2.....	60
18.3.3.....	60
18.3.4.....	60
18.3.5.....	60
18.3.6.....	60
18.3.7.....	61
18.3.8.....	61
18.3.9.....	61
18.3.10.....	61
18.3.11.....	61
ARTICLE 19. ASSIGNMENT	61
19.1 Assignment	61
ARTICLE 20. SEVERABILITY.....	62
20.1 Severability	62
ARTICLE 21. COMPARABILITY.....	62
21.1 Comparability.....	62

ARTICLE 22. CONFIDENTIALITY	63
22.1 Confidentiality	63
22.1.1 Term	63
22.1.2 Scope	63
22.1.3 Release of Confidential Information	63
22.1.4 Rights	64
22.1.5 No Warranties	64
22.1.6 Standard of Care	64
22.1.7 Order of Disclosure	64
22.1.8 Termination of Agreement	65
22.1.9 Remedies	65
22.1.10 Disclosure to FERC, its Staff, or a State	65
22.1.11	65
ARTICLE 23. ENVIRONMENTAL RELEASES	66
23.1	66
ARTICLE 24. INFORMATION REQUIREMENTS	66
24.1 Information Acquisition.....	66
24.2 Information Submission by Participating TO	66
24.3 Updated Information Submission by Interconnection Customer	67
24.4 Information Supplementation	67
ARTICLE 25. INFORMATION ACCESS AND AUDIT RIGHTS	68
25.1 Information Access	68
25.2 Reporting of Non-Force Majeure Events.....	68
25.3 Audit Rights	69
25.3.1	69
25.3.2.....	69
25.4 Audit Rights Periods	69
25.4.1 Audit Rights Period for Construction-Related Accounts and Records	69
25.4.2 Audit Rights Period for All Other Accounts and Records	69
25.5 Audit Results.....	70
25.5.1	70
ARTICLE 26. SUBCONTRACTORS	70
26.1 General	70
26.2 Responsibility of Principal	70
26.3 No Limitation by Insurance	70
ARTICLE 27. DISPUTES	71
27.1 Submission	71
27.2 External Arbitration Procedures	71

27.3	Arbitration Decisions	71
27.4	Costs.....	72
ARTICLE 28.	REPRESENTATIONS, WARRANTIES AND COVENANTS	72
28.1	General.....	72
28.1.1	Good Standing	72
28.1.2	Authority.....	72
28.1.3	No Conflict	72
28.1.4	Consent and Approval.....	73
ARTICLE 29.	[RESERVED].....	73
ARTICLE 30.	MISCELLANEOUS.....	73
30.1	Binding Effect.....	73
30.2	Conflicts.....	73
30.3	Rules of Interpretation.....	73
30.4	Entire Agreement.....	74
30.5	No Third Party Beneficiaries	74
30.6	Waiver.....	74
30.7	Headings.....	74
30.8	Multiple Counterparts.....	74
30.9	Amendment	74
30.10	Modification by the Parties.....	74
30.11	Reservation of Rights.....	75
30.12	No Partnership.....	76
30.13	Joint and Several Obligations	76
Appendices	78
Appendix A	Interconnection Facilities, Network Upgrades and Distribution Upgrades	
Appendix B	Milestones	
Appendix C	Interconnection Details	
Appendix D	Security Arrangements Details	
Appendix E	Commercial Operation Date	
Appendix F	Addresses for Delivery of Notices and Billings	
Appendix G	Reliability Management System Agreement	
Appendix H	Interconnection Requirements for a Wind Generating Plant	

STANDARD LARGE GENERATOR INTERCONNECTION AGREEMENT

GRANITE WIND, LLC

SOUTHERN CALIFORNIA EDISON COMPANY

CALIFORNIA INDEPENDENT SYSTEM OPERATOR CORPORATION

THIS STANDARD LARGE GENERATOR INTERCONNECTION AGREEMENT ("LGIA") is made and entered into this ____ day of _____ 2010, by and among Granite Wind, LLC, a corporation organized and existing under the laws of the State/Commonwealth of Delaware ("**Interconnection Customer**" with a Large Generating Facility), Southern California Edison Company, a corporation organized and existing under the laws of the State of California ("**Participating TO**"), and California Independent System Operator Corporation, a California nonprofit public benefit corporation organized and existing under the laws of the State of California ("**CAISO**"). Interconnection Customer, Participating TO, and CAISO each may be referred to as a "Party" or collectively as the "Parties."

RECITALS

WHEREAS, CAISO exercises Operational Control over the CAISO Controlled Grid; and

WHEREAS, the Participating TO owns, operates, and maintains the Participating TO's Transmission System; and

WHEREAS, Interconnection Customer intends to own, lease and/or control and operate the Generating Facility identified as a Large Generating Facility in Appendix C to this LGIA; and

WHEREAS, Interconnection Customer, Participating TO, and CAISO have agreed to enter into this LGIA for the purpose of interconnecting the Large Generating Facility with the Participating TO's Transmission System;

NOW, THEREFORE, in consideration of and subject to the mutual covenants contained herein, it is agreed:

When used in this LGIA, terms with initial capitalization that are not defined in Article 1 shall have the meanings specified in the Article in which they are used.

ARTICLE 1. DEFINITIONS

Adverse System Impact shall mean the negative effects due to technical or operational limits on conductors or equipment being exceeded that may compromise the safety and reliability of the electric system.

Affected System shall mean an electric system other than the CAISO Controlled Grid that may be affected by the proposed interconnection, including the Participating TO's electric system that is not part of the CAISO Controlled Grid.

Affiliate shall mean, with respect to a corporation, partnership or other entity, each such other corporation, partnership or other entity that directly or indirectly, through one or more intermediaries, controls, is controlled by, or is under common control with, such corporation, partnership or other entity.

Applicable Laws and Regulations shall mean all duly promulgated applicable federal, state and local laws, regulations, rules, ordinances, codes, decrees, judgments, directives, or judicial or administrative orders, permits and other duly authorized actions of any Governmental Authority.

Applicable Reliability Council shall mean the Western Electricity Coordinating Council or its successor.

Applicable Reliability Standards shall mean the requirements and guidelines of NERC, the Applicable Reliability Council, and the Balancing Authority Area of the Participating TO's Transmission System to which the Generating Facility is directly connected, including requirements adopted pursuant to Section 215 of the Federal Power Act .

Balancing Authority shall mean the responsible entity that integrates resource plans ahead of time, maintains load-interchange-generation balance within a Balancing Authority Area, and supports Interconnection frequency in real time.

Balancing Authority Area shall mean the collection of generation, transmission, and loads within the metered boundaries of the Balancing Authority. The Balancing Authority maintains load-resource balance within this area.

Base Case shall mean the base case power flow, short circuit, and stability data bases used for the Interconnection Studies.

Breach shall mean the failure of a Party to perform or observe any material term or condition of this LGIA.

Breaching Party shall mean a Party that is in Breach of this LGIA.

Business Day shall mean Monday through Friday, excluding federal holidays and the day after Thanksgiving Day.

Calendar Day shall mean any day including Saturday, Sunday or a federal holiday.

Commercial Operation shall mean the status of an Electric Generating Unit at a Generating Facility that has commenced generating electricity for sale, excluding electricity generated during Trial Operation.

Commercial Operation Date of an Electric Generating Unit shall mean the date on which the Electric Generating Unit at the Generating Facility commences Commercial Operation as agreed to by the applicable Participating TO and the Interconnection Customer pursuant to Appendix E to this LGIA.

Confidential Information shall mean any confidential, proprietary or trade secret information of a plan, specification, pattern, procedure, design, device, list, concept, policy or compilation relating to the present or planned business of a Party, which is designated as confidential by the Party supplying the information, whether conveyed orally, electronically, in writing, through inspection, or otherwise, subject to Article 22.1.2.

Default shall mean the failure of a Breaching Party to cure its Breach in accordance with Article 17 of this LGIA.

Distribution System shall mean those non-CAISO-controlled transmission and distribution facilities owned by the Participating TO.

Distribution Upgrades shall mean the additions, modifications, and upgrades to the Participating TO's Distribution System. Distribution Upgrades do not include Interconnection Facilities.

Effective Date shall mean the date on which this LGIA becomes effective upon execution by the Parties subject to acceptance by FERC, or if filed unexecuted, upon the date specified by FERC.

Electric Generating Unit shall mean an individual electric generator and its associated plant and apparatus whose electrical output is capable of being separately identified and metered.

Emergency Condition shall mean a condition or situation: (1) that in the judgment of the Party making the claim is imminently likely to endanger life or property; or (2) that, in the case of the CAISO, is imminently likely (as determined in a non-discriminatory manner) to cause a material adverse effect on the security of, or damage to, the CAISO Controlled Grid or the electric systems of others to which the CAISO Controlled Grid is directly connected; (3) that, in the case of the Participating TO, is

imminently likely (as determined in a non-discriminatory manner) to cause a material adverse effect on the security of, or damage to, the Participating TO's Transmission System, Participating TO's Interconnection Facilities, Distribution System, or the electric systems of others to which the Participating TO's electric system is directly connected; or (4) that, in the case of the Interconnection Customer, is imminently likely (as determined in a non-discriminatory manner) to cause a material adverse effect on the security of, or damage to, the Generating Facility or Interconnection Customer's Interconnection Facilities. System restoration and black start shall be considered Emergency Conditions; provided, that Interconnection Customer is not obligated by this LGIA to possess black start capability.

Environmental Law shall mean Applicable Laws or Regulations relating to pollution or protection of the environment or natural resources.

Federal Power Act shall mean the Federal Power Act, as amended, 16 U.S.C. §§ 791a *et seq.*

FERC shall mean the Federal Energy Regulatory Commission or its successor.

Force Majeure shall mean any act of God, labor disturbance, act of the public enemy, war, insurrection, riot, fire, storm or flood, explosion, breakage or accident to machinery or equipment, any order, regulation or restriction imposed by governmental, military or lawfully established civilian authorities, or any other cause beyond a Party's control. A Force Majeure event does not include acts of negligence or intentional wrongdoing by the Party claiming Force Majeure.

Generating Facility shall mean the Interconnection Customer's Electric Generating Unit(s) used for the production of electricity identified in the Interconnection Customer's Interconnection Request, but shall not include the Interconnection Customer's Interconnection Facilities.

Generating Facility Capacity shall mean the net capacity of the Generating Facility and the aggregate net capacity of the Generating Facility where it includes multiple energy production devices.

Good Utility Practice shall mean any of the practices, methods and acts engaged in or approved by a significant portion of the electric utility industry during the relevant time period, or any of the practices, methods and acts which, in the exercise of reasonable judgment in light of the facts known at the time the decision was made, could have been expected to accomplish the desired result at a reasonable cost consistent with good business practices, reliability, safety and expedition. Good Utility Practice is not intended to be any one of a number of the optimum practices, methods, or acts to the exclusion of all others, but rather to be acceptable practices, methods, or acts generally accepted in the region.

Governmental Authority shall mean any federal, state, local or other governmental, regulatory or administrative agency, court, commission, department, board, or other governmental subdivision, legislature, rulemaking board, tribunal, or other governmental authority having jurisdiction over the Parties, their respective facilities, or the respective services they provide, and exercising or entitled to exercise any administrative, executive, police, or taxing authority or power; provided, however, that such term does not include the Interconnection Customer, CAISO, Participating TO, or any Affiliate thereof.

Hazardous Substances shall mean any chemicals, materials or substances defined as or included in the definition of “hazardous substances,” “hazardous wastes,” “hazardous materials,” “hazardous constituents,” “restricted hazardous materials,” “extremely hazardous substances,” “toxic substances,” “radioactive substances,” “contaminants,” “pollutants,” “toxic pollutants” or words of similar meaning and regulatory effect under any applicable Environmental Law, or any other chemical, material or substance, exposure to which is prohibited, limited or regulated by any applicable Environmental Law.

Initial Synchronization Date shall mean the date upon which an Electric Generating Unit is initially synchronized and upon which Trial Operation begins.

In-Service Date shall mean the date upon which the Interconnection Customer reasonably expects it will be ready to begin use of the Participating TO’s Interconnection Facilities to obtain back feed power.

Interconnection Customer's Interconnection Facilities shall mean all facilities and equipment, as identified in Appendix A of this LGIA, that are located between the Generating Facility and the Point of Change of Ownership, including any modification, addition, or upgrades to such facilities and equipment necessary to physically and electrically interconnect the Generating Facility to the Participating TO’s Transmission System. Interconnection Customer's Interconnection Facilities are sole use facilities.

Interconnection Facilities shall mean the Participating TO’s Interconnection Facilities and the Interconnection Customer's Interconnection Facilities. Collectively, Interconnection Facilities include all facilities and equipment between the Generating Facility and the Point of Interconnection, including any modification, additions or upgrades that are necessary to physically and electrically interconnect the Generating Facility to the Participating TO’s Transmission System. Interconnection Facilities are sole use facilities and shall not include Distribution Upgrades, Stand Alone Network Upgrades or Network Upgrades.

Interconnection Facilities Study shall mean the study conducted or caused to be performed by the CAISO, in coordination with the applicable Participating TO(s), or a third party consultant for the Interconnection Customer to determine a list of facilities (including the Participating TO’s Interconnection Facilities, Network Upgrades, and

Distribution Upgrades), the cost of those facilities, and the time required to interconnect the Generating Facility with the Participating TO's Transmission System.

Interconnection Facilities Study Agreement shall mean the agreement between the Interconnection Customer and the CAISO for conducting the Interconnection Facilities Study.

Interconnection Feasibility Study shall mean the preliminary evaluation conducted or caused to be performed by the CAISO, in coordination with the applicable Participating TO(s), or a third party consultant for the Interconnection Customer of the system impact and cost of interconnecting the Generating Facility to the Participating TO's Transmission System.

Interconnection Handbook shall mean a handbook, developed by the Participating TO and posted on the Participating TO's web site or otherwise made available by the Participating TO, describing technical and operational requirements for wholesale generators and loads connected to the Participating TO's portion of the CAISO Controlled Grid, as such handbook may be modified or superseded from time to time. Participating TO's standards contained in the Interconnection Handbook shall be deemed consistent with Good Utility Practice and Applicable Reliability Standards. In the event of a conflict between the terms of this LGIA and the terms of the Participating TO's Interconnection Handbook, the terms in this LGIA shall apply.

Interconnection Request shall mean a request, in the form of Appendix 1 to the Standard Large Generator Interconnection Procedures, in accordance with the CAISO Tariff.

Interconnection Service shall mean the service provided by the Participating TO and CAISO associated with interconnecting the Interconnection Customer's Generating Facility to the Participating TO's Transmission System and enabling the CAISO Controlled Grid to receive electric energy and capacity from the Generating Facility at the Point of Interconnection, pursuant to the terms of this LGIA, the Participating TO's Transmission Owner Tariff, and the CAISO Tariff.

Interconnection Study shall mean any of the following studies: the Interconnection Feasibility Study, the Interconnection System Impact Study, and the Interconnection Facilities Study conducted or caused to be performed by the CAISO, in coordination with the applicable Participating TO(s), or a third party consultant for the Interconnection Customer pursuant to the Standard Large Generator Interconnection Procedures.

Interconnection System Impact Study shall mean the engineering study conducted or caused to be performed by the CAISO, in coordination with the applicable Participating TO(s), or a third party consultant for the Interconnection Customer that evaluates the impact of the proposed interconnection on the safety and reliability of the Participating TO's Transmission System and, if applicable, an Affected System. The

study shall identify and detail the system impacts that would result if the Generating Facility were interconnected without project modifications or system modifications, focusing on the Adverse System Impacts identified in the Interconnection Feasibility Study, or to study potential impacts, including but not limited to those identified in the Scoping Meeting as described in the Standard Large Generator Interconnection Procedures.

IRS shall mean the Internal Revenue Service.

CAISO Controlled Grid shall mean the system of transmission lines and associated facilities of the parties to the Transmission Control Agreement that have been placed under the CAISO's Operational Control.

CAISO Tariff shall mean the CAISO's tariff, as filed with FERC, and as amended or supplemented from time to time, or any successor tariff.

Large Generating Facility shall mean a Generating Facility having a Generating Facility Capacity of more than 20 MW.

Loss shall mean any and all damages, losses, and claims, including claims and actions relating to injury to or death of any person or damage to property, demand, suits, recoveries, costs and expenses, court costs, attorney fees, and all other obligations by or to third parties.

Material Modification shall mean those modifications that have a material impact on the cost or timing of any Interconnection Request or any other valid interconnection request with a later queue priority date.

Metering Equipment shall mean all metering equipment installed or to be installed for measuring the output of the Generating Facility pursuant to this LGIA at the metering points, including but not limited to instrument transformers, MWh-meters, data acquisition equipment, transducers, remote terminal unit, communications equipment, phone lines, and fiber optics.

NERC shall mean the North American Electric Reliability Council or its successor organization.

Network Upgrades shall be Participating TO's Delivery Network Upgrades and Participating TO's Reliability Network Upgrades.

Operational Control shall mean the rights of the CAISO under the Transmission Control Agreement and the CAISO Tariff to direct the parties to the Transmission Control Agreement how to operate their transmission lines and facilities and other electric plant affecting the reliability of those lines and facilities for the purpose of affording comparable non-discriminatory transmission access and meeting applicable reliability criteria.

Participating TO's Delivery Network Upgrades shall mean the additions, modifications, and upgrades to the Participating TO's Transmission System at or beyond the Point of Interconnection, other than Reliability Network Upgrades, identified in the Interconnection Studies, as identified in Appendix A, to relieve constraints on the CAISO Controlled Grid.

Participating TO's Interconnection Facilities shall mean all facilities and equipment owned, controlled or operated by the Participating TO from the Point of Change of Ownership to the Point of Interconnection as identified in Appendix A to this LGIA, including any modifications, additions or upgrades to such facilities and equipment. Participating TO's Interconnection Facilities are sole use facilities and shall not include Distribution Upgrades, Stand Alone Network Upgrades or Network Upgrades.

Participating TO's Reliability Network Upgrades shall mean the additions, modifications, and upgrades to the Participating TO's Transmission System at or beyond the Point of Interconnection, identified in the Interconnection Studies, as identified in Appendix A, necessary to interconnect the Large Generating Facility safely and reliably to the Participating TO's Transmission System, which would not have been necessary but for the interconnection of the Large Generating Facility, including additions, modifications, and upgrades necessary to remedy short circuit or stability problems resulting from the interconnection of the Large Generating Facility to the Participating TO's Transmission System. Participating TO's Reliability Network Upgrades also include, consistent with Applicable Reliability Council practice, the Participating TO's facilities necessary to mitigate any adverse impact the Large Generating Facility's interconnection may have on a path's Applicable Reliability Council rating.

Participating TO's Transmission System shall mean the facilities owned and operated by the Participating TO and that have been placed under the CAISO's Operational Control, which facilities form part of the CAISO Controlled Grid.

Party or Parties shall mean the Participating TO, CAISO, Interconnection Customer or the applicable combination of the above.

Point of Change of Ownership shall mean the point, as set forth in Appendix A to this LGIA, where the Interconnection Customer's Interconnection Facilities connect to the Participating TO's Interconnection Facilities.

Point of Interconnection shall mean the point, as set forth in Appendix A to this LGIA, where the Interconnection Facilities connect to the Participating TO's Transmission System.

Qualifying Facility shall mean a qualifying cogeneration facility or qualifying small power production facility, as defined in the Code of Federal Regulations, Title 18, Part 292 (18 C.F.R. §292).

QF PGA shall mean a Qualifying Facility Participating Generator Agreement specifying the special provisions for the operating relationship between a Qualifying Facility and the CAISO, a pro forma version of which is set forth in Appendix B.3 of the CAISO Tariff.

Reasonable Efforts shall mean, with respect to an action required to be attempted or taken by a Party under this LGIA, efforts that are timely and consistent with Good Utility Practice and are otherwise substantially equivalent to those a Party would use to protect its own interests.

Scoping Meeting shall mean the meeting among representatives of the Interconnection Customer, the Participating TO(s), other Affected Systems, and the CAISO conducted for the purpose of discussing alternative interconnection options, to exchange information including any transmission data and earlier study evaluations that would be reasonably expected to impact such interconnection options, to analyze such information, and to determine the potential feasible Points of Interconnection.

Stand Alone Network Upgrades shall mean Network Upgrades that the Interconnection Customer may construct without affecting day-to-day operations of the CAISO Controlled Grid or Affected Systems during their construction. The Participating TO, the CAISO, and the Interconnection Customer must agree as to what constitutes Stand Alone Network Upgrades and identify them in Appendix A to this LGIA.

Standard Large Generator Interconnection Procedures (LGIP) shall mean the CAISO protocol that sets forth the interconnection procedures applicable to an Interconnection Request pertaining to a Large Generating Facility that is included in CAISO Tariff Appendix U.

System Protection Facilities shall mean the equipment, including necessary protection signal communications equipment, that protects (1) the Participating TO's Transmission System, Participating TO's Interconnection Facilities, CAISO Controlled Grid, and Affected Systems from faults or other electrical disturbances occurring at the Generating Facility and (2) the Generating Facility from faults or other electrical system disturbances occurring on the CAISO Controlled Grid, Participating TO's Interconnection Facilities, and Affected Systems or on other delivery systems or other generating systems to which the CAISO Controlled Grid is directly connected.

Transmission Control Agreement shall mean CAISO FERC Electric Tariff No. 7.

Trial Operation shall mean the period during which the Interconnection Customer is engaged in on-site test operations and commissioning of an Electric Generating Unit prior to Commercial Operation.

ARTICLE 2. EFFECTIVE DATE, TERM AND TERMINATION

- 2.1 Effective Date.** This LGIA shall become effective upon execution by the Parties subject to acceptance by FERC (if applicable), or if filed unexecuted, upon the date specified by FERC. The CAISO and Participating TO shall promptly file this LGIA with FERC upon execution in accordance with Article 3.1, if required.
- 2.2 Term of Agreement.** Subject to the provisions of Article 2.3, this LGIA shall remain in effect for a period of thirty (30) years from the Effective Date and shall be automatically renewed for each successive one-year period thereafter.
- 2.3 Termination Procedures.**
- 2.3.1 Written Notice.** This LGIA may be terminated by the Interconnection Customer after giving the CAISO and the Participating TO ninety (90) Calendar Days advance written notice, or by the CAISO and the Participating TO notifying FERC after the Generating Facility permanently ceases Commercial Operation.
- 2.3.2 Default.** A Party may terminate this LGIA in accordance with Article 17.
- 2.3.3 Suspension of Work.** This LGIA may be deemed terminated in accordance with Article 5.16.
- 2.3.4** Notwithstanding Articles 2.3.1, 2.3.2, and 2.3.3, no termination shall become effective until the Parties have complied with all Applicable Laws and Regulations applicable to such termination, including the filing with FERC of a notice of termination of this LGIA, which notice has been accepted for filing by FERC.
- 2.4 Termination Costs.** If this LGIA terminates pursuant to Article 2.3 above, the Interconnection Customer shall pay all costs incurred or irrevocably committed to be incurred in association with the Interconnection Customer's interconnection (including any cancellation costs relating to orders or contracts for Interconnection Facilities and equipment) and other expenses, including any Network Upgrades and Distribution Upgrades for which the Participating TO or CAISO has incurred expenses or has irrevocably committed to incur expenses and has not been reimbursed by the Interconnection Customer, as of the date of the other Parties' receipt of the notice of termination, subject to the limitations set forth in this Article 2.4. However, to the extent that the costs of the Participating TO's Network Upgrades have received Abandoned Plant Approval, the

Interconnection Customer shall not be responsible for those charges. Nothing in this Article 2.4 shall limit the Parties' rights under Article 17.

- 2.4.1** Notwithstanding the foregoing, in the event of termination by a Party, all Parties shall use commercially Reasonable Efforts to mitigate the costs, damages and charges arising as a consequence of termination. With respect to any portion of the Participating TO's Interconnection Facilities that have not yet been constructed or installed, the Participating TO shall to the extent possible and with the Interconnection Customer's authorization cancel any pending orders of, or return, any materials or equipment for, or contracts for construction of, such facilities; provided that in the event the Interconnection Customer elects not to authorize such cancellation, the Interconnection Customer shall assume all payment obligations with respect to such materials, equipment, and contracts, and the Participating TO shall deliver such material and equipment, and, if necessary, assign such contracts, to the Interconnection Customer as soon as practicable, at the Interconnection Customer's expense. To the extent that the Interconnection Customer has already paid the Participating TO for any or all such costs of materials or equipment not taken by the Interconnection Customer, the Participating TO shall promptly refund such amounts to the Interconnection Customer, less any costs, including penalties, incurred by the Participating TO to cancel any pending orders of or return such materials, equipment, or contracts.
- 2.4.2** The Participating TO may, at its option, retain any portion of such materials, equipment, or facilities that the Interconnection Customer chooses not to accept delivery of, in which case the Participating TO shall be responsible for all costs associated with procuring such materials, equipment, or facilities.
- 2.4.3** With respect to any portion of the Interconnection Facilities, and any other facilities already installed or constructed pursuant to the terms of this LGIA, Interconnection Customer shall be responsible for all costs associated with the removal, relocation or other disposition or retirement of such materials, equipment, or facilities.
- 2.5 Disconnection.** Upon termination of this LGIA, the Parties will take all appropriate steps to disconnect the Large Generating Facility from the Participating TO's Transmission System. All costs required to effectuate such disconnection shall be borne by the terminating Party, unless such termination resulted from the non-terminating Party's Default of this LGIA or such non-terminating Party otherwise is responsible for these costs under this LGIA.
- 2.6 Survival.** This LGIA shall continue in effect after termination to the extent necessary to provide for final billings and payments and for costs incurred hereunder, including billings and payments pursuant to this LGIA; to permit the

determination and enforcement of liability and indemnification obligations arising from acts or events that occurred while this LGIA was in effect; and to permit each Party to have access to the lands of the other Parties pursuant to this LGIA or other applicable agreements, to disconnect, remove or salvage its own facilities and equipment.

ARTICLE 3. REGULATORY FILINGS AND CAISO TARIFF COMPLIANCE

- 3.1 Filing.** The Participating TO and the CAISO shall file this LGIA (and any amendment hereto) with the appropriate Governmental Authority(ies), if required. The Interconnection Customer may request that any information so provided be subject to the confidentiality provisions of Article 22. If the Interconnection Customer has executed this LGIA, or any amendment thereto, the Interconnection Customer shall reasonably cooperate with the Participating TO and CAISO with respect to such filing and to provide any information reasonably requested by the Participating TO or CAISO needed to comply with applicable regulatory requirements.
- 3.2 Agreement Subject to CAISO Tariff.** The Interconnection Customer will comply with all applicable provisions of the CAISO Tariff, including the LGIP.
- 3.3 Relationship Between this LGIA and the CAISO Tariff.** With regard to rights and obligations between the Participating TO and the Interconnection Customer, if and to the extent a matter is specifically addressed by a provision of this LGIA (including any appendices, schedules or other attachments to this LGIA), the provisions of this LGIA shall govern. If and to the extent a provision of this LGIA is inconsistent with the CAISO Tariff and dictates rights and obligations between the CAISO and the Participating TO or the CAISO and the Interconnection Customer, the CAISO Tariff shall govern.
- 3.4 Relationship Between this LGIA and the QF PGA.** With regard to the rights and obligations of a Qualifying Facility that has entered into a QF PGA with the CAISO and has entered into this LGIA, if and to the extent a matter is specifically addressed by a provision of the QF PGA that is inconsistent with this LGIA, the terms of the QF PGA shall govern.

ARTICLE 4. SCOPE OF SERVICE

- 4.1 Interconnection Service.** Interconnection Service allows the Interconnection Customer to connect the Large Generating Facility to the Participating TO's Transmission System and be eligible to deliver the Large Generating Facility's output using the available capacity of the CAISO Controlled Grid. To the extent the Interconnection Customer wants to receive Interconnection Service, the

Participating TO shall construct facilities identified in Appendices A and C that the Participating TO is responsible to construct.

Interconnection Service does not necessarily provide the Interconnection Customer with the capability to physically deliver the output of its Large Generating Facility to any particular load on the CAISO Controlled Grid without incurring congestion costs. In the event of transmission constraints on the CAISO Controlled Grid, the Interconnection Customer's Large Generating Facility shall be subject to the applicable congestion management procedures in the CAISO Tariff in the same manner as all other resources.

- 4.2 Provision of Service.** The Participating TO and the CAISO shall provide Interconnection Service for the Large Generating Facility.
- 4.3 Performance Standards.** Each Party shall perform all of its obligations under this LGIA in accordance with Applicable Laws and Regulations, Applicable Reliability Standards, and Good Utility Practice, and to the extent a Party is required or prevented or limited in taking any action by such regulations and standards, such Party shall not be deemed to be in Breach of this LGIA for its compliance therewith. If such Party is the CAISO or Participating TO, then that Party shall amend the LGIA and submit the amendment to FERC for approval.
- 4.4 No Transmission Service.** The execution of this LGIA does not constitute a request for, nor the provision of, any transmission service under the CAISO Tariff, and does not convey any right to deliver electricity to any specific customer or point of delivery.
- 4.5 Interconnection Customer Provided Services.** The services provided by Interconnection Customer under this LGIA are set forth in Article 9.6 and Article 13.5.1. Interconnection Customer shall be paid for such services in accordance with Article 11.6.

ARTICLE 5. INTERCONNECTION FACILITIES ENGINEERING, PROCUREMENT, AND CONSTRUCTION

Interconnection Facilities, Network Upgrades, and Distribution Upgrades shall be studied, designed, and constructed pursuant to Good Utility Practice. Such studies, design and construction shall be based on the assumed accuracy and completeness of all technical information received by the Participating TO and the CAISO from the Interconnection Customer associated with interconnecting the Large Generating Facility.

- 5.1 Options.** Unless otherwise mutually agreed among the Parties, the Interconnection Customer shall select the In-Service Date, Initial Synchronization Date, and Commercial Operation Date; and either Standard Option or Alternate

Option set forth below for completion of the Participating TO's Interconnection Facilities and Network Upgrades as set forth in Appendix A, Interconnection Facilities, Network Upgrades, and Distribution Upgrades, and such dates and selected option shall be set forth in Appendix B, Milestones.

5.1.1 Standard Option. The Participating TO shall design, procure, and construct the Participating TO's Interconnection Facilities, Network Upgrades, and Distribution Upgrades, using Reasonable Efforts to complete the Participating TO's Interconnection Facilities, Network Upgrades, and Distribution Upgrades by the dates set forth in Appendix B, Milestones. The Participating TO shall not be required to undertake any action which is inconsistent with its standard safety practices, its material and equipment specifications, its design criteria and construction procedures, its labor agreements, and Applicable Laws and Regulations. In the event the Participating TO reasonably expects that it will not be able to complete the Participating TO's Interconnection Facilities, Network Upgrades, and Distribution Upgrades by the specified dates, the Participating TO shall promptly provide written notice to the Interconnection Customer and the CAISO and shall undertake Reasonable Efforts to meet the earliest dates thereafter.

5.1.2 Alternate Option. If the dates designated by the Interconnection Customer are acceptable to the Participating TO, the Participating TO shall so notify the Interconnection Customer within thirty (30) Calendar Days, and shall assume responsibility for the design, procurement and construction of the Participating TO's Interconnection Facilities by the designated dates.

If the Participating TO subsequently fails to complete the Participating TO's Interconnection Facilities by the In-Service Date, to the extent necessary to provide back feed power; or fails to complete Network Upgrades by the Initial Synchronization Date to the extent necessary to allow for Trial Operation at full power output, unless other arrangements are made by the Parties for such Trial Operation; or fails to complete the Network Upgrades by the Commercial Operation Date, as such dates are reflected in Appendix B, Milestones; the Participating TO shall pay the Interconnection Customer liquidated damages in accordance with Article 5.3, Liquidated Damages, provided, however, the dates designated by the Interconnection Customer shall be extended day for day for each day that the CAISO refuses to grant clearances to install equipment.

5.1.3 Option to Build. If the dates designated by the Interconnection Customer are not acceptable to the Participating TO, the Participating TO shall so notify the Interconnection Customer within thirty (30) Calendar Days, and unless the Parties agree otherwise, the Interconnection Customer shall have the option to assume responsibility for the design, procurement and

construction of the Participating TO's Interconnection Facilities and Stand Alone Network Upgrades. If the Interconnection Customer elects to exercise its option to assume responsibility for the design, procurement and construction of the Participating TO's Interconnection Facilities and Stand Alone Network Upgrades, it shall so notify the Participating TO within thirty (30) Calendar Days of receipt of the Participating TO's notification that the designated dates are not acceptable to the Participating TO. The Participating TO, CAISO, and Interconnection Customer must agree as to what constitutes Stand Alone Network Upgrades and identify such Stand Alone Network Upgrades in Appendix A to this LGIA. Except for Stand Alone Network Upgrades, the Interconnection Customer shall have no right to construct Network Upgrades under this option.

5.1.4 Negotiated Option. If the Interconnection Customer elects not to exercise its option under Article 5.1.3, Option to Build, the Interconnection Customer shall so notify the Participating TO within thirty (30) Calendar Days of receipt of the Participating TO's notification that the designated dates are not acceptable to the Participating TO, and the Parties shall in good faith attempt to negotiate terms and conditions (including revision of the specified dates and liquidated damages, the provision of incentives or the procurement and construction of a portion of the Participating TO's Interconnection Facilities and Stand Alone Network Upgrades by the Interconnection Customer) pursuant to which the Participating TO is responsible for the design, procurement and construction of the Participating TO's Interconnection Facilities and Network Upgrades. If the Parties are unable to reach agreement on such terms and conditions, the Participating TO shall assume responsibility for the design, procurement and construction of the Participating TO's Interconnection Facilities and Network Upgrades pursuant to Article 5.1.1, Standard Option.

5.2 General Conditions Applicable to Option to Build. If the Interconnection Customer assumes responsibility for the design, procurement and construction of the Participating TO's Interconnection Facilities and Stand Alone Network Upgrades,

(1) the Interconnection Customer shall engineer, procure equipment, and construct the Participating TO's Interconnection Facilities and Stand Alone Network Upgrades (or portions thereof) using Good Utility Practice and using standards and specifications provided in advance by the Participating TO;

(2) the Interconnection Customer's engineering, procurement and construction of the Participating TO's Interconnection Facilities and Stand Alone Network Upgrades shall comply with all requirements of law to which the Participating TO would be subject in the engineering,

procurement or construction of the Participating TO's Interconnection Facilities and Stand Alone Network Upgrades;

(3) the Participating TO shall review, and the Interconnection Customer shall obtain the Participating TO's approval of, the engineering design, equipment acceptance tests, and the construction of the Participating TO's Interconnection Facilities and Stand Alone Network Upgrades, which approval shall not be unreasonably withheld, and the CAISO may, at its option, review the engineering design, equipment acceptance tests, and the construction of the Participating TO's Interconnection Facilities and Stand Alone Network Upgrades;

(4) prior to commencement of construction, the Interconnection Customer shall provide to the Participating TO, with a copy to the CAISO for informational purposes, a schedule for construction of the Participating TO's Interconnection Facilities and Stand Alone Network Upgrades, and shall promptly respond to requests for information from the Participating TO;

(5) at any time during construction, the Participating TO shall have the right to gain unrestricted access to the Participating TO's Interconnection Facilities and Stand Alone Network Upgrades and to conduct inspections of the same;

(6) at any time during construction, should any phase of the engineering, equipment procurement, or construction of the Participating TO's Interconnection Facilities and Stand Alone Network Upgrades not meet the standards and specifications provided by the Participating TO, the Interconnection Customer shall be obligated to remedy deficiencies in that portion of the Participating TO's Interconnection Facilities and Stand Alone Network Upgrades;

(7) the Interconnection Customer shall indemnify the CAISO and Participating TO for claims arising from the Interconnection Customer's construction of the Participating TO's Interconnection Facilities and Stand Alone Network Upgrades under the terms and procedures applicable to Article 18.1 Indemnity;

(8) the Interconnection Customer shall transfer control of the Participating TO's Interconnection Facilities to the Participating TO and shall transfer Operational Control of Stand Alone Network Upgrades to the CAISO;

(9) unless the Parties otherwise agree, the Interconnection Customer shall transfer ownership of the Participating TO's Interconnection Facilities and Stand Alone Network Upgrades to the Participating TO. As soon as reasonably practicable, but within twelve months after completion of the

construction of the Participating TO's Interconnection Facilities and Stand Alone Network Upgrades, the Interconnection Customer shall provide an invoice of the final cost of the construction of the Participating TO's Interconnection Facilities and Stand Alone Network Upgrades to the Participating TO, which invoice shall set forth such costs in sufficient detail to enable the Participating TO to reflect the proper costs of such facilities in its transmission rate base and to identify the investment upon which refunds will be provided;

(10) the Participating TO shall accept for operation and maintenance the Participating TO's Interconnection Facilities and Stand Alone Network Upgrades to the extent engineered, procured, and constructed in accordance with this Article 5.2; and

(11) the Interconnection Customer's engineering, procurement and construction of the Participating TO's Interconnection Facilities and Stand Alone Network Upgrades shall comply with all requirements of the "Option to Build" conditions set forth in Appendix C. Interconnection Customer shall deliver to the Participating TO "as-built" drawings, information, and any other documents that are reasonably required by the Participating TO to assure that the Interconnection Facilities and Stand-Alone Network Upgrades are built to the standards and specifications required by the Participating TO.

5.3 Liquidated Damages. The actual damages to the Interconnection Customer, in the event the Participating TO's Interconnection Facilities or Network Upgrades are not completed by the dates designated by the Interconnection Customer and accepted by the Participating TO pursuant to subparagraphs 5.1.2 or 5.1.4, above, may include Interconnection Customer's fixed operation and maintenance costs and lost opportunity costs. Such actual damages are uncertain and impossible to determine at this time. Because of such uncertainty, any liquidated damages paid by the Participating TO to the Interconnection Customer in the event that the Participating TO does not complete any portion of the Participating TO's Interconnection Facilities or Network Upgrades by the applicable dates, shall be an amount equal to $\frac{1}{2}$ of 1 percent per day of the actual cost of the Participating TO's Interconnection Facilities and Network Upgrades, in the aggregate, for which the Participating TO has assumed responsibility to design, procure and construct.

However, in no event shall the total liquidated damages exceed 20 percent of the actual cost of the Participating TO's Interconnection Facilities and Network Upgrades for which the Participating TO has assumed responsibility to design, procure, and construct. The foregoing payments will be made by the Participating TO to the Interconnection Customer as just compensation for the damages caused to the Interconnection Customer, which actual damages are uncertain and impossible to determine at this time, and as reasonable liquidated

damages, but not as a penalty or a method to secure performance of this LGIA. Liquidated damages, when the Parties agree to them, are the exclusive remedy for the Participating TO's failure to meet its schedule.

No liquidated damages shall be paid to the Interconnection Customer if: (1) the Interconnection Customer is not ready to commence use of the Participating TO's Interconnection Facilities or Network Upgrades to take the delivery of power for the Electric Generating Unit's Trial Operation or to export power from the Electric Generating Unit on the specified dates, unless the Interconnection Customer would have been able to commence use of the Participating TO's Interconnection Facilities or Network Upgrades to take the delivery of power for Electric Generating Unit's Trial Operation or to export power from the Electric Generating Unit, but for the Participating TO's delay; (2) the Participating TO's failure to meet the specified dates is the result of the action or inaction of the Interconnection Customer or any other interconnection customer who has entered into an interconnection agreement with the CAISO and/or Participating TO, action or inaction by the CAISO, or any cause beyond the Participating TO's reasonable control or reasonable ability to cure; (3) the Interconnection Customer has assumed responsibility for the design, procurement and construction of the Participating TO's Interconnection Facilities and Stand Alone Network Upgrades; or (4) the Parties have otherwise agreed.

In no event shall the CAISO have any responsibility or liability to the Interconnection Customer for liquidated damages pursuant to the provisions of this Article 5.3.

- 5.4 Power System Stabilizers.** The Interconnection Customer shall procure, install, maintain and operate Power System Stabilizers in accordance with the guidelines and procedures established by the Applicable Reliability Council and in accordance with the provisions of Section 4.6.5.1 of the CAISO Tariff. The CAISO reserves the right to establish reasonable minimum acceptable settings for any installed Power System Stabilizers, subject to the design and operating limitations of the Large Generating Facility. If the Large Generating Facility's Power System Stabilizers are removed from service or not capable of automatic operation, the Interconnection Customer shall immediately notify the CAISO and the Participating TO and restore the Power System Stabilizers to operation as soon as possible and in accordance with the Reliability Management System Agreement in Appendix G. The CAISO shall have the right to order the reduction in output or disconnection of the Large Generating Facility if the reliability of the CAISO Controlled Grid would be adversely affected as a result of improperly tuned Power System Stabilizers. The requirements of this Article 5.4 shall not apply to wind generators of the induction type.
- 5.5 Equipment Procurement.** If responsibility for construction of the Participating TO's Interconnection Facilities or Network Upgrades is to be borne by the Participating TO, then the Participating TO shall commence design of the

Participating TO's Interconnection Facilities or Network Upgrades and procure necessary equipment as soon as practicable after all of the following conditions are satisfied, unless the Parties otherwise agree in writing:

- 5.5.1** The CAISO, in coordination with the applicable Participating TO(s), has completed the Interconnection Facilities Study pursuant to the Interconnection Facilities Study Agreement;
 - 5.5.2** The Participating TO has received written authorization to proceed with design and procurement from the Interconnection Customer by the date specified in Appendix B, Milestones; and
 - 5.5.3** The Interconnection Customer has provided security to the Participating TO in accordance with Article 11.5 by the dates specified in Appendix B, Milestones.
- 5.6 Construction Commencement.** The Participating TO shall commence construction of the Participating TO's Interconnection Facilities and Network Upgrades for which it is responsible as soon as practicable after the following additional conditions are satisfied:
- 5.6.1** Approval of the appropriate Governmental Authority has been obtained for any facilities requiring regulatory approval;
 - 5.6.2** Necessary real property rights and rights-of-way have been obtained, to the extent required for the construction of a discrete aspect of the Participating TO's Interconnection Facilities and Network Upgrades;
 - 5.6.3** The Participating TO has received written authorization to proceed with construction from the Interconnection Customer by the date specified in Appendix B, Milestones; and
 - 5.6.4** The Interconnection Customer has provided payment and security to the Participating TO in accordance with Article 11.5 by the dates specified in Appendix B, Milestones.
- 5.7 Work Progress.** The Parties will keep each other advised periodically as to the progress of their respective design, procurement and construction efforts. Any Party may, at any time, request a progress report from another Party. If, at any time, the Interconnection Customer determines that the completion of the Participating TO's Interconnection Facilities will not be required until after the specified In-Service Date, the Interconnection Customer will provide written notice to the Participating TO and CAISO of such later date upon which the completion of the Participating TO's Interconnection Facilities will be required.

- 5.8 Information Exchange.** As soon as reasonably practicable after the Effective Date, the Parties shall exchange information regarding the design and compatibility of the Interconnection Customer's Interconnection Facilities and Participating TO's Interconnection Facilities and compatibility of the Interconnection Facilities with the Participating TO's Transmission System, and shall work diligently and in good faith to make any necessary design changes.
- 5.9 Limited Operation.** If any of the Participating TO's Interconnection Facilities or Network Upgrades are not reasonably expected to be completed prior to the Commercial Operation Date of the Electric Generating Unit, the Participating TO and/or CAISO, as applicable, shall, upon the request and at the expense of the Interconnection Customer, perform operating studies on a timely basis to determine the extent to which the Electric Generating Unit and the Interconnection Customer's Interconnection Facilities may operate prior to the completion of the Participating TO's Interconnection Facilities or Network Upgrades consistent with Applicable Laws and Regulations, Applicable Reliability Standards, Good Utility Practice, and this LGIA. The Participating TO and CAISO shall permit Interconnection Customer to operate the Electric Generating Unit and the Interconnection Customer's Interconnection Facilities in accordance with the results of such studies.
- 5.10 Interconnection Customer's Interconnection Facilities.** The Interconnection Customer shall, at its expense, design, procure, construct, own and install the Interconnection Customer's Interconnection Facilities, as set forth in Appendix A.
- 5.10.1 Large Generating Facility and Interconnection Customer's Interconnection Facilities Specifications.** The Interconnection Customer shall submit initial specifications for the Interconnection Customer's Interconnection Facilities and Large Generating Facility, including System Protection Facilities, to the Participating TO and the CAISO at least one hundred eighty (180) Calendar Days prior to the Initial Synchronization Date; and final specifications for review and comment at least ninety (90) Calendar Days prior to the Initial Synchronization Date. The Participating TO and the CAISO shall review such specifications pursuant to this LGIA and the LGIP to ensure that the Interconnection Customer's Interconnection Facilities and Large Generating Facility are compatible with the technical specifications, operational control, safety requirements, and any other applicable requirements of the Participating TO and the CAISO and comment on such specifications within thirty (30) Calendar Days of the Interconnection Customer's submission. All specifications provided hereunder shall be deemed confidential.
- 5.10.2 Participating TO's and CAISO's Review.** The Participating TO's and the CAISO's review of the Interconnection Customer's final specifications shall not be construed as confirming, endorsing, or providing a warranty as to the design, fitness, safety, durability or reliability of the Large Generating Facility, or the Interconnection Customer's Interconnection Facilities.

Interconnection Customer shall make such changes to the Interconnection Customer's Interconnection Facilities as may reasonably be required by the Participating TO or the CAISO, in accordance with Good Utility Practice, to ensure that the Interconnection Customer's Interconnection Facilities are compatible with the technical specifications, Operational Control, and safety requirements of the Participating TO or the CAISO.

5.10.3 Interconnection Customer's Interconnection Facilities Construction.

The Interconnection Customer's Interconnection Facilities shall be designed and constructed in accordance with Good Utility Practice. Within one hundred twenty (120) Calendar Days after the Commercial Operation Date, unless the Participating TO and Interconnection Customer agree on another mutually acceptable deadline, the Interconnection Customer shall deliver to the Participating TO and CAISO "as-built" drawings, information and documents for the Interconnection Customer's Interconnection Facilities and the Electric Generating Unit(s), such as: a one-line diagram, a site plan showing the Large Generating Facility and the Interconnection Customer's Interconnection Facilities, plan and elevation drawings showing the layout of the Interconnection Customer's Interconnection Facilities, a relay functional diagram, relaying AC and DC schematic wiring diagrams and relay settings for all facilities associated with the Interconnection Customer's step-up transformers, the facilities connecting the Large Generating Facility to the step-up transformers and the Interconnection Customer's Interconnection Facilities, and the impedances (determined by factory tests) for the associated step-up transformers and the Electric Generating Units. The Interconnection Customer shall provide the Participating TO and the CAISO specifications for the excitation system, automatic voltage regulator, Large Generating Facility control and protection settings, transformer tap settings, and communications, if applicable. Any deviations from the relay settings, machine specifications, and other specifications originally submitted by the Interconnection Customer shall be assessed by the Participating TO and the CAISO pursuant to the appropriate provisions of this LGIA and the LGIP.

5.10.4 Interconnection Customer to Meet Requirements of the Participating TO's Interconnection Handbook. The Interconnection Customer shall comply with the Participating TO's Interconnection Handbook.

- 5.11 Participating TO's Interconnection Facilities Construction.** The Participating TO's Interconnection Facilities shall be designed and constructed in accordance with Good Utility Practice. Upon request, within one hundred twenty (120) Calendar Days after the Commercial Operation Date, unless the Participating TO and Interconnection Customer agree on another mutually acceptable deadline, the Participating TO shall deliver to the Interconnection Customer and the CAISO

the following “as-built” drawings, information and documents for the Participating TO's Interconnection Facilities. No as-built drawings will be provided.

The Participating TO will obtain control for operating and maintenance purposes of the Participating TO's Interconnection Facilities and Stand Alone Network Upgrades upon completion of such facilities. Pursuant to Article 5.2, the CAISO will obtain Operational Control of the Stand Alone Network Upgrades prior to the Commercial Operation Date.

- 5.12 Access Rights.** Upon reasonable notice and supervision by a Party, and subject to any required or necessary regulatory approvals, a Party (“Granting Party”) shall furnish at no cost to the other Party (“Access Party”) any rights of use, licenses, rights of way and easements with respect to lands owned or controlled by the Granting Party, its agents (if allowed under the applicable agency agreement), or any Affiliate, that are necessary to enable the Access Party to obtain ingress and egress to construct, operate, maintain, repair, test (or witness testing), inspect, replace or remove facilities and equipment to: (i) interconnect the Large Generating Facility with the Participating TO's Transmission System; (ii) operate and maintain the Large Generating Facility, the Interconnection Facilities and the Participating TO's Transmission System; and (iii) disconnect or remove the Access Party's facilities and equipment upon termination of this LGIA. In exercising such licenses, rights of way and easements, the Access Party shall not unreasonably disrupt or interfere with normal operation of the Granting Party's business and shall adhere to the safety rules and procedures established in advance, as may be changed from time to time, by the Granting Party and provided to the Access Party.
- 5.13 Lands of Other Property Owners.** If any part of the Participating TO's Interconnection Facilities and/or Network Upgrades are to be installed on property owned by persons other than the Interconnection Customer or Participating TO, the Participating TO shall at the Interconnection Customer's expense use efforts, similar in nature and extent to those that it typically undertakes on its own behalf or on behalf of its Affiliates, including use of its eminent domain authority, and to the extent consistent with state law, to procure from such persons any rights of use, licenses, rights of way and easements that are necessary to construct, operate, maintain, test, inspect, replace or remove the Participating TO's Interconnection Facilities and/or Network Upgrades upon such property.
- 5.14 Permits.** Participating TO and Interconnection Customer shall cooperate with each other in good faith in obtaining all permits, licenses and authorization that are necessary to accomplish the interconnection in compliance with Applicable Laws and Regulations. With respect to this paragraph, the Participating TO shall provide permitting assistance to the Interconnection Customer comparable to that provided to the Participating TO's own, or an Affiliate's generation.

5.15 Early Construction of Base Case Facilities. The Interconnection Customer may request the Participating TO to construct, and the Participating TO shall construct, using Reasonable Efforts to accommodate Interconnection Customer's In-Service Date, all or any portion of any Network Upgrades required for Interconnection Customer to be interconnected to the Participating TO's Transmission System which are included in the Base Case of the Interconnection Studies for the Interconnection Customer, and which also are required to be constructed for another interconnection customer, but where such construction is not scheduled to be completed in time to achieve Interconnection Customer's In-Service Date.

5.16 Suspension. The Interconnection Customer reserves the right, upon written notice to the Participating TO and the CAISO, to suspend at any time all work associated with the construction and installation of the Participating TO's Interconnection Facilities, Network Upgrades, and/or Distribution Upgrades required under this LGIA with the condition that the Participating TO's electrical system and the CAISO Controlled Grid shall be left in a safe and reliable condition in accordance with Good Utility Practice and the Participating TO's safety and reliability criteria and the CAISO's Applicable Reliability Standards. In such event, the Interconnection Customer shall be responsible for all reasonable and necessary costs which the Participating TO (i) has incurred pursuant to this LGIA prior to the suspension and (ii) incurs in suspending such work, including any costs incurred to perform such work as may be necessary to ensure the safety of persons and property and the integrity of the Participating TO's electric system during such suspension and, if applicable, any costs incurred in connection with the cancellation or suspension of material, equipment and labor contracts which the Participating TO cannot reasonably avoid; provided, however, that prior to canceling or suspending any such material, equipment or labor contract, the Participating TO shall obtain Interconnection Customer's authorization to do so.

The Participating TO shall invoice the Interconnection Customer for such costs pursuant to Article 12 and shall use due diligence to minimize its costs. In the event Interconnection Customer suspends work required under this LGIA pursuant to this Article 5.16, and has not requested the Participating TO to recommence the work or has not itself recommenced work required under this LGIA on or before the expiration of three (3) years following commencement of such suspension, this LGIA shall be deemed terminated. The three-year period shall begin on the date the suspension is requested, or the date of the written notice to the Participating TO and the CAISO, if no effective date is specified.

5.17 Taxes.

5.17.1 Interconnection Customer Payments Not Taxable. The Parties intend that all payments or property transfers made by the Interconnection Customer to the Participating TO for the installation of the Participating TO's Interconnection Facilities and the Network Upgrades shall be non-

taxable, either as contributions to capital, or as a refundable advance, in accordance with the Internal Revenue Code and any applicable state income tax laws and shall not be taxable as contributions in aid of construction or otherwise under the Internal Revenue Code and any applicable state income tax laws.

5.17.2 Representations And Covenants. In accordance with IRS Notice 2001-82 and IRS Notice 88-129, the Interconnection Customer represents and covenants that (i) ownership of the electricity generated at the Large Generating Facility will pass to another party prior to the transmission of the electricity on the CAISO Controlled Grid, (ii) for income tax purposes, the amount of any payments and the cost of any property transferred to the Participating TO for the Participating TO's Interconnection Facilities will be capitalized by the Interconnection Customer as an intangible asset and recovered using the straight-line method over a useful life of twenty (20) years, and (iii) any portion of the Participating TO's Interconnection Facilities that is a "dual-use intertie," within the meaning of IRS Notice 88-129, is reasonably expected to carry only a de minimis amount of electricity in the direction of the Large Generating Facility. For this purpose, "de minimis amount" means no more than 5 percent of the total power flows in both directions, calculated in accordance with the "5 percent test" set forth in IRS Notice 88-129. This is not intended to be an exclusive list of the relevant conditions that must be met to conform to IRS requirements for non-taxable treatment.

At the Participating TO's request, the Interconnection Customer shall provide the Participating TO with a report from an independent engineer confirming its representation in clause (iii), above. The Participating TO represents and covenants that the cost of the Participating TO's Interconnection Facilities paid for by the Interconnection Customer without the possibility of refund or credit will have no net effect on the base upon which rates are determined.

5.17.3 Indemnification for the Cost Consequence of Current Tax Liability Imposed Upon the Participating TO. Notwithstanding Article 5.17.1, the Interconnection Customer shall protect, indemnify and hold harmless the Participating TO from the cost consequences of any current tax liability imposed against the Participating TO as the result of payments or property transfers made by the Interconnection Customer to the Participating TO under this LGIA for Interconnection Facilities, as well as any interest and penalties, other than interest and penalties attributable to any delay caused by the Participating TO.

The Participating TO shall not include a gross-up for the cost consequences of any current tax liability in the amounts it charges the Interconnection Customer under this LGIA unless (i) the Participating TO

has determined, in good faith, that the payments or property transfers made by the Interconnection Customer to the Participating TO should be reported as income subject to taxation or (ii) any Governmental Authority directs the Participating TO to report payments or property as income subject to taxation; provided, however, that the Participating TO may require the Interconnection Customer to provide security for Interconnection Facilities, in a form reasonably acceptable to the Participating TO (such as a parental guarantee or a letter of credit), in an amount equal to the cost consequences of any current tax liability under this Article 5.17. The Interconnection Customer shall reimburse the Participating TO for such costs on a fully grossed-up basis, in accordance with Article 5.17.4, within thirty (30) Calendar Days of receiving written notification from the Participating TO of the amount due, including detail about how the amount was calculated.

The indemnification obligation shall terminate at the earlier of (1) the expiration of the ten year testing period and the applicable statute of limitation, as it may be extended by the Participating TO upon request of the IRS, to keep these years open for audit or adjustment, or (2) the occurrence of a subsequent taxable event and the payment of any related indemnification obligations as contemplated by this Article 5.17.

5.17.4 Tax Gross-Up Amount. The Interconnection Customer's liability for the cost consequences of any current tax liability under this Article 5.17 shall be calculated on a fully grossed-up basis. Except as may otherwise be agreed to by the parties, this means that the Interconnection Customer will pay the Participating TO, in addition to the amount paid for the Interconnection Facilities and Network Upgrades, an amount equal to (1) the current taxes imposed on the Participating TO ("Current Taxes") on the excess of (a) the gross income realized by the Participating TO as a result of payments or property transfers made by the Interconnection Customer to the Participating TO under this LGIA (without regard to any payments under this Article 5.17) (the "Gross Income Amount") over (b) the present value of future tax deductions for depreciation that will be available as a result of such payments or property transfers (the "Present Value Depreciation Amount"), plus (2) an additional amount sufficient to permit the Participating TO to receive and retain, after the payment of all Current Taxes, an amount equal to the net amount described in clause (1).

For this purpose, (i) Current Taxes shall be computed based on the Participating TO's composite federal and state tax rates at the time the payments or property transfers are received and the Participating TO will be treated as being subject to tax at the highest marginal rates in effect at that time (the "Current Tax Rate"), and (ii) the Present Value Depreciation Amount shall be computed by discounting the Participating TO's

anticipated tax depreciation deductions as a result of such payments or property transfers by the Participating TO's current weighted average cost of capital. Thus, the formula for calculating the Interconnection Customer's liability to the Participating TO pursuant to this Article 5.17.4 can be expressed as follows: $(\text{Current Tax Rate} \times (\text{Gross Income Amount} - \text{Present Value of Tax Depreciation})) / (1 - \text{Current Tax Rate})$. Interconnection Customer's estimated tax liability in the event taxes are imposed shall be stated in Appendix A, Interconnection Facilities, Network Upgrades and Distribution Upgrades.

5.17.5 Private Letter Ruling or Change or Clarification of Law. At the Interconnection Customer's request and expense, the Participating TO shall file with the IRS a request for a private letter ruling as to whether any property transferred or sums paid, or to be paid, by the Interconnection Customer to the Participating TO under this LGIA are subject to federal income taxation. The Interconnection Customer will prepare the initial draft of the request for a private letter ruling, and will certify under penalties of perjury that all facts represented in such request are true and accurate to the best of the Interconnection Customer's knowledge. The Participating TO and Interconnection Customer shall cooperate in good faith with respect to the submission of such request, provided, however, the Interconnection Customer and the Participating TO explicitly acknowledge (and nothing herein is intended to alter) Participating TO's obligation under law to certify that the facts presented in the ruling request are true, correct and complete.

The Participating TO shall keep the Interconnection Customer fully informed of the status of such request for a private letter ruling and shall execute either a privacy act waiver or a limited power of attorney, in a form acceptable to the IRS, that authorizes the Interconnection Customer to participate in all discussions with the IRS regarding such request for a private letter ruling. The Participating TO shall allow the Interconnection Customer to attend all meetings with IRS officials about the request and shall permit the Interconnection Customer to prepare the initial drafts of any follow-up letters in connection with the request.

5.17.6 Subsequent Taxable Events. If, within 10 years from the date on which the relevant Participating TO's Interconnection Facilities are placed in service, (i) the Interconnection Customer Breaches the covenants contained in Article 5.17.2, (ii) a "disqualification event" occurs within the meaning of IRS Notice 88-129, or (iii) this LGIA terminates and the Participating TO retains ownership of the Interconnection Facilities and Network Upgrades, the Interconnection Customer shall pay a tax gross-up for the cost consequences of any current tax liability imposed on the Participating TO, calculated using the methodology described in Article 5.17.4 and in accordance with IRS Notice 90-60.

5.17.7 Contests. In the event any Governmental Authority determines that the Participating TO's receipt of payments or property constitutes income that is subject to taxation, the Participating TO shall notify the Interconnection Customer, in writing, within thirty (30) Calendar Days of receiving notification of such determination by a Governmental Authority. Upon the timely written request by the Interconnection Customer and at the Interconnection Customer's sole expense, the Participating TO may appeal, protest, seek abatement of, or otherwise oppose such determination. Upon the Interconnection Customer's written request and sole expense, the Participating TO may file a claim for refund with respect to any taxes paid under this Article 5.17, whether or not it has received such a determination. The Participating TO reserve the right to make all decisions with regard to the prosecution of such appeal, protest, abatement or other contest, including the selection of counsel and compromise or settlement of the claim, but the Participating TO shall keep the Interconnection Customer informed, shall consider in good faith suggestions from the Interconnection Customer about the conduct of the contest, and shall reasonably permit the Interconnection Customer or an Interconnection Customer representative to attend contest proceedings.

The Interconnection Customer shall pay to the Participating TO on a periodic basis, as invoiced by the Participating TO, the Participating TO's documented reasonable costs of prosecuting such appeal, protest, abatement or other contest, including any costs associated with obtaining the opinion of independent tax counsel described in this Article 5.17.7. The Participating TO may abandon any contest if the Interconnection Customer fails to provide payment to the Participating TO within thirty (30) Calendar Days of receiving such invoice.

At any time during the contest, the Participating TO may agree to a settlement either with the Interconnection Customer's consent or, if such consent is refused, after obtaining written advice from independent nationally-recognized tax counsel, selected by the Participating TO, but reasonably acceptable to the Interconnection Customer, that the proposed settlement represents a reasonable settlement given the hazards of litigation. The Interconnection Customer's obligation shall be based on the amount of the settlement agreed to by the Interconnection Customer, or if a higher amount, so much of the settlement that is supported by the written advice from nationally-recognized tax counsel selected under the terms of the preceding paragraph. The settlement amount shall be calculated on a fully grossed-up basis to cover any related cost consequences of the current tax liability. The Participating TO may also settle any tax controversy without receiving the Interconnection Customer's consent or any such written advice; however, any such settlement will relieve the Interconnection Customer from any obligation to

indemnify the Participating TO for the tax at issue in the contest (unless the failure to obtain written advice is attributable to the Interconnection Customer's unreasonable refusal to the appointment of independent tax counsel).

5.17.8 Refund. In the event that (a) a private letter ruling is issued to the Participating TO which holds that any amount paid or the value of any property transferred by the Interconnection Customer to the Participating TO under the terms of this LGIA is not subject to federal income taxation, (b) any legislative change or administrative announcement, notice, ruling or other determination makes it reasonably clear to the Participating TO in good faith that any amount paid or the value of any property transferred by the Interconnection Customer to the Participating TO under the terms of this LGIA is not taxable to the Participating TO, (c) any abatement, appeal, protest, or other contest results in a determination that any payments or transfers made by the Interconnection Customer to the Participating TO are not subject to federal income tax, or (d) if the Participating TO receives a refund from any taxing authority for any overpayment of tax attributable to any payment or property transfer made by the Interconnection Customer to the Participating TO pursuant to this LGIA, the Participating TO shall promptly refund to the Interconnection Customer the following:

(i) any payment made by Interconnection Customer under this Article 5.17 for taxes that is attributable to the amount determined to be non-taxable, together with interest thereon,

(ii) interest on any amounts paid by the Interconnection Customer to the Participating TO for such taxes which the Participating TO did not submit to the taxing authority, calculated in accordance with the methodology set forth in FERC's regulations at 18 C.F.R. §35.19a(a)(2)(iii) from the date payment was made by the Interconnection Customer to the date the Participating TO refunds such payment to the Interconnection Customer, and

(iii) with respect to any such taxes paid by the Participating TO, any refund or credit the Participating TO receives or to which it may be entitled from any Governmental Authority, interest (or that portion thereof attributable to the payment described in clause (i), above) owed to the Participating TO for such overpayment of taxes (including any reduction in interest otherwise payable by the Participating TO to any Governmental Authority resulting from an offset or credit); provided, however, that the Participating TO will remit such amount promptly to the Interconnection Customer only after and to the extent that the Participating TO has received a tax refund, credit or offset from any Governmental Authority for any

applicable overpayment of income tax related to the Participating TO's Interconnection Facilities.

The intent of this provision is to leave the Parties, to the extent practicable, in the event that no taxes are due with respect to any payment for Interconnection Facilities and Network Upgrades hereunder, in the same position they would have been in had no such tax payments been made.

5.17.9 Taxes Other Than Income Taxes. Upon the timely request by the Interconnection Customer, and at the Interconnection Customer's sole expense, the CAISO or Participating TO may appeal, protest, seek abatement of, or otherwise contest any tax (other than federal or state income tax) asserted or assessed against the CAISO or Participating TO for which the Interconnection Customer may be required to reimburse the CAISO or Participating TO under the terms of this LGIA. The Interconnection Customer shall pay to the Participating TO on a periodic basis, as invoiced by the Participating TO, the Participating TO's documented reasonable costs of prosecuting such appeal, protest, abatement, or other contest. The Interconnection Customer, the CAISO, and the Participating TO shall cooperate in good faith with respect to any such contest. Unless the payment of such taxes is a prerequisite to an appeal or abatement or cannot be deferred, no amount shall be payable by the Interconnection Customer to the CAISO or Participating TO for such taxes until they are assessed by a final, non-appealable order by any court or agency of competent jurisdiction. In the event that a tax payment is withheld and ultimately due and payable after appeal, the Interconnection Customer will be responsible for all taxes, interest and penalties, other than penalties attributable to any delay caused by the Participating TO.

5.18 Tax Status. Each Party shall cooperate with the others to maintain the other Parties' tax status. Nothing in this LGIA is intended to adversely affect the CAISO's or any Participating TO's tax exempt status with respect to the issuance of bonds including, but not limited to, Local Furnishing Bonds.

5.19 Modification.

5.19.1 General. The Interconnection Customer or the Participating TO may undertake modifications to its facilities, subject to the provisions of this LGIA and the CAISO Tariff. If a Party plans to undertake a modification that reasonably may be expected to affect the other Parties' facilities, that Party shall provide to the other Parties sufficient information regarding such modification so that the other Parties may evaluate the potential impact of such modification prior to commencement of the work. Such information shall be deemed to be confidential hereunder and shall include information concerning the timing of such modifications and whether such

modifications are expected to interrupt the flow of electricity from the Large Generating Facility. The Party desiring to perform such work shall provide the relevant drawings, plans, and specifications to the other Parties at least ninety (90) Calendar Days in advance of the commencement of the work or such shorter period upon which the Parties may agree, which agreement shall not unreasonably be withheld, conditioned or delayed.

In the case of Large Generating Facility modifications that do not require the Interconnection Customer to submit an Interconnection Request, the CAISO or Participating TO shall provide, within thirty (30) Calendar Days (or such other time as the Parties may agree), an estimate of any additional modifications to the CAISO Controlled Grid, Participating TO's Interconnection Facilities, Network Upgrades or Distribution Upgrades necessitated by such Interconnection Customer modification and a good faith estimate of the costs thereof. The Participating TO and the CAISO shall determine if a Large Generating Facility modification is a Material Modification in accordance with the LGIP.

5.19.2 Standards. Any additions, modifications, or replacements made to a Party's facilities shall be designed, constructed and operated in accordance with this LGIA and Good Utility Practice.

5.19.3 Modification Costs. The Interconnection Customer shall not be directly assigned the costs of any additions, modifications, or replacements that the Participating TO makes to the Participating TO's Interconnection Facilities or the Participating TO's Transmission System to facilitate the interconnection of a third party to the Participating TO's Interconnection Facilities or the Participating TO's Transmission System, or to provide transmission service to a third party under the CAISO Tariff. The Interconnection Customer shall be responsible for the costs of any additions, modifications, or replacements to the Interconnection Facilities that may be necessary to maintain or upgrade such Interconnection Facilities consistent with Applicable Laws and Regulations, Applicable Reliability Standards or Good Utility Practice.

ARTICLE 6. TESTING AND INSPECTION

6.1 Pre-Commercial Operation Date Testing and Modifications. Prior to the Commercial Operation Date, the Participating TO shall test the Participating TO's Interconnection Facilities, Network Upgrades, and Distribution Upgrades and the Interconnection Customer shall test the Large Generating Facility and the Interconnection Customer's Interconnection Facilities to ensure their safe and reliable operation. Similar testing may be required after initial operation. Each Party shall make any modifications to its facilities that are found to be necessary as a result of such testing. The Interconnection Customer shall bear the cost of

all such testing and modifications. The Interconnection Customer shall not commence initial parallel operation of an Electric Generating Unit with the Participating TO's Transmission System until the Participating TO provides prior written approval, which approval shall not be unreasonably withheld, for operation of such Electric Generating Unit. The Interconnection Customer shall generate test energy at the Large Generating Facility only if it has arranged for the delivery of such test energy.

- 6.2 Post-Commercial Operation Date Testing and Modifications.** Each Party shall at its own expense perform routine inspection and testing of its facilities and equipment in accordance with Good Utility Practice as may be necessary to ensure the continued interconnection of the Large Generating Facility with the Participating TO's Transmission System in a safe and reliable manner. Each Party shall have the right, upon advance written notice, to require reasonable additional testing of the other Party's facilities, at the requesting Party's expense, as may be in accordance with Good Utility Practice.
- 6.3 Right to Observe Testing.** Each Party shall notify the other Parties at least fourteen (14) days in advance of its performance of tests of its Interconnection Facilities or Generating Facility. The other Parties have the right, at their own expense, to observe such testing.
- 6.4 Right to Inspect.** Each Party shall have the right, but shall have no obligation to: (i) observe another Party's tests and/or inspection of any of its System Protection Facilities and other protective equipment, including Power System Stabilizers; (ii) review the settings of another Party's System Protection Facilities and other protective equipment; and (iii) review another Party's maintenance records relative to the Interconnection Facilities, the System Protection Facilities and other protective equipment. A Party may exercise these rights from time to time as it deems necessary upon reasonable notice to the other Party. The exercise or non-exercise by a Party of any such rights shall not be construed as an endorsement or confirmation of any element or condition of the Interconnection Facilities or the System Protection Facilities or other protective equipment or the operation thereof, or as a warranty as to the fitness, safety, desirability, or reliability of same. Any information that a Party obtains through the exercise of any of its rights under this Article 6.4 shall be deemed to be Confidential Information and treated pursuant to Article 22 of this LGIA.

ARTICLE 7. METERING

- 7.1 General.** Each Party shall comply with the Applicable Reliability Council requirements. The Interconnection Customer and CAISO shall comply with the provisions of the CAISO Tariff regarding metering, including Section 10 of the CAISO Tariff. Unless otherwise agreed by the Participating TO and the Interconnection Customer, the Participating TO may install additional Metering

Equipment at the Point of Interconnection prior to any operation of any Electric Generating Unit and shall own, operate, test and maintain such Metering Equipment. Power flows to and from the Large Generating Facility shall be measured at or, at the CAISO's or Participating TO's option for its respective Metering Equipment, compensated to, the Point of Interconnection. The CAISO shall provide metering quantities to the Interconnection Customer upon request in accordance with the CAISO Tariff by directly polling the CAISO's meter data acquisition system. The Interconnection Customer shall bear all reasonable documented costs associated with the purchase, installation, operation, testing and maintenance of the Metering Equipment.

- 7.2 Check Meters.** The Interconnection Customer, at its option and expense, may install and operate, on its premises and on its side of the Point of Interconnection, one or more check meters to check the CAISO-pollled meters or the Participating TO's meters. Such check meters shall be for check purposes only and shall not be used for the measurement of power flows for purposes of this LGIA, except in the case that no other means are available on a temporary basis at the option of the CAISO or the Participating TO. The check meters shall be subject at all reasonable times to inspection and examination by the CAISO or Participating TO or their designees. The installation, operation and maintenance thereof shall be performed entirely by the Interconnection Customer in accordance with Good Utility Practice.
- 7.3 Participating TO Retail Metering.** The Participating TO may install retail revenue quality meters and associated equipment, pursuant to the Participating TO's applicable retail tariffs.

ARTICLE 8. COMMUNICATIONS

- 8.1 Interconnection Customer Obligations.** The Interconnection Customer shall maintain satisfactory operating communications with the CAISO in accordance with the provisions of the CAISO Tariff and with the Participating TO's dispatcher or representative designated by the Participating TO. The Interconnection Customer shall provide standard voice line, dedicated voice line and facsimile communications at its Large Generating Facility control room or central dispatch facility through use of either the public telephone system, or a voice communications system that does not rely on the public telephone system. The Interconnection Customer shall also provide the dedicated data circuit(s) necessary to provide Interconnection Customer data to the CAISO and Participating TO as set forth in Appendix D, Security Arrangements Details. The data circuit(s) shall extend from the Large Generating Facility to the location(s) specified by the CAISO and Participating TO. Any required maintenance of such communications equipment shall be performed by the Interconnection Customer. Operational communications shall be activated and maintained under, but not be

limited to, the following events: system paralleling or separation, scheduled and unscheduled shutdowns, equipment clearances, and hourly and daily load data.

- 8.2 Remote Terminal Unit.** Prior to the Initial Synchronization Date of each Electric Generating Unit, a Remote Terminal Unit, or equivalent data collection and transfer equipment acceptable to the Parties, shall be installed by the Interconnection Customer, or by the Participating TO at the Interconnection Customer's expense, to gather accumulated and instantaneous data to be telemetered to the location(s) designated by the CAISO and by the Participating TO through use of a dedicated point-to-point data circuit(s) as indicated in Article 8.1.
- Telemetry to the CAISO shall be provided in accordance with the CAISO's technical standards for direct telemetry. For telemetry to the Participating TO, the communication protocol for the data circuit(s) shall be specified by the Participating TO. Instantaneous bi-directional real power and reactive power flow and any other required information must be telemetered directly to the location(s) specified by the Participating TO.

Each Party will promptly advise the other Parties if it detects or otherwise learns of any metering, telemetry or communications equipment errors or malfunctions that require the attention and/or correction by another Party. The Party owning such equipment shall correct such error or malfunction as soon as reasonably feasible.

- 8.3 No Annexation.** Any and all equipment placed on the premises of a Party shall be and remain the property of the Party providing such equipment regardless of the mode and manner of annexation or attachment to real property, unless otherwise mutually agreed by the Parties.

ARTICLE 9. OPERATIONS

- 9.1 General.** Each Party shall comply with the Applicable Reliability Council requirements, and the Interconnection Customer shall execute the Reliability Management System Agreement of the Applicable Reliability Council attached hereto as Appendix G. Each Party shall provide to the other Party all information that may reasonably be required by the other Party to comply with Applicable Laws and Regulations and Applicable Reliability Standards.
- 9.2 Balancing Authority Area Notification.** At least three months before Initial Synchronization Date, the Interconnection Customer shall notify the CAISO and Participating TO in writing of the Balancing Authority Area in which the Large Generating Facility intends to be located. If the Interconnection Customer intends to locate the Large Generating Facility in a Balancing Authority Area other than the Balancing Authority Area within whose electrically metered boundaries the Large Generating Facility is located, and if permitted to do so by

the relevant transmission tariffs, all necessary arrangements, including but not limited to those set forth in Article 7 and Article 8 of this LGIA, and remote Balancing Authority Area generator interchange agreements, if applicable, and the appropriate measures under such agreements, shall be executed and implemented prior to the placement of the Large Generating Facility in the other Balancing Authority Area.

- 9.3 CAISO and Participating TO Obligations.** The CAISO and Participating TO shall cause the Participating TO's Transmission System to be operated and controlled in a safe and reliable manner and in accordance with this LGIA. The Participating TO at the Interconnection Customer's expense shall cause the Participating TO's Interconnection Facilities to be operated, maintained and controlled in a safe and reliable manner and in accordance with this LGIA. The CAISO and Participating TO may provide operating instructions to the Interconnection Customer consistent with this LGIA and Participating TO and CAISO operating protocols and procedures as they may change from time to time. The Participating TO and CAISO will consider changes to their operating protocols and procedures proposed by the Interconnection Customer.
- 9.4 Interconnection Customer Obligations.** The Interconnection Customer shall at its own expense operate, maintain and control the Large Generating Facility and the Interconnection Customer's Interconnection Facilities in a safe and reliable manner and in accordance with this LGIA. The Interconnection Customer shall operate the Large Generating Facility and the Interconnection Customer's Interconnection Facilities in accordance with all applicable requirements of the Balancing Authority Area of which it is part, including such requirements as set forth in Appendix C, Interconnection Details, of this LGIA. Appendix C, Interconnection Details, will be modified to reflect changes to the requirements as they may change from time to time. A Party may request that another Party provide copies of the requirements set forth in Appendix C, Interconnection Details, of this LGIA. The Interconnection Customer shall not commence Commercial Operation of an Electric Generating Unit with the Participating TO's Transmission System until the Participating TO provides prior written approval, which approval shall not be unreasonably withheld, for operation of such Electric Generating Unit.
- 9.5 Start-Up and Synchronization.** Consistent with the Parties' mutually acceptable procedures, the Interconnection Customer is responsible for the proper synchronization of each Electric Generating Unit to the CAISO Controlled Grid.
- 9.6 Reactive Power.**
- 9.6.1 Power Factor Design Criteria.** The Interconnection Customer shall design the Large Generating Facility to maintain a composite power delivery at continuous rated power output at the terminals of the Electric

Generating Unit at a power factor within the range of 0.95 leading to 0.90 lagging, unless the CAISO has established different requirements that apply to all generators in the Balancing Authority Area on a comparable basis. Power factor design criteria for wind generators are provided in Appendix H of this LGIA.

9.6.2 Voltage Schedules. Once the Interconnection Customer has synchronized an Electric Generating Unit with the CAISO Controlled Grid, the CAISO or Participating TO shall require the Interconnection Customer to maintain a voltage schedule by operating the Electric Generating Unit to produce or absorb reactive power within the design limitations of the Electric Generating Unit set forth in Article 9.6.1 (Power Factor Design Criteria). CAISO's voltage schedules shall treat all sources of reactive power in the Balancing Authority Area in an equitable and not unduly discriminatory manner. The Participating TO shall exercise Reasonable Efforts to provide the Interconnection Customer with such schedules at least one (1) day in advance, and the CAISO or Participating TO may make changes to such schedules as necessary to maintain the reliability of the CAISO Controlled Grid or the Participating TO's electric system. The Interconnection Customer shall operate the Electric Generating Unit to maintain the specified output voltage or power factor within the design limitations of the Electric Generating Unit set forth in Article 9.6.1 (Power Factor Design Criteria), and as may be required by the CAISO to operate the Electric Generating Unit at a specific voltage schedule within the design limitations set forth in Article 9.6.1. If the Interconnection Customer is unable to maintain the specified voltage or power factor, it shall promptly notify the CAISO and the Participating TO.

9.6.2.1 Governors and Regulators. Whenever an Electric Generating Unit is operated in parallel with the CAISO Controlled Grid and the speed governors (if installed on the Electric Generating Unit pursuant to Good Utility Practice) and voltage regulators are capable of operation, the Interconnection Customer shall operate the Electric Generating Unit with its speed governors and voltage regulators in automatic operation. If the Electric Generating Unit's speed governors and voltage regulators are not capable of such automatic operation, the Interconnection Customer shall immediately notify the CAISO and the Participating TO and ensure that the Electric Generating Unit operates as specified in Article 9.6.2 through manual operation and that such Electric Generating Unit's reactive power production or absorption (measured in MVARs) are within the design capability of the Electric Generating Unit(s) and steady state stability limits. The Interconnection Customer shall restore the speed governors and voltage regulators to automatic operation as soon as possible and in accordance with the Reliability Management System Agreement

in Appendix G. If the Large Generating Facility's speed governors and voltage regulators are improperly tuned or malfunctioning, the CAISO shall have the right to order the reduction in output or disconnection of the Large Generating Facility if the reliability of the CAISO Controlled Grid would be adversely affected. The Interconnection Customer shall not cause its Large Generating Facility to disconnect automatically or instantaneously from the CAISO Controlled Grid or trip any Electric Generating Unit comprising the Large Generating Facility for an under or over frequency condition unless the abnormal frequency condition persists for a time period beyond the limits set forth in ANSI/IEEE Standard C37.106, or such other standard as applied to other generators in the Balancing Authority Area on a comparable basis.

9.6.3 Payment for Reactive Power. CAISO is required to pay the Interconnection Customer for reactive power that Interconnection Customer provides or absorbs from an Electric Generating Unit when the CAISO requests the Interconnection Customer to operate its Electric Generating Unit outside the range specified in Article 9.6.1, provided that if the CAISO pays other generators for reactive power service within the specified range, it must also pay the Interconnection Customer. Payments shall be pursuant to Article 11.6 or such other agreement to which the CAISO and Interconnection Customer have otherwise agreed.

9.7 Outages and Interruptions.

9.7.1 Outages.

9.7.1.1 Outage Authority and Coordination. Each Party may in accordance with Good Utility Practice in coordination with the other Parties remove from service any of its respective Interconnection Facilities or Network Upgrades that may impact another Party's facilities as necessary to perform maintenance or testing or to install or replace equipment. Absent an Emergency Condition, the Party scheduling a removal of such facility(ies) from service will use Reasonable Efforts to schedule such removal on a date and time mutually acceptable to all Parties. In all circumstances any Party planning to remove such facility(ies) from service shall use Reasonable Efforts to minimize the effect on the other Parties of such removal.

9.7.1.2 Outage Schedules. The CAISO shall post scheduled outages of CAISO Controlled Grid facilities in accordance with the provisions of the CAISO Tariff. The Interconnection Customer shall submit its planned maintenance schedules for the Large Generating Facility to the CAISO in accordance with the CAISO

Tariff. The Interconnection Customer shall update its planned maintenance schedules in accordance with the CAISO Tariff. The CAISO may request the Interconnection Customer to reschedule its maintenance as necessary to maintain the reliability of the CAISO Controlled Grid in accordance with the CAISO Tariff. Such planned maintenance schedules and updates and changes to such schedules shall be provided by the Interconnection Customer to the Participating TO concurrently with their submittal to the CAISO. The CAISO shall compensate the Interconnection Customer for any additional direct costs that the Interconnection Customer incurs as a result of having to reschedule maintenance in accordance with the CAISO Tariff. The Interconnection Customer will not be eligible to receive compensation, if during the twelve (12) months prior to the date of the scheduled maintenance, the Interconnection Customer had modified its schedule of maintenance activities.

9.7.1.3 Outage Restoration. If an outage on a Party's Interconnection Facilities or Network Upgrades adversely affects another Party's operations or facilities, the Party that owns or controls the facility that is out of service shall use Reasonable Efforts to promptly restore such facility(ies) to a normal operating condition consistent with the nature of the outage. The Party that owns or controls the facility that is out of service shall provide the other Parties, to the extent such information is known, information on the nature of the Emergency Condition, if the outage is caused by an Emergency Condition, an estimated time of restoration, and any corrective actions required. Initial verbal notice shall be followed up as soon as practicable with written notice explaining the nature of the outage, if requested by a Party, which may be provided by e-mail or facsimile.

9.7.2 Interruption of Service. If required by Good Utility Practice to do so, the CAISO or the Participating TO may require the Interconnection Customer to interrupt or reduce deliveries of electricity if such delivery of electricity could adversely affect the CAISO's or the Participating TO's ability to perform such activities as are necessary to safely and reliably operate and maintain the Participating TO's electric system or the CAISO Controlled Grid. The following provisions shall apply to any interruption or reduction permitted under this Article 9.7.2:

9.7.2.1 The interruption or reduction shall continue only for so long as reasonably necessary under Good Utility Practice;

9.7.2.2 Any such interruption or reduction shall be made on an equitable, non-discriminatory basis with respect to all generating

facilities directly connected to the CAISO Controlled Grid, subject to any conditions specified in this LGIA;

9.7.2.3 When the interruption or reduction must be made under circumstances which do not allow for advance notice, the CAISO or Participating TO, as applicable, shall notify the Interconnection Customer by telephone as soon as practicable of the reasons for the curtailment, interruption, or reduction, and, if known, its expected duration. Telephone notification shall be followed by written notification, if requested by the Interconnection Customer, as soon as practicable;

9.7.2.4 Except during the existence of an Emergency Condition, the CAISO or Participating TO shall notify the Interconnection Customer in advance regarding the timing of such interruption or reduction and further notify the Interconnection Customer of the expected duration. The CAISO or Participating TO shall coordinate with the Interconnection Customer using Good Utility Practice to schedule the interruption or reduction during periods of least impact to the Interconnection Customer, the CAISO, and the Participating TO;

9.7.2.5 The Parties shall cooperate and coordinate with each other to the extent necessary in order to restore the Large Generating Facility, Interconnection Facilities, the Participating TO's Transmission System, and the CAISO Controlled Grid to their normal operating state, consistent with system conditions and Good Utility Practice.

9.7.3 Under-Frequency and Over Frequency Conditions. The CAISO Controlled Grid is designed to automatically activate a load-shed program as required by the Applicable Reliability Council in the event of an under-frequency system disturbance. The Interconnection Customer shall implement under-frequency and over-frequency protection set points for the Large Generating Facility as required by the Applicable Reliability Council to ensure "ride through" capability. Large Generating Facility response to frequency deviations of pre-determined magnitudes, both under-frequency and over-frequency deviations, shall be studied and coordinated with the Participating TO and CAISO in accordance with Good Utility Practice. The term "ride through" as used herein shall mean the ability of a Generating Facility to stay connected to and synchronized with the CAISO Controlled Grid during system disturbances within a range of under-frequency and over-frequency conditions, in accordance with Good Utility Practice.

9.7.4 System Protection and Other Control Requirements.

- 9.7.4.1 System Protection Facilities.** The Interconnection Customer shall, at its expense, install, operate and maintain System Protection Facilities as a part of the Large Generating Facility or the Interconnection Customer's Interconnection Facilities. The Participating TO shall install at the Interconnection Customer's expense any System Protection Facilities that may be required on the Participating TO's Interconnection Facilities or the Participating TO's Transmission System as a result of the interconnection of the Large Generating Facility and the Interconnection Customer's Interconnection Facilities.
- 9.7.4.2** The Participating TO's and Interconnection Customer's protection facilities shall be designed and coordinated with other systems in accordance with Applicable Reliability Council criteria and Good Utility Practice.
- 9.7.4.3** The Participating TO and Interconnection Customer shall each be responsible for protection of its facilities consistent with Good Utility Practice.
- 9.7.4.4** The Participating TO's and Interconnection Customer's protective relay design shall incorporate the necessary test switches to perform the tests required in Article 6. The required test switches will be placed such that they allow operation of lockout relays while preventing breaker failure schemes from operating and causing unnecessary breaker operations and/or the tripping of the Interconnection Customer's Electric Generating Units.
- 9.7.4.5** The Participating TO and Interconnection Customer will test, operate and maintain System Protection Facilities in accordance with Good Utility Practice and, if applicable, the requirements of the Participating TO's Interconnection Handbook.
- 9.7.4.6** Prior to the in-service date, and again prior to the Commercial Operation Date, the Participating TO and Interconnection Customer or their agents shall perform a complete calibration test and functional trip test of the System Protection Facilities. At intervals suggested by Good Utility Practice, the standards and procedures of the Participating TO, including, if applicable, the requirements of the Participating TO's Interconnection Handbook, and following any apparent malfunction of the System Protection Facilities, each Party shall perform both calibration and functional trip tests of its System Protection

Facilities. These tests do not require the tripping of any in-service generation unit. These tests do, however, require that all protective relays and lockout contacts be activated.

- 9.7.5 Requirements for Protection.** In compliance with Good Utility Practice and, if applicable, the requirements of the Participating TO's Interconnection Handbook, the Interconnection Customer shall provide, install, own, and maintain relays, circuit breakers and all other devices necessary to remove any fault contribution of the Large Generating Facility to any short circuit occurring on the Participating TO's Transmission System not otherwise isolated by the Participating TO's equipment, such that the removal of the fault contribution shall be coordinated with the protective requirements of the Participating TO's Transmission System. Such protective equipment shall include, without limitation, a disconnecting device with fault current-interrupting capability located between the Large Generating Facility and the Participating TO's Transmission System at a site selected upon mutual agreement (not to be unreasonably withheld, conditioned or delayed) of the Parties. The Interconnection Customer shall be responsible for protection of the Large Generating Facility and the Interconnection Customer's other equipment from such conditions as negative sequence currents, over- or under-frequency, sudden load rejection, over- or under-voltage, and generator loss-of-field. The Interconnection Customer shall be solely responsible to disconnect the Large Generating Facility and the Interconnection Customer's other equipment if conditions on the CAISO Controlled Grid could adversely affect the Large Generating Facility.
- 9.7.6 Power Quality.** Neither the Participating TO's nor the Interconnection Customer's facilities shall cause excessive voltage flicker nor introduce excessive distortion to the sinusoidal voltage or current waves as defined by ANSI Standard C84.1-1989, in accordance with IEEE Standard 519, any applicable superseding electric industry standard, or any alternative Applicable Reliability Council standard. In the event of a conflict between ANSI Standard C84.1-1989, any applicable superseding electric industry standard, or any alternative Applicable Reliability Council standard, the alternative Applicable Reliability Council standard shall control.
- 9.8 Switching and Tagging Rules.** Each Party shall provide the other Parties a copy of its switching and tagging rules that are applicable to the other Parties' activities. Such switching and tagging rules shall be developed on a non-discriminatory basis. The Parties shall comply with applicable switching and tagging rules, as amended from time to time, in obtaining clearances for work or for switching operations on equipment.
- 9.9 Use of Interconnection Facilities by Third Parties.**

- 9.9.1 Purpose of Interconnection Facilities.** Except as may be required by Applicable Laws and Regulations, or as otherwise agreed to among the Parties, the Interconnection Facilities shall be constructed for the sole purpose of interconnecting the Large Generating Facility to the Participating TO's Transmission System and shall be used for no other purpose.
- 9.9.2 Third Party Users.** If required by Applicable Laws and Regulations or if the Parties mutually agree, such agreement not to be unreasonably withheld, to allow one or more third parties to use the Participating TO's Interconnection Facilities, or any part thereof, the Interconnection Customer will be entitled to compensation for the capital expenses it incurred in connection with the Interconnection Facilities based upon the pro rata use of the Interconnection Facilities by the Participating TO, all third party users, and the Interconnection Customer, in accordance with Applicable Laws and Regulations or upon some other mutually-agreed upon methodology. In addition, cost responsibility for ongoing costs, including operation and maintenance costs associated with the Interconnection Facilities, will be allocated between the Interconnection Customer and any third party users based upon the pro rata use of the Interconnection Facilities by the Participating TO, all third party users, and the Interconnection Customer, in accordance with Applicable Laws and Regulations or upon some other mutually agreed upon methodology. If the issue of such compensation or allocation cannot be resolved through such negotiations, it shall be submitted to FERC for resolution.
- 9.10 Disturbance Analysis Data Exchange.** The Parties will cooperate with one another in the analysis of disturbances to either the Large Generating Facility or the CAISO Controlled Grid by gathering and providing access to any information relating to any disturbance, including information from oscillography, protective relay targets, breaker operations and sequence of events records, and any disturbance information required by Good Utility Practice.

ARTICLE 10. MAINTENANCE

- 10.1 Participating TO Obligations.** The Participating TO shall maintain the Participating TO's Transmission System and the Participating TO's Interconnection Facilities in a safe and reliable manner and in accordance with this LGIA.
- 10.2 Interconnection Customer Obligations.** The Interconnection Customer shall maintain the Large Generating Facility and the Interconnection Customer's Interconnection Facilities in a safe and reliable manner and in accordance with this LGIA.

- 10.3 Coordination.** The Parties shall confer regularly to coordinate the planning, scheduling and performance of preventive and corrective maintenance on the Large Generating Facility and the Interconnection Facilities.
- 10.4 Secondary Systems.** The Participating TO and Interconnection Customer shall cooperate with the other Parties in the inspection, maintenance, and testing of control or power circuits that operate below 600 volts, AC or DC, including, but not limited to, any hardware, control or protective devices, cables, conductors, electric raceways, secondary equipment panels, transducers, batteries, chargers, and voltage and current transformers that directly affect the operation of a Party's facilities and equipment which may reasonably be expected to impact the other Parties. Each Party shall provide advance notice to the other Parties before undertaking any work on such circuits, especially on electrical circuits involving circuit breaker trip and close contacts, current transformers, or potential transformers.
- 10.5 Operating and Maintenance Expenses.** Subject to the provisions herein addressing the use of facilities by others, and except for operations and maintenance expenses associated with modifications made for providing interconnection or transmission service to a third party and such third party pays for such expenses, the Interconnection Customer shall be responsible for all reasonable expenses including overheads, associated with: (1) owning, operating, maintaining, repairing, and replacing the Interconnection Customer's Interconnection Facilities; and (2) operation, maintenance, repair and replacement of the Participating TO's Interconnection Facilities.

ARTICLE 11. PERFORMANCE OBLIGATION

- 11.1 Interconnection Customer's Interconnection Facilities.** The Interconnection Customer shall design, procure, construct, install, own and/or control the Interconnection Customer's Interconnection Facilities described in Appendix A at its sole expense.
- 11.2 Participating TO's Interconnection Facilities.** The Participating TO shall design, procure, construct, install, own and/or control the Participating TO's Interconnection Facilities described in Appendix A at the sole expense of the Interconnection Customer. Unless the Participating TO elects to fund the capital for the Participating TO's Interconnection Facilities, they shall be solely funded by the Interconnection Customer.
- 11.3 Network Upgrades and Distribution Upgrades.** The Participating TO shall design, procure, construct, install, and own the Network Upgrades and Distribution Upgrades described in Appendix A. The Interconnection Customer shall be responsible for all costs related to Distribution Upgrades. Unless the Participating TO elects to fund the capital for the Distribution Upgrades and Network Upgrades, they shall be solely funded by the Interconnection Customer.

11.4 Transmission Credits. No later than thirty (30) days prior to the Commercial Operation Date, the Interconnection Customer may make a one-time election by written notice to the CAISO and the Participating TO to receive Congestion Revenue Rights as defined in and as available under the CAISO Tariff at the time of the election in accordance with the CAISO Tariff, in lieu of a refund of the cost of Network Upgrades in accordance with Article 11.4.1.

11.4.1 Repayment of Amounts Advanced for Network Upgrades. Upon the Commercial Operation Date, the Interconnection Customer shall be entitled to a repayment, equal to the total amount paid to the Participating TO for the cost of Network Upgrades. Such amount shall include any tax gross-up or other tax-related payments associated with Network Upgrades not refunded to the Interconnection Customer pursuant to Article 5.17.8 or otherwise, and shall be paid to the Interconnection Customer by the Participating TO on a dollar-for-dollar basis either through (1) direct payments made on a levelized basis over the five-year period commencing on the Commercial Operation Date; or (2) any alternative payment schedule that is mutually agreeable to the Interconnection Customer and Participating TO, provided that such amount is paid within five (5) years from the Commercial Operation Date. Notwithstanding the foregoing, if this LGIA terminates within five (5) years from the Commercial Operation Date, the Participating TO's obligation to pay refunds to the Interconnection Customer shall cease as of the date of termination. Any repayment shall include interest calculated in accordance with the methodology set forth in FERC's regulations at 18 C.F.R. §35.19a(a)(2)(iii) from the date of any payment for Network Upgrades through the date on which the Interconnection Customer receives a repayment of such payment. Interest shall continue to accrue on the repayment obligation so long as this LGIA is in effect. The Interconnection Customer may assign such repayment rights to any person.

If the Large Generating Facility fails to achieve commercial operation, but it or another Generating Facility is later constructed and makes use of the Network Upgrades, the Participating TO shall at that time reimburse Interconnection Customer for the amounts advanced for the Network Upgrades. Before any such reimbursement can occur, the Interconnection Customer, or the entity that ultimately constructs the Generating Facility, if different, is responsible for identifying the entity to which reimbursement must be made.

11.4.2 Special Provisions for Affected Systems. The Interconnection Customer shall enter into an agreement with the owner of the Affected System and/or other affected owners of portions of the CAISO Controlled Grid, as applicable, in accordance with the LGIP. Such agreement shall

specify the terms governing payments to be made by the Interconnection Customer to the owner of the Affected System and/or other affected owners of portions of the CAISO Controlled Grid as well as the repayment by the owner of the Affected System and/or other affected owners of portions of the CAISO Controlled Grid. In no event shall the Participating TO be responsible for the repayment for any facilities that are not part of the Participating TO's Transmission System.

11.4.3 Notwithstanding any other provision of this LGIA, nothing herein shall be construed as relinquishing or foreclosing any rights, including but not limited to firm transmission rights, capacity rights, Congestion Revenue Rights, or transmission credits, that the Interconnection Customer shall be entitled to, now or in the future under any other agreement or tariff as a result of, or otherwise associated with, the transmission capacity, if any, created by the Network Upgrades, including the right to obtain cash reimbursements or transmission credits for transmission service that is not associated with the Large Generating Facility.

11.5 Provision of Security. At least thirty (30) Calendar Days prior to the commencement of the procurement, installation, or construction of a discrete portion of a Participating TO's Interconnection Facilities, Network Upgrades, or Distribution Upgrades, the Interconnection Customer shall provide the Participating TO, at the Interconnection Customer's option, a guarantee, a surety bond, letter of credit or other form of security that is reasonably acceptable to the Participating TO and is consistent with the Uniform Commercial Code of the jurisdiction identified in Article 14.2.1. Such security for payment shall be in an amount sufficient to cover the costs for constructing, procuring and installing the applicable portion of the Participating TO's Interconnection Facilities, Network Upgrades, or Distribution Upgrades. Such security shall be reduced on a dollar-for-dollar basis for payments made to the Participating TO for these purposes.

In addition:

11.5.1 The guarantee must be made by an entity that meets the creditworthiness requirements of the Participating TO, and contain terms and conditions that guarantee payment of any amount that may be due from the Interconnection Customer, up to an agreed-to maximum amount.

11.5.2 The letter of credit must be issued by a financial institution reasonably acceptable to the Participating TO and must specify a reasonable expiration date.

11.5.3 The surety bond must be issued by an insurer reasonably acceptable to the Participating TO and must specify a reasonable expiration date.

11.6 Interconnection Customer Compensation. If the CAISO requests or directs the Interconnection Customer to provide a service pursuant to Articles 9.6.3 (Payment for Reactive Power) or 13.5.1 of this LGIA, the CAISO shall compensate the Interconnection Customer in accordance with the CAISO Tariff.

11.6.1 Interconnection Customer Compensation for Actions During Emergency Condition. The CAISO shall compensate the Interconnection Customer in accordance with the CAISO Tariff for its provision of real and reactive power and other Emergency Condition services that the Interconnection Customer provides to support the CAISO Controlled Grid during an Emergency Condition in accordance with Article 11.6.

ARTICLE 12. INVOICE

12.1 General. The Participating TO shall submit to the Interconnection Customer, on a monthly basis, invoices of amounts due pursuant to this LGIA for the preceding month. Each invoice shall state the month to which the invoice applies and fully describe the services and equipment provided. The Parties may discharge mutual debts and payment obligations due and owing to each other on the same date through netting, in which case all amounts a Party owes to the other Party under this LGIA, including interest payments or credits, shall be netted so that only the net amount remaining due shall be paid by the owing Party. Notwithstanding the foregoing, any invoices between the CAISO and another Party shall be submitted and paid in accordance with the CAISO Tariff.

12.2 Final Invoice. As soon as reasonably practicable, but within twelve months after completion of the construction of the Participating TO's Interconnection Facilities, Network Upgrades, and Distribution Upgrades, the Participating TO shall provide an invoice of the final cost of the construction of the Participating TO's Interconnection Facilities, Network Upgrades, and Distribution Upgrades, and shall set forth such costs in sufficient detail to enable the Interconnection Customer to compare the actual costs with the estimates and to ascertain deviations, if any, from the cost estimates. The Participating TO shall refund to the Interconnection Customer any amount by which the actual payment by the Interconnection Customer for estimated costs exceeds the actual costs of construction within thirty (30) Calendar Days of the issuance of such final construction invoice; or, in the event the actual costs of construction exceed the Interconnection Customer's actual payment for estimated costs, then the Interconnection Customer shall pay to the Participating TO any amount by which the actual costs of construction exceed the actual payment by the Interconnection Customer for estimated costs within thirty (30) Calendar Days of the issuance of such final construction invoice.

- 12.3 Payment.** Invoices shall be rendered to the Interconnection Customer at the address specified in Appendix F. The Interconnection Customer shall pay, or Participating TO shall refund, the amounts due within thirty (30) Calendar Days of the Interconnection Customer's receipt of the invoice. All payments shall be made in immediately available funds payable to the Interconnection Customer or Participating TO, or by wire transfer to a bank named and account designated by the invoicing Interconnection Customer or Participating TO. Payment of invoices by any Party will not constitute a waiver of any rights or claims any Party may have under this LGIA.
- 12.4 Disputes.** In the event of a billing dispute between the Interconnection Customer and the Participating TO, the Participating TO and the CAISO shall continue to provide Interconnection Service under this LGIA as long as the Interconnection Customer: (i) continues to make all payments not in dispute; and (ii) pays to the Participating TO or into an independent escrow account the portion of the invoice in dispute, pending resolution of such dispute. If the Interconnection Customer fails to meet these two requirements for continuation of service, then the Participating TO may provide notice to the Interconnection Customer of a Default pursuant to Article 17. Within thirty (30) Calendar Days after the resolution of the dispute, the Party that owes money to the other Party shall pay the amount due with interest calculated in accordance with the methodology set forth in FERC's Regulations at 18 C.F.R. § 35.19a(a)(2)(iii). Notwithstanding the foregoing, any billing dispute between the CAISO and another Party shall be resolved in accordance with the provisions of Article 27 of this LGIA.

ARTICLE 13. EMERGENCIES

- 13.1 [Reserved]**
- 13.2 Obligations.** Each Party shall comply with the Emergency Condition procedures of the CAISO, NERC, the Applicable Reliability Council, Applicable Laws and Regulations, and any emergency procedures set forth in this LGIA.
- 13.3 Notice.** The Participating TO or the CAISO shall notify the Interconnection Customer promptly when it becomes aware of an Emergency Condition that affects the Participating TO's Interconnection Facilities or Distribution System or the CAISO Controlled Grid, respectively, that may reasonably be expected to affect the Interconnection Customer's operation of the Large Generating Facility or the Interconnection Customer's Interconnection Facilities. The Interconnection Customer shall notify the Participating TO and the CAISO promptly when it becomes aware of an Emergency Condition that affects the Large Generating Facility or the Interconnection Customer's Interconnection Facilities that may reasonably be expected to affect the CAISO Controlled Grid or the Participating TO's Interconnection Facilities. To the extent information is known, the

notification shall describe the Emergency Condition, the extent of the damage or deficiency, the expected effect on the operation of the Interconnection Customer's or Participating TO's facilities and operations, its anticipated duration and the corrective action taken and/or to be taken. The initial notice shall be followed as soon as practicable with written notice, if requested by a Party, which may be provided by electronic mail or facsimile, or in the case of the CAISO may be publicly posted on the CAISO's internet web site.

13.4 Immediate Action. Unless, in the Interconnection Customer's reasonable judgment, immediate action is required, the Interconnection Customer shall obtain the consent of the CAISO and the Participating TO, such consent to not be unreasonably withheld, prior to performing any manual switching operations at the Large Generating Facility or the Interconnection Customer's Interconnection Facilities in response to an Emergency Condition declared by the Participating TO or CAISO or in response to any other emergency condition.

13.5 CAISO and Participating TO Authority.

13.5.1 General. The CAISO and Participating TO may take whatever actions or inactions, including issuance of dispatch instructions, with regard to the CAISO Controlled Grid or the Participating TO's Interconnection Facilities or Distribution System they deem necessary during an Emergency Condition in order to (i) preserve public health and safety, (ii) preserve the reliability of the CAISO Controlled Grid or the Participating TO's Interconnection Facilities or Distribution System, and (iii) limit or prevent damage, and (iv) expedite restoration of service.

The Participating TO and the CAISO shall use Reasonable Efforts to minimize the effect of such actions or inactions on the Large Generating Facility or the Interconnection Customer's Interconnection Facilities. The Participating TO or the CAISO may, on the basis of technical considerations, require the Large Generating Facility to mitigate an Emergency Condition by taking actions necessary and limited in scope to remedy the Emergency Condition, including, but not limited to, directing the Interconnection Customer to shut-down, start-up, increase or decrease the real or reactive power output of the Large Generating Facility; implementing a reduction or disconnection pursuant to Article 13.5.2; directing the Interconnection Customer to assist with black start (if available) or restoration efforts; or altering the outage schedules of the Large Generating Facility and the Interconnection Customer's Interconnection Facilities. Interconnection Customer shall comply with all of the CAISO's and Participating TO's operating instructions concerning Large Generating Facility real power and reactive power output within the manufacturer's design limitations of the Large Generating Facility's equipment that is in service and physically available for operation at the time, in compliance with Applicable Laws and Regulations.

13.5.2 Reduction and Disconnection. The Participating TO or the CAISO may reduce Interconnection Service or disconnect the Large Generating Facility or the Interconnection Customer's Interconnection Facilities when such reduction or disconnection is necessary under Good Utility Practice due to Emergency Conditions. These rights are separate and distinct from any right of curtailment of the CAISO pursuant to the CAISO Tariff. When the CAISO or Participating TO can schedule the reduction or disconnection in advance, the CAISO or Participating TO shall notify the Interconnection Customer of the reasons, timing and expected duration of the reduction or disconnection. The CAISO or Participating TO shall coordinate with the Interconnection Customer using Good Utility Practice to schedule the reduction or disconnection during periods of least impact to the Interconnection Customer and the CAISO and Participating TO. Any reduction or disconnection shall continue only for so long as reasonably necessary under Good Utility Practice. The Parties shall cooperate with each other to restore the Large Generating Facility, the Interconnection Facilities, and the CAISO Controlled Grid to their normal operating state as soon as practicable consistent with Good Utility Practice.

13.6 Interconnection Customer Authority. Consistent with Good Utility Practice, this LGIA, and the CAISO Tariff, the Interconnection Customer may take actions or inactions with regard to the Large Generating Facility or the Interconnection Customer's Interconnection Facilities during an Emergency Condition in order to (i) preserve public health and safety, (ii) preserve the reliability of the Large Generating Facility or the Interconnection Customer's Interconnection Facilities, (iii) limit or prevent damage, and (iv) expedite restoration of service. Interconnection Customer shall use Reasonable Efforts to minimize the effect of such actions or inactions on the CAISO Controlled Grid and the Participating TO's Interconnection Facilities. The CAISO and Participating TO shall use Reasonable Efforts to assist Interconnection Customer in such actions.

13.7 Limited Liability. Except as otherwise provided in Article 11.6.1 of this LGIA, no Party shall be liable to any other Party for any action it takes in responding to an Emergency Condition so long as such action is made in good faith and is consistent with Good Utility Practice.

ARTICLE 14. REGULATORY REQUIREMENTS AND GOVERNING LAW

14.1 Regulatory Requirements. Each Party's obligations under this LGIA shall be subject to its receipt of any required approval or certificate from one or more Governmental Authorities in the form and substance satisfactory to the applying Party, or the Party making any required filings with, or providing notice to, such Governmental Authorities, and the expiration of any time period associated

therewith. Each Party shall in good faith seek and use its Reasonable Efforts to obtain such other approvals. Nothing in this LGIA shall require the Interconnection Customer to take any action that could result in its inability to obtain, or its loss of, status or exemption under the Federal Power Act or the Public Utility Holding Company Act of 1935, as amended, or the Public Utility Regulatory Policies Act of 1978, or the Energy Policy Act of 2005.

14.2 Governing Law.

14.2.1 The validity, interpretation and performance of this LGIA and each of its provisions shall be governed by the laws of the state where the Point of Interconnection is located, without regard to its conflicts of law principles.

14.2.2 This LGIA is subject to all Applicable Laws and Regulations.

14.2.3 Each Party expressly reserves the right to seek changes in, appeal, or otherwise contest any laws, orders, rules, or regulations of a Governmental Authority.

ARTICLE 15. NOTICES

15.1 General. Unless otherwise provided in this LGIA, any notice, demand or request required or permitted to be given by a Party to another and any instrument required or permitted to be tendered or delivered by a Party in writing to another shall be effective when delivered and may be so given, tendered or delivered, by recognized national courier, or by depositing the same with the United States Postal Service with postage prepaid, for delivery by certified or registered mail, addressed to the Party, or personally delivered to the Party, at the address set out in Appendix F, Addresses for Delivery of Notices and Billings.

A Party must update the information in Appendix F as information changes. A Party may change the notice information in this LGIA by giving five (5) Business Days written notice prior to the effective date of the change. Such changes shall not constitute an amendment to this LGIA.

15.2 Billings and Payments. Billings and payments shall be sent to the addresses set out in Appendix F.

15.3 Alternative Forms of Notice. Any notice or request required or permitted to be given by a Party to another and not required by this LGIA to be given in writing may be so given by telephone, facsimile or e-mail to the telephone numbers and e-mail addresses set out in Appendix F.

15.4 Operations and Maintenance Notice. Each Party shall notify the other Parties in writing of the identity of the person(s) that it designates as the point(s) of contact with respect to the implementation of Articles 9 and 10.

ARTICLE 16. FORCE MAJEURE

16.1 Force Majeure.

16.1.1 Economic hardship is not considered a Force Majeure event.

16.1.2 No Party shall be considered to be in Default with respect to any obligation hereunder, (including obligations under Article 4), other than the obligation to pay money when due, if prevented from fulfilling such obligation by Force Majeure. A Party unable to fulfill any obligation hereunder (other than an obligation to pay money when due) by reason of Force Majeure shall give notice and the full particulars of such Force Majeure to the other Party in writing or by telephone as soon as reasonably possible after the occurrence of the cause relied upon. Telephone notices given pursuant to this Article shall be confirmed in writing as soon as reasonably possible and shall specifically state full particulars of the Force Majeure, the time and date when the Force Majeure occurred and when the Force Majeure is reasonably expected to cease. The Party affected shall exercise due diligence to remove such disability with reasonable dispatch, but shall not be required to accede or agree to any provision not satisfactory to it in order to settle and terminate a strike or other labor disturbance.

ARTICLE 17. DEFAULT

17.1 Default

17.1.1 General. No Default shall exist where such failure to discharge an obligation (other than the payment of money) is the result of Force Majeure as defined in this LGIA or the result of an act or omission of the other Party. Upon a Breach, the affected non-Breaching Party(ies) shall give written notice of such Breach to the Breaching Party. Except as provided in Article 17.1.2, the Breaching Party shall have thirty (30) Calendar Days from receipt of the Default notice within which to cure such Breach; provided however, if such Breach is not capable of cure within thirty (30) Calendar Days, the Breaching Party shall commence such cure within thirty (30) Calendar Days after notice and continuously and diligently complete such cure within ninety (90) Calendar Days from receipt of the Default notice; and, if cured within such time, the Breach specified in such notice shall cease to exist.

17.1.2 Right to Terminate. If a Breach is not cured as provided in this Article, or if a Breach is not capable of being cured within the period provided for herein, the affected non-Breaching Party(ies) shall have the right to declare a Default and terminate this LGIA by written notice at any time until cure occurs, and be relieved of any further obligation hereunder and, whether or not such Party(ies) terminates this LGIA, to recover from the Breaching Party all amounts due hereunder, plus all other damages and remedies to which it is entitled at law or in equity. The provisions of this Article will survive termination of this LGIA.

ARTICLE 18. INDEMNITY, CONSEQUENTIAL DAMAGES AND INSURANCE

18.1 Indemnity. Each Party shall at all times indemnify, defend, and hold the other Parties harmless from, any and all Losses arising out of or resulting from another Party's action or inactions of its obligations under this LGIA on behalf of the indemnifying Party, except in cases of gross negligence or intentional wrongdoing by the Indemnified Party.

18.1.1 Indemnified Party. If an Indemnified Party is entitled to indemnification under this Article 18 as a result of a claim by a third party, and the Indemnifying Party fails, after notice and reasonable opportunity to proceed under Article 18.1, to assume the defense of such claim, such Indemnified Party may at the expense of the Indemnifying Party contest, settle or consent to the entry of any judgment with respect to, or pay in full, such claim.

18.1.2 Indemnifying Party. If an Indemnifying Party is obligated to indemnify and hold any Indemnified Party harmless under this Article 18, the amount owing to the Indemnified Party shall be the amount of such Indemnified Party's actual Loss, net of any insurance or other recovery.

18.1.3 Indemnity Procedures. Promptly after receipt by an Indemnified Party of any claim or notice of the commencement of any action or administrative or legal proceeding or investigation as to which the indemnity provided for in Article 18.1 may apply, the Indemnified Party shall notify the Indemnifying Party of such fact. Any failure of or delay in such notification shall not affect a Party's indemnification obligation unless such failure or delay is materially prejudicial to the indemnifying Party.

The Indemnifying Party shall have the right to assume the defense thereof with counsel designated by such Indemnifying Party and reasonably satisfactory to the Indemnified Party. If the defendants in any such action include one or more Indemnified Parties and the Indemnifying Party and if the Indemnified Party reasonably concludes that there may

be legal defenses available to it and/or other Indemnified Parties which are different from or additional to those available to the Indemnifying Party, the Indemnified Party shall have the right to select separate counsel to assert such legal defenses and to otherwise participate in the defense of such action on its own behalf. In such instances, the Indemnifying Party shall only be required to pay the fees and expenses of one additional attorney to represent an Indemnified Party or Indemnified Parties having such differing or additional legal defenses.

The Indemnified Party shall be entitled, at its expense, to participate in any such action, suit or proceeding, the defense of which has been assumed by the Indemnifying Party. Notwithstanding the foregoing, the Indemnifying Party (i) shall not be entitled to assume and control the defense of any such action, suit or proceedings if and to the extent that, in the opinion of the Indemnified Party and its counsel, such action, suit or proceeding involves the potential imposition of criminal liability on the Indemnified Party, or there exists a conflict or adversity of interest between the Indemnified Party and the Indemnifying Party, in such event the Indemnifying Party shall pay the reasonable expenses of the Indemnified Party, and (ii) shall not settle or consent to the entry of any judgment in any action, suit or proceeding without the consent of the Indemnified Party, which shall not be unreasonably withheld, conditioned or delayed.

18.2 Consequential Damages. Other than the liquidated damages heretofore described in Article 5.3, in no event shall any Party be liable under any provision of this LGIA for any losses, damages, costs or expenses for any special, indirect, incidental, consequential, or punitive damages, including but not limited to loss of profit or revenue, loss of the use of equipment, cost of capital, cost of temporary equipment or services, whether based in whole or in part in contract, in tort, including negligence, strict liability, or any other theory of liability; provided, however, that damages for which a Party may be liable to another Party under another agreement will not be considered to be special, indirect, incidental, or consequential damages hereunder.

18.3 Insurance. Each Party shall, at its own expense, maintain in force throughout the period of this LGIA, and until released by the other Parties, the following minimum insurance coverages, with insurers rated no less than A- (with a minimum size rating of VII) by Bests' Insurance Guide and Key Ratings and authorized to do business in the state where the Point of Interconnection is located, except in the case of the CAISO, the State of California:

18.3.1 Employer's Liability and Workers' Compensation Insurance providing statutory benefits in accordance with the laws and regulations of the state in which the Point of Interconnection is located, except in the case of the CAISO, the State of California.

- 18.3.2** Commercial General Liability Insurance including premises and operations, personal injury, broad form property damage, broad form blanket contractual liability coverage (including coverage for the contractual indemnification) products and completed operations coverage, coverage for explosion, collapse and underground hazards, independent contractors coverage, coverage for pollution to the extent normally available and punitive damages to the extent normally available and a cross liability endorsement, with minimum limits of One Million Dollars (\$1,000,000) per occurrence/One Million Dollars (\$1,000,000) aggregate combined single limit for personal injury, bodily injury, including death and property damage.
- 18.3.3** Business Automobile Liability Insurance for coverage of owned and non-owned and hired vehicles, trailers or semi-trailers designed for travel on public roads, with a minimum, combined single limit of One Million Dollars (\$1,000,000) per occurrence for bodily injury, including death, and property damage.
- 18.3.4** Excess Public Liability Insurance over and above the Employer's Liability Commercial General Liability and Business Automobile Liability Insurance coverage, with a minimum combined single limit of Twenty Million Dollars (\$20,000,000) per occurrence/Twenty Million Dollars (\$20,000,000) aggregate.
- 18.3.5** The Commercial General Liability Insurance, Business Automobile Insurance and Excess Public Liability Insurance policies shall name the other Parties, their parents, associated and Affiliate companies and their respective directors, officers, agents, servants and employees ("Other Party Group") as additional insured. All policies shall contain provisions whereby the insurers waive all rights of subrogation in accordance with the provisions of this LGIA against the Other Party Group and provide thirty (30) Calendar Days advance written notice to the Other Party Group prior to anniversary date of cancellation or any material change in coverage or condition.
- 18.3.6** The Commercial General Liability Insurance, Business Automobile Liability Insurance and Excess Public Liability Insurance policies shall contain provisions that specify that the policies are primary and shall apply to such extent without consideration for other policies separately carried and shall state that each insured is provided coverage as though a separate policy had been issued to each, except the insurer's liability shall not be increased beyond the amount for which the insurer would have been liable had only one insured been covered. Each Party shall be responsible for its respective deductibles or retentions.

- 18.3.7** The Commercial General Liability Insurance, Business Automobile Liability Insurance and Excess Public Liability Insurance policies, if written on a Claims First Made Basis, shall be maintained in full force and effect for two (2) years after termination of this LGIA, which coverage may be in the form of tail coverage or extended reporting period coverage if agreed by the Parties.
- 18.3.8** The requirements contained herein as to the types and limits of all insurance to be maintained by the Parties are not intended to and shall not in any manner, limit or qualify the liabilities and obligations assumed by the Parties under this LGIA.
- 18.3.9** Within ten (10) Calendar Days following execution of this LGIA, and as soon as practicable after the end of each fiscal year or at the renewal of the insurance policy and in any event within ninety (90) Calendar Days thereafter, each Party shall provide certification of all insurance required in this LGIA, executed by each insurer or by an authorized representative of each insurer.
- 18.3.10** Notwithstanding the foregoing, each Party may self-insure to meet the minimum insurance requirements of Articles 18.3.2 through 18.3.8 to the extent it maintains a self-insurance program; provided that, such Party's senior unsecured debt or issuer rating is BBB-, or better, as rated by Standard & Poor's and that its self-insurance program meets the minimum insurance requirements of Articles 18.3.2 through 18.3.8. For any period of time that a Party's senior unsecured debt rating and issuer rating are both unrated by Standard & Poor's or are both rated at less than BBB- by Standard & Poor's, such Party shall comply with the insurance requirements applicable to it under Articles 18.3.2 through 18.3.9. In the event that a Party is permitted to self-insure pursuant to this Article 18.3.10, it shall notify the other Parties that it meets the requirements to self-insure and that its self-insurance program meets the minimum insurance requirements in a manner consistent with that specified in Article 18.3.9.
- 18.3.11** The Parties agree to report to each other in writing as soon as practical all accidents or occurrences resulting in injuries to any person, including death, and any property damage arising out of this LGIA.

ARTICLE 19. ASSIGNMENT

- 19.1 Assignment.** This LGIA may be assigned by a Party only with the written consent of the other Parties; provided that a Party may assign this LGIA without the consent of the other Parties to any Affiliate of the assigning Party with an equal or greater credit rating and with the legal authority and operational ability to

satisfy the obligations of the assigning Party under this LGIA; and provided further that the Interconnection Customer shall have the right to assign this LGIA, without the consent of the CAISO or Participating TO, for collateral security purposes to aid in providing financing for the Large Generating Facility, provided that the Interconnection Customer will promptly notify the CAISO and Participating TO of any such assignment. Any financing arrangement entered into by the Interconnection Customer pursuant to this Article will provide that prior to or upon the exercise of the secured party's, trustee's or mortgagee's assignment rights pursuant to said arrangement, the secured creditor, the trustee or mortgagee will notify the CAISO and Participating TO of the date and particulars of any such exercise of assignment right(s), including providing the CAISO and Participating TO with proof that it meets the requirements of Articles 11.5 and 18.3. Any attempted assignment that violates this Article is void and ineffective. Any assignment under this LGIA shall not relieve a Party of its obligations, nor shall a Party's obligations be enlarged, in whole or in part, by reason thereof. Where required, consent to assignment will not be unreasonably withheld, conditioned or delayed.

ARTICLE 20. SEVERABILITY

- 20.1 Severability.** If any provision in this LGIA is finally determined to be invalid, void or unenforceable by any court or other Governmental Authority having jurisdiction, such determination shall not invalidate, void or make unenforceable any other provision, agreement or covenant of this LGIA; provided that if the Interconnection Customer (or any third party, but only if such third party is not acting at the direction of the Participating TO or CAISO) seeks and obtains such a final determination with respect to any provision of the Alternate Option (Article 5.1.2), or the Negotiated Option (Article 5.1.4), then none of the provisions of Article 5.1.2 or 5.1.4 shall thereafter have any force or effect and the Parties' rights and obligations shall be governed solely by the Standard Option (Article 5.1.1).

ARTICLE 21. COMPARABILITY

- 21.1 Comparability.** The Parties will comply with all applicable comparability and code of conduct laws, rules and regulations, as amended from time to time.

ARTICLE 22. CONFIDENTIALITY

22.1 Confidentiality. Confidential Information shall include, without limitation, all information relating to a Party's technology, research and development, business affairs, and pricing, and any information supplied by any of the Parties to the other Parties prior to the execution of this LGIA.

Information is Confidential Information only if it is clearly designated or marked in writing as confidential on the face of the document, or, if the information is conveyed orally or by inspection, if the Party providing the information orally informs the Parties receiving the information that the information is confidential.

If requested by any Party, the other Parties shall provide in writing, the basis for asserting that the information referred to in this Article 22 warrants confidential treatment, and the requesting Party may disclose such writing to the appropriate Governmental Authority. Each Party shall be responsible for the costs associated with affording confidential treatment to its information.

22.1.1 Term. During the term of this LGIA, and for a period of three (3) years after the expiration or termination of this LGIA, except as otherwise provided in this Article 22, each Party shall hold in confidence and shall not disclose to any person Confidential Information.

22.1.2 Scope. Confidential Information shall not include information that the receiving Party can demonstrate: (1) is generally available to the public other than as a result of a disclosure by the receiving Party; (2) was in the lawful possession of the receiving Party on a non-confidential basis before receiving it from the disclosing Party; (3) was supplied to the receiving Party without restriction by a third party, who, to the knowledge of the receiving Party after due inquiry, was under no obligation to the disclosing Party to keep such information confidential; (4) was independently developed by the receiving Party without reference to Confidential Information of the disclosing Party; (5) is, or becomes, publicly known, through no wrongful act or omission of the receiving Party or Breach of this LGIA; or (6) is required, in accordance with Article 22.1.7 of this LGIA, Order of Disclosure, to be disclosed by any Governmental Authority or is otherwise required to be disclosed by law or subpoena, or is necessary in any legal proceeding establishing rights and obligations under this LGIA. Information designated as Confidential Information will no longer be deemed confidential if the Party that designated the information as confidential notifies the other Parties that it no longer is confidential.

22.1.3 Release of Confidential Information. No Party shall release or disclose Confidential Information to any other person, except to its employees, consultants, Affiliates (limited by the Standards of Conduct requirements

set forth in Part 358 of FERC's Regulations, 18 C.F.R. 358), subcontractors, or to parties who may be or considering providing financing to or equity participation with the Interconnection Customer, or to potential purchasers or assignees of the Interconnection Customer, on a need-to-know basis in connection with this LGIA, unless such person has first been advised of the confidentiality provisions of this Article 22 and has agreed to comply with such provisions. Notwithstanding the foregoing, a Party providing Confidential Information to any person shall remain primarily responsible for any release of Confidential Information in contravention of this Article 22.

22.1.4 Rights. Each Party retains all rights, title, and interest in the Confidential Information that each Party discloses to the other Parties. The disclosure by each Party to the other Parties of Confidential Information shall not be deemed a waiver by a Party or any other person or entity of the right to protect the Confidential Information from public disclosure.

22.1.5 No Warranties. The mere fact that a Party has provided Confidential Information does not constitute a warranty or representation as to its accuracy or completeness. In addition, by supplying Confidential Information, no Party obligates itself to provide any particular information or Confidential Information to the other Parties nor to enter into any further agreements or proceed with any other relationship or joint venture.

22.1.6 Standard of Care. Each Party shall use at least the same standard of care to protect Confidential Information it receives as it uses to protect its own Confidential Information from unauthorized disclosure, publication or dissemination. Each Party may use Confidential Information solely to fulfill its obligations to the other Parties under this LGIA or its regulatory requirements.

22.1.7 Order of Disclosure. If a court or a Government Authority or entity with the right, power, and apparent authority to do so requests or requires any Party, by subpoena, oral deposition, interrogatories, requests for production of documents, administrative order, or otherwise, to disclose Confidential Information, that Party shall provide the other Parties with prompt notice of such request(s) or requirement(s) so that the other Parties may seek an appropriate protective order or waive compliance with the terms of this LGIA. Notwithstanding the absence of a protective order or waiver, the Party may disclose such Confidential Information which, in the opinion of its counsel, the Party is legally compelled to disclose. Each Party will use Reasonable Efforts to obtain reliable assurance that confidential treatment will be accorded any Confidential Information so furnished.

22.1.8 Termination of Agreement. Upon termination of this LGIA for any reason, each Party shall, within ten (10) Calendar Days of receipt of a written request from another Party, use Reasonable Efforts to destroy, erase, or delete (with such destruction, erasure, and deletion certified in writing to the other Party) or return to the other Party, without retaining copies thereof, any and all written or electronic Confidential Information received from the other Party.

22.1.9 Remedies. The Parties agree that monetary damages would be inadequate to compensate a Party for another Party's Breach of its obligations under this Article 22. Each Party accordingly agrees that the other Parties shall be entitled to equitable relief, by way of injunction or otherwise, if the first Party Breaches or threatens to Breach its obligations under this Article 22, which equitable relief shall be granted without bond or proof of damages, and the receiving Party shall not plead in defense that there would be an adequate remedy at law. Such remedy shall not be deemed an exclusive remedy for the Breach of this Article 22, but shall be in addition to all other remedies available at law or in equity. The Parties further acknowledge and agree that the covenants contained herein are necessary for the protection of legitimate business interests and are reasonable in scope. No Party, however, shall be liable for indirect, incidental, or consequential or punitive damages of any nature or kind resulting from or arising in connection with this Article 22.

22.1.10 Disclosure to FERC, its Staff, or a State. Notwithstanding anything in this Article 22 to the contrary, and pursuant to 18 C.F.R. section 1b.20, if FERC or its staff, during the course of an investigation or otherwise, requests information from one of the Parties that is otherwise required to be maintained in confidence pursuant to this LGIA, the Party shall provide the requested information to FERC or its staff, within the time provided for in the request for information. In providing the information to FERC or its staff, the Party must, consistent with 18 C.F.R. section 388.112, request that the information be treated as confidential and non-public by FERC and its staff and that the information be withheld from public disclosure. Parties are prohibited from notifying the other Parties to this LGIA prior to the release of the Confidential Information to FERC or its staff. The Party shall notify the other Parties to the LGIA when it is notified by FERC or its staff that a request to release Confidential Information has been received by FERC, at which time any of the Parties may respond before such information would be made public, pursuant to 18 C.F.R. Section 388.112. Requests from a state regulatory body conducting a confidential investigation shall be treated in a similar manner if consistent with the applicable state rules and regulations.

22.1.11 Subject to the exception in Article 22.1.10, Confidential Information shall not be disclosed by the other Parties to any person not employed or

retained by the other Parties, except to the extent disclosure is (i) required by law; (ii) reasonably deemed by the disclosing Party to be required to be disclosed in connection with a dispute between or among the Parties, or the defense of litigation or dispute; (iii) otherwise permitted by consent of the other Parties, such consent not to be unreasonably withheld; or (iv) necessary to fulfill its obligations under this LGIA or as a transmission service provider or a Balancing Authority including disclosing the Confidential Information to an RTO or ISO or to a regional or national reliability organization. The Party asserting confidentiality shall notify the other Parties in writing of the information it claims is confidential. Prior to any disclosures of another Party's Confidential Information under this subparagraph, or if any third party or Governmental Authority makes any request or demand for any of the information described in this subparagraph, the disclosing Party agrees to promptly notify the other Party in writing and agrees to assert confidentiality and cooperate with the other Party in seeking to protect the Confidential Information from public disclosure by confidentiality agreement, protective order or other reasonable measures.

ARTICLE 23. ENVIRONMENTAL RELEASES

- 23.1** Each Party shall notify the other Parties, first orally and then in writing, of the release of any Hazardous Substances, any asbestos or lead abatement activities, or any type of remediation activities related to the Large Generating Facility or the Interconnection Facilities, each of which may reasonably be expected to affect the other Parties. The notifying Party shall: (i) provide the notice as soon as practicable, provided such Party makes a good faith effort to provide the notice no later than twenty-four hours after such Party becomes aware of the occurrence; and (ii) promptly furnish to the other Parties copies of any publicly available reports filed with any Governmental Authorities addressing such events.

ARTICLE 24. INFORMATION REQUIREMENTS

- 24.1 Information Acquisition.** The Participating TO and the Interconnection Customer shall submit specific information regarding the electrical characteristics of their respective facilities to each other as described below and in accordance with Applicable Reliability Standards.
- 24.2 Information Submission by Participating TO.** The initial information submission by the Participating TO shall occur no later than one hundred eighty (180) Calendar Days prior to Trial Operation and shall include the Participating TO's Transmission System information necessary to allow the Interconnection Customer to select equipment and meet any system protection and stability

requirements, unless otherwise agreed to by the Participating TO and the Interconnection Customer. On a monthly basis the Participating TO shall provide the Interconnection Customer and the CAISO a status report on the construction and installation of the Participating TO's Interconnection Facilities and Network Upgrades, including, but not limited to, the following information: (1) progress to date; (2) a description of the activities since the last report; (3) a description of the action items for the next period; and (4) the delivery status of equipment ordered.

24.3 Updated Information Submission by Interconnection Customer. The updated information submission by the Interconnection Customer, including manufacturer information, shall occur no later than one hundred eighty (180) Calendar Days prior to the Trial Operation. The Interconnection Customer shall submit a completed copy of the Electric Generating Unit data requirements contained in Appendix 1 to the LGIP. It shall also include any additional information provided to the Participating TO and the CAISO for the Interconnection Studies. Information in this submission shall be the most current Electric Generating Unit design or expected performance data. Information submitted for stability models shall be compatible with the Participating TO and CAISO standard models. If there is no compatible model, the Interconnection Customer will work with a consultant mutually agreed to by the Parties to develop and supply a standard model and associated information.

If the Interconnection Customer's data is materially different from what was originally provided to the Participating TO and the CAISO for the Interconnection Studies, then the Participating TO and the CAISO will conduct appropriate studies pursuant to the LGIP to determine the impact on the Participating TO's Transmission System and affected portions of the CAISO Controlled Grid based on the actual data submitted pursuant to this Article 24.3. The Interconnection Customer shall not begin Trial Operation until such studies are completed and all other requirements of this LGIA are satisfied.

24.4 Information Supplementation. Prior to the Trial Operation date, the Parties shall supplement their information submissions described above in this Article 24 with any and all "as-built" Electric Generating Unit information or "as-tested" performance information that differs from the initial submissions or, alternatively, written confirmation that no such differences exist. The Interconnection Customer shall conduct tests on the Electric Generating Unit as required by Good Utility Practice such as an open circuit "step voltage" test on the Electric Generating Unit to verify proper operation of the Electric Generating Unit's automatic voltage regulator.

Unless otherwise agreed, the test conditions shall include: (1) Electric Generating Unit at synchronous speed; (2) automatic voltage regulator on and in voltage control mode; and (3) a five percent (5 percent) change in Electric Generating Unit terminal voltage initiated by a change in the voltage regulators reference

voltage. The Interconnection Customer shall provide validated test recordings showing the responses of Electric Generating Unit terminal and field voltages. In the event that direct recordings of these voltages is impractical, recordings of other voltages or currents that mirror the response of the Electric Generating Unit's terminal or field voltage are acceptable if information necessary to translate these alternate quantities to actual Electric Generating Unit terminal or field voltages is provided. Electric Generating Unit testing shall be conducted and results provided to the Participating TO and the CAISO for each individual Electric Generating Unit in a station.

Subsequent to the Commercial Operation Date, the Interconnection Customer shall provide the Participating TO and the CAISO any information changes due to equipment replacement, repair, or adjustment. The Participating TO shall provide the Interconnection Customer any information changes due to equipment replacement, repair or adjustment in the directly connected substation or any adjacent Participating TO-owned substation that may affect the Interconnection Customer's Interconnection Facilities equipment ratings, protection or operating requirements. The Parties shall provide such information pursuant to Article 5.19.

ARTICLE 25. INFORMATION ACCESS AND AUDIT RIGHTS

- 25.1 Information Access.** Each Party (the "disclosing Party") shall make available to the other Party information that is in the possession of the disclosing Party and is necessary in order for the other Party to: (i) verify the costs incurred by the disclosing Party for which the other Party is responsible under this LGIA; and (ii) carry out its obligations and responsibilities under this LGIA. The Parties shall not use such information for purposes other than those set forth in this Article 25.1 and to enforce their rights under this LGIA. Nothing in this Article 25 shall obligate the CAISO to make available to a Party any third party information in its possession or control if making such third party information available would violate a CAISO Tariff restriction on the use or disclosure of such third party information.
- 25.2 Reporting of Non-Force Majeure Events.** Each Party (the "notifying Party") shall notify the other Parties when the notifying Party becomes aware of its inability to comply with the provisions of this LGIA for a reason other than a Force Majeure event. The Parties agree to cooperate with each other and provide necessary information regarding such inability to comply, including the date, duration, reason for the inability to comply, and corrective actions taken or planned to be taken with respect to such inability to comply. Notwithstanding the foregoing, notification, cooperation or information provided under this Article shall not entitle the Party receiving such notification to allege a cause for anticipatory breach of this LGIA.

25.3 Audit Rights. Subject to the requirements of confidentiality under Article 22 of this LGIA, the Parties' audit rights shall include audits of a Party's costs pertaining to such Party's performance or satisfaction of obligations owed to the other Party under this LGIA, calculation of invoiced amounts, the CAISO's efforts to allocate responsibility for the provision of reactive support to the CAISO Controlled Grid, the CAISO's efforts to allocate responsibility for interruption or reduction of generation on the CAISO Controlled Grid, and each such Party's actions in an Emergency Condition.

25.3.1 The Interconnection Customer and the Participating TO shall each have the right, during normal business hours, and upon prior reasonable notice to the other Party, to audit at its own expense the other Party's accounts and records pertaining to either such Party's performance or either such Party's satisfaction of obligations owed to the other Party under this LGIA. Subject to Article 25.3.2, any audit authorized by this Article shall be performed at the offices where such accounts and records are maintained and shall be limited to those portions of such accounts and records that relate to each such Party's performance and satisfaction of obligations under this LGIA. Each such Party shall keep such accounts and records for a period equivalent to the audit rights periods described in Article 25.4.

25.3.2 Notwithstanding anything to the contrary in Article 25.3, each Party's rights to audit the CAISO's accounts and records shall be as set forth in Section 22.1 of the CAISO Tariff.

25.4 Audit Rights Periods.

25.4.1 Audit Rights Period for Construction-Related Accounts and Records.

Accounts and records related to the design, engineering, procurement, and construction of Participating TO's Interconnection Facilities, Network Upgrades, and Distribution Upgrades constructed by the Participating TO shall be subject to audit for a period of twenty-four months following the Participating TO's issuance of a final invoice in accordance with Article 12.2. Accounts and records related to the design, engineering, procurement, and construction of Participating TO's Interconnection Facilities and/or Stand Alone Network Upgrades constructed by the Interconnection Customer shall be subject to audit and verification by the Participating TO and the CAISO for a period of twenty-four months following the Interconnection Customer's issuance of a final invoice in accordance with Article 5.2(8).

25.4.2 Audit Rights Period for All Other Accounts and Records. Accounts and records related to a Party's performance or satisfaction of all obligations under this LGIA other than those described in Article 25.4.1 shall be subject to audit as follows: (i) for an audit relating to cost obligations, the applicable audit rights period shall be twenty-four months

after the auditing Party's receipt of an invoice giving rise to such cost obligations; and (ii) for an audit relating to all other obligations, the applicable audit rights period shall be twenty-four months after the event for which the audit is sought; provided that each Party's rights to audit the CAISO's accounts and records shall be as set forth in Section 22.1 of the CAISO Tariff.

25.5 Audit Results. If an audit by the Interconnection Customer or the Participating TO determines that an overpayment or an underpayment has occurred with respect to the other Party, a notice of such overpayment or underpayment shall be given to the other Party together with those records from the audit which supports such determination. The Party that is owed payment shall render an invoice to the other Party and such invoice shall be paid pursuant to Article 12 hereof.

25.5.1 Notwithstanding anything to the contrary in Article 25.5, the Interconnection Customer's and Participating TO's rights to audit the CAISO's accounts and records shall be as set forth in Section 22.1 of the CAISO Tariff, and the CAISO's process for remedying an overpayment or underpayment shall be as set forth in the CAISO Tariff.

ARTICLE 26. SUBCONTRACTORS

26.1 General. Nothing in this LGIA shall prevent a Party from utilizing the services of any subcontractor as it deems appropriate to perform its obligations under this LGIA; provided, however, that each Party shall require its subcontractors to comply with all applicable terms and conditions of this LGIA in providing such services and each Party shall remain primarily liable to the other Party for the performance of such subcontractor.

26.2 Responsibility of Principal. The creation of any subcontract relationship shall not relieve the hiring Party of any of its obligations under this LGIA. The hiring Party shall be fully responsible to the other Parties for the acts or omissions of any subcontractor the hiring Party hires as if no subcontract had been made; provided, however, that in no event shall the CAISO or Participating TO be liable for the actions or inactions of the Interconnection Customer or its subcontractors with respect to obligations of the Interconnection Customer under Article 5 of this LGIA. Any applicable obligation imposed by this LGIA upon the hiring Party shall be equally binding upon, and shall be construed as having application to, any subcontractor of such Party.

26.3 No Limitation by Insurance. The obligations under this Article 26 will not be limited in any way by any limitation of subcontractor's insurance.

ARTICLE 27. DISPUTES

All disputes arising out of or in connection with this LGIA whereby relief is sought by or from the CAISO shall be settled in accordance with the provisions of Article 13 of the CAISO Tariff, except that references to the CAISO Tariff in such Article 13 of the CAISO Tariff shall be read as references to this LGIA. Disputes arising out of or in connection with this LGIA not subject to provisions of Article 13 of the CAISO Tariff shall be resolved as follows:

- 27.1 Submission.** In the event either Party has a dispute, or asserts a claim, that arises out of or in connection with this LGIA or its performance, such Party (the “disputing Party”) shall provide the other Party with written notice of the dispute or claim (“Notice of Dispute”). Such dispute or claim shall be referred to a designated senior representative of each Party for resolution on an informal basis as promptly as practicable after receipt of the Notice of Dispute by the other Party. In the event the designated representatives are unable to resolve the claim or dispute through unassisted or assisted negotiations within thirty (30) Calendar Days of the other Party’s receipt of the Notice of Dispute, such claim or dispute may, upon mutual agreement of the Parties, be submitted to arbitration and resolved in accordance with the arbitration procedures set forth below. In the event the Parties do not agree to submit such claim or dispute to arbitration, each Party may exercise whatever rights and remedies it may have in equity or at law consistent with the terms of this LGIA.
- 27.2 External Arbitration Procedures.** Any arbitration initiated under this LGIA shall be conducted before a single neutral arbitrator appointed by the Parties. If the Parties fail to agree upon a single arbitrator within ten (10) Calendar Days of the submission of the dispute to arbitration, each Party shall choose one arbitrator who shall sit on a three-member arbitration panel. The two arbitrators so chosen shall within twenty (20) Calendar Days select a third arbitrator to chair the arbitration panel. In either case, the arbitrators shall be knowledgeable in electric utility matters, including electric transmission and bulk power issues, and shall not have any current or past substantial business or financial relationships with any party to the arbitration (except prior arbitration). The arbitrator(s) shall provide each of the Parties an opportunity to be heard and, except as otherwise provided herein, shall conduct the arbitration in accordance with the Commercial Arbitration Rules of the American Arbitration Association (“Arbitration Rules”) and any applicable FERC regulations; provided, however, in the event of a conflict between the Arbitration Rules and the terms of this Article 27, the terms of this Article 27 shall prevail.
- 27.3 Arbitration Decisions.** Unless otherwise agreed by the Parties, the arbitrator(s) shall render a decision within ninety (90) Calendar Days of appointment and shall notify the Parties in writing of such decision and the reasons therefor. The arbitrator(s) shall be authorized only to interpret and apply the provisions of this LGIA and shall have no power to modify or change any provision of this

Agreement in any manner. The decision of the arbitrator(s) shall be final and binding upon the Parties, and judgment on the award may be entered in any court having jurisdiction. The decision of the arbitrator(s) may be appealed solely on the grounds that the conduct of the arbitrator(s), or the decision itself, violated the standards set forth in the Federal Arbitration Act or the Administrative Dispute Resolution Act. The final decision of the arbitrator must also be filed with FERC if it affects jurisdictional rates, terms and conditions of service, Interconnection Facilities, or Network Upgrades.

- 27.4 Costs.** Each Party shall be responsible for its own costs incurred during the arbitration process and for the following costs, if applicable: (1) the cost of the arbitrator chosen by the Party to sit on the three member panel and one half of the cost of the third arbitrator chosen; or (2) one half the cost of the single arbitrator jointly chosen by the Parties.

ARTICLE 28. REPRESENTATIONS, WARRANTIES AND COVENANTS

- 28.1 General.** Each Party makes the following representations, warranties and covenants:

- 28.1.1 Good Standing.** Such Party is duly organized, validly existing and in good standing under the laws of the state in which it is organized, formed, or incorporated, as applicable; that it is qualified to do business in the state or states in which the Large Generating Facility, Interconnection Facilities and Network Upgrades owned by such Party, as applicable, are located; and that it has the corporate power and authority to own its properties, to carry on its business as now being conducted and to enter into this LGIA and carry out the transactions contemplated hereby and perform and carry out all covenants and obligations on its part to be performed under and pursuant to this LGIA.
- 28.1.2 Authority.** Such Party has the right, power and authority to enter into this LGIA, to become a Party hereto and to perform its obligations hereunder. This LGIA is a legal, valid and binding obligation of such Party, enforceable against such Party in accordance with its terms, except as the enforceability thereof may be limited by applicable bankruptcy, insolvency, reorganization or other similar laws affecting creditors' rights generally and by general equitable principles (regardless of whether enforceability is sought in a proceeding in equity or at law).
- 28.1.3 No Conflict.** The execution, delivery and performance of this LGIA does not violate or conflict with the organizational or formation documents, or bylaws or operating agreement, of such Party, or any

judgment, license, permit, order, material agreement or instrument applicable to or binding upon such Party or any of its assets.

- 28.1.4 Consent and Approval.** Such Party has sought or obtained, or, in accordance with this LGIA will seek or obtain, each consent, approval, authorization, order, or acceptance by any Governmental Authority in connection with the execution, delivery and performance of this LGIA, and it will provide to any Governmental Authority notice of any actions under this LGIA that are required by Applicable Laws and Regulations.

ARTICLE 29. [RESERVED]

ARTICLE 30. MISCELLANEOUS

- 30.1 Binding Effect.** This LGIA and the rights and obligations hereof, shall be binding upon and shall inure to the benefit of the successors and assigns of the Parties hereto.
- 30.2 Conflicts.** In the event of a conflict between the body of this LGIA and any attachment, appendices or exhibits hereto, the terms and provisions of the body of this LGIA shall prevail and be deemed the final intent of the Parties.
- 30.3 Rules of Interpretation.** This LGIA, unless a clear contrary intention appears, shall be construed and interpreted as follows: (1) the singular number includes the plural number and vice versa; (2) reference to any person includes such person's successors and assigns but, in the case of a Party, only if such successors and assigns are permitted by this LGIA, and reference to a person in a particular capacity excludes such person in any other capacity or individually; (3) reference to any agreement (including this LGIA), document, instrument or tariff means such agreement, document, instrument, or tariff as amended or modified and in effect from time to time in accordance with the terms thereof and, if applicable, the terms hereof; (4) reference to any Applicable Laws and Regulations means such Applicable Laws and Regulations as amended, modified, codified, or reenacted, in whole or in part, and in effect from time to time, including, if applicable, rules and regulations promulgated thereunder; (5) unless expressly stated otherwise, reference to any Article, Section or Appendix means such Article of this LGIA or such Appendix to this LGIA, or such Section to the LGIP or such Appendix to the LGIP, as the case may be; (6) "hereunder", "hereof", "herein", "hereto" and words of similar import shall be deemed references to this LGIA as a whole and not to any particular Article or other provision hereof or thereof; (7) "including" (and with correlative meaning "include") means including without limiting the generality of any description preceding such term; and (8) relative to the determination of any period of time,

“from” means “from and including”, “to” means “to but excluding” and “through” means “through and including”.

30.4 Entire Agreement. This LGIA, including all Appendices and Schedules attached hereto, constitutes the entire agreement among the Parties with reference to the subject matter hereof, and supersedes all prior and contemporaneous understandings or agreements, oral or written, between or among the Parties with respect to the subject matter of this LGIA. There are no other agreements, representations, warranties, or covenants which constitute any part of the consideration for, or any condition to, any Party’s compliance with its obligations under this LGIA.

30.5 No Third Party Beneficiaries. This LGIA is not intended to and does not create rights, remedies, or benefits of any character whatsoever in favor of any persons, corporations, associations, or entities other than the Parties, and the obligations herein assumed are solely for the use and benefit of the Parties, their successors in interest and, where permitted, their assigns.

30.6 Waiver. The failure of a Party to this LGIA to insist, on any occasion, upon strict performance of any provision of this LGIA will not be considered a waiver of any obligation, right, or duty of, or imposed upon, such Party.

Any waiver at any time by either Party of its rights with respect to this LGIA shall not be deemed a continuing waiver or a waiver with respect to any other failure to comply with any other obligation, right, duty of this LGIA. Termination or Default of this LGIA for any reason by the Interconnection Customer shall not constitute a waiver of the Interconnection Customer's legal rights to obtain an interconnection from the Participating TO. Any waiver of this LGIA shall, if requested, be provided in writing.

30.7 Headings. The descriptive headings of the various Articles of this LGIA have been inserted for convenience of reference only and are of no significance in the interpretation or construction of this LGIA.

30.8 Multiple Counterparts. This LGIA may be executed in two or more counterparts, each of which is deemed an original but all constitute one and the same instrument.

30.9 Amendment. The Parties may by mutual agreement amend this LGIA by a written instrument duly executed by all of the Parties. Such amendment shall become effective and a part of this LGIA upon satisfaction of all Applicable Laws and Regulations.

30.10 Modification by the Parties. The Parties may by mutual agreement amend the Appendices to this LGIA by a written instrument duly executed by all of the

Parties. Such amendment shall become effective and a part of this LGIA upon satisfaction of all Applicable Laws and Regulations.

30.11 Reservation of Rights. The CAISO and Participating TO shall each have the right to make a unilateral filing with FERC to modify this LGIA pursuant to section 205 or any other applicable provision of the Federal Power Act and FERC's rules and regulations thereunder with respect to the following Articles of this LGIA and with respect to any rates, terms and conditions, charges, classifications of service, rule or regulation covered by these Articles:

Recitals, 1, 2.1, 2.2, 2.3, 2.4, 2.6, 3.1, 3.3, 4.1, 4.2, 4.3, 4.4, 5 preamble, 5.4, 5.7, 5.8, 5.9, 5.12, 5.13, 5.18, 5.19.1, 7.1, 7.2, 8, 9.1, 9.2, 9.3, 9.5, 9.6, 9.7, 9.8, 9.10, 10.3, 11.4, 12.1, 13, 14, 15, 16, 17, 18, 19, 20, 21, 22, 23, 24.3, 24.4, 25.1, 25.2, 25.3 (excluding subparts), 25.4.2, 26, 28, 29, 30, Appendix D, Appendix F, Appendix G, and any other Article not reserved exclusively to the Participating TO or the CAISO below.

The Participating TO shall have the exclusive right to make a unilateral filing with FERC to modify this LGIA pursuant to section 205 or any other applicable provision of the Federal Power Act and FERC's rules and regulations thereunder with respect to the following Articles of this LGIA and with respect to any rates, terms and conditions, charges, classifications of service, rule or regulation covered by these Articles:

2.5, 5.1, 5.2, 5.3, 5.5, 5.6, 5.10, 5.11, 5.14, 5.15, 5.16, 5.17, 5.19 (excluding 5.19.1), 6, 7.3, 9.4, 9.9, 10.1, 10.2, 10.4, 10.5, 11.1, 11.2, 11.3, 11.5, 12.2, 12.3, 12.4, 24.1, 24.2, 25.3.1, 25.4.1, 25.5 (excluding 25.5.1), 27 (excluding preamble), Appendix A, Appendix B, Appendix C, and Appendix E.

The CAISO shall have the exclusive right to make a unilateral filing with FERC to modify this LGIA pursuant to section 205 or any other applicable provision of the Federal Power Act and FERC's rules and regulations thereunder with respect to the following Articles of this LGIA and with respect to any rates, terms and conditions, charges, classifications of service, rule or regulation covered by these Articles:

3.2, 4.5, 11.6, 25.3.2, 25.5.1, and 27 preamble.

The Interconnection Customer, the CAISO, and the Participating TO shall have the right to make a unilateral filing with FERC to modify this LGIA pursuant to section 206 or any other applicable provision of the Federal Power Act and FERC's rules and regulations thereunder; provided that each Party shall have the right to protest any such filing by another Party and to participate fully in any proceeding before FERC in which such modifications may be considered. Nothing in this LGIA shall limit the rights of the Parties or of FERC under sections

205 or 206 of the Federal Power Act and FERC's rules and regulations thereunder, except to the extent that the Parties otherwise mutually agree as provided herein.

30.12 No Partnership. This LGIA shall not be interpreted or construed to create an association, joint venture, agency relationship, or partnership among the Parties or to impose any partnership obligation or partnership liability upon any Party. No Party shall have any right, power or authority to enter into any agreement or undertaking for, or act on behalf of, or to act as or be an agent or representative of, or to otherwise bind, another Party.

30.13 Joint and Several Obligations. Except as otherwise provided in this LGIA, the obligations of the CAISO, the Participating TO, and the Interconnection Customer are several, and are neither joint nor joint and several.

IN WITNESS WHEREOF, the Parties have executed this LGIA in multiple originals, each of which shall constitute and be an original effective agreement among the Parties.

Southern California Edison Company

By: 

Name: David L. Mead

Title: Vice President, Engineering & Technical Services

Date: 11-15-10

California Independent System Operator Corporation

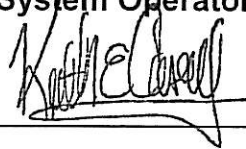
By: 

Name: _____

Title: KEITH E. CASEY, PH.D., VICE PRESIDENT
MARKET & INFRASTRUCTURE DEVELOPMENT

Date: 11.15.2010

Granite Wind, LLC

By: E. Piscitello

Name: E.S. PISCITELLO

Title: Senior VP, Granite RES Americas, Granite Wind, LLC *the sole member of*

Date: 11/12/10

Appendices to LGIA

- Appendix A Interconnection Facilities, Network Upgrades and Distribution Upgrades
- Appendix B Milestones
- Appendix C Interconnection Details
- Appendix D Security Arrangements Details
- Appendix E Commercial Operation Date
- Appendix F Addresses for Delivery of Notices and Billings
- Appendix G Reliability Management System Agreement
- Appendix H Interconnection Requirements for a Wind Generating Plant

Appendix A To LGIA

Interconnection Facilities, Network Upgrades and Distribution Upgrades

The Participating TO's Interconnection Facilities, Distribution System Upgrades and Network Upgrades described in this Appendix A to the LGIA are based on the Participating TO's preliminary engineering and design and are subject to modification to reflect the actual facilities that are constructed and installed following the Participating TO's final engineering and design, identification of field conditions, and compliance with applicable environmental and permitting requirements.

1. Interconnection Facilities:

- (a) **Interconnection Customer's Interconnection Facilities:** The Interconnection Customer shall:
- (i) Install a new 220kV Transmission Line from the Large Generating Facility identified as the Granite Mountain Wind Farm Project ("Granite Mountain Wind Farm Project") to the last Interconnection Customer-owned structure located directly outside Jasper Substation ("Last Structure). This line will be referred to as the Granite Mountain-Jasper 220kV Transmission Line.
 - (ii) Install Optical Ground Wire ("OPGW") on the Granite Mountain-Jasper 220kV Transmission Line.
 - (iii) Install other interconnection facilities which generally include the associated circuit breakers, switches, protective relaying systems, and Supervisory Control and Data Acquisition ("SCADA") equipment, to monitor and regulate the flow of electrical power. The substation will be designed and constructed in conformance with SCE and CAISO requirements along with applicable local, state, and national codes and regulations.
 - (iv) Make available adequate space and facilities necessary for the installation of the Participating TO's Remote Terminal Unit ("RTU").
 - (v) Provide a metering cabinet to house the retail meters, which should be placed at a location that allows for Participating TO 24-hour access.
 - (vi) All required CAISO approved meters and metering equipment at the Large Generating Facility and such metering equipment must be adequate to be used for the circuit feeding the Participating TO's retail meters for auxiliary load. An accuracy of 0.15% is required.
 - (vii) Install appropriate relay protection, and telecommunication single-mode fiber-optic cable for the diverse telecommunication paths. Relay protection to be specified by Participating TO so as to match relay protection used by Participating TO at Jasper Substation and at the Large Generating Facility, to protect the Granite Mountain-Jasper 220kV Transmission Line, as follows:
 1. One SEL 311L line differential relay with a digital communication channel to Jasper Substation.

2. One G.E. L90 line differential relay with a diverse path digital communication channel to Jasper Substation.
3. Two N60 relays at the Large Generating Facility (one each for SPS A and B) to trip the main generator breaker.
4. One SEL-2401 satellite synchronized clock at the Large Generating Facility.

Interconnection Customer shall install, own, operate and maintain the two diverse telecommunication paths and equipment, with the exception of the terminal equipment at both Jasper Substation and at the Large Generating Facility, which will be installed, owned, operated and maintained by the Participating TO.

- (viii) Install appropriate single-mode fiber-optic cables for the diverse telecommunication routes and also panels to terminate the telecommunication fiber-optic cables for both diverse telecommunication paths, as specified by Participating TO to match telecommunication equipment used by Participating TO at Jasper Substation and at the Large Generating Facility, to protect the Granite Mountain-Jasper 220kV Transmission Line. Interconnection Customer shall install, own, operate and maintain the two diverse telecommunication paths and fiber-optic cables and appurtenant facilities, with the exception of the terminal equipment at both Jasper Substation and at the Large Generating Facility, which will be installed, owned, operated and maintained by the Participating TO.
- (ix) Participating TO to review customer fiber-optic cable design and perform inspection to ensure compatibility with the Participating TO's terminal equipment and protection engineering requirements for diverse path communication routing. Participating TO to perform acceptance testing of fiber-optic cables and have the right to request and/or to perform correction of installation deficiencies.

(b) Participating TO's Interconnection Facilities: The Participating TO shall:

(i) Jasper Substation:

- a. Install underground vaults, risers, conduits and fiber-optic cable as necessary to terminate Granite Mountain fiber-optic cable and OPGW.
- b. Install approximately 1,000 circuit feet of new line consisting of two 500 foot spans of conductors (size to be determined) and OPGW from the last Interconnection Customer structure to the Jasper Substation 220kV switchyard using one intermediate tubular steel pole.
- c. Install the required channels to support the connection of the RTUs to be installed at the Large Generating Facility and at Jasper Substation.
- d. Install the following relays for the Granite Mountain-Jasper 220kV Transmission Line:
 - i. One GE C60 breaker management relays.
 - ii. One GE L90 line current differential relay.

(ii) Granite Mountain Generating Station:

1. Install one RTU at the Large Generating Facility to transmit generator unit gross MW and MVAR, plant auxiliary load, generator status, generator circuit breaker status, generator terminal voltage, and project net MW and MVAR. Notwithstanding that the RTU will be located on Interconnection Customer's side of the Point of Change of Ownership, Participating TO shall own, operate and maintain the RTU as part of the Participating TO's Interconnection Facilities.
2. Install all metering equipment, including voltage and current transformers, appurtenant facilities and meters for retail load on the 34.5kV side of the generator transformer. Such metering equipment will be installed inside the metering cubicle to be provided by the Interconnection Customer. Notwithstanding that the metering will be located on the Interconnection Customer's side of the Point of Change of Ownership, Participating TO shall own, operate and maintain the metering as part of the Participating TO's Interconnection Facilities.
3. Install telecommunication terminal equipment at the Large Generating Facility to support the line protection relays for the new Granite Mountain-Jasper 220kV Transmission Line and the SPS. Notwithstanding that the telecommunications terminal equipment will be located on the Interconnection Customer's side of the Point of Change of Ownership, Participating TO shall own, operate and maintain the telecommunications terminal equipment as part of the Participating TO's Interconnection Facilities.

2. Network Upgrades:

a) Stand Alone Network Upgrades: None.

b) Other Network Upgrades:

(i) Participating TO's Reliability Network Upgrades: The Participating TO shall:

1. Lugo-Pisgah No. 1 220kV Transmission Line (Temporary Interconnection):

- a. Loop the existing line in and out of Jasper Substation and form the two new Jasper-Lugo and Jasper-Pisgah 220kV Transmission Lines.

This work requires the installation of two 1/2-mile segments of single circuit line with six dead-end lattice structures and two tubular steel poles and 2-1590KCMIL ACSR conductors per phase.

This work also requires the replacement of three suspension lattice structures on adjacent 500kV T/L's to facilitate crossing of new 220kV under existing 500kV T/L's 220kV 220kV.

2. Cool Water-Jasper 220kV Transmission Line (Permanent Interconnection):

- a. Loop the proposed Cool Water-Lugo 220 kV transmission line in and out of Jasper Substation and form the two new Jasper-Lugo and Cool Water-Jasper 220kV Transmission Lines.

This work requires disconnecting the Pisgah portion of the existing Lugo-Pisgah No.1 220 kV transmission line, initially looped into Jasper Substation, and connecting the Cool Water line segment of the new Cool Water-Lugo 220 kV transmission line into the vacated position. The Participating TO estimate that the work will be done in a manner that should not result in the disconnection of Jasper Substation from the grid. The Lugo line segment is unchanged as this line segment will make use of the early interconnect facilities. A queued ahead generation project will upgrade the transmission line, except for the early interconnection facilities, back to the Lugo Substation.

3. Jasper Substation:

- a. Install the necessary equipment, including one RTU to monitor the typical bulk power elements such as MW, MVAR, and phase amps at each line and also kV at lines and buses and all circuit breaker status/control, protection relays status and alarms. The installed equipment will transmit information to the Participating TO's Grid Control Center.
- b. Install a new 220kV switchyard facility with five circuit breakers arranged in a breaker and a half configuration to initially loop in the existing Lugo-Pisgah No. 1 220kV Transmission Line and later loop in the proposed Cool Water-Lugo 220 kV Transmission Line required for a queued ahead generation project, and provide a line position to terminate the new Interconnection Customer owned Granite Mountain-Jasper 220kV Transmission Line, including:
 - i. Two 220kV operating buses covering eight positions, including necessary dead-end structures, bus supports, potential devices, disconnects, circuit breakers, adequate conductors, insulators, and circuit breakers. Six 220kV positions will be vacant for future use.
 - ii. One three breaker 220kV line position on a breaker and a half configuration to initially terminate the Jasper-Lugo and Lugo-Pisgah 220kV Transmission Lines and later terminate the Cool Water-Jasper 220kV Transmission Line.

- iii. One double breaker 220kV line position on a breaker and a half configuration to terminate the Granite Mountain-Jasper 220kV Transmission Line.
- iv. Four line dead-end structure (65 feet. high by 50 feet. wide) with a 15 foot high extension for the OPGW ground wire on one structure, to terminate the conductors from the transmission lines.
- v. Twelve GE SBD11B bus differential relays.
- vi. Four GE C60 breaker management relays.
- vii. Two GE L90 line current differential relays.
- viii. Three Schweitzer SEL-300L line differential relays.
- ix. One 32/64 digital fault recorder.
- x. One SEL-2030 communications processor.
- c. Install a 30 foot. by 20 foot. Mechanical Electrical Equipment Room (“MEER”) to house the following elements:
 - i. Batteries and battery charger.
 - ii. Light & power selector switch.
 - iii. Light & power panel.
 - iv. A.C. distribution panel.
 - v. D. C. distribution panel.
 - vi. Relays.
 - vii. Telecommunication facilities.
 - viii. SPS equipment.
 - ix. Fault recorder
 - x. Appurtenant equipment.
- d. Other station elements to be installed:
 - i. 2,030 linear feet of 8 foot. perimeter fence with double barbed wire to cover a 585 foot. by 430 foot. area.
 - ii. Two 20 foot. double door driveway gate.
 - iii. Grounding grid to cover a 591 foot. by 436 foot. area (3 feet. outside the perimeter fence).
 - iv. Approximately 2,000 linear feet of 20 foot. paved driveway.
 - v. Approximately 1,300 linear feet of control cable trench.

4. Lugo Substation:

- a. Upgrade line protection relays on the existing Lugo 220kV line position to make them compatible with the new relays to be installed at Jasper Substation when the line becomes the Jasper-Lugo 220kV transmission line by removing all existing relays and installing the following new relays:
 - i. Two GE C60 breaker management relays.
 - ii. One GE L90 line current differential relay.
 - iii. One Schweitzer SEL-311L line current differential relay.
- b. Reset and test existing SPS relays.

5. Pisgah Substation:

- a. Upgrade line protection relays on the existing Pisgah 220kV line position to make them compatible with the new relays to be installed at Jasper Substation when the line becomes the Jasper-Pisgah 220kV transmission line by removing all existing relays and installing the following new relays:
 - i. Two GE C60 breaker management relays.
 - ii. One GE L90 line current differential relay.
 - iii. One Schweitzer SEL-311L line current differential relay.
- b. Reset and test existing SPS relays.

6. Corporate Real Estate:

Perform all required functions for licensing, permitting, land acquisition and/or obtaining land easements and environmental assessments and surveys, appraisals and title work and other work as required for the new Jasper Substation and the looping of the Lugo-Pisgah 220kV transmission line into Jasper Substation, including the Jasper-Lugo and Jasper-Pisgah 220kV Transmission Line telecommunication channels.

7. Telecommunications:

- a. Install new telecommunication channels from Jasper Substation to both Lugo and Pisgah Substations and related terminal equipment to support the Jasper-Lugo and Jasper-Pisgah 220 kV Transmission Line protection relays as follows:
 - i. Approximately 29 miles of new fiber optic cable from Jasper Substation to Apple Valley Substation. The fiber optic cable will be installed using a combination of overhead and underground sections. The overhead section requires the installation of 100 new wood poles and the replacement of 600 existing wood poles.
 - ii. Approximately 19 miles of new fiber optic cable from Jasper Substation to Cottonwood Substation. The fiber optic cable will be installed using a combination of overhead and underground sections. The overhead section requires the installation of 50 new wood poles and the replacement of 400 existing wood poles.
 - iii. Use existing telecommunication channels between Apple Valley Substation, Cottonwood Substation and Lugo Substation to complete the dual routes from Jasper Substation to Lugo Substation.
 - iv. Use existing telecommunication channels between Jasper Substation and Pisgah Substation.
 - v. Install new lightwave terminal equipment and channel bank equipment at Jasper, Lugo, Pisgah, Apple Valley and Cottonwood Substations and the Large Generating Facility.

(ii) **Participating TO's Delivery Network Upgrades: None:**

3. Distribution Upgrades:

- a) Install approximately 4,000 circuit feet of new distribution circuit into to Jasper Substation to provide an alternative source of station light and power. The circuit will be formed by approximately 2,000 circuit feet of wood pole construction and 2,000 feet of underground construction. Notwithstanding Article 11.3 of the LGIA, the Interconnection Customer will not be responsible for the costs associated with these facilities.

4. Not Used:

5. Point of Change of Ownership:

- a) Granite Mountain-Jasper 220kV Transmission Line: The Point of Change of Ownership shall be the point where the conductors of the Granite Mountain-Jasper 220kV Transmission Line are attached to the Last Structure. This would be the side of the structure facing the substation. The Interconnection Customer shall own and maintain said structure, and the conductors connecting this structure with the second structure located outside Jasper Substation, including the jumper loop. The Participating TO shall own and maintain the Jasper Substation, Jasper-Pisgah 220kV Transmission Line, Jasper-Lugo 220kV Transmission Line, rights-of-way associated with the Pisgah and Lugo 220kV Transmission Lines, all circuit breakers, disconnects, relay facilities, metering within the substation, land, and the line drops in their entirety from the point they are attached to the Last Structure. The Participating TO shall own the insulators that are used to attach the Participating TO-owned conductors to the Interconnection Customer-owned structure.
- b) Telecommunication OPGW: The Point of Change of Ownership shall be the point where the OPGW of the Granite Mountain-Jasper 220kV Transmission Line are attached to the Last Structure.
- c) Telecommunication second fiber-optic cable: The Point of Change of Ownership shall be the point where the fiber-optic cable is attached to the Last Structure. The Interconnection Customer shall own and maintain said structure.
- d) The Participating TO shall own and maintain the underground vaults, risers, conduits and fiber-optic cables within the Jasper Substation and in their entirety from the point where they are attached to the Last Structure.

6. Point of Interconnection: The Participating TO's Jasper 220kV Substation.

7. One-Line Diagram of Interconnection to Jasper 220kV Substation:

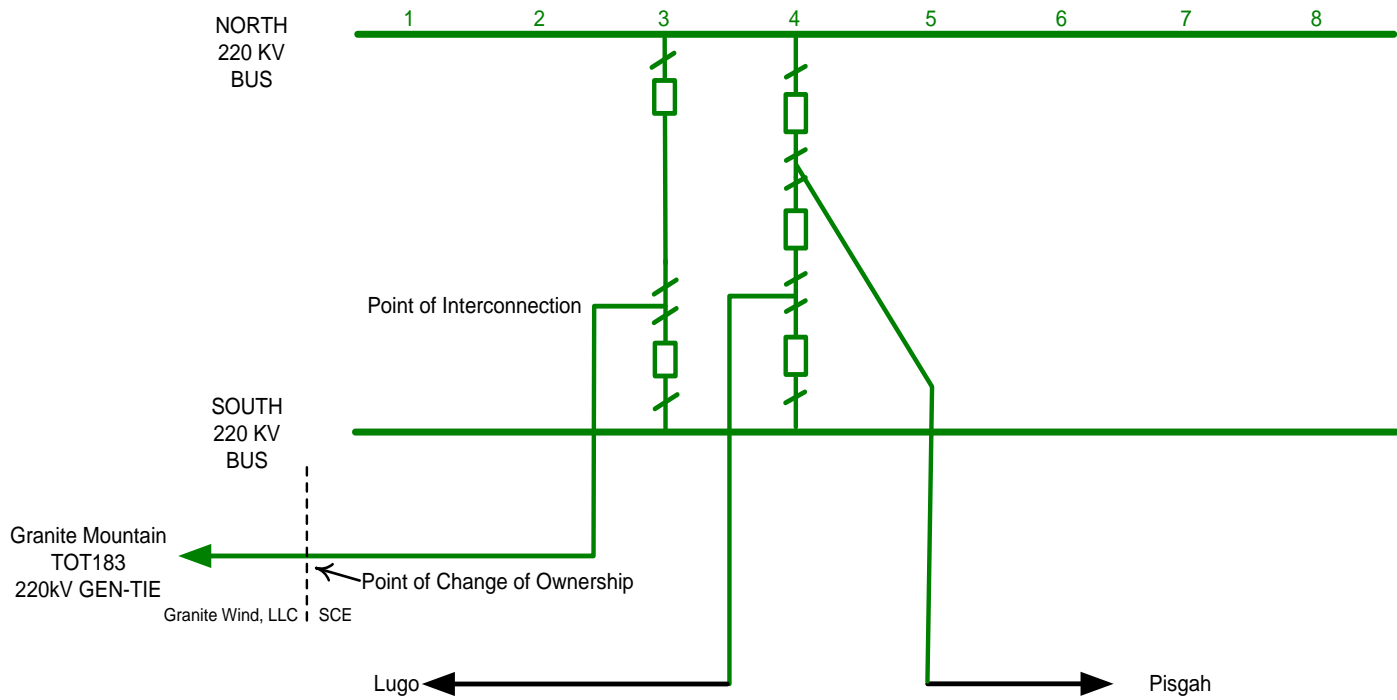

8. Additional Definitions: For the purposes of these Appendices, the following terms, when used with initial capitalization, whether in the singular or the plural, shall have the meanings specified below:

- (a) Abandoned Plant Approval: A FERC final order, not subject to rehearing or appeal, unconditionally granting the Participating TO's request for a declaratory order that the Participating TO can recover 100% of its prudently incurred costs for the Network Upgrades if such facilities are abandoned due to circumstances outside of the Participating TO's control.
- (b) Accounting Practice: Generally accepted accounting principles and practices applicable to electric utility operations.
- (c) Capital Additions: Any modifications to the Participating TO's Interconnection Facilities in accordance with Article 5.19 of the LGIA. Such modifications may be any Units of Property which are added to the Participating TO's Interconnection Facilities; the enlargement, modification or betterment of any Units of Property constituting a part of the Participating TO's Interconnection Facilities; or the replacement of any Units of Property constituting a part of the Participating TO's Interconnection Facilities, irrespective of whether such replacement constitutes an enlargement, modification or betterment of that which it replaces; the costs of which additions, enlargements, modifications, betterments or replacements in accordance with Accounting Practice would be capitalized and have not previously been included in the Interconnection Facilities Cost. If Capital Additions are required in order to benefit the Participating TO, or because of damage caused by negligence or willful misconduct of the Participating TO, then the Interconnection Customer will not bear cost responsibility for such Capital Additions, and no adjustment will be made to the Interconnection Facilities Cost, and no Capital Additions Cost or One-Time Cost will be charged to the Interconnection Customer for such Capital Additions.
- (d) CPUC: The California Public Utilities Commission, or its regulatory successor.
- (e) Credit Support: Parent guarantee, letter of credit, surety bond, or other security meeting the requirements of Article 11.5 of the LGIA.
- (f) Customer-Financed Monthly Rate: The rate most recently adopted by the CPUC for application to the Participating TO's retail electric customers for added facilities, which does not compensate the Participating TO for replacement of added facilities. The currently effective Customer-Financed Monthly Rate is as provided in Section 15 of this Appendix A.
- (g) Delivery Network Upgrades Cost: All costs, excluding One-Time Cost, determined by the Participating TO to be associated with the design, engineering, procurement, construction and installation of the Participating TO's

Delivery Network Upgrades. The Delivery Network Upgrades Cost is provided in Section 14 of this Appendix A.

- (h) Delivery Network Upgrades Payment: The sum of the Delivery Network Upgrades Cost and associated One-Time Cost. The Delivery Network Upgrades Payment is provided in Section 16 of this Appendix A.
- (i) Interconnection Facilities Charge: The monthly charge to the Interconnection Customer to recover the revenue requirements for the Participating TO's Interconnection Facilities, calculated as the product of the Customer-Financed Monthly Rate and the Interconnection Facilities Cost. The Interconnection Facilities Charge is provided in Section 15 of this Appendix A.
- (j) Interconnection Facilities Completion Date: The date upon which the construction of the Participating TO's Interconnection Facilities is complete and such facilities are successfully tested and ready for service.
- (k) Interconnection Facilities Cost: All costs, excluding One-Time Cost, determined by the Participating TO to be associated with the design, engineering, procurement, construction and installation of the Participating TO's Interconnection Facilities. The Interconnection Facilities Cost is provided in Section 14 of this Appendix A.
- (l) Interconnection Facilities Payment: The sum of the Interconnection Facilities Cost and associated One-Time Cost. The Interconnection Facilities Payment is provided in Section 16 of this Appendix A.
- (m) ITCC: The ITCC is equal to the estimated tax liability described in Article 5.17.4 of the LGIA, and is the Income Tax Component of Contribution specified in the Preliminary Statement, Part M of the Participating TO's tariff on file with the CPUC, applicable to the Interconnection Facilities Cost. An estimate of the ITCC applicable to the Interconnection Facilities Cost is described in Section 10 of this Appendix A and is shown in Section 14 of this Appendix A.
- (n) Letter Agreement: The letter agreement executed by the Participating TO and the Interconnection Customer on December 21, 2008 for work associated with land studies and environmental analysis for the Participating TO's Jasper Substation, Lugo-Pisgah 220kV Transmission Line and associated telecommunication facilities.
- (o) One-Time Cost: All costs determined by the Participating TO to be associated with the installation of the Participating TO's Interconnection Facilities, Delivery Network Upgrades, Reliability Network Upgrades or Capital Additions which are not capitalized.

- (p) Reliability Network Upgrades Cost: All costs, excluding One-Time Cost, determined by the Participating TO to be associated with the design, engineering, procurement, construction and installation of the Participating TO's Reliability Network Upgrades. The Reliability Network Upgrades Cost is provided in Section 14 of this Appendix A.
- (q) Reliability Network Upgrades Payment: The sum of the Reliability Network Upgrades Cost and associated One-Time Cost. The Reliability Network Upgrades Payment is provided in Section 16 of this Appendix A.
- (r) Removal Cost: The actual cost the Participating TO incurs for the removal of the Participating TO's Interconnection Facilities, which is calculated as the amount, if positive, of the costs of removal minus the salvage value of the Participating TO's Interconnection Facilities.
- (s) Special Protection System ("SPS"): A system that reduces or trips generation under contingency outages to maintain system stability or to limit overloads on system facilities.
- (t) Units of Property: As described in FERC's "List of Units of Property for Use in Connection with Uniform System of Accounts Prescribed for Public Utilities and Licensees" in effect as of the date of this LGIA, and as such list may be amended from time to time.

9. Transmission Credits: Subject to Section 13(d) of this Appendix A, no Congestion Revenue Rights or repayment will be made pursuant to Articles 11.4 and 11.4.1 of the LGIA because this LGIA assumes that the Participating TO will up-front finance the Network Upgrades described in Section 2 of this Appendix A.

10. Security Amount for the Participating TO's Interconnection Facilities and Network Upgrades:

- (a) Pursuant to Article 11.5 and Appendix B of the LGIA, the Interconnection Customer shall:
 - (i) Provide Credit Support in the amount of \$2,325,000 in accordance with the table shown in Appendix A, Section 10(d), to cover the costs for constructing, procuring and installing the Participating TO's Interconnection Facilities. The disposition of any released Credit Support shall be directed by the Interconnection Customer.
 - (ii) Provide Credit Support in the amount of \$500,000 to cover the Participating TO's estimated costs to be incurred for approximately six months from the Effective Date associated with commencing design, final engineering, environmental related work, and the application for a permit to construct to the CPUC for the Network Upgrades listed in Appendix A, Section 2, until the Participating TO receives Abandoned Plant Approval.

- (iii) In the absence of Abandoned Plant Approval, provide additional Credit Support sufficient to cover the cost to complete the work for the Network Upgrades authorized pursuant to Article 5.5.2. The amount of additional Credit Support required shall be estimated at such time it is required by the Participating TO based upon the most recent cost information available to the Participating TO and will be reflected in an amendment to this LGIA.
- (b) In the absence of Abandoned Plant Approval, the Participating TO shall not perform any work on the Network Upgrades without sufficient Credit Support from the Interconnection Customer. The disposition of any Credit Support released by the Participating TO shall be directed by the Interconnection Customer. Credit Support related to the Network Upgrades shall be released by the Participating TO within thirty (30) Calendar Days of the Participating TO's receipt of Abandoned Plant Approval.
- (c) Upon notice by the Participating TO to the Interconnection Customer and the CAISO that the LGIA is being amended to provide for the Interconnection Customer to finance the Network Upgrades under Appendix A, Section 13(d)(i), or, that the Interconnection Customer has not continued to achieve the development milestones described in Appendix A, Section 13(d), Table 1, then the Interconnection Customer shall be required to comply, following amendment of this LGIA and acceptance by FERC, with the required posting of Credit Support for the Network Upgrades and to provide notice to the Parties of such compliance.
- (d) The Participating TO will accept Credit Support for the Participating TO's Interconnection Facilities in the form of a guarantee, a surety bond, letter of credit or other form of security that is reasonably acceptable to the Participating TO and is consistent with the Uniform Commercial Code of the applicable jurisdiction. The Credit Support must be satisfied by an entity that meets the creditworthiness requirement of the Participating TO. The Interconnection Customer shall provide to the Participating TO, the Credit Support, posted as follows and maintained pursuant to Article 11.5 of the LGIA:

• Date Due	Credit Support Amount
• 10/1/2012	\$116,000
• 10/1/2013	\$956,000
• 10/1/2014	\$1,253,000

- (e) The Participating TO will accept Credit Support for the Participating TO's Network Upgrades in the form of a guarantee, a surety bond, letter of credit or other form of security that is reasonably acceptable to the Participating TO and is consistent with the Uniform Commercial Code of the applicable jurisdiction. The Credit Support must be satisfied by an entity that meets the creditworthiness requirement of the Participating TO. The Interconnection Customer shall provide to the Participating TO, the Credit Support, posted as follows and maintained pursuant to Article 11.5 of the LGIA:

• Date Due	Credit Support Amount
• Within thirty (30) Calendar Days from the Effective Date	\$500,000

11. Security Amount for Estimated Tax Liability: Pursuant to Article 5.17.4 of the LGIA, the Interconnection Customer's estimated tax liability is as follows:

$(\text{Current Tax Rate} \times (\text{Gross Income Amount} - \text{Present Value of Tax Depreciation})) / (1 - \text{Current Tax Rate}) = 35\%$

Estimated tax liability = $35\% \times (\text{Interconnection Facilities Cost}) = 35\% \times (\$2,325,000) = \$813,750$

Interconnection Facilities Cost = \$2,325,000

Based upon the estimated tax liability, the Interconnection Customer shall provide Credit Support to the Participating TO in the form of a guarantee, a surety bond, letter of credit or other form of security that is reasonably acceptable to the Participating TO and is consistent with the Uniform Commercial Code of the applicable jurisdiction.

The security must be made by an entity that meets the creditworthiness requirement of the Participating TO. The Interconnection Customer shall provide to the Participating TO security, pursuant to Article 5.17.3 and Appendix B of the LGIA, posted as follows:

Date Due	Credit Support Amount
10/1/2012	\$40,600
10/1/2013	\$375,200
10/1/2014	\$813,750

12. Removal of the Participating TO's Interconnection Facilities: Following termination of the LGIA, the Participating TO will remove the Participating TO's Interconnection Facilities from service to the Interconnection Customer pursuant to Article 2.5 of the LGIA. On or before the date one year following termination of the LGIA, the Participating TO shall notify the Interconnection Customer whether the Participating TO intends to physically remove the Participating TO's Interconnection Facilities, or any part thereof. If the Participating TO intends to physically remove the Participating TO's Interconnection Facilities or any part thereof, then the Participating TO shall physically remove such facilities within two years from the date of notification of intent, and the Interconnection Customer shall pay the Removal Cost. If the Participating TO does not intend to physically remove the Participating TO's Interconnection Facilities, or any part thereof, then the Interconnection Customer shall have no obligation to pay such Removal Cost.

13. Charges:

- (a) The Interconnection Customer shall pay to the Participating TO the following charges in accordance with the LGIA: (i) Delivery Network Upgrades Payment;

- (ii) Interconnection Facilities Payment; (iii) payments for any Capital Additions; (iv) Interconnection Facilities Charge; (v) any reimbursable FERC fees pursuant to Section 13(g) of this Appendix A; (vi) Removal Cost pursuant to Article 2.4.3 of the LGIA and Section 11 of this Appendix A; (vii) termination charges pursuant to Article 2.4 of the LGIA, however to the extent that the costs of the Participating TO's Network Upgrades have received Abandoned Plant Approval, the Interconnection Customer shall not be responsible for those charges; (viii) disconnection costs pursuant to Article 2.5 of the LGIA; and (ix) suspension costs pursuant to Article 5.16 of the LGIA.
- (b) The Delivery Network Upgrades Cost, Interconnection Facilities Cost, Reliability Network Upgrades Cost, associated One-Time Cost and Removal Cost shall be compiled in accordance with Accounting Practice.
- (c) If, during the term of the LGIA, the Participating TO executes an agreement to provide service to another entity (other than retail load) which contributes to the need for the Participating TO's Interconnection Facilities, the charges due hereunder may be adjusted to appropriately reflect such service based on the Participating TO's cost allocation principles in effect at such time and shall be subject to FERC's approval.
- (d) The Participating TO commits to up-front finance the Network Upgrades Cost and the associated One-Time Cost for the Network Upgrades described in Section 2 of this Appendix A to the LGIA, contingent upon satisfactory receipt, as determined by the Participating TO, of the following:
- (i) Abandoned Plant Approval: If Participating TO has not received Abandoned Plant Approval within six (6) months of applying for such approval, the Participating TO (1) shall have the right to draw on the Credit Support, provided in accordance with Section 10(a) of this Appendix A, for the Interconnection Customer's share of the cost incurred by the Participating TO for the Network Upgrades as of such time, and (2) will work with the Interconnection Customer to amend this LGIA such that the Interconnection Customer shall be responsible for financing its share of the costs of the Network Upgrades, subject to FERC's acceptance or approval of the amended LGIA. In such event that the Participating TO has not received Abandoned Plant Approval within six (6) months as stated above, the Interconnection Customer shall make its election to receive Congestion Revenue Rights or repayment of the amount of up-front financing provided by the Interconnection Customer for Network Upgrades pursuant to Article 11.4 of the LGIA at the time this LGIA is amended.
- (ii) Continued achievement of development milestones by the Interconnection Customer, as described in Table 1 below:

Table 1: Participating TO and Interconnection Customer**Milestones
and Decision Points**

Group 1 Milestones and Decision Point #1	
Participating TO Milestone	Interconnection Customer Milestone
<ul style="list-style-type: none"> • Participating TO applies for Abandoned Plant Approval • Participating TO commences final design and engineering of the Network Upgrades 	<ul style="list-style-type: none"> • Interconnection Customer secures final Site Control as defined in the LGIP • Interconnection Customer has provided Financial Security in accordance with Section 10 of this Appendix A to the LGIA
<p>DECISION POINT #1: Following Participating TO's written notification of Participating TO's completion of all of its Group 1 milestones, the Interconnection Customer must demonstrate that it has completed all of its Group 1 milestones within 90 Calendar Days of the Participating TO's notification. Parties exercise options as outlined in Table 2.</p>	

Group 2 Milestones and Decision Point #2	
Participating TO Milestone	Interconnection Customer Milestone
<ul style="list-style-type: none"> • Participating TO receives Abandoned Plant Approval • Participating TO secures all required permits, licenses, and property rights for the Participating TO's Interconnection Facilities, Distribution Upgrades, and Participating TO's Reliability Network Upgrades. 	<ul style="list-style-type: none"> • Interconnection Customer secures all permits, licenses, and property rights required for the construction of the Generating Facility and Interconnection Customer's Interconnection Facilities
<p>DECISION POINT #2: Following Participating TO's written notification of Participating TO's completion of all of its Group 2 milestones, the Interconnection Customer must demonstrate that it has completed all of its Group 2 milestones within 90 Calendar Days of the Participating TO's notification. Such milestones are subject to modification upon approval by the Parties. Such approval shall not be unreasonably withheld. Parties exercise options as outlined in Table 2.</p>	

Group 3 Milestones and Decision Point #3	
Participating TO Milestone	Interconnection Customer Milestone
<ul style="list-style-type: none"> Participating TO provides notification of estimated start of construction at least six (6) months in advance of the estimated start of construction date, for the Participating TO's Interconnection Facilities, Distribution Upgrades, and Participating TO's Reliability Network Upgrades. 	<ul style="list-style-type: none"> Interconnection Customer selects Engineering and Procurement Contractor ("EPC") Interconnection Customer secures 100% of financing to construct the Generating Facility and the Interconnection Customer's Interconnection Facilities
<p>DECISION POINT #3: Following Participating TO's written notification of Participating TO's completion of all of its Group 3 milestones, the Interconnection Customer must demonstrate that it has completed all of its Group 3 milestones prior to the estimated start of construction date specified in the Participating TO's notification. Parties exercise options as outlined in Table 2.</p>	

Group 4 Milestones and Decision Point #4	
Participating TO Milestone	Interconnection Customer Milestone
<ul style="list-style-type: none"> Participating TO commences construction of the Participating TO's Reliability Network Upgrades 	<ul style="list-style-type: none"> Interconnection Customer commences construction of the Generating Facility and the Interconnection Customer's Interconnection Facilities
<p>DECISION POINT #4: Following Participating TO's written notification of Participating TO's completion of all of its Group 4 milestones, the Interconnection Customer must demonstrate that it has completed all of its Group 4 milestones within 30 Calendar Days of the Participating TO's notification. Parties exercise options as outlined in Table 2.</p>	

Group 5 Milestones and Decision Point #5	
Participating TO Milestone	Interconnection Customer Milestone
<ul style="list-style-type: none"> Participating TO energizes the Participating TO's Reliability Network Upgrades, enabling Commercial Operation of the Generating Facility 	<ul style="list-style-type: none"> Interconnection Customer achieves Initial Synchronization Date Interconnection Customer commences generating electricity for sale, excluding electricity generated during Trial Operation, of the entire Generating Facility
<p>DECISION POINT #5: Following Participating TO's written notification of Participating TO's completion of all of its Group 5 milestones, the Interconnection Customer must demonstrate that it has completed all of its Group 5 milestones within 90 Calendar Days of the Participating TO's notification. Parties exercise options as outlined in Table 2.</p>	

Table 2: Actions by the Parties at each Decision Point:

Table 2A- Participating TO has the following options:

At each Decision Point as outlined in Table 1 above, if the Interconnection Customer is current in meeting its milestones in Table 1 above (as such milestones may be adjusted due to the Interconnection Customer exercising option 2 in Table 2B below), the Participating TO shall confirm its commitment to finance Network Upgrades.

If the Interconnection Customer is not current in meeting its milestones as outlined in Table 1 (as such milestones may be adjusted due to the Interconnection Customer exercising option 2 in Table 2B below), due to its action or inaction, the Interconnection Customer shall provide written notice to the Participating TO with the reasons for such failure to meet the identified milestones and a plan for schedule recovery. The Interconnection Customer must use commercially Reasonable Efforts to cure its failure to satisfy the applicable milestones and to achieve schedule recovery within sixty (60) Calendar Days of the date of such notice. If the Interconnection Customer has failed to cure the milestone failure within said sixty (60) Calendar Day period, the Participating TO shall have the following options:

- 1) Confirm its commitment to finance the Network Upgrades (but have no obligation to do so).
- 2) Discontinue its commitment to finance the Network Upgrades, in which case the Network Upgrades may then be financed by the Interconnection Customer subject to Section 13(h) of Appendix A.

- 3) Extend the applicable deadline for the Interconnection Customer to satisfy the milestone requirement.
- 4) Terminate this LGIA, subject to the termination provisions in this LGIA and Section 13(h) of Appendix A.
- 5) Other actions mutually agreeable to both parties.

Table 2B – Interconnection Customer has the following options:

At each Decision Point as outlined in Table 1 above, if the Participating TO is current in meeting its milestones in Table 1 above, the Interconnection Customer shall confirm its commitment to develop its Generating Facility.

If the Participating TO is not current in meeting its milestones as outlined in Table 1, due to its action or inaction, the Participating TO shall provide written notice to the Interconnection Customer with the reasons for such failure to meet the identified milestones and a plan for schedule recovery. The Participating TO must use commercially Reasonable Efforts to cure of its failure to satisfy the applicable milestones and to achieve schedule recovery within sixty (60) Calendar Days of the date of such notice. If the Participating TO has failed to cure the milestone failure within said sixty (60) Calendar Day period, the Interconnection Customer shall have the following options:

- 1) Continue to develop its Generating Facility (but have no obligation to do so).
- 2) Adjust its development milestones in Table 1 above, on a day-for-day basis, as appropriate, to the Participating TO's new timetable(s).
- 3) Terminate this LGIA, subject to termination provisions in this LGIA and Section 13(h) of Appendix A.
- 4) Other actions mutually agreeable to both parties.

Upon a Party reaching a Decision Point described in Table 1 above, that Party shall provide written notice to the other Parties. At the time of such notice, a window of thirty (30) Calendar Days shall open and each Party shall have thirty (30) Calendar Days to notify the other Party of what, if any, option it has elected to take pursuant to Table 2. The Parties may extend this window by mutual agreement, and may exercise the Participating TO's option 5 and the Interconnection Customer's option 4 as well. If a Party does not exercise any option during the thirty (30) Calendar Day window, then it shall be deemed to have elected option 1.

The termination provisions provided in option 4 of Table 2A and option 3 of Table 2B above are in addition to, and not a replacement for, the termination provisions specified in Article 2.3 of this LGIA.

- (e) The determination of whether the Interconnection Customer has met its milestones outlined in Table 1 under Section 13(d) above shall be at the sole discretion of the Participating TO. The determination of whether the Participating TO has met its milestones outlined in Table 1 under Section 13(d) above shall be at the sole discretion of the Interconnection Customer. If there is a dispute as to whether the Interconnection Customer or Participating TO has met a milestone required in Table 1 under Section 13(d) above, such dispute shall be resolved pursuant to Article 27 of the LGIA.
- (f) The Participating TO is under no obligation to finance other network upgrades if the Network Upgrades are modified pursuant to the LGIP and such modification results in the Participating TO having to reaffirm Abandoned Plant Approval, as determined solely by the Participating TO, for the modified or incremental Network Upgrades. At its sole discretion, the Participating TO may seek reaffirmation of Abandoned Plant Approval for any modified or incremental Network Upgrades. If (i) the reaffirmation of Abandoned Plant Approval for the modified or incremental Network Upgrades is not reached within six (6) months of applying for such reaffirmation, or (ii) the Participating TO does not seek reaffirmation of Abandoned Plant Approval, the Participating TO shall have the right to amend this LGIA to provide that the Interconnection Customer shall be responsible for financing its share of the costs of the modified or incremental Network Upgrades, subject to FERC's acceptance or approval
- (g) If the Interconnection Customer does not meet any one of the milestones specified in Table 1 under Section 13(d) (as such milestones may be adjusted due to the Interconnection Customer exercising option 2 in Table 2B above), by the completion of the corresponding Participating TO milestone and decision point, this failure shall be considered a Breach of this LGIA, subject to the Default and Right to Terminate provisions under Article 17 of this LGIA. Each milestone in Table 1 of Section 13(d) shall be extended for each day that Force Majeure delays a Party from achieving such milestone.
- (h) Notwithstanding anything to the contrary in Table 2A under Section 13(d) or 13(g), the Participating TO shall not file to terminate this LGIA, as a result of Interconnection Customer missing a milestone in Table 1 under Section 13(d) if the Parties reasonably and in good faith negotiate an amendment of this LGIA to provide for Interconnection Customer-financing of the Network Upgrades within sixty (60) Calendar Days after the Participating TO's notification of the Participating TO exercising options 2 or 4 of Table 2A under Section 13(d) of Appendix A.
- (i) Each Party shall provide the other Party with a monthly status report, including all supporting documentation, to verify that Party's progress on the milestones outlined in Table 1 under Section 13(d) above.
- (j) The Participating TO shall endeavor to file with FERC for Abandoned Plant Approval within sixty (60) Calendar Days of execution and filing of this LGIA.
- (k) At no time will the Participating TO require payment from the Interconnection Customer for any Network Upgrades for which Abandoned Plant Approval has been obtained, provided that the costs of such Network Upgrades are

incurred while the Interconnection Customer is current with meeting its development milestones pursuant to Section 13(d).

14. Supplemental Billing and Payment Provisions:

- (a) Pursuant to Article 12.1 of the LGIA, the Participating TO shall submit to the Interconnection Customer invoices due for the preceding month for the Interconnection Facilities Payment.
- (b) Pursuant to Article 10.5 of the LGIA, commencing on or following the Interconnection Facilities Completion Date, each month the Participating TO will render bills to the Interconnection Customer for the Interconnection Facilities Charge. The Interconnection Facilities Charge payments shall initially be based on the estimated Interconnection Facilities Cost as specified in Section 15 of this Appendix A, and such payments shall be subject to later adjustment pursuant to Section 14(b)(i) and 14(b)(ii). The Interconnection Facilities Charge for the first and last month of service hereunder shall be pro-rated based on the number of days in which service was provided during said months.
 - (i) If the amounts paid for the Interconnection Facilities Charge are less than the amounts due for the Interconnection Facilities Charge as determined from the actual recorded Interconnection Facilities Cost, Participating TO will bill Interconnection Customer the difference between the amounts previously paid by Interconnection Customer and the amounts which would have been paid based on actual recorded costs, without interest, on the next regular billing.
 - (ii) If the amounts paid for the Interconnection Facilities Charge are greater than the amounts due for the Interconnection Facilities Charge as determined from the actual recorded Interconnection Facilities Cost, Participating TO will credit Interconnection Customer the difference between the amounts previously paid by Interconnection Customer and the amounts which would have been paid based on actual recorded costs, without interest, on the next regular billing.
- (c) In the event that any portion of Participating TO's Interconnection Facilities is not complete but, at the request of Interconnection Customer, Participating TO commences interconnection service under this LGIA notwithstanding the incomplete facilities, Participating TO shall commence billing, and Interconnection Customer shall pay, the Interconnection Facilities Charge commencing on the date that such service commences.
- (d) In accordance with Article 5.19.3 of the LGIA, the Participating TO shall submit to the Interconnection Customer invoices due for the preceding month for the payments due for Capital Additions, if any.

- (i) For Capital Additions that are the cost responsibility of the Interconnection Customer, prior to commencing work, the Participating TO will provide at least sixty (60) Calendar Days advance written notification to the Interconnection Customer, except that, at the Participating TO's sole discretion, the Participating TO may commence the work on the Capital Additions with either shorter advance written notification or written notification after the work has commenced if the Participating TO determines that the Capital Additions are required in accordance with safety or regulatory requirements or to preserve system integrity or reliability. The written notification will include the estimated cost of the Capital Additions, and the amount of and due date for the security, if any, required to be paid by the Interconnection Customer sufficient to cover the costs for constructing, procuring and installing the Capital Additions consistent with the applicable terms of Article 11.5 of the LGIA.
 - (ii) Except as provided in Section 8(c) above, if certain Participating TO's Interconnection Facilities are removed to accommodate Capital Additions and such removal results in a change in the Interconnection Facilities Cost, the Interconnection Facilities Charge shall be adjusted as of the in-service date of such Capital Additions to reflect the change in the Interconnection Facilities Cost.
 - (iii) Except as provided in Section 8(c) above, if Capital Additions result in an increase in the Interconnection Facilities Cost, then the Interconnection Facilities Charge shall be adjusted as of the in-service date of such Capital Additions to reflect the change in such costs.
- (e) As soon as reasonably practicable, but within twelve (12) months after the in-service date of any Capital Additions, the Participating TO shall provide an invoice of the final cost of the construction of the Capital Additions to the Interconnection Customer, and shall set forth such costs in sufficient detail to enable the Interconnection Customer to compare the actual costs with the estimates and to ascertain deviations, if any, from the cost estimates. The Participating TO shall refund to the Interconnection Customer any amount by which the payment made by the Interconnection Customer for estimated costs of the Capital Additions exceeds the actual costs of construction within thirty (30) Calendar Days of the issuance of such final construction invoice; or, in the event the actual costs of construction exceed the Interconnection Customer's payment made for the estimated costs of the Capital Additions, then the Interconnection Customer shall pay to the Participating TO any amount by which the actual costs of construction exceed the payment made by the Interconnection Customer for estimated costs within thirty (30) Calendar Days of the issuance of such final construction invoice.
- (f) If, in accordance with the removal of the Participating TO's Interconnection Facilities specified in Section 12 above, the Participating TO decides to physically remove the Participating TO's Interconnection Facilities, or any part thereof, the Participating TO shall render a bill to the Interconnection Customer

for the Removal Cost. The Interconnection Customer shall pay the Removal Cost in accordance with Article 2.4.3 of the LGIA. Such billing shall initially be based on the Participating TO's estimate of the Removal Cost. Within twelve (12) months following the removal of the Participating TO's Interconnection Facilities, or any part thereof, the Participating TO shall determine the actual Removal Cost and provide the Interconnection Customer with a final invoice. The Participating TO shall refund to the Interconnection Customer any amount by which the payment by the Interconnection Customer for the estimated Removal Cost exceeds the actual Removal Cost within thirty (30) Calendar Days of the issuance of such final invoice; or, in the event the actual Removal Cost exceeds the Interconnection Customer's payment for the estimated Removal Cost, then the Interconnection Customer shall pay to the Participating TO any amount by which the actual Removal Cost exceeds the payment by the Interconnection Customer for the estimated Removal Cost within thirty (30) Calendar Days of the issuance of such final invoice.

- (g) The Interconnection Customer shall reimburse the Participating TO for all fees and charges related to the FERC fees and annual charges provided in Sections 381 and 382 of the FERC's regulations (18 C.F.R. § 381 and 382), as such regulation may from time to time be amended, that are imposed on the Participating TO attributable to the service provided under the LGIA, or any amendments thereto. The Participating TO will render bills to the Interconnection Customer for any such fees and charges incurred since the preceding billing. As of the Effective Date, no such fees and charges have been imposed on the Participating TO attributable to the service provided under the LGIA.

15. Interconnection Facilities, Distribution Upgrades, Reliability Network Upgrades, and Delivery Network Upgrades Cost Summary:

(a) Estimated Cost:

Element-	Interconnection Facilities Cost	Reliability Network Upgrades Cost*	Distribution Upgrades Cost*	Interconnection Facilities One-Time Cost	Reliability Network Upgrades One-Time Cost	Delivery Network Upgrades One-Time Cost	Total Costs	ITCC**
Lugo-Pisgah 220kV transmission line loop into Jasper Substation		\$6,768,000			\$1,913,000		\$8,681,000	
Granite Mountain-Jasper 220kV Transmission Line	\$1,069,000						\$1,069,000	\$374,150
Jasper Substation	\$664,000	\$20,199,000					\$20,863,000	\$232,400
Jasper Substation Station Power and Light			\$914,000				\$914,000	
Pisgah Substation		\$386,000					\$386,000	
Lugo Substation		\$386,000					\$386,000	
Telecom Gen-Tie Line	\$494,000						\$494,000	\$172,900
Telecom Line Protection, SPS and RTU		\$7,102,000					\$7,102,000	
Power System Controls-	\$69,000	\$69,000					\$138,000	\$24,150
Corporate Real Estate		\$5,851,000					\$5,851,000	
Metering Services	\$29,000						\$29,000	\$10,150
Licensing & Environmental		\$3,306,000					\$3,306,000	
Total	\$2,325,000	\$44,067,000	\$914,000		\$1,913,000		\$49,219,000	\$813,750

* The Reliability Network Upgrades Cost, Distribution Upgrades Cost, Reliability Network Upgrades One-Time Cost, and Distribution Upgrades One-Time Cost are provided for information only at this time since the Participating TO has agreed to finance the Participating TO's Distribution Upgrades for station light and power, specified in Section 3, of this Appendix A, and the Participating TO's Reliability Network Upgrades, subject to Section 13(d) of this Appendix A.

** Note: Interconnection Facilities ITCC, estimated at \$813,750 will be provided by Interconnection Customer in accordance with Appendix A, Section 11.

(b) Actual Cost:

(TO BE INSERTED AFTER TRUE-UP OF ACTUAL COSTS)

Element	Interconnection Facilities Cost	Reliability Network Upgrades Cost	Distribution Upgrades Cost	Interconnection Facilities One-Time Cost	Reliability Network Upgrades One-Time Cost	Delivery Network Upgrades Cost	Total Cost	ITCC
Total								

16. Interconnection Facilities Charge:

Interconnection Facilities Charge = Customer-Financed Monthly Rate x (Interconnection Facilities Cost)

Effective	Customer-Financed Monthly Rate	Estimated		Actual	
		Estimated Interconnection Facilities Cost	Interconnection Facilities Charge Based on Estimated Cost	Actual Interconnection Facilities Cost	Interconnection Facilities Charge based on actual cost
As of the Interconnection Facilities Completion Date	0.38%	\$2,325,000	\$8,835.00	[to be inserted after true-up]	[to be inserted after true-up]

17. Estimate of Monthly Incurred Costs for the Participating TO's Interconnection Facilities, Distribution Upgrades and Network Upgrades:

An estimate of the monthly incurred costs is as shown below. [Note: This estimate assumes that the LGIA has been executed and work starts by November 15, 2010, to achieve an in-service date of sixty (60) months from the Effective Date.

Payment No.	Payment Due Date	Interconnection Facilities Cost (A)	Reliability Upgrades Cost (B)	Total Payment Amount (C = A+B)	ITCC (D=Ax0.35)
Prior Letter Agreement	Paid		270,000	270,000	
1	10/1/12	5,000		5,000	1,750

2	11/1/12	7,000		7,000	2,450
3	12/1/12	7,000		7,000	2,450
4	1/1/13	8,000		8,000	2,800
5	2/1/13	9,000		9,000	3,150
6	3/1/13	9,000		9,000	3,150
7	4/1/13	10,000		10,000	3,500
8	5/1/13	11,000		11,000	3,850
9	6/1/13	11,000		11,000	3,850
10	7/1/13	12,000		12,000	4,200
11	8/1/13	13,000		13,000	4,550
12	9/1/13	14,000		14,000	4,900
13	10/1/13	14,000		14,000	4,900
14	11/1/13	18,000		18,000	6,300
15	12/1/13	25,000		25,000	8,750
16	1/1/14	35,000		35,000	12,250
17	2/1/14	53,000		53,000	18,550
18	3/1/14	72,000		72,000	25,200
19	4/1/14	80,000		80,000	28,000
20	5/1/14	86,000		86,000	30,100
21	6/1/14	92,000		92,000	32,200
22	7/1/14	103,000		103,000	36,050
23	8/1/14	166,000		166,000	58,100
24	9/1/14	212,000		212,000	74,200
25	10/1/14	208,000		208,000	72,800
26	11/1/14	129,000		129,000	45,150
27	12/1/14	104,000		104,000	36,400

28	1/1/15	115,000		115,000	40,250
29	2/1/15	138,000		138,000	48,300
30	3/1/15	147,000		147,000	51,450
31	4/1/15	152,000		152,000	53,200
32	5/1/15	120,000		120,000	42,000
33	6/1/15	80,000		80,000	28,000
34	7/1/15	44,000		44,000	15,400
35	8/1/15	13,000		13,000	4,550
36	9/30/15	3,000		3,000	1,050
Total		\$ 2,325,000	\$270,000	\$ 2,595,000	\$ 813,750

All amounts shown above are in nominal dollars.

Delivery Network Upgrades Payment = (Delivery Network Upgrades Cost + associated One-Time Cost) = \$ 0.

Interconnection Facilities Payment = (Interconnection Facilities Cost + associated One-Time Cost) = \$2,325,000

Reliability Network Upgrades Payment = (Reliability Network Upgrades Cost + associated One-Time Cost) = \$ 0 since the Participating TO has agreed to finance the Participating TO's Reliability Network Upgrades, subject to Section 13(d) of this Appendix A.

*Reliability Network Upgrades Cost paid pursuant to the Letter Agreement will be refunded in full with interest within thirty (30) Calendar Days following receipt by the Participating TO of Abandoned Plant Approval from FERC.

ITCC will be provided by Interconnection Customer in accordance with Appendix A, Section 11.

18. Other Potential Facilities:

The Interconnection Customer understands and acknowledges that the Interconnection of the Granite Mountain Wind Farm Project is dependent upon certain network upgrades which are currently the cost responsibility of projects ahead of the Granite Mountain Wind Farm Project in the Interconnection Application queue. In the event (i) a project in the queue ahead of the Granite Mountain Wind Farm Project is withdrawn from the queue, or (ii) it is determined by the Participating TO or the CAISO that some or all of the network upgrades currently assigned to earlier-queued projects are no longer required by such projects, the Interconnection Customer may be responsible for an amount up to the maximum cost exposure of the network upgrades identified in this Appendix A, Section 18. Such additional

other potential facilities or network upgrades are taken from the Interconnection Facilities Study.

Furthermore, the Interconnection Customer may also be responsible for the cost of any additional facilities or modifications to the Participating TO's electric system required to interconnect the Granite Mountain Wind Farm Project as a result of the termination or amendment of another project's interconnection agreement. The Interconnection Customer's revised cost responsibility for the network upgrades, and for any such additional facilities or modifications, if any, would be reflected in an amendment to the LGIA. Such amendment shall be subject to FERC acceptance or approval.

While the Interconnection Customer is currently responsible for the Network Upgrades identified in Section 2 of this Appendix A to the LGIA, the Interconnection Customer may be responsible for all or a portion of the following other network upgrades, under the conditions described above.

1. Telecommunications:

Install approximately 30 miles of new fiber optic cable from Gale Substation to Pisgah Substation using an existing distribution pole line between the two facilities.

Element	Other Reliability Network Upgrades	Maximum Cost Exposure- Other Potential Facilities Cost
Telecommunications	\$2,966,000	\$2,966,000
Total	\$2,966,000	\$2,966,000

Appendix B To LGIA

Milestones

1. The Interconnection Customer's Selected Option: Pursuant to Article 5.1 of the LGIA, the Interconnection Customer has selected the Standard Option.

2. Milestone Dates:

<u>Item</u>	<u>Milestone</u>	<u>Responsible Party</u>	<u>Due Date</u>
(a)	Submit proof of insurance coverage in accordance with Article 18.3 of the LGIA	Interconnection Customer	Within ten (10) Calendar Days of the execution of this LGIA
(b)	Submittal of written authorization to proceed with design and procurement to the Participating TO and CAISO in accordance with Article 5.5.2 of the LGIA	Interconnection Customer	Within thirty (30) Calendar Days of the Effective Date
(c)	Submittal of security for the Participating TO's Interconnection Facilities to the Participating TO pursuant to Articles 5.5.3, 5.6.4 and 11.5 of the LGIA	Interconnection Customer	In accordance with the amounts and schedule as provided in Section 10 of Appendix A.
(d)	Submittal of written authorization to proceed with construction to the Participating TO and the CAISO pursuant to Article 5.6.3 of the LGIA	Interconnection Customer	Within Thirty (30) Calendar Days prior to the estimated SCE construction start date in Group 3 Milestones
(e)	Submittal of security for the estimated tax liability to the Participating TO pursuant to Article 5.17.3 of the LGIA	Interconnection Customer	In accordance with the amounts and schedule as provided in Section 11 of Appendix A.
(f)	Completion of the Participating		

	TO's Interconnection Facilities, Distribution Upgrades and Network Upgrades	Participating TO	Within sixty (60) months following the Effective Date ⁽¹⁾⁽²⁾
(g)	Submittal of initial specifications for the Interconnection Customer's Interconnection Facilities and Granite Mountain Wind Farm Project, including System Protection Facilities, to the Participating TO and the CAISO pursuant to Article 5.10.1 of the LGIA	Interconnection Customer	At least one hundred eighty (180) Calendar Days prior to the Initial Synchronization Date
(h)	Initial information submission which shall include the Participating TO's Transmission System information necessary to allow the Interconnection Customer to select equipment, in accordance with Article 24.2 of the LGIA	Participating TO	At least one hundred eighty (180) Calendar Days prior to Trial Operation
(i)	Updated information submission by the Interconnection Customer, including manufacturer information in accordance with Article 24.3 of the LGIA	Interconnection Customer	No later than one hundred eighty (180) Calendar Days prior to Trial Operation
(j)	Review of and comment on the Interconnection Customer's initial specifications pursuant to Article 5.10.1 of the LGIA	Participating TO and CAISO	Within thirty (30) Calendar Days of the Interconnection Customer's submission of initial specifications
(k)	Submittal of final specifications for the Interconnection Customer's Interconnection Facilities and Granite Mountain Wind Farm Project, including System Protection Facilities, to the Participating TO and the CAISO as specified in Article 5.10.1 of the LGIA	Interconnection Customer	At least ninety (90) Calendar Days prior to the Initial Synchronization Date.
(l)	Review of and comment on the Interconnection Customer's final specifications pursuant to Article 5.10.1 of the LGIA	Participating TO and CAISO	Within thirty (30) Calendar Days of the Interconnection Customer's submission of final

			specifications
(m)	Notification of Balancing Authority Area to the Participating TO and CAISO pursuant to Article 9.2	Interconnection Customer	At least three (3) months prior to the Initial Synchronization Date
(n)	Performance of a complete calibration test and functional trip test of the System Protection Facilities pursuant to Article 9.7.4.6 of the LGIA	Interconnection Customer and Participating TO	At least sixty (60) Calendar Days prior to the In-Service Date
(o)	In-Service Date	Interconnection Customer	October 24, 2013
(p)	Initial Synchronization Date/Trial Operation	Interconnection Customer	October 31, 2013
(q)	Performance of a complete calibration test and functional trip test of the System Protection Facilities pursuant to Article 9.7.4.6 of the LGIA	Interconnection Customer and Participating TO	At least sixty (60) Calendar Days prior to the Commercial Operation Date
(r)	Testing of the Participating TO's Interconnection Facilities, Distribution Upgrades and Network Upgrades and testing of the Interconnection Customer's Interconnection Facilities and Granite Mountain Wind Farm Project in accordance with Article 6.1 of the LGIA	Interconnection Customer and Participating TO	At least sixty (60) Calendar Days prior to the Initial Synchronization Date
(s)	Provide written approval to the Interconnection Customer for the operation of the Granite Mountain Wind Farm Project in accordance with Article 6.1 of the LGIA	Participating TO	At least fifteen (15) Calendar Days prior to the Initial Synchronization Date
(t)	Commercial Operation Date	Interconnection Customer	December 31, 2013
(u)	Submittal of "as-built" drawings, information and documents for the Interconnection Customer's Interconnection Facilities and the Electric Generating Units in accordance with Article 5.10.3 of the LGIA to the Participating TO and the CAISO	Interconnection Customer	Within one hundred twenty (120) Calendar Days after the Commercial Operation Date, unless otherwise agreed

The Interconnection Customer understands and acknowledges that such timeline is only an estimate and that equipment and material lead times, labor availability, outage coordination, regulatory approvals, right-of-way negotiations, or other unforeseen events could delay the actual in-service dates of the Participating TO's Interconnection Facilities, Distribution Upgrades, or Network Upgrades beyond those specified. The Participating TO shall not be liable for any cost or damage incurred by the Interconnection Customer because of any delay in the work provided for in this Agreement.

(1) If an approved Environmental Impact Study or Environmental Impact Report is received by Participating TO by June 1, 2011, then the milestone listed in Section 2(f) above may be reduced by twenty four (24) months.

(2) The Interconnection Customer requested an In-Service Date of October 1, 2013. The Participating TO recognizes that the Interconnection Customer desires an In-Service Date that is earlier than the target in-service date as indicated in Appendix B, Section 2(f) of the LGIA. The Participating TO will work with the Interconnection Customer to determine whether an earlier in-service date can be achieved using Reasonable Efforts, as determined solely by the Participating TO. The Participating TO has made preliminary estimates that the Interconnection Customer's proposed In-Service Date of October 1, 2013 may be achievable. Such determination will take into account factors including, but not limited to, safety, cost, impacts on other projects and customers, system priorities, and resource availability. If an earlier In-Service Date is determined to be feasible, the Participating TO will use Reasonable Efforts to achieve such earlier date; however, the Participating TO has no obligation to meet the Interconnection Customer's requested earlier In-Service Date.

If the Interconnection Customer suspends work pursuant to Article 5.16 of the LGIA, then all milestones for each Party set forth in this Appendix B shall be suspended during the suspension period. Upon the Interconnection Customer's request to recommence the work, the Parties shall negotiate in good faith new revised milestone dates for each milestone, taking into account the period of suspension and necessary re-studies, if required. Appendix B and any terms and conditions associated with the estimated costs and payment schedule, if necessary, shall be amended following the establishment of such revised milestone dates.

The Interconnection Customer also understands and agrees that the method of service required to interconnect the Granite Mountain Wind Farm Project may require re-evaluation due to the suspension of the project and changes to the Participating TO's electrical system or addition of new generation.

Appendix C To LGIA

Interconnection Details

- 1. Generating Facility:** All equipment and facilities comprising the Granite Mountain generating facility in San Bernardino County, at the site identified as N34.535W117.028, California, as disclosed by the Interconnection Customer in its Interconnection Request, which, upon revision, now consists of twenty 3MW Vestas V-90 wind turbine generators and the associated infrastructure and, step-up transformers, meters and metering equipment and appurtenant equipment (the “Granite Mountain Wind Farm Project”).

- 2. Interconnection Customer Operational Requirements.**
 - (a) Pursuant to Article 9.4 of the LGIA, the Interconnection Customer shall operate the Granite Mountain Wind Farm Project and the Interconnection Customer’s Interconnection Facilities in accordance with the CAISO Tariff, the WSCC Reliability Management System Agreement and NERC requirements, including NERC/WSCC reliability standards and Applicable Reliability Standards.

 - (b) The Granite Mountain Wind Farm Project shall be operated so as to prevent or protect against the following adverse conditions on the Participating TO’s electric system: inadvertent and unwanted re-energizing of a utility dead line or bus; interconnection while out of synchronization; overcurrent; voltage imbalance; ground faults; generated alternating current frequency outside permitted safe limits; poor power factor or reactive power outside permitted limits; and abnormal waveforms.

- 3. Interconnection Principles:**
 - (a) This LGIA provides for interconnection of a total capacity of 60 MW, resulting from the interconnection of the Granite Mountain Wind Farm Project, as described in Section 1 of this Appendix C. The Interconnection Customer acknowledges that if the Interconnection Customer wishes to increase the amount of interconnection capacity provided pursuant to this LGIA, the Interconnection Customer shall be required to submit a new Interconnection Request in accordance with the terms and conditions of the CAISO Tariff.

 - (b) The costs associated with any mitigation measures required to third party transmission systems resulting from the interconnection of the Granite Mountain Wind Farm Project to the Participating TO’s electrical system are not reflected in this LGIA. The Participating TO shall have no responsibility to pay costs associated with any such mitigation measures. If applicable,

- Interconnection Customer shall enter into an agreement with such third parties to address any required mitigation in accordance with Section 12.4 of the LGIP. There are no known third-party transmissions systems affected by the interconnection of the Granite Mountain Wind Farm Project
- (c) In the event the Participating TO's Interconnection Facilities are utilized to provide retail service to the Interconnection Customer in addition to the wholesale Interconnection service provided herein, and the Interconnection Customer fails to make payment for such retail service in accordance with the Participating TO's applicable retail tariffs, the Participating TO's Interconnection Facilities may be removed from service to the Interconnection Customer, subject to the notice and cure provisions of such retail tariffs, until payment is made by the Interconnection Customer pursuant to such retail tariffs.
 - (d) Review by the Participating TO of the electrical specifications, design, construction, operation, or maintenance of the Granite Mountain Wind Farm Project or the Interconnection Customer's Interconnection Facilities shall not constitute any representation as to the economic or technical feasibility, operational capability, or reliability of such facilities. The Interconnection Customer shall in no way represent to any third party that any such review by the Participating TO of such facilities, including, but not limited to, any review of the design, construction, operation, or maintenance of such facilities by the Participating TO, is a representation by the Participating TO as to the economic or technical feasibility, operational capability, or reliability of the Granite Mountain Wind Farm Project or the Interconnection Customer's Interconnection Facilities.
 - (e) The Participating TO's approval process specified in Article 6.1 of the LGIA will include verification that the required low-voltage ride-through and power factor correction equipment, if any, pursuant to Appendix H of this LGIA, have been installed.
 - (f) Interconnection Customer shall use Reasonable Efforts to work with applicable Governmental Authorities to include the Participating TO's Interconnection Facilities and/or Network Upgrades (where applicable) in all such environmental impact studies, where applicable. Interconnection Customer shall provide the results of such studies and approvals to Participating TO for use in Participating TO's application(s) to obtain the regulatory approvals required to be obtained by Participating TO for the construction, operation, and maintenance of the, Participating TO's Interconnection Facilities, Distribution Upgrades and Reliability Network Upgrades described in Appendix A of this LGIA.
 - (g) The Interconnection Customer is responsible for all costs associated with any necessary relocation of any Participating TO facilities as a result of the Granite Mountain Wind Farm Project and acquiring all property rights

necessary for the Interconnection Customer's Interconnection Facilities, including those required to cross the Participating TO's facilities and property. The relocation of Participating TO facilities or use of Participating TO property rights shall only be permitted upon written agreement between Participating TO and the Interconnection Customer. Any proposed relocation of Participating TO facilities or use of Participating TO property rights may require a study and/or evaluation, the cost of which would be borne by the Interconnection Customer, to determine whether such use may be accommodated. The terms and conditions of any such use of Participating TO facilities or property rights would be the subject of a separate agreement and any associated costs to the Interconnection Customer would not be considered a Network Upgrade and would not be refundable to the Interconnection Customer.

- (h) This LGIA does not address any requirements for standby power or temporary construction power that the Granite Mountain Wind Farm Project may require prior to the in-service date of the Interconnection Facilities. Should the Granite Mountain Wind Farm Project require standby power or temporary construction power from Participating TO prior to the in-service date of the Interconnection Facilities, the Interconnection Customer is responsible to make appropriate arrangements with Participating TO to receive and pay for such retail service.
- (i) An earlier Interconnection Request, CAISO queue #125 project triggered the need to install a new Cool Water–Lugo 220kV Transmission Line and also an SPS to trip off the CAISO #125 project under the outage of the new Coolwater-Lugo 220kV Transmission Line.

It is estimated at this time that, although the new Coolwater-Lugo 220kV Transmission Line is required for the CAISO queue #125 project, it will actually be constructed after the Jasper Substation is in service. At the time when the Cool Water–Lugo 220kV Transmission Line is installed, the line will be looped into the new Jasper Substation and reconfigured into the Cool Water–Jasper and Jasper–Lugo 220kV Transmission Lines.

The technical assessment study identified the need to modify the earlier SPS originally installed to trip off the CAISO queue #125 project under the outage of the Cool Water–Lugo 220kV Transmission Line to now trip off the Granite Mountain Wind Farm Project under the following outage:

- Jasper–Lugo 220kV Transmission Line

NOTES: The Granite Mountain Wind Farm Project is not responsible for the cost of the Cool Water-Lugo 220kV Transmission Line loop into Jasper Substation.

After the Cool Water–Jasper and Jasper-Lugo 220kV Transmission Lines are completed, the Granite Mountain Wind Farm Project will be required to

participate in the SPS described above, for the outage of the Jasper–Lugo 220kV Transmission Line.

4. Interconnection Operations:

- (a) The Interconnection Customer shall cause the Granite Mountain Wind Farm Project to participate in any SPS required in accordance with Applicable Reliability Standards and Good Utility Practice, to prevent thermal overloads and unstable conditions resulting from outages. Such participation shall be in accordance with applicable FERC regulations, and CAISO Tariff provisions and protocols. The Interconnection Customer will not be entitled to any compensation from the Participating TO, pursuant to the LGIA, for loss of generation output when (i) the Granite Mountain Wind Farm Project generation is reduced or tripped off-line due to implementation of the SPS; or (ii) such generation output is restricted in the event the SPS becomes inoperable. Pursuant to Good Utility Practice, the Participating TO will provide the Interconnection Customer advance notice of any required SPS.
- (b) The Interconnection Customer shall cause the Granite Mountain Wind Farm Project to participate in CAISO congestion management in accordance with CAISO Tariff and Scheduling Protocols.
- (c) Following outages of the Interconnection Facilities or the Granite Mountain Wind Farm Project, the Interconnection Customer shall not energize the Granite Mountain Wind Farm Project for any reason without specific permission from the Participating TO's and the CAISO's operations personnel. Such permission shall not be unreasonably withheld.
- (d) The Interconnection Customer shall maintain operating communications with the Participating TO's designated switching center and the CAISO. The operating communications shall include, but not be limited to, system parallel operation or separation, scheduled and unscheduled outages, equipment clearances, protective relay operations, and levels of operating voltage and reactive power.
- (e) Additional operational studies may be performed by the Participating TO on an as needed basis as directed by the CAISO, and at the Interconnection Customer's expense to confirm if any of the circuit breaker upgrades or replacements identified in the Interconnection Study as being triggered by queued ahead projects are required to be advanced in order to accommodate interconnection of the Granite Mountain Wind Farm Project. In the event that it is determined by the Participating TO that any such upgrades or replacements are required to be advanced in order to accommodate interconnection of the Granite Mountain Wind Farm Project, such advancement shall be addressed in accordance with Section 12.2.2 of the LGIP.

- 5. Compliance with Applicable Reliability Standards:** The Interconnection Customer shall comply with all Applicable Reliability Standards for its Interconnection Customer's Interconnection Facilities and the Granite Mountain Wind Farm Project. The Participating TO will not assume any responsibility for complying with mandatory reliability standards for such facilities and offers no opinion whether the Interconnection Customer must register with NERC. If required to register with NERC, the Interconnection Customer shall be responsible for complying with all Applicable Reliability Standards for its Interconnection Customer's Interconnection Facilities up to the Point of Change of Ownership as described in Section 4 of Appendix A of this LGIA.

Appendix D To LGIA

Security Arrangements Details

Infrastructure security of CAISO Controlled Grid equipment and operations and control hardware and software is essential to ensure day-to-day CAISO Controlled Grid reliability and operational security. FERC will expect the CAISO, all Participating TOs, market participants, and Interconnection Customers interconnected to the CAISO Controlled Grid to comply with the recommendations offered by the President's Critical Infrastructure Protection Board and, eventually, best practice recommendations from the electric reliability authority. All public utilities will be expected to meet basic standards for system infrastructure and operational security, including physical, operational, and cyber-security practices.

The Interconnection Customer shall meet the requirements for security implemented pursuant to the CAISO Tariff, including the CAISO's standards for information security posted on the CAISO's internet web site at the following internet address: <http://www.caiso.com/pubinfo/info-security/index.html>.

**Appendix E
To LGIA**

Commercial Operation Date

This Appendix E is a part of the LGIA.

[Date]

Mr. Stephen Rutty
Manager, Grid Assets
California Independent System Operator Corporation
151 Blue Ravine Road
Folsom, CA 95630

Mr. Robert Kott
Manager, Model and Contract Implementation
California Independent System Operator Corporation
151 Blue Ravine Road
Folsom, CA 95630

Mr. William Law
Manager, Grid Contracts Administration and Billing
Southern California Edison Company
P. O. Box 800
2244 Walnut Grove Avenue
Rosemead, California 91770

Re: Granite Wind, LLC – Granite Mountain Wind Farm Project Electric
Generating Unit

Dear Messrs. Rutty, Kott, and Law:

On **[Date]** **Granite Wind, LLC** has completed Trial Operation of Granite Mountain Wind Farm Project Unit No. _____. This letter confirms that Granite Wind, LLC commenced Commercial Operation of Granite Mountain Wind Farm Project Unit No. _____ at the Electric Generating Unit, effective as of **[Date plus one day]**.

Thank you.

[Signature]

[Interconnection Customer Representative]

cc: Linda Wright

Appendix F To LGIA

Addresses for Delivery of Notices and Billings

Notices:

1. General Notices:

CAISO	Participating TO	Interconnection Customer
Ms. Linda Wright 151 Blue Ravine Rd. Folsom, CA 95630	Manager, Grid Contracts Administration and Billing P. O. Box 600 Rosemead, CA 91770	c/o Renewable Energy System Americas Inc. 11101 W. 120 th Ave. Suite 400 Broomfield, Colorado 80021 Phone: 303-439-4200 Fax: 303-439-4299

2. Operating Communications and Notifications:

The CAISO, Participating TO and the Interconnection Customer shall provide for operating communications through their respective designated representatives as follows:

The Parties agree to exchange the following information ten (10) Calendar Days prior to the Initial Synchronization Date of the Granite Mountain Wind Farm Project:

CAISO	Participating TO	Interconnection Customer
		Granite Wind, LLC
CAISO Real Time Desk/24 Hour Telephone:	Grid Control Center/24 Hour Telephone:	*Operator Name and/or Title: Control Room Operator *24 Hour Telephone:
Alternate Phone:		*Operation Center Fax. No.: *E-mail:

3. Operational Matters, Force Majeure, and Outage Notices:

CAISO	Participating TO	Interconnection Customer
Name: Phone:	Name/Title: Phone:	Name/Title: Phone:

4. For Emergencies:

CAISO	Participating TO	Interconnection Customer
Name: Phone:	Name/Title: Phone:	Name/Title: Phone:

5. Billing and Payments:

CAISO	Participating TO	Interconnection Customer
Finance Dept. Mr. Dennis Estrada 151 Blue Ravine Rd. Folsom, CA 95630	Manager, Grid Contracts Administration and Billing P. O. Box 600 Rosemead, CA 91770	Mr. Brian Evans and Ms. Marcia Emmons 11101 W. 120 th Ave. Suite 400 Broomfield, Colorado 80021 Phone: 303-439-4200 Fax: 303-439-4299

6. Alternate Forms of Delivery of Notices (telephone, facsimile or e-mail):

CAISO	Participating TO	Interconnection Customer
lwright@caiso.com	Manager, Grid Contracts Administration and Billing Tel: (626) 302-9640 Fax: (626) 302-1152	Mr. Brian Evans and Ms. Marcia Emmons 11101 W. 120 th Ave. Suite 400 Broomfield, Colorado 80021 Phone: 303-439-4200 Fax: 303-439-4299

**Appendix G
To LGIA**

Execution of the Reliability Management System (“RMS”) Agreement below will be a condition subsequent to execution of this LGIA, and will be required only if the FERC does not approve of the CAISO’s proposal to eliminate the obligation of the Interconnection Customer to execute the RMS Agreement as set forth in Article 9.1 of this LGIA

Reliability Management System Agreement

**RELIABILITY MANAGEMENT SYSTEM AGREEMENT
by and between
CALIFORNIA INDEPENDENT SYSTEM OPERATOR CORPORATION
and
GRANITE WIND, LLC**

THIS RELIABILITY MANAGEMENT SYSTEM AGREEMENT (the "Agreement"), is entered into this _____ day of _____, 2010, by and between California Independent System Operator Corporation (the “Transmission Operator”) and Granite Wind, LLC (the “Generator”).

WHEREAS, there is a need to maintain the reliability of the interconnected electric systems encompassed by the WSCC in a restructured and competitive electric utility industry;

WHEREAS, with the transition of the electric industry to a more competitive structure, it is desirable to have a uniform set of electric system operating rules within the Western Interconnection, applicable in a fair, comparable and non-discriminatory manner, with which all market participants comply; and

WHEREAS, the members of the WSCC, including the Transmission Operator, have determined that a contractual Reliability Management System provides a reasonable, currently available means of maintaining such reliability.

NOW, THEREFORE, in consideration of the mutual agreements contained herein, and other good and valuable consideration, the receipt and sufficiency of which is hereby acknowledged, the Transmission Operator and the Generator agree as follows:

1. PURPOSE OF AGREEMENT

The purpose of this Agreement is to maintain the reliable operation of the Western Interconnection through the Generator’s commitment to comply with certain reliability standards.

2. DEFINITIONS

In addition to terms defined in the beginning of this Agreement and in the Recitals hereto, for purposes of this Agreement the following terms shall have the meanings set forth beside them below.

Control Area means an electric system or systems, bounded by interconnection metering and telemetry, capable of controlling generation to maintain its interchange schedule with other Control Areas and contributing to frequency regulation of the Western Interconnection.

FERC means the Federal Energy Regulatory Commission or a successor agency.

Member means any party to the WSCC Agreement.

Party means either the Generator or the Transmission Operator and

Parties means both of the Generator and the Transmission Operator.

Reliability Management System or **RMS** means the contractual reliability management program implemented through the WSCC Reliability Criteria Agreement, the WSCC RMS Agreement, this Agreement, and any similar contractual arrangement.

Western Interconnection means the area comprising those states and provinces, or portions thereof, in Western Canada, Northern Mexico and the Western United States in which Members of the WSCC operate synchronously connected transmission systems.

Working Day means Monday through Friday except for recognized legal holidays in the state in which any notice is received pursuant to Section 8.

WSCC means the Western Systems Coordinating Council or a successor entity.

WSCC Agreement means the Western Systems Coordinating Council Agreement dated March 20, 1967, as such may be amended from time to time.

WSCC Reliability Criteria Agreement means the Western Systems Coordinating Council Reliability Criteria Agreement dated June 18, 1999 among the WSCC and certain of its member transmission operators, as such may be amended from time to time.

WSCC RMS Agreement means an agreement between the WSCC and the Transmission Operator requiring the Transmission Operator to comply with the reliability criteria contained in the WSCC Reliability Criteria Agreement.

WSCC Staff means those employees of the WSCC, including personnel hired by the WSCC on a contract basis, designated as responsible for the administration of the RMS.

3. TERM AND TERMINATION

3.1 Term. This Agreement shall become effective [thirty (30) days after the date of issuance of a final FERC order accepting this Agreement for filing without requiring any changes to this Agreement unacceptable to either Party. Required changes to this Agreement shall be deemed unacceptable to a Party only if that Party provides notice to the other Party within fifteen (15) days of issuance of the applicable FERC order that such order is unacceptable].

[Note: if the interconnection agreement is not FERC jurisdictional, replace bracketed language with: [on the later of: (a) the date of execution; or (b) the effective date of the WSCC RMS Agreement.]]

3.2 Notice of Termination of WSCC RMS Agreement. The Transmission Operator shall give the Generator notice of any notice of termination of the WSCC RMS Agreement by the WSCC or by the Transmission Operator within fifteen (15) days of receipt by the WSCC or the Transmission Operator of such notice of termination.

3.3 Termination by the Generator. The Generator may terminate this Agreement as follows:

- (a) following the termination of the WSCC RMS Agreement for any reason by the WSCC or by the Transmission Operator, provided such notice is provided within forty-five (45) days of the termination of the WSCC RMS Agreement;
- (b) following the effective date of an amendment to the requirements of the WSCC Reliability Criteria Agreement that adversely affects the Generator, provided notice of such termination is given within forty-five (45) days of the date of issuance of a FERC order accepting such amendment for filing, provided further that the forty-five (45) day period within which notice of termination is required may be extended by the Generator for an additional forty-five (45) days if the Generator gives written notice to the Transmission Operator of such requested extension within the initial forty-five (45) day period; or
- (c) for any reason on one year's written notice to the Transmission Operator and the WSCC.

3.4 Termination by the Transmission Operator. The Transmission Operator may terminate this Agreement on thirty (30) days' written notice following the termination of the WSCC RMS Agreement for any reason by the WSCC or by the Transmission Operator, provided such notice is provided within thirty (30) days of the termination of the WSCC RMS Agreement.

3.5 Mutual Agreement. This Agreement may be terminated at any time by the mutual agreement of the Transmission Operator and the Generator.

4. COMPLIANCE WITH AND AMENDMENT OF WSCC RELIABILITY CRITERIA

4.1 Compliance with Reliability Criteria. The Generator agrees to comply with the requirements of the WSCC Reliability Criteria Agreement, including the applicable WSCC reliability criteria contained in Section IV of Annex A thereof, and, in the event of failure to comply, agrees to be subject to the sanctions applicable to such failure. Each and all of the provisions of the WSCC Reliability Criteria Agreement are hereby incorporated by reference into this Agreement as though set forth fully herein, and the Generator shall for all purposes be considered a Participant, and shall be entitled to all of the rights and privileges and be subject to all of the obligations of a Participant, under and in connection with the WSCC Reliability Criteria Agreement, including but not limited to the rights, privileges and obligations set forth in Sections 5, 6 and 10 of the WSCC Reliability Criteria Agreement.

4.2 Modifications to WSCC Reliability Criteria Agreement. The Transmission Operator shall notify the Generator within fifteen (15) days of the receipt of notice from the WSCC of the initiation of any WSCC process to modify the WSCC Reliability Criteria Agreement. The WSCC RMS Agreement specifies that such process shall comply with the procedures, rules, and regulations then applicable to the WSCC for modifications to reliability criteria.

4.3 Notice of Modifications to WSCC Reliability Criteria Agreement. If, following the process specified in Section 4.2, any modification to the WSCC Reliability Criteria Agreement is to take effect, the Transmission Operator shall provide notice to the Generator at least forty-five (45) days before such modification is scheduled to take effect.

4.4 Effective Date. Any modification to the WSCC Reliability Criteria Agreement shall take effect on the date specified by FERC in an order accepting such modification for filing.

4.5 Transfer of Control or Sale of Generation Facilities. In any sale or transfer of control of any generation facilities subject to this Agreement, the Generator shall as a condition of such sale or transfer require the acquiring party or transferee with respect to the transferred facilities either to assume the obligations of the Generator with respect to this Agreement or to enter into an agreement with the Control Area Operator in substantially the form of this Agreement.

5. SANCTIONS

5.1 Payment of Monetary Sanctions. The Generator shall be responsible for payment directly to the WSCC of any monetary sanction assessed against the Generator pursuant to this Agreement and the WSCC Reliability Criteria Agreement. Any such payment shall be made pursuant to the procedures specified in the WSCC Reliability Criteria Agreement.

5.2 Publication. The Generator consents to the release by the WSCC of information

related to the Generator's compliance with this Agreement only in accordance with the WSCC Reliability Criteria Agreement.

5.3 Reserved Rights. Nothing in the RMS or the WSCC Reliability Criteria Agreement shall affect the right of the Transmission Operator, subject to any necessary regulatory approval, to take such other measures to maintain reliability, including disconnection, which the Transmission Operator may otherwise be entitled to take.

6. THIRD PARTIES

Except for the rights and obligations between the WSCC and Generator specified in Sections 4 and 5, this Agreement creates contractual rights and obligations solely between the Parties. Nothing in this Agreement shall create, as between the Parties or with respect to the WSCC: (1) any obligation or liability whatsoever (other than as expressly provided in this Agreement), or (2) any duty or standard of care whatsoever. In addition, nothing in this Agreement shall create any duty, liability, or standard of care whatsoever as to any other party. Except for the rights, as a third-party beneficiary with respect to Sections 4 and 5, of the WSCC against Generator, no third party shall have any rights whatsoever with respect to enforcement of any provision of this Agreement. Transmission Operator and Generator expressly intend that the WSCC is a third-party beneficiary to this Agreement, and the WSCC shall have the right to seek to enforce against Generator any provisions of Sections 4 and 5, provided that specific performance shall be the sole remedy available to the WSCC pursuant to this Agreement, and Generator shall not be liable to the WSCC pursuant to this Agreement for damages of any kind whatsoever (other than the payment of sanctions to the WSCC, if so construed), whether direct, compensatory, special, indirect, consequential, or punitive.

7. REGULATORY APPROVALS

This Agreement shall be filed with FERC by the Transmission Operator under Section 205 of the Federal Power Act. In such filing, the Transmission Operator shall request that FERC accept this Agreement for filing without modification to become effective on the day after the date of a FERC order accepting this Agreement for filing. [This section shall be omitted for agreements not subject to FERC jurisdiction.]

8. NOTICES

Any notice, demand or request required or authorized by this Agreement to be given in writing to a Party shall be delivered by hand, courier or overnight delivery service, mailed by certified mail (return receipt requested) postage prepaid, faxed, or delivered by mutually agreed electronic means to such Party at the following address:

Transmission Operator

California ISO
Ms. Roni Reese
151 Blue Ravine Rd.
Folsom, CA 95630
Phone: (916) 608-7027
Fax: (916) 608-7292

Generator

Granite Wind, LLC
c/o Renewable Energy System Americas Inc.
11101 west 120th Ave.
Suite 400
Broomfield, Colorado 80021
Phone: 303-439-4200
Fax: 303-439-4299

The designation of such person and/or address may be changed at any time by either Party upon receipt by the other of written notice. Such a notice served by mail shall be effective upon receipt. Notice transmitted by facsimile shall be effective upon receipt if received prior to 5:00 p.m. on a Working Day, and if not received prior to 5:00 p.m. on a Working Day, receipt shall be effective on the next Working Day.

9. APPLICABILITY

This Agreement (including all appendices hereto and, by reference, the WSCC Reliability Criteria Agreement) constitutes the entire understanding between the Parties hereto with respect to the subject matter hereof, supersedes any and all previous understandings between the Parties with respect to the subject matter hereof, and binds and inures to the benefit of the Parties and their successors.

10. AMENDMENT

No amendment of all or any part of this Agreement shall be valid unless it is reduced to writing and signed by both Parties hereto. The terms and conditions herein specified shall remain in effect throughout the term and shall not be subject to change through application to the FERC or other governmental body or authority, absent the agreement of the Parties.

11. INTERPRETATION

Interpretation and performance of this Agreement shall be in accordance with, and shall be controlled by, the laws of the State of California but without giving effect to the provisions thereof relating to conflicts of law. Article and section headings are for convenience only and shall not affect the interpretation of this Agreement. References to articles, sections and appendices are, unless the context otherwise requires,

references to articles, sections and appendices of this Agreement.

12. PROHIBITION ON ASSIGNMENT

This Agreement may not be assigned by either Party without the consent of the other Party, which consent shall not be unreasonably withheld; provided that the Generator may without the consent of the WSCC assign the obligations of the Generator pursuant to this Agreement to a transferee with respect to any obligations assumed by the transferee by virtue of Section 4.5 of this Agreement.

13. SEVERABILITY

If one or more provisions herein shall be invalid, illegal or unenforceable in any respect, it shall be given effect to the extent permitted by applicable law, and such invalidity, illegality or unenforceability shall not affect the validity of the other provisions of this Agreement.

14. COUNTERPARTS

This Agreement may be executed in counterparts and each shall have the same force and effect as an original.

IN WITNESS WHEREOF, the Transmission Operator and the Generator have each caused this Reliability Management System Agreement to be executed by their respective duly authorized officers as of the date first above written.

California Independent System Operator Corporation

By: _____

Name: _____

Title: _____

Date: _____

Granite Wind, LLC

By: _____

Name: _____

Title: _____

Date: _____

Appendix H To LGIA

INTERCONNECTION REQUIREMENTS FOR A WIND GENERATING PLANT

Appendix H sets forth requirements and provisions specific to a wind generating plant. All other requirements of this LGIA continue to apply to wind generating plant interconnections.

A. Technical Standards Applicable to a Wind Generating Plant

i. Low Voltage Ride-Through (LVRT) Capability

A wind generating plant shall be able to remain online during voltage disturbances up to the time periods and associated voltage levels set forth in the standard below. The LVRT standard provides for a transition period standard and a post-transition period standard.

Transition Period LVRT Standard

The transition period standard applies to wind generating plants subject to FERC Order 661 that have either: (i) interconnection agreements signed and filed with FERC, filed with FERC in unexecuted form, or filed with FERC as non-conforming agreements between January 1, 2006 and December 31, 2006, with a scheduled In-Service Date no later than December 31, 2007, or (ii) wind generating turbines subject to a wind turbine procurement contract executed prior to December 31, 2005, for delivery through 2007.

1. Wind generating plants are required to remain in-service during three-phase faults with normal clearing (which is a time period of approximately 4 – 9 cycles) and single line to ground faults with delayed clearing, and subsequent post-fault voltage recovery to prefault voltage unless clearing the fault effectively disconnects the generator from the system. The clearing time requirement for a three-phase fault will be specific to the wind generating plant substation location, as determined by and documented by the Participating TO. The maximum clearing time the wind generating plant shall be required to withstand for a three-phase fault shall be 9 cycles at a voltage as low as 0.15 p.u., as measured at the high side of the wind generating plant step-up transformer (i.e. the transformer that steps the voltage up to the transmission interconnection voltage or “GSU”), after which, if the fault remains following the location-specific normal clearing time for three-phase faults, the wind generating plant may disconnect from the transmission system.
2. This requirement does not apply to faults that would occur between the wind generator terminals and the high side of the GSU or to faults that would result in a voltage lower than 0.15 per unit on the high side of the GSU serving the facility.

3. Wind generating plants may be tripped after the fault period if this action is intended as part of a special protection system.
4. Wind generating plants may meet the LVRT requirements of this standard by the performance of the generators or by installing additional equipment (e.g., Static VAR Compensator, etc.) within the wind generating plant or by a combination of generator performance and additional equipment.
5. Existing individual generator units that are, or have been, interconnected to the network at the same location at the effective date of the Appendix H LVRT Standard are exempt from meeting the Appendix H LVRT Standard for the remaining life of the existing generation equipment. Existing individual generator units that are replaced are required to meet the Appendix H LVRT Standard.

Post-transition Period LVRT Standard

All wind generating plants subject to FERC Order No. 661 and not covered by the transition period described above must meet the following requirements:

1. Wind generating plants are required to remain in-service during three-phase faults with normal clearing (which is a time period of approximately 4 – 9 cycles) and single line to ground faults with delayed clearing, and subsequent post-fault voltage recovery to prefault voltage unless clearing the fault effectively disconnects the generator from the system. The clearing time requirement for a three-phase fault will be specific to the wind generating plant substation location, as determined by and documented by the Participating TO. The maximum clearing time the wind generating plant shall be required to withstand for a three-phase fault shall be 9 cycles after which, if the fault remains following the location-specific normal clearing time for three-phase faults, the wind generating plant may disconnect from the CAISO Controlled Grid. A wind generating plant shall remain interconnected during such a fault on the CAISO Controlled Grid for a voltage level as low as zero volts, as measured at the high voltage side of the wind GSU.
2. This requirement does not apply to faults that would occur between the wind generator terminals and the high side of the GSU.
3. Wind generating plants may be tripped after the fault period if this action is intended as part of a special protection system.
4. Wind generating plants may meet the LVRT requirements of this standard by the performance of the generators or by installing additional equipment (e.g., Static VAR Compensator) within the wind generating plant or by a combination of generator performance and additional equipment.

5. Existing individual generator units that are, or have been, interconnected to the CAISO Controlled Grid at the same location at the effective date of the Appendix H LVRT Standard are exempt from meeting the Appendix H LVRT Standard for the remaining life of the existing generation equipment. Existing individual generator units that are replaced are required to meet the Appendix H LVRT Standard.

ii. Power Factor Design Criteria (Reactive Power)

A wind generating plant shall operate within a power factor within the range of 0.95 leading to 0.95 lagging, measured at the Point of Interconnection as defined in this LGIA in order to maintain a specified voltage schedule, if the Interconnection System Impact Study shows that such a requirement is necessary to ensure safety or reliability. The power factor range standard can be met by using, for example, power electronics designed to supply this level of reactive capability (taking into account any limitations due to voltage level, real power output, etc.) or fixed and switched capacitors, or a combination of the two, if agreed to by the Participating TO and CAISO. The Interconnection Customer shall not disable power factor equipment while the wind plant is in operation. Wind plants shall also be able to provide sufficient dynamic voltage support in lieu of the power system stabilizer and automatic voltage regulation at the generator excitation system if the Interconnection System Impact Study shows this to be required for system safety or reliability.

iii. Supervisory Control and Data Acquisition (SCADA) Capability

The wind plant shall provide SCADA capability to transmit data and receive instructions from the Participating TO and CAISO to protect system reliability. The Participating TO and CAISO and the wind plant Interconnection Customer shall determine what SCADA information is essential for the proposed wind plant, taking into account the size of the plant and its characteristics, location, and importance in maintaining generation resource adequacy and transmission system reliability in its area.