

December 29, 2010

The Honorable Kimberly D. Bose, Secretary
Federal Energy Regulatory Commission
888 First Street, N.E.
Washington, D.C. 20426

Re: **California Independent System Operator Corporation
Docket No. ER11-_____ -000**

**ISO Service Agreement No. 1805, Non-Conforming Large
Generator Interconnection Agreement**

Dear Secretary Bose:

The California Independent System Operator Corporation submits for Commission filing and acceptance the Large Generator Interconnection Agreement among the ISO, Southern California Edison Company, and AV Solar Ranch 1, LLC ("AV Solar").¹ On December 20, 2010, SCE filed this same LGIA in Docket No. ER11-2411-000 as non-conforming to the *pro forma* LGIA set forth in the ISO tariff. The ISO is submitting its own filing of this LGIA in order to have it accepted as a non-conforming service agreement of the ISO and to enter it into the ISO's eTariff system consistent with SCE's filing. The ISO requests that the Commission's consideration of this filing be consolidated with the Commission's review of SCE's filing of this same agreement, designated by SCE as its Service Agreement No. 96 under its Transmission Owner Tariff in Docket No. ER11-2411.

I. Variation from the *Pro Forma* LGIA

As described in SCE's filing in Docket No. ER11-2411, AV Solar's generating facility, known as the AV Solar One Project, is a 250 MW solar photovoltaic generating facility that was studied as part of the transition cluster, the first cluster to be processed under the ISO's Cluster LGIP. The generating facility will be interconnecting to a portion of SCE's Tehachapi renewable transmission project, at SCE's new Whirlwind Substation, which facilities are identified in the LGIA as reliability network upgrades and delivery network

¹ This filing is submitted pursuant to Section 205 of the Federal Power Act, 16 U.S.C. § 824d and Part 35 of the Commission's regulations, 18 C.F.R. Part 35, and in compliance with Order No. 714, *Electronic Tariff Filings*, FERC Stats. & Regs. ¶ 31,276 (2009). The ISO is also sometimes referred to as the CAISO.

upgrades needed for the interconnection of AV Solar's facility as a full capacity deliverability status facility. SCE's filing specifies that SCE has committed to provide up-front financing for these network upgrades and that the LGIA includes provisions in the LGIA consistent with previous Commission orders pertaining to SCE recovery of the costs of abandoned plant for the Tehachapi renewable transmission project from transmission ratepayers, a condition of SCE's up front funding commitment.²

As described in SCE's filing in Docket No. ER11-2411, the LGIA accounts for abandoned plant treatment by incorporating provisions in Article 2.4 of the LGIA that differ from the ISO's *pro forma* LGIA. As SCE's filing indicates, the modified provisions of Article 2.4 of the LGIA for the Solar Ranch One LGIA includes language in Article 2.4 of the ISO's *pro forma* LGIA to eliminate any ambiguity suggesting that an interconnection customer could face termination charges related to distribution upgrades or network upgrades for which full abandoned plant recovery had already been received. In this regard, added clarifying language states that "to the extent that the costs of the Participating TO's Network Upgrades have received Abandoned Plant Approval, the Interconnection Customer shall not be responsible for its share of those charges."³ The modified provisions of Article 2.4 reflect revisions directed by the Commission in orders on SCE's filings of non-conforming LGIAs in Dockets No. ER10-805 and ER10-1112, which concerned similar circumstances in which SCE committed to provide up-front financing for projects interconnecting to SCE's Tehachapi renewable transmission project.⁴ As these provisions of Article 2.4 are non-conforming to the ISO's *pro forma* LGIA, the ISO is submitting this separate filing of the Solar Ranch One LGIA, accompanied by a request that the Commission's review of the ISO's filing be consolidated with its review of SCE's filing of this same LGIA in Docket No. ER11-2411.

The LGIA has other non-conforming provisions which pertain to the contingencies of SCE's commitment to provide up-front financing for the network upgrades. These are

- (a) The definition of abandoned plant approval in Section 8(a) of Appendix A;

² SCE notes that it has filed for abandoned plant approval for the network upgrades set forth in the AV Solar One Project LGIA in Commission Docket No. EL11-10-000. AV Solar has now filed a motion in this docket with includes a request that the Commission clarify that SCE has already received abandoned plant treatment for the network upgrades detailed in the LGIA. (Motion to Intervene, Comments, and Answer in Opposition to Motions to Consolidate of AV Solar Ranch 1, LLC [filed December 27, 2010] at pp. 5-8.)

³ See SCE's transmittal letter (dated December 20, 2010) in Docket 2411 at p. 3 fn. 3.

⁴ The Commission accepted the filings by SCE and the ISO of LGIAs containing revised Article 2.4 by letter orders issued on September 17 and 23, 2010 in Dockets No. ER10-1958, 2122, and 2146.

- (b) SCE's commitment to up-front finance the cost of network upgrades and associated one-time cost in Section 13(d) of Appendix A;
- (c) The inclusion of milestones, including actions to be taken following completion or failure to compete milestones, in Sections 13(d), (e), (g), (h), (i) and (m) of Appendix A;
- (d) Limits on SCE's commitment to finance the network upgrades required for the generating facility in Section 13(f) of Appendix A;
- (e) SCE's commitment to file for abandoned plant approval within sixty (60) calendar days of the execution and filing of the LGIA, in Section 13(f) of Appendix A; and
- (f) The option of the Interconnection Customer to finance its share of the Network Upgrades if unconditional acceptance of the LGIA is not received by March 31, 2011.

The ISO is filing the AV Solar One Project LGIA as non-conforming ISO Service Agreement No.1805 in order to have it accepted as a non-conforming service agreement of the ISO and to ensure that its eTariff records of non-conforming service agreements to which both it and SCE are parties are consistent with those of SCE.

II. Effective Date

In SCE's filing of the AV Solar One Project LGIA in Docket No. ER11-2411, SCE requested an effective date of December 21, 2010 for this LGIA. The ISO requests that the Commission specify that same effective date for the ISO's filing of this same LGIA in the instant proceeding.

To accommodate the foregoing requested effective date, the ISO respectfully requests waiver, pursuant to Section 35.11 of the Commission's regulations (18 C.F.R. § 35.11), of the 60-day notice requirement contained in Section 35.3 of the Commission's regulations (18 C.F.R. § 35.3), in order to permit the LGIA to become effective as of the requested effective date. Good cause exists in that such waiver will permit the SCE and ISO filings of this LGIA to be effective on the same date. Granting the waiver will be consistent with prior Commission orders and the implementation by all parties to the LGIA pursuant to those orders. No harm will result to any entity from the specified effective date for the LGIA. Granting the requested waiver, therefore, is appropriate.

III. Expenses

No expense or cost associated with this filing has been alleged or judged in any judicial or administrative proceeding to be illegal, duplicative, unnecessary, or demonstratively the product of discriminatory employment practices.

IV. Service

The ISO has served copies of this transmittal letter and all attachments on the California Public Utilities Commission, the California Energy Commission, SCE, AV Solar, and the parties to Docket No. ER11-2411. In addition, the ISO is posting this transmittal letter and all attachments on the ISO's website.

The following are enclosed for filing:

- (1) this transmittal letter; and
- (2) a copy of the executed version of the non-conforming LGIA for AV Solar One Project.

V. Correspondence

The ISO requests that all correspondence, pleadings and other communications concerning this filing be served upon the following:

Baldassaro "Bill" Di Capo*
Senior Counsel
California Independent System
Operator Corporation
151 Blue Ravine Road
Folsom, CA 95630
Tel: (916) 608-7157
Fax: (916) 608-7222
E-mail: bdicapo@caiso.com

* Individual designated for service pursuant to Rule 203(b)(3),
18 C.F.R. § 203(b)(3).

VI. Conclusion

The ISO respectfully requests that the Commission accept this filing and permit the AV Solar One Project LGIA to be effective as of the date requested. If there are any questions concerning this filing, please contact the undersigned.

Respectfully submitted,

/s/ Baldassaro "Bill" Di Capo

Nancy Saracino

General Counsel

Sidney Davies

Assistant General Counsel

Baldassaro "Bill" Di Capo

Senior Counsel

California Independent System

Operator Corporation

151 Blue Ravine Road

Folsom, CA 95630

Tel: (916) 608-7157

Fax: (916) 608-7222

bdicapo@caiso.com

Attorneys for the California Independent
System Operator Corporation

LARGE GENERATOR INTERCONNECTION AGREEMENT (LGIA)

AMONG

AV SOLAR RANCH 1, LLC

AND

SOUTHERN CALIFORNIA EDISON COMPANY

AND

CALIFORNIA INDEPENDENT SYSTEM OPERATOR CORPORATION

(AV Solar One Project)

TABLE OF CONTENTS

ARTICLE 1. DEFINITIONS	2
ARTICLE 2. EFFECTIVE DATE, TERM AND TERMINATION	10
2.1 Effective Date	10
2.2 Term of Agreement	10
2.3 Termination Procedures.....	10
2.3.1 Written Notice.....	10
2.3.2 Default.....	10
2.3.3 Suspension of Work.....	10
2.3.4.....	10
2.4 Termination Costs.....	10
2.4.1	11
2.4.2.....	12
2.4.3.....	12
2.5 Disconnection	12
2.6 Survival	12
ARTICLE 3. REGULATORY FILINGS AND CAISO TARIFF COMPLIANCE	12
3.1 Filing	12
3.2 Agreement Subject to CAISO Tariff	12
3.3 Relationship Between this LGIA and the CAISO Tariff	13
3.4 Relationship Between this LGIA and the QF PGA	13
ARTICLE 4. SCOPE OF SERVICE	13
4.1 Interconnection Service	13
4.2 Provision of Service	13
4.3 Performance Standards	13
4.4 No Transmission Service	14
4.5 Interconnection Customer Provided Services	14
ARTICLE 5. INTERCONNECTION FACILITIES ENGINEERING, PROCUREMENT, AND CONSTRUCTION	14
5.1 Options	14
5.1.1 Standard Option	14
5.1.2 Alternate Option	15
5.1.3 Option to Build.....	15
5.1.4 Negotiated Option	15
5.2 General Conditions Applicable to Option to Build	16
5.3 Liquidated Damages	18
5.4 Power System Stabilizers	19
5.5 Equipment Procurement	19
5.5.1	19
5.5.2.....	19
5.5.3.....	19

5.6	Construction Commencement	19
	5.6.1.....	20
	5.6.2.....	20
	5.6.3.....	20
	5.6.4.....	20
5.7	Work Progress	20
5.8	Information Exchange	20
5.9	Limited Operation	20
5.10	Interconnection Customer's Interconnection Facilities	21
	5.10.1 Large Generating Facility and Interconnection Customer's Interconnection Facilities Specifications.....	21
	5.10.2 Participating TO's and CAISO's Review.....	21
	5.10.3 Interconnection Customer's Interconnection Facilities Construction	21
	5.10.4 Interconnection Customer to Meet Requirements of the Participating TO's Interconnection Handbook	22
5.11	Participating TO's Interconnection Facilities Construction	22
5.12	Access Rights	22
5.13	Lands of Other Property Owners	23
5.14	Permits.....	23
5.15	Early Construction of Base Case Facilities	23
5.16	Suspension	23
5.17	Taxes.....	24
	5.17.1 Interconnection Customer Payments Not Taxable.....	24
	5.17.2 Representations and Covenants	24
	5.17.3 Indemnification for the Cost Consequences of Current Tax Liability Imposed Upon the Participating TO	25
	5.17.4 Tax Gross-Up Amount	26
	5.17.5 Private Letter Ruling or Change or Clarification of Law.....	27
	5.17.6 Subsequent Taxable Events	27
	5.17.7 Contests.....	27
	5.17.8 Refund	28
	5.17.9 Taxes Other Than Income Taxes.....	29
5.18	Tax Status	30
5.19	Modification.....	30
	5.19.1 General	30
	5.19.2 Standards.....	31
	5.19.3 Modification Costs.....	31
ARTICLE 6.	TESTING AND INSPECTION.....	31
6.1	Pre-Commercial Operation Date Testing and Modifications	31
6.2	Post-Commercial Operation Date Testing and Modifications.....	31
6.3	Right to Observe Testing	32
6.4	Right to Inspect.....	32
ARTICLE 7.	METERING	32

7.1	General	32
7.2	Check Meters.....	33
7.3	Participating TO Retail Metering	33
ARTICLE 8.	COMMUNICATIONS	33
8.1	Interconnection Customer Obligations	33
8.2	Remote Terminal Unit	33
8.3	No Annexation	34
ARTICLE 9.	OPERATIONS	34
9.1	General	34
9.2	Balancing Authority Area Notification.....	34
9.3	CAISO and Participating TO Obligations	34
9.4	Interconnection Customer Obligations	35
9.5	Start-Up and Synchronization	35
9.6	Reactive Power.....	35
9.6.1	Power Factor Design Criteria	35
9.6.2	Voltage Schedules	35
9.6.2.1	Governors and Regulators.....	36
9.6.2.2	Loss of Voltage Control and Governor Control for Asynchronous Generating Facilities	36
9.6.3	Payment for Reactive Power.....	37
9.7	Outages and Interruptions	37
9.7.1	Outages	37
9.7.1.1	Outage Authority and Coordination.....	37
9.7.1.2	Outage Schedules	37
9.7.1.3	Outage Restoration.....	38
9.7.2	Interruption of Service	38
9.7.2.1	38
9.7.2.2	38
9.7.2.3	38
9.7.2.4	39
9.7.2.5	39
9.7.3	Under-Frequency and Over-Frequency Conditions.....	39
9.7.4	System Protection and Other Control Requirements	39
9.7.4.1	System Protection Facilities.....	39
9.7.4.2	40
9.7.4.3	40
9.7.4.4	40
9.7.4.5	40
9.7.4.6	40
9.7.5	Requirements for Protection	40
9.7.6	Power Quality.....	41
9.8	Switching and Tagging Rules	41
9.9	Use of Interconnection Facilities by Third Parties	41
9.9.1	Purpose of Interconnection Facilities	41

9.9.2	Third Party Users	42
9.10	Disturbance Analysis Data Exchange	42
ARTICLE 10.	MAINTENANCE	42
10.1	Participating TO Obligations	42
10.2	Interconnection Customer Obligations	42
10.3	Coordination	42
10.4	Secondary Systems	43
10.5	Operating and Maintenance Expenses	43
ARTICLE 11.	PERFORMANCE OBLIGATION	43
11.1	Interconnection Customer's Interconnection Facilities	43
11.2	Participating TO's Interconnection Facilities	43
11.3	Network Upgrades and Distribution Upgrades	43
11.4	Transmission Credits	44
11.4.1	Repayment of Amounts Advanced for Network Upgrades	44
11.4.2	Special Provisions for Affected Systems	44
11.4.3	45
11.5	Provision of Security	45
11.5.1	45
11.5.2	45
11.5.3	45
11.6	Interconnection Customer Compensation	45
11.6.1	Interconnection Customer Compensation for Actions During Emergency Condition	45
ARTICLE 12.	INVOICE	46
12.1	General	46
12.2	Final Invoice	46
12.3	Payment	47
12.4	Disputes	47
ARTICLE 13.	EMERGENCIES	47
13.1	[Reserved]	47
13.2	Obligations	47
13.3	Notice	47
13.4	Immediate Action	48
13.5	CAISO and Participating TO Authority	48
13.5.1	General	48
13.5.2	Reduction and Disconnection	49
13.6	Interconnection Customer Authority	49
13.7	Limited Liability	49
ARTICLE 14.	REGULATORY REQUIREMENTS AND GOVERNING LAWS	49
14.1	Regulatory Requirements	49
14.2	Governing Law	50

14.2.1.....	50
14.2.2.....	50
14.2.3.....	50
ARTICLE 15. NOTICES.....	50
15.1 General.....	50
15.2 Billings and Payments.....	50
15.3 Alternative Forms of Notice.....	50
15.4 Operations and Maintenance Notice.....	51
ARTICLE 16. FORCE MAJEURE.....	51
16.1 Force Majeure	51
16.1.1.....	51
16.1.2.....	51
ARTICLE 17. DEFAULT	51
17.1 Default	51
17.1.1 General	51
17.1.2 Right to Terminate.....	52
ARTICLE 18. INDEMNITY, CONSEQUENTIAL DAMAGES, AND INSURANCE	52
18.1 Indemnity	52
18.1.1 Indemnified Party	52
18.1.2 Indemnifying Party	52
18.1.3 Indemnity Procedures	52
18.2 Consequential Damages.....	53
18.3 Insurance	53
18.3.1.....	53
18.3.2.....	54
18.3.3.....	54
18.3.4.....	54
18.3.5.....	54
18.3.6.....	54
18.3.7.....	55
18.3.8.....	55
18.3.9.....	55
18.3.10.....	55
18.3.11.....	55
ARTICLE 19. ASSIGNMENT	55
19.1 Assignment	55
ARTICLE 20. SEVERABILITY	56
20.1 Severability	56
ARTICLE 21. COMPARABILITY	56

21.1	Comparability	56
ARTICLE 22.	CONFIDENTIALITY	57
22.1	Confidentiality	57
22.1.1	Term	57
22.1.2	Scope	57
22.1.3	Release of Confidential Information	57
22.1.4	Rights	58
22.1.5	No Warranties	58
22.1.6	Standard of Care	58
22.1.7	Order of Disclosure	58
22.1.8	Termination of Agreement	59
22.1.9	Remedies	59
22.1.10	Disclosure to FERC, its Staff, or a State	59
22.1.11	59
ARTICLE 23.	ENVIRONMENTAL RELEASES	60
23.1	60
ARTICLE 24.	INFORMATION REQUIREMENTS	60
24.1	Information Acquisition.....	60
24.2	Information Submission by Participating TO	60
24.3	Updated Information Submission by Interconnection Customer	61
24.4	Information Supplementation	61
ARTICLE 25.	INFORMATION ACCESS AND AUDIT RIGHTS	62
25.1	Information Access	62
25.2	Reporting of Non-Force Majeure Events.....	62
25.3	Audit Rights	63
25.3.1	63
25.3.2	63
25.4	Audit Rights Periods	63
25.4.1	Audit Rights Period for Construction-Related Accounts and Records	63
25.4.2	Audit Rights Period for All Other Accounts and Records	63
25.5	Audit Results.....	64
25.5.1	64
ARTICLE 26.	SUBCONTRACTORS	64
26.1	General	64
26.2	Responsibility of Principal	64
26.3	No Limitation by Insurance	64
ARTICLE 27.	DISPUTES	65
27.1	Submission	65

27.2	External Arbitration Procedures	65
27.3	Arbitration Decisions	65
27.4	Costs.....	66
ARTICLE 28. REPRESENTATIONS, WARRANTIES AND COVENANTS		66
28.1	General	66
28.1.1	Good Standing	66
28.1.2	Authority.....	66
28.1.3	No Conflict	66
28.1.4	Consent and Approval.....	67
ARTICLE 29. [RESERVED].....		67
ARTICLE 30. MISCELLANEOUS.....		67
30.1	Binding Effect.....	67
30.2	Conflicts	67
30.3	Rules of Interpretation.....	67
30.4	Entire Agreement.....	68
30.5	No Third Party Beneficiaries	68
30.6	Waiver.....	68
30.7	Headings.....	68
30.8	Multiple Counterparts.....	68
30.9	Amendment	68
30.10	Modification by the Parties.....	68
30.11	Reservation of Rights.....	69
30.12	No Partnership.....	70
30.13	Joint and Several Obligations	70
Appendices		71
Appendix A	Interconnection Facilities, Network Upgrades and Distribution Upgrades	
Appendix B	Milestones	
Appendix C	Interconnection Details	
Appendix D	Security Arrangements Details	
Appendix E	Commercial Operation Date	
Appendix F	Addresses for Delivery of Notices and Billings	
Appendix G	Interconnection Customer's Proportional Share of Costs of Network Upgrades for Applicable Project Group	
Appendix H	Interconnection Requirements For An Asynchronous Generating Facility	

LARGE GENERATOR INTERCONNECTION AGREEMENT

AV SOLAR RANCH 1, LLC

SOUTHERN CALIFORNIA EDISON COMPANY

CALIFORNIA INDEPENDENT SYSTEM OPERATOR CORPORATION

THIS LARGE GENERATOR INTERCONNECTION AGREEMENT (“LGIA”) is made and entered into this _____ day of _____ 2010, by and among AV Solar Ranch 1, LLC, a limited liability company organized and existing under the laws of the State of Delaware (“**Interconnection Customer**” with a Large Generating Facility), Southern California Edison Company, a corporation organized and existing under the laws of the State of California (“**Participating TO**”), and California Independent System Operator Corporation, a California nonprofit public benefit corporation organized and existing under the laws of the State of California (“**CAISO**”). Interconnection Customer, Participating TO, and CAISO each may be referred to as a “Party” or collectively as the “Parties.”

RECITALS

WHEREAS, CAISO exercises Operational Control over the CAISO Controlled Grid; and

WHEREAS, the Participating TO owns, operates, and maintains the Participating TO’s Transmission System; and

WHEREAS, Interconnection Customer intends to own, lease and/or control and operate the Generating Facility identified as a Large Generating Facility in Appendix C to this LGIA; and

WHEREAS, Interconnection Customer, Participating TO, and CAISO have agreed to enter into this LGIA for the purpose of interconnecting the Large Generating Facility with the Participating TO’s Transmission System;

NOW, THEREFORE, in consideration of and subject to the mutual covenants contained herein, it is agreed:

When used in this LGIA, terms with initial capitalization that are not defined in Article 1 shall have the meanings specified in the Article in which they are used.

ARTICLE 1. DEFINITIONS

Adverse System Impact shall mean the negative effects due to technical or operational limits on conductors or equipment being exceeded that may compromise the safety and reliability of the electric system.

Affected System shall mean an electric system other than the CAISO Controlled Grid that may be affected by the proposed interconnection, including the Participating TO's electric system that is not part of the CAISO Controlled Grid.

Affiliate shall mean, with respect to a corporation, partnership or other entity, each such other corporation, partnership or other entity that directly or indirectly, through one or more intermediaries, controls, is controlled by, or is under common control with, such corporation, partnership or other entity.

Applicable Laws and Regulations shall mean all duly promulgated applicable federal, state and local laws, regulations, rules, ordinances, codes, decrees, judgments, directives, or judicial or administrative orders, permits and other duly authorized actions of any Governmental Authority.

Applicable Reliability Council shall mean the Western Electricity Coordinating Council or its successor.

Applicable Reliability Standards shall mean the requirements and guidelines of NERC, the Applicable Reliability Council, and the Balancing Authority Area of the Participating TO's Transmission System to which the Generating Facility is directly connected, including requirements adopted pursuant to Section 215 of the Federal Power Act.

Asynchronous Generating Facility shall mean an induction, doubly-fed, or electronic power generating unit(s) that produces 60 Hz (nominal) alternating current.

Balancing Authority shall mean the responsible entity that integrates resource plans ahead of time, maintains load-interchange-generation balance within a Balancing Authority Area, and supports Interconnection frequency in real time.

Balancing Authority Area shall mean the collection of generation, transmission, and loads within the metered boundaries of the Balancing Authority. The Balancing Authority maintains load-resource balance within this area.

Base Case shall mean the base case power flow, short circuit, and stability data bases used for the Interconnection Studies.

Breach shall mean the failure of a Party to perform or observe any material term or condition of this LGIA.

Breaching Party shall mean a Party that is in Breach of this LGIA.

Business Day shall mean Monday through Friday, excluding federal holidays and the day after Thanksgiving Day.

CAISO Controlled Grid shall mean the system of transmission lines and associated facilities of the parties to the Transmission Control Agreement that have been placed under the CAISO's Operational Control.

CAISO Tariff shall mean the CAISO's tariff, as filed with FERC, and as amended or supplemented from time to time, or any successor tariff.

Calendar Day shall mean any day including Saturday, Sunday or a federal holiday.

Commercial Operation shall mean the status of an Electric Generating Unit or project phase at a Generating Facility that has commenced generating electricity for sale, excluding electricity generated during Trial Operation.

Commercial Operation Date of an Electric Generating Unit or project phase shall mean the date on which the Electric Generating Unit or project phase at the Generating Facility commences Commercial Operation as agreed to by the applicable Participating TO, the CAISO, and the Interconnection Customer pursuant to Appendix E to this LGIA, and in accordance with the implementation plan agreed to by the Participating TO and the CAISO for multiple individual Electric Generating Units or project phases at a Generating Facility where an Interconnection Customer intends to establish separate Commercial Operation Dates for those Electric Generating Units or project phases.

Confidential Information shall mean any confidential, proprietary or trade secret information of a plan, specification, pattern, procedure, design, device, list, concept, policy or compilation relating to the present or planned business of a Party, which is designated as confidential by the Party supplying the information, whether conveyed orally, electronically, in writing, through inspection, or otherwise, subject to Article 22.1.2.

Default shall mean the failure of a Breaching Party to cure its Breach in accordance with Article 17 of this LGIA.

Distribution System shall mean those non-CAISO-controlled transmission and distribution facilities owned by the Participating TO.

Distribution Upgrades shall mean the additions, modifications, and upgrades to the Participating TO's Distribution System. Distribution Upgrades do not include Interconnection Facilities.

Effective Date shall mean the date on which this LGIA becomes effective upon execution by all Parties subject to acceptance by FERC, or if filed unexecuted, upon the date specified by FERC.

Electric Generating Unit shall mean an individual electric generator and its associated plant and apparatus whose electrical output is capable of being separately identified and metered.

Emergency Condition shall mean a condition or situation: (1) that in the judgment of the Party making the claim is imminently likely to endanger life or property; or (2) that, in the case of the CAISO, is imminently likely (as determined in a non-discriminatory manner) to cause a material adverse effect on the security of, or damage to, the CAISO Controlled Grid or the electric systems of others to which the CAISO Controlled Grid is directly connected; (3) that, in the case of the Participating TO, is imminently likely (as determined in a non-discriminatory manner) to cause a material adverse effect on the security of, or damage to, the Participating TO's Transmission System, Participating TO's Interconnection Facilities, Distribution System, or the electric systems of others to which the Participating TO's electric system is directly connected; or (4) that, in the case of the Interconnection Customer, is imminently likely (as determined in a non-discriminatory manner) to cause a material adverse effect on the security of, or damage to, the Generating Facility or Interconnection Customer's Interconnection Facilities. System restoration and black start shall be considered Emergency Conditions; provided, that Interconnection Customer is not obligated by this LGIA to possess black start capability.

Environmental Law shall mean Applicable Laws or Regulations relating to pollution or protection of the environment or natural resources.

Federal Power Act shall mean the Federal Power Act, as amended, 16 U.S.C. §§ 791a et seq.

FERC shall mean the Federal Energy Regulatory Commission or its successor.

Force Majeure shall mean any act of God, labor disturbance, act of the public enemy, war, insurrection, riot, fire, storm or flood, explosion, breakage or accident to machinery or equipment, any order, regulation or restriction imposed by governmental, military or lawfully established civilian authorities, or any other cause beyond a Party's control. A Force Majeure event does not include acts of negligence or intentional wrongdoing by the Party claiming Force Majeure.

Generating Facility shall mean the Interconnection Customer's Electric Generating Unit(s) used for the production of electricity identified in the Interconnection Customer's Interconnection Request, but shall not include the Interconnection Customer's Interconnection Facilities.

Generating Facility Capacity shall mean the net capacity of the Generating

Facility and the aggregate net capacity of the Generating Facility where it includes multiple energy production devices.

Good Utility Practice shall mean any of the practices, methods and acts engaged in or approved by a significant portion of the electric utility industry during the relevant time period, or any of the practices, methods and acts which, in the exercise of reasonable judgment in light of the facts known at the time the decision was made, could have been expected to accomplish the desired result at a reasonable cost consistent with good business practices, reliability, safety and expedition. Good Utility Practice is not intended to be any one of a number of the optimum practices, methods, or acts to the exclusion of all others, but rather to be acceptable practices, methods, or acts generally accepted in the region.

Governmental Authority shall mean any federal, state, local or other governmental, regulatory or administrative agency, court, commission, department, board, or other governmental subdivision, legislature, rulemaking board, tribunal, or other governmental authority having jurisdiction over the Parties, their respective facilities, or the respective services they provide, and exercising or entitled to exercise any administrative, executive, police, or taxing authority or power; provided, however, that such term does not include the Interconnection Customer, CAISO, Participating TO, or any Affiliate thereof.

Hazardous Substances shall mean any chemicals, materials or substances defined as or included in the definition of “hazardous substances,” “hazardous wastes,” “hazardous materials,” “hazardous constituents,” “restricted hazardous materials,” “extremely hazardous substances,” “toxic substances,” “radioactive substances,” “contaminants,” “pollutants,” “toxic pollutants” or words of similar meaning and regulatory effect under any applicable Environmental Law, or any other chemical, material or substance, exposure to which is prohibited, limited or regulated by any applicable Environmental Law.

Initial Synchronization Date shall mean the date upon which an Electric Generating Unit is initially synchronized and upon which Trial Operation begins.

In-Service Date shall mean the date upon which the Interconnection Customer reasonably expects it will be ready to begin use of the Participating TO’s Interconnection Facilities to obtain back feed power.

Interconnection Customer's Interconnection Facilities shall mean all facilities and equipment, as identified in Appendix A of this LGIA, that are located between the Generating Facility and the Point of Change of Ownership, including any modification, addition, or upgrades to such facilities and equipment necessary to physically and electrically interconnect the Generating Facility to the Participating TO’s Transmission System. Interconnection Customer's Interconnection Facilities are sole use facilities.

Interconnection Facilities shall mean the Participating TO's Interconnection Facilities and the Interconnection Customer's Interconnection Facilities. Collectively, Interconnection Facilities include all facilities and equipment between the Generating Facility and the Point of Interconnection, including any modification, additions or upgrades that are necessary to physically and electrically interconnect the Generating Facility to the Participating TO's Transmission System. Interconnection Facilities are sole use facilities and shall not include Distribution Upgrades, Stand Alone Network Upgrades or Network Upgrades.

Interconnection Financial Security shall have the meaning assigned to it in Section 1.2 of the LGIP.

Interconnection Handbook shall mean a handbook, developed by the Participating TO and posted on the Participating TO's web site or otherwise made available by the Participating TO, describing technical and operational requirements for wholesale generators and loads connected to the Participating TO's portion of the CAISO Controlled Grid, as such handbook may be modified or superseded from time to time. Participating TO's standards contained in the Interconnection Handbook shall be deemed consistent with Good Utility Practice and Applicable Reliability Standards. In the event of a conflict between the terms of this LGIA and the terms of the Participating TO's Interconnection Handbook, the terms in this LGIA shall apply.

Interconnection Request shall mean a request, in the form of Appendix 1 to the Large Generator Interconnection Procedures, in accordance with the CAISO Tariff.

Interconnection Service shall mean the service provided by the Participating TO and CAISO associated with interconnecting the Interconnection Customer's Generating Facility to the Participating TO's Transmission System and enabling the CAISO Controlled Grid to receive electric energy and capacity from the Generating Facility at the Point of Interconnection, pursuant to the terms of this LGIA, the Participating TO's Transmission Owner Tariff, and the CAISO Tariff.

Interconnection Study shall mean either of the following studies: the Phase I Interconnection Study or the Phase II Interconnection Study conducted or caused to be performed by the CAISO, in coordination with the applicable Participating TO(s), pursuant to the Large Generator Interconnection Procedures.

IRS shall mean the Internal Revenue Service.

Large Generating Facility shall mean a Generating Facility having a Generating Facility Capacity of more than 20 MW.

Large Generator Interconnection Procedures (LGIP) shall mean the CAISO protocol that sets forth the interconnection procedures applicable to an Interconnection Request pertaining to a Large Generating Facility that is included in CAISO Tariff Appendix Y.

Large Generator Interconnection Study Process Agreement shall mean the agreement between the Interconnection Customer and the CAISO for the conduct of the Interconnection Studies.

Loss shall mean any and all damages, losses, and claims, including claims and actions relating to injury to or death of any person or damage to property, demand, suits, recoveries, costs and expenses, court costs, attorney fees, and all other obligations by or to third parties.

Material Modification shall mean those modifications that have a material impact on the cost or timing of any Interconnection Request or any other valid interconnection request with a later queue priority date.

Metering Equipment shall mean all metering equipment installed or to be installed for measuring the output of the Generating Facility pursuant to this LGIA at the metering points, including but not limited to instrument transformers, MWh-meters, data acquisition equipment, transducers, remote terminal unit, communications equipment, phone lines, and fiber optics.

NERC shall mean the North American Electric Reliability Council or its successor organization.

Network Upgrades shall be Participating TO's Delivery Network Upgrades and Participating TO's Reliability Network Upgrades.

Operational Control shall mean the rights of the CAISO under the Transmission Control Agreement and the CAISO Tariff to direct the parties to the Transmission Control Agreement how to operate their transmission lines and facilities and other electric plant affecting the reliability of those lines and facilities for the purpose of affording comparable non-discriminatory transmission access and meeting applicable reliability criteria.

Participating TO's Delivery Network Upgrades shall mean the additions, modifications, and upgrades to the Participating TO's Transmission System at or beyond the Point of Interconnection, other than Reliability Network Upgrades, identified in the Interconnection Studies, as identified in Appendix A, to relieve constraints on the CAISO Controlled Grid.

Participating TO's Interconnection Facilities shall mean all facilities and equipment owned, controlled or operated by the Participating TO from the Point of Change of Ownership to the Point of Interconnection as identified in Appendix A to this LGIA, including any modifications, additions or upgrades to such facilities and equipment. Participating TO's Interconnection Facilities are sole use facilities and shall not include Distribution Upgrades, Stand Alone Network Upgrades or Network Upgrades.

Participating TO's Reliability Network Upgrades shall mean the additions, modifications, and upgrades to the Participating TO's Transmission System at or beyond the Point of Interconnection, identified in the Interconnection Studies, as identified in Appendix A, necessary to interconnect the Large Generating Facility safely and reliably to the Participating TO's Transmission System, which would not have been necessary but for the interconnection of the Large Generating Facility, including additions, modifications, and upgrades necessary to remedy short circuit or stability problems resulting from the interconnection of the Large Generating Facility to the Participating TO's Transmission System. Participating TO's Reliability Network Upgrades also include, consistent with Applicable Reliability Standards and Applicable Reliability Council practice, the Participating TO's facilities necessary to mitigate any adverse impact the Large Generating Facility's interconnection may have on a path's Applicable Reliability Council rating. Participating TO's Reliability Network Upgrades do not include any Participating TO's Delivery Network Upgrades.

Participating TO's Transmission System shall mean the facilities owned and operated by the Participating TO and that have been placed under the CAISO's Operational Control, which facilities form part of the CAISO Controlled Grid.

Party or Parties shall mean the Participating TO, CAISO, Interconnection Customer or the applicable combination of the above.

Phase I Interconnection Study shall mean the engineering study conducted or caused to be performed by the CAISO, in coordination with the applicable Participating TO(s), that evaluates the impact of the proposed interconnection on the safety and reliability of the Participating TO's Transmission System and, if applicable, an Affected System. The study shall identify and detail the system impacts that would result if the Generating Facility(ies) were interconnected without identified project modifications or system modifications, as provided in the On-Peak Deliverability Assessment (as defined in the CAISO Tariff), and other potential impacts, including but not limited to those identified in the Scoping Meeting as described in the Large Generator Interconnection Procedures. The study will also identify the approximate total costs, based on per unit costs, of mitigating these impacts, along with an equitable allocation of those costs to Interconnection Customers for their individual Generating Facilities.

Phase II Interconnection Study shall mean an engineering and operational study conducted or caused to be performed by the CAISO once per calendar year, in coordination with the applicable Participating TO(s), to determine the Point of Interconnection and a list of facilities (including the Participating TO's Interconnection Facilities, Network Upgrades, Distribution Upgrades, and Stand Alone Network Upgrades), the cost of those facilities, and the time required to interconnect the Generating Facility(ies) with the Participating TO's Transmission System.

Point of Change of Ownership shall mean the point, as set forth in Appendix A to this LGIA, where the Interconnection Customer's Interconnection Facilities connect to the Participating TO's Interconnection Facilities.

Point of Interconnection shall mean the point, as set forth in Appendix A to this LGIA, where the Interconnection Facilities connect to the Participating TO's Transmission System.

QF PGA shall mean a Qualifying Facility Participating Generator Agreement specifying the special provisions for the operating relationship between a Qualifying Facility and the CAISO, a pro forma version of which is set forth in Appendix B.3 of the CAISO Tariff.

Qualifying Facility shall mean a qualifying cogeneration facility or qualifying small power production facility, as defined in the Code of Federal Regulations, Title 18, Part 292 (18 C.F.R. §292).

Reasonable Efforts shall mean, with respect to an action required to be attempted or taken by a Party under this LGIA, efforts that are timely and consistent with Good Utility Practice and are otherwise substantially equivalent to those a Party would use to protect its own interests.

Scoping Meeting shall mean the meeting among representatives of the Interconnection Customer, the Participating TO(s), other Affected Systems, and the CAISO conducted for the purpose of discussing alternative interconnection options, to exchange information including any transmission data and earlier study evaluations that would be reasonably expected to impact such interconnection options, to analyze such information, and to determine the potential feasible Points of Interconnection.

Stand Alone Network Upgrades shall mean Network Upgrades that the Interconnection Customer may construct without affecting day-to-day operations of the CAISO Controlled Grid or Affected Systems during their construction. The Participating TO, the CAISO, and the Interconnection Customer must agree as to what constitutes Stand Alone Network Upgrades and identify them in Appendix A to this LGIA.

System Protection Facilities shall mean the equipment, including necessary protection signal communications equipment, that protects (1) the Participating TO's Transmission System, Participating TO's Interconnection Facilities, CAISO Controlled Grid, and Affected Systems from faults or other electrical disturbances occurring at the Generating Facility and (2) the Generating Facility from faults or other electrical system disturbances occurring on the CAISO Controlled Grid, Participating TO's Interconnection Facilities, and Affected Systems or on other delivery systems or other generating systems to which the CAISO Controlled Grid is directly connected.

Transmission Control Agreement shall mean CAISO FERC Electric Tariff No. 7.

Trial Operation shall mean the period during which the Interconnection Customer is engaged in on-site test operations and commissioning of an Electric Generating Unit prior to Commercial Operation.

ARTICLE 2. EFFECTIVE DATE, TERM AND TERMINATION

- 2.1 Effective Date.** This LGIA shall become effective upon execution by all Parties subject to acceptance by FERC (if applicable), or if filed unexecuted, upon the date specified by FERC. The CAISO and Participating TO shall promptly file this LGIA with FERC upon execution in accordance with Article 3.1, if required.
- 2.2 Term of Agreement.** Subject to the provisions of Article 2.3, this LGIA shall remain in effect for a period of thirty (30) years from the Effective Date and shall be automatically renewed for each successive one-year period thereafter.
- 2.3 Termination Procedures.**
- 2.3.1 Written Notice.** This LGIA may be terminated by the Interconnection Customer after giving the CAISO and the Participating TO ninety (90) Calendar Days advance written notice, or by the CAISO and the Participating TO notifying FERC after the Generating Facility permanently ceases Commercial Operation.
- 2.3.2 Default.** A Party may terminate this LGIA in accordance with Article 17.
- 2.3.3 Suspension of Work.** This LGIA may be deemed terminated in accordance with Article 5.16.
- 2.3.4** Notwithstanding Articles 2.3.1, 2.3.2, and 2.3.3, no termination shall become effective until the Parties have complied with all Applicable Laws and Regulations applicable to such termination, including the filing with FERC of a notice of termination of this LGIA (if applicable), which notice has been accepted for filing by FERC, and the Interconnection Customer has fulfilled its termination cost obligations under Article 2.4.
- 2.4 Termination Costs.** Immediately upon the other Parties' receipt of a notice of the termination of this LGIA pursuant to Article 2.3 above, the CAISO and the Participating TO will determine the total cost responsibility of the Interconnection Customer. If, as of the date of the other Parties' receipt of the notice of termination, the Interconnection Customer has not already paid its share of Network Upgrade costs, as set forth in Appendix G to this LGIA, the Participating TO will liquidate the Interconnection Customer's Interconnection Financial Security associated with its cost responsibility for Network Upgrades, in accordance with Section 9.4 of the LGIP. However, to the extent that the costs of the Participating TO's Network Upgrades have received Abandoned Plant Approval, the Interconnection Customer shall not be responsible for its share of those charges.

The Interconnection Customer will also be responsible for all costs incurred or irrevocably committed to be incurred in association with the construction of the

Participating TO's Interconnection Facilities (including any cancellation costs relating to orders or contracts for Interconnection Facilities and equipment) and other such expenses, including any Distribution Upgrades for which the Participating TO or CAISO has incurred expenses or has irrevocably committed to incur expenses and has not been reimbursed by the Interconnection Customer, as of the date of the other Parties' receipt of the notice of termination, subject to the limitations set forth in this Article 2.4. Nothing in this Article 2.4 shall limit the Parties' rights under Article 17. If, as of the date of the other Parties' receipt of the notice of termination, the Interconnection Customer has not already reimbursed the Participating TO and the CAISO for costs incurred to construct the Participating TO's Interconnection Facilities, the Participating TO will liquidate the Interconnection Customer's Interconnection Financial Security associated with the construction of the Participating TO's Interconnection Facilities, in accordance with Section 9.4 of the LGIP. If the amount of the Interconnection Financial Security liquidated by the Participating TO under this Article 2.4 is insufficient to compensate the CAISO and the Participating TO for actual costs associated with the construction of the Participating TO's Interconnection Facilities contemplated in this Article, any additional amounts will be the responsibility of the Interconnection Customer, subject to the provisions of Section 9.4 of the LGIP. Any such additional amounts due from the Interconnection Customer beyond the amounts covered by its Interconnection Financial Security will be due to the Participating TO immediately upon termination of this LGIA in accordance with Section 9.4 of the LGIP.

If the amount of the Interconnection Financial Security exceeds the Interconnection Customer's cost responsibility under Section 9.4 of the LGIP, any excess amount will be released to the Interconnection Customer in accordance with Section 9.4 of the LGIP.

2.4.1 Notwithstanding the foregoing, in the event of termination by a Party, all Parties shall use commercially Reasonable Efforts to mitigate the costs, damages and charges arising as a consequence of termination. With respect to any portion of the Participating TO's Interconnection Facilities that have not yet been constructed or installed, the Participating TO shall to the extent possible and with the Interconnection Customer's authorization cancel any pending orders of, or return, any materials or equipment for, or contracts for construction of, such facilities; provided that in the event the Interconnection Customer elects not to authorize such cancellation, the Interconnection Customer shall assume all payment obligations with respect to such materials, equipment, and contracts, and the Participating TO shall deliver such material and equipment, and, if necessary, assign such contracts, to the Interconnection Customer as soon as practicable, at the Interconnection Customer's expense. To the extent that the Interconnection Customer has already paid the Participating TO for any or all such costs of materials or equipment not taken by the Interconnection Customer, the Participating TO shall

promptly refund such amounts to the Interconnection Customer, less any costs, including penalties, incurred by the Participating TO to cancel any pending orders of or return such materials, equipment, or contracts.

2.4.2 The Participating TO may, at its option, retain any portion of such materials, equipment, or facilities that the Interconnection Customer chooses not to accept delivery of, in which case the Participating TO shall be responsible for all costs associated with procuring such materials, equipment, or facilities.

2.4.3 With respect to any portion of the Interconnection Facilities, and any other facilities already installed or constructed pursuant to the terms of this LGIA, Interconnection Customer shall be responsible for all costs associated with the removal, relocation or other disposition or retirement of such materials, equipment, or facilities.

2.5 Disconnection. Upon termination of this LGIA, the Parties will take all appropriate steps to disconnect the Large Generating Facility from the Participating TO's Transmission System. All costs required to effectuate such disconnection shall be borne by the terminating Party, unless such termination resulted from the non-terminating Party's Default of this LGIA or such non-terminating Party otherwise is responsible for these costs under this LGIA.

2.6 Survival. This LGIA shall continue in effect after termination to the extent necessary to provide for final billings and payments and for costs incurred hereunder, including billings and payments pursuant to this LGIA; to permit the determination and enforcement of liability and indemnification obligations arising from acts or events that occurred while this LGIA was in effect; and to permit each Party to have access to the lands of the other Parties pursuant to this LGIA or other applicable agreements, to disconnect, remove or salvage its own facilities and equipment.

ARTICLE 3. REGULATORY FILINGS AND CAISO TARIFF COMPLIANCE

3.1 Filing. The Participating TO and the CAISO shall file this LGIA (and any amendment hereto) with the appropriate Governmental Authority(ies), if required. The Interconnection Customer may request that any information so provided be subject to the confidentiality provisions of Article 22. If the Interconnection Customer has executed this LGIA, or any amendment thereto, the Interconnection Customer shall reasonably cooperate with the Participating TO and CAISO with respect to such filing and to provide any information reasonably requested by the Participating TO or CAISO needed to comply with applicable regulatory requirements.

3.2 Agreement Subject to CAISO Tariff. The Interconnection Customer will comply with all applicable provisions of the CAISO Tariff, including the LGIP.

- 3.3 Relationship Between this LGIA and the CAISO Tariff.** With regard to rights and obligations between the Participating TO and the Interconnection Customer, if and to the extent a matter is specifically addressed by a provision of this LGIA (including any appendices, schedules or other attachments to this LGIA), the provisions of this LGIA shall govern. If and to the extent a provision of this LGIA is inconsistent with the CAISO Tariff and dictates rights and obligations between the CAISO and the Participating TO or the CAISO and the Interconnection Customer, the CAISO Tariff shall govern.
- 3.4 Relationship Between this LGIA and the QF PGA.** With regard to the rights and obligations of a Qualifying Facility that has entered into a QF PGA with the CAISO and has entered into this LGIA, if and to the extent a matter is specifically addressed by a provision of the QF PGA that is inconsistent with this LGIA, the terms of the QF PGA shall govern.

ARTICLE 4. SCOPE OF SERVICE

- 4.1 Interconnection Service.** Interconnection Service allows the Interconnection Customer to connect the Large Generating Facility to the Participating TO's Transmission System and be eligible to deliver the Large Generating Facility's output using the available capacity of the CAISO Controlled Grid. To the extent the Interconnection Customer wants to receive Interconnection Service, the Participating TO shall construct facilities identified in Appendices A and C that the Participating TO is responsible to construct.

Interconnection Service does not necessarily provide the Interconnection Customer with the capability to physically deliver the output of its Large Generating Facility to any particular load on the CAISO Controlled Grid without incurring congestion costs. In the event of transmission constraints on the CAISO Controlled Grid, the Interconnection Customer's Large Generating Facility shall be subject to the applicable congestion management procedures in the CAISO Tariff in the same manner as all other resources.

- 4.2 Provision of Service.** The Participating TO and the CAISO shall provide Interconnection Service for the Large Generating Facility.
- 4.3 Performance Standards.** Each Party shall perform all of its obligations under this LGIA in accordance with Applicable Laws and Regulations, Applicable Reliability Standards, and Good Utility Practice, and to the extent a Party is required or prevented or limited in taking any action by such regulations and standards, such Party shall not be deemed to be in Breach of this LGIA for its compliance therewith. If such Party is the CAISO or Participating TO, then that Party shall amend the LGIA and submit the amendment to FERC for approval.

- 4.4 No Transmission Service.** The execution of this LGIA does not constitute a request for, nor the provision of, any transmission service under the CAISO Tariff, and does not convey any right to deliver electricity to any specific customer or point of delivery.
- 4.5 Interconnection Customer Provided Services.** The services provided by Interconnection Customer under this LGIA are set forth in Article 9.6 and Article 13.5.1. Interconnection Customer shall be paid for such services in accordance with Article 11.6.

ARTICLE 5. INTERCONNECTION FACILITIES ENGINEERING, PROCUREMENT, AND CONSTRUCTION

Interconnection Facilities, Network Upgrades, and Distribution Upgrades shall be studied, designed, and constructed pursuant to Good Utility Practice. Such studies, design and construction shall be based on the assumed accuracy and completeness of all technical information received by the Participating TO and the CAISO from the Interconnection Customer associated with interconnecting the Large Generating Facility.

- 5.1 Options.** Unless otherwise mutually agreed among the Parties, the Interconnection Customer shall select the In-Service Date, Initial Synchronization Date, and Commercial Operation Date; and either Standard Option or Alternate Option set forth below for completion of the Participating TO's Interconnection Facilities and Network Upgrades as set forth in Appendix A, Interconnection Facilities, Network Upgrades, and Distribution Upgrades, and such dates and selected option shall be set forth in Appendix B, Milestones.

- 5.1.1 Standard Option.** The Participating TO shall design, procure, and construct the Participating TO's Interconnection Facilities, Network Upgrades, and Distribution Upgrades, using Reasonable Efforts to complete the Participating TO's Interconnection Facilities, Network Upgrades, and Distribution Upgrades by the dates set forth in Appendix B, Milestones. The Participating TO shall not be required to undertake any action which is inconsistent with its standard safety practices, its material and equipment specifications, its design criteria and construction procedures, its labor agreements, and Applicable Laws and Regulations. In the event the Participating TO reasonably expects that it will not be able to complete the Participating TO's Interconnection Facilities, Network Upgrades, and Distribution Upgrades by the specified dates, the Participating TO shall promptly provide written notice to the Interconnection Customer and the CAISO and shall undertake Reasonable Efforts to meet the earliest dates thereafter.

5.1.2 Alternate Option. If the dates designated by the Interconnection Customer are acceptable to the Participating TO, the Participating TO shall so notify the Interconnection Customer within thirty (30) Calendar Days, and shall assume responsibility for the design, procurement and construction of the Participating TO's Interconnection Facilities by the designated dates.

If the Participating TO subsequently fails to complete the Participating TO's Interconnection Facilities by the In-Service Date, to the extent necessary to provide back feed power; or fails to complete Network Upgrades by the Initial Synchronization Date to the extent necessary to allow for Trial Operation at full power output, unless other arrangements are made by the Parties for such Trial Operation; or fails to complete the Network Upgrades by the Commercial Operation Date, as such dates are reflected in Appendix B, Milestones; the Participating TO shall pay the Interconnection Customer liquidated damages in accordance with Article 5.3, Liquidated Damages, provided, however, the dates designated by the Interconnection Customer shall be extended day for day for each day that the CAISO refuses to grant clearances to install equipment.

5.1.3 Option to Build. If the dates designated by the Interconnection Customer are not acceptable to the Participating TO, the Participating TO shall so notify the Interconnection Customer within thirty (30) Calendar Days, and unless the Parties agree otherwise, the Interconnection Customer shall have the option to assume responsibility for the design, procurement and construction of the Participating TO's Interconnection Facilities and Stand Alone Network Upgrades. If the Interconnection Customer elects to exercise its option to assume responsibility for the design, procurement and construction of the Participating TO's Interconnection Facilities and Stand Alone Network Upgrades, it shall so notify the Participating TO within thirty (30) Calendar Days of receipt of the Participating TO's notification that the designated dates are not acceptable to the Participating TO. The Participating TO, CAISO, and Interconnection Customer must agree as to what constitutes Stand Alone Network Upgrades and identify such Stand Alone Network Upgrades in Appendix A to this LGIA. Except for Stand Alone Network Upgrades, the Interconnection Customer shall have no right to construct Network Upgrades under this option.

5.1.4 Negotiated Option. If the Interconnection Customer elects not to exercise its option under Article 5.1.3, Option to Build, the Interconnection Customer shall so notify the Participating TO within thirty (30) Calendar Days of receipt of the Participating TO's notification that the designated dates are not acceptable to the Participating TO, and the Parties shall in good faith attempt to negotiate terms and conditions (including revision of the specified dates and liquidated damages, the provision of incentives or

the procurement and construction of a portion of the Participating TO's Interconnection Facilities and Stand Alone Network Upgrades by the Interconnection Customer) pursuant to which the Participating TO is responsible for the design, procurement and construction of the Participating TO's Interconnection Facilities and Network Upgrades. If the Parties are unable to reach agreement on such terms and conditions, the Participating TO shall assume responsibility for the design, procurement and construction of the Participating TO's Interconnection Facilities and Network Upgrades pursuant to Article 5.1.1, Standard Option.

5.2 General Conditions Applicable to Option to Build. If the Interconnection Customer assumes responsibility for the design, procurement and construction of the Participating TO's Interconnection Facilities and Stand Alone Network Upgrades,

(1) the Interconnection Customer shall engineer, procure equipment, and construct the Participating TO's Interconnection Facilities and Stand Alone Network Upgrades (or portions thereof) using Good Utility Practice and using standards and specifications provided in advance by the Participating TO;

(2) The Interconnection Customer's engineering, procurement and construction of the Participating TO's Interconnection Facilities and Stand Alone Network Upgrades shall comply with all requirements of law to which the Participating TO would be subject in the engineering, procurement or construction of the Participating TO's Interconnection Facilities and Stand Alone Network Upgrades;

(3) the Participating TO shall review, and the Interconnection Customer shall obtain the Participating TO's approval of, the engineering design, equipment acceptance tests, and the construction of the Participating TO's Interconnection Facilities and Stand Alone Network Upgrades, which approval shall not be unreasonably withheld, and the CAISO may, at its option, review the engineering design, equipment acceptance tests, and the construction of the Participating TO's Interconnection Facilities and Stand Alone Network Upgrades;

(4) prior to commencement of construction, the Interconnection Customer shall provide to the Participating TO, with a copy to the CAISO for informational purposes, a schedule for construction of the Participating TO's Interconnection Facilities and Stand Alone Network Upgrades, and shall promptly respond to requests for information from the Participating TO;

(5) at any time during construction, the Participating TO shall have the right to gain unrestricted access to the Participating TO's Interconnection

Facilities and Stand Alone Network Upgrades and to conduct inspections of the same;

(6) at any time during construction, should any phase of the engineering, equipment procurement, or construction of the Participating TO's Interconnection Facilities and Stand Alone Network Upgrades not meet the standards and specifications provided by the Participating TO, the Interconnection Customer shall be obligated to remedy deficiencies in that portion of the Participating TO's Interconnection Facilities and Stand Alone Network Upgrades;

(7) the Interconnection Customer shall indemnify the CAISO and Participating TO for claims arising from the Interconnection Customer's construction of the Participating TO's Interconnection Facilities and Stand Alone Network Upgrades under the terms and procedures applicable to Article 18.1 Indemnity;

(8) The Interconnection Customer shall transfer control of the Participating TO's Interconnection Facilities to the Participating TO and shall transfer Operational Control of Stand Alone Network Upgrades to the CAISO;

(9) Unless the Parties otherwise agree, the Interconnection Customer shall transfer ownership of the Participating TO's Interconnection Facilities and Stand Alone Network Upgrades to the Participating TO. As soon as reasonably practicable, but within twelve months after completion of the construction of the Participating TO's Interconnection Facilities and Stand Alone Network Upgrades, the Interconnection Customer shall provide an invoice of the final cost of the construction of the Participating TO's Interconnection Facilities and Stand Alone Network Upgrades to the Participating TO, which invoice shall set forth such costs in sufficient detail to enable the Participating TO to reflect the proper costs of such facilities in its transmission rate base and to identify the investment upon which refunds will be provided;

(10) the Participating TO shall accept for operation and maintenance the Participating TO's Interconnection Facilities and Stand Alone Network Upgrades to the extent engineered, procured, and constructed in accordance with this Article 5.2; and

(11) The Interconnection Customer's engineering, procurement and construction of the Participating TO's Interconnection Facilities and Stand Alone Network Upgrades shall comply with all requirements of the "Option to Build" conditions set forth in Appendix C. Interconnection Customer shall deliver to the Participating TO "as-built" drawings, information, and any other documents that are reasonably required by the Participating TO to assure that the Interconnection Facilities and Stand-Alone Network

Upgrades are built to the standards and specifications required by the Participating TO.

5.3 Liquidated Damages. The actual damages to the Interconnection Customer, in the event the Participating TO's Interconnection Facilities or Network Upgrades are not completed by the dates designated by the Interconnection Customer and accepted by the Participating TO pursuant to subparagraphs 5.1.2 or 5.1.4, above, may include Interconnection Customer's fixed operation and maintenance costs and lost opportunity costs. Such actual damages are uncertain and impossible to determine at this time. Because of such uncertainty, any liquidated damages paid by the Participating TO to the Interconnection Customer in the event that the Participating TO does not complete any portion of the Participating TO's Interconnection Facilities or Network Upgrades by the applicable dates, shall be an amount equal to $\frac{1}{2}$ of 1 percent per day of the actual cost of the Participating TO's Interconnection Facilities and Network Upgrades, in the aggregate, for which the Participating TO has assumed responsibility to design, procure and construct.

However, in no event shall the total liquidated damages exceed 20 percent of the actual cost of the Participating TO's Interconnection Facilities and Network Upgrades for which the Participating TO has assumed responsibility to design, procure, and construct. The foregoing payments will be made by the Participating TO to the Interconnection Customer as just compensation for the damages caused to the Interconnection Customer, which actual damages are uncertain and impossible to determine at this time, and as reasonable liquidated damages, but not as a penalty or a method to secure performance of this LGIA. Liquidated damages, when the Parties agree to them, are the exclusive remedy for the Participating TO's failure to meet its schedule.

No liquidated damages shall be paid to the Interconnection Customer if: (1) the Interconnection Customer is not ready to commence use of the Participating TO's Interconnection Facilities or Network Upgrades to take the delivery of power for the Electric Generating Unit's Trial Operation or to export power from the Electric Generating Unit on the specified dates, unless the Interconnection Customer would have been able to commence use of the Participating TO's Interconnection Facilities or Network Upgrades to take the delivery of power for Electric Generating Unit's Trial Operation or to export power from the Electric Generating Unit, but for the Participating TO's delay; (2) the Participating TO's failure to meet the specified dates is the result of the action or inaction of the Interconnection Customer or any other interconnection customer who has entered into an interconnection agreement with the CAISO and/or Participating TO, action or inaction by the CAISO, or any cause beyond the Participating TO's reasonable control or reasonable ability to cure; (3) the Interconnection Customer has assumed responsibility for the design, procurement and construction of the Participating TO's Interconnection Facilities and Stand Alone Network Upgrades; or (4) the Parties have otherwise agreed.

In no event shall the CAISO have any responsibility or liability to the Interconnection Customer for liquidated damages pursuant to the provisions of this Article 5.3.

5.4 Power System Stabilizers. The Interconnection Customer shall procure, install, maintain and operate Power System Stabilizers in accordance with Applicable Reliability Standards, the guidelines and procedures established by the Applicable Reliability Council, and the provisions of Section 4.6.5.1 of the CAISO Tariff. The CAISO reserves the right to establish reasonable minimum acceptable settings for any installed Power System Stabilizers, subject to the design and operating limitations of the Large Generating Facility. If the Large Generating Facility's Power System Stabilizers are removed from service or not capable of automatic operation, the Interconnection Customer shall immediately notify the CAISO and the Participating TO and restore the Power System Stabilizers to operation as soon as possible. The CAISO shall have the right to order the reduction in output or disconnection of the Large Generating Facility if the reliability of the CAISO Controlled Grid would be adversely affected as a result of improperly tuned Power System Stabilizers. The requirements of this Article 5.4 shall apply to Asynchronous Generating Facilities in accordance with Appendix H.

5.5 Equipment Procurement. If responsibility for construction of the Participating TO's Interconnection Facilities or Network Upgrades is to be borne by the Participating TO, then the Participating TO shall commence design of the Participating TO's Interconnection Facilities or Network Upgrades and procure necessary equipment as soon as practicable after all of the following conditions are satisfied, unless the Parties otherwise agree in writing:

5.5.1 The CAISO, in coordination with the applicable Participating TO(s), has completed the Phase II Interconnection Study pursuant to the Large Generator Interconnection Facilities Study Process Agreement;

5.5.2 The Participating TO has received written authorization to proceed with design and procurement from the Interconnection Customer by the date specified in Appendix B, Milestones; and

5.5.3 The Interconnection Customer has provided security to the Participating TO in accordance with Article 11.5 by the dates specified in Appendix B, Milestones.

5.6 Construction Commencement. The Participating TO shall commence construction of the Participating TO's Interconnection Facilities and Network Upgrades for which it is responsible as soon as practicable after the following additional conditions are satisfied:

- 5.6.1** Approval of the appropriate Governmental Authority has been obtained for any facilities requiring regulatory approval;
- 5.6.2** Necessary real property rights and rights-of-way have been obtained, to the extent required for the construction of a discrete aspect of the Participating TO's Interconnection Facilities and Network Upgrades;
- 5.6.3** The Participating TO has received written authorization to proceed with construction from the Interconnection Customer by the date specified in Appendix B, Milestones; and
- 5.6.4** The Interconnection Customer has provided payment and security to the Participating TO in accordance with Article 11.5 by the dates specified in Appendix B, Milestones.
- 5.7 Work Progress.** The Parties will keep each other advised periodically as to the progress of their respective design, procurement and construction efforts. Any Party may, at any time, request a progress report from another Party. If, at any time, the Interconnection Customer determines that the completion of the Participating TO's Interconnection Facilities will not be required until after the specified In-Service Date, the Interconnection Customer will provide written notice to the Participating TO and CAISO of such later date upon which the completion of the Participating TO's Interconnection Facilities will be required.
- 5.8 Information Exchange.** As soon as reasonably practicable after the Effective Date, the Parties shall exchange information regarding the design and compatibility of the Interconnection Customer's Interconnection Facilities and Participating TO's Interconnection Facilities and compatibility of the Interconnection Facilities with the Participating TO's Transmission System, and shall work diligently and in good faith to make any necessary design changes.
- 5.9 Limited Operation.** If any of the Participating TO's Interconnection Facilities or Network Upgrades are not reasonably expected to be completed prior to the Commercial Operation Date of the Electric Generating Unit, the Participating TO and/or CAISO, as applicable, shall, upon the request and at the expense of the Interconnection Customer, perform operating studies on a timely basis to determine the extent to which the Electric Generating Unit and the Interconnection Customer's Interconnection Facilities may operate prior to the completion of the Participating TO's Interconnection Facilities or Network Upgrades consistent with Applicable Laws and Regulations, Applicable Reliability Standards, Good Utility Practice, and this LGIA. The Participating TO and CAISO shall permit Interconnection Customer to operate the Electric Generating Unit and the Interconnection Customer's Interconnection Facilities in accordance with the results of such studies.

5.10 Interconnection Customer's Interconnection Facilities. The Interconnection Customer shall, at its expense, design, procure, construct, own and install the Interconnection Customer's Interconnection Facilities, as set forth in Appendix A.

5.10.1 Large Generating Facility and Interconnection Customer's Interconnection Facilities Specifications. In addition to the Interconnection Customer's responsibility to submit technical data with its Interconnection Request as required by Section 3.5.1 of the LGIP, the Interconnection Customer shall submit all remaining necessary specifications for the Interconnection Customer's Interconnection Facilities and Large Generating Facility, including System Protection Facilities, to the Participating TO and the CAISO at least one hundred eighty (180) Calendar Days prior to the Initial Synchronization Date; and final specifications for review and comment at least ninety (90) Calendar Days prior to the Initial Synchronization Date. The Participating TO and the CAISO shall review such specifications pursuant to this LGIA and the LGIP to ensure that the Interconnection Customer's Interconnection Facilities and Large Generating Facility are compatible with the technical specifications, operational control, safety requirements, and any other applicable requirements of the Participating TO and the CAISO and comment on such specifications within thirty (30) Calendar Days of the Interconnection Customer's submission. All specifications provided hereunder shall be deemed confidential.

5.10.2 Participating TO's and CAISO's Review. The Participating TO's and the CAISO's review of the Interconnection Customer's final specifications shall not be construed as confirming, endorsing, or providing a warranty as to the design, fitness, safety, durability or reliability of the Large Generating Facility, or the Interconnection Customer's Interconnection Facilities. Interconnection Customer shall make such changes to the Interconnection Customer's Interconnection Facilities as may reasonably be required by the Participating TO or the CAISO, in accordance with Good Utility Practice, to ensure that the Interconnection Customer's Interconnection Facilities are compatible with the technical specifications, Operational Control, and safety requirements of the Participating TO or the CAISO.

5.10.3 Interconnection Customer's Interconnection Facilities Construction. The Interconnection Customer's Interconnection Facilities shall be designed and constructed in accordance with Good Utility Practice. Within one hundred twenty (120) Calendar Days after the Commercial Operation Date, unless the Participating TO and Interconnection Customer agree on another mutually acceptable deadline, the Interconnection Customer shall deliver to the Participating TO and CAISO "as-built" drawings, information and documents for the Interconnection Customer's Interconnection Facilities and the Electric Generating Unit(s), such as: a one-line diagram, a site plan showing the Large Generating Facility and the Interconnection

Customer's Interconnection Facilities, plan and elevation drawings showing the layout of the Interconnection Customer's Interconnection Facilities, a relay functional diagram, relaying AC and DC schematic wiring diagrams and relay settings for all facilities associated with the Interconnection Customer's step-up transformers, the facilities connecting the Large Generating Facility to the step-up transformers and the Interconnection Customer's Interconnection Facilities, and the impedances (determined by factory tests) for the associated step-up transformers and the Electric Generating Units. The Interconnection Customer shall provide the Participating TO and the CAISO specifications for the excitation system, automatic voltage regulator, Large Generating Facility control and protection settings, transformer tap settings, and communications, if applicable. Any deviations from the relay settings, machine specifications, and other specifications originally submitted by the Interconnection Customer shall be assessed by the Participating TO and the CAISO pursuant to the appropriate provisions of this LGIA and the LGIP.

5.10.4 Interconnection Customer to Meet Requirements of the Participating TO's Interconnection Handbook. The Interconnection Customer shall comply with the Participating TO's Interconnection Handbook.

5.11 Participating TO's Interconnection Facilities Construction. The Participating TO's Interconnection Facilities shall be designed and constructed in accordance with Good Utility Practice. Upon request, within one hundred twenty (120) Calendar Days after the Commercial Operation Date, unless the Participating TO and Interconnection Customer agree on another mutually acceptable deadline, the Participating TO shall deliver to the Interconnection Customer and the CAISO the following "as-built" drawings, information and documents for the Participating TO's Interconnection Facilities. No as-built drawings will be provided.

The Participating TO will obtain control for operating and maintenance purposes of the Participating TO's Interconnection Facilities and Stand Alone Network Upgrades upon completion of such facilities. Pursuant to Article 5.2, the CAISO will obtain Operational Control of the Stand Alone Network Upgrades prior to the Commercial Operation Date.

5.12 Access Rights. Upon reasonable notice and supervision by a Party, and subject to any required or necessary regulatory approvals, a Party ("Granting Party") shall furnish at no cost to the other Party ("Access Party") any rights of use, licenses, rights of way and easements with respect to lands owned or controlled by the Granting Party, its agents (if allowed under the applicable agency agreement), or any Affiliate, that are necessary to enable the Access Party to obtain ingress and egress to construct, operate, maintain, repair, test (or witness testing), inspect, replace or remove facilities and equipment to: (i) interconnect the Large Generating Facility with the Participating TO's

Transmission System; (ii) operate and maintain the Large Generating Facility, the Interconnection Facilities and the Participating TO's Transmission System; and (iii) disconnect or remove the Access Party's facilities and equipment upon termination of this LGIA. In exercising such licenses, rights of way and easements, the Access Party shall not unreasonably disrupt or interfere with normal operation of the Granting Party's business and shall adhere to the safety rules and procedures established in advance, as may be changed from time to time, by the Granting Party and provided to the Access Party.

- 5.13 Lands of Other Property Owners.** If any part of the Participating TO's Interconnection Facilities and/or Network Upgrades are to be installed on property owned by persons other than the Interconnection Customer or Participating TO, the Participating TO shall at the Interconnection Customer's expense use efforts, similar in nature and extent to those that it typically undertakes on its own behalf or on behalf of its Affiliates, including use of its eminent domain authority, and to the extent consistent with state law, to procure from such persons any rights of use, licenses, rights of way and easements that are necessary to construct, operate, maintain, test, inspect, replace or remove the Participating TO's Interconnection Facilities and/or Network Upgrades upon such property.
- 5.14 Permits.** Participating TO and Interconnection Customer shall cooperate with each other in good faith in obtaining all permits, licenses and authorization that are necessary to accomplish the interconnection in compliance with Applicable Laws and Regulations. With respect to this paragraph, the Participating TO shall provide permitting assistance to the Interconnection Customer comparable to that provided to the Participating TO's own, or an Affiliate's generation.
- 5.15 Early Construction of Base Case Facilities.** The Interconnection Customer may request the Participating TO to construct, and the Participating TO shall construct, using Reasonable Efforts to accommodate Interconnection Customer's In-Service Date, all or any portion of any Network Upgrades required for Interconnection Customer to be interconnected to the Participating TO's Transmission System which are included in the Base Case of the Interconnection Studies for the Interconnection Customer, and which also are required to be constructed for another interconnection customer, but where such construction is not scheduled to be completed in time to achieve Interconnection Customer's In-Service Date.
- 5.16 Suspension.** The Interconnection Customer reserves the right, upon written notice to the Participating TO and the CAISO, to suspend at any time all work associated with the construction and installation of the Participating TO's Interconnection Facilities, Network Upgrades, and/or Distribution Upgrades required under this LGIA, other than Network Upgrades identified in the Phase II Interconnection Study as common to multiple Generating Facilities, with the condition that the Participating TO's electrical system and the CAISO Controlled

Grid shall be left in a safe and reliable condition in accordance with Good Utility Practice and the Participating TO's safety and reliability criteria and the CAISO's Applicable Reliability Standards. In such event, the Interconnection Customer shall be responsible for all reasonable and necessary costs which the Participating TO (i) has incurred pursuant to this LGIA prior to the suspension and (ii) incurs in suspending such work, including any costs incurred to perform such work as may be necessary to ensure the safety of persons and property and the integrity of the Participating TO's electric system during such suspension and, if applicable, any costs incurred in connection with the cancellation or suspension of material, equipment and labor contracts which the Participating TO cannot reasonably avoid; provided, however, that prior to canceling or suspending any such material, equipment or labor contract, the Participating TO shall obtain Interconnection Customer's authorization to do so.

The Participating TO shall invoice the Interconnection Customer for such costs pursuant to Article 12 and shall use due diligence to minimize its costs. In the event Interconnection Customer suspends work required under this LGIA pursuant to this Article 5.16, and has not requested the Participating TO to recommence the work or has not itself recommenced work required under this LGIA in time to ensure that the new projected Commercial Operation Date for the full Generating Facility Capacity of the Large Generating Facility is no more than three (3) years from the Commercial Operation Date identified in Appendix B hereto, this LGIA shall be deemed terminated and the Interconnection Customer's responsibility for costs will be determined in accordance with Section 2.4 of this LGIA. The suspension period shall begin on the date the suspension is requested, or the date of the written notice to the Participating TO and the CAISO, if no effective date is specified.

5.17 Taxes.

5.17.1 Interconnection Customer Payments Not Taxable. The Parties intend that all payments or property transfers made by the Interconnection Customer to the Participating TO for the installation of the Participating TO's Interconnection Facilities and the Network Upgrades shall be non-taxable, either as contributions to capital, or as a refundable advance, in accordance with the Internal Revenue Code and any applicable state income tax laws and shall not be taxable as contributions in aid of construction or otherwise under the Internal Revenue Code and any applicable state income tax laws.

5.17.2 Representations And Covenants. In accordance with IRS Notice 2001-82 and IRS Notice 88-129, the Interconnection Customer represents and covenants that (i) ownership of the electricity generated at the Large Generating Facility will pass to another party prior to the transmission of the electricity on the CAISO Controlled Grid, (ii) for income tax purposes, the amount of any payments and the cost of any property transferred to

the Participating TO for the Participating TO's Interconnection Facilities will be capitalized by the Interconnection Customer as an intangible asset and recovered using the straight-line method over a useful life of twenty (20) years, and (iii) any portion of the Participating TO's Interconnection Facilities that is a "dual-use intertie," within the meaning of IRS Notice 88-129, is reasonably expected to carry only a de minimis amount of electricity in the direction of the Large Generating Facility. For this purpose, "de minimis amount" means no more than 5 percent of the total power flows in both directions, calculated in accordance with the "5 percent test" set forth in IRS Notice 88-129. This is not intended to be an exclusive list of the relevant conditions that must be met to conform to IRS requirements for non-taxable treatment.

At the Participating TO's request, the Interconnection Customer shall provide the Participating TO with a report from an independent engineer confirming its representation in clause (iii), above. The Participating TO represents and covenants that the cost of the Participating TO's Interconnection Facilities paid for by the Interconnection Customer without the possibility of refund or credit will have no net effect on the base upon which rates are determined.

5.17.3 Indemnification for the Cost Consequence of Current Tax Liability Imposed Upon the Participating TO. Notwithstanding Article 5.17.1, the Interconnection Customer shall protect, indemnify and hold harmless the Participating TO from the cost consequences of any current tax liability imposed against the Participating TO as the result of payments or property transfers made by the Interconnection Customer to the Participating TO under this LGIA for Interconnection Facilities, as well as any interest and penalties, other than interest and penalties attributable to any delay caused by the Participating TO.

The Participating TO shall not include a gross-up for the cost consequences of any current tax liability in the amounts it charges the Interconnection Customer under this LGIA unless (i) the Participating TO has determined, in good faith, that the payments or property transfers made by the Interconnection Customer to the Participating TO should be reported as income subject to taxation or (ii) any Governmental Authority directs the Participating TO to report payments or property as income subject to taxation; provided, however, that the Participating TO may require the Interconnection Customer to provide security for Interconnection Facilities, in a form reasonably acceptable to the Participating TO (such as a parental guarantee or a letter of credit), in an amount equal to the cost consequences of any current tax liability under this Article 5.17. The Interconnection Customer shall reimburse the Participating TO for such costs on a fully grossed-up basis, in accordance with Article 5.17.4, within thirty (30) Calendar Days of receiving written

notification from the Participating TO of the amount due, including detail about how the amount was calculated.

The indemnification obligation shall terminate at the earlier of (1) the expiration of the ten year testing period and the applicable statute of limitation, as it may be extended by the Participating TO upon request of the IRS, to keep these years open for audit or adjustment, or (2) the occurrence of a subsequent taxable event and the payment of any related indemnification obligations as contemplated by this Article 5.17.

5.17.4 Tax Gross-Up Amount. The Interconnection Customer's liability for the cost consequences of any current tax liability under this Article 5.17 shall be calculated on a fully grossed-up basis. Except as may otherwise be agreed to by the parties, this means that the Interconnection Customer will pay the Participating TO, in addition to the amount paid for the Interconnection Facilities and Network Upgrades, an amount equal to (1) the current taxes imposed on the Participating TO ("Current Taxes") on the excess of (a) the gross income realized by the Participating TO as a result of payments or property transfers made by the Interconnection Customer to the Participating TO under this LGIA (without regard to any payments under this Article 5.17) (the "Gross Income Amount") over (b) the present value of future tax deductions for depreciation that will be available as a result of such payments or property transfers (the "Present Value Depreciation Amount"), plus (2) an additional amount sufficient to permit the Participating TO to receive and retain, after the payment of all Current Taxes, an amount equal to the net amount described in clause (1).

For this purpose, (i) Current Taxes shall be computed based on the Participating TO's composite federal and state tax rates at the time the payments or property transfers are received and the Participating TO will be treated as being subject to tax at the highest marginal rates in effect at that time (the "Current Tax Rate"), and (ii) the Present Value Depreciation Amount shall be computed by discounting the Participating TO's anticipated tax depreciation deductions as a result of such payments or property transfers by the Participating TO's current weighted average cost of capital. Thus, the formula for calculating the Interconnection Customer's liability to the Participating TO pursuant to this Article 5.17.4 can be expressed as follows: $(\text{Current Tax Rate} \times (\text{Gross Income Amount} - \text{Present Value of Tax Depreciation})) / (1 - \text{Current Tax Rate})$. Interconnection Customer's estimated tax liability in the event taxes are imposed shall be stated in Appendix A, Interconnection Facilities, Network Upgrades and Distribution Upgrades.

5.17.5 Private Letter Ruling or Change or Clarification of Law. At the Interconnection Customer's request and expense, the Participating TO shall file with the IRS a request for a private letter ruling as to whether any property transferred or sums paid, or to be paid, by the Interconnection Customer to the Participating TO under this LGIA are subject to federal income taxation. The Interconnection Customer will prepare the initial draft of the request for a private letter ruling, and will certify under penalties of perjury that all facts represented in such request are true and accurate to the best of the Interconnection Customer's knowledge. The Participating TO and Interconnection Customer shall cooperate in good faith with respect to the submission of such request, provided, however, the Interconnection Customer and the Participating TO explicitly acknowledge (and nothing herein is intended to alter) Participating TO's obligation under law to certify that the facts presented in the ruling request are true, correct and complete.

The Participating TO shall keep the Interconnection Customer fully informed of the status of such request for a private letter ruling and shall execute either a privacy act waiver or a limited power of attorney, in a form acceptable to the IRS, that authorizes the Interconnection Customer to participate in all discussions with the IRS regarding such request for a private letter ruling. The Participating TO shall allow the Interconnection Customer to attend all meetings with IRS officials about the request and shall permit the Interconnection Customer to prepare the initial drafts of any follow-up letters in connection with the request.

5.17.6 Subsequent Taxable Events. If, within 10 years from the date on which the relevant Participating TO's Interconnection Facilities are placed in service, (i) the Interconnection Customer Breaches the covenants contained in Article 5.17.2, (ii) a "disqualification event" occurs within the meaning of IRS Notice 88-129, or (iii) this LGIA terminates and the Participating TO retains ownership of the Interconnection Facilities and Network Upgrades, the Interconnection Customer shall pay a tax gross-up for the cost consequences of any current tax liability imposed on the Participating TO, calculated using the methodology described in Article 5.17.4 and in accordance with IRS Notice 90-60.

5.17.7 Contests. In the event any Governmental Authority determines that the Participating TO's receipt of payments or property constitutes income that is subject to taxation, the Participating TO shall notify the Interconnection Customer, in writing, within thirty (30) Calendar Days of receiving notification of such determination by a Governmental Authority. Upon the timely written request by the Interconnection Customer and at the Interconnection Customer's sole expense, the Participating TO may appeal, protest, seek abatement of, or otherwise oppose such determination. Upon the Interconnection Customer's written request and

sole expense, the Participating TO may file a claim for refund with respect to any taxes paid under this Article 5.17, whether or not it has received such a determination. The Participating TO reserve the right to make all decisions with regard to the prosecution of such appeal, protest, abatement or other contest, including the selection of counsel and compromise or settlement of the claim, but the Participating TO shall keep the Interconnection Customer informed, shall consider in good faith suggestions from the Interconnection Customer about the conduct of the contest, and shall reasonably permit the Interconnection Customer or an Interconnection Customer representative to attend contest proceedings.

The Interconnection Customer shall pay to the Participating TO on a periodic basis, as invoiced by the Participating TO, the Participating TO's documented reasonable costs of prosecuting such appeal, protest, abatement or other contest, including any costs associated with obtaining the opinion of independent tax counsel described in this Article 5.17.7. The Participating TO may abandon any contest if the Interconnection Customer fails to provide payment to the Participating TO within thirty (30) Calendar Days of receiving such invoice.

At any time during the contest, the Participating TO may agree to a settlement either with the Interconnection Customer's consent or, if such consent is refused, after obtaining written advice from independent nationally-recognized tax counsel, selected by the Participating TO, but reasonably acceptable to the Interconnection Customer, that the proposed settlement represents a reasonable settlement given the hazards of litigation. The Interconnection Customer's obligation shall be based on the amount of the settlement agreed to by the Interconnection Customer, or if a higher amount, so much of the settlement that is supported by the written advice from nationally-recognized tax counsel selected under the terms of the preceding paragraph. The settlement amount shall be calculated on a fully grossed-up basis to cover any related cost consequences of the current tax liability. The Participating TO may also settle any tax controversy without receiving the Interconnection Customer's consent or any such written advice; however, any such settlement will relieve the Interconnection Customer from any obligation to indemnify the Participating TO for the tax at issue in the contest (unless the failure to obtain written advice is attributable to the Interconnection Customer's unreasonable refusal to the appointment of independent tax counsel).

5.17.8 Refund. In the event that (a) a private letter ruling is issued to the Participating TO which holds that any amount paid or the value of any property transferred by the Interconnection Customer to the Participating TO under the terms of this LGIA is not subject to federal income taxation, (b) any legislative change or administrative announcement, notice, ruling

or other determination makes it reasonably clear to the Participating TO in good faith that any amount paid or the value of any property transferred by the Interconnection Customer to the Participating TO under the terms of this LGIA is not taxable to the Participating TO, (c) any abatement, appeal, protest, or other contest results in a determination that any payments or transfers made by the Interconnection Customer to the Participating TO are not subject to federal income tax, or (d) if the Participating TO receives a refund from any taxing authority for any overpayment of tax attributable to any payment or property transfer made by the Interconnection Customer to the Participating TO pursuant to this LGIA, the Participating TO shall promptly refund to the Interconnection Customer the following:

(i) any payment made by Interconnection Customer under this Article 5.17 for taxes that is attributable to the amount determined to be non-taxable, together with interest thereon,

(ii) interest on any amounts paid by the Interconnection Customer to the Participating TO for such taxes which the Participating TO did not submit to the taxing authority, calculated in accordance with the methodology set forth in FERC's regulations at 18 C.F.R. §35.19a(a)(2)(iii) from the date payment was made by the Interconnection Customer to the date the Participating TO refunds such payment to the Interconnection Customer, and

(iii) with respect to any such taxes paid by the Participating TO, any refund or credit the Participating TO receives or to which it may be entitled from any Governmental Authority, interest (or that portion thereof attributable to the payment described in clause (i), above) owed to the Participating TO for such overpayment of taxes (including any reduction in interest otherwise payable by the Participating TO to any Governmental Authority resulting from an offset or credit); provided, however, that the Participating TO will remit such amount promptly to the Interconnection Customer only after and to the extent that the Participating TO has received a tax refund, credit or offset from any Governmental Authority for any applicable overpayment of income tax related to the Participating TO's Interconnection Facilities.

The intent of this provision is to leave the Parties, to the extent practicable, in the event that no taxes are due with respect to any payment for Interconnection Facilities and Network Upgrades hereunder, in the same position they would have been in had no such tax payments been made.

5.17.9 Taxes Other Than Income Taxes. Upon the timely request by the Interconnection Customer, and at the Interconnection Customer's sole expense, the CAISO or Participating TO may appeal, protest, seek

abatement of, or otherwise contest any tax (other than federal or state income tax) asserted or assessed against the CAISO or Participating TO for which the Interconnection Customer may be required to reimburse the CAISO or Participating TO under the terms of this LGIA. The Interconnection Customer shall pay to the Participating TO on a periodic basis, as invoiced by the Participating TO, the Participating TO's documented reasonable costs of prosecuting such appeal, protest, abatement, or other contest. The Interconnection Customer, the CAISO, and the Participating TO shall cooperate in good faith with respect to any such contest. Unless the payment of such taxes is a prerequisite to an appeal or abatement or cannot be deferred, no amount shall be payable by the Interconnection Customer to the CAISO or Participating TO for such taxes until they are assessed by a final, non-appealable order by any court or agency of competent jurisdiction. In the event that a tax payment is withheld and ultimately due and payable after appeal, the Interconnection Customer will be responsible for all taxes, interest and penalties, other than penalties attributable to any delay caused by the Participating TO.

5.18 Tax Status. Each Party shall cooperate with the others to maintain the other Parties' tax status. Nothing in this LGIA is intended to adversely affect the CAISO's or any Participating TO's tax exempt status with respect to the issuance of bonds including, but not limited to, Local Furnishing Bonds.

5.19 Modification.

5.19.1 General. The Interconnection Customer or the Participating TO may undertake modifications to its facilities, subject to the provisions of this LGIA and the CAISO Tariff. If a Party plans to undertake a modification that reasonably may be expected to affect the other Parties' facilities, that Party shall provide to the other Parties sufficient information regarding such modification so that the other Parties may evaluate the potential impact of such modification prior to commencement of the work. Such information shall be deemed to be confidential hereunder and shall include information concerning the timing of such modifications and whether such modifications are expected to interrupt the flow of electricity from the Large Generating Facility. The Party desiring to perform such work shall provide the relevant drawings, plans, and specifications to the other Parties at least ninety (90) Calendar Days in advance of the commencement of the work or such shorter period upon which the Parties may agree, which agreement shall not unreasonably be withheld, conditioned or delayed.

In the case of Large Generating Facility modifications that do not require the Interconnection Customer to submit an Interconnection Request, the CAISO or Participating TO shall provide, within thirty (30) Calendar Days

(or such other time as the Parties may agree), an estimate of any additional modifications to the CAISO Controlled Grid, Participating TO's Interconnection Facilities, Network Upgrades or Distribution Upgrades necessitated by such Interconnection Customer modification and a good faith estimate of the costs thereof. The Participating TO and the CAISO shall determine if a Large Generating Facility modification is a Material Modification in accordance with the LGIP.

5.19.2 Standards. Any additions, modifications, or replacements made to a Party's facilities shall be designed, constructed and operated in accordance with this LGIA and Good Utility Practice.

5.19.3 Modification Costs. The Interconnection Customer shall not be directly assigned the costs of any additions, modifications, or replacements that the Participating TO makes to the Participating TO's Interconnection Facilities or the Participating TO's Transmission System to facilitate the interconnection of a third party to the Participating TO's Interconnection Facilities or the Participating TO's Transmission System, or to provide transmission service to a third party under the CAISO Tariff. The Interconnection Customer shall be responsible for the costs of any additions, modifications, or replacements to the Interconnection Facilities that may be necessary to maintain or upgrade such Interconnection Facilities consistent with Applicable Laws and Regulations, Applicable Reliability Standards or Good Utility Practice.

ARTICLE 6. TESTING AND INSPECTION

6.1 Pre-Commercial Operation Date Testing and Modifications. Prior to the Commercial Operation Date, the Participating TO shall test the Participating TO's Interconnection Facilities, Network Upgrades, and Distribution Upgrades and the Interconnection Customer shall test the Large Generating Facility and the Interconnection Customer's Interconnection Facilities to ensure their safe and reliable operation. Similar testing may be required after initial operation. Each Party shall make any modifications to its facilities that are found to be necessary as a result of such testing. The Interconnection Customer shall bear the cost of all such testing and modifications. The Interconnection Customer shall not commence initial parallel operation of an Electric Generating Unit with the Participating TO's Transmission System until the Participating TO provides prior written approval, which approval shall not be unreasonably withheld, for operation of such Electric Generating Unit. The Interconnection Customer shall generate test energy at the Large Generating Facility only if it has arranged for the delivery of such test energy.

6.2 Post-Commercial Operation Date Testing and Modifications. Each Party shall at its own expense perform routine inspection and testing of its facilities and

equipment in accordance with Good Utility Practice as may be necessary to ensure the continued interconnection of the Large Generating Facility with the Participating TO's Transmission System in a safe and reliable manner. Each Party shall have the right, upon advance written notice, to require reasonable additional testing of the other Party's facilities, at the requesting Party's expense, as may be in accordance with Good Utility Practice.

6.3 Right to Observe Testing. Each Party shall notify the other Parties at least fourteen (14) Calendar Days in advance of its performance of tests of its Interconnection Facilities or Generating Facility. The other Parties have the right, at their own expense, to observe such testing.

6.4 Right to Inspect. Each Party shall have the right, but shall have no obligation to: (i) observe another Party's tests and/or inspection of any of its System Protection Facilities and other protective equipment, including Power System Stabilizers; (ii) review the settings of another Party's System Protection Facilities and other protective equipment; and (iii) review another Party's maintenance records relative to the Interconnection Facilities, the System Protection Facilities and other protective equipment. A Party may exercise these rights from time to time as it deems necessary upon reasonable notice to the other Party. The exercise or non-exercise by a Party of any such rights shall not be construed as an endorsement or confirmation of any element or condition of the Interconnection Facilities or the System Protection Facilities or other protective equipment or the operation thereof, or as a warranty as to the fitness, safety, desirability, or reliability of same. Any information that a Party obtains through the exercise of any of its rights under this Article 6.4 shall be deemed to be Confidential Information and treated pursuant to Article 22 of this LGIA.

ARTICLE 7. METERING

7.1 General. Each Party shall comply with any Applicable Reliability Standards and the Applicable Reliability Council requirements. The Interconnection Customer and CAISO shall comply with the provisions of the CAISO Tariff regarding metering, including Section 10 of the CAISO Tariff. Unless otherwise agreed by the Participating TO and the Interconnection Customer, the Participating TO may install additional Metering Equipment at the Point of Interconnection prior to any operation of any Electric Generating Unit and shall own, operate, test and maintain such Metering Equipment. Power flows to and from the Large Generating Facility shall be measured at or, at the CAISO's or Participating TO's option for its respective Metering Equipment, compensated to, the Point of Interconnection. The CAISO shall provide metering quantities to the Interconnection Customer upon request in accordance with the CAISO Tariff by directly polling the CAISO's meter data acquisition system. The Interconnection Customer shall bear all reasonable documented costs associated with the

purchase, installation, operation, testing and maintenance of the Metering Equipment.

- 7.2 Check Meters.** The Interconnection Customer, at its option and expense, may install and operate, on its premises and on its side of the Point of Interconnection, one or more check meters to check the CAISO-polled meters or the Participating TO's meters. Such check meters shall be for check purposes only and shall not be used for the measurement of power flows for purposes of this LGIA, except in the case that no other means are available on a temporary basis at the option of the CAISO or the Participating TO. The check meters shall be subject at all reasonable times to inspection and examination by the CAISO or Participating TO or their designees. The installation, operation and maintenance thereof shall be performed entirely by the Interconnection Customer in accordance with Good Utility Practice.
- 7.3 Participating TO Retail Metering.** The Participating TO may install retail revenue quality meters and associated equipment, pursuant to the Participating TO's applicable retail tariffs.

ARTICLE 8. COMMUNICATIONS

- 8.1 Interconnection Customer Obligations.** The Interconnection Customer shall maintain satisfactory operating communications with the CAISO in accordance with the provisions of the CAISO Tariff and with the Participating TO's dispatcher or representative designated by the Participating TO. The Interconnection Customer shall provide standard voice line, dedicated voice line and facsimile communications at its Large Generating Facility control room or central dispatch facility through use of either the public telephone system, or a voice communications system that does not rely on the public telephone system. The Interconnection Customer shall also provide the dedicated data circuit(s) necessary to provide Interconnection Customer data to the CAISO and Participating TO as set forth in Appendix D, Security Arrangements Details. The data circuit(s) shall extend from the Large Generating Facility to the location(s) specified by the CAISO and Participating TO. Any required maintenance of such communications equipment shall be performed by the Interconnection Customer. Operational communications shall be activated and maintained under, but not be limited to, the following events: system paralleling or separation, scheduled and unscheduled shutdowns, equipment clearances, and hourly and daily load data.
- 8.2 Remote Terminal Unit.** Prior to the Initial Synchronization Date of each Electric Generating Unit, a Remote Terminal Unit, or equivalent data collection and transfer equipment acceptable to the Parties, shall be installed by the Interconnection Customer, or by the Participating TO at the Interconnection Customer's expense, to gather accumulated and instantaneous data to be telemetered to the location(s) designated by the CAISO and by the Participating

TO through use of a dedicated point-to-point data circuit(s) as indicated in Article 8.1.

Telemetry to the CAISO shall be provided in accordance with the CAISO's technical standards for direct telemetry. For telemetry to the Participating TO, the communication protocol for the data circuit(s) shall be specified by the Participating TO. Instantaneous bi-directional real power and reactive power flow and any other required information must be telemetered directly to the location(s) specified by the Participating TO.

Each Party will promptly advise the other Parties if it detects or otherwise learns of any metering, telemetry or communications equipment errors or malfunctions that require the attention and/or correction by another Party. The Party owning such equipment shall correct such error or malfunction as soon as reasonably feasible.

- 8.3 No Annexation.** Any and all equipment placed on the premises of a Party shall be and remain the property of the Party providing such equipment regardless of the mode and manner of annexation or attachment to real property, unless otherwise mutually agreed by the Parties.

ARTICLE 9. OPERATIONS

- 9.1 General.** Each Party shall comply with Applicable Reliability Standards and the Applicable Reliability Council requirements. Each Party shall provide to the other Party all information that may reasonably be required by the other Party to comply with Applicable Laws and Regulations and Applicable Reliability Standards.
- 9.2 Balancing Authority Area Notification.** At least three months before Initial Synchronization Date, the Interconnection Customer shall notify the CAISO and Participating TO in writing of the Balancing Authority Area in which the Large Generating Facility intends to be located. If the Interconnection Customer intends to locate the Large Generating Facility in a Balancing Authority Area other than the Balancing Authority Area within whose electrically metered boundaries the Large Generating Facility is located, and if permitted to do so by the relevant transmission tariffs, all necessary arrangements, including but not limited to those set forth in Article 7 and Article 8 of this LGIA, and remote Balancing Authority Area generator interchange agreements, if applicable, and the appropriate measures under such agreements, shall be executed and implemented prior to the placement of the Large Generating Facility in the other Balancing Authority Area.
- 9.3 CAISO and Participating TO Obligations.** The CAISO and Participating TO shall cause the Participating TO's Transmission System to be operated and

controlled in a safe and reliable manner and in accordance with this LGIA. The Participating TO at the Interconnection Customer's expense shall cause the Participating TO's Interconnection Facilities to be operated, maintained and controlled in a safe and reliable manner and in accordance with this LGIA. The CAISO and Participating TO may provide operating instructions to the Interconnection Customer consistent with this LGIA and Participating TO and CAISO operating protocols and procedures as they may change from time to time. The Participating TO and CAISO will consider changes to their operating protocols and procedures proposed by the Interconnection Customer.

9.4 Interconnection Customer Obligations. The Interconnection Customer shall at its own expense operate, maintain and control the Large Generating Facility and the Interconnection Customer's Interconnection Facilities in a safe and reliable manner and in accordance with this LGIA. The Interconnection Customer shall operate the Large Generating Facility and the Interconnection Customer's Interconnection Facilities in accordance with all applicable requirements of the Balancing Authority Area of which it is part, including such requirements as set forth in Appendix C, Interconnection Details, of this LGIA. Appendix C, Interconnection Details, will be modified to reflect changes to the requirements as they may change from time to time. A Party may request that another Party provide copies of the requirements set forth in Appendix C, Interconnection Details, of this LGIA. The Interconnection Customer shall not commence Commercial Operation of an Electric Generating Unit with the Participating TO's Transmission System until the Participating TO provides prior written approval, which approval shall not be unreasonably withheld, for operation of such Electric Generating Unit.

9.5 Start-Up and Synchronization. Consistent with the Parties' mutually acceptable procedures, the Interconnection Customer is responsible for the proper synchronization of each Electric Generating Unit to the CAISO Controlled Grid.

9.6 Reactive Power.

9.6.1 Power Factor Design Criteria. For all Generating Facilities other than Asynchronous Generating Facilities, the Interconnection Customer shall design the Large Generating Facility to maintain a composite power delivery at continuous rated power output at the terminals of the Electric Generating Unit at a power factor within the range of 0.95 leading to 0.90 lagging, unless the CAISO has established different requirements that apply to all generators in the Balancing Authority Area on a comparable basis. For Asynchronous Generating Facilities, the Interconnection Customer shall design the Large Generating Facility to maintain power factor criteria in accordance with Appendix H of this LGIA.

9.6.2 Voltage Schedules. Once the Interconnection Customer has synchronized an Electric Generating Unit with the CAISO Controlled Grid, the CAISO or Participating TO shall require the Interconnection Customer to maintain a voltage schedule by operating the Electric Generating Unit to produce or absorb reactive power within the design limitations of the Electric Generating Unit set forth in Article 9.6.1 (Power Factor Design Criteria). CAISO's voltage schedules shall treat all sources of reactive power in the Balancing Authority Area in an equitable and not unduly discriminatory manner. The Participating TO shall exercise Reasonable Efforts to provide the Interconnection Customer with such schedules at least one (1) day in advance, and the CAISO or Participating TO may make changes to such schedules as necessary to maintain the reliability of the CAISO Controlled Grid or the Participating TO's electric system. The Interconnection Customer shall operate the Electric Generating Unit to maintain the specified output voltage or power factor within the design limitations of the Electric Generating Unit set forth in Article 9.6.1 (Power Factor Design Criteria), and as may be required by the CAISO to operate the Electric Generating Unit at a specific voltage schedule within the design limitations set forth in Article 9.6.1. If the Interconnection Customer is unable to maintain the specified voltage or power factor, it shall promptly notify the CAISO and the Participating TO.

9.6.2.1 Governors and Regulators. Whenever an Electric Generating Unit is operated in parallel with the CAISO Controlled Grid and the speed governors (if installed on the Electric Generating Unit pursuant to Good Utility Practice) and voltage regulators are capable of operation, the Interconnection Customer shall operate the Electric Generating Unit with its speed governors and voltage regulators in automatic operation. If the Electric Generating Unit's speed governors and voltage regulators are not capable of such automatic operation, the Interconnection Customer shall immediately notify the CAISO and the Participating TO and ensure that the Electric Generating Unit operates as specified in Article 9.6.2 through manual operation and that such Electric Generating Unit's reactive power production or absorption (measured in MVARs) are within the design capability of the Electric Generating Unit(s) and steady state stability limits. The Interconnection Customer shall restore the speed governors and voltage regulators to automatic operation as soon as possible. If the Large Generating Facility's speed governors and voltage regulators are improperly tuned or malfunctioning, the CAISO shall have the right to order the reduction in output or disconnection of the Large Generating Facility if the reliability of the CAISO Controlled Grid would be adversely affected. The Interconnection Customer shall not cause its Large Generating Facility to disconnect automatically or instantaneously from the CAISO

Controlled Grid or trip any Electric Generating Unit comprising the Large Generating Facility for an under or over frequency condition unless the abnormal frequency condition persists for a time period beyond the limits set forth in ANSI/IEEE Standard C37.106, or such other standard as applied to other generators in the Balancing Authority Area on a comparable basis.

9.6.3 Payment for Reactive Power. CAISO is required to pay the Interconnection Customer for reactive power that Interconnection Customer provides or absorbs from an Electric Generating Unit when the CAISO requests the Interconnection Customer to operate its Electric Generating Unit outside the range specified in Article 9.6.1, provided that if the CAISO pays other generators for reactive power service within the specified range, it must also pay the Interconnection Customer. Payments shall be pursuant to Article 11.6 or such other agreement to which the CAISO and Interconnection Customer have otherwise agreed.

9.7 Outages and Interruptions.

9.7.1 Outages.

9.7.1.1 Outage Authority and Coordination. Each Party may in accordance with Good Utility Practice in coordination with the other Parties remove from service any of its respective Interconnection Facilities or Network Upgrades that may impact another Party's facilities as necessary to perform maintenance or testing or to install or replace equipment. Absent an Emergency Condition, the Party scheduling a removal of such facility(ies) from service will use Reasonable Efforts to schedule such removal on a date and time mutually acceptable to all Parties. In all circumstances any Party planning to remove such facility(ies) from service shall use Reasonable Efforts to minimize the effect on the other Parties of such removal.

9.7.1.2 Outage Schedules. The CAISO shall post scheduled outages of CAISO Controlled Grid facilities in accordance with the provisions of the CAISO Tariff. The Interconnection Customer shall submit its planned maintenance schedules for the Large Generating Facility to the CAISO in accordance with the CAISO Tariff. The Interconnection Customer shall update its planned maintenance schedules in accordance with the CAISO Tariff. The CAISO may request the Interconnection Customer to reschedule its maintenance as necessary to maintain the reliability of the CAISO Controlled Grid in accordance with the CAISO Tariff. Such planned maintenance schedules and updates and changes to such schedules shall be provided by the Interconnection Customer to the

Participating TO concurrently with their submittal to the CAISO. The CAISO shall compensate the Interconnection Customer for any additional direct costs that the Interconnection Customer incurs as a result of having to reschedule maintenance in accordance with the CAISO Tariff. The Interconnection Customer will not be eligible to receive compensation, if during the twelve (12) months prior to the date of the scheduled maintenance, the Interconnection Customer had modified its schedule of maintenance activities.

9.7.1.3 Outage Restoration. If an outage on a Party's Interconnection Facilities or Network Upgrades adversely affects another Party's operations or facilities, the Party that owns or controls the facility that is out of service shall use Reasonable Efforts to promptly restore such facility(ies) to a normal operating condition consistent with the nature of the outage. The Party that owns or controls the facility that is out of service shall provide the other Parties, to the extent such information is known, information on the nature of the Emergency Condition, if the outage is caused by an Emergency Condition, an estimated time of restoration, and any corrective actions required. Initial verbal notice shall be followed up as soon as practicable with written notice explaining the nature of the outage, if requested by a Party, which may be provided by e-mail or facsimile.

9.7.2 Interruption of Service. If required by Good Utility Practice to do so, the CAISO or the Participating TO may require the Interconnection Customer to interrupt or reduce deliveries of electricity if such delivery of electricity could adversely affect the CAISO's or the Participating TO's ability to perform such activities as are necessary to safely and reliably operate and maintain the Participating TO's electric system or the CAISO Controlled Grid. The following provisions shall apply to any interruption or reduction permitted under this Article 9.7.2:

9.7.2.1 The interruption or reduction shall continue only for so long as reasonably necessary under Good Utility Practice;

9.7.2.2 Any such interruption or reduction shall be made on an equitable, non-discriminatory basis with respect to all generating facilities directly connected to the CAISO Controlled Grid, subject to any conditions specified in this LGIA;

9.7.2.3 When the interruption or reduction must be made under circumstances which do not allow for advance notice, the CAISO or Participating TO, as applicable, shall notify the Interconnection Customer by telephone as soon as practicable of the reasons for the curtailment, interruption, or reduction, and, if known, its

expected duration. Telephone notification shall be followed by written notification, if requested by the Interconnection Customer, as soon as practicable;

9.7.2.4 Except during the existence of an Emergency Condition, the CAISO or Participating TO shall notify the Interconnection Customer in advance regarding the timing of such interruption or reduction and further notify the Interconnection Customer of the expected duration. The CAISO or Participating TO shall coordinate with the Interconnection Customer using Good Utility Practice to schedule the interruption or reduction during periods of least impact to the Interconnection Customer, the CAISO, and the Participating TO;

9.7.2.5 The Parties shall cooperate and coordinate with each other to the extent necessary in order to restore the Large Generating Facility, Interconnection Facilities, the Participating TO's Transmission System, and the CAISO Controlled Grid to their normal operating state, consistent with system conditions and Good Utility Practice.

9.7.3 Under-Frequency and Over Frequency Conditions. The CAISO Controlled Grid is designed to automatically activate a load-shed program as required by Applicable Reliability Standards and the Applicable Reliability Council in the event of an under-frequency system disturbance. The Interconnection Customer shall implement under-frequency and over-frequency protection set points for the Large Generating Facility as required by Applicable Reliability Standards and the Applicable Reliability Council to ensure "ride through" capability. Large Generating Facility response to frequency deviations of pre-determined magnitudes, both under-frequency and over-frequency deviations, shall be studied and coordinated with the Participating TO and CAISO in accordance with Good Utility Practice. The term "ride through" as used herein shall mean the ability of a Generating Facility to stay connected to and synchronized with the CAISO Controlled Grid during system disturbances within a range of under-frequency and over-frequency conditions, in accordance with Good Utility Practice. Asynchronous Generating Facilities shall be subject to frequency ride through capability requirements in accordance with Appendix H to this LGIA.

9.7.4 System Protection and Other Control Requirements.

9.7.4.1 System Protection Facilities. The Interconnection Customer shall, at its expense, install, operate and maintain System Protection Facilities as a part of the Large Generating Facility or the Interconnection Customer's Interconnection Facilities.

The Participating TO shall install at the Interconnection Customer's expense any System Protection Facilities that may be required on the Participating TO's Interconnection Facilities or the Participating TO's Transmission System as a result of the interconnection of the Large Generating Facility and the Interconnection Customer's Interconnection Facilities.

9.7.4.2 The Participating TO's and Interconnection Customer's protection facilities shall be designed and coordinated with other systems in accordance with Applicable Reliability Standards, Applicable Reliability Council criteria, and Good Utility Practice.

9.7.4.3 The Participating TO and Interconnection Customer shall each be responsible for protection of its facilities consistent with Good Utility Practice.

9.7.4.4 The Participating TO's and Interconnection Customer's protective relay design shall incorporate the necessary test switches to perform the tests required in Article 6. The required test switches will be placed such that they allow operation of lockout relays while preventing breaker failure schemes from operating and causing unnecessary breaker operations and/or the tripping of the Interconnection Customer's Electric Generating Units.

9.7.4.5 The Participating TO and Interconnection Customer will test, operate and maintain System Protection Facilities in accordance with Good Utility Practice and, if applicable, the requirements of the Participating TO's Interconnection Handbook.

9.7.4.6 Prior to the in-service date, and again prior to the Commercial Operation Date, the Participating TO and Interconnection Customer or their agents shall perform a complete calibration test and functional trip test of the System Protection Facilities. At intervals suggested by Good Utility Practice, the standards and procedures of the Participating TO, including, if applicable, the requirements of the Participating TO's Interconnection Handbook, and following any apparent malfunction of the System Protection Facilities, each Party shall perform both calibration and functional trip tests of its System Protection Facilities. These tests do not require the tripping of any in-service generation unit. These tests do, however, require that all protective relays and lockout contacts be activated.

9.7.5 Requirements for Protection. In compliance with Good Utility Practice and, if applicable, the requirements of the Participating TO's

Interconnection Handbook, the Interconnection Customer shall provide, install, own, and maintain relays, circuit breakers and all other devices necessary to remove any fault contribution of the Large Generating Facility to any short circuit occurring on the Participating TO's Transmission System not otherwise isolated by the Participating TO's equipment, such that the removal of the fault contribution shall be coordinated with the protective requirements of the Participating TO's Transmission System. Such protective equipment shall include, without limitation, a disconnecting device with fault current-interrupting capability located between the Large Generating Facility and the Participating TO's Transmission System at a site selected upon mutual agreement (not to be unreasonably withheld, conditioned or delayed) of the Parties. The Interconnection Customer shall be responsible for protection of the Large Generating Facility and the Interconnection Customer's other equipment from such conditions as negative sequence currents, over- or under-frequency, sudden load rejection, over- or under-voltage, and generator loss-of-field. The Interconnection Customer shall be solely responsible to disconnect the Large Generating Facility and the Interconnection Customer's other equipment if conditions on the CAISO Controlled Grid could adversely affect the Large Generating Facility.

9.7.6 Power Quality. Neither the Participating TO's nor the Interconnection Customer's facilities shall cause excessive voltage flicker nor introduce excessive distortion to the sinusoidal voltage or current waves as defined by ANSI Standard C84.1-1989, in accordance with IEEE Standard 519, any applicable superseding electric industry standard, or any alternative Applicable Reliability Standard or Applicable Reliability Council standard. In the event of a conflict among ANSI Standard C84.1-1989, any applicable superseding electric industry standard, or any alternative Applicable Reliability Standard or Applicable Reliability Council standard, the alternative Applicable Reliability Standard or Applicable Reliability Council standard shall control.

9.8 Switching and Tagging Rules. Each Party shall provide the other Parties a copy of its switching and tagging rules that are applicable to the other Parties' activities. Such switching and tagging rules shall be developed on a non-discriminatory basis. The Parties shall comply with applicable switching and tagging rules, as amended from time to time, in obtaining clearances for work or for switching operations on equipment.

9.9 Use of Interconnection Facilities by Third Parties.

9.9.1 Purpose of Interconnection Facilities. Except as may be required by Applicable Laws and Regulations, or as otherwise agreed to among the Parties, the Interconnection Facilities shall be constructed for the sole purpose of interconnecting the Large Generating Facility to the

Participating TO's Transmission System and shall be used for no other purpose.

9.9.2 Third Party Users. If required by Applicable Laws and Regulations or if the Parties mutually agree, such agreement not to be unreasonably withheld, to allow one or more third parties to use the Participating TO's Interconnection Facilities, or any part thereof, the Interconnection Customer will be entitled to compensation for the capital expenses it incurred in connection with the Interconnection Facilities based upon the pro rata use of the Interconnection Facilities by the Participating TO, all third party users, and the Interconnection Customer, in accordance with Applicable Laws and Regulations or upon some other mutually-agreed upon methodology. In addition, cost responsibility for ongoing costs, including operation and maintenance costs associated with the Interconnection Facilities, will be allocated between the Interconnection Customer and any third party users based upon the pro rata use of the Interconnection Facilities by the Participating TO, all third party users, and the Interconnection Customer, in accordance with Applicable Laws and Regulations or upon some other mutually agreed upon methodology. If the issue of such compensation or allocation cannot be resolved through such negotiations, it shall be submitted to FERC for resolution.

9.10 Disturbance Analysis Data Exchange. The Parties will cooperate with one another in the analysis of disturbances to either the Large Generating Facility or the CAISO Controlled Grid by gathering and providing access to any information relating to any disturbance, including information from oscillography, protective relay targets, breaker operations and sequence of events records, and any disturbance information required by Good Utility Practice.

ARTICLE 10. MAINTENANCE

10.1 Participating TO Obligations. The Participating TO shall maintain the Participating TO's Transmission System and the Participating TO's Interconnection Facilities in a safe and reliable manner and in accordance with this LGIA.

10.2 Interconnection Customer Obligations. The Interconnection Customer shall maintain the Large Generating Facility and the Interconnection Customer's Interconnection Facilities in a safe and reliable manner and in accordance with this LGIA.

10.3 Coordination. The Parties shall confer regularly to coordinate the planning, scheduling and performance of preventive and corrective maintenance on the Large Generating Facility and the Interconnection Facilities.

- 10.4 Secondary Systems.** The Participating TO and Interconnection Customer shall cooperate with the other Parties in the inspection, maintenance, and testing of control or power circuits that operate below 600 volts, AC or DC, including, but not limited to, any hardware, control or protective devices, cables, conductors, electric raceways, secondary equipment panels, transducers, batteries, chargers, and voltage and current transformers that directly affect the operation of a Party's facilities and equipment which may reasonably be expected to impact the other Parties. Each Party shall provide advance notice to the other Parties before undertaking any work on such circuits, especially on electrical circuits involving circuit breaker trip and close contacts, current transformers, or potential transformers.
- 10.5 Operating and Maintenance Expenses.** Subject to the provisions herein addressing the use of facilities by others, and except for operations and maintenance expenses associated with modifications made for providing interconnection or transmission service to a third party and such third party pays for such expenses, the Interconnection Customer shall be responsible for all reasonable expenses including overheads, associated with: (1) owning, operating, maintaining, repairing, and replacing the Interconnection Customer's Interconnection Facilities; and (2) operation, maintenance, repair and replacement of the Participating TO's Interconnection Facilities.

ARTICLE 11. PERFORMANCE OBLIGATION

- 11.1 Interconnection Customer's Interconnection Facilities.** The Interconnection Customer shall design, procure, construct, install, own and/or control the Interconnection Customer's Interconnection Facilities described in Appendix A at its sole expense.
- 11.2 Participating TO's Interconnection Facilities.** The Participating TO shall design, procure, construct, install, own and/or control the Participating TO's Interconnection Facilities described in Appendix A at the sole expense of the Interconnection Customer. Unless the Participating TO elects to fund the capital for the Participating TO's Interconnection Facilities, they shall be solely funded by the Interconnection Customer.
- 11.3 Network Upgrades and Distribution Upgrades.** The Participating TO shall design, procure, construct, install, and own the Network Upgrades and Distribution Upgrades described in Appendix A. The Interconnection Customer shall be responsible for all costs related to Distribution Upgrades. Unless the Participating TO elects to fund the capital for the Distribution Upgrades and Network Upgrades, they shall be funded by the Interconnection Customer in an amount determined pursuant to the methodology set forth in Section 13 of the LGIP. This specific amount is set forth in Appendix G to this LGIA.

11.4 Transmission Credits. No later than thirty (30) Calendar Days prior to the Commercial Operation Date, the Interconnection Customer may make a one-time election by written notice to the CAISO and the Participating TO to receive Congestion Revenue Rights as defined in and as available under the CAISO Tariff at the time of the election in accordance with the CAISO Tariff, in lieu of a refund of the cost of Network Upgrades in accordance with Article 11.4.1.

11.4.1 Repayment of Amounts Advanced for Network Upgrades. Upon the Commercial Operation Date, the Interconnection Customer shall be entitled to a repayment, equal to the total amount paid to the Participating TO for the costs of Network Upgrades for which it is responsible, as set forth in Appendix G. Such amount shall include any tax gross-up or other tax-related payments associated with Network Upgrades not refunded to the Interconnection Customer pursuant to Article 5.17.8 or otherwise, and shall be paid to the Interconnection Customer by the Participating TO on a dollar-for-dollar basis either through (1) direct payments made on a levelized basis over the five-year period commencing on the Commercial Operation Date; or (2) any alternative payment schedule that is mutually agreeable to the Interconnection Customer and Participating TO, provided that such amount is paid within five (5) years from the Commercial Operation Date. Notwithstanding the foregoing, if this LGIA terminates within five (5) years from the Commercial Operation Date, the Participating TO's obligation to pay refunds to the Interconnection Customer shall cease as of the date of termination. Any repayment shall include interest calculated in accordance with the methodology set forth in FERC's regulations at 18 C.F.R. §35.19a(a)(2)(iii) from the date of any payment for Network Upgrades through the date on which the Interconnection Customer receives a repayment of such payment. Interest shall continue to accrue on the repayment obligation so long as this LGIA is in effect. The Interconnection Customer may assign such repayment rights to any person.

If the Large Generating Facility fails to achieve Commercial Operation, but it or another Generating Facility is later constructed and makes use of the Network Upgrades, the Participating TO shall at that time reimburse Interconnection Customer for the amounts advanced for the Network Upgrades. Before any such reimbursement can occur, the Interconnection Customer, or the entity that ultimately constructs the Generating Facility, if different, is responsible for identifying and demonstrating to the Participating TO the appropriate entity to which reimbursement must be made in order to implement the intent of this reimbursement obligation.

11.4.2 Special Provisions for Affected Systems. The Interconnection Customer shall enter into an agreement with the owner of the Affected System and/or other affected owners of portions of the CAISO Controlled

Grid, as applicable, in accordance with the LGIP. Such agreement shall specify the terms governing payments to be made by the Interconnection Customer to the owner of the Affected System and/or other affected owners of portions of the CAISO Controlled Grid as well as the repayment by the owner of the Affected System and/or other affected owners of portions of the CAISO Controlled Grid. In no event shall the Participating TO be responsible for the repayment for any facilities that are not part of the Participating TO's Transmission System. In the event the Participating TO is a joint owner with an Affected System or with any other co-owner of a facility affected by the Large Generating Facility, the Participating TO's obligation to reimburse the Interconnection Customer for payments made to address the impacts of the Large Generating Facility on the system shall not exceed the proportionate amount of the cost of any upgrades attributable to the proportion of the jointly-owned facility owned by the Participating TO.

11.4.3 Notwithstanding any other provision of this LGIA, nothing herein shall be construed as relinquishing or foreclosing any rights, including but not limited to firm transmission rights, capacity rights, Congestion Revenue Rights, or transmission credits, that the Interconnection Customer shall be entitled to, now or in the future under any other agreement or tariff as a result of, or otherwise associated with, the transmission capacity, if any, created by the Network Upgrades, including the right to obtain cash reimbursements, merchant transmission Congestion Revenue Rights in accordance with Section 36.11 of the CAISO Tariff, or transmission credits for transmission service that is not associated with the Large Generating Facility.

11.5 Provision of Interconnection Financial Security. The Interconnection Customer is obligated to provide all necessary Interconnection Financial Security required under Section 9 of the LGIP in a manner acceptable under Section 9 of the LGIP. Failure to satisfy the LGIP's requirements for the provision of Interconnection Financial Security shall result in the Interconnection Request being deemed withdrawn and subject to LGIP Section 3.8.

11.6 Interconnection Customer Compensation. If the CAISO requests or directs the Interconnection Customer to provide a service pursuant to Articles 9.6.3 (Payment for Reactive Power) or 13.5.1 of this LGIA, the CAISO shall compensate the Interconnection Customer in accordance with the CAISO Tariff.

11.6.1 Interconnection Customer Compensation for Actions During Emergency Condition. The CAISO shall compensate the Interconnection Customer in accordance with the CAISO Tariff for its provision of real and reactive power and other Emergency Condition services that the Interconnection Customer provides to support the CAISO

Controlled Grid during an Emergency Condition in accordance with Article 11.6.

ARTICLE 12. INVOICE

- 12.1 General.** The Participating TO shall submit to the Interconnection Customer, on a monthly basis, invoices of amounts due pursuant to this LGIA for the preceding month. Each invoice shall state the month to which the invoice applies and fully describe the services and equipment provided. The Parties may discharge mutual debts and payment obligations due and owing to each other on the same date through netting, in which case all amounts a Party owes to the other Party under this LGIA, including interest payments or credits, shall be netted so that only the net amount remaining due shall be paid by the owing Party. Notwithstanding the foregoing, any invoices between the CAISO and another Party shall be submitted and paid in accordance with the CAISO Tariff.
- 12.2 Final Invoice.** As soon as reasonably practicable, but within twelve months after completion of the construction of the Participating TO's Interconnection Facilities, Network Upgrades, and Distribution Upgrades, the Participating TO shall provide an invoice of the final cost of the construction of the Participating TO's Interconnection Facilities, Network Upgrades, and Distribution Upgrades, and shall set forth such costs in sufficient detail to enable the Interconnection Customer to compare the actual costs with the estimates and to ascertain deviations, if any, from the cost estimates. With respect to costs associated with the Participating TO's Interconnection Facilities and Distribution Upgrades, the Participating TO shall refund to the Interconnection Customer any amount by which the actual payment by the Interconnection Customer for estimated costs exceeds the actual costs of construction within thirty (30) Calendar Days of the issuance of such final construction invoice; or, in the event the actual costs of construction exceed the Interconnection Customer's actual payment for estimated costs, then the Interconnection Customer shall pay to the Participating TO any amount by which the actual costs of construction exceed the actual payment by the Interconnection Customer for estimated costs within thirty (30) Calendar Days of the issuance of such final construction invoice. With respect to costs associated with Network Upgrades, the Participating TO shall refund to the Interconnection Customer any amount by which the actual payment by the Interconnection Customer for estimated costs exceeds the actual costs of construction multiplied by the Interconnection Customer's percentage share of those costs, as set forth in Appendix G to this LGIA within thirty (30) Calendar Days of the issuance of such final construction invoice. In the event the actual costs of construction multiplied by the Interconnection Customer's percentage share of those costs exceed the Interconnection Customer's actual payment for estimated costs, then the Participating TO shall recover such difference through its transmission service rates.

- 12.3 Payment.** Invoices shall be rendered to the Interconnection Customer at the address specified in Appendix F. The Interconnection Customer shall pay, or Participating TO shall refund, the amounts due within thirty (30) Calendar Days of the Interconnection Customer's receipt of the invoice. All payments shall be made in immediately available funds payable to the Interconnection Customer or Participating TO, or by wire transfer to a bank named and account designated by the invoicing Interconnection Customer or Participating TO. Payment of invoices by any Party will not constitute a waiver of any rights or claims any Party may have under this LGIA.
- 12.4 Disputes.** In the event of a billing dispute between the Interconnection Customer and the Participating TO, the Participating TO and the CAISO shall continue to provide Interconnection Service under this LGIA as long as the Interconnection Customer: (i) continues to make all payments not in dispute; and (ii) pays to the Participating TO or into an independent escrow account the portion of the invoice in dispute, pending resolution of such dispute. If the Interconnection Customer fails to meet these two requirements for continuation of service, then the Participating TO may provide notice to the Interconnection Customer of a Default pursuant to Article 17. Within thirty (30) Calendar Days after the resolution of the dispute, the Party that owes money to the other Party shall pay the amount due with interest calculated in accordance with the methodology set forth in FERC's Regulations at 18 C.F.R. § 35.19a(a)(2)(iii). Notwithstanding the foregoing, any billing dispute between the CAISO and another Party shall be resolved in accordance with the provisions of Article 27 of this LGIA.

ARTICLE 13. EMERGENCIES

- 13.1 [Reserved]**
- 13.2 Obligations.** Each Party shall comply with the Emergency Condition procedures of the CAISO, NERC, the Applicable Reliability Council, Applicable Reliability Standards, Applicable Laws and Regulations, and any emergency procedures set forth in this LGIA.
- 13.3 Notice.** The Participating TO or the CAISO shall notify the Interconnection Customer promptly when it becomes aware of an Emergency Condition that affects the Participating TO's Interconnection Facilities or Distribution System or the CAISO Controlled Grid, respectively, that may reasonably be expected to affect the Interconnection Customer's operation of the Large Generating Facility or the Interconnection Customer's Interconnection Facilities. The Interconnection Customer shall notify the Participating TO and the CAISO promptly when it becomes aware of an Emergency Condition that affects the Large Generating Facility or the Interconnection Customer's Interconnection Facilities that may reasonably be expected to affect the CAISO Controlled Grid or the Participating

TO's Interconnection Facilities. To the extent information is known, the notification shall describe the Emergency Condition, the extent of the damage or deficiency, the expected effect on the operation of the Interconnection Customer's or Participating TO's facilities and operations, its anticipated duration and the corrective action taken and/or to be taken. The initial notice shall be followed as soon as practicable with written notice, if requested by a Party, which may be provided by electronic mail or facsimile, or in the case of the CAISO may be publicly posted on the CAISO's internet web site.

13.4 Immediate Action. Unless, in the Interconnection Customer's reasonable judgment, immediate action is required, the Interconnection Customer shall obtain the consent of the CAISO and the Participating TO, such consent to not be unreasonably withheld, prior to performing any manual switching operations at the Large Generating Facility or the Interconnection Customer's Interconnection Facilities in response to an Emergency Condition declared by the Participating TO or CAISO or in response to any other emergency condition.

13.5 CAISO and Participating TO Authority.

13.5.1 General. The CAISO and Participating TO may take whatever actions or inactions, including issuance of dispatch instructions, with regard to the CAISO Controlled Grid or the Participating TO's Interconnection Facilities or Distribution System they deem necessary during an Emergency Condition in order to (i) preserve public health and safety, (ii) preserve the reliability of the CAISO Controlled Grid or the Participating TO's Interconnection Facilities or Distribution System, and (iii) limit or prevent damage, and (iv) expedite restoration of service.

The Participating TO and the CAISO shall use Reasonable Efforts to minimize the effect of such actions or inactions on the Large Generating Facility or the Interconnection Customer's Interconnection Facilities. The Participating TO or the CAISO may, on the basis of technical considerations, require the Large Generating Facility to mitigate an Emergency Condition by taking actions necessary and limited in scope to remedy the Emergency Condition, including, but not limited to, directing the Interconnection Customer to shut-down, start-up, increase or decrease the real or reactive power output of the Large Generating Facility; implementing a reduction or disconnection pursuant to Article 13.5.2; directing the Interconnection Customer to assist with black start (if available) or restoration efforts; or altering the outage schedules of the Large Generating Facility and the Interconnection Customer's Interconnection Facilities. Interconnection Customer shall comply with all of the CAISO's and Participating TO's operating instructions concerning Large Generating Facility real power and reactive power output within the manufacturer's design limitations of the Large Generating Facility's

equipment that is in service and physically available for operation at the time, in compliance with Applicable Laws and Regulations.

13.5.2 Reduction and Disconnection. The Participating TO or the CAISO may reduce Interconnection Service or disconnect the Large Generating Facility or the Interconnection Customer's Interconnection Facilities when such reduction or disconnection is necessary under Good Utility Practice due to Emergency Conditions. These rights are separate and distinct from any right of curtailment of the CAISO pursuant to the CAISO Tariff. When the CAISO or Participating TO can schedule the reduction or disconnection in advance, the CAISO or Participating TO shall notify the Interconnection Customer of the reasons, timing and expected duration of the reduction or disconnection. The CAISO or Participating TO shall coordinate with the Interconnection Customer using Good Utility Practice to schedule the reduction or disconnection during periods of least impact to the Interconnection Customer and the CAISO and Participating TO. Any reduction or disconnection shall continue only for so long as reasonably necessary under Good Utility Practice. The Parties shall cooperate with each other to restore the Large Generating Facility, the Interconnection Facilities, and the CAISO Controlled Grid to their normal operating state as soon as practicable consistent with Good Utility Practice.

13.6 Interconnection Customer Authority. Consistent with Good Utility Practice, this LGIA, and the CAISO Tariff, the Interconnection Customer may take actions or inactions with regard to the Large Generating Facility or the Interconnection Customer's Interconnection Facilities during an Emergency Condition in order to (i) preserve public health and safety, (ii) preserve the reliability of the Large Generating Facility or the Interconnection Customer's Interconnection Facilities, (iii) limit or prevent damage, and (iv) expedite restoration of service. Interconnection Customer shall use Reasonable Efforts to minimize the effect of such actions or inactions on the CAISO Controlled Grid and the Participating TO's Interconnection Facilities. The CAISO and Participating TO shall use Reasonable Efforts to assist Interconnection Customer in such actions.

13.7 Limited Liability. Except as otherwise provided in Article 11.6.1 of this LGIA, no Party shall be liable to any other Party for any action it takes in responding to an Emergency Condition so long as such action is made in good faith and is consistent with Good Utility Practice.

ARTICLE 14. REGULATORY REQUIREMENTS AND GOVERNING LAW

14.1 Regulatory Requirements. Each Party's obligations under this LGIA shall be subject to its receipt of any required approval or certificate from one or more Governmental Authorities in the form and substance satisfactory to the applying

Party, or the Party making any required filings with, or providing notice to, such Governmental Authorities, and the expiration of any time period associated therewith. Each Party shall in good faith seek and use its Reasonable Efforts to obtain such other approvals. Nothing in this LGIA shall require the Interconnection Customer to take any action that could result in its inability to obtain, or its loss of, status or exemption under the Federal Power Act or the Public Utility Holding Company Act of 1935, as amended, or the Public Utility Regulatory Policies Act of 1978, or the Energy Policy Act of 2005.

14.2 Governing Law.

14.2.1 The validity, interpretation and performance of this LGIA and each of its provisions shall be governed by the laws of the state where the Point of Interconnection is located, without regard to its conflicts of law principles.

14.2.2 This LGIA is subject to all Applicable Laws and Regulations.

14.2.3 Each Party expressly reserves the right to seek changes in, appeal, or otherwise contest any laws, orders, rules, or regulations of a Governmental Authority.

ARTICLE 15. NOTICES

15.1 General. Unless otherwise provided in this LGIA, any notice, demand or request required or permitted to be given by a Party to another and any instrument required or permitted to be tendered or delivered by a Party in writing to another shall be effective when delivered and may be so given, tendered or delivered, by recognized national courier, or by depositing the same with the United States Postal Service with postage prepaid, for delivery by certified or registered mail, addressed to the Party, or personally delivered to the Party, at the address set out in Appendix F, Addresses for Delivery of Notices and Billings.

A Party must update the information in Appendix F as information changes. A Party may change the notice information in this LGIA by giving five (5) Business Days written notice prior to the effective date of the change. Such changes shall not constitute an amendment to this LGIA.

15.2 Billings and Payments. Billings and payments shall be sent to the addresses set out in Appendix F.

15.3 Alternative Forms of Notice. Any notice or request required or permitted to be given by a Party to another and not required by this LGIA to be given in writing may be so given by telephone, facsimile or e-mail to the telephone numbers and e-mail addresses set out in Appendix F.

15.4 Operations and Maintenance Notice. Each Party shall notify the other Parties in writing of the identity of the person(s) that it designates as the point(s) of contact with respect to the implementation of Articles 9 and 10.

ARTICLE 16. FORCE MAJEURE

16.1 Force Majeure.

16.1.1 Economic hardship is not considered a Force Majeure event.

16.1.2 No Party shall be considered to be in Default with respect to any obligation hereunder, (including obligations under Article 4), other than the obligation to pay money when due, if prevented from fulfilling such obligation by Force Majeure. A Party unable to fulfill any obligation hereunder (other than an obligation to pay money when due) by reason of Force Majeure shall give notice and the full particulars of such Force Majeure to the other Party in writing or by telephone as soon as reasonably possible after the occurrence of the cause relied upon. Telephone notices given pursuant to this Article shall be confirmed in writing as soon as reasonably possible and shall specifically state full particulars of the Force Majeure, the time and date when the Force Majeure occurred and when the Force Majeure is reasonably expected to cease. The Party affected shall exercise due diligence to remove such disability with reasonable dispatch, but shall not be required to accede or agree to any provision not satisfactory to it in order to settle and terminate a strike or other labor disturbance.

ARTICLE 17. DEFAULT

17.1 Default.

17.1.1 General. No Default shall exist where such failure to discharge an obligation (other than the payment of money) is the result of Force Majeure as defined in this LGIA or the result of an act or omission of the other Party. Upon a Breach, the affected non-Breaching Party(ies) shall give written notice of such Breach to the Breaching Party. Except as provided in Article 17.1.2, the Breaching Party shall have thirty (30) Calendar Days from receipt of the Default notice within which to cure such Breach; provided however, if such Breach is not capable of cure within thirty (30) Calendar Days, the Breaching Party shall commence such cure within thirty (30) Calendar Days after notice and continuously and diligently complete such cure within ninety (90) Calendar Days from receipt of the Default notice; and, if cured within such time, the Breach specified in such notice shall cease to exist.

17.1.2 Right to Terminate. If a Breach is not cured as provided in this Article, or if a Breach is not capable of being cured within the period provided for herein, the affected non-Breaching Party(ies) shall have the right to declare a Default and terminate this LGIA by written notice at any time until cure occurs, and be relieved of any further obligation hereunder and, whether or not such Party(ies) terminates this LGIA, to recover from the Breaching Party all amounts due hereunder, plus all other damages and remedies to which it is entitled at law or in equity. The provisions of this Article will survive termination of this LGIA.

ARTICLE 18. INDEMNITY, CONSEQUENTIAL DAMAGES AND INSURANCE

18.1 Indemnity. Each Party shall at all times indemnify, defend, and hold the other Parties harmless from, any and all Losses arising out of or resulting from another Party's action or inactions of its obligations under this LGIA on behalf of the indemnifying Party, except in cases of gross negligence or intentional wrongdoing by the Indemnified Party.

18.1.1 Indemnified Party. If an Indemnified Party is entitled to indemnification under this Article 18 as a result of a claim by a third party, and the Indemnifying Party fails, after notice and reasonable opportunity to proceed under Article 18.1, to assume the defense of such claim, such Indemnified Party may at the expense of the Indemnifying Party contest, settle or consent to the entry of any judgment with respect to, or pay in full, such claim.

18.1.2 Indemnifying Party. If an Indemnifying Party is obligated to indemnify and hold any Indemnified Party harmless under this Article 18, the amount owing to the Indemnified Party shall be the amount of such Indemnified Party's actual Loss, net of any insurance or other recovery.

18.1.3 Indemnity Procedures. Promptly after receipt by an Indemnified Party of any claim or notice of the commencement of any action or administrative or legal proceeding or investigation as to which the indemnity provided for in Article 18.1 may apply, the Indemnified Party shall notify the Indemnifying Party of such fact. Any failure of or delay in such notification shall not affect a Party's indemnification obligation unless such failure or delay is materially prejudicial to the indemnifying Party.

The Indemnifying Party shall have the right to assume the defense thereof with counsel designated by such Indemnifying Party and reasonably satisfactory to the Indemnified Party. If the defendants in any such action include one or more Indemnified Parties and the Indemnifying Party and if the Indemnified Party reasonably concludes that there may

be legal defenses available to it and/or other Indemnified Parties which are different from or additional to those available to the Indemnifying Party, the Indemnified Party shall have the right to select separate counsel to assert such legal defenses and to otherwise participate in the defense of such action on its own behalf. In such instances, the Indemnifying Party shall only be required to pay the fees and expenses of one additional attorney to represent an Indemnified Party or Indemnified Parties having such differing or additional legal defenses.

The Indemnified Party shall be entitled, at its expense, to participate in any such action, suit or proceeding, the defense of which has been assumed by the Indemnifying Party. Notwithstanding the foregoing, the Indemnifying Party (i) shall not be entitled to assume and control the defense of any such action, suit or proceedings if and to the extent that, in the opinion of the Indemnified Party and its counsel, such action, suit or proceeding involves the potential imposition of criminal liability on the Indemnified Party, or there exists a conflict or adversity of interest between the Indemnified Party and the Indemnifying Party, in such event the Indemnifying Party shall pay the reasonable expenses of the Indemnified Party, and (ii) shall not settle or consent to the entry of any judgment in any action, suit or proceeding without the consent of the Indemnified Party, which shall not be unreasonably withheld, conditioned or delayed.

18.2 Consequential Damages. Other than the liquidated damages heretofore described in Article 5.3, in no event shall any Party be liable under any provision of this LGIA for any losses, damages, costs or expenses for any special, indirect, incidental, consequential, or punitive damages, including but not limited to loss of profit or revenue, loss of the use of equipment, cost of capital, cost of temporary equipment or services, whether based in whole or in part in contract, in tort, including negligence, strict liability, or any other theory of liability; provided, however, that damages for which a Party may be liable to another Party under another agreement will not be considered to be special, indirect, incidental, or consequential damages hereunder.

18.3 Insurance. Each Party shall, at its own expense, maintain in force throughout the period of this LGIA, and until released by the other Parties, the following minimum insurance coverages, with insurers rated no less than A- (with a minimum size rating of VII) by Bests' Insurance Guide and Key Ratings and authorized to do business in the state where the Point of Interconnection is located, except in the case of the CAISO, the State of California:

18.3.1 Employer's Liability and Workers' Compensation Insurance providing statutory benefits in accordance with the laws and regulations of the state in which the Point of Interconnection is located, except in the case of the CAISO, the State of California.

- 18.3.2** Commercial General Liability Insurance including premises and operations, personal injury, broad form property damage, broad form blanket contractual liability coverage (including coverage for the contractual indemnification) products and completed operations coverage, coverage for explosion, collapse and underground hazards, independent contractors coverage, coverage for pollution to the extent normally available and punitive damages to the extent normally available and a cross liability endorsement, with minimum limits of One Million Dollars (\$1,000,000) per occurrence/One Million Dollars (\$1,000,000) aggregate combined single limit for personal injury, bodily injury, including death and property damage.
- 18.3.3** Business Automobile Liability Insurance for coverage of owned and non-owned and hired vehicles, trailers or semi-trailers designed for travel on public roads, with a minimum, combined single limit of One Million Dollars (\$1,000,000) per occurrence for bodily injury, including death, and property damage.
- 18.3.4** Excess Public Liability Insurance over and above the Employer's Liability Commercial General Liability and Business Automobile Liability Insurance coverage, with a minimum combined single limit of Twenty Million Dollars (\$20,000,000) per occurrence/Twenty Million Dollars (\$20,000,000) aggregate.
- 18.3.5** The Commercial General Liability Insurance, Business Automobile Insurance and Excess Public Liability Insurance policies shall name the other Parties, their parents, associated and Affiliate companies and their respective directors, officers, agents, servants and employees ("Other Party Group") as additional insured. All policies shall contain provisions whereby the insurers waive all rights of subrogation in accordance with the provisions of this LGIA against the Other Party Group and provide thirty (30) Calendar Days advance written notice to the Other Party Group prior to anniversary date of cancellation or any material change in coverage or condition.
- 18.3.6** The Commercial General Liability Insurance, Business Automobile Liability Insurance and Excess Public Liability Insurance policies shall contain provisions that specify that the policies are primary and shall apply to such extent without consideration for other policies separately carried and shall state that each insured is provided coverage as though a separate policy had been issued to each, except the insurer's liability shall not be increased beyond the amount for which the insurer would have been liable had only one insured been covered. Each Party shall be responsible for its respective deductibles or retentions.

- 18.3.7** The Commercial General Liability Insurance, Business Automobile Liability Insurance and Excess Public Liability Insurance policies, if written on a Claims First Made Basis, shall be maintained in full force and effect for two (2) years after termination of this LGIA, which coverage may be in the form of tail coverage or extended reporting period coverage if agreed by the Parties.
- 18.3.8** The requirements contained herein as to the types and limits of all insurance to be maintained by the Parties are not intended to and shall not in any manner, limit or qualify the liabilities and obligations assumed by the Parties under this LGIA.
- 18.3.9** Within ten (10) Calendar Days following execution of this LGIA, and as soon as practicable after the end of each fiscal year or at the renewal of the insurance policy and in any event within ninety (90) Calendar Days thereafter, each Party shall provide certification of all insurance required in this LGIA, executed by each insurer or by an authorized representative of each insurer.
- 18.3.10** Notwithstanding the foregoing, each Party may self-insure to meet the minimum insurance requirements of Articles 18.3.2 through 18.3.8 to the extent it maintains a self-insurance program; provided that, such Party's senior unsecured debt or issuer rating is BBB-, or better, as rated by Standard & Poor's and that its self-insurance program meets the minimum insurance requirements of Articles 18.3.2 through 18.3.8. For any period of time that a Party's senior unsecured debt rating and issuer rating are both unrated by Standard & Poor's or are both rated at less than BBB- by Standard & Poor's, such Party shall comply with the insurance requirements applicable to it under Articles 18.3.2 through 18.3.9. In the event that a Party is permitted to self-insure pursuant to this Article 18.3.10, it shall notify the other Parties that it meets the requirements to self-insure and that its self-insurance program meets the minimum insurance requirements in a manner consistent with that specified in Article 18.3.9.
- 18.3.11** The Parties agree to report to each other in writing as soon as practical all accidents or occurrences resulting in injuries to any person, including death, and any property damage arising out of this LGIA.

ARTICLE 19. ASSIGNMENT

- 19.1 Assignment.** This LGIA may be assigned by a Party only with the written consent of the other Parties; provided that a Party may assign this LGIA without the consent of the other Parties to any Affiliate of the assigning Party with an equal or greater credit rating and with the legal authority and operational ability to

satisfy the obligations of the assigning Party under this LGIA; and provided further that the Interconnection Customer shall have the right to assign this LGIA, without the consent of the CAISO or Participating TO, for collateral security purposes to aid in providing financing for the Large Generating Facility, provided that the Interconnection Customer will promptly notify the CAISO and Participating TO of any such assignment. Any financing arrangement entered into by the Interconnection Customer pursuant to this Article will provide that prior to or upon the exercise of the secured party's, trustee's or mortgagee's assignment rights pursuant to said arrangement, the secured creditor, the trustee or mortgagee will notify the CAISO and Participating TO of the date and particulars of any such exercise of assignment right(s), including providing the CAISO and Participating TO with proof that it meets the requirements of Articles 11.5 and 18.3. Any attempted assignment that violates this Article is void and ineffective. Any assignment under this LGIA shall not relieve a Party of its obligations, nor shall a Party's obligations be enlarged, in whole or in part, by reason thereof. Where required, consent to assignment will not be unreasonably withheld, conditioned or delayed.

ARTICLE 20. SEVERABILITY

- 20.1 Severability.** If any provision in this LGIA is finally determined to be invalid, void or unenforceable by any court or other Governmental Authority having jurisdiction, such determination shall not invalidate, void or make unenforceable any other provision, agreement or covenant of this LGIA; provided that if the Interconnection Customer (or any third party, but only if such third party is not acting at the direction of the Participating TO or CAISO) seeks and obtains such a final determination with respect to any provision of the Alternate Option (Article 5.1.2), or the Negotiated Option (Article 5.1.4), then none of the provisions of Article 5.1.2 or 5.1.4 shall thereafter have any force or effect and the Parties' rights and obligations shall be governed solely by the Standard Option (Article 5.1.1).

ARTICLE 21. COMPARABILITY

- 21.1 Comparability.** The Parties will comply with all applicable comparability and code of conduct laws, rules and regulations, as amended from time to time.

ARTICLE 22. CONFIDENTIALITY

22.1 Confidentiality. Confidential Information shall include, without limitation, all information relating to a Party's technology, research and development, business affairs, and pricing, and any information supplied by any of the Parties to the other Parties prior to the execution of this LGIA.

Information is Confidential Information only if it is clearly designated or marked in writing as confidential on the face of the document, or, if the information is conveyed orally or by inspection, if the Party providing the information orally informs the Parties receiving the information that the information is confidential.

If requested by any Party, the other Parties shall provide in writing, the basis for asserting that the information referred to in this Article 22 warrants confidential treatment, and the requesting Party may disclose such writing to the appropriate Governmental Authority. Each Party shall be responsible for the costs associated with affording confidential treatment to its information.

22.1.1 Term. During the term of this LGIA, and for a period of three (3) years after the expiration or termination of this LGIA, except as otherwise provided in this Article 22, each Party shall hold in confidence and shall not disclose to any person Confidential Information.

22.1.2 Scope. Confidential Information shall not include information that the receiving Party can demonstrate: (1) is generally available to the public other than as a result of a disclosure by the receiving Party; (2) was in the lawful possession of the receiving Party on a non-confidential basis before receiving it from the disclosing Party; (3) was supplied to the receiving Party without restriction by a third party, who, to the knowledge of the receiving Party after due inquiry, was under no obligation to the disclosing Party to keep such information confidential; (4) was independently developed by the receiving Party without reference to Confidential Information of the disclosing Party; (5) is, or becomes, publicly known, through no wrongful act or omission of the receiving Party or Breach of this LGIA; or (6) is required, in accordance with Article 22.1.7 of this LGIA, Order of Disclosure, to be disclosed by any Governmental Authority or is otherwise required to be disclosed by law or subpoena, or is necessary in any legal proceeding establishing rights and obligations under this LGIA. Information designated as Confidential Information will no longer be deemed confidential if the Party that designated the information as confidential notifies the other Parties that it no longer is confidential.

22.1.3 Release of Confidential Information. No Party shall release or disclose Confidential Information to any other person, except to its employees, consultants, Affiliates (limited by the Standards of Conduct requirements

set forth in Part 358 of FERC's Regulations, 18 C.F.R. 358), subcontractors, or to parties who may be or considering providing financing to or equity participation with the Interconnection Customer, or to potential purchasers or assignees of the Interconnection Customer, on a need-to-know basis in connection with this LGIA, unless such person has first been advised of the confidentiality provisions of this Article 22 and has agreed to comply with such provisions. Notwithstanding the foregoing, a Party providing Confidential Information to any person shall remain primarily responsible for any release of Confidential Information in contravention of this Article 22.

22.1.4 Rights. Each Party retains all rights, title, and interest in the Confidential Information that each Party discloses to the other Parties. The disclosure by each Party to the other Parties of Confidential Information shall not be deemed a waiver by a Party or any other person or entity of the right to protect the Confidential Information from public disclosure.

22.1.5 No Warranties. The mere fact that a Party has provided Confidential Information does not constitute a warranty or representation as to its accuracy or completeness. In addition, by supplying Confidential Information, no Party obligates itself to provide any particular information or Confidential Information to the other Parties nor to enter into any further agreements or proceed with any other relationship or joint venture.

22.1.6 Standard of Care. Each Party shall use at least the same standard of care to protect Confidential Information it receives as it uses to protect its own Confidential Information from unauthorized disclosure, publication or dissemination. Each Party may use Confidential Information solely to fulfill its obligations to the other Parties under this LGIA or its regulatory requirements.

22.1.7 Order of Disclosure. If a court or a Government Authority or entity with the right, power, and apparent authority to do so requests or requires any Party, by subpoena, oral deposition, interrogatories, requests for production of documents, administrative order, or otherwise, to disclose Confidential Information, that Party shall provide the other Parties with prompt notice of such request(s) or requirement(s) so that the other Parties may seek an appropriate protective order or waive compliance with the terms of this LGIA. Notwithstanding the absence of a protective order or waiver, the Party may disclose such Confidential Information which, in the opinion of its counsel, the Party is legally compelled to disclose. Each Party will use Reasonable Efforts to obtain reliable assurance that confidential treatment will be accorded any Confidential Information so furnished.

22.1.8 Termination of Agreement. Upon termination of this LGIA for any reason, each Party shall, within ten (10) Calendar Days of receipt of a written request from another Party, use Reasonable Efforts to destroy, erase, or delete (with such destruction, erasure, and deletion certified in writing to the other Party) or return to the other Party, without retaining copies thereof, any and all written or electronic Confidential Information received from the other Party.

22.1.9 Remedies. The Parties agree that monetary damages would be inadequate to compensate a Party for another Party's Breach of its obligations under this Article 22. Each Party accordingly agrees that the other Parties shall be entitled to equitable relief, by way of injunction or otherwise, if the first Party Breaches or threatens to Breach its obligations under this Article 22, which equitable relief shall be granted without bond or proof of damages, and the receiving Party shall not plead in defense that there would be an adequate remedy at law. Such remedy shall not be deemed an exclusive remedy for the Breach of this Article 22, but shall be in addition to all other remedies available at law or in equity. The Parties further acknowledge and agree that the covenants contained herein are necessary for the protection of legitimate business interests and are reasonable in scope. No Party, however, shall be liable for indirect, incidental, or consequential or punitive damages of any nature or kind resulting from or arising in connection with this Article 22.

22.1.10 Disclosure to FERC, its Staff, or a State. Notwithstanding anything in this Article 22 to the contrary, and pursuant to 18 C.F.R. section 1b.20, if FERC or its staff, during the course of an investigation or otherwise, requests information from one of the Parties that is otherwise required to be maintained in confidence pursuant to this LGIA, the Party shall provide the requested information to FERC or its staff, within the time provided for in the request for information. In providing the information to FERC or its staff, the Party must, consistent with 18 C.F.R. section 388.112, request that the information be treated as confidential and non-public by FERC and its staff and that the information be withheld from public disclosure. Parties are prohibited from notifying the other Parties to this LGIA prior to the release of the Confidential Information to FERC or its staff. The Party shall notify the other Parties to the LGIA when it is notified by FERC or its staff that a request to release Confidential Information has been received by FERC, at which time any of the Parties may respond before such information would be made public, pursuant to 18 C.F.R. section 388.112. Requests from a state regulatory body conducting a confidential investigation shall be treated in a similar manner if consistent with the applicable state rules and regulations.

22.1.11 Subject to the exception in Article 22.1.10, Confidential Information shall not be disclosed by the other Parties to any person not employed or

retained by the other Parties, except to the extent disclosure is (i) required by law; (ii) reasonably deemed by the disclosing Party to be required to be disclosed in connection with a dispute between or among the Parties, or the defense of litigation or dispute; (iii) otherwise permitted by consent of the other Parties, such consent not to be unreasonably withheld; or (iv) necessary to fulfill its obligations under this LGIA or as a transmission service provider or a Balancing Authority including disclosing the Confidential Information to an RTO or ISO or to a regional or national reliability organization. The Party asserting confidentiality shall notify the other Parties in writing of the information it claims is confidential. Prior to any disclosures of another Party's Confidential Information under this subparagraph, or if any third party or Governmental Authority makes any request or demand for any of the information described in this subparagraph, the disclosing Party agrees to promptly notify the other Party in writing and agrees to assert confidentiality and cooperate with the other Party in seeking to protect the Confidential Information from public disclosure by confidentiality agreement, protective order or other reasonable measures.

ARTICLE 23. ENVIRONMENTAL RELEASES

- 23.1** Each Party shall notify the other Parties, first orally and then in writing, of the release of any Hazardous Substances, any asbestos or lead abatement activities, or any type of remediation activities related to the Large Generating Facility or the Interconnection Facilities, each of which may reasonably be expected to affect the other Parties. The notifying Party shall: (i) provide the notice as soon as practicable, provided such Party makes a good faith effort to provide the notice no later than twenty-four hours after such Party becomes aware of the occurrence; and (ii) promptly furnish to the other Parties copies of any publicly available reports filed with any Governmental Authorities addressing such events.

ARTICLE 24. INFORMATION REQUIREMENTS

- 24.1 Information Acquisition.** The Participating TO and the Interconnection Customer shall submit specific information regarding the electrical characteristics of their respective facilities to each other as described below and in accordance with Applicable Reliability Standards.
- 24.2 Information Submission by Participating TO.** The initial information submission by the Participating TO shall occur no later than one hundred eighty (180) Calendar Days prior to Trial Operation and shall include the Participating TO's Transmission System information necessary to allow the Interconnection Customer to select equipment and meet any system protection and stability

requirements, unless otherwise agreed to by the Participating TO and the Interconnection Customer. On a monthly basis the Participating TO shall provide the Interconnection Customer and the CAISO a status report on the construction and installation of the Participating TO's Interconnection Facilities and Network Upgrades, including, but not limited to, the following information: (1) progress to date; (2) a description of the activities since the last report; (3) a description of the action items for the next period; and (4) the delivery status of equipment ordered.

24.3 Updated Information Submission by Interconnection Customer. The updated information submission by the Interconnection Customer, including manufacturer information, shall occur no later than one hundred eighty (180) Calendar Days prior to the Trial Operation. The Interconnection Customer shall submit a completed copy of the Electric Generating Unit data requirements contained in Appendix 1 to the LGIP. It shall also include any additional information provided to the Participating TO and the CAISO for the Interconnection Studies. Information in this submission shall be the most current Electric Generating Unit design or expected performance data. Information submitted for stability models shall be compatible with the Participating TO and CAISO standard models. If there is no compatible model, the Interconnection Customer will work with a consultant mutually agreed to by the Parties to develop and supply a standard model and associated information.

If the Interconnection Customer's data is materially different from what was originally provided to the Participating TO and the CAISO for the Interconnection Studies, then the Participating TO and the CAISO will conduct appropriate studies pursuant to the LGIP to determine the impact on the Participating TO's Transmission System and affected portions of the CAISO Controlled Grid based on the actual data submitted pursuant to this Article 24.3. The Interconnection Customer shall not begin Trial Operation until such studies are completed and all other requirements of this LGIA are satisfied.

24.4 Information Supplementation. Prior to the Trial Operation date, the Parties shall supplement their information submissions described above in this Article 24 with any and all "as-built" Electric Generating Unit information or "as-tested" performance information that differs from the initial submissions or, alternatively, written confirmation that no such differences exist. The Interconnection Customer shall conduct tests on the Electric Generating Unit as required by Good Utility Practice such as an open circuit "step voltage" test on the Electric Generating Unit to verify proper operation of the Electric Generating Unit's automatic voltage regulator.

Unless otherwise agreed, the test conditions shall include: (1) Electric Generating Unit at synchronous speed; (2) automatic voltage regulator on and in voltage control mode; and (3) a five percent (5 percent) change in Electric Generating Unit terminal voltage initiated by a change in the voltage regulators reference

voltage. The Interconnection Customer shall provide validated test recordings showing the responses of Electric Generating Unit terminal and field voltages. In the event that direct recordings of these voltages is impractical, recordings of other voltages or currents that mirror the response of the Electric Generating Unit's terminal or field voltage are acceptable if information necessary to translate these alternate quantities to actual Electric Generating Unit terminal or field voltages is provided. Electric Generating Unit testing shall be conducted and results provided to the Participating TO and the CAISO for each individual Electric Generating Unit in a station.

Subsequent to the Commercial Operation Date, the Interconnection Customer shall provide the Participating TO and the CAISO any information changes due to equipment replacement, repair, or adjustment. The Participating TO shall provide the Interconnection Customer any information changes due to equipment replacement, repair or adjustment in the directly connected substation or any adjacent Participating TO-owned substation that may affect the Interconnection Customer's Interconnection Facilities equipment ratings, protection or operating requirements. The Parties shall provide such information pursuant to Article 5.19.

ARTICLE 25. INFORMATION ACCESS AND AUDIT RIGHTS

- 25.1 Information Access.** Each Party (the "disclosing Party") shall make available to the other Party information that is in the possession of the disclosing Party and is necessary in order for the other Party to: (i) verify the costs incurred by the disclosing Party for which the other Party is responsible under this LGIA; and (ii) carry out its obligations and responsibilities under this LGIA. The Parties shall not use such information for purposes other than those set forth in this Article 25.1 and to enforce their rights under this LGIA. Nothing in this Article 25 shall obligate the CAISO to make available to a Party any third party information in its possession or control if making such third party information available would violate a CAISO Tariff restriction on the use or disclosure of such third party information.
- 25.2 Reporting of Non-Force Majeure Events.** Each Party (the "notifying Party") shall notify the other Parties when the notifying Party becomes aware of its inability to comply with the provisions of this LGIA for a reason other than a Force Majeure event. The Parties agree to cooperate with each other and provide necessary information regarding such inability to comply, including the date, duration, reason for the inability to comply, and corrective actions taken or planned to be taken with respect to such inability to comply. Notwithstanding the foregoing, notification, cooperation or information provided under this Article shall not entitle the Party receiving such notification to allege a cause for anticipatory breach of this LGIA.

25.3 Audit Rights. Subject to the requirements of confidentiality under Article 22 of this LGIA, the Parties' audit rights shall include audits of a Party's costs pertaining to such Party's performance or satisfaction of obligations owed to the other Party under this LGIA, calculation of invoiced amounts, the CAISO's efforts to allocate responsibility for the provision of reactive support to the CAISO Controlled Grid, the CAISO's efforts to allocate responsibility for interruption or reduction of generation on the CAISO Controlled Grid, and each such Party's actions in an Emergency Condition.

25.3.1 The Interconnection Customer and the Participating TO shall each have the right, during normal business hours, and upon prior reasonable notice to the other Party, to audit at its own expense the other Party's accounts and records pertaining to either such Party's performance or either such Party's satisfaction of obligations owed to the other Party under this LGIA. Subject to Article 25.3.2, any audit authorized by this Article shall be performed at the offices where such accounts and records are maintained and shall be limited to those portions of such accounts and records that relate to each such Party's performance and satisfaction of obligations under this LGIA. Each such Party shall keep such accounts and records for a period equivalent to the audit rights periods described in Article 25.4.

25.3.2 Notwithstanding anything to the contrary in Article 25.3, each Party's rights to audit the CAISO's accounts and records shall be as set forth in Section 22.1 of the CAISO Tariff.

25.4 Audit Rights Periods.

25.4.1 Audit Rights Period for Construction-Related Accounts and Records.

Accounts and records related to the design, engineering, procurement, and construction of Participating TO's Interconnection Facilities, Network Upgrades, and Distribution Upgrades constructed by the Participating TO shall be subject to audit for a period of twenty-four months following the Participating TO's issuance of a final invoice in accordance with Article 12.2. Accounts and records related to the design, engineering, procurement, and construction of Participating TO's Interconnection Facilities and/or Stand Alone Network Upgrades constructed by the Interconnection Customer shall be subject to audit and verification by the Participating TO and the CAISO for a period of twenty-four months following the Interconnection Customer's issuance of a final invoice in accordance with Article 5.2(8).

25.4.2 Audit Rights Period for All Other Accounts and Records. Accounts and records related to a Party's performance or satisfaction of all obligations under this LGIA other than those described in Article 25.4.1 shall be subject to audit as follows: (i) for an audit relating to cost obligations, the applicable audit rights period shall be twenty-four months

after the auditing Party's receipt of an invoice giving rise to such cost obligations; and (ii) for an audit relating to all other obligations, the applicable audit rights period shall be twenty-four months after the event for which the audit is sought; provided that each Party's rights to audit the CAISO's accounts and records shall be as set forth in Section 22.1 of the CAISO Tariff.

25.5 Audit Results. If an audit by the Interconnection Customer or the Participating TO determines that an overpayment or an underpayment has occurred with respect to the other Party, a notice of such overpayment or underpayment shall be given to the other Party together with those records from the audit which supports such determination. The Party that is owed payment shall render an invoice to the other Party and such invoice shall be paid pursuant to Article 12 hereof.

25.5.1 Notwithstanding anything to the contrary in Article 25.5, the Interconnection Customer's and Participating TO's rights to audit the CAISO's accounts and records shall be as set forth in Section 22.1 of the CAISO Tariff, and the CAISO's process for remedying an overpayment or underpayment shall be as set forth in the CAISO Tariff.

ARTICLE 26. SUBCONTRACTORS

26.1 General. Nothing in this LGIA shall prevent a Party from utilizing the services of any subcontractor as it deems appropriate to perform its obligations under this LGIA; provided, however, that each Party shall require its subcontractors to comply with all applicable terms and conditions of this LGIA in providing such services and each Party shall remain primarily liable to the other Party for the performance of such subcontractor.

26.2 Responsibility of Principal. The creation of any subcontract relationship shall not relieve the hiring Party of any of its obligations under this LGIA. The hiring Party shall be fully responsible to the other Parties for the acts or omissions of any subcontractor the hiring Party hires as if no subcontract had been made; provided, however, that in no event shall the CAISO or Participating TO be liable for the actions or inactions of the Interconnection Customer or its subcontractors with respect to obligations of the Interconnection Customer under Article 5 of this LGIA. Any applicable obligation imposed by this LGIA upon the hiring Party shall be equally binding upon, and shall be construed as having application to, any subcontractor of such Party.

26.3 No Limitation by Insurance. The obligations under this Article 26 will not be limited in any way by any limitation of subcontractor's insurance.

ARTICLE 27. DISPUTES

All disputes arising out of or in connection with this LGIA whereby relief is sought by or from the CAISO shall be settled in accordance with the provisions of Article 13 of the CAISO Tariff, except that references to the CAISO Tariff in such Article 13 of the CAISO Tariff shall be read as references to this LGIA. Disputes arising out of or in connection with this LGIA not subject to provisions of Article 13 of the CAISO Tariff shall be resolved as follows:

- 27.1 Submission.** In the event either Party has a dispute, or asserts a claim, that arises out of or in connection with this LGIA or its performance, such Party (the “disputing Party”) shall provide the other Party with written notice of the dispute or claim (“Notice of Dispute”). Such dispute or claim shall be referred to a designated senior representative of each Party for resolution on an informal basis as promptly as practicable after receipt of the Notice of Dispute by the other Party. In the event the designated representatives are unable to resolve the claim or dispute through unassisted or assisted negotiations within thirty (30) Calendar Days of the other Party’s receipt of the Notice of Dispute, such claim or dispute may, upon mutual agreement of the Parties, be submitted to arbitration and resolved in accordance with the arbitration procedures set forth below. In the event the Parties do not agree to submit such claim or dispute to arbitration, each Party may exercise whatever rights and remedies it may have in equity or at law consistent with the terms of this LGIA.
- 27.2 External Arbitration Procedures.** Any arbitration initiated under this LGIA shall be conducted before a single neutral arbitrator appointed by the Parties. If the Parties fail to agree upon a single arbitrator within ten (10) Calendar Days of the submission of the dispute to arbitration, each Party shall choose one arbitrator who shall sit on a three-member arbitration panel. The two arbitrators so chosen shall within twenty (20) Calendar Days select a third arbitrator to chair the arbitration panel. In either case, the arbitrators shall be knowledgeable in electric utility matters, including electric transmission and bulk power issues, and shall not have any current or past substantial business or financial relationships with any party to the arbitration (except prior arbitration). The arbitrator(s) shall provide each of the Parties an opportunity to be heard and, except as otherwise provided herein, shall conduct the arbitration in accordance with the Commercial Arbitration Rules of the American Arbitration Association (“Arbitration Rules”) and any applicable FERC regulations; provided, however, in the event of a conflict between the Arbitration Rules and the terms of this Article 27, the terms of this Article 27 shall prevail.
- 27.3 Arbitration Decisions.** Unless otherwise agreed by the Parties, the arbitrator(s) shall render a decision within ninety (90) Calendar Days of appointment and shall notify the Parties in writing of such decision and the reasons therefor. The arbitrator(s) shall be authorized only to interpret and apply the provisions of this LGIA and shall have no power to modify or change any provision of this

Agreement in any manner. The decision of the arbitrator(s) shall be final and binding upon the Parties, and judgment on the award may be entered in any court having jurisdiction. The decision of the arbitrator(s) may be appealed solely on the grounds that the conduct of the arbitrator(s), or the decision itself, violated the standards set forth in the Federal Arbitration Act or the Administrative Dispute Resolution Act. The final decision of the arbitrator(s) must also be filed with FERC if it affects jurisdictional rates, terms and conditions of service, Interconnection Facilities, or Network Upgrades.

- 27.4 Costs.** Each Party shall be responsible for its own costs incurred during the arbitration process and for the following costs, if applicable: (1) the cost of the arbitrator chosen by the Party to sit on the three member panel and one half of the cost of the third arbitrator chosen; or (2) one half the cost of the single arbitrator jointly chosen by the Parties.

ARTICLE 28. REPRESENTATIONS, WARRANTIES AND COVENANTS

- 28.1 General.** Each Party makes the following representations, warranties and covenants:

28.1.1 Good Standing. Such Party is duly organized, validly existing and in good standing under the laws of the state in which it is organized, formed, or incorporated, as applicable; that it is qualified to do business in the state or states in which the Large Generating Facility, Interconnection Facilities and Network Upgrades owned by such Party, as applicable, are located; and that it has the corporate power and authority to own its properties, to carry on its business as now being conducted and to enter into this LGIA and carry out the transactions contemplated hereby and perform and carry out all covenants and obligations on its part to be performed under and pursuant to this LGIA.

28.1.2 Authority. Such Party has the right, power and authority to enter into this LGIA, to become a Party hereto and to perform its obligations hereunder. This LGIA is a legal, valid and binding obligation of such Party, enforceable against such Party in accordance with its terms, except as the enforceability thereof may be limited by applicable bankruptcy, insolvency, reorganization or other similar laws affecting creditors' rights generally and by general equitable principles (regardless of whether enforceability is sought in a proceeding in equity or at law).

28.1.3 No Conflict. The execution, delivery and performance of this LGIA does not violate or conflict with the organizational or formation documents, or bylaws or operating agreement, of such Party, or any

judgment, license, permit, order, material agreement or instrument applicable to or binding upon such Party or any of its assets.

- 28.1.4 Consent and Approval.** Such Party has sought or obtained, or, in accordance with this LGIA will seek or obtain, each consent, approval, authorization, order, or acceptance by any Governmental Authority in connection with the execution, delivery and performance of this LGIA, and it will provide to any Governmental Authority notice of any actions under this LGIA that are required by Applicable Laws and Regulations.

ARTICLE 29. [RESERVED]

ARTICLE 30. MISCELLANEOUS

- 30.1 Binding Effect.** This LGIA and the rights and obligations hereof, shall be binding upon and shall inure to the benefit of the successors and assigns of the Parties hereto.
- 30.2 Conflicts.** In the event of a conflict between the body of this LGIA and any attachment, appendices or exhibits hereto, the terms and provisions of the body of this LGIA shall prevail and be deemed the final intent of the Parties.
- 30.3 Rules of Interpretation.** This LGIA, unless a clear contrary intention appears, shall be construed and interpreted as follows: (1) the singular number includes the plural number and vice versa; (2) reference to any person includes such person's successors and assigns but, in the case of a Party, only if such successors and assigns are permitted by this LGIA, and reference to a person in a particular capacity excludes such person in any other capacity or individually; (3) reference to any agreement (including this LGIA), document, instrument or tariff means such agreement, document, instrument, or tariff as amended or modified and in effect from time to time in accordance with the terms thereof and, if applicable, the terms hereof; (4) reference to any Applicable Laws and Regulations means such Applicable Laws and Regulations as amended, modified, codified, or reenacted, in whole or in part, and in effect from time to time, including, if applicable, rules and regulations promulgated thereunder; (5) unless expressly stated otherwise, reference to any Article, Section or Appendix means such Article of this LGIA or such Appendix to this LGIA, or such Section to the LGIP or such Appendix to the LGIP, as the case may be; (6) "hereunder", "hereof", "herein", "hereto" and words of similar import shall be deemed references to this LGIA as a whole and not to any particular Article or other provision hereof or thereof; (7) "including" (and with correlative meaning "include") means including without limiting the generality of any description preceding such term; and (8) relative to the determination of any period of time, "from" means "from and including", "to" means "to but excluding" and "through" means "through and including".

30.4 Entire Agreement. This LGIA, including all Appendices and Schedules attached hereto, constitutes the entire agreement among the Parties with reference to the subject matter hereof, and supersedes all prior and contemporaneous understandings or agreements, oral or written, between or among the Parties with respect to the subject matter of this LGIA. There are no other agreements, representations, warranties, or covenants which constitute any part of the consideration for, or any condition to, any Party's compliance with its obligations under this LGIA.

30.5 No Third Party Beneficiaries. This LGIA is not intended to and does not create rights, remedies, or benefits of any character whatsoever in favor of any persons, corporations, associations, or entities other than the Parties, and the obligations herein assumed are solely for the use and benefit of the Parties, their successors in interest and, where permitted, their assigns.

30.6 Waiver. The failure of a Party to this LGIA to insist, on any occasion, upon strict performance of any provision of this LGIA will not be considered a waiver of any obligation, right, or duty of, or imposed upon, such Party.

Any waiver at any time by either Party of its rights with respect to this LGIA shall not be deemed a continuing waiver or a waiver with respect to any other failure to comply with any other obligation, right, duty of this LGIA. Termination or Default of this LGIA for any reason by the Interconnection Customer shall not constitute a waiver of the Interconnection Customer's legal rights to obtain an interconnection from the Participating TO. Any waiver of this LGIA shall, if requested, be provided in writing.

30.7 Headings. The descriptive headings of the various Articles of this LGIA have been inserted for convenience of reference only and are of no significance in the interpretation or construction of this LGIA.

30.8 Multiple Counterparts. This LGIA may be executed in two or more counterparts, each of which is deemed an original but all constitute one and the same instrument.

30.9 Amendment. The Parties may by mutual agreement amend this LGIA by a written instrument duly executed by all of the Parties. Such amendment shall become effective and a part of this LGIA upon satisfaction of all Applicable Laws and Regulations.

30.10 Modification by the Parties. The Parties may by mutual agreement amend the Appendices to this LGIA by a written instrument duly executed by all of the Parties. Such amendment shall become effective and a part of this LGIA upon satisfaction of all Applicable Laws and Regulations.

30.11 Reservation of Rights. The CAISO and Participating TO shall each have the right to make a unilateral filing with FERC to modify this LGIA pursuant to section 205 or any other applicable provision of the Federal Power Act and FERC's rules and regulations thereunder with respect to the following Articles and Appendices of this LGIA and with respect to any rates, terms and conditions, charges, classifications of service, rule or regulation covered by these Articles and Appendices:

Recitals, 1, 2.1, 2.2, 2.3, 2.4, 2.6, 3.1, 3.3, 4.1, 4.2, 4.3, 4.4, 5 preamble, 5.4, 5.7, 5.8, 5.9, 5.12, 5.13, 5.18, 5.19.1, 7.1, 7.2, 8, 9.1, 9.2, 9.3, 9.5, 9.6, 9.7, 9.8, 9.10, 10.3, 11.4, 12.1, 13, 14, 15, 16, 17, 18, 19, 20, 21, 22, 23, 24.3, 24.4, 25.1, 25.2, 25.3 (excluding subparts), 25.4.2, 26, 28, 29, 30, Appendix D, Appendix F, Appendix G, and any other Article not reserved exclusively to the Participating TO or the CAISO below.

The Participating TO shall have the exclusive right to make a unilateral filing with FERC to modify this LGIA pursuant to section 205 or any other applicable provision of the Federal Power Act and FERC's rules and regulations thereunder with respect to the following Articles and Appendices of this LGIA and with respect to any rates, terms and conditions, charges, classifications of service, rule or regulation covered by these Articles and Appendices:

2.5, 5.1, 5.2, 5.3, 5.5, 5.6, 5.10, 5.11, 5.14, 5.15, 5.16, 5.17, 5.19 (excluding 5.19.1), 6, 7.3, 9.4, 9.9, 10.1, 10.2, 10.4, 10.5, 11.1, 11.2, 11.3, 11.5, 12.2, 12.3, 12.4, 24.1, 24.2, 25.3.1, 25.4.1, 25.5 (excluding 25.5.1), 27 (excluding preamble), Appendix A, Appendix B, Appendix C, and Appendix E.

The CAISO shall have the exclusive right to make a unilateral filing with FERC to modify this LGIA pursuant to section 205 or any other applicable provision of the Federal Power Act and FERC's rules and regulations thereunder with respect to the following Articles of this LGIA and with respect to any rates, terms and conditions, charges, classifications of service, rule or regulation covered by these Articles:

3.2, 4.5, 11.6, 25.3.2, 25.5.1, and 27 preamble.

The Interconnection Customer, the CAISO, and the Participating TO shall have the right to make a unilateral filing with FERC to modify this LGIA pursuant to section 206 or any other applicable provision of the Federal Power Act and FERC's rules and regulations thereunder; provided that each Party shall have the right to protest any such filing by another Party and to participate fully in any proceeding before FERC in which such modifications may be considered. Nothing in this LGIA shall limit the rights of the Parties or of FERC under sections 205 or 206 of the Federal Power Act and FERC's rules and regulations

thereunder, except to the extent that the Parties otherwise mutually agree as provided herein.

30.12 No Partnership. This LGIA shall not be interpreted or construed to create an association, joint venture, agency relationship, or partnership among the Parties or to impose any partnership obligation or partnership liability upon any Party. No Party shall have any right, power or authority to enter into any agreement or undertaking for, or act on behalf of, or to act as or be an agent or representative of, or to otherwise bind, another Party.

30.13 Joint and Several Obligations. Except as otherwise provided in this LGIA, the obligations of the CAISO, the Participating TO, and the Interconnection Customer are several, and are neither joint nor joint and several.

IN WITNESS WHEREOF, the Parties have executed this LGIA in multiple originals, each of which shall constitute and be an original effective agreement among the Parties.

AV Solar Ranch 1, LLC

By: Frank DeBora
Title: President
Date: 12/1/10

Southern California Edison Company

By: _____
Title: _____
Date: _____

California Independent System Operator Corporation

By: _____
Title: _____
Date: _____

thereunder, except to the extent that the Parties otherwise mutually agree as provided herein.

30.12 No Partnership. This LGIA shall not be interpreted or construed to create an association, joint venture, agency relationship, or partnership among the Parties or to impose any partnership obligation or partnership liability upon any Party. No Party shall have any right, power or authority to enter into any agreement or undertaking for, or act on behalf of, or to act as or be an agent or representative of, or to otherwise bind, another Party.

30.13 Joint and Several Obligations. Except as otherwise provided in this LGIA, the obligations of the CAISO, the Participating TO, and the Interconnection Customer are several, and are neither joint nor joint and several.

IN WITNESS WHEREOF, the Parties have executed this LGIA in multiple originals, each of which shall constitute and be an original effective agreement among the Parties.

AV Solar Ranch 1, LLC

By: _____

Title: _____

Date: _____

Southern California Edison Company

By:  _____
David Mead

Title: Vice President of Engineering and Technical Services

Date: 12-8-10

California Independent System Operator Corporation

By: _____

Title: _____

Date: _____

Appendices to LGIA

- Appendix A Interconnection Facilities, Network Upgrades and Distribution Upgrades
- Appendix B Milestones
- Appendix C Interconnection Details
- Appendix D Security Arrangements Details
- Appendix E Commercial Operation Date
- Appendix F Addresses for Delivery of Notices and Billings
- Appendix G Interconnection Customer's Proportional Share of Costs of Network Upgrades for Applicable Project Group
- Appendix H Interconnection Requirements For An Asynchronous Generating Facility

Appendix A To LGIA

Interconnection Facilities, Network Upgrades and Distribution Upgrades

The Participating TO's Interconnection Facilities, Network Upgrades and Distribution Upgrades described in this Appendix A to the LGIA are based on the Participating TO's preliminary engineering and design and are subject to modification to reflect the actual facilities that are constructed and installed following the Participating TO's final engineering and design, identification of field conditions, and compliance with applicable environmental and permitting requirements.

1. Interconnection Facilities:

- (a) **Interconnection Customer's Interconnection Facilities:** The Interconnection Customer shall:
- (i) Install a new 220 kV generation tie-line from the Generating Facility to the last structure outside the Whirlwind Substation property line. The Interconnection Customer's generation tie-line right-of-way should extend up to the edge of the Whirlwind Substation property line. This generation tie-line line will be called AV Solar One-Whirlwind 220kV Transmission Line.
 - (ii) Install optical ground wire ("OPGW") on the AV Solar One-Whirlwind 220kV Transmission Line to provide one of the two telecommunication paths required to support the line protection scheme and Remote Terminal Unit ("RTU"). The Interconnection Customer will provide approximately 1,000 feet of optical fiber cable to extend OPGW from the last transmission structure owned by the Interconnection Customer outside of the Whirlwind Substation fence into the communication room at Whirlwind Substation. Participating TO's utility operations shall have exclusive use of eight strands within the OPGW and more than eight strands with the prior written consent of AV Solar.
 - (iii) Make available adequate space and facilities necessary for the installation of the Participating TO's RTU and telecommunication panel to be located at the Generating Facility.
 1. Provide sufficient floor space within a secure building having suitable environmental controls for Participating TO to install and operate one 8' high x19" wide communication equipment rack. This rack will be provided with two dedicated 10-amp branch circuits from the station light and power 125 VDC system.
 2. Provide and bring to the RTU one (1) dedicated 125VDC circuit, one (1) dedicated 115VAC convenient circuit and all station interface wiring.
 3. Provide and install the optical entrance cable from the OPGW to a patch panel in the Participating TO's communications rack at the Large Generating Facility.

- (iv) Install all required CAISO-approved metering equipment at the Generating Facility in accordance with Section 10 of the CAISO Tariff.
- (v) Install all Participating TO-required metering equipment (voltage transformers with an accuracy of .3% and current transformers with an accuracy of .15%) which will be used for retail metering at the Generating Facility.
- (vi) Install a metering cabinet to house the retail meters in a location that provides Participating TO 24-hour access.
- (vii) Install 220kV line protection at the Generating Facility as specified by the Participating TO. This is expected to include the following:
 - 1. One G.E. L90 current differential relay with dual dedicated digital communication channels to the Whirlwind Substation.
 - 2. One SEL 311L current differential relay with dedicated digital communication channel to the Whirlwind Substation that is diverse from the L90 communication channel.
 - 3. One (1) SEL-2407 satellite synchronized clock.

(b) Participating TO's Interconnection Facilities: The Participating TO shall:

(i) AV Solar One-Whirlwind 220 kV Transmission Line:

- 1. Install one 220 kV dead-end structure, two spans of conductors and OPGW and twelve dead end insulator / hardware assemblies between the last Interconnection Customer-owned structure on the AV Solar One-Whirlwind 220 kV Transmission Line and the Whirlwind Substation's dead-end rack at the 220 kV switchyard.

(ii) Whirlwind Substation:

- 1. Install a dedicated double breaker 220 kV line position to terminate the new AV Solar One-Whirlwind 220 kV Transmission Line which will include:
 - a. One 65-foot. high by 50-foot wide dead-end structure
 - b. Three coupling capacitor voltage transformers with steel pedestal support structures
 - c. Three 60-foot line tie-downs with 2-1590 KCMIL ACSR conductors
 - d. One GE L90 line current differential relay with telecommunications channel to the Generating Facility via the AV Solar One-Whirlwind 220 kV Transmission Line's OPGW
 - e. One SEL-311L line current differential relay with telecommunication channel to the Large Generating Facility that is diverse from the L90 communication channel.
- 2. Telecommunications: Install all required light-wave, channel and related terminal equipment to support the AV Solar One-Whirlwind 220 kV Transmission Line protection, SPS, SCADA, and Participating TO's applicable voice and data requirements.

(iii) AV Solar One Generating Facility:

1. Power System Control: Install one (1) RTU at the Generating Facility to transmit generator unit gross MW and MVAR, plant auxiliary load, generator status, generator circuit breaker status, generator terminal voltage, and project net MW and MVAR. Notwithstanding that the RTU will be located on Interconnection Customer's side of the Point of Change of Ownership, Participating TO shall own, operate and maintain the RTU as part of the Participating TO's Interconnection Facilities.
2. Metering Services: Install revenue meters at the Generating Facility required for metering the retail load at the Generating Facility. Notwithstanding that the metering will be located on the Interconnection Customer's side of the Point of Change of Ownership, Participating TO shall own, operate and maintain the metering as part of the Participating TO's Interconnection Facilities.
3. Telecommunications: Install all required light-wave, channel and related terminal equipment to support the AV Solar One-Whirlwind 220 kV Transmission Line protection and SPS. Notwithstanding that the telecommunications terminal equipment will be located on the Interconnection Customer's side of the Point of Change of Ownership, Participating TO shall own, operate and maintain the telecommunications terminal equipment as part of the Participating TO's Interconnection Facilities.

(iv) Real Properties, Transmission Project Licensing, and Environmental Health and Safety:

Perform all required functions to obtain easements and/or acquire land, obtain licensing and permits, and perform all required environmental activities for the installation of the approximately 25,000 feet of telecommunication route between the Generating Facility and the Whirlwind Substation and the Participating TO's portion of the AV Solar One-Whirlwind 220 kV Transmission Line.

(v) Telecommunications:

1. Install approximately 25,000 feet of 48 strand single mode fiber optic cable from the Whirlwind Substation to the Generating Facility currently planned over existing SCE distribution lines (as currently envisioned).
2. Install approximately 2,000 feet of 1-5" conduit.
3. Install underground vaults, risers, conduits and cable as required to complete all terminations.
4. Install approximately 1,000 feet of optical fiber cable (as provided by the Interconnection Customer in Section 1.a.(ii) of this Appendix A) to extend the OPGW from the first Interconnection Customer-owned transmission structure outside of the Whirlwind Substation fence into the communication room at Whirlwind Substation.

2. Network Upgrades:

(a) **Stand Alone Network Upgrades:** None.

(b) **Other Network Upgrades:**

(i) **Participating TO's Reliability Network Upgrades:**

1. **Whirlwind Substation:** The Participating TO shall:

Equip one 220 kV position at Whirlwind Substation to terminate the generation tie-line. Install the following equipment at the 220 kV Switchyard:

- a. Two 3000A – 63kA circuit breakers
- b. Four 3000A – 80kA horizontal-mounted group-operated disconnect switches
- c. One grounding switch attachment (for lines grounding)
- d. Eighteen bus supports with associated steel pedestals

2. **Other Reliability Network Upgrades:** The Participating TO shall:

- a. Install a Whirlwind AA-bank N-1 SPS
- b. Install a Whirlwind 220 kV bus extension
- c. Install short-circuit duty (“SCD”) mitigation:
Replace seven circuit breakers and upgrade four circuit breakers to achieve 63 kA rating on overstressed Vincent 500 kV circuit breakers.
- d. Power System Controls: Add points at Whirlwind Substation and upgrade existing RTU.

(ii) **Participating TO's Delivery Network Upgrades:**

- a. **Whirlwind Substation:** The Participating TO shall install the Whirlwind 2nd and 3rd (3AA and 4AA) transformer banks.

3. **Distribution Upgrades:** None

4. Not Used

5. **Point of Change of Ownership:**

(a) AV Solar One-Whirlwind 220 kV Transmission Line: The Point of Change of Ownership shall be the point where the conductors of the AV Solar One-Whirlwind 220 kV Transmission Line are attached to the first structure located directly outside the Whirlwind Substation property line. This will be the side of the structure facing the substation. The Interconnection Customer shall own and maintain said structure, including the jumper loop. The Participating TO shall own and maintain the insulators that are used to attach the Participating TO-

owned conductors to the Interconnection Customer-owned structure, and all structures and conductors from that point into the Whirlwind Substation.

(b) Telecommunication OPGW: The Point of Change of Ownership shall be the point where the OPGW of the AV Solar One-Whirlwind 220kV Transmission Line is attached to the last structure located directly outside the Whirlwind property line.

6. **Point of Interconnection**: The Participating TO's Whirlwind Substation at the 220kV bus.

7. **One-Line Diagram of Interconnection to Whirlwind 220 kV Substation:**

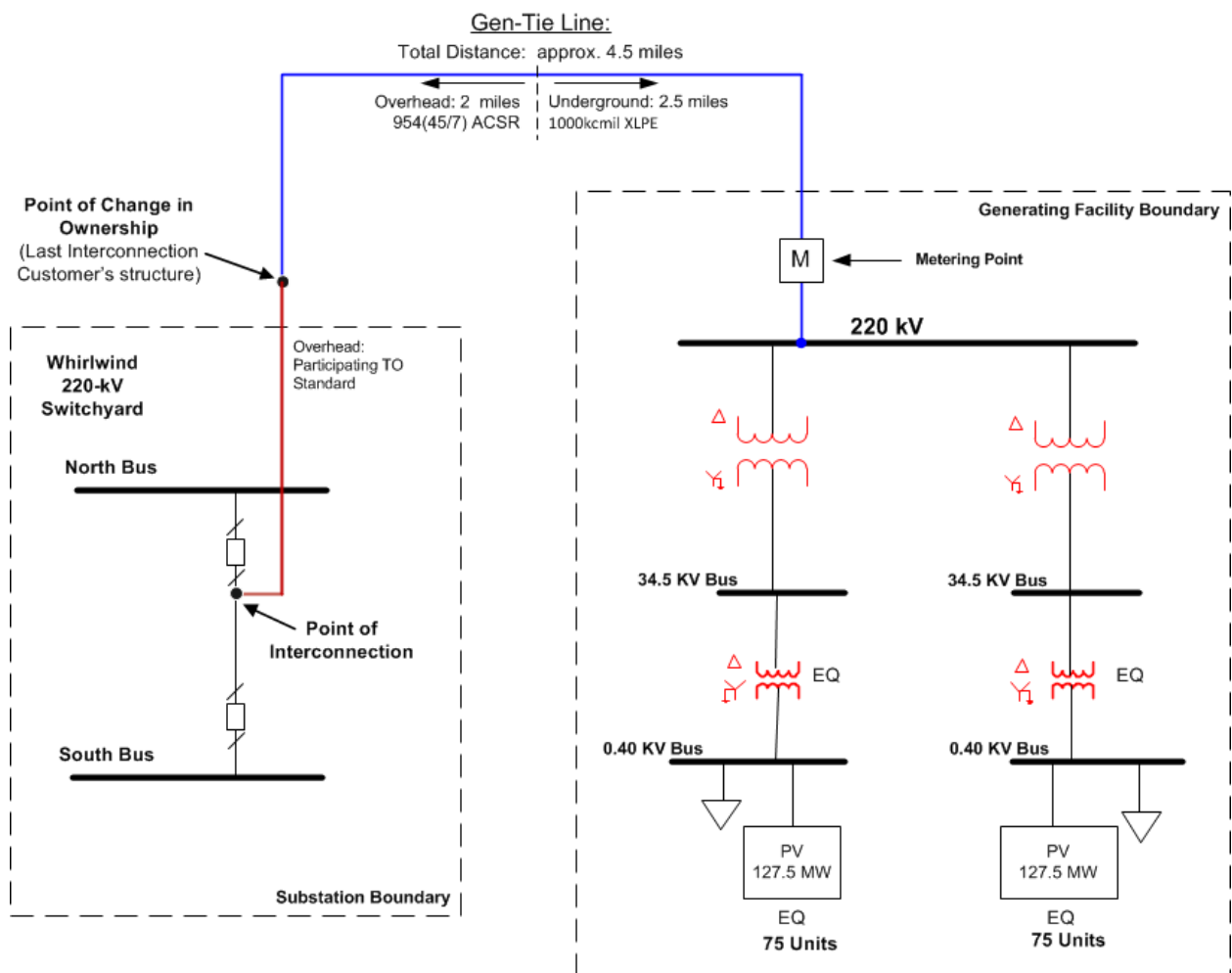

Note: This one-line diagram depicts technical information known by the Parties as of the date of the execution of this LGIA.

8. **Additional Definitions**: For the purposes of these Appendices, the following terms, when used with initial capitalization, whether in the singular or the plural, shall have the meanings specified below:

- (a) Abandoned Plant Approval: A FERC final order, not subject to rehearing or appeal, unconditionally granting the Participating TO's request for a declaratory order that the Participating TO can recover 100% of its prudently incurred costs for the Network Upgrades if such facilities are abandoned due to circumstances outside of the Participating TO's control.
- (b) Accounting Practice: Generally accepted accounting principles and practices applicable to electric utility operations.
- (c) American Recovery and Reinvestment Act ("ARRA"): An act of the United States Government published in 2009 (Pub. L. 111-5) (as the same may be amended or interpreted from time to time).
- (d) Capital Additions: Any modifications to the Participating TO's Interconnection Facilities in accordance with Article 5.19 of the LGIA. Such modifications may be any Units of Property which are added to the Participating TO's Interconnection Facilities; the enlargement, modification or betterment of any Units of Property constituting a part of the Participating TO's Interconnection Facilities ; or the replacement of any Units of Property constituting a part of the Participating TO's Interconnection Facilities, irrespective of whether such replacement constitutes an enlargement, modification or betterment of that which it replaces; the costs of which additions, enlargements, modifications, betterments or replacements in accordance with Accounting Practice would be capitalized and have not previously been included in the Interconnection Facilities Cost. If Capital Additions are required in order to benefit the Participating TO, or because of damage caused by negligence or willful misconduct of the Participating TO, then the Interconnection Customer will not bear cost responsibility for such Capital Additions, and no adjustment will be made to the Interconnection Facilities Cost, and no Capital Additions Cost or One-Time Cost will be charged to the Interconnection Customer for such Capital Additions.
- (e) Construction Activities: Actions by a Participating TO that result in irrevocable financial commitments for the purchase of major electrical equipment or land for Participating TO's Interconnection Facilities or Network Upgrades assigned to the Interconnection Customer that occur after receipt of all appropriate governmental approvals needed for the Participating TO's Interconnection Facilities or Network Upgrades
- (f) CPUC: The California Public Utilities Commission, or its regulatory successor.
- (g) Credit Support: A parent guarantee, letter of credit, surety bond, or other security meeting the requirements of Article 11.5 of the LGIA.
- (h) Customer-Financed Monthly Rate: The rate most recently adopted by the CPUC for application to the Participating TO's retail electric customers for added facilities, which does not compensate the Participating TO for replacement of

added facilities. The currently effective Customer-Financed Monthly Rate is as provided in Section 16 of this Appendix A.

- (i) Davis-Bacon Act: An act of the United States Government identified as 40 United States Code 267a *et seq.*, and related acts and regulations (as the same may be amended or interpreted from time to time).
- (j) Delivery Network Upgrades Cost: All costs, excluding One-Time Cost, determined by the Participating TO associated with the design, engineering, procurement, construction and installation of the Participating TO's Delivery Network Upgrades. The Delivery Network Upgrades Cost is provided in Section 15 of this Appendix A.
- (k) Delivery Network Upgrades Payment: The sum of the Delivery Network Upgrades Cost and associated One-Time Cost. The Delivery Network Upgrades Payment is provided in Section 17 of this Appendix A.
- (l) Distribution Upgrades Cost: All costs, excluding ITCC and One-Time Cost, determined by the Participating TO associated with the design, engineering, procurement, construction and installation of the Distribution Upgrades. The Distribution Upgrades Cost is provided in Section 15 of this Appendix A.
- (m) Distribution Upgrades Payment: The sum of the Distribution Upgrades Cost and the associated One-Time Cost. The Distribution Upgrades Payment is provided in Section 17 of this Appendix A.
- (n) Interconnection Facilities Charge: The monthly charge to the Interconnection Customer to recover the revenue requirements for the Participating TO's Interconnection Facilities, calculated as the product of the Customer-Financed Monthly Rate and the Interconnection Facilities Cost. The Interconnection Facilities Charge is provided in Section 16 of this Appendix A.
- (o) Interconnection Facilities Completion Date: The date upon which the construction of the Participating TO's Interconnection Facilities is complete and such facilities are successfully tested and ready for service.
- (p) Interconnection Facilities Cost: All costs, excluding One-Time Cost, determined by the Participating TO associated with the design, engineering, procurement, construction and installation of the Participating TO's Interconnection Facilities. The Interconnection Facilities Cost is provided in Section 15 of this Appendix A.
- (q) Interconnection Facilities Payment: The sum of the Interconnection Facilities Cost and associated One-Time Cost. The Interconnection Facilities Payment is provided in Section 17 of this Appendix A.

- (r) ITCC: The ITCC is equal to the estimated tax liability described in Article 5.17.4 of the LGIA, and is the Income Tax Component of Contribution specified in the Preliminary Statement, Part M of the Participating TO's tariff on file with the CPUC, applicable to the Distribution Upgrades Cost and Interconnection Facilities Cost. The ITCC applicable to the Distribution Upgrades Cost and Interconnection Facilities Cost is described in Section 11 of this Appendix A and is shown in Section 15 of this Appendix A.
- (s) Labor Laws: Laws required by the United States Government regarding labor issues, as stated in the Davis-Bacon Act, the Office of Federal Contract Compliance Programs Requirements and any other acts and regulations related thereto (as the same may be amended or interpreted from time to time).
- (t) Letter Agreement: The agreement between Interconnection Customer and Participating TO executed on November 22, 2010, Service Agreement No. 92, to advance work on Participating TO's Interconnection Facilities and certain Network Upgrades.
- (u) One-Time Cost: All costs determined by the Participating TO associated with the installation of the Participating TO's Delivery Network Upgrades, Distribution Upgrades, Participating TO's Interconnection Facilities, Participating TO's Reliability Network Upgrades, or Capital Additions which are not capitalized.
- (v) Reliability Network Upgrades Cost: All costs, excluding One-Time Cost, determined by the Participating TO associated with the design, engineering, procurement, construction and installation of the Participating TO's Reliability Network Upgrades. The Reliability Network Upgrades Cost is provided in Section 15 of this Appendix A.
- (w) Reliability Network Upgrades Payment: The sum of the Reliability Network Upgrades Cost and associated One-Time Cost. The Reliability Network Upgrades Payment is provided in Section 17 of this Appendix A.
- (x) Removal Cost: The actual cost the Participating TO incurs for the removal of the Participating TO's Interconnection Facilities, or any portion thereof which is calculated as the amount, if positive, of the costs of removal minus the salvage value of the Participating TO's Interconnection Facilities.
- (y) Special Protection System ("SPS"): A system that reduces or trips generation under contingency outages to maintain system stability or to limit overloads on system facilities.
- (z) Units of Property: As described in FERC's "List of Units of Property for Use in Connection with Uniform System of Accounts Prescribed for Public Utilities and Licensees" in effect as of the date of this LGIA, and as such list may be amended from time to time.

9. **Transmission Credits:** Subject to Section 13(d) of this Appendix A, no Congestion Revenue Rights or repayment will be made pursuant to Articles 11.4 and 11.4.1 of the LGIA because this LGIA assumes that the Participating TO will up-front finance the Network Upgrades described in Section 2 of this Appendix A.

10. **Security Amount for the Distribution Upgrades, Participating TO's Interconnection Facilities and Network Upgrades:**

- (a) Distribution Upgrades: Pursuant to Article 11.5 and Appendix B of the LGIA, the Interconnection Customer shall provide Credit Support in the amount of \$0 (zero dollars) to cover the costs for constructing, procuring and installing the Participating TO's Distribution Upgrades. The disposition of any released Credit Support shall be directed by the Interconnection Customer.
- (b) Participating TO's Interconnection Facilities: Interconnection Customer has made an initial posting of Interconnection Financial Security of \$592,600.00. Pursuant to Section 9 of the LGIP, and Article 11.5 and Appendix B of the LGIA, the Interconnection Customer shall provide additional Credit Support to bring the total amount of Interconnection Financial Security at the time of the second posting to \$1,791,900.00 and shall provide additional Credit Support at the time of the third posting to bring the total amount of Interconnection Financial Security to \$5,973,000.00 to cover the costs for constructing, procuring and installing the Participating TO's Interconnection Facilities.

Participating TO shall notify the Interconnection Customer of the date and amount of the third posting of Interconnection Financial Security no less than thirty (30) Calendar Days before the commencement of Construction Activities on Participating TO's Interconnection Facilities. The amount of the required Interconnection Financial Security shall be reduced dollar-for-dollar for payments the Interconnection Customer has made for work on the Participating TO's Interconnection Facilities under the Letter Agreement and this LGIA. Interconnection Financial Security shall not include any Credit Support posted for estimated tax liability.

The disposition of any released Credit Support shall be directed by the Interconnection Customer.

- (c) Network Upgrades: Interconnection Customer made an initial posting of Interconnection Financial Security in the amount of \$5,000,000.00. Until such time as the Participating TO receives Abandoned Plant Approval, Interconnection Customer agrees to maintain its initial posting of the Interconnection Financial Security.

Pursuant to FERC Order dated August 13, 2010 in Docket: ER10-1656-000, the requirement for the Interconnection Customer to make a second and third

posting of Interconnection Financial Security, as required under Section 9.3 of the CAISO Tariff, has been waived for Network Upgrades that the Participating TO has agreed to finance (which are identified in Section 2 of this Appendix A). This waiver is applicable only for such period of time as the Participating TO remains responsible for funding the Network Upgrades under this LGIA.

Pending Abandoned Plant Approval, and while the Participating TO maintains its commitment to finance the Network Upgrades, the Interconnection Customer shall not be required to post the second or third postings of Interconnection Financial Security. Credit Support related to the Network Upgrades shall be released within thirty (30) Calendar Days of the Participating TO's receipt of Abandoned Plant Approval.

Upon written notice by the Participating TO to the Interconnection Customer that the Participating TO is discontinuing its commitment to finance the Network Upgrades in accordance with Appendix A, Section 13(d), and intends to amend the LGIA to provide for the Interconnection Customer to finance the Network Upgrades, the Interconnection Customer shall provide additional Interconnection Financial Security pursuant to Section 9 of the LGIP and Article 11.5 and Appendix B of the LGIA to cover the costs for constructing, procuring and installing the Network Upgrades. Interconnection Customer shall be required to comply, within no less than sixty (60) Calendar Days, with Section 9.3 of the LGIP requiring posting of Interconnection Financial Security and to provide notice to the Parties of such compliance. If required under this Section 10, the total Interconnection Financial Security at the time of the second posting is \$7,837,500.00 and the total Interconnection Financial Security at the time of the third posting is \$26,125,000.00. The amount of the required Interconnection Financial Security shall be reduced dollar-for-dollar for payments the Interconnection Customer has made for work on the Network Upgrades under the Letter Agreement, except for monies already reimbursed or credited to the Interconnection Customer.

Prior to Abandoned Plant Approval or in the event that the Interconnection Customer is required to finance its share of the cost of the Network Upgrades, the Participating TO shall not perform any work on the Network Upgrades without Credit Support from the Interconnection Customer sufficient to cover the Interconnection Customer's share of the costs of such work. Participating TO shall have the right to draw upon the Credit Support provided as Interconnection Financial Security for the Interconnection Customer's share of the cost incurred by the Participating TO for the Network Upgrades.

The disposition of any released Credit Support shall be directed by the Interconnection Customer.

11. Security Amount for Estimated Tax Liability: Pursuant to Article 5.17.4 of the LGIA, the Interconnection Customer's estimated tax liability is as follows:

$(\text{Current Tax Rate} \times (\text{Gross Income Amount} - \text{Present Value of Tax Depreciation})) / (1 - \text{Current Tax Rate}) = 35\%$

Estimated tax liability for Distribution Upgrades = 35% * Distribution Upgrades Cost = 35% * (\$0) = \$0

Estimated tax liability for Participating TO's Interconnection Facilities = 35% * Interconnection Facilities Cost = 35% * (\$5,973,000) = \$2,090,550

Participating TO's Interconnection Facilities Cost = \$5,973,000

Distribution Upgrades Cost = \$0

The Interconnection Customer shall provide the Participating TO a letter of credit (or any other collateral instrument) in a form reasonably acceptable to the Participating TO pursuant to Article 5.17.3 and Appendix B of the LGIA. The letter of credit (or other collateral security) shall be increased by the amount and by the date indicated in the Payment Schedule (Appendix A, Section 17) under the column heading "ITCC Posting Requirement".

12. Removal of the Participating TO's Interconnection Facilities: Following termination of the LGIA, the Participating TO will remove the Participating TO's Interconnection Facilities from service to the Interconnection Customer pursuant to Article 2.5 of the LGIA. On or before the date one year following termination of the LGIA, the Participating TO shall notify the Interconnection Customer whether the Participating TO intends to physically remove the Participating TO's Interconnection Facilities, or any part thereof. If the Participating TO intends to physically remove the Participating TO's Interconnection Facilities, or any part thereof, then the Participating TO shall physically remove such facilities within two years from the date of notification of intent, and the Interconnection Customer shall pay the Removal Cost. If the Participating TO does not intend to physically remove the Participating TO's Interconnection Facilities, or any part thereof, then the Interconnection Customer shall have no obligation to pay such Removal Cost.

13. Charges:

(a) The Interconnection Customer shall pay to the Participating TO the following charges in accordance with the LGIA: (i) Distribution Upgrades Payment; (ii) Delivery Network Upgrades Payment; (iii) Interconnection Facilities Payment; (iv) Reliability Network Upgrades Payment; (v) payments for any Capital Additions; (vi) Interconnection Facilities Charge; (vii) any reimbursable FERC fees pursuant to Section 14(g) of this Appendix A; (viii) Removal Cost pursuant to Article 2.4.3 of the LGIA and Section 12 of this Appendix A; (ix) termination charges pursuant to Article 2.4 of the LGIA; however, to the extent that the costs of the Participating TO's Network Upgrades have received Abandoned Plant Approval,

the Interconnection Customer shall not be responsible for its share of those charges; (x) disconnection costs pursuant to Article 2.5 of the LGIA; and (xi) suspension costs pursuant to Article 5.16 of the LGIA.

- (b) The Distribution Upgrades Cost, Delivery Network Upgrades Cost, Interconnection Facilities Cost, Reliability Network Upgrades Cost, associated One-Time Cost and Removal Cost shall be compiled in accordance with Accounting Practice.
- (c) If, during the term of the LGIA, the Participating TO executes an agreement to provide service to another entity (other than for retail load) which contributes to a need for the Participating TO's Interconnection Facilities, the charges due hereunder may be adjusted to appropriately reflect such service based on the Participating TO's cost allocation principles in effect at such time subject to FERC's approval.
- (d) The Participating TO commits to up-front finance the Network Upgrades and the associated One-Time Cost specifically identified in Section 2 of this Appendix A to the LGIA, contingent upon satisfactory receipt, as determined solely by the Participating TO, of the following:
 - (i) Abandoned Plant Approval, and
 - (ii) Continued achievement of development milestones by the Interconnection Customer, as described in Table 1 below.

If the Participating TO has not received Abandoned Plant Approval within six (6) months of applying for such approval, the Participating TO shall have the right to amend this LGIA such that the Interconnection Customer shall be responsible for financing its share of the costs of the Network Upgrades, subject to FERC's acceptance or approval. The Interconnection Customer shall make its election pursuant to Article 11.4 at that time.

Table 1: Participating TO and Interconnection Customer Milestones and Decision Points

Group 1 Milestones and Decision Point #1	
Participating TO Milestone	Interconnection Customer Milestone
<ul style="list-style-type: none"> • Participating TO receives Abandoned Plant Approval • Participating TO completes final design and engineering for the Participating TO's Interconnection Facilities, Distribution Upgrades, and Participating TO's Reliability Network Upgrades. 	<ul style="list-style-type: none"> • Interconnection Customer selects Engineering, Procurement and Construction ("EPC") contractor • Interconnection Customer demonstrates commencement of construction of the Generating Facility and the Interconnection Customer's Interconnection Facilities. Commencement of construction can be demonstrated by providing evidence of notable site preparation and substantial procurement of materials.
<p align="center">DECISION POINT #1: Following Participating TO's written notification of Participating TO's completion of all of its Group 1 milestones, the Interconnection Customer must demonstrate that it has completed all of its Group 1 milestones within ninety (90) Calendar Days of the Participating TO's notification or by September 30, 2011, whichever is later. Parties exercise options as outlined in Table 2.</p>	

Group 2 Milestones and Decision Point #2	
Participating TO Milestone	Interconnection Customer Milestone
<ul style="list-style-type: none"> • Participating TO commences construction of the Participating TO's Reliability Network Upgrades 	<ul style="list-style-type: none"> • Interconnection Customer secures 100% of financing to construct the Generating Facility and the Interconnection Customer's Interconnection Facilities
<p align="center">DECISION POINT #2: Following Participating TO's written notification of Participating TO's completion of all of its Group 2 milestones, the Interconnection Customer must demonstrate that it has completed all of its Group 2 milestones within thirty (30) Calendar Days of the Participating TO's notification or by December 31, 2011, whichever is later. Parties exercise options as outlined in Table 2.</p>	

Group 3 Milestones and Decision Point #3

Participating TO Milestone	Interconnection Customer Milestone
<ul style="list-style-type: none"> • Participating TO energizes the Participating TO’s Reliability Network Upgrades necessary for Interconnection Customer to interconnect to the Whirlwind Substation (as described in item g.1 of Section 2 of Appendix B) to enable Commercial Operation of the Generating Facility 	<ul style="list-style-type: none"> A. Provide “implementation plan” for Commercial Operation agreeable to Participating TO and the CAISO B. Initial parallel operation of the first block of solar panels of no less than 30 MW of installed capacity C. Commercial Operation of entire Generating Facility

DECISION POINT #3: Following Participating TO’s written notification of Participating TO’s completion of its Group 3 milestone, the Interconnection Customer must demonstrate that it has completed all of its Group 3 milestones as follows:

- Milestone A: Within thirty (30) Calendar Days of the Participating TO’s notification;
- Milestone B: Within ninety (90) Calendar Days of the Participating TO’s notification;
- Milestone C: Within twenty-four (24) months of the Participating TO’s notification.

Parties exercise options as outlined in Table 2.

Table 2: Actions by the Parties at each Decision Point:

Table 2A- Participating TO:

At each Decision Point as outlined in Table 1 above, if the Interconnection Customer is current in meeting its milestones in Table 1 above (as such milestones may be adjusted due to the Interconnection Customer exercising option 2 in Table 2B below), the Participating TO shall confirm its commitment to finance Network Upgrades.

If the Interconnection Customer is not current in meeting its milestones as outlined in Table 1 (as such milestones may be adjusted due to the Interconnection Customer exercising option 2 in Table 2B below), the Participating TO has the following additional options:

- 1) Confirm its commitment to finance the Network Upgrades (but have no obligation to do so).
- 2) Discontinue its commitment to finance Interconnection Customer's share of the cost of the Network Upgrades, in which case its share of Network Upgrades cost may then be financed by the Interconnection Customer pursuant to Section 13(h) of Appendix A.
- 3) Extend the applicable deadline for Interconnection Customer to satisfy the milestone requirement.
- 4) Terminate the LGIA, subject to the termination provisions in the LGIA including Article 2.3, and Sections 13(g) and 13(h) of this Appendix A.
- 5) Other actions mutually agreeable to both parties.

If the Participating TO does not exercise any of the options in writing, then it shall be deemed to have elected option 1. If the Participating TO chooses any option other than option 1, the Participating TO shall provide written notice to the Interconnection Customer at least five (5) Business Days before exercising the option.

Table 2B – Interconnection Customer:

At each Decision Point as outlined in Table 1 above, if the Participating TO is current in meeting its milestones in Table 1 above, the Interconnection Customer shall confirm its commitment to develop its Generating Facility.

If the Participating TO is not current in meeting its milestones as outlined in Table 1, the Interconnection Customer has the following additional options:

- 1) Continue to develop its Generating Facility (but have no obligation to do so).
- 2) Adjust its development milestones in Table 1 above, on a day-for-day basis, as appropriate, to the Participating TO's new timetable(s).
- 3) Terminate the LGIA, subject to the termination provisions in the LGIA.
- 4) Other actions mutually agreeable to both parties.

If the Interconnection Customer does not exercise any of the options in writing, then it shall be deemed to have elected option 1. If the Interconnection Customer chooses any option other than option 1, the Interconnection Customer shall provide written notice to the Participating TO at least five (5) Business Days before exercising the option.

- (e) The determination of whether the Interconnection Customer has met its milestones outlined in Table 1 under Section 13(d) above shall be at the sole discretion of the Participating TO. The determination of whether the Participating TO has met its milestones outlined in Table 1 under Section 13(d) above shall be at the sole discretion of the Interconnection Customer. If there is a dispute as to whether the Interconnection Customer or Participating TO has met a milestone required in Table 1 under Section 13(d) above, such dispute shall be resolved pursuant to Article 27 of the LGIA.
- (f) Except for network upgrades that the Participating TO may be required to finance pursuant to the LGIP, the Participating TO is under no obligation to finance other network upgrades if the Network Upgrades identified in Appendix A are modified and such modification results in the Participating TO having to reaffirm Abandoned Plant Approval for the modified Network Upgrades. If the Network Upgrades identified in Appendix A are modified, the Interconnection Customer shall adjust its posting of Interconnection Financial Security to bring it into accordance with the requirements of the Section 9 of the LGIP.
- (g) If the Interconnection Customer does not meet any one of the milestones specified in Table 1 under Section 13(d) above (as such milestones may be adjusted due to the Interconnection Customer exercising option 2 in Table 2B above), this failure shall be considered a Breach of this LGIA, subject to the Default and Right to Terminate provisions under Article 17 of this LGIA. Each

milestone in Table 1 of Section 13(d) shall be subject to the Force Majeure provisions of this LGIA.

- (h) Notwithstanding anything to the contrary in Table 2A under Section 13(d), Interconnection Customer shall not be in Breach of this LGIA, and the Participating TO shall not have the right to terminate this LGIA, as a result of the Interconnection Customer missing a milestone in Table 1 under Section 13(d), provided that the Parties: (i) reasonably and in good faith negotiate an amendment of this LGIA to provide for Interconnection Customer financing of its share of the costs of the Network Upgrades; and (ii) reach agreement on such amendment within sixty (60) Calendar Days after Participating TO's notification of its having exercised option 2 or 4 under Table 2A of Appendix A. Such amendment shall credit Interconnection Customer for any payments provided for Network Upgrades, Interconnection Facilities and ITCC requirements already made by, and not already reimbursed or credited to, the Interconnection Customer under this LGIA or under the Letter Agreement.
- (i) The Participating TO and the Interconnection Customer shall provide the other Parties a monthly status report, including all supporting documentation, regarding (i) in the case of the Participating TO, progress towards obtaining the Abandoned Plant Approval and the Participating TO progress in carrying out the design, procurement and construction of the Participating TO's Interconnection Facilities and the Network Upgrades and (ii) in the case of the Interconnection Customer, progress towards satisfying the milestones in Table 1 of this Appendix A and the Interconnection Customer's progress in carrying out the design, procurement and construction of the Interconnection Customer's Interconnection Facilities and Generating Facility. The Participating TO and the Interconnection Customer agree to provide the other Parties its concurrence or exception to the Party that is claiming to have reached one of its milestones, in accordance with Table 2(A) and Table 2(B).
- (j) The Participating TO shall endeavor to file with FERC for Abandoned Plant Approval within sixty (60) Calendar Days of filing of this LGIA.
- (k) Each Party shall make Reasonable Efforts to support the other Party's key regulatory processes and filings to achieve the In-Service Date specified in Appendix B.
- (l) The Participating TO shall refund the amount received from the Interconnection Customer for Network Upgrades under the Letter Agreement or the LGIA within thirty (30) Calendar Days of the Participating TO's receipt of Abandoned Plant Approval; provided, however, that if Abandoned Plant Approval is not received before the Commercial Operation Date, the Parties agree to amend this LGIA so that (1) the Participating TO reimburses the Interconnection Customer for amounts paid to the Participating TO for costs of Network Upgrades in accordance with Article 11.4.1 of the LGIA and Section 12.3.2 of the LGIP, and

(2) if Abandoned Plant Approval occurs after the Commercial Operation Date, the Participating TO shall refund the remaining balance within thirty (30) Calendar Days. Such refund shall include interest calculated in accordance with the methodology set forth in FERC's regulations at 18 C.F.R. § 35.19(a)(2)(iii) from the date of receipt of payment to the date on which the Interconnection Customer receives such refund.

(m) After Abandoned Plant Approval is obtained, and while Participating TO continues its commitment to finance the Network Upgrades, at no time will the Participating TO require payment from the Interconnection Customer for any Network Upgrades for which Abandoned Plant Approval has been obtained, provided that the costs of such Network Upgrades are incurred while the Interconnection Customer is current with meeting its development milestones pursuant to Section 13(d).

(n) If by March 31, 2011, FERC has not unconditionally accepted this LGIA, the Interconnection Customer may request that the Participating TO tender a revised version of the LGIA that provides for the Interconnection Customer to finance its share of the cost of Network Upgrades. The Interconnection Customer shall make such a request only if it determines in good faith that it will be necessary for the Interconnection Customer to amend the LGIA to receive financing for the Generating Facility on terms acceptable to the Interconnection Customer. In the event the Interconnection Customer requests tender of a revised version of the LGIA pursuant to this paragraph, the Participating TO shall tender to the Parties the revised version of the LGIA within ten (10) Calendar Days of receipt of the request, or within such other period of time as the Parties may agree. The Parties shall negotiate in good faith with the objective of executing and filing at FERC the amended LGIA no later than thirty (30) Calendar Days after the Interconnection Customer requests a revised version of the LGIA.

14. Supplemental Billing and Payment Provisions:

(a) Pursuant to Article 12.1 of the LGIA, the Participating TO shall submit to the Interconnection Customer invoices due for the preceding month for the Distribution Upgrades Payment, Delivery Network Upgrades Payment, Interconnection Facilities Payment, and Reliability Network Upgrades Payment.

(b) Pursuant to Article 10.5 of the LGIA, commencing on or following the Interconnection Facilities Completion Date, each month the Participating TO will render bills to the Interconnection Customer for the Interconnection Facilities Charge. The Interconnection Facilities Charge payments shall initially be based on the estimated Interconnection Facilities Cost as specified in Section 15 of this Appendix A, and shall be subject to later adjustment pursuant to Section 14(b)(i) and 14(b)(ii). The Interconnection Facilities Charge for the first and last month of service hereunder shall be pro-rated based on the number of days in which service was provided during said months.

- (i) If the amounts paid for the Interconnection Facilities Charge are less than the amounts due for the Interconnection Facilities Charge as determined from the actual recorded Interconnection Facilities Cost, Participating TO will bill Interconnection Customer the difference between the amounts previously paid by the Interconnection Customer and the amounts which would have been paid based on actual recorded costs, without interest, on the next regular billing.
 - (ii) If the amounts paid for the Interconnection Facilities Charge are greater than the amounts due for the Interconnection Facilities Charge as determined from the actual recorded Interconnection Facilities Cost, Participating TO will credit Interconnection Customer the difference between the amounts previously paid by the Interconnection Customer and the amounts which would have been paid based on actual recorded costs, without interest, on the next regular billing.
- (c) In the event that any portion of Participating TO's Interconnection Facilities is not complete but, at the request of Interconnection Customer, Participating TO commences interconnection service under this LGIA notwithstanding the incomplete facilities, Participating TO shall commence billing, and Interconnection Customer shall pay, the Interconnection Facilities Charge commencing on the date that such service commences.
- (d) In accordance with Article 5.19.3 of the LGIA, the Participating TO shall submit to the Interconnection Customer invoices due for the preceding month for the payments due for Capital Additions, if any.
 - (i) For Capital Additions that are the cost responsibility of the Interconnection Customer, prior to commencing work, the Participating TO will provide at least sixty (60) Calendar Days advance written notification to the Interconnection Customer, except that, at the Participating TO's sole discretion, the Participating TO may commence the work on the Capital Additions with either shorter advance written notification or written notification after the work has commenced if the Participating TO determines that the Capital Additions are required in accordance with safety or regulatory requirements or to preserve system integrity or reliability. The written notification will include the estimated cost of the Capital Additions, and the amount of and due date for the security, if any, required to be paid by the Interconnection Customer sufficient to cover the costs for constructing, procuring and installing the Capital Additions consistent with the applicable terms of Article 11.5 of the LGIA.
 - (ii) Except as provided in Section 8(d) above, if certain Participating TO's Interconnection Facilities are removed to accommodate Capital Additions and such removal results in a change in the Interconnection Facilities Cost, the Interconnection Facilities Charge shall be adjusted as of the in-service date of

such Capital Additions to reflect the change in the Interconnection Facilities Cost.

- (iii) Except as provided in Section 8(d) above, if Capital Additions result in an increase in the Interconnection Facilities Cost, then the Interconnection Facilities Charge shall be adjusted as of the in-service date of such Capital Additions to reflect the change in such costs.

- (e) As soon as reasonably practicable, but within twelve (12) months after the in-service date of any Capital Additions, the Participating TO shall provide an invoice of the final cost of the construction of the Capital Additions to the Interconnection Customer, and shall set forth such costs in sufficient detail to enable the Interconnection Customer to compare the actual costs with the estimates and to ascertain deviations, if any, from the cost estimates. The Participating TO shall refund to the Interconnection Customer any amount by which the payment made by the Interconnection Customer for estimated costs of the Capital Additions exceeds the actual costs of construction within thirty (30) Calendar Days of the issuance of such final construction invoice; or, in the event the actual costs of construction exceed the Interconnection Customer's payment made for the estimated costs of the Capital Additions, then the Interconnection Customer shall pay to the Participating TO any amount by which the actual costs of construction exceed the payment made by the Interconnection Customer for estimated costs within thirty (30) Calendar Days of the issuance of such final construction invoice.

- (f) If, in accordance with the removal of the Participating TO's Interconnection Facilities specified in Section 12 above, the Participating TO decides to physically remove the Participating TO's Interconnection Facilities, or any part thereof, the Participating TO shall render a bill to the Interconnection Customer for the Removal Cost. The Interconnection Customer shall pay the Removal Cost in accordance with Article 2.4.3 of the LGIA. Such billing shall initially be based on the Participating TO's estimate of the Removal Cost. Within twelve (12) months following the removal of the Participating TO's Interconnection Facilities, or any part thereof, the Participating TO shall determine the actual Removal Cost and provide the Interconnection Customer with a final invoice. The Participating TO shall refund to the Interconnection Customer any amount by which the payment by the Interconnection Customer for the estimated Removal Cost exceeds the actual Removal Cost within thirty (30) Calendar Days of the issuance of such final invoice; or, in the event the actual Removal Cost exceeds the Interconnection Customer's payment for the estimated Removal Cost, then the Interconnection Customer shall pay to the Participating TO any amount by which the actual Removal Cost exceeds the payment by the Interconnection Customer for the estimated Removal Cost within thirty (30) Calendar Days of the issuance of such final invoice.

(g) The Interconnection Customer shall reimburse the Participating TO for all fees and charges related to the FERC fees and annual charges provided in Sections 381 and 382 of the FERC's regulations (18 C.F.R. § 381 and 382), as such regulation may from time to time be amended, that are imposed on the Participating TO attributable to the service provided under the LGIA, or any amendments thereto. The Participating TO will render bills to the Interconnection Customer for any such fees and charges incurred since the preceding billing. As of the Effective Date, no such fees and charges have been imposed on the Participating TO attributable to the service provided under the LGIA.

15. Distribution Upgrades Cost, Reliability Network Upgrades Cost, Delivery Network Upgrades Cost and Interconnection Facilities Cost Summary:

(a) Estimated Cost⁽¹⁾:

Element-	Interconnection Facilities Cost	Distribution Upgrades Cost	Reliability Network Upgrades Cost ⁽²⁾	Delivery Network Upgrades Cost ⁽²⁾	One-Time Cost	Total Cost	ITCC
Participating TO's Interconnection Facilities	\$5,973,000					\$5,973,000	\$2,090,550
Distribution Upgrades		\$0				\$0	\$0
Reliability Network Upgrades (plan of service)			\$2,745,000			\$2,745,000	\$0
Reliability Network Upgrades			\$2,487,000			\$2,487,000	\$0
Delivery Network Upgrades				\$20,893,000		\$20,893,000	\$0
Total	\$5,973,000	\$0	\$5,232,000	\$20,893,000	\$0	\$32,098,000	\$2,090,550

- Notes: 1. All amounts shown are in nominal dollars.
 2. Network Upgrades costs are shown for information purposes only since the Participating TO has agreed to finance the Network Upgrades, subject to Section 13 of this Appendix A.

(b) Actual Cost:

[TO BE INSERTED AFTER TRUE-UP OF ACTUAL COSTS]

Element-	Interconnection Facilities Cost	Distribution Upgrades Cost	Reliability Network Upgrades Cost*	Delivery Network Upgrades Cost*	One-Time Cost	Total Cost	ITCC
Participating TO's Interconnection Facilities							
Distribution Upgrades							
Reliability Network Upgrades (plan of service)							
Reliability Network Upgrades							
Delivery Network Upgrades							
Total							

16. Interconnection Facilities Charge:

Interconnection Facilities Charge = Customer-Financed Monthly Rate x (Interconnection Facilities Cost)

Effective	Customer-Financed Monthly Rate	Estimated		Actual	
		Interconnection Facilities Cost	Interconnection Facilities Charge	Interconnection Facilities Cost	Interconnection Facilities Charge
As of the Interconnection Facilities Completion Date	0.38%	\$5,973,000.00	\$22,697.40	[to be inserted after true-up]	[to be inserted after true-up]

17. Payment Schedule:

The payment amounts shown below are based on an estimate of the monthly incurred costs for the Participating TO's Interconnection Facilities, and Distribution Upgrades.

Payment No.	Payment Due Date	Interconnection Facilities Cost (A)	Network Upgrades Cost (B)	Interconnection Facilities One-Time Cost (C)	Total Payment Amount (K = A + B + C)	ITCC (D) = (A * 35%)	ITCC Posting Requirement
1	12/1/2010	\$592,600 1st Installment in Letter Agreement *	\$0	\$0	\$592,600	\$207,410 1st Posting Requirement in Letter Agreement *	\$306,810
2	1/1/11	\$284,000	\$0	\$0	\$284,000	\$99,400	\$0
3	2/1/11	\$400,000 2nd Installment in Letter Agreement *	\$0	\$0	\$400,000	\$140,000 2nd Posting Requirement in Letter Agreement *	\$407,050
4	3/1/11	\$372,000	\$0	\$0	\$372,000	\$130,200	\$0
5	4/1/11	\$391,000	\$0	\$0	\$391,000	\$136,850	\$0
6	5/1/2011	\$380,000 3rd Installment in Letter Agreement *	\$0	\$0	\$380,000	\$133,000 3rd Posting Requirement in Letter Agreement *	\$372,750
7	6/1/11	\$354,000	\$0	\$0	\$354,000	\$123,900	\$0
8	7/1/11	\$331,000	\$0	\$0	\$331,000	\$115,850	\$0
9	8/1/11	\$305,000	\$0	\$0	\$305,000	\$106,750	\$363,440
10	9/1/11	\$377,400	\$0	\$0	\$377,400	\$132,090	\$0
11	10/1/11	\$356,000	\$0	\$0	\$356,000	\$124,600	\$0
12	11/1/11	\$293,000	\$0	\$0	\$293,000	\$102,550	\$365,050
13	12/1/11	\$361,000	\$0	\$0	\$361,000	\$126,350	\$0
14	1/1/12	\$389,000	\$0	\$0	\$389,000	\$136,150	\$0
15	2/1/12	\$372,000	\$0	\$0	\$372,000	\$130,200	\$237,650
16	3/1/12	\$237,000	\$0	\$0	\$237,000	\$82,950	\$0
17	4/1/12	\$70,000	\$0	\$0	\$70,000	\$24,500	\$0
18	5/1/12	\$46,000	\$0	\$0	\$46,000	\$16,100	\$37,800
19	6/1/12	\$32,000	\$0	\$0	\$32,000	\$11,200	\$0
20	7/1/12	\$30,000	\$0	\$0	\$30,000	\$10,500	\$0
Totals		\$5,973,000	\$0	\$0	\$5,973,000	\$2,090,550	\$2,090,550

*Payments under this schedule shall be made in accordance with Section 18 of this Appendix A.

All amounts shown above are in nominal dollars.

Interconnection Facilities Payment = (Interconnection Facilities Cost + associated One-Time Cost) = \$5,973,000.

Distribution Upgrades Payment = (Distribution Upgrades Cost + associated One-Time Cost) = \$0.

Reliability Network Upgrades Payment = (Reliability Network Upgrades Cost +

associated One-Time Cost) = \$ 0 since the Participating TO has agreed to finance the Participating TO's Network Upgrades, subject to Section 13 of this Appendix A.

Delivery Network Upgrades Payment = (Delivery Network Upgrades Cost + associated One-Time Cost) = \$ 0 since the Participating TO has agreed to finance the Participating TO's Network Upgrades, subject to Section 13 of this Appendix A.

Credit Support for ITCC shall be provided by the Interconnection Customer in accordance with Appendix A, Section 11.

18. Additional Payment Terms.

- (a) Interconnection Customer's payments and requirements to post security for payment of ITCC pursuant to this LGIA shall not begin until acceptance of this LGIA by FERC and termination of the Letter Agreement in accordance with its terms.
- (b) No later than fifteen (15) Calendar Days after acceptance of this LGIA by FERC (or, if a compliance filing is required by FERC, no later than fifteen (15) Calendar Days after acceptance of the compliance filing), and termination of the Letter Agreement in accordance with its terms, the Participating TO shall provide the Interconnection Customer with a report (the "Transition Report") in which the Participating TO shall indicate how it intends to apply credit for payments made, and Credit Support posted, by the Interconnection Customer under the Letter Agreement to its corresponding payment and Credit Support obligations pursuant to this LGIA.
- (c) No later than fifteen (15) Calendar Days after the Transition Report is received, the Interconnection Customer shall be required to make a one-time transition payment to reconcile the payments made under the Letter Agreement with the payments due under the payment schedule in Section 17 of the LGIA: If at the time that the Interconnection Customer's obligation to make payments under this LGIA begins, the Interconnection Customer has not made payments due under the payment schedule in Section 17 of this Appendix A, the transition payment shall be the sum of the payments then due under the payment schedule less the payments made under the Letter Agreement.
- (d) No later than fifteen (15) Calendar Days after the Transition Report is received, the Interconnection Customer shall increase the amount of security posted for ITCC to the sum of the amounts then due under the schedule in Section 17 of this Appendix A.
- (e) The Parties believe that as a result of work under the Letter Agreement or this LGIA, there may be changes to the Participating TO's Interconnection Facilities, particularly with regard to what telecommunications facilities will be required. Thus, the Parties agree that no later than thirty (30) Calendar Days before Construction Activities for the Participating TO's Interconnection Facilities

commence, the Participating TO shall notify the Interconnection Customer of any material change, if any, in the scope of work for the Participating TO's Interconnection Facilities and shall provide revised versions of the scope of work in Appendix A, Section 1(b), the table of cost estimates found in Appendix A, Section 15, the revised payment schedule found in Appendix A, Section 17, and an update of the amount of Interconnection Financial Security required. Upon agreement by the Parties on the updated schedules, the Participating TO, and the CAISO, if required, shall file an amendment to this LGIA reflecting such updated schedules at FERC.

**Appendix B
To LGIA**

Milestones

1. The Interconnection Customer's Selected Option: Pursuant to Article 5.1 of the LGIA, the Interconnection Customer has selected the Standard Option.

2. Milestone Dates:

<u>Item</u>	<u>Milestone</u>	<u>Responsible Party</u>	<u>Due Date (*)</u>
(a)	Submit proof of insurance coverage in accordance with Article 18.3 of the LGIA	Interconnection Customer	Within ten (10) Calendar Days of the execution of this LGIA
(b)	Submittal of written authorization to proceed with design and procurement of the Participating TO's Interconnection Facilities and Network Upgrades to the Participating TO and CAISO in accordance with Article 5.5.2 of the LGIA.	Interconnection Customer	To the extent not already provided in the Letter Agreement, within ten (10) Calendar Days of the Effective Date
(c)	Submittal of second posting of Interconnection Financial Security for the Participating TO's Interconnection Facilities and Network Upgrades to the Participating TO pursuant to Section 9 of the LGIP, and Article 11.5 and Sections 10 and 13(d) of Appendix A of the LGIA	Interconnection Customer	One hundred eighty (180) Calendar Days after issuance of the final Phase II Interconnection Study, which is January 5, 2011
(d)	Submittal of third posting of Interconnection Financial Security for the Participating TO's Interconnection Facilities and Network Upgrades to the Participating TO pursuant to Section 9 of the LGIP and Article 11.5 and Sections 10 and 13(d) of Appendix A of the LGIA	Interconnection Customer	June 1, 2011.
(e)	Submittal of written authorization to proceed with construction of the Participating TO's Interconnection Facilities and Network Upgrades to the Participating TO and the CAISO pursuant to Article 5.6.3 of the LGIA	Interconnection Customer	June 1, 2011

<u>Item</u>	<u>Milestone</u>	<u>Responsible Party</u>	<u>Due Date (*)</u>
(f)	Submittal of security for the estimated tax liability to the Participating TO pursuant to Article 5.17.3 of the LGIA	Interconnection Customer	Within thirty (30) Calendar Days of the acceptance of the LGIA and termination of the Letter Agreement
(g).1	Completion of the Participating TO's Interconnection Facilities and those Participating TO's Reliability Network Upgrades necessary for Interconnection Customer to interconnect to the Whirlwind Substation (**)	Participating TO	Within twenty-one (21) months following execution by all Parties of this LGIA (***)
(g).2	Completion of all Reliability Network Upgrades	Participating TO	Within twenty-four (24) months following execution by all Parties of this LGIA
(g).3	Completion of all the Participating TO's Interconnection Facilities	Participating TO	Within thirty (30) months following execution by all Parties of this LGIA
(g).4	Completion of the Delivery Network Upgrades	Participating TO	Within thirty-six (36) months following execution by all Parties of this LGIA
(h)	Submittal of initial specifications for the Interconnection Customer's Interconnection Facilities and AV Solar One Project, including System Protection Facilities, to the Participating TO and the CAISO pursuant to Article 5.10.1 of the LGIA	Interconnection Customer	At least one hundred eighty (180) Calendar Days prior to the Initial Synchronization Date
(i)	Initial information submission which shall include the Participating TO's Transmission System information necessary to allow the Interconnection Customer to select equipment, in accordance with Article 24.2 of the LGIA	Participating TO	At least one hundred eighty (180) Calendar Days prior to Trial Operation
(j)	Updated information submission by the Interconnection Customer, including manufacturer information in accordance with Article 24.3 of the LGIA	Interconnection Customer	No later than one hundred eighty (180) Calendar Days prior to Trial Operation

<u>Item</u>	<u>Milestone</u>	<u>Responsible Party</u>	<u>Due Date (*)</u>
(k)	Review of and comment on the Interconnection Customer's initial specifications pursuant to Article 5.10.1 of the LGIA	Participating TO and CAISO	Within thirty (30) Calendar Days of the Interconnection Customer's submission of initial specifications
(l)	Submittal of final specifications for the Interconnection Customer's Interconnection Facilities and AV Solar One Project, including System Protection Facilities, to the Participating TO and the CAISO as specified in Article 5.10.1 of the LGIA	Interconnection Customer	At least ninety (90) Calendar Days prior to the Initial Synchronization Date
(m)	Review of and comment on the Interconnection Customer's final specifications pursuant to Article 5.10.1 of the LGIA	Participating TO and CAISO	Within thirty (30) Calendar Days of the Interconnection Customer's submission of final specifications
(n)	Notification of Balancing Authority Area to the Participating TO and CAISO pursuant to Article 9.2	Interconnection Customer	At least three (3) months prior to the Initial Synchronization Date
(o)	Performance of a complete calibration test and functional trip test of the System Protection Facilities pursuant to Article 9.7.4.6 of the LGIA	Interconnection Customer and Participating TO	At least sixty (60) Calendar Days prior to the In-Service Date
(p)	In-service date of the Interconnection Customer's Interconnection Facilities	Interconnection Customer	Within twenty-one (21) months following execution by all Parties of this LGIA
(q)	Initial Synchronization Date/Trial Operation begins	Interconnection Customer	Within twenty-one (21) months following execution by all Parties of this LGIA
(r)	Performance of a complete calibration test and functional trip test of the System Protection Facilities pursuant to Article 9.7.4.6 of the LGIA	Interconnection Customer and Participating TO	At least sixty (60) Calendar Days prior to the Commercial Operation Date
(s)	Testing in accordance with Article 6.1 of the LGIA of the Participating TO's Interconnection Facilities, Distribution Upgrades and Network Upgrades described in (g.1) and testing of the Interconnection Customer's Interconnection Facilities and AV Solar One Project then in existence.	Interconnection Customer and Participating TO	At least sixty (60) Calendar Days prior to the Initial Synchronization Date

<u>Item</u>	<u>Milestone</u>	<u>Responsible Party</u>	<u>Due Date (*)</u>
(t)	Provide written approval to the Interconnection Customer for the operation of the AV Solar One Project in accordance with Article 6.1 of the LGIA	Participating TO	At least fifteen (15) Calendar Days prior to the Initial Synchronization Date
(u)	Commercial Operation Date for the entire Generating Facility	Interconnection Customer	December 31, 2013
(v)	Submittal of "as-built" drawings, information and documents for the Interconnection Customer's Interconnection Facilities and the Electric Generating Units in accordance with Article 5.10.3 of the LGIA to the Participating TO and the CAISO	Interconnection Customer	Within one hundred twenty (120) Calendar Days after the Commercial Operation Date for the entire Generating Facility, unless otherwise agreed
(w)	Release of Interconnection Financial Security for Participating TO Interconnection Facilities	Participating TO	As soon as reasonably practicable, but within one (1) month of completion of construction
(x)	Release of Interconnection Financial Security for Network Upgrades	Participating TO	As soon as reasonably practicable, but no later than one (1) month after the Commercial Operation Date for the entire Generating Facility

- Notes:
- * The Interconnection Customer understands and acknowledges that such timeline is only an estimate and that equipment and material lead times, labor availability, outage coordination, regulatory approvals, right-of-way negotiations, or other unforeseen events could delay the actual in-service dates of the Participating TO's Interconnection Facilities, Distribution Upgrades, or Network Upgrades beyond those specified. The Participating TO shall not be liable for any cost or damage incurred by the Interconnection Customer because of any delay in the work provided for in this LGIA.
 - ** The Participating TO's Interconnection Facilities and Participating TO's Reliability Network Upgrades necessary for the AV Solar Ranch One Project to begin Commercial Operation are all of the facilities listed in Appendix A, Section 1 and 2, except 1(b)(v) (second communication line), 2(b)(i)2a (SPS), 2(b)(i)2c (short-circuit duty mitigation), and 2(b)(ii)a (Delivery Network Upgrades).
 - *** The Interconnection Customer has requested a March 1, 2012 in-service date for the Participating TO's Interconnection Facilities and Participating TO's Reliability Network Upgrades required for the AV Solar Ranch One Project to begin Commercial Operation and the Participating TO will use

Reasonable Efforts to expedite the schedule to comply with the requested In-Service Date.

If the Interconnection Customer suspends work pursuant to Article 5.16 of the LGIA, then all milestones for each Party set forth in this Appendix B shall be suspended during the suspension period except for the milestones requiring posting of the Interconnection Financial Security and work for the Network Upgrades common to other generating facilities which generating facilities are not the subject of this LGIA. Upon the Interconnection Customer's request to recommence the work, the Parties shall negotiate in good faith new revised milestone dates for each milestone, taking into account the period of suspension and necessary re-studies, if required. Appendix B and any terms and conditions associated with the estimated costs and payment schedule, if necessary, shall be amended following the establishment of such revised milestone dates.

The Interconnection Customer also understands and agrees that the method of service required to interconnect the AV Solar One Project may require re-evaluation due to the suspension of the project and changes to the Participating TO's electrical system or addition of new generation.

Appendix C To LGIA

Interconnection Details

- 1. Generating Facility:** The Generating Facility, as studied in the Phase II Interconnection Study, includes, but it is not limited to, all equipment and facilities comprising the proposed 250 MW generating facility located in Kern County, California, as disclosed by the Interconnection Customer in its interconnection application, as may have been amended during the Interconnection Study process, which consists of (i) a total of 150 individual 1,700 kW solar inverters, (ii) 150 pad-mount transformer(s) (34.5/0.4 kV (YG-D), 1.75MVA H-X Impedance Value: 5.75% @ 1.75 MVA), and (iii) two main step-up transformers (230/13.8/34.5 kV (YG-D-YG), 80/107/133 MVA), meters and metering equipment and appurtenant equipment (together the “AV Solar One Project”).

- 2. Interconnection Customer Operational Requirements:**
 - (a) Pursuant to Article 9.4 of the LGIA, the Interconnection Customer shall operate the AV Solar One Project and the Interconnection Customer’s Interconnection Facilities in accordance with the CAISO Tariff, NERC and the Applicable Reliability Council requirements, and Applicable Reliability Standards.

 - (b) The AV Solar One Project shall be operated so as to prevent or protect against the following adverse conditions on the Participating TO’s electric system: inadvertent and unwanted re-energizing of a utility dead line or bus; interconnection while out of synchronization; overcurrent; voltage imbalance; ground faults; generated alternating current frequency outside permitted safe limits; poor power factor or reactive power outside permitted limits; and abnormal waveforms.

- 3. Interconnection Principles:**
 - (a) This LGIA provides for interconnection of a total capacity of 250 MW, resulting from the interconnection of the AV Solar One Project, as described in Section 1 of this Appendix C. The Interconnection Customer acknowledges that if the Interconnection Customer wishes to increase the amount of interconnection capacity provided pursuant to this LGIA, the Interconnection Customer shall be required to submit a new Interconnection Request in accordance with the terms and conditions of the CAISO Tariff.

 - (b) The costs associated with any mitigation measures required to third party transmission systems resulting from the interconnection of the AV Solar One Project to the Participating TO’s electrical system are not reflected in this LGIA. The Participating TO shall have no responsibility to pay costs

associated with any such mitigation measures. If applicable, Interconnection Customer shall enter into an agreement with such third parties to address any required mitigation in accordance with Section 12.4 of the LGIP.

- (c) In the event the Participating TO's Interconnection Facilities are utilized to provide retail service to the Interconnection Customer in addition to the wholesale Interconnection service provided herein, and the Interconnection Customer fails to make payment for such retail service in accordance with the Participating TO's applicable retail tariffs, the Participating TO's Interconnection Facilities may be removed from service to the Interconnection Customer, subject to the notice and cure provisions of such retail tariffs, until payment is made by the Interconnection Customer pursuant to such retail tariffs.
- (d) Review by the Participating TO of the electrical specifications, design, construction, operation, or maintenance of the AV Solar One Project or the Interconnection Customer's Interconnection Facilities shall not constitute any representation as to the economic or technical feasibility, operational capability, or reliability of such facilities. The Interconnection Customer shall in no way represent to any third party that any such review by the Participating TO of such facilities, including, but not limited to, any review of the design, construction, operation, or maintenance of such facilities by the Participating TO, is a representation by the Participating TO as to the economic or technical feasibility, operational capability, or reliability of the AV Solar One Project or the Interconnection Customer's Interconnection Facilities.
- (e) To the extent not already performed, the Interconnection Customer shall complete and receive approval for all environmental impact studies necessary for the construction, operation, and maintenance of the Participating TO's Interconnection Facilities, Distribution Upgrades and Reliability Network Upgrades described in Appendix A of this LGIA. Interconnection Customer shall provide the results of such studies and approvals to Participating TO for use in Participating TO's application(s) to obtain the regulatory approvals required to be obtained by the Participating TO for the construction, operation, and maintenance of the Participating TO's Interconnection Facilities, Distribution Upgrades and Participating TO's Reliability Network Upgrades described in Appendix A of this LGIA.
- (f) The Interconnection Customer is responsible for all costs associated with any necessary relocation of any Participating TO facilities existing as of the Effective Date ("existing Participating TO facilities") which are to be relocated as a result of the AV Solar One Project and acquiring all property rights necessary for the Interconnection Customer's Interconnection Facilities to be constructed under the LGIA, including those required to cross the Participating TO's facilities and property. The relocation of existing

Participating TO facilities or use of Participating TO property rights shall only be permitted upon written agreement between Participating TO and the Interconnection Customer. Any proposed relocation of existing Participating TO facilities or use of existing Participating TO property rights may require a study and/or evaluation, to determine whether such use may be accommodated. Unless the costs of the study are to be paid by a third-party pursuant to Article 15.19.3 of the LGIA, the cost of a study and/or evaluation shall be borne by the Interconnection Customer. The terms and conditions of any such use of Participating TO facilities or property rights would be the subject of a separate agreement.

- (g) This LGIA does not address any requirements for standby power or temporary construction power that the AV Solar One Project may require prior to the In-Service Date of the Interconnection Facilities. Should the AV Solar One Project require standby power or temporary construction power from Participating TO prior to the In-Service Date of the Interconnection Facilities, the Interconnection Customer is responsible to make appropriate arrangements with Participating TO to receive and pay for such retail service.
- (h) The Participating TO acknowledges that the Generating Facility may be financed in whole, or in part, with funds provided under a guarantee by the U.S. Department of Energy (“DOE”) pursuant to the ARRA. Participating TO further acknowledges that the ARRA mandates that projects assisted by and through the Federal government, including, but not limited to, DOE, comply with the Labor Laws. The Participating TO will endeavor to include in all contracts with contractors who provide laborers or mechanics for the construction of the Participating TO’s Interconnection Facilities and Network Upgrades provisions substantially similar to those in the Labor Laws. The Interconnection Customer acknowledges that the Participating TO does not, by this LGIA, accept any liability for any losses suffered or gains not realized by the Interconnection Customer, or its agents, employees, or assigns, due to a failure by any party to comply with the Labor Laws.

4. Cluster Study Group:

- (a) The AV Solar One Project participated in the CAISO’s SCE Northern Bulk System cluster for purposes of assessing impacts to the Participating TO’s electrical system and that portion of the Participating TO’s electrical system that constitutes the CAISO Controlled Grid. The Phase I Interconnection Study was issued on July 24, 2009, and revised on November 20, 2009, and the Phase II Interconnection Study was issued on July 8, 2010.

5. Interconnection Operations:

- (a) The Interconnection Customer shall cause the AV Solar One Project to participate in any SPS required to prevent thermal overloads and unstable

- conditions resulting from outages. Such participation shall be in accordance with applicable FERC regulations, CAISO Tariff provisions and protocols and the requirements of Article 9.7.4 of the LGIA. The Interconnection Customer will not be entitled to any compensation from the Participating TO, pursuant to the LGIA, for loss of generation output when (i) the AV Solar One Project generation is reduced or tripped off-line due to implementation of the SPS; or (ii) such generation output is restricted in the event the SPS becomes inoperable. Pursuant to Good Utility Practice, the Participating TO will provide the Interconnection Customer advance notice of any required SPS beyond that which has already been identified in the Phase II Interconnection Study and this LGIA.
- (b) The Interconnection Customer shall cause the AV Solar One Project to participate in CAISO congestion management in accordance with CAISO Tariff and Scheduling Protocols.
 - (c) Following outages of the Interconnection Facilities or the AV Solar One Project, the Interconnection Customer shall not energize the AV Solar One Project for any reason without specific permission from the Participating TO's and the CAISO's operations personnel. Such permission shall not be unreasonably withheld.
 - (d) The Interconnection Customer shall maintain operating communications with the Participating TO's designated switching center. The operating communications shall include, but not be limited to, system parallel operation or separation, scheduled and unscheduled outages, equipment clearances, protective relay operations, and levels of operating voltage and reactive power.
 - (e) The Interconnection Customer has elected for the AV Solar One project to have Full Capacity Deliverability Status as such term is defined in the CAISO Tariff. Interconnection Customer acknowledges and understands that (i) attainment of Full Capacity Deliverability Status may depend on completion of the Participating TO's Delivery Network Upgrades and other new transmission facilities that the Phase II Interconnection Study assumed to be in service by the time of the Participating TO's Delivery Network Upgrades construction, and (ii) until attainment of Full Capacity Deliverability Status, the AV Solar One Project will have Energy-Only Deliverability Status as such term is defined in the CAISO Tariff.
 - (f) Additional operational studies may be performed by the Participating TO on an as needed basis to confirm if any of the circuit breaker upgrades or replacements identified in the Phase II Interconnection Study as being triggered by queued ahead projects are required to be advanced in order to accommodate interconnection of the AV Solar One Project. Interconnection Customer shall pay for such studies if they are requested in writing by the

Interconnection Customer. In the event that it is determined by the Participating TO that any such upgrades or replacements are required to be advanced in order to accommodate interconnection of the AV Solar One Project, such advancement shall be addressed in accordance with Section 12.2.2 of the LGIP. Interconnection Customer may commit to pay the costs associated with expediting construction of Network Upgrades to meet the original proposed Commercial Operation Date.

- 6. Compliance with Applicable Reliability Standards:** The Interconnection Customer shall comply with all Applicable Reliability Standards for its Interconnection Customer's Interconnection Facilities and the AV Solar One Project. The Participating TO will not assume any responsibility for complying with mandatory reliability standards for such facilities and offers no opinion whether the Interconnection Customer must register with NERC. If required to register with NERC, the Interconnection Customer shall be responsible for complying with all Applicable Reliability Standards for its Interconnection Customer's Interconnection Facilities up to the Point of Change of Ownership as described in Section 5 of Appendix A of this LGIA.

Appendix D To LGIA

Security Arrangements Details

Infrastructure security of CAISO Controlled Grid equipment and operations and control hardware and software is essential to ensure day-to-day CAISO Controlled Grid reliability and operational security. FERC will expect the CAISO, all Participating TOs, market participants, and Interconnection Customers interconnected to the CAISO Controlled Grid to comply with the recommendations offered by the President's Critical Infrastructure Protection Board and, eventually, best practice recommendations from the electric reliability authority. All public utilities will be expected to meet basic standards for system infrastructure and operational security, including physical, operational, and cyber-security practices.

The Interconnection Customer shall meet the requirements for security implemented pursuant to the CAISO Tariff, including the CAISO's standards for information security posted on the CAISO's internet web site at the following internet address: <http://www.caiso.com/271f/271fcbd45ca60.html>.

**Appendix E
To LGIA**

Commercial Operation Date

[This Appendix E sets forth a form of letter to be provided by the Interconnection Customer to the CAISO and Participating TO to provide formal notice of the Commercial Operation Date of a phase of a Generating Facility.]

[Date]

Mr. Stephen Ruty
Manager of Grid Assets
California Independent System Operator Corporation
151 Blue Ravine Road
Folsom, CA 95630

Mr. Robert Kott
Manager of Model and Contract Implementation
California Independent System Operator Corporation
151 Blue Ravine Road
Folsom, CA 95630

Mr. William Law
Manager, Grid Contracts Administration and Billing
Southern California Edison Company
P. O. Box 800
2244 Walnut Grove Avenue
Rosemead, California 91770

Re: Commercial Operation Date of Phase _____ of the Generating Facility

Dear Messrs. Ruty, Kott, and Law:

On **[Date]** **[Interconnection Customer]** completed project phase _____ of the Generating Facility. This letter confirms that the Commercial Operation Date of project phase _____ of the Generating Facility, is **[Date plus one day]** and that **[Interconnection Customer]** provided the CAISO's operations personnel advance notice of its intended Commercial Operation Date no less than five Business Days prior to that date.

Thank you.

[Signature]

[Interconnection Customer Representative]

cc: Linda Wright or Judy Brown

**Appendix F
To LGIA**

Addresses for Delivery of Notices and Billings

Notices:

1. General Notices:

CAISO	Participating TO	Interconnection Customer
<p>Ms. Linda Wright or Judy Brown 151 Blue Ravine Rd. Folsom, CA 95630</p>	<p>Manager, Grid Contracts Administration and Billing P. O. Box 600 Rosemead, CA 91770</p>	<p>AV Solar Ranch 1, LLC Attn: Jim Filippi, Director, Transmission and Interconnection First Solar 353 Sacramento St., Suite 2100 San Francisco, CA 94111 Phone: 415.935.2498 Facsimile: 415.935.2499 Email: Jim.Filippi@firstsolar.com</p> <p>With copies to:</p> <p>Jack Pigott, Director, Project Development First Solar 353 Sacramento St. , Suite 2100 San Francisco, CA 94111 Phone: 415.935.2512 Facsimile: 415.935.2513 Email: Jack.Pigott @firstsolar.com</p> <p>Lisa Bodensteiner, Assistant General Counsel First Solar 1111 Broadway, 4th Floor Oakland, CA 94607 Phone: 510.625-7400 Facsimile: 510.835.1274 Email: Lisa.Bodensteiner@firstsolar.com</p> <p>NextLight Renewable Power, LLC Attn: Robert F. Miller, Vice President & General Counsel 353 Sacramento St., Suite 2100 San Francisco, CA 94111 Phone: 415.935.2500 Facsimile: 415.935.2501 Email: Robert.Miller@firstsolar.com</p>

2. Operating Communications and Notifications:

The CAISO, Participating TO and the Interconnection Customer shall provide for operating communications through their respective designated representatives as follows:

The Parties agree to exchange the following information prior to the Initial Synchronization Date:

CAISO	Participating TO	Interconnection Customer
CAISO Real Time Desk/24 Hour Telephone:	Grid Control Center/24 Hour Telephone:	*Operator Name and/or Title: Control Room Operator *24 Hour Telephone:
Alternate Phone:		*Operation Center Fax. No.: *E-mail:

3. Operational Matters, Force Majeure, and Outage Notices:

CAISO	Participating TO	Interconnection Customer
California ISO Ms. Judy Brown 151 Blue Ravine Rd. Folsom, CA 95630	[To be provided prior to the Initial Synchronization Date]	Mitch Samuelian Director, Power Plant Operations First Solar 350 West Washington Street Tempe, AZ 85281 Phone: 602.384.9538 Facsimile: 602.384.9638 Email: MSamuelian@firstsolar.com

4. For Emergencies:

CAISO	Participating TO	Interconnection Customer
California ISO Ms. Judy Brown 151 Blue Ravine Rd. Folsom, CA 95630	[To be provided prior to the Initial Synchronization Date]	Mitch Samuelian Director, Power Plant Operations First Solar 350 West Washington Street Tempe, AZ 85281 Phone: 602.384.9538 Facsimile: 602.384.9638 Email: MSamuelian@firstsolar.com

5. Billing and Payments:

CAISO	Participating TO	Interconnection Customer
Finance Dept. Mr. Dennis Estrada 151 Blue Ravine Rd. Folsom, CA 95630	Manager, Grid Contracts Administration and Billing P. O. Box 600 Rosemead, CA 91770	First Solar Accounts Payable 28101 Cedar Park Blvd Perrysburgh, OH 43551 With a copy to: AV Solar Ranch 1, LLC Attn: Jim Filippi, Director, Transmission and Interconnection First Solar Development, Incorporated 353 Sacramento St. Suite 2100 San Francisco, CA 94111 Phone: 415.935.2498 Facsimile: 415.935.2499 Email: Jim.Filippi@firstsolar.com

6. Alternate Forms of Delivery of Notices (telephone, facsimile or e-mail):

CAISO	Participating TO	Interconnection Customer
lwright@caiso.com	Manager, Grid Contracts Administration and Billing Tel: (626) 302-9640 Fax: (626) 302-1152	AV Solar Ranch 1, LLC Attn: Jim Filippi, Director, Transmission and Interconnection First Solar 353 Sacramento St. Suite 2100 San Francisco, CA 94111 Phone: 415.935.2498 Facsimile: 415.935.2499 Email: Jim.Filippi@firstsolar.com Jack Pigott, Director, Project Development First Solar 353 Sacramento St. Suite 2100 San Francisco, CA 94111 Phone: 415.935.2512 Facsimile: 415.935.2513 Email: Jack.Pigott@firstsolar.com

**Appendix G
To LGIA**

**Interconnection Customer's Proportional Share of Costs
of Network Upgrades for Applicable Project Group**

Upgrades	Type	Needed For	Total Cost (\$1000)	Cost Share	Allocated Cost (\$1000)
Whirlwind 2nd & 3rd Bank	Delivery	Normal overload on Whirlwind 500/230 kV bank No. 1	\$109,961	19.00%	\$20,893
Whirlwind T-1 SPS	Reliability	T-1 overload on Whirlwind 500/230 kV banks	\$939	16.13%	\$151
Whirlwind Bus Expansion	Reliability	Support physical interconnection of the projects	\$4,282	16.13%	\$691
Vincent Circuit Breaker	Reliability	Short circuit duty mitigation	\$18,016	9.13%	\$1,645
Plan of Service	Reliability	Interconnection and Power Systems Controls	\$2,745	100%	\$2,745
Total Allocated Cost for Network Upgrades					\$26,125

All amounts above are shown in nominal dollars

Appendix H To LGIA

INTERCONNECTION REQUIREMENTS FOR AN ASYNCHRONOUS GENERATING FACILITY

Appendix H sets forth interconnection requirements specific to all Asynchronous Generating Facilities. Existing individual generating units of an Asynchronous Generating Facility that are, or have been, interconnected to the CAISO Controlled Grid at the same location are exempt from the requirements of this Appendix H for the remaining life of the existing generating unit. Generating units that are replaced, however, shall meet the requirements of this Appendix H.

A. Technical Requirements Applicable to Asynchronous Generating Facilities

i. Low Voltage Ride-Through (LVRT) Capability

An Asynchronous Generating Facility shall be able to remain online during voltage disturbances up to the time periods and associated voltage levels set forth in the requirements below.

1. An Asynchronous Generating Facility shall remain online for the voltage disturbance caused by any fault on the transmission grid, or within the Asynchronous Generating Facility between the Point of Interconnection and the high voltage terminals of the Asynchronous Generating Facility's step up transformer, having a duration equal to the lesser of the normal three-phase fault clearing time (4-9 cycles) or one-hundred fifty (150) milliseconds, plus any subsequent post-fault voltage recovery to the final steady-state post-fault voltage, unless clearing the fault effectively disconnects the generator from the system. Clearing time shall be based on the maximum normal clearing time associated with any three-phase fault location that reduces the voltage at the Asynchronous Generating Facility's Point of Interconnection to 0.2 per-unit of nominal voltage or less, independent of any fault current contribution from the Asynchronous Generating Facility.
2. An Asynchronous Generating Facility shall remain online for any voltage disturbance caused by a single-phase fault on the transmission grid, or within the Asynchronous Generating Facility between the Point of Interconnection and the high voltage terminals of the Asynchronous Generating Facility's step up transformer with delayed clearing, plus any subsequent post-fault voltage recovery to the final steady-state post-fault voltage, unless clearing the fault effectively disconnects the generator from the system. Clearing time shall be based on the maximum backup clearing time associated with a single point of failure (protection or breaker failure) for any single-phase fault location that reduces any phase-to-ground or phase-to-phase voltage at the Asynchronous Generating Facility's Point of Interconnection to 0.2 per-unit of nominal

voltage or less, independent of any fault current contribution from the Asynchronous Generating Facility.

3. Remaining on-line shall be defined as continuous connection between the Point of Interconnection and the Asynchronous Generating Facility's units, without any mechanical isolation. Asynchronous Generating Facilities may cease to inject current into the transmission grid during a fault.
4. The Asynchronous Generating Facility is not required to remain on line during multi-phased faults exceeding the duration described in Section A.i.1 of this Appendix H or single-phase faults exceeding the duration described in Section A.i.2 of this Appendix H.
5. The requirements of this Section A.i. of this Appendix H do not apply to faults that occur between the Asynchronous Generating Facility's terminals and the high side of the step-up transformer to the high-voltage transmission system.
6. Asynchronous Generating Facilities may be tripped after the fault period if this action is intended as part of a special protection system.
7. Asynchronous Generating Facilities may meet the requirements of this Section A.i of this Appendix H through the performance of the generating units or by installing additional equipment within the Asynchronous Generating Facility, or by a combination of generating unit performance and additional equipment.
8. The provisions of this Section A.i of this Appendix H apply only if the voltage at the Point of Interconnection has remained within the range of 0.9 and 1.10 per-unit of nominal voltage for the preceding two seconds, excluding any sub-cycle transient deviations.

The requirements of this Section A.i in this Appendix H shall not apply to any Asynchronous Generating Facility that can demonstrate to the CAISO a binding commitment, as of July 3, 2010, to purchase inverters for thirty (30) percent or more of the Generating Facility's maximum Generating Facility Capacity that are incapable of complying with the requirements of this Section A.i in this Appendix H. The Interconnection Customer must include a statement from the inverter manufacturer confirming the inability to comply with this requirement in addition to any information requested by the CAISO to determine the applicability of this exemption.

ii. Frequency Disturbance Ride-Through Capability

An Asynchronous Generating Facility shall comply with the off nominal frequency requirements set forth in the WECC Under Frequency Load Shedding Relay Application Guide or successor requirements as they may be amended from time to time.

iii. Power Factor Design and Operating Requirements (Reactive Power)

An Asynchronous Generating Facility shall operate within a power factor within the range of 0.95 leading to 0.95 lagging, measured at the Point of Interconnection as defined in this LGIA in order to maintain a specified voltage schedule, if the Phase II Interconnection Study shows that such a requirement is necessary to ensure safety or reliability. The power factor range standard can be met by using, for example, power electronics designed to supply this level of reactive capability (taking into account any limitations due to voltage level, real power output, etc.) or fixed and switched capacitors, or a combination of the two, if agreed to by the Participating TO and CAISO. The Interconnection Customer shall not disable power factor equipment while the Asynchronous Generating Facility is in operation. Asynchronous Generating Facilities shall also be able to provide sufficient dynamic voltage support in lieu of the power system stabilizer and automatic voltage regulation at the generator excitation system if the Phase II Interconnection Study shows this to be required for system safety or reliability.

iv. Supervisory Control and Data Acquisition (SCADA) and Automated Dispatch System (ADS) Capability

An Asynchronous Generating Facility shall provide SCADA capability to transmit data and receive instructions from the Participating TO and CAISO to protect system reliability. The Participating TO and CAISO and the Asynchronous Generating Facility Interconnection Customer shall determine what SCADA information is essential for the proposed Asynchronous Generating Facility, taking into account the size of the plant and its characteristics, location, and importance in maintaining generation resource adequacy and transmission system reliability.

v. Power System Stabilizers (PSS)

Power system stabilizers are not required for Asynchronous Generating Facilities.