

# PG&E's 2012 Request Window Proposals

## San Joaquin Valley

Isaac Read  
Transmission System Planning  
PG&E

September 27, 2012





# Transmission Projects Overview

## Projects Seeking CAISO Approval

- Kearney-Caruthers 70 kV Line Reconductor
- Midway-Temblor 115 kV Line Reconductor and Voltage Support
- Kearney-Kerman 70 kV Line Reconductor
- Los Banos-Livingston Jct-Canal 70 kV Switch Replacement
- Gregg-Herndon #2 230 kV Line Circuit Breaker Upgrade
- Kearney 230/70 kV Transformer Addition
- Arco 230/70 kV Transformer Addition
- Cressey-Gallo 115 kV Line
- Northern Fresno 115 kV Area Reinforcement
- Midway-Wheeler Ridge 230 kV Capacity Increase



# Kearney-Caruthers 70 kV Line Reconductor

## Background

- Caruthers 70 kV substation is served by two 70 kV lines. The primary source comes from Kearney substation to the north, and its secondary normally open source is from Henrietta and Kingsburg to the south.
- The secondary source cannot currently support the Caruthers load during summer peak normal or emergency conditions.

## Assessment

- Under normal operating conditions (N-0), the Kearney-Caruthers 70 kV line is projected to exceed the 3/0 CU conductor normal rating during summer peak conditions.

## Scope

- This project proposes to replace roughly 12 miles limiting conductor on the Kearney-Caruthers 70 kV line.

## Other Alternatives Considered

- Status Quo

## In Service Date

- May 2016

## Cost

- \$13M - \$20M

# Kearney-Caruthers 70 kV Line Reconductor

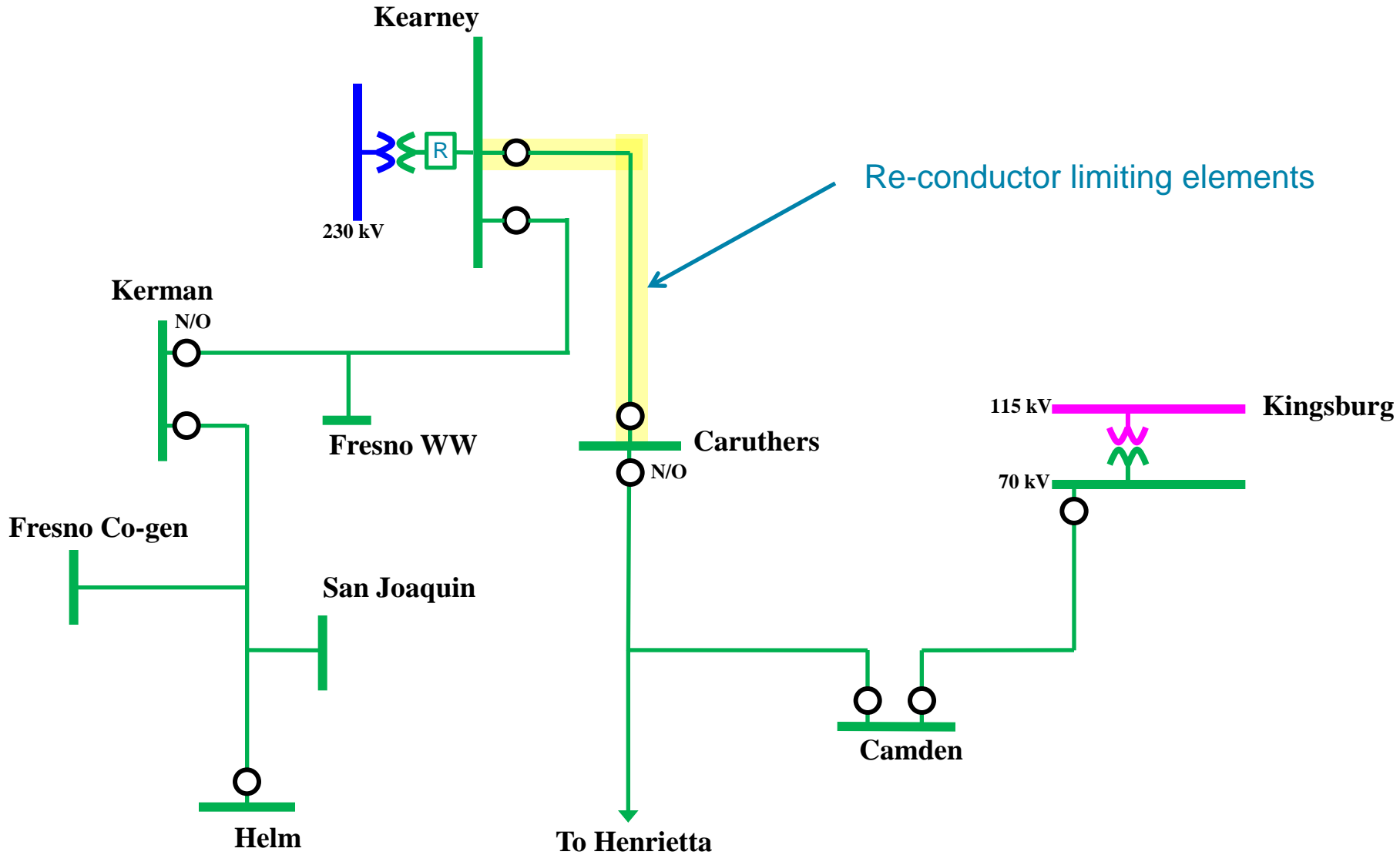



# Midway-Temblor 115 kV Line Reconductor and Voltage Support

## Background

- The Midway-Temblor 115 kV line is the only 115 kV tie-line between the Kern and Los Padres areas, from Midway to San Luis Obispo substations respectively.
- High flows from Midway to San Luis Obispo substation is projected under summer peak conditions on this 115 kV line.

## Assessment

- An outage of the Midway-Temblor 115 kV line with generation offline in the local area (N-1/G-1) causes low voltages in the Temblor 115 kV area in the order of 0.77 pu.
- Additionally, with generation offline alone in the Temblor 115 kV area the Midway-Temblor 115 kV line is projected to exceed its 336.4 AAC rating under summer peak conditions.

## Scope

- This project proposes to replace roughly 15 miles of limiting conductor on the Midway-Temblor 115 kV line, and install 40 MVAR of reactive support at Temblor 115 kV substation.

## Other Alternatives Considered

- Status Quo
- McKittrick 115 kV switching station and Temblor-McKittrick 115 kV line addition

## In Service Date

- May 2018

## Cost

- \$25M - \$35M



# Midway-Temblor 115 kV Line Reconductor and Voltage Support

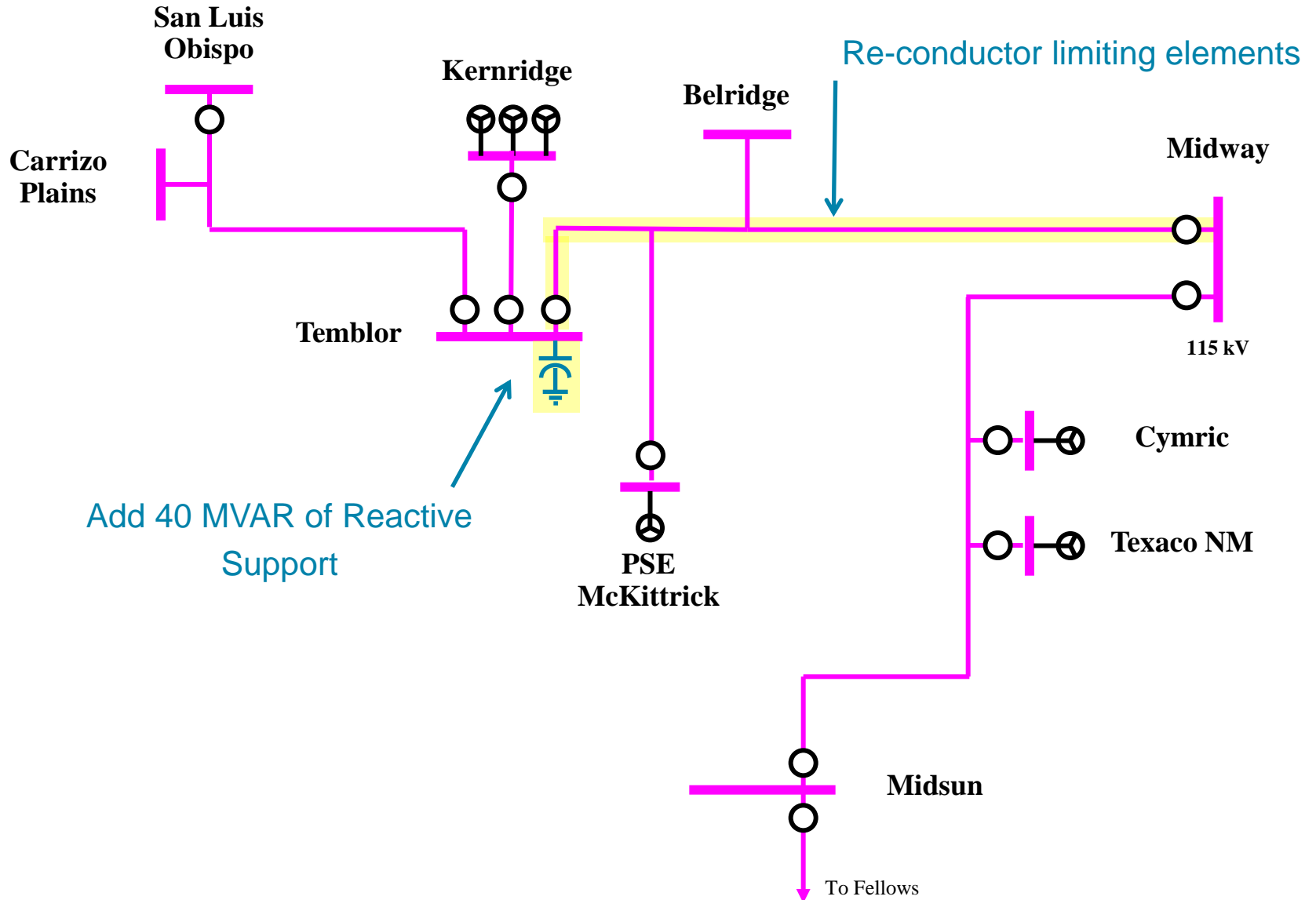



# Kearney-Kerman 70 kV Line Reconductor

## Background

- Kerman 70 kV substation is served by two 70 kV lines. The primary source comes from Helm substation to the southwest, and its secondary normally open source is from Kearney substation to the northeast.
- For an outage of the Helm-Kerman 70 kV line, automatics at Kerman 70 kV substation will switch its source to the Kearney-Kerman 70 kV line. The Kearney-Kerman 70 kV line is limited by 3/0 CU.

## Assessment

- An outage of the Helm-Kerman 70 kV Line (N-1) during summer peak conditions could result in a thermal overload on the Kearney-Kerman 70 kV line following automatic operations at Kerman substation.

## Scope

- This project proposes to replace roughly 11 miles of limiting conductor on the Kearney-Kerman 70 kV line.

## Other Alternatives Considered

- Status Quo
- New Kearney-Kerman-Biola 70 kV line

## In Service Date

- May 2016

## Cost

- \$12M - \$18M

# Kearney-Kerman 70 kV Line Reconductor

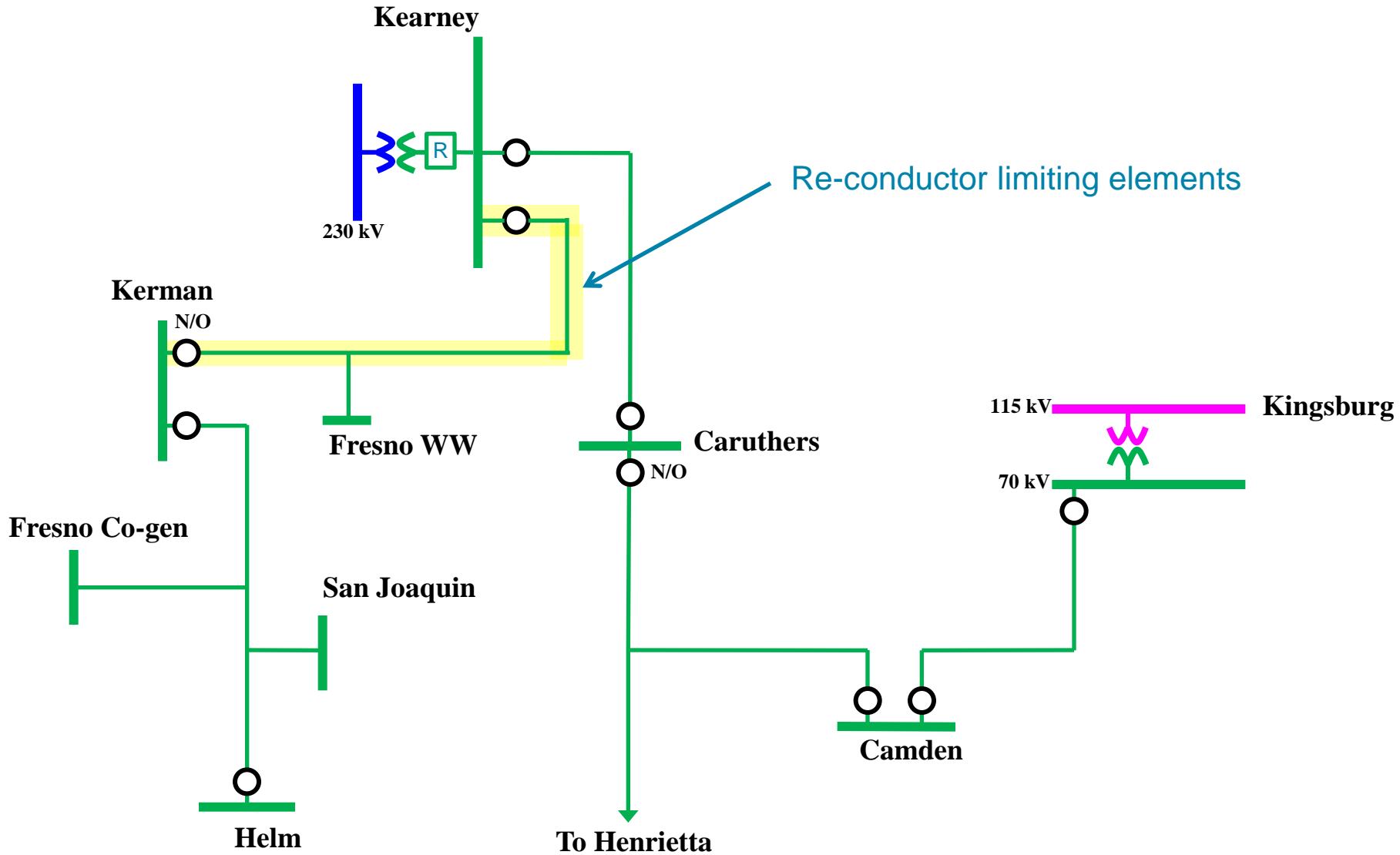





# Los Banos-Livingston Jct-Canal Switch Replacement

## Background

- The Los Banos-Livingston Jct-Canal 70 kV line is one of three 70 kV lines serving the Canal 70 kV substation which provides electricity to a large portion of the City of Los Banos.
- The line rating is currently limited by two 600 Amp transmission line switches, which are decreasing the line rating by 31 Amps and 142 Amps for summer normal and summer emergency ratings, respectively.

## Assessment

- An outage of the Oro Loma 115/70 kV transformer (N-1) during summer peak conditions could result in a thermal overload on the two limiting Los Banos-Livingston Jct-Canal 70 kV transmission line switches.

## Scope

- This project proposes to replace the two 600 Amp 70 kV transmission line switches, with switches capable of greater than 800 Amps.

## Other Alternatives Considered

- Status Quo

## In Service Date

- May 2015

## Cost

- \$0.5M - \$1M



# Los Banos-Livingston Jct-Canal Switch Replacement

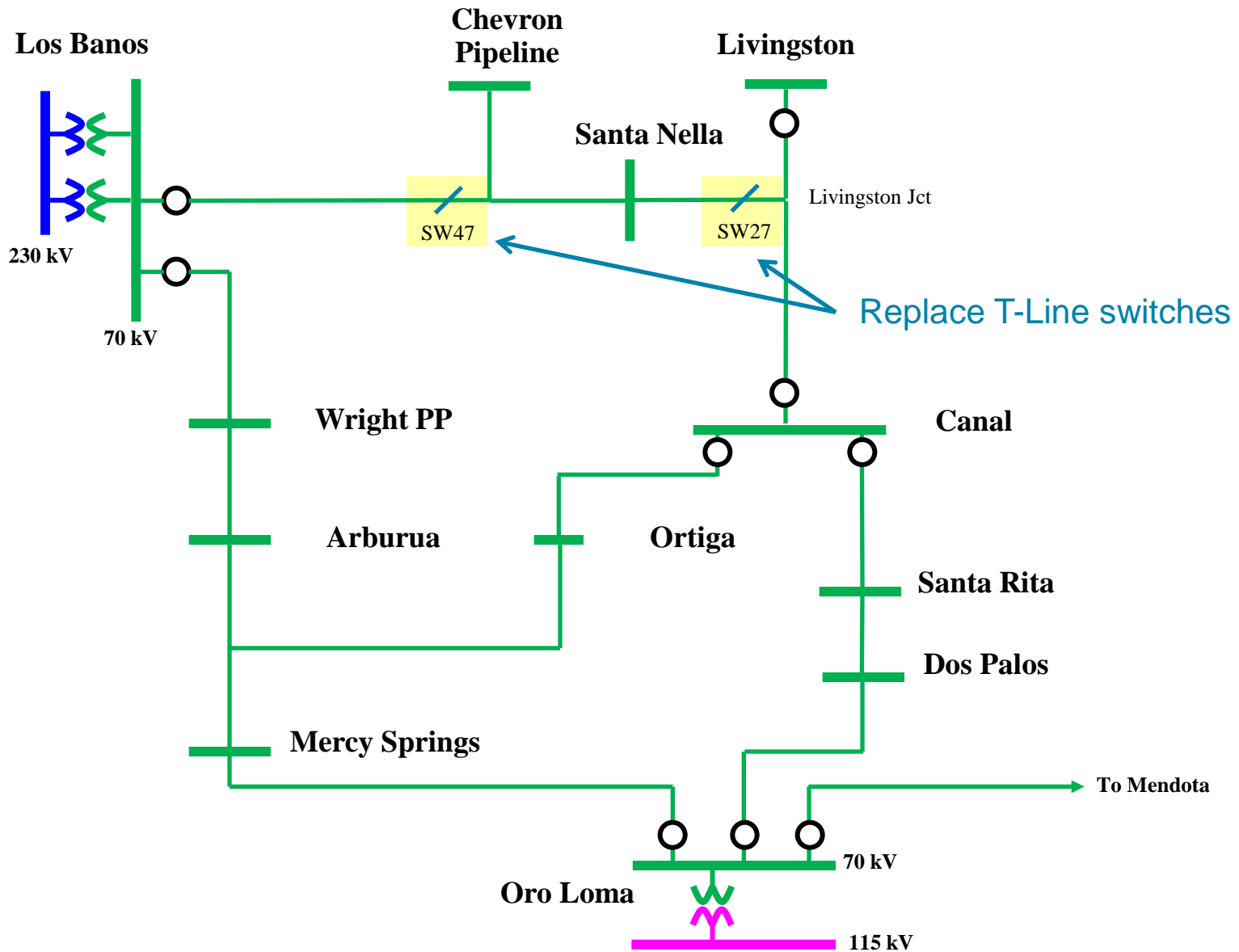



# Gregg-Herndon #2 230 kV Line Circuit Breaker Upgrade

## Background

- The Gregg-Herndon 230 kV lines cross the San Joaquin River and provide two direct connections between Gregg and Herndon substations, these lines are critical to Helms Pumped Storage Plant operation, and for providing power to the Fresno 115 kV system at Herndon substation.
- The Gregg-Herndon #2 230 kV line is limited to 1600 Amps by Herndon circuit breaker 262 and its associated terminal equipment.

## Assessment

- An outage of the Gregg-Ashlan and Gregg-Herndon #1 230 kV lines (N-1-1) during summer peak conditions could result in a thermal overload on the remaining Gregg-Herndon #2 230 kV Line due to limitations on the Herndon circuit breaker and terminal equipment.

## Scope

- This project proposes to replace circuit breaker 262, and any limiting terminal equipment at Herndon substation on the Gregg-Herndon #2 230 kV Line. This will increase the line rating .

## Other Alternatives Considered

- Status Quo

## In Service Date

- May 2015

## Cost

- \$1M - \$2M



# Gregg-Herndon #2 230 kV Line Circuit Breaker Upgrade

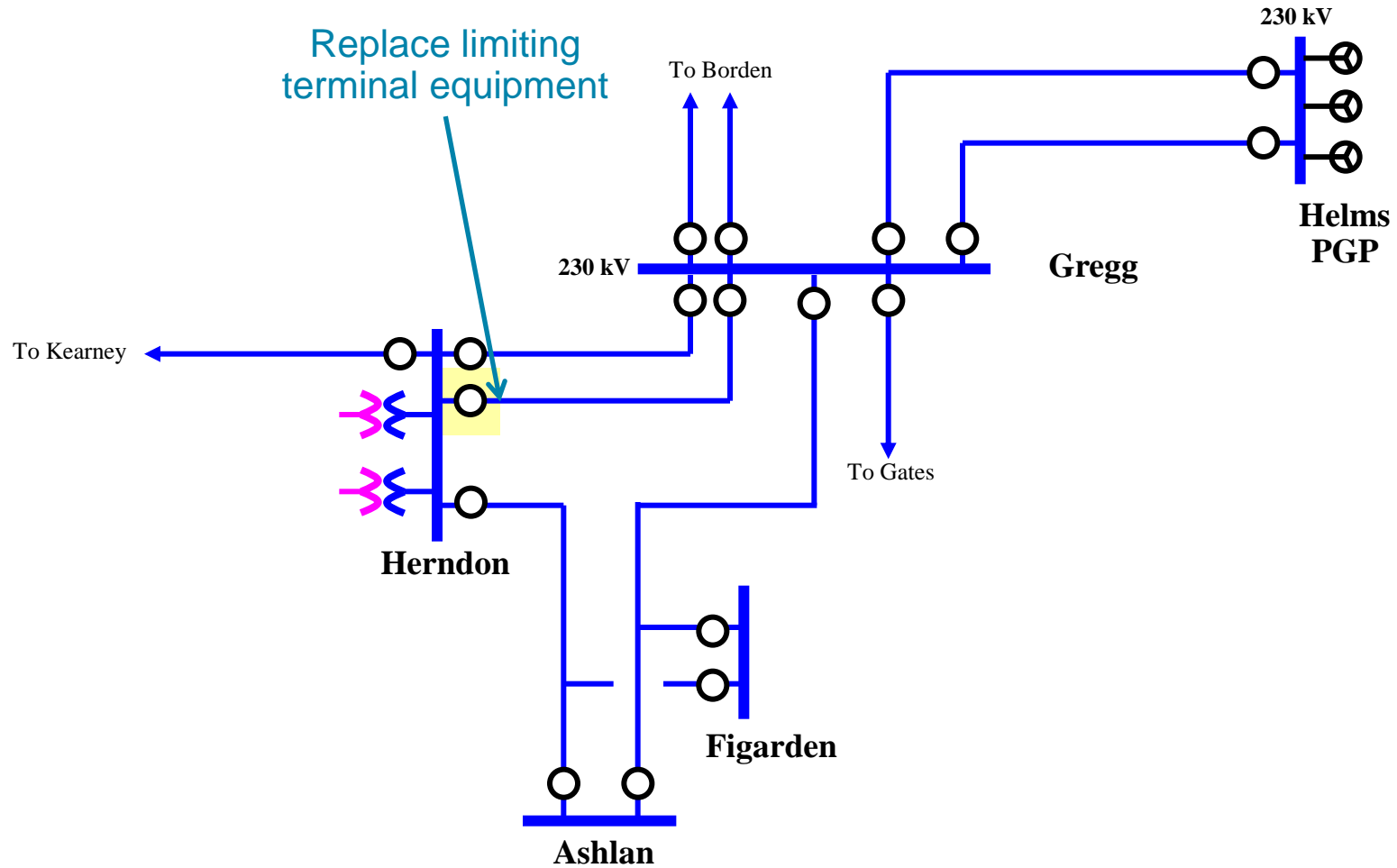



# Kearney 230/70 kV Transformer Addition Project <sup>13</sup>

## Background

- Kearney, located in Fresno County consists of one 230/70 kV transformer. The Transformer serves the local 70 kV transmission system composed of Kearney, Biola, Bowles and Caruthers substations, and Fresno Waste Water large load customer.

## Assessment

- An outage of Kearney Transformer No. 2 results in a sustained outage to all customers (approximately 16,000 customers ,101MW), served via the local 70 kV transmission system.
- Existing transformer maintenance issues due to the radial load.

## Scope

- Install a new 230/70 kV, 200 MVA transformer at Kearney Substation
- Build a four-element 230 kV ring bus
- Extend the 70 kV bus.

## Other Alternatives Considered

- Status Quo
- Network the 70 kV system

## In-Service Date

- December 2015

## Cost

- \$36M - \$38M

## Benefits

- The addition of a second transmission transformer at Kearney Substation would provide the needed reliability for electric customers in the area and will provide system redundancy in the event of a transformer outage or during maintenance.
- The BCR is 1.8

# Existing Single Line Diagram

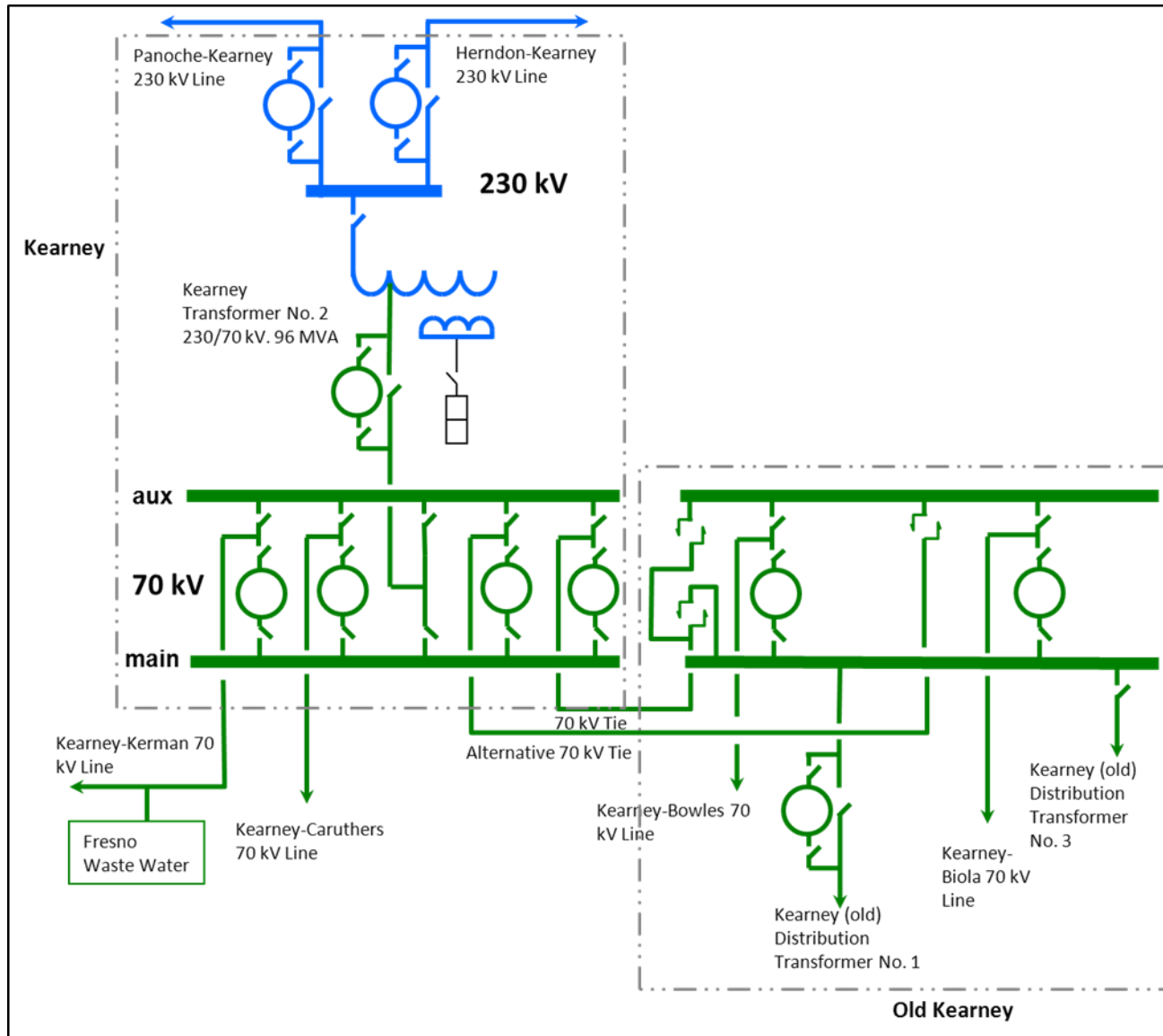

# Proposed Single Line Diagram

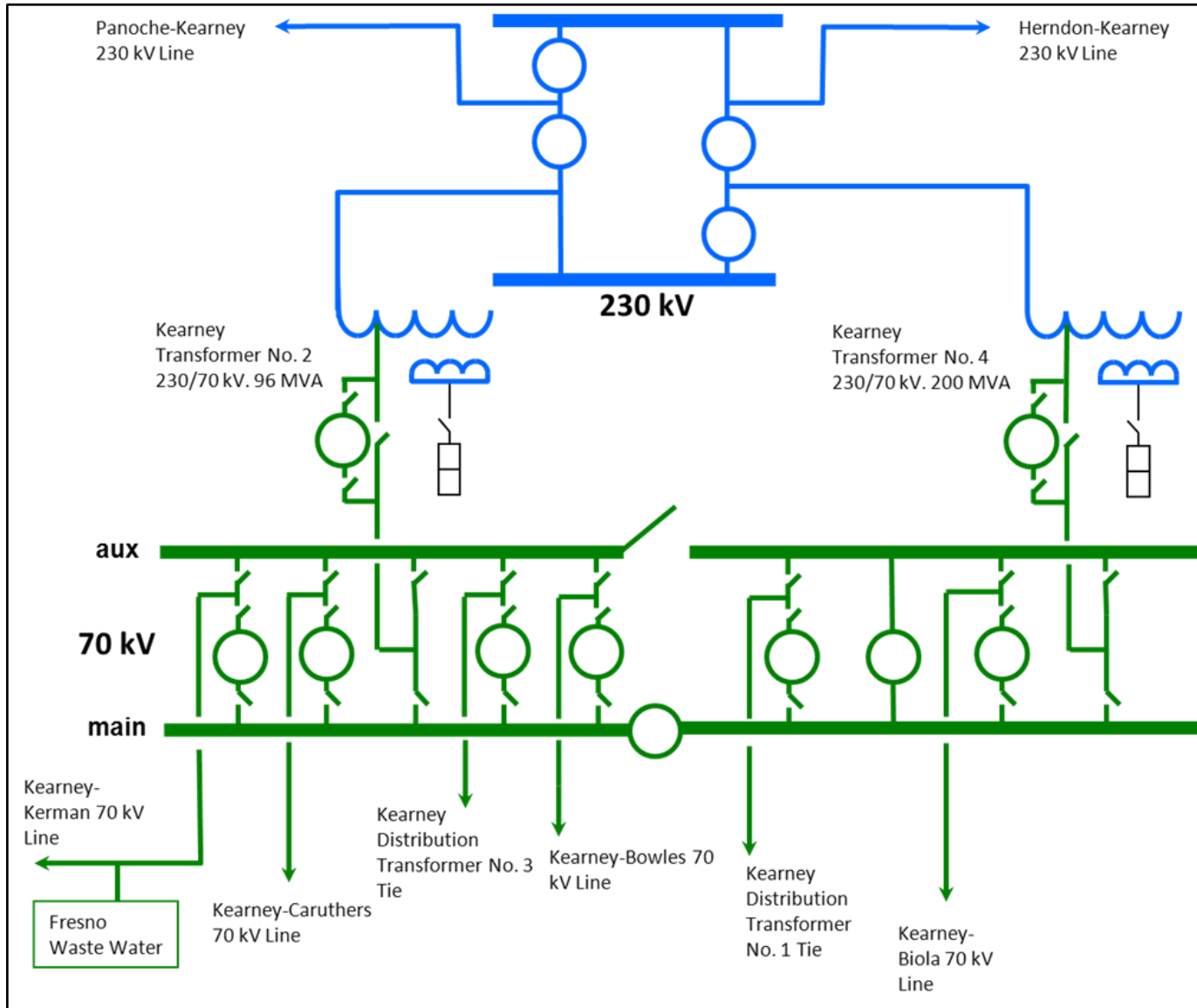



# Arco 230/70 kV Transformer No. 2 Project

## Background

- Arco, located in Kern County, consists of a single 230/70 kV transformer bank serving approximately 103 MW of radial load and 3,200 customers . It consists of three single-phase 230/70 kV , 44.8 MVA transformer units

## Assessment

- An outage of Arco 230/70 kV results in a sustained outage to all of the customers served via the local 70 kV transmission system.
- Existing transformer maintenance issues due to the radial load.

## Scope

- Install three new single-phase, 230/70 kV, 60 MVA transformers and a 180 MVA, 70 kV voltage regulator at Arco Substation
- Install a 230 kV breaker-and-a-half bus arrangement
- Re-insulate and extend the 70 kV main bus

## Other Alternatives Considered

- Status Quo
- Network the 70 kV system

## In-Service Date

- December 2013

## Cost

- \$15M - \$19M

## Benefits

- The addition of a second transmission transformer at Arco Substation would provide the needed reliability for electric customers in the area and will provide system redundancy in the event of a transformer outage or maintenance.
- The BCR is 1.5



# Existing Single Line Diagram

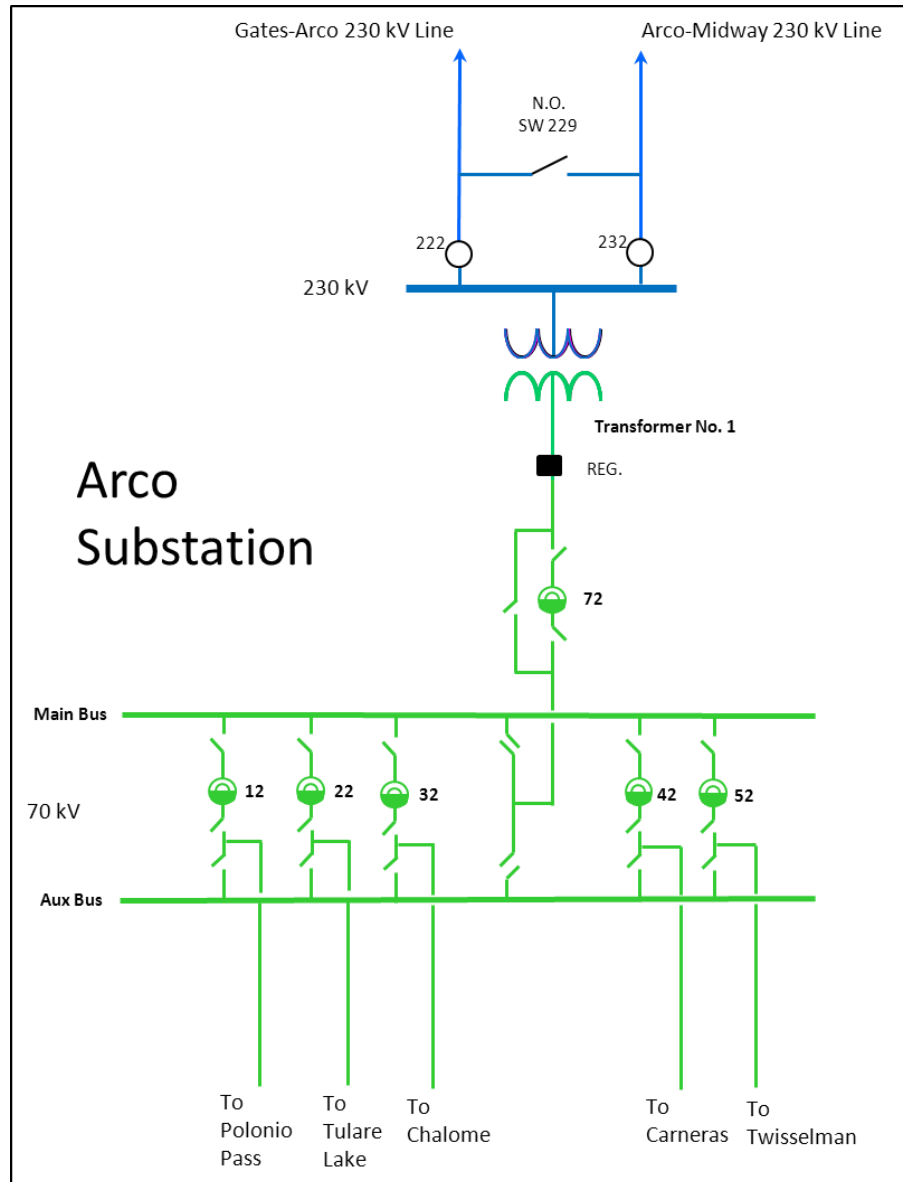

# Proposed Single Line Diagram

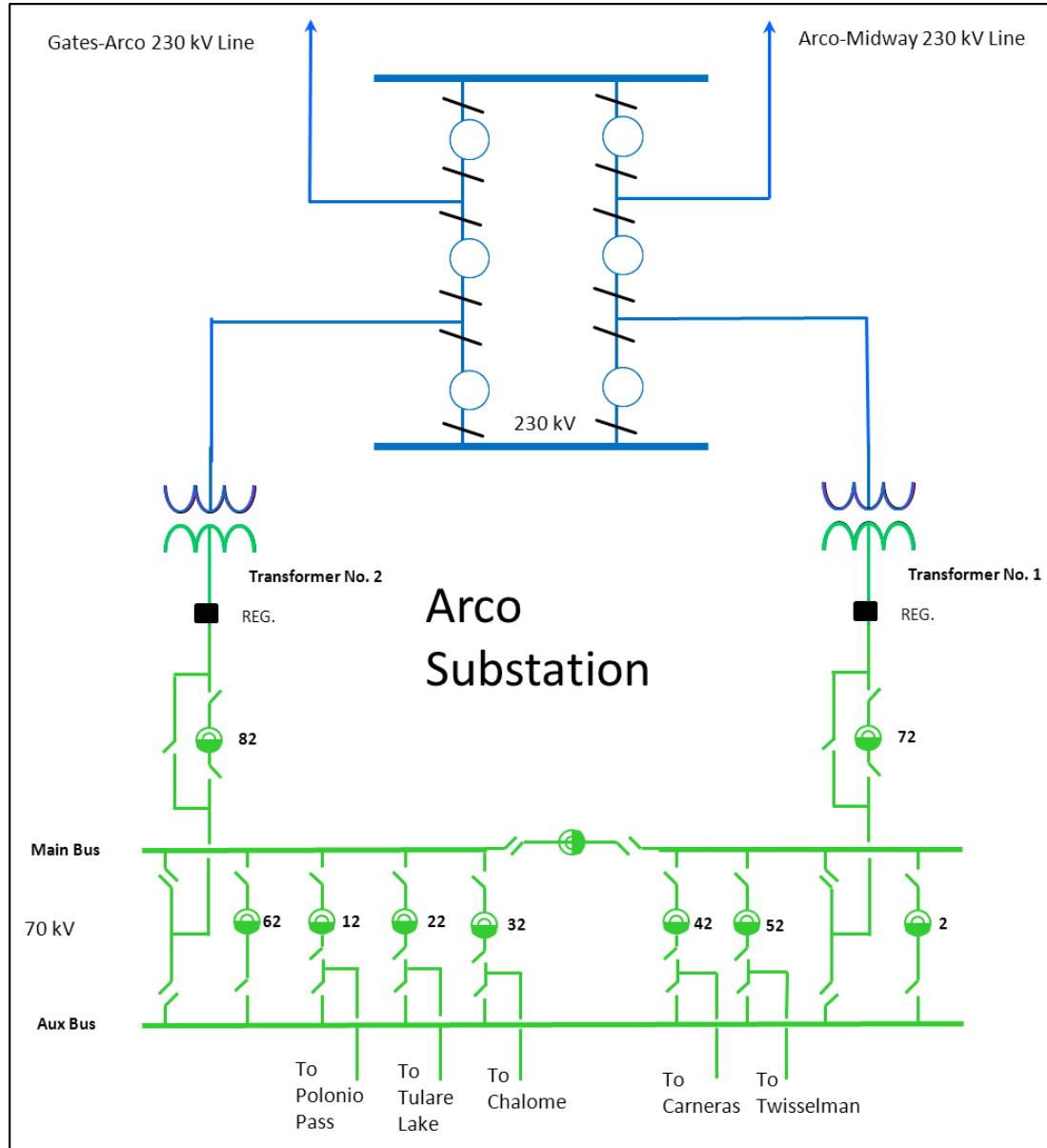



# Cressey – Gallo 115 kV Line Project

## Background

- Cressey, Gallo & Livingston Substations, located in the Northern Merced County, are served from the Atwater-Cressey and Atwater-Merced 115 kV radial Lines, respectively.
- Atwater – Merced 115 kV Line has an average of approximately 2.3 outages per year, for roughly 7 hours per outage. Atwater – Cressey 115 kV Line has an average of approximately 1 outage per year, for roughly 3.5 hours per outage.

## Assessment

- Outage of Atwater – Merced 115 kV Line (15 miles) results in sustained outages to Livingston and Gallo substations (6,100 customers, 30MW)
- Outage of Atwater – Cressey 115 kV Line (6 miles) results in sustained outages to Cressey and Dole substations (3,000 customers, 27MW)
- Existing maintenance issues due to radial loads

## Scope

- This project proposes to build a new 14-mile 115 kV transmission line from Cressey Substation to Gallo Substation.
- Upgrade buses at Cressey and Gallo substations to loop arrangements.

## Other Alternatives Considered

- Status Quo
- Build a new 115 kV line from Atwater to Gallo (over 16 miles)

## In-Service Date

- December 2013

## Cost

- \$15M - \$20M

## Benefits

- This project will improve reliability of electric service for PG&E customers in Cressey, Gallo and Livingston areas
- The BCR is 2.1

# Cressey – Gallo 115 kV Line Project

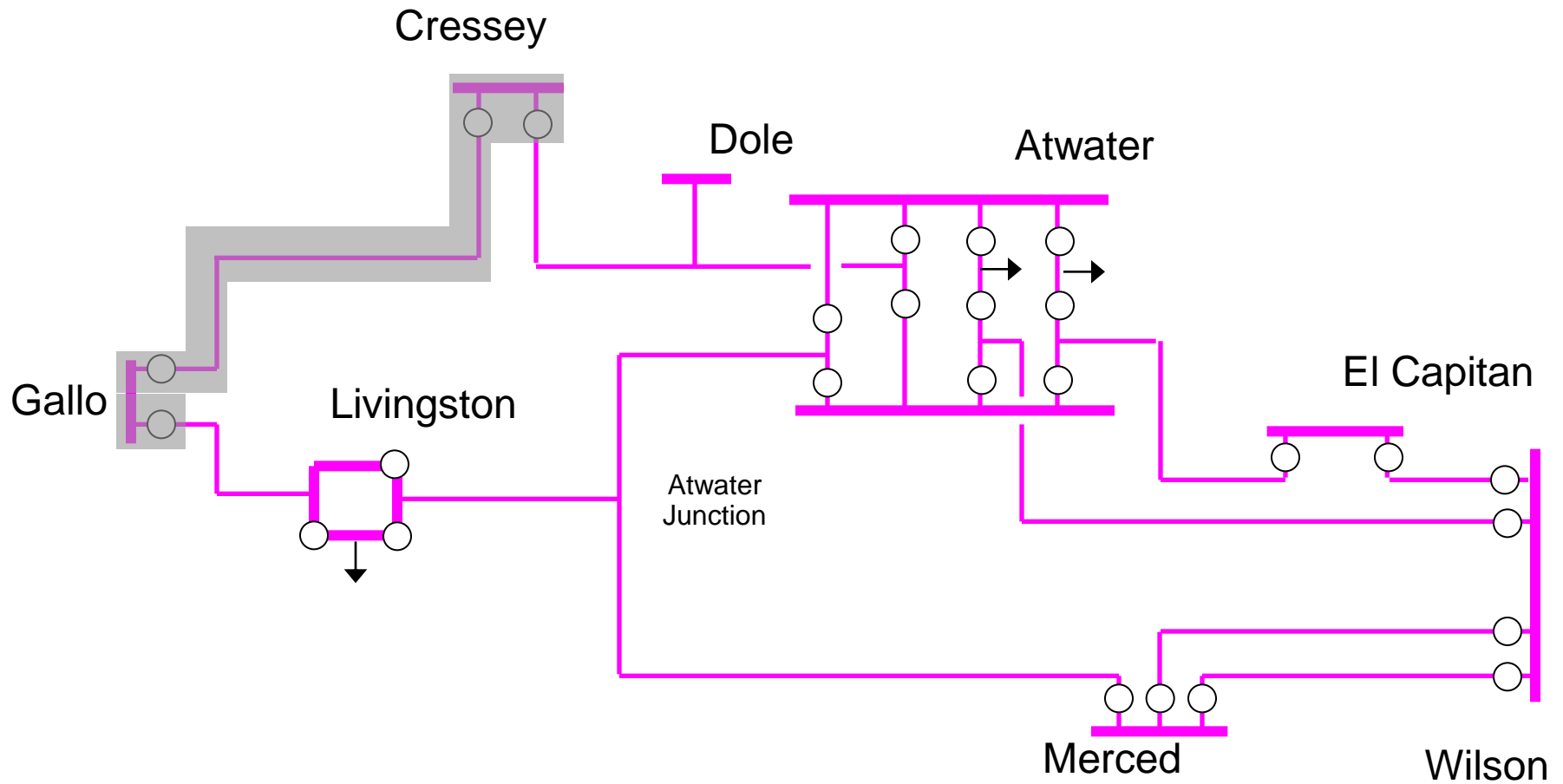



# Northern Fresno 115 kV Area Reinforcement

## Background

- Herndon 230 kV substation is located in Fresno County. Herndon is the main source of power for the northern half of Metropolitan Fresno. McCall 230 kV substation is the main source of power for the southern half of Metro Fresno. Both 230 kV buses are DBSB design.

## Assessment

- This project protects against 20 NERC category C1, C2, C3 and C5 contingencies in the Fresno Metropolitan area, the most severe of which (Herndon and McCall bus tie breaker faults) may lead to facility overloads of up to 200% and/or voltage collapse within the local transmission system.
- Approximately, 550 MW of 1100 MW local load may need to be dropped in order to mitigate the overloads and stabilize voltage condition in the absence of system upgrades.

## Scope

- Build a new 230/115 kV substation north-east of Fresno,
- Reconductor portions of the Kerckhoff-Clovis-Sanger #1 and #2, Herndon-Woodward, and McCall-Sanger #3 115 kV lines, and,
- Install Static Var Compensator (SVC) at the new 230/115 kV substation.

## Other Alternatives Considered

- Status Quo
- 230 kV BAAH and 230/115 kV transformer additions at Herndon and McCall, reconductor the McCall-Sanger #3, the Herndon-Barton and Herndon-Manchester 115 kV lines, and rebuild the Herndon-Woodward-Shepherd 115 kV line as a double circuit tower line.

## In Service Date

- May 2018

## Cost

- \$110M - \$190M

# Northern Fresno 115 kV Area Reinforcement

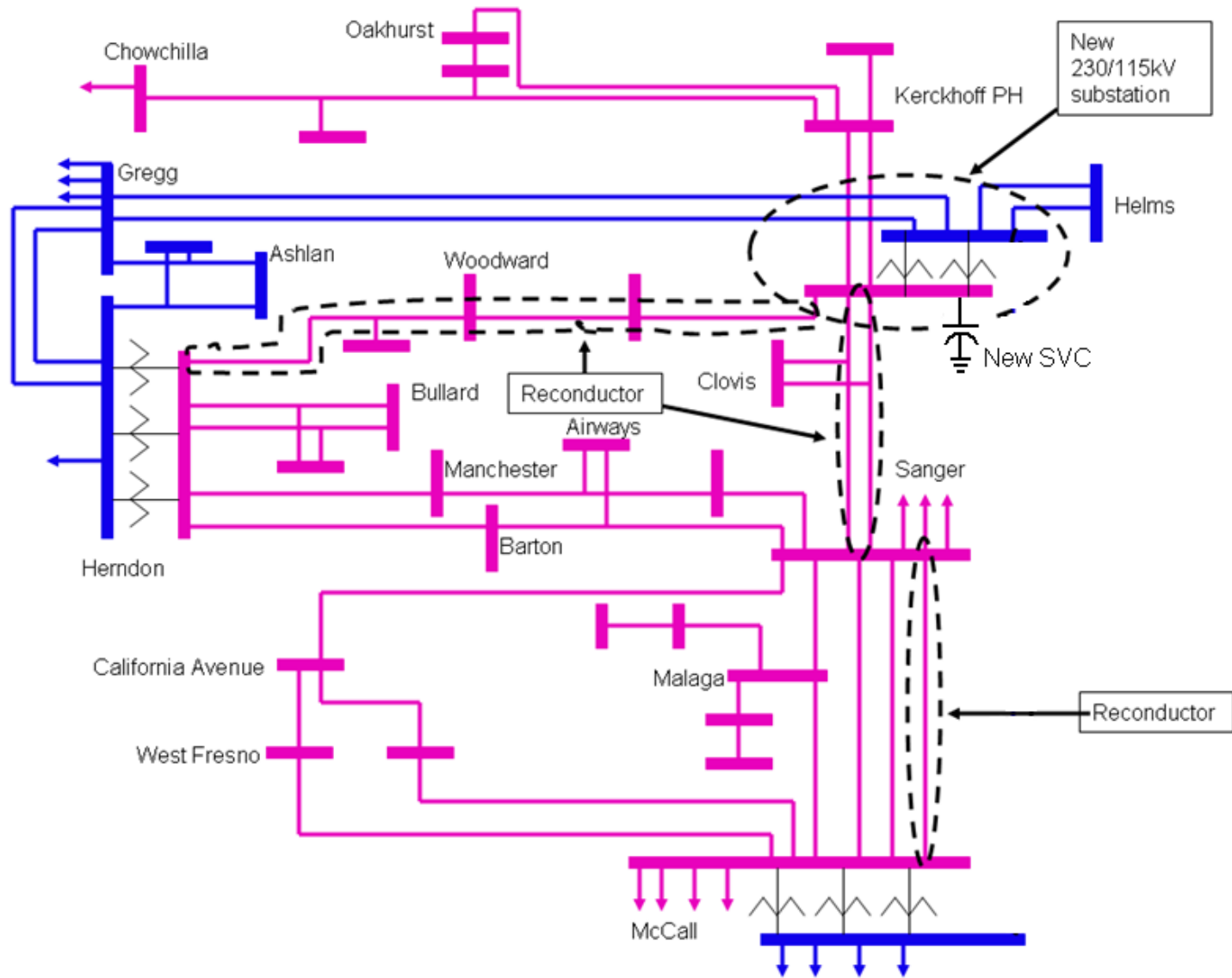



# Midway-Wheeler Ridge 230 kV Capacity Increase

## Background

- Wheeler Ridge 230 kV substation is located in Kern County. Wheeler Ridge substation is supplied by a 50 mile long 230 kV double circuit tower line from Midway substation, and one normally open 115 kV line from Kern PP. Wheeler Ridge is the main source of power for the rural southeast Kern 70 kV area.
- Roughly 500 MW of pumping load is also served by these same 230 kV lines from Midway.

## Assessment

- Load growth in the Wheeler Ridge area has led to transmission capacity limitations between Midway and Wheeler Ridge substations on the two 230 kV lines.
- The Midway-Wheeler Ridge 230 kV line #1 or #2 are projected to exceed their normal ratings under clearance conditions and during summer peak loading conditions for an outage of either line (N-1) with pumping load online.

## Scope

- Phase I: Install three terminal line switches at each tap point along the two Midway-Wheeler Ridge 230 kV lines.
- Phase II: Replace limiting conductor on 96 circuit miles of the Midway-Wheeler Ridge 230 kV lines, from Midway up to the Wind Gap pumping plant tap.

## Other Alternatives Considered

- Status Quo
- Other alternatives involving reinforcing the system or building new facilities from Kern PP are still under evaluation but are expected to be more expensive.

## In Service Date

- Phase I: May 2015
- Phase II: May 2018

## Cost

- Phase I: \$5M - \$8M
- Phase II: \$80M - \$120M

# Midway-Wheeler Ridge 230 kV Capacity Increase

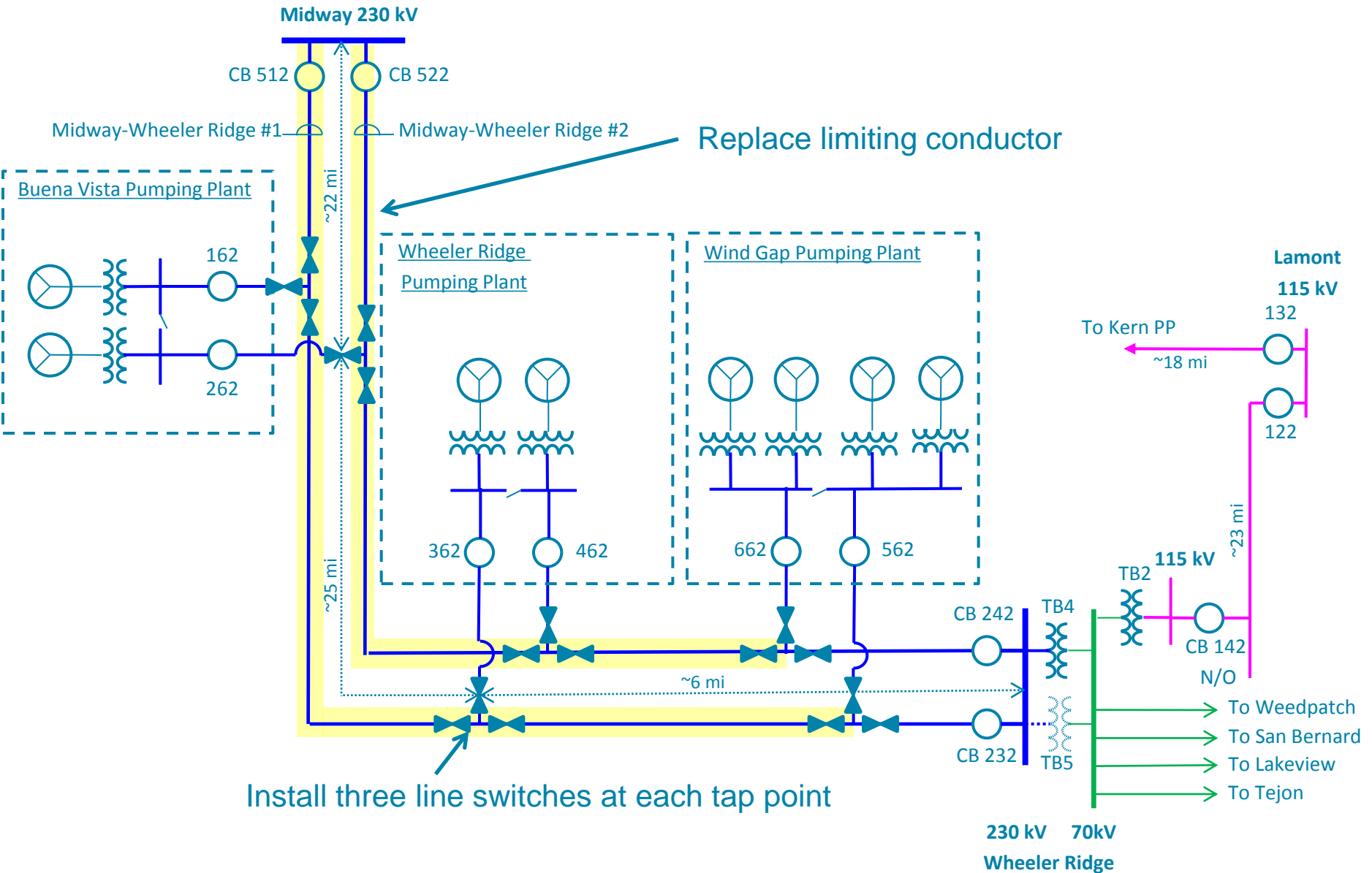





# Conceptual Long Term Plans

## Projects that Require Additional Analysis:

- Panoche-Oro Loma 115 kV Capacity Increase

# Thank You

