2025 Transmission Plan Deliverability Allocation Report



California ISO

4/13/2026

Table of Contents

1. Introduction.....	3
2. Study Assumptions and Methodology.....	3
2.1 Representing Prior TPD Commitments.....	3
2.2 Representing TPD Candidates	4
2.3 Transmission.....	5
2.4 Deliverability Assessment.....	5
3. TPD Allocation Results – SCE Area	6
3.1 Northern Area	6
3.1.1 Pardee – Sylmar Area Constraint.....	6
3.1.2 Moorpark - Pardee Area Constraint	8
3.1.3 North of Magunden Area Constraint	10
3.1.4 South of Magunden Area Constraint.....	12
3.1.5 Windhub Area Constraint	14
3.1.6 Antelope – Vincent Area Constraint	16
3.1.7 SCE Northern Area Constraint Summary	17
3.2 North of Lugo Area.....	19
3.2.1 Kramer – Victor (South of Kramer) Area Constraint	19
3.2.2 Victor – Lugo (South of Victor) Area Constraint	21
3.2.3 Lugo – Calcite Area Constraint.....	23
3.2.4 Lugo AA Bank Area Constraint	25
3.2.5 North of Lugo Area Constraint Summary	27
3.3 SCE Metro Area	28
3.3.1 SCE Metro Area Constraint Summary.....	28
3.4 East of Pisgah Area.....	28
3.4.1 GLW Area Constraint.....	28
3.4.2 Sloan Canyon – Eldorado Area Constraint.....	30
3.4.3 Eldorado – McCullough Area Constraint	32
3.4.4 Lugo – Victorville Area Constraint	34
3.4.5 East of Pisgah Area Constraint Summary	37
3.5 Eastern Area.....	40
3.5.1 Colorado River 500/230 kV Area Constraint.....	40
3.5.2 DCRT Area Constraint	41
3.5.3 Devers-Red Bluff Area Constraint.....	43
3.5.4 Eagle Mountain Area Constraint.....	46
3.5.5 Mira Loma-Mesa Area Constraint	48

3.5.6 Red Bluff 500/230 kV Area Constraint53

3.5.7 Serrano-Alberhill-Valley Area Constraint55

3.5.8 SCE Eastern Area Constraint Summary59

4. TPD Allocation Results – SDGE Area62

4.1.1 San Luis Rey-San Onofre Area Constraint62

4.1.2 Encina-San Luis Rey Area Constraint64

4.1.3 Silvergate-Old Town Area Constraint67

4.1.4 Silvergate-Boulevard Area Constraint69

4.1.5 East of Miguel Area Constraint71

4.1.6 Internal San Diego Area (Melrose Tap-San Marcos) Constraint73

4.1.7 Internal San Diego Area (Doublet Tap-Friars) Constraint75

4.1.8 Sycamore Area Constraint77

4.1.9 SDGE Area Constraint Summary80

5. TPD Allocation Results – PGE Area82

5.1 North of Greater Bay Interconnection Area Constraints82

5.1.1 Collinsville-Tesla 500 kV Area Constraint82

5.2 Greater Bay Interconnection Area Constraints85

5.2.1 Bellota Area Constraint85

5.2.2 Bay Area Constraint86

5.2.3 Tesla-Westley 230kV Area Constraint88

5.2.4 Vaca – Contra Costa Area Constraint90

5.2.5 Lockeford 230 kV Area Constraint92

5.2.6 Banta 115 kV Area Constraint94

5.2.7 Tesla 115 kV Area Constraint96

5.3 Fresno Interconnection Area Constraints99

5.3.1 Gates 500/230 kV Transformer Area Constraint99

5.3.2 Gregg 230 kV Area Constraint103

5.3.3 Cottle 230 kV Area Constraint105

5.3.4 Mustang- Henrietta 230 kV Area Constraint107

5.4 Kern Interconnection Area Constraints110

5.4.1 Midway- Harlan 500 kV Area Constraint110

5.4.2 Gates-Arco-Midway 230 kV Area Constraint113

5.4.3 Bitterwater- Buena Vista 230kV kV Area Constraint*115

5.4.4 PG&E Area Constraint Summary117

1. Introduction

In accordance with the California Independent System Operator (CAISO) Generator Interconnection and Deliverability Allocation Procedures (GIDAP) Tariff Appendix DD, the CAISO performed Transmission Plan Deliverability (TPD) allocation for parked Queue Cluster 14 (QC14) projects requesting Full Capacity Deliverability Status (FCDS) or Partial Capacity Deliverability Status (PCDS). The study also allocated TPD to Energy Only (EO) projects that submitted affidavits through the TP Deliverability Allocation Process. These EO projects and parked QC14 projects are referred to as TPD candidates in this report.

Table 1.1 provides the summary of the 2025 TPD candidates.

Table 1.1: Summary of 2025 TPD Candidates

PTO Area	Parked QC14		Energy Only		Subscriber PTO	
	No. of Candidates	Total Seeking Interconnection Service Capacity (MW)	No. of Candidates	Total Seeking Interconnection Service Capacity (MW)	No. of Candidates	Total Seeking Interconnection Service Capacity (MW)
PG&E	34	8,988	13	839	0	0
SCE	33	8099	24	1717	0	0
GLW	4	1245	1	45	0	0
VEA	0	0	0	0	0	0
DCRT	3	1450	1	600	0	0
SDGE	10	2845	10	2567	0	0
SunZia	0	0	0	0	2	2951
Total	84	22627	49	5768	2	2951

2. Study Assumptions and Methodology

2.1 Representing Prior TPD Commitments

Consistent with ISO tariff Appendix DD section 8.9.1, the TPD is preserved for the following prior commitments before allocated to the TPD candidates:

- All generators that are operational and have achieved FCDS or PCDS
- All generators that are operational and waiting for Network Upgrades to achieve FCDS or PCDS
- Pre-QC5 projects that have executed PPAs with Load-Serving Entities and have GIAs that are in good standing
- Projects in QC5 through QC14 that have previously allocated TPD and meet TPD retention criteria in accordance with ISO tariff Appendix DD Section 8.9.3
- Potential Distributed Generator Deliverability (PDGD) identified in 2024-2025 DGD process

Generators with preserved TPD are kept in the deliverability assessment model. Generators in the interconnection queue through QC14 that do not meet any of the above and are not TPD candidates are deactivated (modeled offline with P_{MAX}=0) in the deliverability assessment model.

2.2 Representing TPD Candidates

TPD candidates that did not submit TPD allocation affidavit are not eligible for the allocation. TPD candidates that have submitted valid TPD allocation affidavit are placed in the proper allocation group. TPD candidates not belonging to any of the allocation group are not eligible for allocation.

The TPD allocation groups are –

- (A) Interconnection Customers that have executed power purchase agreements, and Interconnection Customers in the current Queue Cluster that are Load Serving Entities serving their own Load.
- (B) Interconnection Customers that are actively negotiating a power purchase agreement or on an active short list to receive a power purchase agreement.
- (C) Interconnection Customers that have achieved Commercial Operation for the capacity seeking TP Deliverability.
- (D) Interconnection Customers electing to be subject to Section 8.9.2.3.

Table 2.1: 2025 TP Deliverability Allocation Process Groups

Allocation Group	Project/Capacity Status	Commercial Status	Allocation Rank
A	Any project (active IR or achieved commercial operation)	Executed power purchase agreement requiring FCDS or interconnection customer is an LSE serving its own load	Allocated 1st
B	Any project (active IR or achieved commercial operation)	Shortlisted for power purchase agreement or actively negotiating a power purchase agreement	Allocated 2nd
C	Any project that achieved commercial operation	Commercial operation achieved	Allocated 3rd
D	Any active project that meets the allocation group D criteria	See criteria above	Allocated 4th

Each allocation TPD candidate will fall into one of the groups A through D with its TPD score. TPD is allocated by the order of the groups and the TPD score. EO generators could be allocated TPD under the condition that TP Deliverability is available from existing transmission facilities, from already planned upgrades in the CAISO Transmission Planning Process, or upgrades assigned to an interconnection project that has an executed GIA and currently has a TP Deliverability allocation.

2.3 Transmission

The following transmission upgrades are modeled in the TPD allocation study:

- ISO Approved Transmission upgrades as of January 30, 2025 were modeled in the TPD allocation study
- Network Upgrades identified in the generation interconnection studies and included in a executed Generation Interconnection Agreement
- Network Upgrades still needed in the latest generation interconnection study for the TPD candidates

The ISO approved transmission upgrades required before a generation project's allocated TPD received in this 2025 TPD allocation cycle can be converted to FCDS or PCDS are listed in the section describing each constraint. The upgrades required to mitigate every constraint that the generation project is behind are required to be in-service before that generation project's allocated TPD can be converted to FCDS or PCDS.

2.4 Deliverability Assessment

The deliverability assessment is performed for study areas where area deliverability constraints are identified. The generator and transmission setup from the above sections are used in the deliverability assessment. For each area deliverability constraint, the capacity of the TPD candidates is reduced one by one in the ascending order of the deliverability priority until the overloads are eliminated. The remaining generator capacity is the TPD allocation to the TPD candidates.

For study areas that do not have binding area constraints, typically the deliverability assessment is not performed. All eligible TPD candidates that do not contribute to area constraints receive 100% TPD allocation.

In areas where TPD candidates contribute to multiple overloaded facilities, typically only the worst overloaded facilities are reported.

Projects will be granted their requested FCDS only if they receive a TPD allocation. Furthermore, timing of obtaining the requested FCDS is dependent on the completion of DNU's identified in the Project's Phase II study and TPP upgrades identified in this report, which may be updated in any subsequent annual reassessment. Until such time that these DNU's and TPP upgrades are completed and placed in service, the Project may be granted Interim Deliverability Status based on annual system availability.

3. TPD Allocation Results – SCE Area

3.1 Northern Area

3.1.1 Pardee – Sylmar Area Constraint

The study identified the following overloads associated with the Pardee-Sylmar Area constraint

Table 3.1: Pardee Sylmar Area Constraint

Overloaded Facility	Contingency	Overload
24114 PARDEE 230 24155 VINCENT 230 2	PARDEE 230.0 to SYLMAR 230.0 Circuit 1 Line PARDEE 230.0 to SYLMAR 230.0 Circuit 2	102%

The Pardee- Sylmar Area constraint limits the deliverability of generators connected to the 230kV system shown below. The following figure illustrates the approximate electrical boundary of the 5% DFAX circle for the constraint.

Figure 3.1: Approximate electrical boundary of the projects within the 5% DFAX circle that contribute to the Pardee- Sylmar Area Constraint

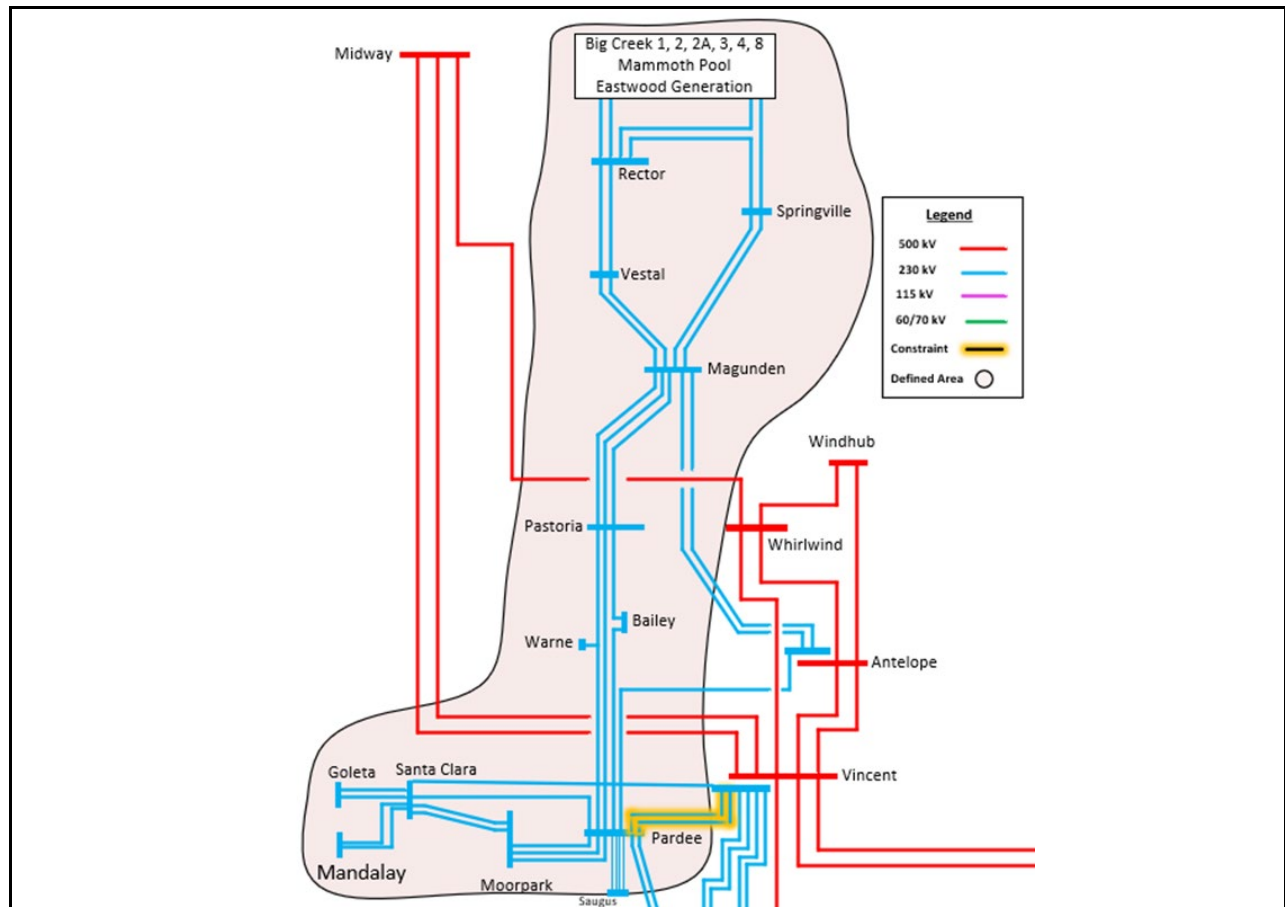

The following table shows the generation projects that are behind the constraint.

Table 3.2: Generation Projects Contributing to the Pardee- Sylmar Area Constraint

Queue	POI
297	Neenach- Bailey 66kV line
768	Antelope 230 kV
1335	Pastoria 230kV
1516	Vestal 230 kV
1619	Moorpark 230 kV
1783	Mandalay Switchyard 220kV
1789	Vestal 230 kV
1792	Vestal 230 kV
2059	Antelope 230 kV
2062	Antelope 230 kV
2064	Antelope 230 kV
2066	Moorpark 230 kV
2068	Rector 230 kV
2081	Rector 230 kV
2092	Moorpark 230 kV
WDT1187	Capitan 66 kV bus
WDT1384	Vestal 66 kV
WDT1454	Isla Vista 66 kV
WDT1519	Santa Clara - Gonzales 66 kV line
WDT1532	Wakefield 66 kV
WDT1539	Goleta 66kV
WDT1580	Bliss 66 kV
WDT1639	Vestal 66 kV
WDT1647	Moorpark 66 kV
WDT1649	North Oaks 66kV
WDT1650	Oakgrove – Riverway 66 kV Line
WDT1701	Wakefield 66 kV
WDT1710	Elizabeth Lake 66 kV
WDT1755	Antelope - Ritter Ranch #1 66 kV
WDT1766	Royal 66 kV
WDT1794	Tule 66kV
WDT1808	San Miguel 66 kV

TPD was allocated to the TPD candidates after first preserving for the non-operational prior commitment as described in section 2.1. There is sufficient TPD for all eligible candidates. The results are shown in the following table.

Table 3.3 TPD Allocation for Generation behind the Pardee- Sylmar Area Constraint

	Interconnection Service Capacity (MW)	Study Amount (MW)
Non-Operational Prior Commitment	3510	2891
Eligible TPD Candidate	1255	1039
TPD Allocated	1255	1039
Remaining TPD available	1336	1336
Total TPD (Non-Operational Prior Commitment + TPD Allocated + Remaining TPD available)	6101	5266

For Projects behind this constraint that are receiving an allocation in this TPD cycle, the following TPP upgrades are required in addition to the Reliability Network Upgrades and Local Delivery Network Upgrades identified for the Projects:

- Pardee – Sylmar 230kV Line Rating Increase Project

3.1.2 Moorpark - Pardee Area Constraint

The study identified a constraint on the Moorpark -Pardee 230kV transmission lines.

Table 3.4: Moorpark - Pardee Area Constraint

Overloaded Facility	Contingency	Overload
24099 MOORPARK 230 24114 PARDEE 230 2 or 3	MOORPARK to PARDEE 230 ck 1 line MOORPARK to PARDEE 230 ck 4	100%

The Moorpark - Pardee Area constraint limits the deliverability of generators connected to the Moorpark 230 kV system. The following figure illustrates the approximate electrical boundary of the 5% DFAX circle for the constraint.

Figure 3.2: Approximate electrical boundary of the projects within the 5% DFAX circle that contribute to the Moorpark - Pardee Area Constraint

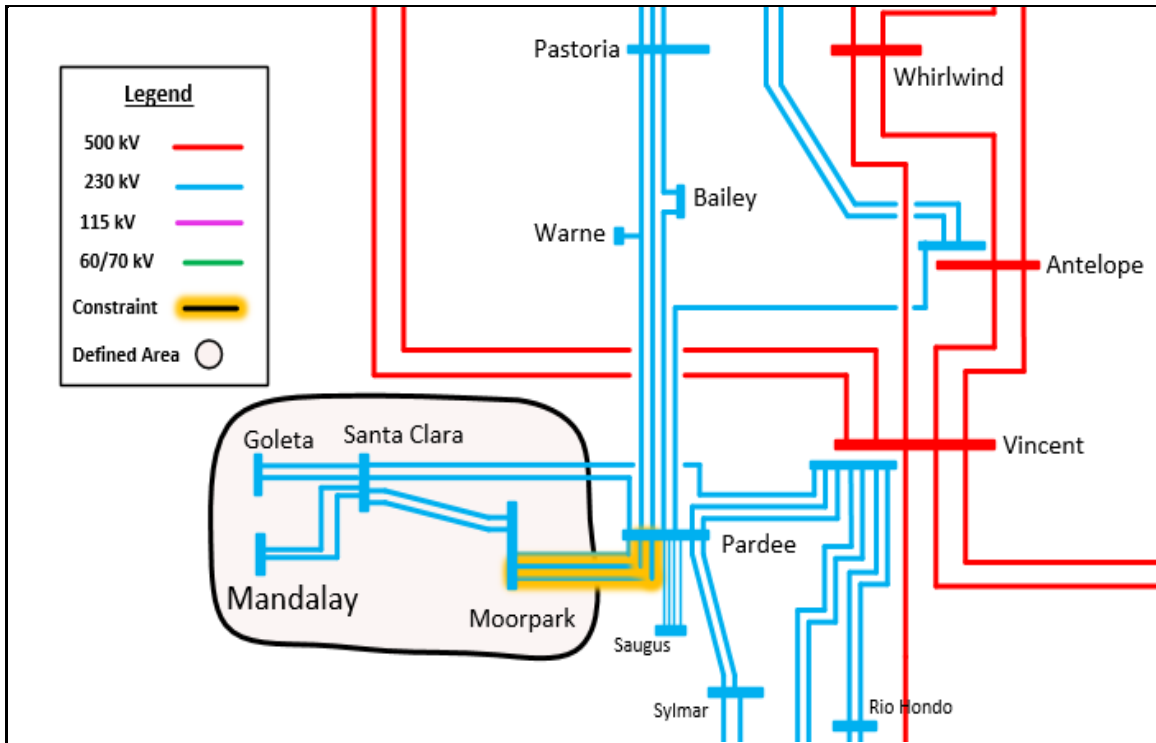

The following table shows the generation projects that are behind the constraint.

Table 3.5: Generation Projects Contributing to the Moorpark - Pardee Area Constraint

Queue	POI
1619	Moorpark 230 kV
1783	Mandalay 220 kV
2066	Moorpark 230 kV
2092	Moorpark 230 kV
WDT1187	Capitan 66 kV bus
WDT1454	Isla Vista 66 kV
WDT1519	Santa Clara - Gonzales 66 kV line
WDT1532	Wakefield 66 kV
WDT1539	Goleta 66 kV
WDT1647	Moorpark 66 kV
WDT1701	Wakefield 66 kV
WDT1766	Carpinteria 66 kV
WDT1808	San Miguel 66 kV

TPD was allocated to the TPD candidates after first preserving for the non-operational prior commitment as described in section 2.1. There isn't sufficient TPD for all eligible candidates. The results are shown in the following table.

Table 3.6 TPD Allocation for Generation behind the Moorpark - Pardee Area Constraint

	Interconnection Service Capacity (MW)	Study Amount (MW)
Non-Operational Prior Commitment	1947	1863
Eligible TPD Candidate	552	548
TPD Allocated	542	542
Remaining TPD available	0.0	0.0
Total TPD (Non-Operational Prior Commitment + TPD Allocated + Remaining TPD available)	2489	2405

For Projects behind this constraint that are receiving an allocation in this TPD cycle, the following TPP upgrades are required in addition to the Reliability Network Upgrades and Local Delivery Network Upgrades identified for the Projects:

- None

3.1.3 North of Magunden Area Constraint

The study identified a constraint on the North of Magunden 220kV transmission lines.

Table 3.7: North of Magunden Area Constraint

Overloaded Facility	Contingency	Overload
24304 BIG CRK4 230 24141 SPRINGVL 230 1 C	BIG CRK1 230.0 to RECTOR 230.0 Circuit 1 Line RECTOR	109%
24303 BIG CRK3 230 24235 RECTOR 230 2	230.0 to BIG CRK3 230.0 Circuit 1	114%

The North of Magunden Area constraint limits the deliverability of generators connected to the Big Creek 230 kV system. The following figure illustrates the approximate electrical boundary of the 5% DFAX circle for the constraint.

Figure 3.3: Approximate electrical boundary of the projects within the 5% DFAX circle that contribute to the North of Magunden Area Constraint

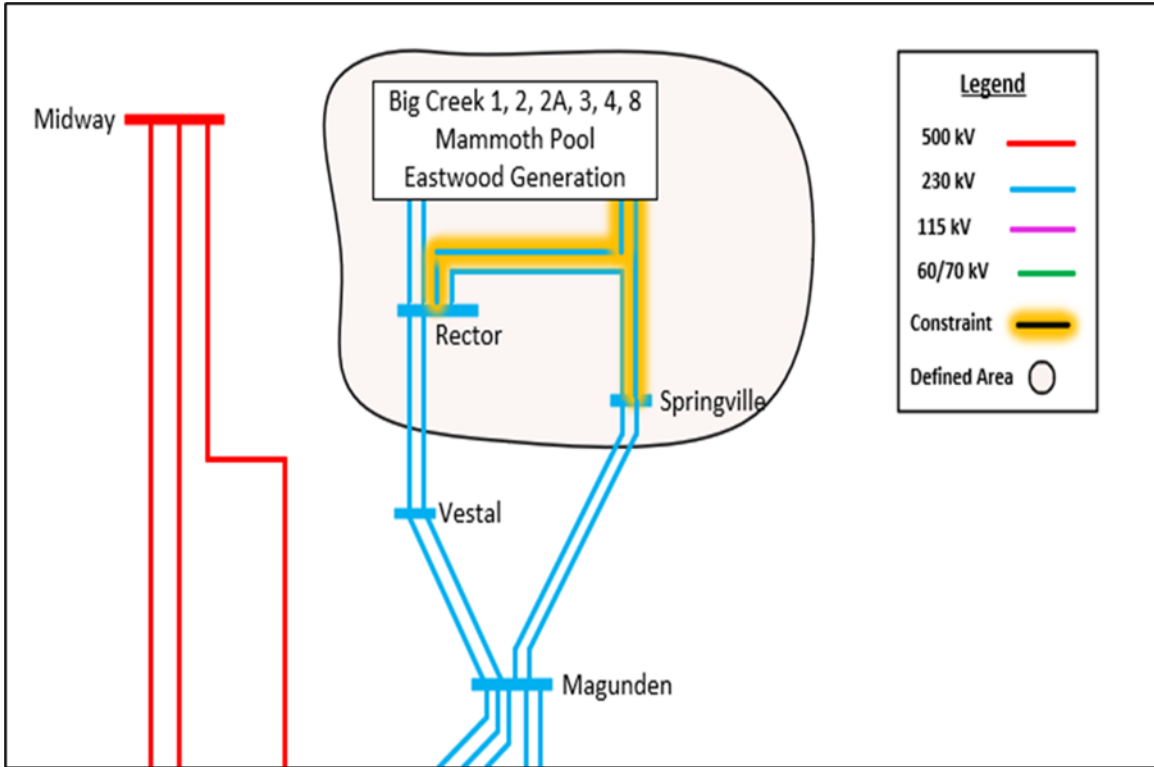

The following table shows the generation projects that are behind the constraint.

Table 3.8: Generation Projects Contributing to the North of Magunden Area Constraint

Queue	POI
2068	Rector 230 kV
2081	Rector 230 kV
WDT1650	Oakgrove – Riverway 66 kV Line
WDT1794	Tule 66 kV

TPD was allocated to the TPD candidates after first preserving for the non-operational prior commitment as described in section 2.1. There is sufficient TPD for all eligible candidates. The results are shown in the following table.

Table 3.9 TPD Allocation for Generation behind the North of Magunden Area Constraint

	Interconnection Service Capacity (MW)	Study Amount (MW)
Non-Operational Prior Commitment	81	57
Eligible TPD Candidate	356	354
TPD Allocated	356	354

Remaining TPD available	543	525
Total TPD (Non-Operational Prior Commitment + TPD Allocated + Remaining TPD available)	980	936

For Projects behind this constraint that are receiving an allocation in this TPD cycle, the following TPP upgrades are required in addition to the Reliability Network Upgrades and Local Delivery Network Upgrades identified for the Projects:

- None

3.1.4 South of Magunden Area Constraint

The study identified a constraint on the South of Magunden 220kV transmission lines.

Table 3.10: South of Magunden Area Constraint

Overloaded Facility	Contingency	Overload
24115 PASTORIA 230 24403 BAILEY 230 1	PARDEE 230.0 to PASTORIA 230.0 Circuit 1 <u>or</u> PARDEE- WarneTAP 230.0 to Pastoria 230.0 Circuit 1	105%

The South of Magunden Area constraint limits the deliverability of generators connected to the 230 kV system as shown. The following figure illustrates the approximate electrical boundary of the 5% DFAX circle for the constraint.

Figure 3.4: Approximate electrical boundary of the projects within the 5% DFAX circle that contribute to the South of Magunden Area Constraint

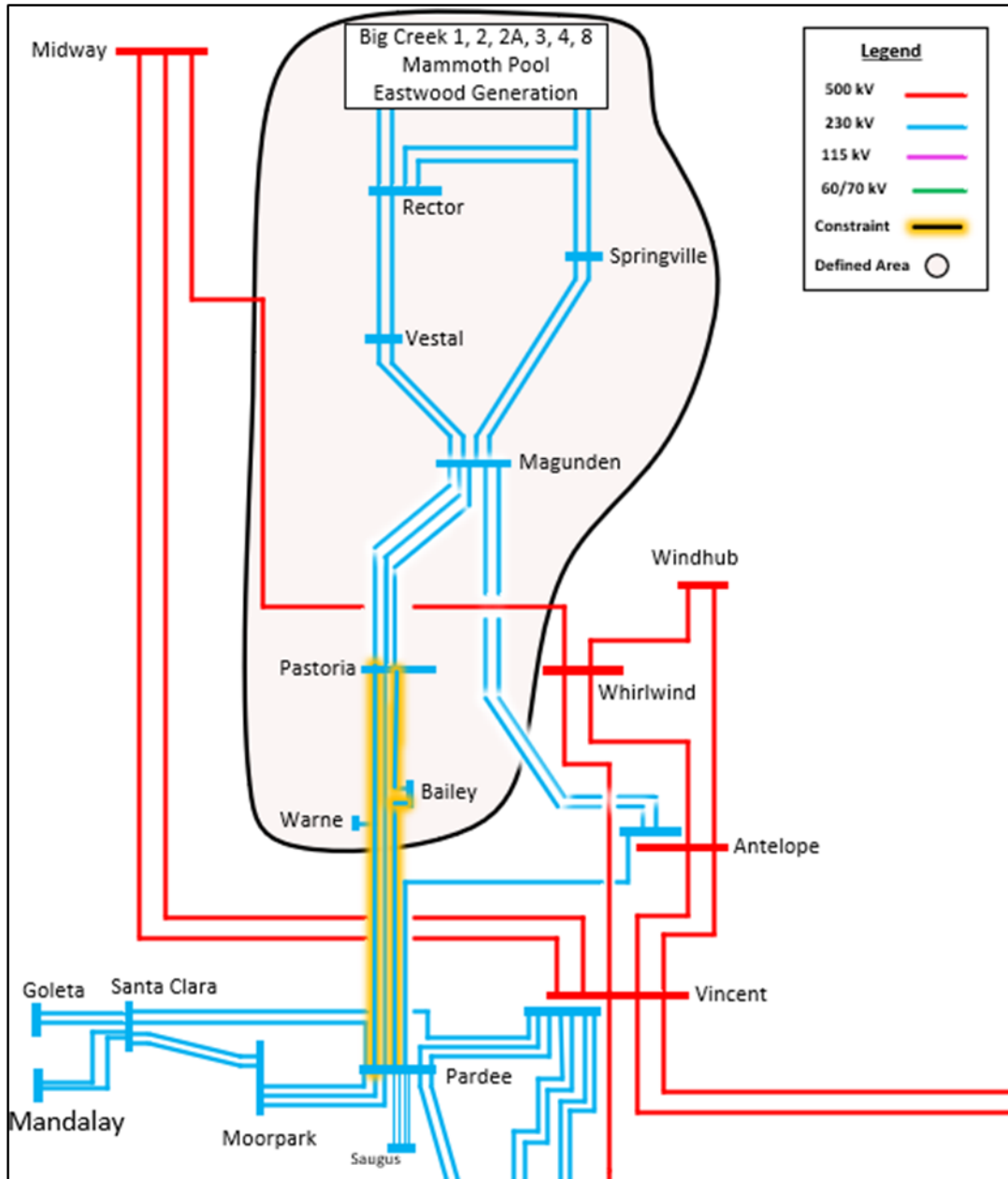

The following table shows the generation projects that are behind the constraint.

Table 3.11: Generation Projects Contributing to the South of Magunden Area Constraint

Queue	POI
1335	Pastoria 230 kV
1516	Vestal 230 kV
1789	Vestal 230 kV
1792	Vestal 230 kV

Queue	POI
2068	Rector 230 kV
2081	Rector 230 kV
WDT1384	Vestal 66 kV
WDT1639	Vestal 66 kV
WDT1650	Oakgrove – Riverway 66 kV Line
WDT1794	Tule 66 kV

TPD was allocated to the TPD candidates after first preserving for the non-operational prior commitment as described in section 2.1. There is sufficient TPD for all eligible candidates. The results are shown in the following table.

Table 3.12 TPD Allocation for Generation behind the South of Magunden Area Constraint

	Interconnection Service Capacity (MW)	Study Amount (MW)
Non-Operational Prior Commitment	1021	853
Eligible TPD Candidate	556	454
TPD Allocated	556	454
Remaining TPD available	889	880
Total TPD (Non-Operational Prior Commitment + TPD Allocated + Remaining TPD available)	2466	2187

For Projects behind this constraint that are receiving an allocation in this TPD cycle, the following TPP upgrades are required in addition to the Reliability Network Upgrades and Local Delivery Network Upgrades identified for the Projects:

- None

3.1.5 Windhub Area Constraint

The simultaneous or overlapping outage of the Antelope – Windhub 500kV and Whirlwind – Windhub 500kV lines without time for system adjustments is an extreme event for planning purposes. Under this extreme event there is potential voltage instability and widespread customer outages caused by the islanding of the Windhub substation and the consequential loss of generation. The total export from Windhub needs to be limited to maintain system security. This deliverability limit imposes a constraint for generators interconnecting to Windhub at all voltage levels and at Highwind 230kV substations.

Table 3.13: Windhub Area Constraint

Overloaded Facility	Contingency	Overload
Cascading outages	Antelope – Windhub 500kV line and Whirlwind – Windhub 500kV	N/A

The Windhub Area constraint limits the deliverability of generators connected to the Windhub 500 kV and 230 kV system. The following figure illustrates approximate electrical boundary of the 10% DFAX circle for the constraint.

Figure 3.5: Approximate electrical boundary of the projects within the 10% DFAX circle that contribute to the Windhub Area Constraint

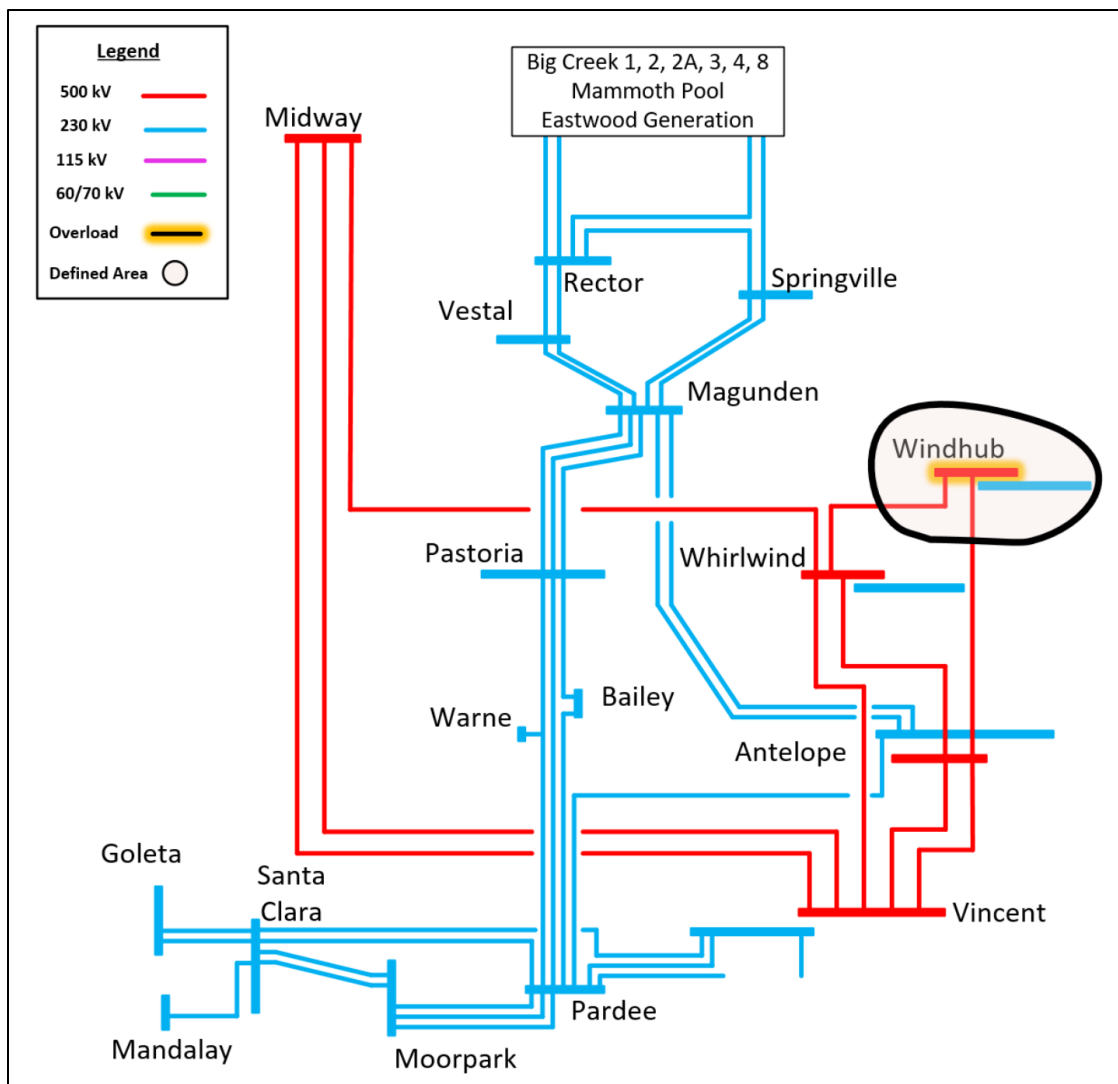

The following table shows the generation projects that are behind the constraint.

Table 3.14: Generation Projects Contributing to the Windhub Area Constraint

Queue	POI
96	Windhub 230 kV
1510	Windhub 230 kV
1518	Windhub 230 kV
1631	Windhub 230 kV
1632	Windhub 500 kV
1779	Windhub 230 kV

TPD was preserved for the 2448 MW non-operational prior commitment as described in section 2.1. There was no TPD available for eligible candidates. The results are shown in the following table.

Table 3.15 TPD Allocation for Generation behind the Windhub Area Constraint

	Interconnection Service Capacity (MW)	Study Amount (MW)
Non-Operational Prior Commitment	2448.0	1816.7
Eligible TPD Candidate	300.0	300.0
TPD Allocated	0.0	0.0
Remaining TPD available	0.0	0.0
Total TPD (Non-Operational Prior Commitment + TPD Allocated + Remaining TPD available)	2448.0	1816.7

For Projects behind this constraint that are receiving an allocation in this TPD cycle, the following TPP upgrades are required in addition to the Reliability Network Upgrades and Local Delivery Network Upgrades identified for the Projects:

- None

3.1.6 Antelope – Vincent Area Constraint

The Antelope Vincent Area Constraint shown in the Cluster 13 Phase I and earlier reports was based on the WECC’s common corridor 500 kV outage criterion. Due to a change in the WECC criteria, these outages are now considered extreme events, and are no longer required to meet the NERC performance criteria for a P7 outage. As a result this area constraint, based on a common corridor outage, was not binding.

3.1.7 SCE Northern Area Constraint Summary

The following table provides a summary showing all of the Deliverability Constraints described above and which non-operational generation projects are impacted by those constraints.

Table 3.16: SCE Northern Area Deliverability Constraint Mapping

Queue #	Pardee - Sylmar	Moorpark-Pardee	North of Magunden	South of Magunden	Windhub
96					X
297	X				
768	X				
1335	X			X	
1510					X
1516	X			X	
1518					X
1619	X	X			
1631					X
1632					X
1779					X
1783	X	X			
1789	X			X	
1792	X			X	
2059	X				
2062	X				
2064	X				
2066	X	X			
2068	X		X	X	
2081	X		X	X	
2092	X	X			
WDT1187	X	X			
WDT1384	X			X	
WDT1454	X	X			
WDT1519	X	X			
WDT1532	X	X			
WDT1539	X	X			
WDT1580	X				
WDT1639	X			X	
WDT1647	X	X			
WDT1649	X				

Queue #	Pardee - Sylmar	Moorpark-Pardee	North of Magunden	South of Magunden	Windhub
WDT1650	X		X	X	
WDT1701	X	X			
WDT1710	X				
WDT1755	X				
WDT1766	X	X			
WDT1794	X		X	X	
WDT1808	X	X			

3.2 North of Lugo Area

3.2.1 Kramer – Victor (South of Kramer) Area Constraint

The deliverability assessment identified normal condition overloads on Loop Station – Victor 230 kV in the SCE North of Lugo study area.

Table 3.17: Kramer-Victor area constraint in the SCE North of Lugo study area

Overloaded Facility	Contingency	Overload (%)
241306 LOOP 230 24601 VICTOR 230 1	Base Case	127.31
241306 LOOP 230 24601 VICTOR 230 1	P7_8_Line KRAMER - VICTOR 230.0 ck 3 Line KRAMER - VICTOR 230.0 ck 4	161.54
241306 LOOP 230 24601 VICTOR 230 1	P1.2_line_38_Line KRAMER 230.0 to VICTOR 230.0 Circuit 4	113.98
241306 LOOP 230 24601 VICTOR 230 1	P1.2_line_37_Line KRAMER 230.0 to VICTOR 230.0 Circuit 3	113.98
24701 KRAMER 230 24601 VICTOR 230 2	P7_8_Line KRAMER - VICTOR 230.0 ck 3 Line KRAMER - VICTOR 230.0 ck 4	112.18
24875 KRAMER 2i 12.0 24701 KRAMER 230 2	P7_1_Line KRAMER - COLWATER 230.0 ck 2 Line SANDLOT - KRAMER 230.0 ck 1	111.27
241306 LOOP 230 24601 VICTOR 230 1	P1.2_line_36_Line KRAMER 230.0 to VICTOR 230.0 Circuit 2	106.04
24701 KRAMER 230 241306 LOOP 230 1	P7_8_Line KRAMER - VICTOR 230.0 ck 3 Line KRAMER - VICTOR 230.0 ck 4	103.01
24702 KRAMER 115 24875 KRAMER 2i 12.0 2	P7_1_Line KRAMER - COLWATER 230.0 ck 2 Line SANDLOT - KRAMER 230.0 ck 1	100.75

This constraint limits deliverability of generators in the Inyokern-North of Victor transmission zone. The following figure illustrates approximate electrical boundary of the 5% DFAX circle for the constraint.

Figure 3.6: Approximate electrical boundary of the projects within the 5% DFAX circle that contribute to the Kramer-Victor area constraint

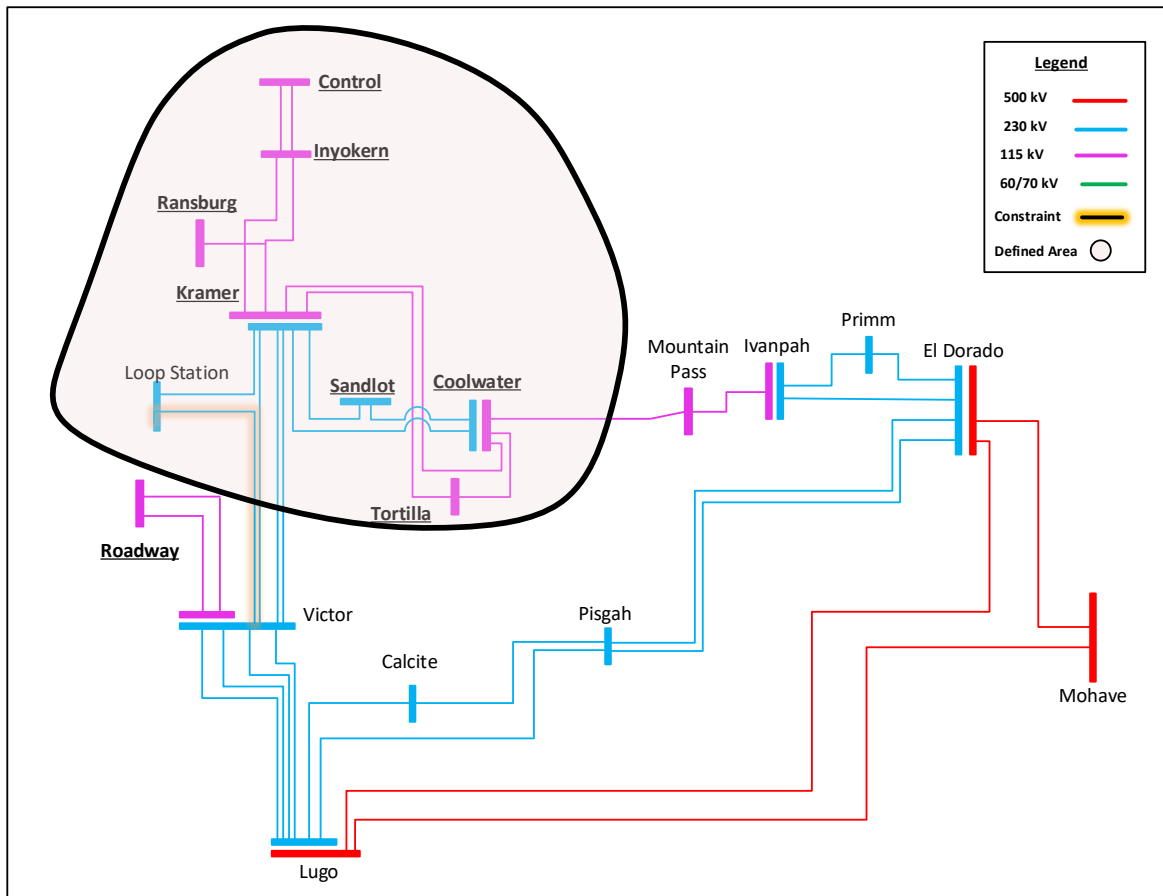

The following table shows the generation projects that are behind the Kramer-Victor area constraint.

Table 3.18: Generation Projects Contributing to the Kramer-Victor area constraint

CAISO / SCE #	Point of Interconnection
Q2096/TOT1064	Kramer-Victor 230kV Line
Q2101/TOT1091	Kramer 230kV Bus
Q1204/TOT773	Kramer 230kV Bus
Q1774/TOT981	Kramer-Coolwater 230kV Line
WDT1747	Inyokern 115/33kV Bus
WDT1748	Tortilla 115/33kV Bus
WDT1295	Edwards 115/33kV Bus

The 2025 TPD study identified a new Mira Loma-Mesa area constraint resulting from the removal of the Del Amo project. As a result of this constraint, no deliverability could be allocated to generators located in the North of Lugo area that were seeking deliverability in the 2025 TPD allocation cycle. The results are shown in the following table.

Table 3.19: TPD Allocation for Generation behind the Kramer-Victor area constraint

	Interconnection Service Capacity (MW)	Study Amount (MW)
Non-Operational Prior Commitment	489	323
Eligible TPD Candidate	633	615
TPD Allocated	0	0
Remaining TPD available	633	615
Total TPD (Non-Operational Prior Commitment + TPD Allocated + Remaining TPD available)	1122	938

3.2.2 Victor – Lugo (South of Victor) Area Constraint

The deliverability assessment identified emergency condition overloads on Victor - Lugo 230 kV No. 1 through No. 4 lines in the SCE North of Lugo study area.

Table 3.20: Victor-Lugo area constraint in the SCE North of Lugo study area

Overloaded Facility	Contingency	Overload (%)
Victor – Lugo 230 kV No. 1 & 2 or Victor – Lugo 230 kV No. 3 & 4	Victor – Lugo 230 kV No. 3 & 4 or Victor – Lugo 230 kV No. 1 & 2	134.69

This constraint limits deliverability of generators in the Victor - Lugo transmission zone. The following figure illustrates approximate electrical boundary of the 5% DFAX circle for the constraint.

Figure 3.7: Approximate electrical boundary of the projects within the 5% DFAX circle that contribute to the Victor to Lugo area constraint

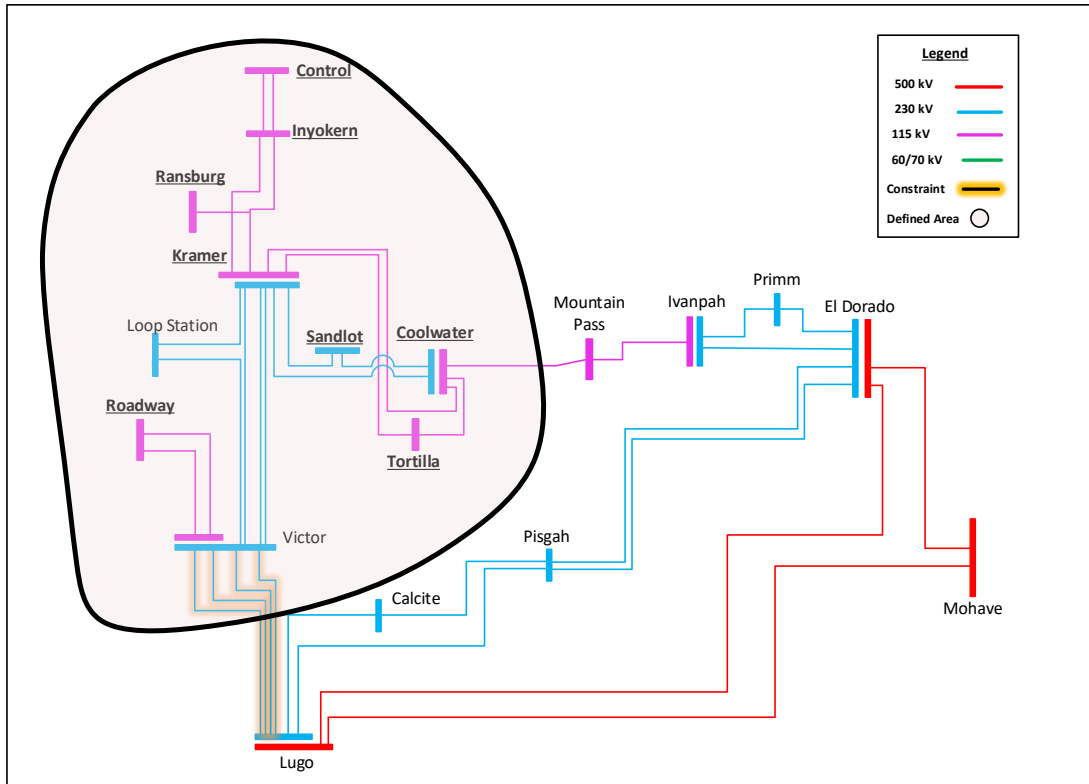

The following table shows the generation projects that are behind the Victor-Lugo area constraint.

Table 3.21: Generation Projects Contributing to the Victor-Lugo area constraint

CAISO / SCE #	Point of Interconnection
Q2104/TOT1109	Victor 230kV Bus
Q2096/TOT1064	Kramer-Victor 230kV Line
Q2101/TOT1091	Kramer 230kV Bus
Q1204/TOT773	Kramer 230kV Bus
Q1774/TOT981	Kramer-Coolwater 230kV Line
WDT1747	Inyokern 115/33kV Bus
WDT1748	Tortilla 115/33kV Bus
WDT1295	Edwards 115/33kV Bus
WDT1731	Victor 115kV Bus

The 2025 TPD study identified a new Mira Loma-Mesa area constraint resulting from the removal of the Del Amo project. As a result of this constraint, no deliverability could be allocated to generators located

in the North of Lugo area that were seeking deliverability in the 2025 TPD allocation cycle. The results are shown in the following table.

Table 3.22: TPD Allocation for Generation behind the Victor-Lugo area constraint

	Interconnection Service Capacity (MW)	Study Amount (MW)
Non-Operational Prior Commitment	491	324
Eligible TPD Candidate	1033	1015
TPD Allocated	0	0
Remaining TPD available	1033	1015
Total TPD (Non-Operational Prior Commitment + TPD Allocated + Remaining TPD available)	1524	1339

3.2.3 Lugo – Calcite Area Constraint

The deliverability assessment identified normal condition overloads on Lugo – Calcite 230 kV line in the SCE North of Lugo study area.

Table 3.23: Calcite-Lugo area constraint in the SCE North of Lugo study area

Overloaded Facility	Contingency	Overload (%)
25500 CALCITE 230 24085 LUGO 230 1	Base Case	127.21
25500 CALCITE 230 24085 LUGO 230 1	P7.1: NA: None:_NOL_line_101_Line ELDORDO 500.0 to LUGO 500.0 Circuit 1 & Line LUGO 500.0 to MOHAVE 5	145.56
25500 CALCITE 230 24085 LUGO 230 1	P1.2_line_141_Line LUGO 500.0 to VICTORVIL 500.0 Circuit 1	136.88
25500 CALCITE 230 24085 LUGO 230 1	P1.2_line_8_Line ELDORDO 500.0 to LUGO 500.0 Circuit 1	136.5
25500 CALCITE 230 24085 LUGO 230 1	P1.2_line_17_Line LUGO 500.0 to MOHAVE 500.0 Circuit 1	132.12
25500 CALCITE 230 24085 LUGO 230 1	P1.2: : 0:L_P1_105_MOHAVE 500.0 to ELDORDO 500.0 Circuit 1	131.68
25500 CALCITE 230 24085 LUGO 230 1	P7_1_Line KRAMER - COLWATER 230.0 ck 2 Line SANDLOT - KRAMER 230.0 ck 1	127.97

Overloaded Facility		Contingency	Overload (%)
25500 CALCITE	230	P1.2_line_112_Line CALCITE	103.07
24219 PISGAH	230 1	230.0 to LUGO 230.0 Circuit	
		1	

This constraint limits deliverability of generators behind the Calcite - Lugo Area Constraint. The following figure illustrates approximate electrical boundary of the 5% DFAX circle for the constraint.

Figure 3.8: Approximate electrical boundary of the projects within the 5% DFAX circle that contribute to the Calcite - Lugo area constraint

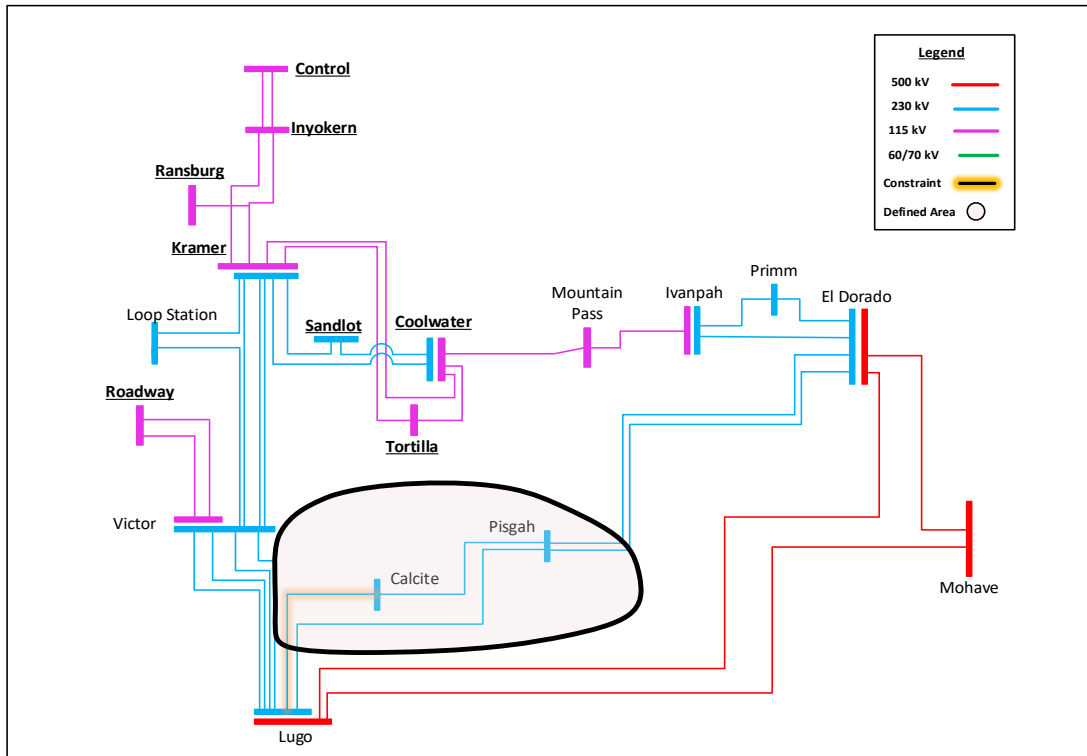

The following table shows the generation projects that are behind the Calcite – Lugo area constraint.

Table 3.24: Generation Projects Contributing to the Calcite - Lugo area constraint

CAISO / SCE #	Point of Interconnection
Q2097/TOT1046	Calcite 230kV Bus
Q2103/TOT1106	Pisgah 230kV Bus
Q1207/TOT761	Calcite 230kV Bus

The 2025 TPD study identified a new Mira Loma-Mesa area constraint resulting from the removal of the Del Amo project. As a result of this constraint, no deliverability could be allocated to generators located

in the North of Lugo area that were seeking deliverability in the 2025 TPD allocation cycle. The results are shown in the following table.

Table 3.25: TPD Allocation for Generation behind the Calcite - Lugo area constraint

	Interconnection Service Capacity (MW)	Study Amount (MW)
Non-Operational Prior Commitment	814	541
Eligible TPD Candidate	60	60
TPD Allocated	0	0
Remaining TPD available	0	0
Total TPD (Non-Operational Prior Commitment + TPD Allocated + Remaining TPD available)	814	541

3.2.4 Lugo AA Bank Area Constraint

The deliverability assessment identified emergency condition overloads on Lugo 500/230 kV AA banks #1 , #2, and #3 in the SCE North of Lugo study area.

Table 3.26: Lugo AA Bank constraint in the SCE North of Lugo study area

Overloaded Facility	Contingency	Overload (%)
Lugo 500/230kV AA Banks & #2 & #3, or #1 & #3, or #1 & #2	Lugo 500/230 kV AA Bank #1 or #2 or #3	118.28

This constraint limits deliverability of generators behind the Lugo AA Bank area constraint. The following figure illustrates approximate electrical boundary of the 5% DFAX circle for the constraint.

Figure 3.9: Approximate electrical boundary of the projects within the 5% DFAX circle that contribute to the Lugo AA Bank constraint

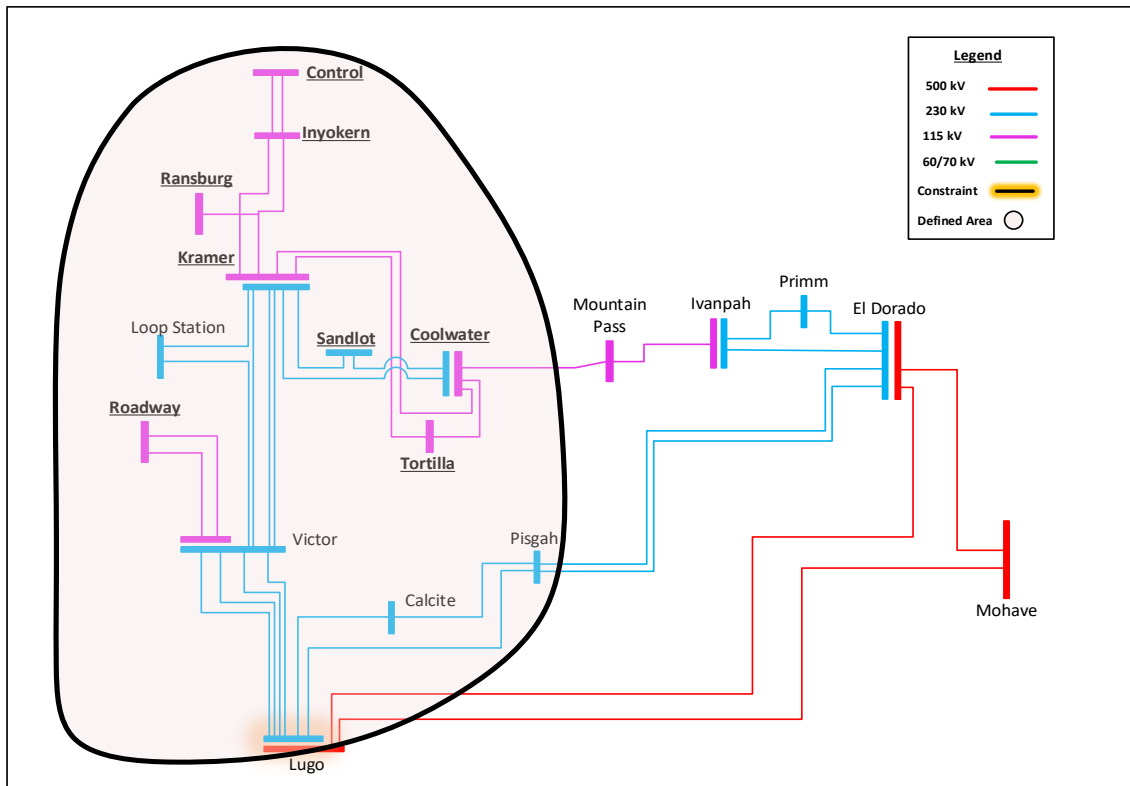

The following table shows the generation projects that are behind the Lugo AA Bank constraint.

Table 3.27: Generation Projects Contributing to the Lugo AA Bank constraint

CAISO / SCE #	Point of Interconnection
Q2104/TOT1109	Victor 230kV Bus
Q2097/TOT1046	Calcite 230kV Bus
Q2096/TOT1064	Kramer-Victor 230kV Line
Q2101/TOT1091	Kramer 230kV Bus
Q2103/TOT1106	Pisgah 230kV Bus
Q1207/TOT761	Calcite 230kV Bus
Q1204/TOT773	Kramer 230kV Bus
Q1774/TOT981	Kramer-Coolwater 230kV Bus
WDT1747	Inyokern 115/33kV Bus
WDT1748	Tortilla 115/33kV Bus
WDT1295	Edwards 115/33kV Bus
WDT1731	Victor 115/33kV Bus

The 2025 TPD study identified a new Mira Loma-Mesa area constraint resulting from the removal of the Del Amo project. As a result of this constraint, no deliverability could be allocated to generators located in the North of Lugo area that were seeking deliverability in the 2025 TPD allocation cycle. The results are shown in the following table.

Table 3.28: TPD Allocation for Generation behind the Lugo AA Bank constraint

	Interconnection Service Capacity (MW)	Study Amount (MW)
Non-Operational Prior Commitment	1304	865
Eligible TPD Candidate	1093	1075
TPD Allocated	0	0
Remaining TPD available	1093	1075
Total TPD (Non-Operational Prior Commitment + TPD Allocated + Remaining TPD available)	2397	1940

3.2.5 North of Lugo Area Constraint Summary

The following table provides a summary showing all of the Deliverability Constraints described above and which non-operational generation projects are impacted by those constraints.

Table 3.4-29: North of Lugo Area Deliverability Constraint Mapping

CAISO / SCE #	Point of Interconnection	Kramer-Victor (South Of Kramer)	Victor-Lugo (South Of Victor)	Calcite - Lugo	Lugo Bank	Mira Loma-Mesa
Q2104/TOT1109	Victor 230kV Bus		X		X	X
Q2097/TOT1046	Calcite 230kV Bus			X	X	X
Q2096/TOT1064	Kramer-Victor 230kV Line	X	X		X	X
Q2101/TOT1091	Kramer 230kV Bus	X	X		X	X
Q2103/TOT1106	Pisgah 230kV Bus			X	X	X
Q1207/TOT761	Calcite 230kV Bus			X	X	X
Q1204/TOT773	Kramer 230kV Bus	X	X		X	X
Q1774/TOT981	Kramer-Coolwater 230kV Bus	X	X		X	X
WDT1747	Inyokern 115/33kV Bus	X	X		X	X

CAISO / SCE #	Point of Interconnection	Kramer-Victor (South of Kramer)	Victor-Lugo (South of Victor)	Calcite - Lugo	Lugo Bank	Mira Loma-Mesa
WDT1748	Tortilla 115/33kV Bus	X	X		X	X
WDT1295	Edwards 115/33kV Bus	X	X		X	X
WDT1731	Victor 115/33kV Bus		X		X	X

3.3 SCE Metro Area

The deliverability assessment study did not identify any transmission deliverability constraints in the SCE Metro study area. However, the Mira Loma-Mesa constraint (SCE Eastern area) does affect some Metro area generation. There were no network upgrades approved in the TPP required for the TPD allocations in the cycle, in this area.

3.3.1 SCE Metro Area Constraint Summary

The following table provides a summary showing all of the Deliverability Constraints described above and which non-operational generation projects are impacted by those constraints.

Table 3.5-22: SCE Metro Area Deliverability Constraint Mapping

Queue No.	Mira Loma-Mesa
WDT1761	x

3.4 East of Pisgah Area

3.4.1 GLW Area Constraint

The deliverability assessment identified the Category P7 and P1 contingency overloads on transmission lines and transformers shown in Table 3.4-1.

Table 3.4-1: GLW Area Constraint in East of Pisgah study area

Overloaded Facility	Contingency	Overload
Gamebird 230/138kV Transformer	Trout Canyon – Sloan Canyon 500kV Nos. 1&2 lines	132.26
Sandy – Amargosa 138kV line	Trout Canyon – Sloan Canyon 500kV Nos. 1&2 lines	123.24
Gamebird – Sandy 138kV line	Trout Canyon – Sloan Canyon 500kV Nos. 1&2 lines	107.55
IS Tap – Northwest 138kV Line	Trout Canyon – Sloan Canyon 500kV Nos. 1&2 lines	107.09
Innovation 138kV PST	Northwest – Desert View 230kV Nos. 1&2 lines	103.75

The GLW area constraint results have considered the GLW existing and planned Sloan Canyon RAS, Innovation RAS and Gamebird RAS. The most limiting element is the overload on Gamebird 230/138 kV transformer following Category P7 contingency of Trout Canyon - Sloan Canyon 500 kV Nos. 1&2 lines with Sloan Canyon RAS. The Sloan Canyon RAS has been fully allocated. None of the projects seeking TPD behind this constraint received any TPD in this cycle.

The following figure illustrates approximate electrical boundary of the 5% DFAX circle for the constraint.

Figure 3.4-1: Approximate electrical boundary of the projects within the 5% DFAX circle that contribute to the GLW Area Constraint

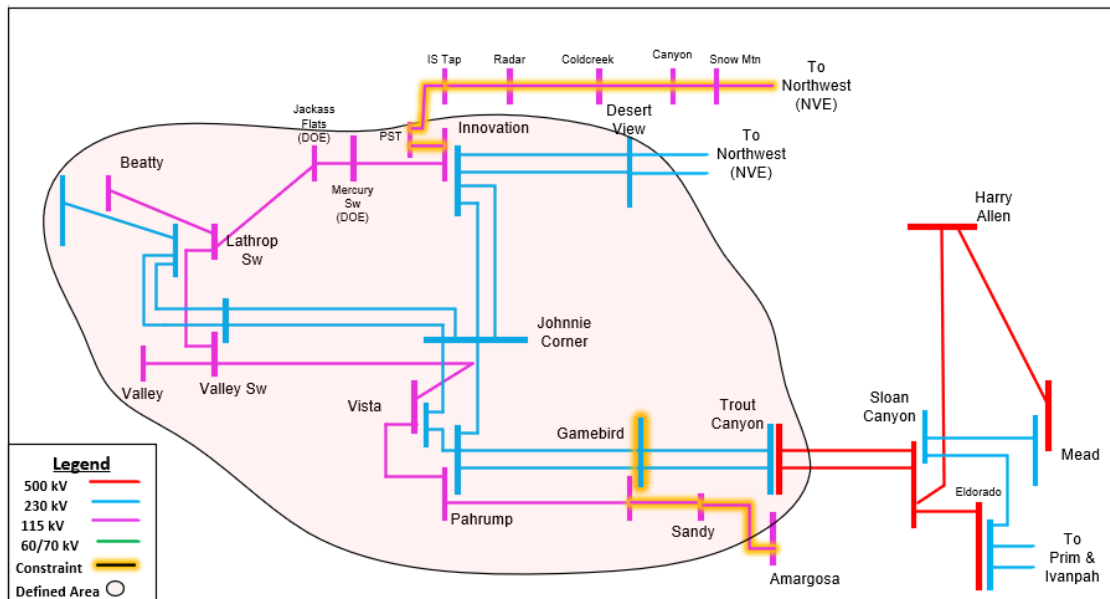

The following table lists non-operational generation projects that are behind the constraint.

Table 3.4-2: Generation Projects behind GLW Area Constraint

Queue	POI/POD
1649	Innovation Substation 230kV
1650	Trout Canyon Substation 230kV

Queue	POI/POD
1654	Trout Canyon Substation 230kV
1655	Trout Canyon Substation 230kV
1798	Trout Canyon Substation 230kV
1799	Trout Canyon Substation 230kV
1800	Trout Canyon Substation 230kV
1801	Gamebird Substation 230kV
2144	Valley Switch 230kV
2145	Vista Substation 230kV
2147	Innovation – Desert View 230kV Line
2148	Trout Canyon Substation 230kV
2149	Trout Canyon Substation 230kV
2150	Trout Canyon Substation 230kV

TPD was allocated to the TPD candidates after first preserving for the non-operational prior commitment as described in section 2.1. The results are shown in the following table.

Table 3.4-3: TPD Allocation for Generation behind the GLW Area Constraint

	Interconnection Service Capacity (MW)	Study Amount (MW)
Non-Operational Prior Commitment	3,050	2,776
Eligible TPD Candidate	1,390	930
TPD Allocated	0 ¹	0
Remaining TPD available	77 ²	77
Total TPD (Non-Operational Prior Commitment + TPD Allocated + Remaining TPD available)	3,127	2,853

3.4.2 Sloan Canyon – Eldorado Area Constraint

The deliverability assessment identified base case and contingency overloads on Sloan Canyon – Eldorado 500 kV Line as summarized in Table 3.4-4.

¹ The projects that passed/partially passed this constraint would be curtailed for other constraints in EOP area, so no TPD was able to be allocated to any seeking projects in EOP area.

² The remaining TPD refers to the TPD that was able to allocate to the seeking projects in this cycle. However, since the projects were behind other constraints and that resulted in remaining TPD for the GLW constraint.

Table 3.4-4: Sloan Canyon – Eldorado Area Constraint in East of Pisgah study area

Overloaded Facility	Contingency	Overload
Sloan Canyon – Eldorado 500kV Line	Base Case	125.15
	Harry Allen – Mead 500kV line	108.74
	Innovation – Johnnie Corner 230kV Nos. 1&2	103.18
	Northwest – Desert View 230kV Nos. 1&2	103.11

The following figure illustrates approximate electrical boundary of the 10% DFAX circle for the constraint.

Figure 3.4-2: Approximate electrical boundary of the projects within the 10% DFAX circle that contribute to the Sloan Canyon – Eldorado Area Constraint

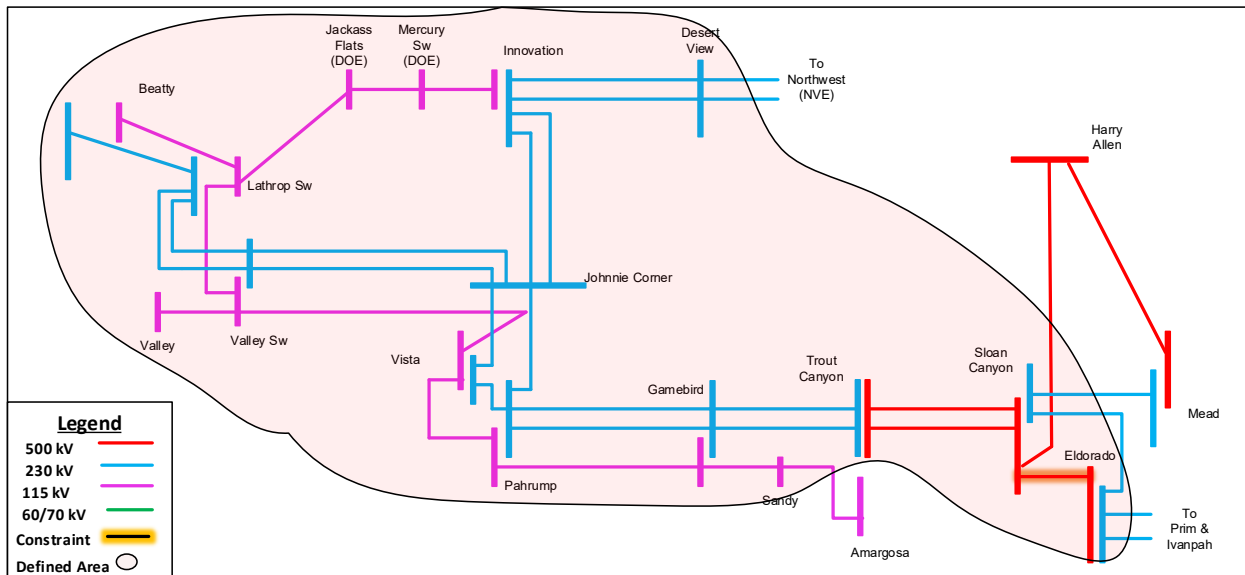

The following table lists non-operational generation projects that are behind the constraint.

Table 3.4-5: Generation Projects behind Sloan Canyon – Eldorado Area Constraint

Queue	POI/POD
1347	Sloan Canyon Substation 230kV
1649	Innovation Substation 230kV
1650	Trout Canyon Substation 230kV
1654	Trout Canyon Substation 230kV
1655	Trout Canyon Substation 230kV
1796	SCE owned Eldorado Bus 230 kV
1798	Trout Canyon Substation 230kV
1799	Trout Canyon Substation 230kV
1800	Trout Canyon Substation 230kV

Queue	POI/POD
1801	Gamebird Substation 230kV
2141	SCE owned Eldorado Bus 230 kV
2144	Valley Switch 230kV
2145	Vista Substation 230kV
2147	Innovation – Desert View 230kV Line
2148	Trout Canyon Substation 230kV
2149	Trout Canyon Substation 230kV
2150	Trout Canyon Substation 230kV

TPD was allocated to the TPD candidates after first preserving for the non-operational prior commitment as described in section 2.1. The results are shown in the following table.

Table 3.4-6: TPD Allocation for Generation behind the Sloan Canyon – Eldorado Area Constraint

	Interconnection Service Capacity (MW)	Study Amount (MW)
Non-Operational Prior Commitment	3,427	3,153
Eligible TPD Candidate	1,640	1,180
TPD Allocated	0	0
Remaining TPD available	0	0
Total TPD (Non-Operational Prior Commitment + TPD Allocated + Remaining TPD available)	3,427	3,153

3.4.3 Eldorado – McCullough Area Constraint

The deliverability assessment identified contingency overloads on Eldorado – McCullough 500 kV line as listed below.

Table 3.4-7: Eldorado – McCullough Area Constraint in East of Pisgah study area

Overloaded Facility	Contingency	Overload
Eldorado – McCullough 500kV Line	Eldorado – Lugo 500kV line	132.92
	Lugo – Mohave 500kV line	136.24

The following figure illustrates approximate electrical boundary of the 10% DFAX circle for the constraint.

Figure 3.4-3: Approximate electrical boundary of the projects within the 10% DFAX circle that contribute to the Eldorado – McCullough Area Constraint

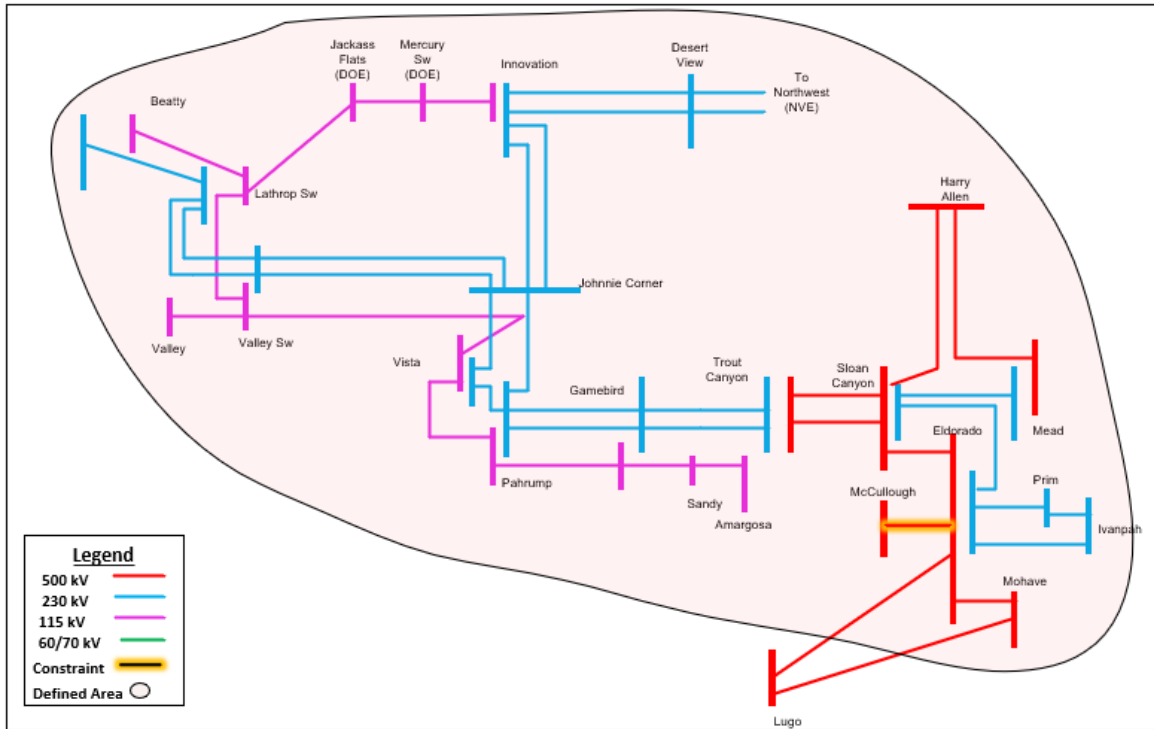

The following table lists non-operational generation projects that are behind the constraint.

Table 3.4-8: Generation Projects behind Eldorado – McCullough Area Constraint

Queue	POI/POD
1347	Sloan Canyon Substation 230kV
1522	Mohave 500kV
1647	Mohave 500kV
1649	Innovation Substation 230kV
1650	Trout Canyon Substation 230kV
1654	Trout Canyon Substation 230kV
1655	Trout Canyon Substation 230kV
1795	Mohave 500kV
1796	SCE owned Eldorado Bus 230 kV
1798	Trout Canyon Substation 230kV
1799	Trout Canyon Substation 230kV
1800	Trout Canyon Substation 230kV
1801	Gamebird Substation 230kV
2140	Mohave 500kV
2141	SCE owned Eldorado Bus 230 kV
2144	Valley Switch 230kV

Queue	POI/POD
2145	Vista Substation 230kV
2147	Innovation – Desert View 230kV Line
2148	Trout Canyon Substation 230kV
2149	Trout Canyon Substation 230kV
2150	Trout Canyon Substation 230kV

TPD was allocated to the TPD candidates after first preserving for the non-operational prior commitment as described in section 2.1. The results are shown in the following table.

Table 3.4-9: TPD Allocation for Generation behind the Eldorado - McCullough Constraint

	Interconnection Service Capacity (MW)	Study Amount (MW)
Non-Operational Prior Commitment	5,047	4,773
Eligible TPD Candidate	1,640	1,180
TPD Allocated	0	0
Remaining TPD available	0	0
Total TPD (Non-Operational Prior Commitment + TPD Allocated + Remaining TPD available)	5,047	4,773

3.4.4 Lugo – Victorville Area Constraint

The deliverability assessment identified contingency overload on Lugo – Victorville 500 kV line as listed below. The existing Lugo – Victorville RAS was modeled in the study and the RAS has been fully allocated.

Table 3.4-10: Lugo – Victorville Area Constraint in East of Pisgah study area

Overloaded Facility	Contingency	Overload
Lugo – Victorville 500kV Line	Eldorado – Lugo 500kV line	108.31

This constraint could potentially limit deliverability of generators in East of Pisgah, SDG&E, SCE Eastern, Northern and Metro study areas. The following figure illustrates approximate electrical boundary of the 10% DFAX circle for the constraint.

Figure 3.4-4: Approximate electrical boundary of the projects within the 10% DFAX circle that contribute to the Lugo-Victorville Area Constraint

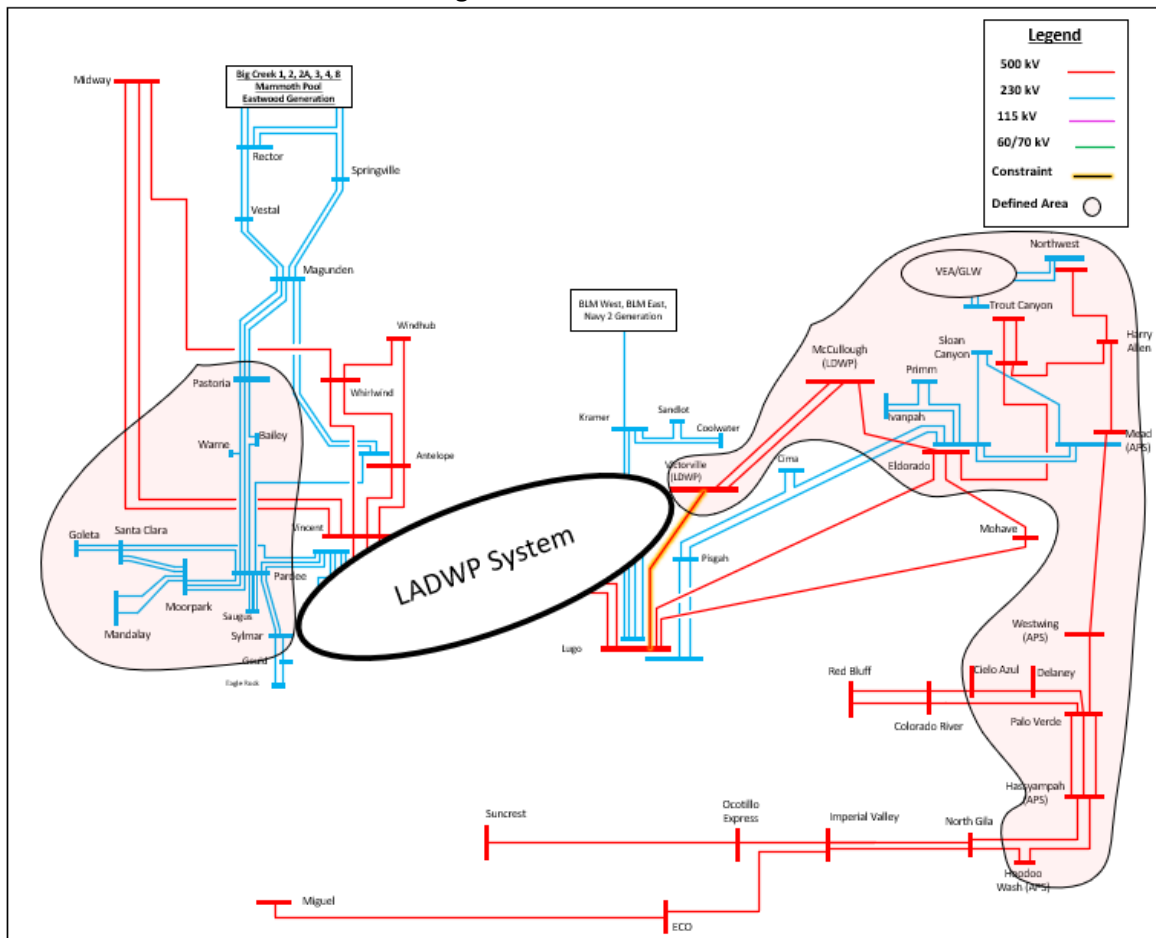

The following table lists non-operational generation projects that are behind the constraint.

Table 3.4-11: Generation Projects behind Lugo – Victorville Area Constraint

Queue	POI/POD
1335	Pastoria Substation 230 kV
1347	Sloan Canyon Substation 230 kV
1529	Delaney-Colorado River 500 kV line
1534	Hassayampa Common Bus 500 kV
1649	Innovation Substation 230 kV
1650	Trout Canyon Substation 230 kV
1654	Trout Canyon Substation 230 kV
1655	Trout Canyon Substation 230 kV
1678	Delaney Substation 500 kV
1783	Mandalay Switchyard 220 kV

Queue	POI/POD
1796	Eldorado Substation 230 kV
1798	Trout Canyon Substation 230 kV
1799	Trout Canyon Substation 230 kV
1800	Trout Canyon Substation 230 kV
1801	Gamebird Substation 230 kV
1812	Hoodoo Wash Switchyard 500 kV
1818	Hassayampa Common Bus 500 kV
2022	Cielo Azul Substation 500 kV
2025	Colorado River-Delaney 500 kV line
2027	Delaney Substation 500 kV
2029	Delaney Substation 500 kV
2066	Moorpark Substation 230 kV
2092	Moorpark Substation 230 kV
2141	SCE portion of Eldorado Substation 230 kV
2144	Beatty Substation 230kV
2145	Vista Substation 230kV
2147	Innovation – Desert View 230kV Line
2148	Trout Canyon Substation 230kV
2149	Trout Canyon Substation 230kV
2150	Trout Canyon Substation 500kV
2154	Hoodoo Wash Switchyard 500 kV
	SunZia Wind
WDT 1187	Capitan 66 kV
WDT 1454	Isla Vista 66 kV
WDT 1532	Wakefield 66 kV
WDT 1647	Moorpark 66 kV
WDT 1701	Wakefield 66 kV
WDT 1710	Elizabeth Lake 66 kV
WDT 1808	San Miguel 66 kV

TPD was allocated to the TPD candidates after first preserving for the non-operational prior commitment as described in section 2.1. The results are shown in the following table.

Table 3.4-12: TPD Allocation for Generation behind the Lugo – Victorville Area Constraint

	Interconnection Service Capacity (MW)	Study Amount (MW)
Non-Operational Prior Commitment	6,126	5,475
Eligible TPD Candidate	7,216	5,664
TPD Allocated	3,422	2,448
Remaining TPD available	2,261	1,886
Total TPD (Non-Operational Prior Commitment + TPD Allocated + Remaining TPD available)	11,809	9,809

For Projects behind this constraint that are receiving an allocation in this TPD cycle, the following TPP upgrades are required in addition to the Reliability Network Upgrades identified for the Projects:

- Southern area reinforcement project

3.4.5 East of Pisgah Area Constraint Summary

The following table provides a summary showing all of the Deliverability Constraints described above and which non-operational generation projects are impacted by those constraints.

Table 3.4-13: East of Pisgah Area Deliverability Constraint Mapping

Queue	GLW Area Constraint	Sloan Canyon – Eldorado 500kV Constraint	Eldorado – McCullough 500kV Constraint	Lugo – Victorville 500kV Constraint	Mira Loma – Mesa 500kV Constraint
1347		x	x	x	x
1522			x		x
1647			x		x
1649	x	x	x	x	x
1650	x	x	x	x	x
1654	x	x	x	x	x
1655	x	x	x	x	x
1795			x	x	x
1796		x	x	x	x
1798	x	x	x	x	x
1799	x	x	x	x	x
1800	x	x	x	x	x
1801	x	x	x	x	x
2140			x		x
2141		x	x	x	x
2144	x	x	x	x	x
2145	x	x	x	x	x
2147	x	x	x	x	x
2148	x	x	x	x	x
2149	x	x	x	x	x
2150	x	x	x	x	x

Queue	POI/POD
1347	Sloan Canyon Substation 230kV
1522	Mohave 500kV
1647	Mohave 500kV
1649	Innovation Substation 230kV
1650	Trout Canyon Substation 230kV
1654	Trout Canyon Substation 230kV
1655	Trout Canyon Substation 230kV
1795	Mohave 500kV
1796	SCE owned Eldorado Bus 230 kV
1798	Trout Canyon Substation 230kV
1799	Trout Canyon Substation 230kV
1800	Trout Canyon Substation 230kV
1801	Gamebird Substation 230kV
2140	Mohave 500kV
2141	SCE owned Eldorado Bus 230 kV
2144	Valley Switch 230kV
2145	Vista Substation 230kV
2147	Innovation – Desert View 230kV Line
2148	Trout Canyon Substation 230kV
2149	Trout Canyon Substation 230kV
2150	Trout Canyon Substation 230kV

3.5 Eastern Area

3.5.1 Colorado River 500/230 kV Area Constraint

The deliverability assessment identified the following overloads.

Table 3.5-1: Colorado River 500/230 kV Constraint

Overloaded Facility	Contingency	Overload
Colorado River 500/230 kV Transformer No.1	Colorado River 500/230 kV Transformer No.2	183%
Colorado River 500/230 kV Transformer No.2	Colorado River 500/230 kV Transformer No.1	183%
Colorado River 500/230 kV Transformer No.1	Base Case	110%
Colorado River 500/230 kV Transformer No.2	Base Case	107%

The following figure illustrates the approximate electrical boundary of the 5% DFAX circle for the constraint.

Figure 3.5-1: Approximate electrical boundary of the projects within the 5% DFAX circle that contribute to the Colorado River 500/230 kV Constraint

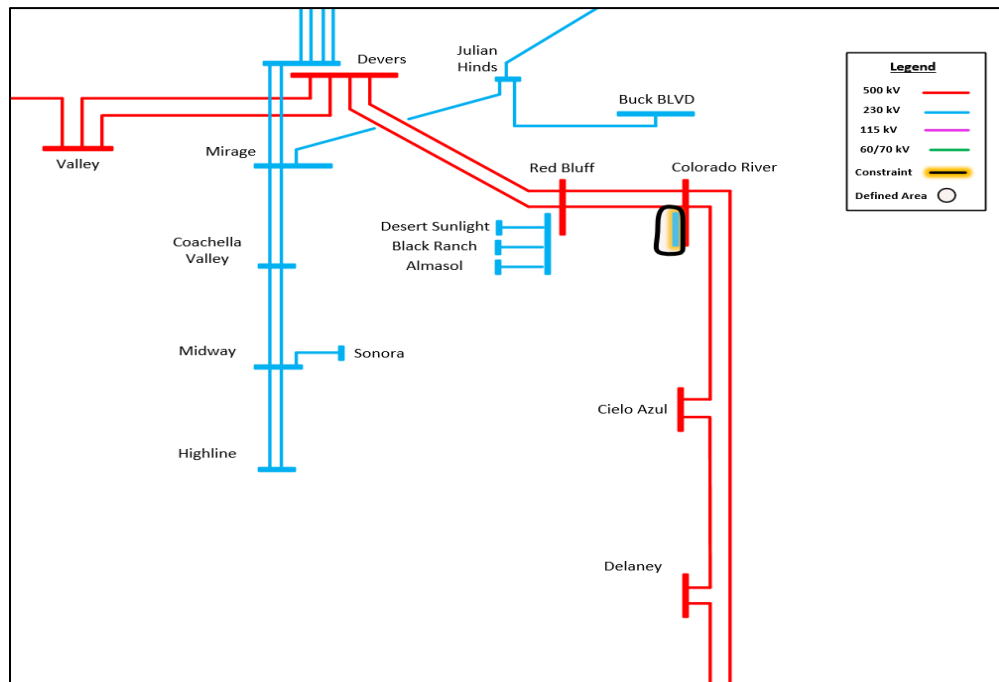

The following table shows the generation projects that are behind the constraint.

Table 3.5-2: Generation Projects Contributing to the Colorado River 500/230 kV Constraint

Queue	POI
1761	Colorado River Substation 230 kV
2033	
2045	
2048	

TPD was allocated to the TPD candidates after first preserving for the non-operational prior commitment as described in section 2.1. The results are shown in the following table.

Table 3.5-3: TPD Allocation for Generation behind the Colorado River 500/230 kV Constraint

	Interconnection Service Capacity (MW)	Study Amount (MW)
Non-Operational Prior Commitment	507	346
Eligible TPD Candidate	875	623
TPD Allocated	0	0
Remaining TPD available	0	0
Total TPD (Non-Operational Prior Commitment + TPD Allocated + Remaining TPD available)	507	346

3.5.2 DCRT Area Constraint

The deliverability assessment identified the following overloads.

Table 3.5-4: DCRT Constraint

Overloaded Facility	Contingency	Overload
Cielo Azul-Colorado River 500 kV line	Base Case	See footnote ³

³ Following an outage of the Cielo Azul-Colorado River 500 kV line, generation at Cielo Azul and Delaney in the ISO Balancing Area that is scheduled to ISO load will need to be immediately curtailed to zero MW. During precontingency conditions that generation serving ISO load will need to be within the 2300 MW line rating.

The following figure illustrates the approximate electrical boundary of the 10% DFAX circle for the constraint.

Figure 3.5-2: Approximate electrical boundary of the projects within the 10% DFAX circle that contribute to the DCRT Area Constraint

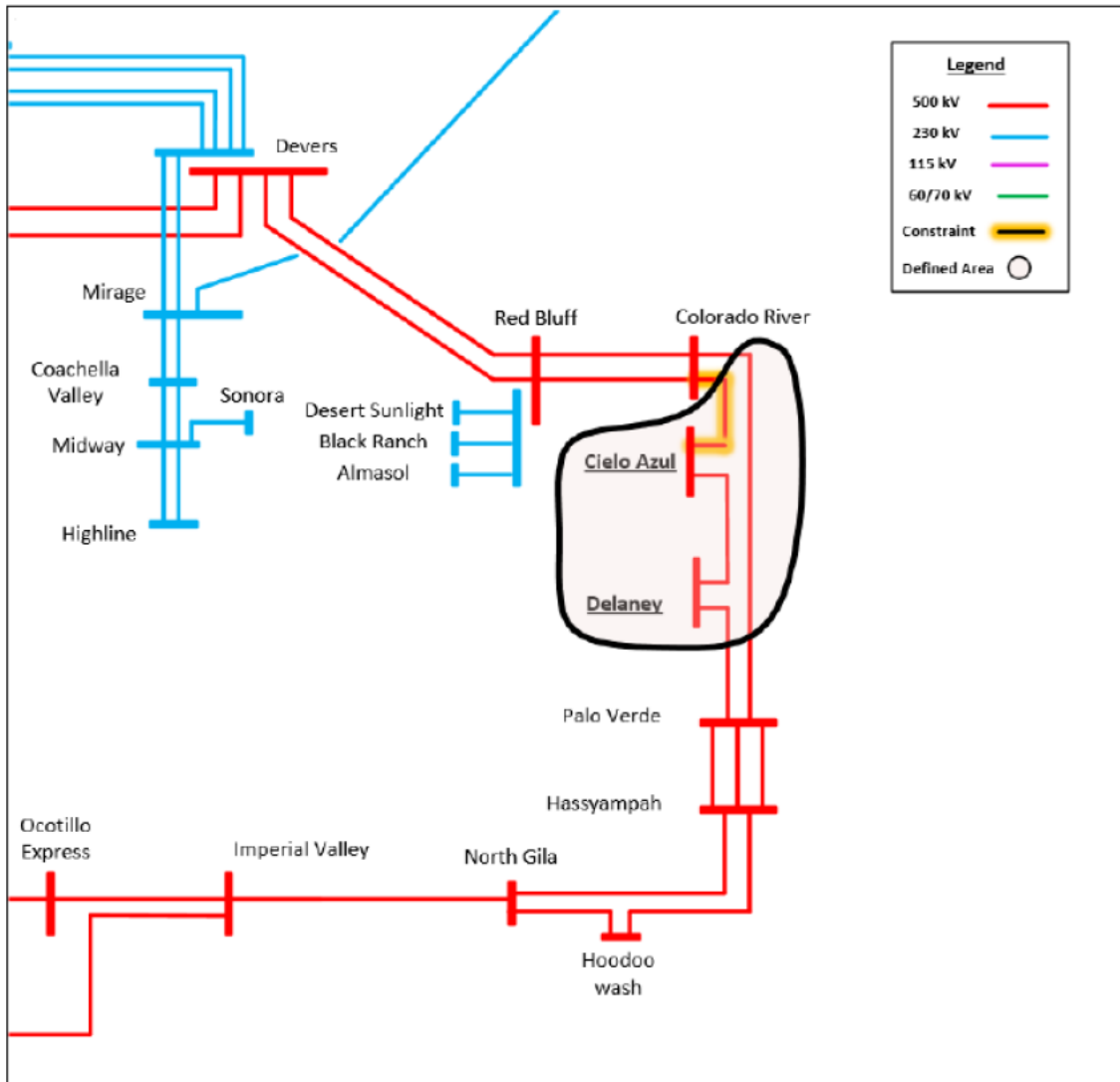

The following table shows the generation projects that are behind the constraint.

Table 3.5-5: Generation Projects Contributing to the DCRT Constraint

Queue	POI
1402	Delaney-Colorado River 500kV line
1529	Delaney-Colorado River 500kV line
1678	Delaney Substation 500 kV
2022	Cielo Azul Substation 500 kV
2025	Colorado River-Delaney 500 kV line

Queue	POI
2027	Delaney Substation 500 kV
2029	Delaney Substation 500 kV

TPD was allocated to the TPD candidates after first preserving for the non-operational prior commitment as described in section 2.1. The results are shown in the following table.

Table 3.5-6: TPD Allocation for Generation behind the DCRT Constraint

	Interconnection Service Capacity (MW)	Study Amount (MW)
Non-Operational Prior Commitment	3573	2224
Eligible TPD Candidate	2050	2050
TPD Allocated	0	0
Remaining TPD available	0	0
Total TPD (Non-Operational Prior Commitment + TPD Allocated + Remaining TPD available)	3573	2224

3.5.3 Devers-Red Bluff Area Constraint

The deliverability assessment identified the following overloads.

Table 3.5-7: Devers-Red Bluff Area Constraint

Overloaded Facility	Contingency	Overload
Devers-Red Bluff 500 kV No.1	Devers-Red Bluff 500 kV No.2	136%
Devers-Red Bluff 500 kV No.2	Devers-Red Bluff 500 kV No.1	136%

The following figure illustrates the approximate electrical boundary of the 10% DFAX circle for the constraint.

Figure 3.5-3: Approximate electrical boundary of the projects within the 10% DFAX circle that contribute to the Devers-Red Bluff Area Constraint

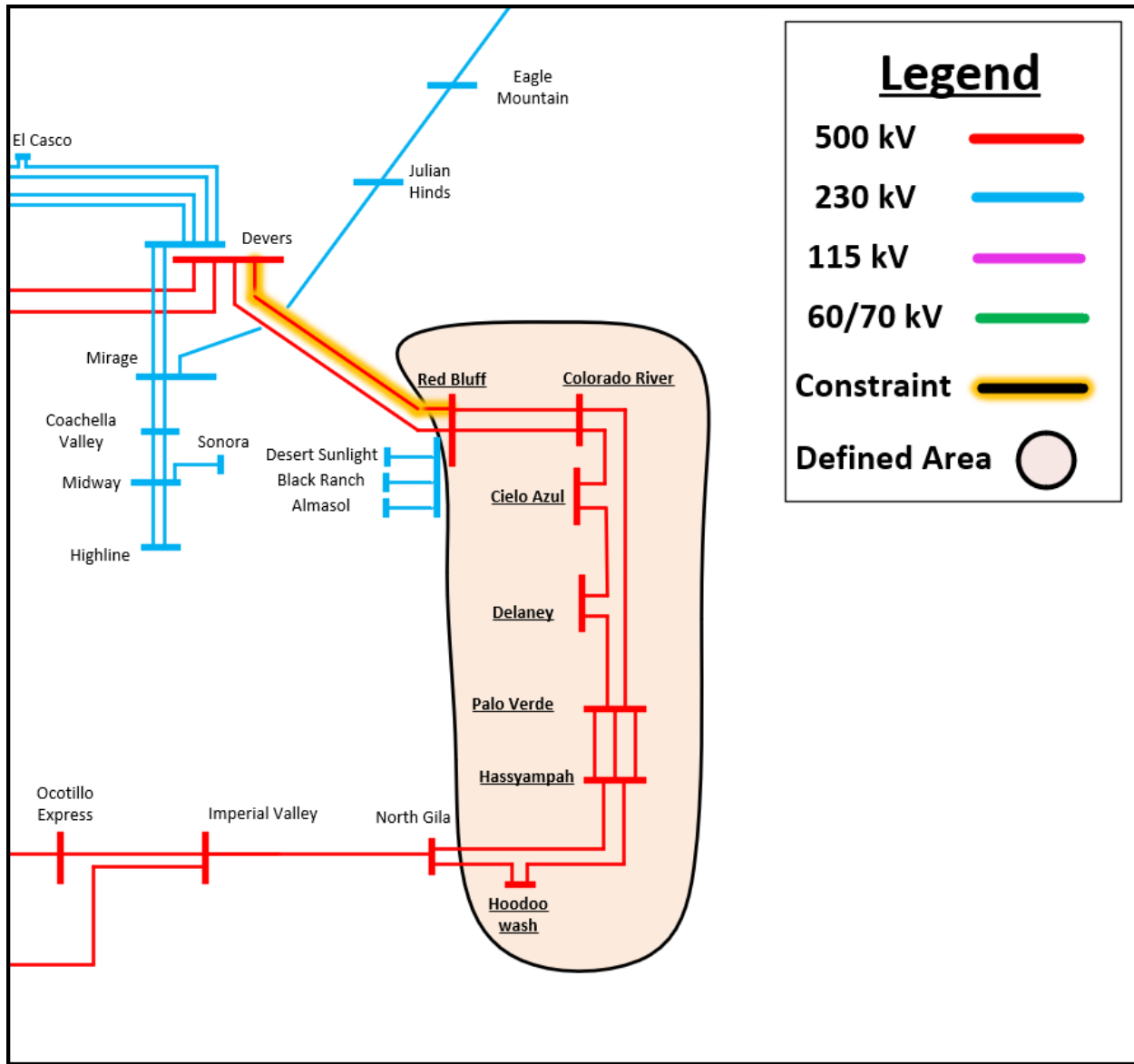

The following table shows the generation projects that are behind the constraint.

Table 3.5-8: Generation Projects Contributing to the Devers-Red Bluff Constraint

Queue	POI
421	Red Bluff Substation 220kV
1062	Hoodoo Wash Switchyard 500 kV
1200	Red Bluff Substation 230kV
1302	Red Bluff 220 kV
1402	Delaney-Colorado River 500kV line

Queue	POI
1405	Red Bluff Substation 230kV
1529	Delaney-Colorado River 500kV line
1534	Hassayampa Common Bus 500 kV
1642	Red Bluff Substation 500kV
1643	Red Bluff Substation 500kV
1678	Delaney Substation 500 kV
1761	Colorado River Substation 230kV
1764	Red Bluff Substation 230kV
1812	Hoodoo Wash Switchyard 500 kV
1818	Hassayampa Common Bus 500 kV
2022	Cielo Azul Substation 500 kV
2025	Colorado River-Delaney 500 kV line
2027	Delaney Substation 500 kV
2029	Delaney Substation 500 kV
2033	Colorado River Substation 230 kV
2036	Red Bluff Substation 220 kV
2039	Red Bluff Substation 230 kV
2041	Red Bluff Substation 230 kV
2042	Red Bluff Substation 500 kV
2045	Colorado River Substation 230 kV
2048	Colorado River Substation 230 kV
2052	Colorado River - Palo Verde 500kV
2154	Hoodoo Wash Switchyard 500 kV
	SunZia Wind

TPD was allocated to the TPD candidates after first preserving for the non-operational prior commitment as described in section 2.1. The results are shown in the following table.

Table 3.5-9: TPD Allocation for Generation behind the Devers-Red Bluff Constraint

	Interconnection Service Capacity (MW)	Study Amount (MW)
Non-Operational Prior Commitment	7076	5280
Eligible TPD Candidate	8229	6154
TPD Allocated	73	73
Remaining TPD available	0	0
Total TPD (Non-Operational Prior Commitment + TPD Allocated + Remaining TPD available)	7149	5353

For Projects behind this constraint that are receiving an allocation in this TPD cycle, the following TPP upgrades are required in addition to the Reliability Network Upgrades and Local Delivery Network Upgrades identified for the Projects:

- Devers-Red Bluff 500 kV 1 and 2 Line Upgrade
- Southern area reinforcement project
 - Imperial Valley–North of SONGS 500 kV Line and Substation
 - North of SONGS–Serrano 500 kV line
 - North Gila–Imperial Valley 500 kV line
 - Upgrade on Hoodoo Wash-North Gila and Hassayampa-North Gila Transmission Lines

3.5.4 Eagle Mountain Area Constraint

The deliverability assessment identified the following overloads.

Table 3.5-10: Eagle Mountain Constraint

Overloaded Facility	Contingency	Overload
Julian Hinds-Eagle Mountain 220 kV	Alberhill – Serrano 500kV	130%
	Valley – Alberhill 500kV	119%
	Devers-Mirage 230 kV No. 1 and No. 2	105%
	Devers-Vista 230 kV No.1 and No.2	101%
	Etiwanda-San Bernardino 230 kV and Vista-San Bernardino 230 kV	100%

The following figure illustrates the approximate electrical boundary of the 5% DFAX circle for the constraint.

Figure 3.5-4: Approximate electrical boundary of the projects within the 5% DFAX circle that contribute to the Eagle Mountain Area Constraint

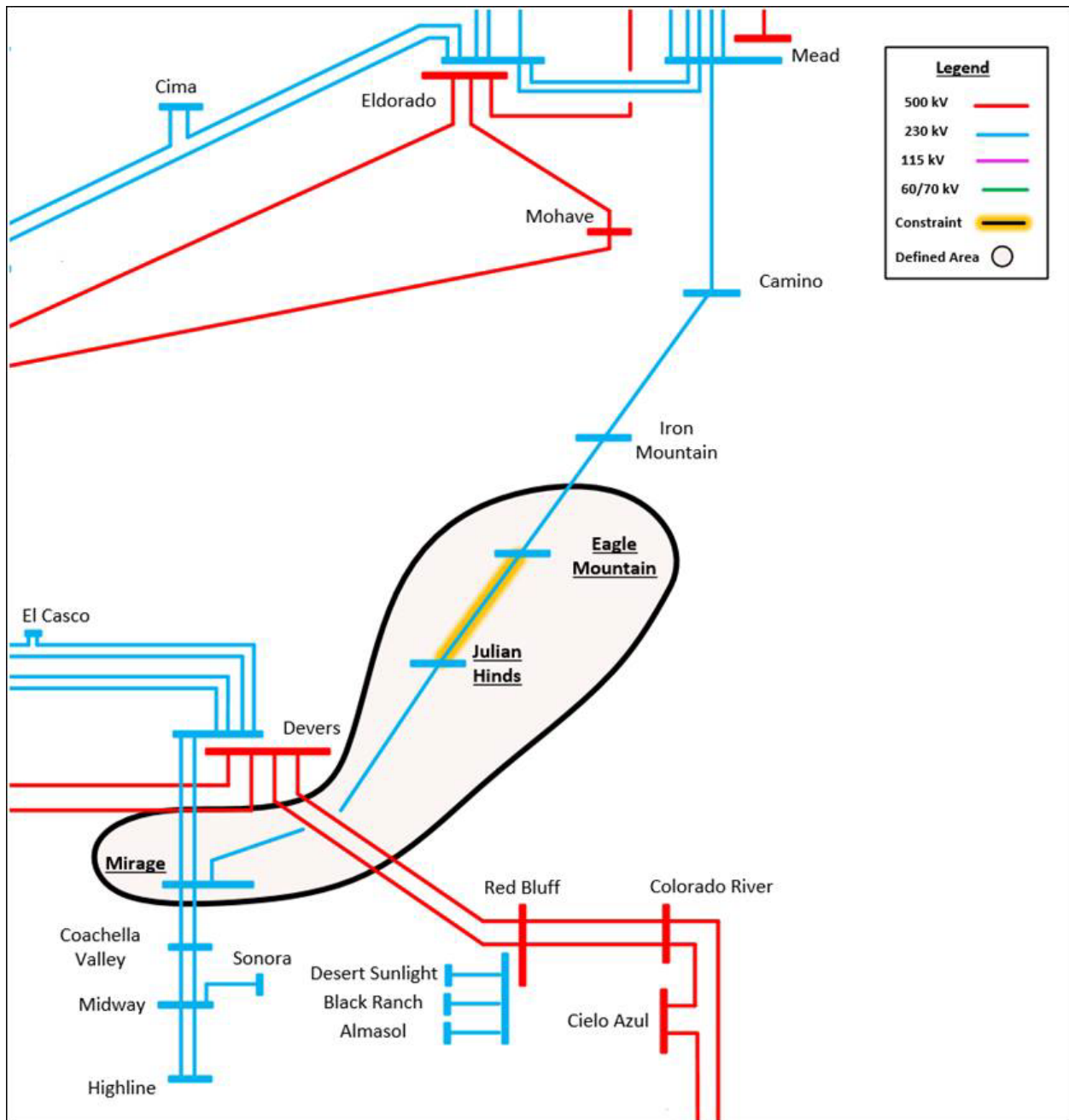

The following table shows the generation projects that are behind the constraint.

Table 3.5-11: Generation Projects Contributing to the Eagle Mountain Constraint

Queue	POI
WDT1796	Mirage 115 kV

TPD was allocated to the TPD candidates after first preserving for the non-operational prior commitment as described in section 2.1. The results are shown in the following table.

Table 3.5-12: TPD Allocation for Generation behind the Eagle Mountain Constraint

	Interconnection Service Capacity (MW)	Study Amount (MW)
Non-Operational Prior Commitment	0	0
Eligible TPD Candidate	200	200
TPD Allocated	0	0
Remaining TPD available	0	0
Total TPD (Non-Operational Prior Commitment + TPD Allocated + Remaining TPD available)	0	0

3.5.5 Mira Loma-Mesa Area Constraint

The deliverability assessment identified the following overloads.

Table 3.5-13: Mira Loma-Mesa Constraint

Overloaded Facility	Contingency	Overload
Mira Loma-Mesa 500 kV	Base Case	116%

The following figure illustrates the approximate electrical boundary of the 10% DFAX circle for the constraint.

The following table shows the generation projects that are behind the constraint.

Table 3.5-14: Generation Projects Contributing to the Mira Loma-Mesa Constraint

Queue	POI
138	Devers Substation 220 kV
421	Red Bluff Substation 220kV
1200	Red Bluff Substation 230kV
1302	Red Bluff 220 kV
1402	Delaney-Colorado River 500kV line
1405	Red Bluff Substation 230kV
1529	Delaney-Colorado River 500kV line
1642	Red Bluff Substation 500kV
1643	Red Bluff Substation 500kV
1645	Valley Substation 500kV
1646	Valley Substation 500 kV
1678	Delaney Substation 500 kV
1758	Devers Substation 230kV
1761	Colorado River Substation 230kV
1764	Red Bluff Substation 230kV
2022	Cielo Azul Substation 500 kV
2025	Colorado River-Delaney 500 kV line
2027	Delaney Substation 500 kV
2029	Delaney Substation 500 kV
2032	Etiwanda Substation 230 kV
2033	Colorado River Substation 230 kV
2034	Devers-San Bernardino line 230 kV
2036	Red Bluff Substation 220 kV
2039	Red Bluff Substation 230 kV
2041	Red Bluff Substation 230 kV
2042	Red Bluff Substation 500 kV
2045	Colorado River Substation 230 kV
2048	Colorado River Substation 230 kV
2052	Colorado River - Palo Verde 500kV
WDT1015	Devers 115 kV
WDT1551	Eisenhower: Vella 33 kV line
WDT1558	Banning 115 kV
WDT1559	Valley 115 kV
WDT1635	Tenaja 115 kV
WDT1636	Elsinore 115 kV
WDT1648	Dylan 115 kV
WDT1659	Highgrove 115 kV
WDT1669	Alder-Falcon Ridge 66 kV Line

Queue	POI
WDT1751	Skylark 115kV
WDT1753	Etiwanda-Declez 66 kV Line
WDT1775	Valley 115 kV
WDT1796	Mirage 115 kV
	SunZia Wind
32	Boulevard East 138 kV
124	Imperial Valley Substation 230 kV
1045	Otay Substation 69 kV
1047	El Cajon Substation 69 kV
1048	Escondido Substation 69 kV
1062	Hoodoo Wash Switchyard 500 kV
1166	Imperial Valley Substation 230 kV
1169	Avocado 69 kV
1175	Imperial Valley Substation 230 kV
1432	Boulevard East Substation 69 kV
1531	Imperial Valley Substation 230 kV
1532	Carrizo Gorge Switchyard 138 kV
1534	Hassayampa Common Bus 500 kV
1657	Talega Substation 138 kV
1660	East County Substation 230 kV
1662	El Cajon Substation 69 kV
1665	Imperial Valley Substation 230 kV
1669	Pomerado Substation 69 kV
1670	Silvergate Substation 230 kV
1673	Sycamore Canyon Substation 138 kV
1806	Trabuco-Capistrano 138 kV line
1812	Hoodoo Wash Switchyard 500 kV
1818	Hassayampa Common Bus 500 kV
1820	Creelman Substation 69 kV
1824	East County Substation 500 kV
2153	Silvergate Substation 230 kV
2154	Hoodoo Wash Switchyard 500 kV
2157	Encina Substation 138 kV
2162	Imperial Valley Substation 230 kV
2166	North Gila - Imperial Valley 500 kV Line
2167	Scripps Substation 69 kV
2173	Boulevard East Substation 138 kV
2176	Imperial Valley Substation 230 kV
2178	Suncrest Substation 230 kV
2180	Otay Mesa Switchyard 230 kV
2185	Otay Mesa Switchyard 230 kV
2186	San Luis Rey Substation 230 kV

Queue	POI
2188	Miguel Substation 69 kV
2192	Salt Creek Substation 69 kV
Rule 21	Alpine Substation 69 kV
W131	Santee 138kV
W162	Mesa Heights Substation 69 kV
W164	Pendleton Substation 69 kV
W165	Pendleton Substation 69 kV
W188	Pala 69kV Substation
W260	Borrego Springs Substation 69 kV
1347	Sloan Canyon Substation 230 kV
1522	Mohave 500 kV
1647	Mohave 500 kV
1649	Innovation Substation 230 kV
1650	Trout Canyon Substation 230 kV
1654	Trout Canyon Substation 230 kV
1655	Trout Canyon Substation 230 kV
1795	Mohave 500kV
1796	Eldorado Substation 230 kV
1798	Trout Canyon Substation 230 kV
1799	Trout Canyon Substation 230 kV
1800	Trout Canyon Substation 230 kV
1801	Gamebird Substation 230 kV
2140	Mohave 500kV
2141	SCE portion of Eldorado Substation 230 kV
2144	Beatty Substation 230kV
2145	Vista Substation 230kV
2147	Innovation – Desert View 230kV Line
2148	Trout Canyon Substation 230kV
2149	Trout Canyon Substation 230kV
2150	Trout Canyon Substation 500kV
1768	Mira Loma Substation 230 kV
2105	Lugo Substation 500 kV
2114	Chino Substation 230 kV
2125	Viejo Substation 230 kV
WDT1706	Francis 66 kV
WDT1711	Padua-Layfair 66 kV
WDT1719	Headstock 66 kV
WDT1761	Francis 66 kV (Chino 220 kV Substation)
1204	Kramer 230kV Bus
1207	Calcite 230kV Bus
1774	Kramer 230kV Bus
2096	Kramer-Lugo 220kV Line

Queue	POI
2097	Calcite 230kV Bus
2101	Kramer 230kV Bus
2103	Pisgah 230kV Bus
2104	Victor 230kV Bus
WDT1295	Kramer 115kV
WDT1747	Inyokern 115/33kV Bus

TPD was allocated to the TPD candidates after first preserving for the non-operational prior commitment as described in section 2.1. The results are shown in the following table.

Table 3.5-15: TPD Allocation for Generation behind the Mira Loma-Mesa Constraint

	Interconnection Service Capacity (MW)	Study Amount (MW)
Non-Operational Prior Commitment	23119	18573
Eligible TPD Candidate	16406	10783
TPD Allocated	73	73
Remaining TPD available	0	0
Total TPD (Non-Operational Prior Commitment + TPD Allocated + Remaining TPD available)	23192	18646

3.5.6 Red Bluff 500/230 kV Area Constraint

The deliverability assessment identified the following overloads.

Table 3.5-16: Red Bluff 500/230 kV Constraint

Overloaded Facility	Contingency	Overload
Red Bluff 500/230 kV Transformer No.1	Red Bluff 500/230 kV Transformer No.2	134%
Red Bluff 500/230 kV Transformer No.2	Red Bluff 500/230 kV Transformer No.1	134%

The following figure illustrates the approximate electrical boundary of the 5% DFAX circle for the constraint.

Figure 3.5-6: Approximate electrical boundary of the projects within the 5% DFAX circle that contribute to the Red Bluff 500/230 kV Constraint

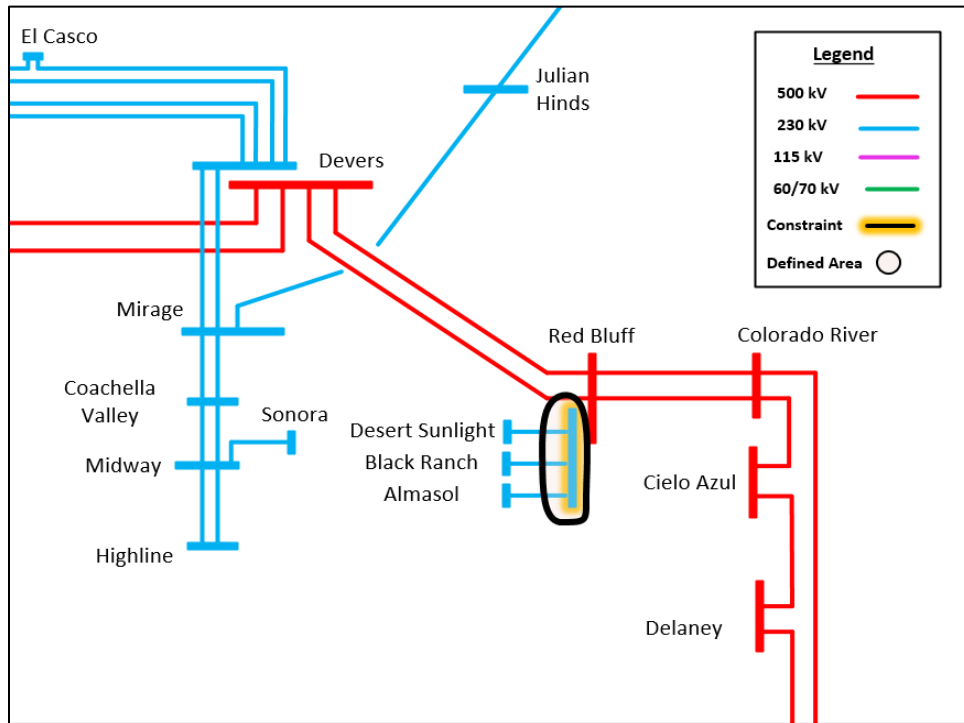

The following table shows the generation projects that are behind the constraint.

Table 3.5-17: Generation Projects Contributing to the Red Bluff 500/230 kV Constraint

Queue	POI
421	Red Bluff Substation 230 kV
1200	
1302	
1405	
1764	
2036	
2039	
2041	

TPD was allocated to the TPD candidates after first preserving for the non-operational prior commitment as described in section 2.1. The results are shown in the following table.

Table 3.5-18: TPD Allocation for Generation behind the Red Bluff 500/230 kV Constraint

	Interconnection Service Capacity (MW)	Study Amount (MW)
Non-Operational Prior Commitment	1305	1246
Eligible TPD Candidate	269.5	35
TPD Allocated	0	0
Remaining TPD available	269.5	35
Total TPD (Non-Operational Prior Commitment + TPD Allocated + Remaining TPD available)	1575	1281

3.5.7 Serrano-Alberhill-Valley Area Constraint

The deliverability assessment identified the following overloads.

Table 3.5-19: Serrano-Alberhill-Valley Constraint

Overloaded Facility	Contingency	Overload
Devers 500/230 kV Transformer No.1	Valley – Alberhill 500kV	125%
	Alberhill – Serrano 500kV	115%
Valley – Alberhill 500kV	Base Case	124%
	Devers-Vista 230 kV No. 1 and No.2	107%
	Etiwanda-San Bernardino 230 kV and Vista-San Bernardino 230 kV	107%
	Devers-El Casco 230 kV and Devers-San Bernardino 230 kV	105%
	El Casco-San Bernardino 230 kV and Devers-San Bernardino 230 kV	104%
	Delaney-Cielo Azul 500 kV	101%
Devers 500/230 kV Transformer No.2	Valley – Alberhill 500kV	123%

Overloaded Facility	Contingency	Overload
	Alberhill – Serrano 500kV	113%
Vista-Mira Loma 230 kV No.2	Etiwanda-San Bernardino 230 kV and Etiwanda-Vista 230 kV	117%
	Valley – Alberhill 500kV	101%
San Bernardino-Vista 230 kV	Devers-Vista 230 kV No. 1 and No.2	111%
Alberhill – Serrano 500kV	Base Case	111%
	Devers-Vista 230 kV No. 1 and No.2	108%
	Etiwanda-San Bernardino 230 kV and Vista-San Bernardino 230 kV	108%
	Devers-El Casco 230 kV and Devers-San Bernardino 230 kV	106%
	El Casco-San Bernardino 230 kV and Devers-San Bernardino 230 kV	104%
	Delaney-Cielo Azul 500 kV	101%
Devers-Valley 500 kV No.1	Devers-Valley 500 kV No.2	105%
Devers-Valley 500 kV No.2	Devers-Valley 500 kV No.1	105%
Vista-Etiwanda 230 kV	Vista-Mira Loma 230 kV 230 kV No.2 and Vista-Wildlife 230 kV	103%

The following figure illustrates the approximate electrical boundary of the 10% DFAX circle for the constraint.

Figure 3.5-6: Approximate electrical boundary of the projects within the 10% DFAX circle that contribute to the Serrano-Alberhill-Valley Area Constraint

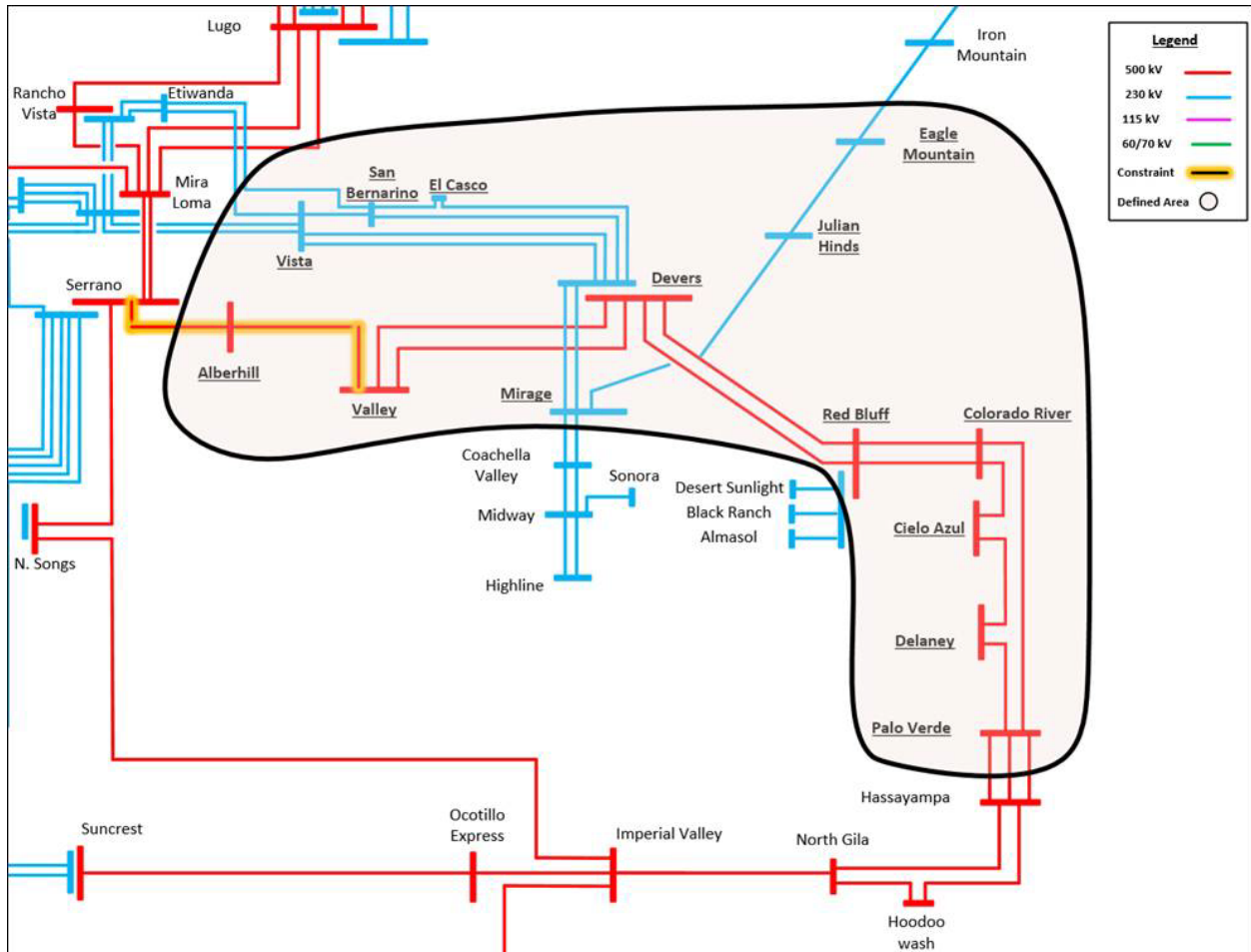

The following table shows the generation projects that are behind the constraint.

Table 3.5-20: Generation Projects Contributing to the Serrano-Alberhill-Valley Constraint

Queue	POI
138	Devers Substation 220 kV
421	Red Bluff Substation 220kV
1200	Red Bluff Substation 230kV
1302	Red Bluff 220 kV
1402	Delaney-Colorado River 500kV line
1405	Red Bluff Substation 230kV
1529	Delaney-Colorado River 500kV line
1642	Red Bluff Substation 500kV
1643	Red Bluff Substation 500kV
1645	Valley Substation 500kV
1646	Valley Substation 500 kV

Queue	POI
1678	Delaney Substation 500 kV
1758	Devers Substation 230kV
1761	Colorado River Substation 230kV
1764	Red Bluff Substation 230kV
2022	Cielo Azul Substation 500 kV
2025	Colorado River-Delaney 500 kV line
2027	Delaney Substation 500 kV
2029	Delaney Substation 500 kV
2033	Colorado River Substation 230 kV
2034	Devers-San Bernardino line 230 kV
2036	Red Bluff Substation 220 kV
2039	Red Bluff Substation 230 kV
2041	Red Bluff Substation 230 kV
2042	Red Bluff Substation 500 kV
2045	Colorado River Substation 230 kV
2048	Colorado River Substation 230 kV
2052	Colorado River - Palo Verde 500kV
WDT1015	Devers 115 kV
WDT1551	Eisenhower: Vella 33 kV line
WDT1558	Banning 115 kV
WDT1559	Valley 115 kV
WDT1635	Tenaja 115 kV
WDT1636	Elsinore 115 kV
WDT1648	Dylan 115 kV
WDT1659	Highgrove 115 kV
WDT1751	Skylark 115kV
WDT1775	Valley 115 kV
WDT1796	Mirage 115 kV

TPD was allocated to the TPD candidates after first preserving for the non-operational prior commitment as described in section 2.1. The results are shown in the following table.

Table 3.5-21: TPD Allocation for Generation behind the Serrano-Alberhill-Valley Constraint

	Interconnection Service Capacity (MW)	Study Amount (MW)
Non-Operational Prior Commitment	7886	6018
Eligible TPD Candidate	4605	4118
TPD Allocated	73	73
Remaining TPD available	0	0
Total TPD (Non-Operational Prior Commitment + TPD Allocated + Remaining TPD available)	7959	6091

For Projects behind this constraint that are receiving an allocation in this TPD cycle, the following TPD upgrades are required in addition to the Reliability Network Upgrades and Local Delivery Network Upgrades identified for the Projects:

- Devers-Valley 500 kV 1 Line Upgrade
- Serrano-Alberhill-Valley 500 kV 1 Line Upgrade
- San Bernardino-Etiwanda 230 kV 1 Line Upgrade
- San Bernardino-Vista 230 kV 1 Line Upgrade
- Vista-Etiwanda 230 kV 1 Line Upgrade
- Mira Loma-Mesa 500 kV Underground Third Cable
- Southern area reinforcement project
 - Imperial Valley–North of SONGS 500 kV Line and Substation
 - North of SONGS–Serrano 500 kV line
 - North Gila–Imperial Valley 500 kV line
 - Upgrade on Hoodoo Wash-North Gila and Hassayampa-North Gila Transmission Lines

3.5.8 SCE Eastern Area Constraint Summary

The following table provides a summary showing all of the Deliverability Constraints described above and which non-operational generation projects are impacted by those constraints.

Table 3.5-22: SCE Eastern Area Deliverability Constraint Mapping

Queue No.	Colorado River 500/230 kV	DCRT	Devers-Red Bluff	Eagle Mountain	Mira Loma-Mesa	Red Bluff 500/230 kV	Serrano-Alberhill-Valley	Lugo-Victorville
138					x		x	

Queue No.	Colorado River 500/230 kV	DCRT	Devers-Red Bluff	Eagle Mountain	Mira Loma- Mesa	Red Bluff 500/230 kV	Serrano- Alberhill-Valley	Lugo-Victorville
421			x		x	x	x	
1200			x		x	x	x	
1302			x		x	x	x	
1402		x	x		x		x	x
1405			x		x	x	x	
1529		x	x		x		x	x
1642			x		x		x	
1643			x		x		x	
1645					x		x	
1646					x		x	
1678		x	x		x		x	x
1758					x		x	
1761	x		x		x		x	
1764			x		x	x	x	
2022		x	x		x		x	x
2025		x	x		x		x	x
2027		x	x		x		x	x
2029		x	x		x		x	x
2032					x			
2033	x		x		x		x	
2034					x		x	
2036			x		x	x	x	
2039			x		x	x	x	
2041			x		x	x	x	
2042			x		x		x	
2045	x		x		x		x	
2048	x		x		x		x	
2052			x		x		x	
WDT1015					x		x	
WDT1551					x		x	
WDT1558					x		x	
WDT1559					x		x	
WDT1635					x		x	
WDT1636					x		x	
WDT1648					x		x	
WDT1659					x		x	
WDT1669					x			

Queue No.	Colorado River 500/230 kV	DCRT	Devers-Red Bluff	Eagle Mountain	Mira Loma- Mesa	Red Bluff 500/230 kV	Serrano- Alberhill-Valley	Lugo-Victorville
WDT1751					x		x	
WDT1753					x			
WDT1775					x		x	
WDT1796				x	x		x	

4. TPD Allocation Results – SDGE Area

4.1.1 San Luis Rey-San Onofre Area Constraint

The deliverability assessment identified the following overloads.

Table 4.1: San Luis Rey-San Onofre Constraint

Overloaded Facility	Contingency	Overload
San Luis Rey-San Onofre 230 kV #1	San Luis Rey-San Onofre 230 kV #2 and #3	137%
San Luis Rey-San Onofre 230 kV #1	IV-NSONGS 500 kV	109%

The following figure illustrates approximate electrical boundary of the 5% DFAX circle for the constraint.

Figure 4.1: Approximate electrical boundary of the projects within the 5% DFAX circle that contribute to the San Luis Rey-San Onofre Area Constraint

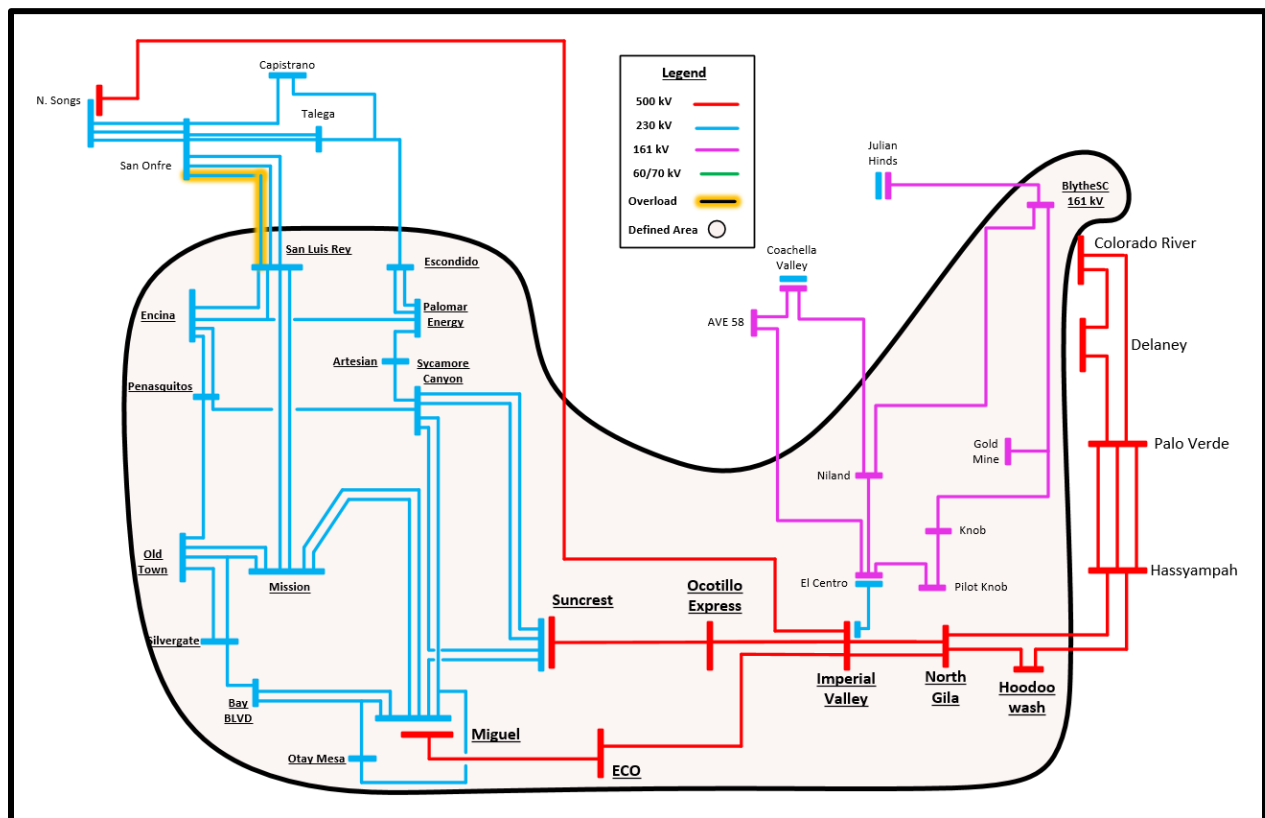

The following table shows the generation projects that are behind the constraint.

Table 4.2: Generation Projects Contributing to the San Luis Rey-San Onofre Constraint

Queue	POI
32	Boulevard East 138 kV
124	Imperial Valley Substation 230 kV
1045	Otay Substation 69 kV
1047	El Cajon Substation 69 kV
1048	Escondido Substation 69 kV
1062	Hoodoo Wash Switchyard 500 kV
1166	Imperial Valley Substation 230 kV
1169	Avocado 69 kV
1175	Imperial Valley Substation 230 kV
1432	Boulevard East Substation 69 kV
1531	Imperial Valley Substation 230 kV
1532	Carrizo Gorge Switchyard 138 kV
1660	East County Substation 230 kV
1662	El Cajon Substation 69 kV
1665	Imperial Valley Substation 230 kV
1669	Pomerado Substation 69 kV
1670	Silvergate Substation 230 kV
1673	Sycamore Canyon Substation 138 kV
1812	Hoodoo Wash Switchyard 500 kV
1820	Creelman Substation 69 kV
1824	East County Substation 500 kV
2153	Silvergate Substation 230 kV
2154	Hoodoo Wash Switchyard 500 kV
2157	Encina Substation 138 kV
2162	Imperial Valley Substation 230 kV
2166	North Gila - Imperial Valley 500 kV Line
2167	Scripps Substation 69 kV
2173	Boulevard East Substation 138 kV
2176	Imperial Valley Substation 230 kV
2178	Suncrest Substation 230 kV
2180	Otay Mesa Switchyard 230 kV
2185	Otay Mesa Switchyard 230 kV
2186	San Luis Rey Substation 230 kV
2188	Miguel Substation 69 kV
2192	Salt Creek Substation 69 kV
Rule 21	Alpine Substation 69 kV
W131	Santee 138kV
W162	Mesa Heights Substation 69 kV
W164	Pendleton Substation 69 kV
W165	Pendleton Substation 69 kV

Queue	POI
W188	Pala 69kV Substation
W260	Borrego Springs Substation 69 kV

TPD was allocated to the TPD candidates after first preserving for the non-operational prior commitment as described in section 2.1. The results are shown in the following table.

Table 4.3: TPD Allocation for Generation behind the San Luis Rey-San Onofre Constraint

	Interconnection Service Capacity (MW)	Study Amount (MW)
Non-Operational Prior Commitment	3013	2594
Eligible TPD Candidate	4426	3606
TPD Allocated	0	0
Remaining TPD available	2456	1824
Total TPD (Non-Operational Prior Commitment + TPD Allocated + Remaining TPD available)	5469	4418

The 2025 TPD study identified a new Mira Loma-Mesa area constraint resulting from the removal of the Del Amo project. As a result of this constraint, no deliverability could be allocated to generators located in the SDGE area that were seeking deliverability in the 2025 TPD allocation cycle.

4.1.2 Encina-San Luis Rey Area Constraint

The deliverability assessment identified the following overloads.

Table 4.4: Encina-San Luis Rey Constraint

Overloaded Facility	Contingency	Overload
Encina Tap-San Luis Rey 230 kV	San Luis Rey-Encina 230 kV	132%
Encina Tap-San Luis Rey 230 kV	IV-NSONGS 500 kV	120%
Encina-San Luis Rey 230 kV	San Luis Rey-Encina-Palomar 230 kV and Palomar-Artesian 230 kV	122%
Encina-San Luis Rey 230 kV	San Luis Rey-Encina-Palomar 230 kV	117%

The following figure illustrates approximate electrical boundary of the 5% DFAX circle for the constraint.

Figure 4.2: Approximate electrical boundary of the projects within the 5% DFAX circle that contribute to the Encina-San Luis Rey Constraint

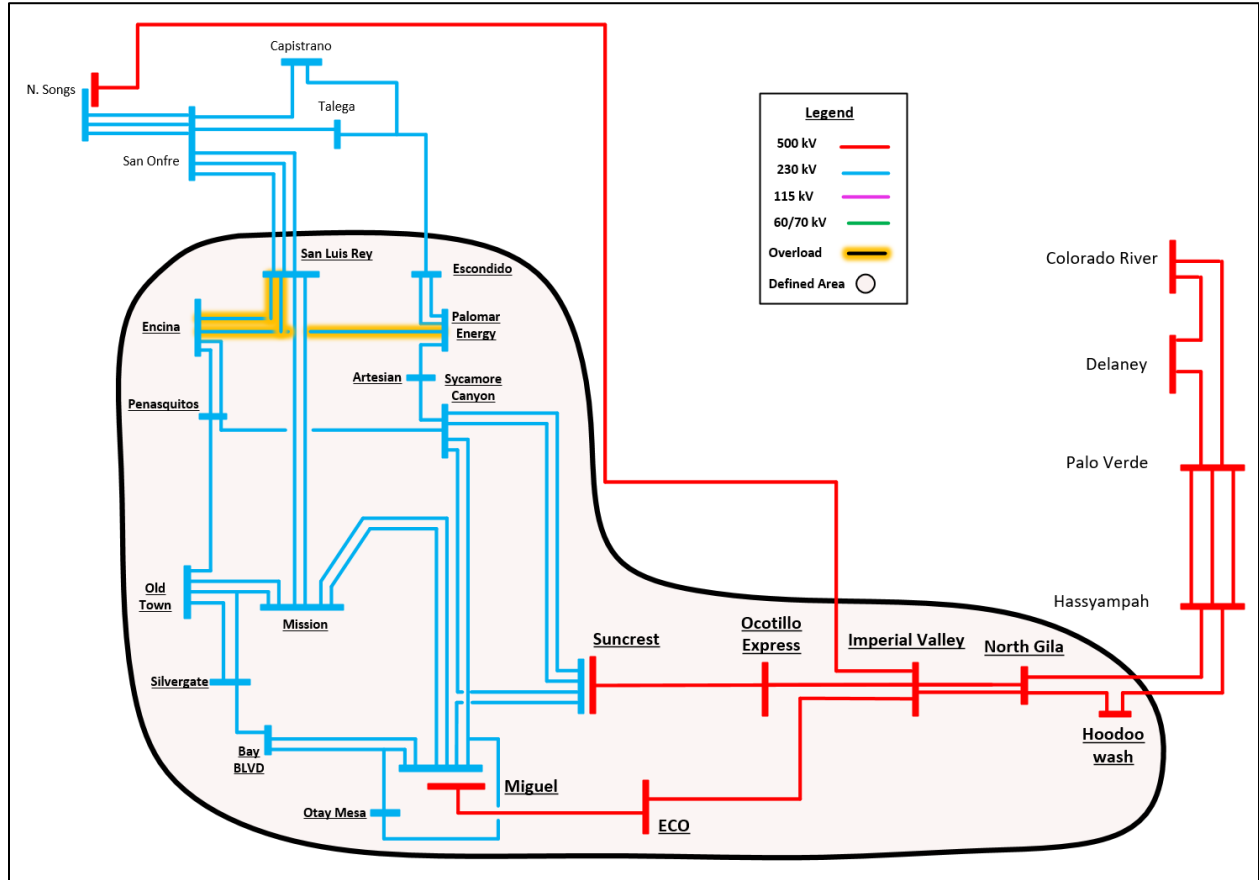

The following table shows the generation projects that are behind the constraint.

Table 4.5: Generation Projects Contributing to the Encina-San Luis Rey Constraint

Queue	POI
32	Boulevard East 138 kV
124	Imperial Valley Substation 230 kV
1045	Otay Substation 69 kV
1047	El Cajon Substation 69 kV
1048	Escondido Substation 69 kV
1166	Imperial Valley Substation 230 kV
1175	Imperial Valley Substation 230 kV
1432	Boulevard East Substation 69 kV
1531	Imperial Valley Substation 230 kV
1532	Carrizo Gorge Switchyard 138 kV

Queue	POI
1660	East County Substation 230 kV
1662	El Cajon Substation 69 kV
1665	Imperial Valley Substation 230 kV
1669	Pomerado Substation 69 kV
1670	Silvergate Substation 230 kV
1673	Sycamore Canyon Substation 138 kV
1820	Creelman Substation 69 kV
1824	East County Substation 500 kV
2153	Silvergate Substation 230 kV
2157	Encina Substation 138 kV
2162	Imperial Valley Substation 230 kV
2166	North Gila - Imperial Valley 500 kV Line
2167	Scripps Substation 69 kV
2173	Boulevard East Substation 138 kV
2176	Imperial Valley Substation 230 kV
2178	Suncrest Substation 230 kV
2180	Otay Mesa Switchyard 230 kV
2185	Otay Mesa Switchyard 230 kV
2188	Miguel Substation 69 kV
2192	Salt Creek Substation 69 kV
Rule 21	Alpine Substation 69 kV
W131	Santee 138kV
W162	Mesa Heights Substation 69 kV
W188	Pala 69kV Substation
W260	Borrego Springs Substation 69 kV

TPD was allocated to the TPD candidates after first preserving for the non-operational prior commitment as described in section 2.1. The results are shown in the following table.

Table 4.6: TPD Allocation for Generation behind the Encina-San Luis Rey Constraint

	Interconnection Service Capacity (MW)	Study Amount (MW)
Non-Operational Prior Commitment	2663	2468
Eligible TPD Candidate	3676	3044
TPD Allocated	0	0
Remaining TPD available	2206	1574
Total TPD (Non-Operational Prior Commitment + TPD Allocated + Remaining TPD available)	4869	4041

The 2025 TPD study identified a new Mira Loma-Mesa area constraint resulting from the removal of the Del Amo project. As a result of this constraint, no deliverability could be allocated to generators located in the SDGE area that were seeking deliverability in the 2025 TPD allocation cycle.

4.1.3 Silvergate-Old Town Area Constraint

The deliverability assessment identified the following overloads.

Table 4.7: Silvergate-Old Town Constraint

Overloaded Facility	Contingency	Overload
Silvergate-Vine 230 kV	Silvergate-Old Town-Mission 230 kV	172%
Silvergate-Vine 230 kV	Old Town-Mission 230 kV and Silvergate-Mission-Old Town 230 kV	161%
Silvergate-Old Town Tap 230 kV	Silvergate-Vine 230 kV	167%
Silvergate-Old Town Tap 230 kV	Vine-Old Town 230 kV	141%

The following figure illustrates approximate electrical boundary of the 5% DFAX circle for the constraint.

Figure 4.3: Approximate electrical boundary of the projects within the 5% DFX circle that contribute to the Silvergate-Old Town Constraint

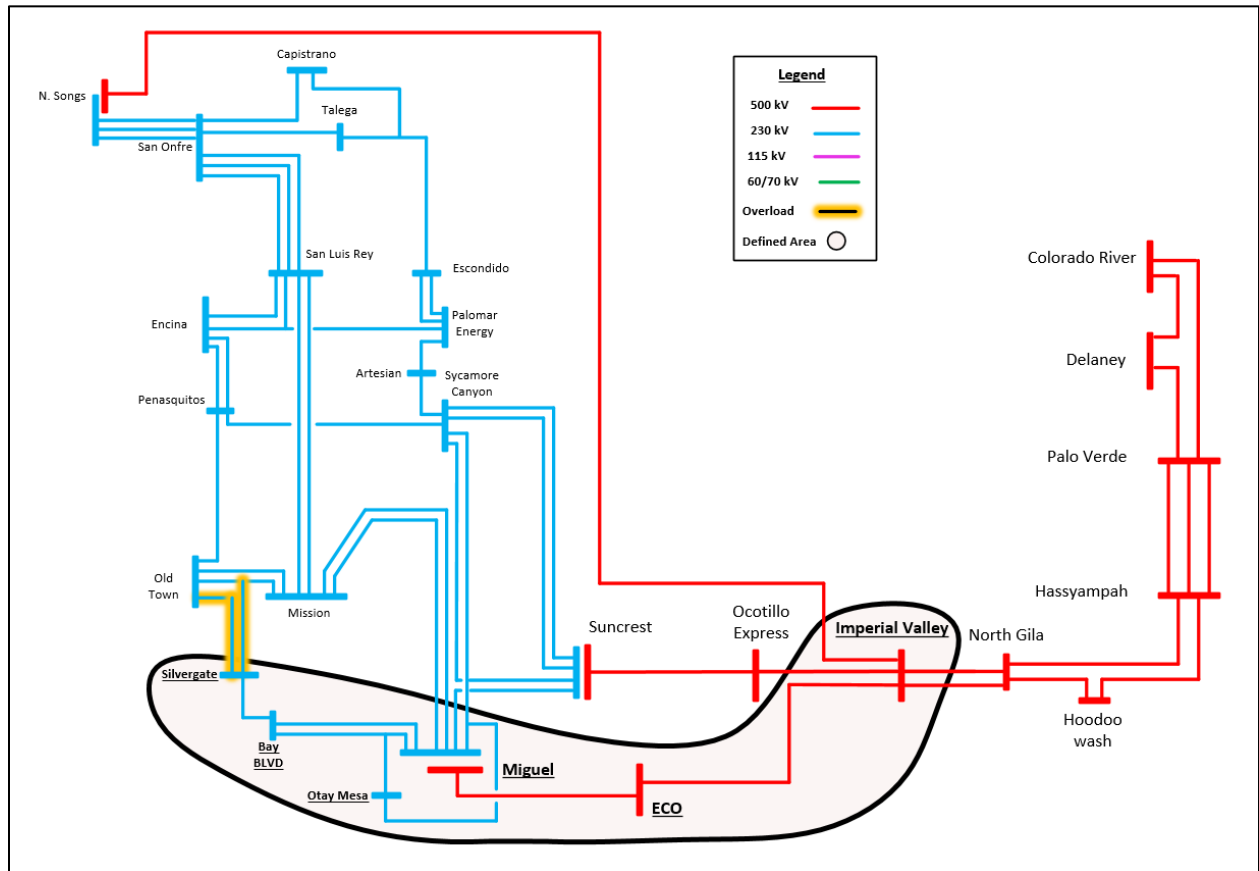

The following table shows the generation projects that are behind the constraint.

Table 4.8: Generation Projects Contributing to the Silvergate-Old Town Constraint

Queue	POI
32	Boulevard East 138 kV
1045	Otay Substation 69 kV
1047	El Cajon Substation 69 kV
1432	Boulevard East Substation 69 kV
1532	Carrizo Gorge Switchyard 138 kV
1660	East County Substation 230 kV
1670	Silvergate Substation 230 kV
1824	East County Substation 500 kV
2153	Silvergate Substation 230 kV
2173	Boulevard East Substation 138 kV
2180	Otay Mesa Switchyard 230 kV

Queue	POI
2185	Otay Mesa Switchyard 230 kV
2188	Miguel Substation 69 kV
2192	Salt Creek Substation 69 kV
Rule 21	Alpine Substation 69 kV

TPD was allocated to the TPD candidates after first preserving for the non-operational prior commitment as described in section 2.1. The results are shown in the following table.

Table 4.9: TPD Allocation for Generation behind the Silvergate-Old Town Constraint

	Interconnection Service Capacity (MW)	Study Amount (MW)
Non-Operational Prior Commitment	849	654
Eligible TPD Candidate	1854	1222
TPD Allocated	0	0
Remaining TPD available	1354	722
Total TPD (Non-Operational Prior Commitment + TPD Allocated + Remaining TPD available)	2204	1376

The 2025 TPD study identified a new Mira Loma-Mesa area constraint resulting from the removal of the Del Amo project. As a result of this constraint, no deliverability could be allocated to generators located in the SDGE area that were seeking deliverability in the 2025 TPD allocation cycle.

4.1.4 Silvergate-Boulevard Area Constraint

The deliverability assessment identified the following overloads.

Table 4.10: Silvergate-Bay Boulevard Constraint

Overloaded Facility	Contingency	Overload
Silvergate-Bay Boulevard 230 kV	Miguel-Mission 230 kV #1 and #2	126%
Silvergate-Bay Boulevard 230 kV	IV-NSONGS 500 kV	124%

The following figure illustrates approximate electrical boundary of the 5% DFAX circle for the constraint.

Figure 4.4: Approximate electrical boundary of the projects within the 5% DFAQ circle that contribute to the Silvergate-Bay Boulevard Constraint

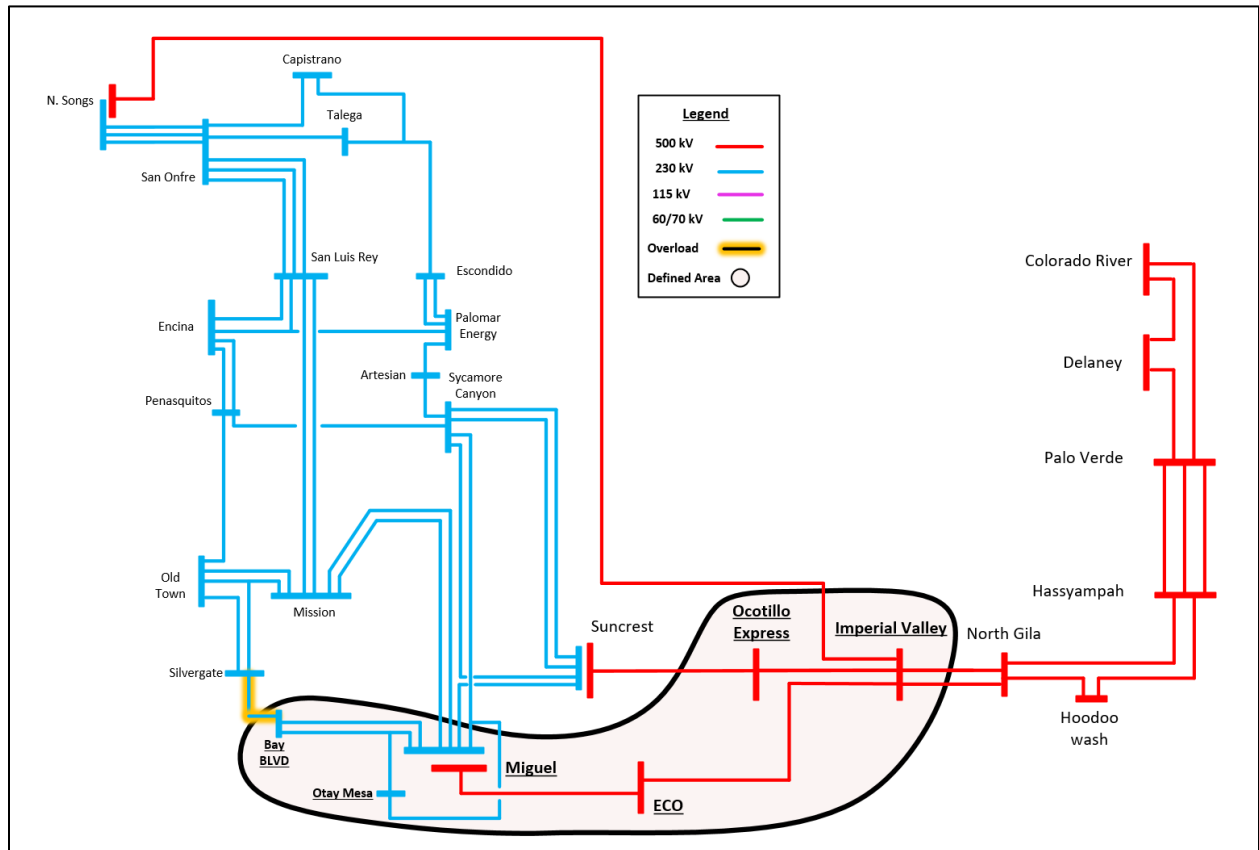

The following table shows the generation projects that are behind the constraint.

Table 4.11: Generation Projects Contributing to the Silvergate-Bay Boulevard Constraint

Queue	POI
32	Boulevard East 138 kV
124	Imperial Valley Substation 230 kV
1045	Otay Substation 69 kV
1166	Imperial Valley Substation 230 kV
1175	Imperial Valley Substation 230 kV
1432	Boulevard East Substation 69 kV
1531	Imperial Valley Substation 230 kV
1532	Carrizo Gorge Switchyard 138 kV
1660	East County Substation 230 kV
1665	Imperial Valley Substation 230 kV
1812	Hoodoo Wash Switchyard 500 kV
1824	East County Substation 500 kV

Queue	POI
2162	Imperial Valley Substation 230 kV
2166	North Gila - Imperial Valley 500 kV Line
2173	Boulevard East Substation 138 kV
2176	Imperial Valley Substation 230 kV
2180	Otay Mesa Switchyard 230 kV
2185	Otay Mesa Switchyard 230 kV
2188	Miguel Substation 69 kV
2192	Salt Creek Substation 69 kV

TPD was allocated to the TPD candidates after first preserving for the non-operational prior commitment as described in section 2.1. The results are shown in the following table.

Table 4.12: TPD Allocation for Generation behind the Silvergate-Bay Boulevard Constraint

	Interconnection Service Capacity (MW)	Study Amount (MW)
Non-Operational Prior Commitment	1992	1797
Eligible TPD Candidate	2706	2074
TPD Allocated	0	0
Remaining TPD available	2106	1474
Total TPD (Non-Operational Prior Commitment + TPD Allocated + Remaining TPD available)	4098	3271

The 2025 TPD study identified a new Mira Loma-Mesa area constraint resulting from the removal of the Del Amo project. As a result of this constraint, no deliverability could be allocated to generators located in the SDGE area that were seeking deliverability in the 2025 TPD allocation cycle.

4.1.5 East of Miguel Area Constraint

This constraint was evaluated after removing TPD candidates that did not receive an allocation for the above constraints. With all approved TPP upgrades modeled, this constraint was not binding in this study.

The following figure and table show the approximate electrical boundary of the 5% DFAX circle for the constraint.

Figure 4.5: Approximate electrical boundary of the projects within the 5% DFAX circle that contribute to the East of Miguel Constraint

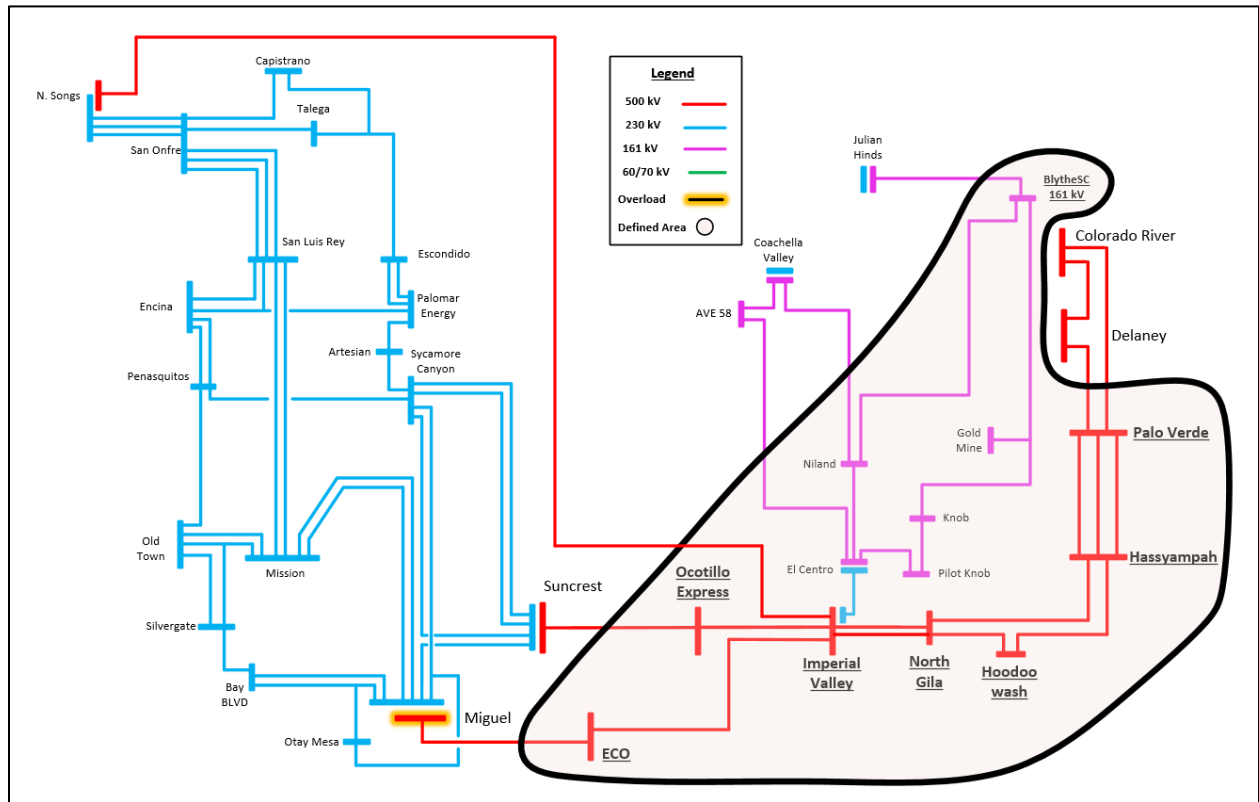

Table 4.13: Generation Projects Contributing to the East of Miguel Deliverability Constraint

Queue	POI
32	Boulevard East 138 kV
124	Imperial Valley Substation 230 kV
1062	Hoodoo Wash Switchyard 500 kV
1166	Imperial Valley Substation 230 kV
1175	Imperial Valley Substation 230 kV
1432	Boulevard East Substation 69 kV
1531	Imperial Valley Substation 230 kV
1532	Carrizo Gorge Switchyard 138 kV
1534	Hassayampa Common Bus 500 kV
1660	East County Substation 230 kV
1665	Imperial Valley Substation 230 kV
1812	Hoodoo Wash Switchyard 500 kV
1818	Hassayampa Common Bus 500 kV
1824	East County Substation 500 kV
2154	Hoodoo Wash Switchyard 500 kV

Queue	POI
2162	Imperial Valley Substation 230 kV
2166	North Gila - Imperial Valley 500 kV Line
2173	Boulevard East Substation 138 kV
2176	Imperial Valley Substation 230 kV

TPD was allocated to the TPD candidates after first preserving for the non-operational prior commitment as described in section 2.1. The results are shown in the following table.

Table 4.14: TPD Allocation for Generation behind the East of Miguel Constraint

	Interconnection Service Capacity (MW)	Study Amount (MW)
Non-Operational Prior Commitment	N/A, constraint not binding	
Eligible TPD Candidate		
TPD Allocated		
Remaining TPD available		
Total TPD (Non-Operational Prior Commitment + TPD Allocated + Remaining TPD available)		

The 2025 TPD study identified a new Mira Loma-Mesa area constraint resulting from the removal of the Del Amo project. As a result of this constraint, no deliverability could be allocated to generators located in the SDGE area that were seeking deliverability in the 2025 TPD allocation cycle.

4.1.6 Internal San Diego Area (Melrose Tap-San Marcos) Constraint

This constraint was evaluated after removing TPD candidates that did not receive an allocation for the above constraints. With all approved TPP upgrades modeled, this constraint was not binding in this study.

The following figure and table show the approximate electrical boundary of the 5% DFAX circle for the constraint.

Figure 4.6: Approximate electrical boundary of the projects within the 5% DFX circle that contribute to the Internal San Diego Area (Melrose Tap-San Marcos) Constraint

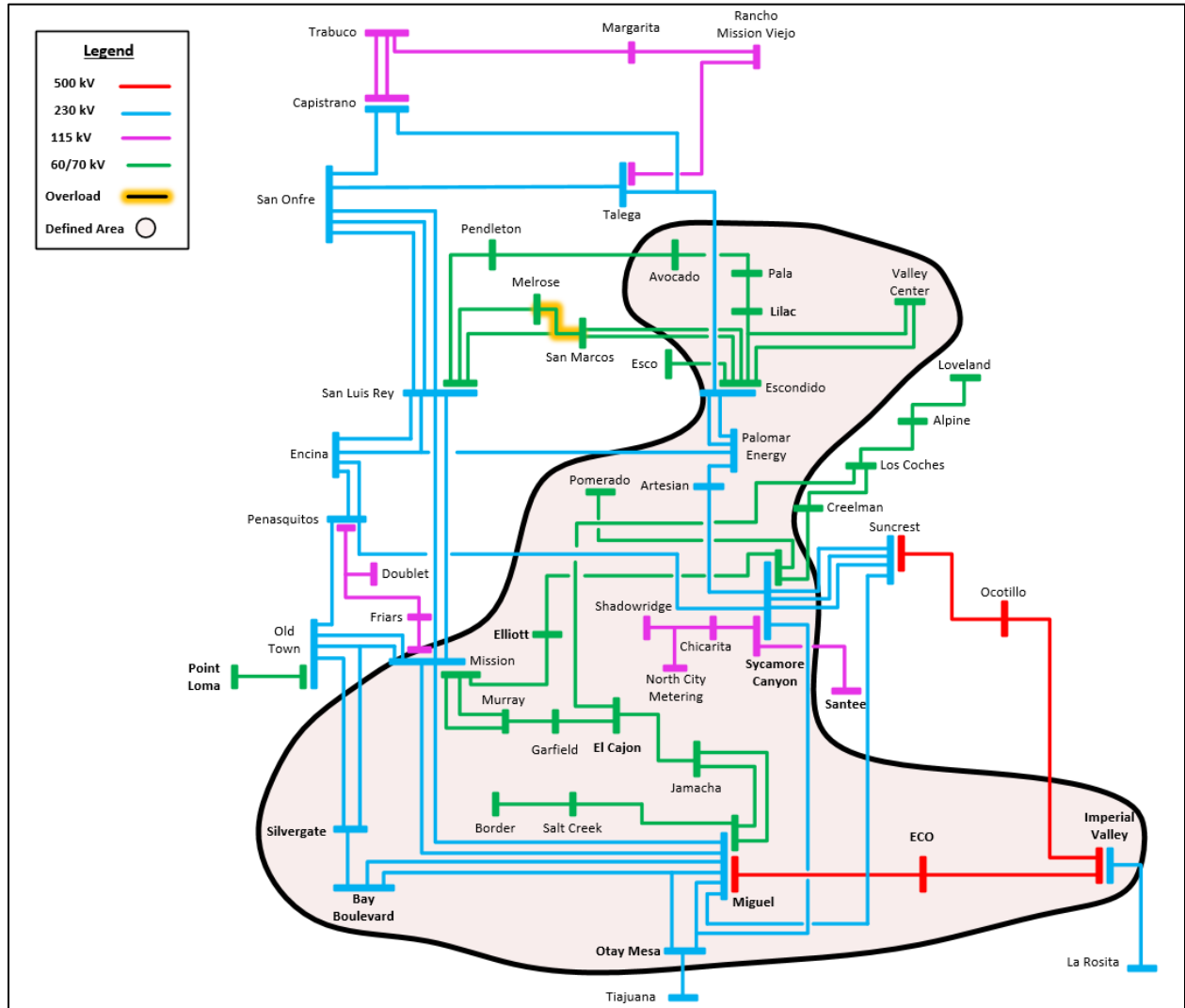

The following table shows the generation projects that are behind the constraint.

Table 4.15: Generation Projects Contributing to the Internal San Diego Area (Melrose Tap-San Marcos) Constraint

Queue	POI
1048	Escondido Substation 69 kV
1669	Pomerado Substation 69 kV
1670	Silvergate Substation 230 kV
1673	Sycamore Canyon Substation 138 kV
W260	Borrego Springs Substation 69 kV

TPD was allocated to the TPD candidates after first preserving for the non-operational prior commitment as described in section 2.1. The results are shown in the following table.

Table 4.16: TPD Allocation for Generation behind the Internal San Diego Area (Melrose Tap-San Marcos) Constraint

	Interconnection Service Capacity (MW)	Study Amount (MW)
Non-Operational Prior Commitment	N/A, constraint not binding	
Eligible TPD Candidate		
TPD Allocated		
Remaining TPD available		
Total TPD (Non-Operational Prior Commitment + TPD Allocated + Remaining TPD available)		

The 2025 TPD study identified a new Mira Loma-Mesa area constraint resulting from the removal of the Del Amo project. As a result of this constraint, no deliverability could be allocated to generators located in the SDGE area that were seeking deliverability in the 2025 TPD allocation cycle.

4.1.7 Internal San Diego Area (Doublet Tap-Friars) Constraint

This constraint was evaluated after removing TPD candidates that did not receive an allocation for the above constraints. With all approved TPP upgrades modeled, this constraint was not binding in this study.

The following figure and table show the approximate electrical boundary of the 5% DFAX circle for the constraint.

Figure 4.7: Approximate electrical boundary of the projects within the 5% DFX circle that contribute to the Internal San Diego Area (Doublet Tap-Friars) Constraint

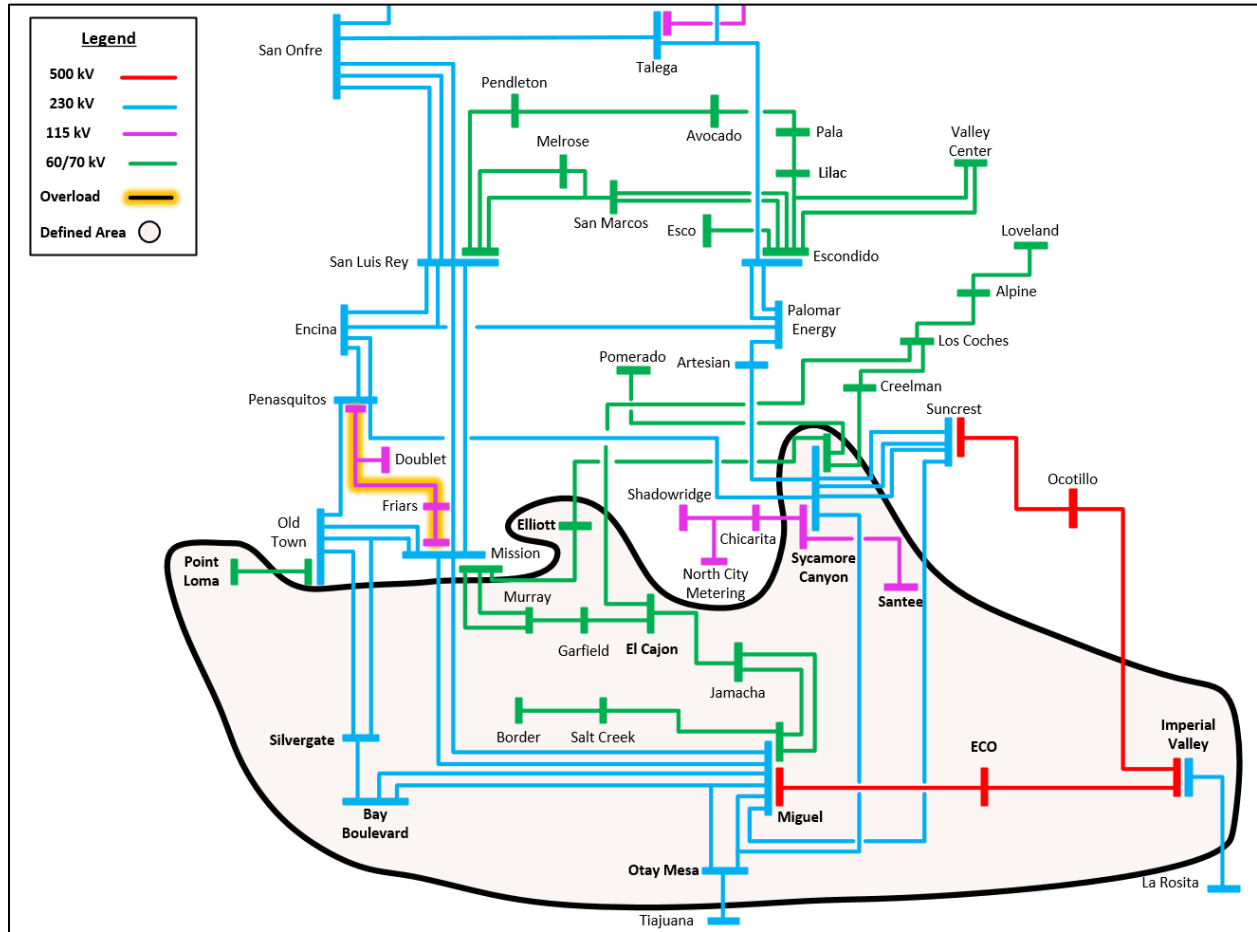

The following table shows the generation projects that are behind the constraint.

Table 4.17: Generation Projects Contributing to the Internal San Diego Area (Doublet Tap-Friars) Constraint

Queue	POI
32	Boulevard East 138 kV
124	Imperial Valley Substation 230 kV
1045	Otay Substation 69 kV
1047	El Cajon Substation 69 kV
1166	Imperial Valley Substation 230 kV
1175	Imperial Valley Substation 230 kV
1531	Imperial Valley Substation 230 kV
1662	El Cajon Substation 69 kV
1665	Imperial Valley Substation 230 kV
1670	Silvergate Substation 230 kV

Queue	POI
1673	Sycamore Canyon Substation 138 kV
2166	North Gila - Imperial Valley 500 kV Line
2173	Boulevard East Substation 138 kV
2176	Imperial Valley Substation 230 kV
Rule 21	Alpine Substation 69 kV
W131	Santee 138kV
W162	Mesa Heights Substation 69 kV

TPD was allocated to the TPD candidates after first preserving for the non-operational prior commitment as described in section 2.1. The results are shown in the following table.

Table 4.18: TPD Allocation for Generation behind the Internal San Diego Area (Doublet Tap-Friars) Constraint

	Interconnection Service Capacity (MW)	Study Amount (MW)
Non-Operational Prior Commitment	N/A, constraint not binding	
Eligible TPD Candidate		
TPD Allocated		
Remaining TPD available		
Total TPD (Non-Operational Prior Commitment + TPD Allocated + Remaining TPD available)		

The 2025 TPD study identified a new Mira Loma-Mesa area constraint resulting from the removal of the Del Amo project. As a result of this constraint, no deliverability could be allocated to generators located in the SDGE area that were seeking deliverability in the 2025 TPD allocation cycle.

4.1.8 Sycamore Area Constraint

This constraint was evaluated after removing TPD candidates that did not receive an allocation for the above constraints. With all approved TPP upgrades modeled, this constraint was not binding in this study.

The following figure and table show the approximate electrical boundary of the 5% DFAX circle for the constraint.

Figure 4.8: Approximate electrical boundary of the projects within the 5% DFX circle that contribute to the Sycamore Constraint

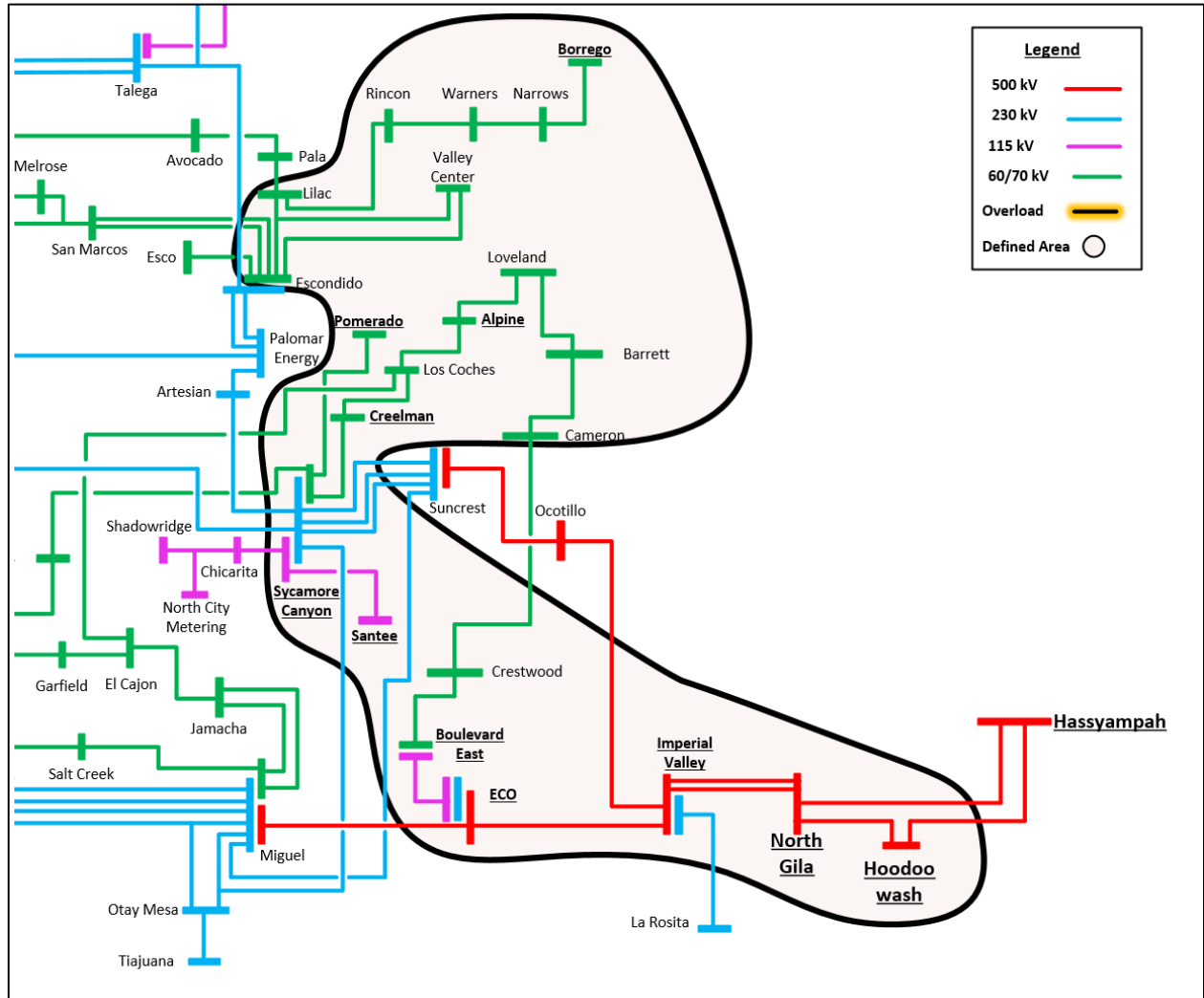

The following table shows the generation projects that are behind the constraint.

Table 4.19: Generation Projects Contributing to the Sycamore Constraint

Queue	POI
32	Boulevard East 138 kV
124	Imperial Valley Substation 230 kV
1062	Hoodoo Wash Switchyard 500 kV
1166	Imperial Valley Substation 230 kV
1175	Imperial Valley Substation 230 kV
1432	Boulevard East Substation 69 kV
1531	Imperial Valley Substation 230 kV
1532	Carrizo Gorge Switchyard 138 kV

Queue	POI
1660	East County Substation 230 kV
1665	Imperial Valley Substation 230 kV
1669	Pomerado Substation 69 kV
1673	Sycamore Canyon Substation 138 kV
1812	Hoodoo Wash Switchyard 500 kV
1824	East County Substation 500 kV
2154	Hoodoo Wash Switchyard 500 kV
2162	Imperial Valley Substation 230 kV
2166	North Gila - Imperial Valley 500 kV Line
2173	Boulevard East Substation 138 kV
2176	Imperial Valley Substation 230 kV
Rule 21	Alpine Substation 69 kV
W131	Santee 138kV
W260	Borrego Springs Substation 69 kV

TPD was allocated to the TPD candidates after first preserving for the non-operational prior commitment as described in section 2.1. The results are shown in the following table.

Table 4.20: TPD Allocation for Generation behind the Sycamore Constraint

	Interconnection Service Capacity (MW)	Study Amount (MW)
Non-Operational Prior Commitment	N/A, constraint not binding	
Eligible TPD Candidate		
TPD Allocated		
Remaining TPD available		
Total TPD (Non-Operational Prior Commitment + TPD Allocated + Remaining TPD available)		

The 2025 TPD study identified a new Mira Loma-Mesa area constraint resulting from the removal of the Del Amo project. As a result of this constraint, no deliverability could be allocated to generators located in the SDGE area that were seeking deliverability in the 2025 TPD allocation cycle.

4.1.9 SDGE Area Constraint Summary

The following table provides a summary of the Deliverability Constraints described above and which non-operational generation projects are impacted by those constraints.

Table 4.21: SDGE Area Deliverability Constraint Mapping

Queue	San Luis Rey-San Onofre Constraint	Encina-San Luis Rey Constraint	Silvergate-Old Town Constraint	Silvergate-Bay Boulevard Constraint	East of Miguel Constraint	Internal (Melrose-San Marcos) Constraint	Internal (Friars-Doulet-Mission) Constraint	Sycamore Constraint	Mira Loma-Mesa constraint	Devers-Red Bluff Constraint	Lugo-Victorville Constraint
32	x	x	x	x	x		x	x	x		
124	x	x		x	x		x	x	x		
1045	x	x	x	x			x		x		
1047	x	x	x				x		x		
1048	x	x				x			x		
1062	x				x			x	x	x	x
1166	x	x		x	x		x	x	x		
1169	x								x		
1175	x	x		x	x		x	x	x		
1432	x	x	x	x	x			x	x		
1531	x	x		x	x		x	x	x		
1532	x	x	x	x	x			x	x		
1534					x				x	x	x
1657									x		
1660	x	x	x	x	x			x	x		
1662	x	x					x		x		
1665	x	x		x	x		x	x	x		
1669	x	x				x		x	x		
1670	x	x	x			x	x		x		
1673	x	x				x	x	x	x		
1806									x		
1812	x			x	x			x	x	x	x
1818					x				x	x	x
1820	x	x							x		
1824	x	x	x	x	x			x	x		
2153	x	x	x						x		
2154	x				x			x	x	x	x
2157	x	x							x		
2162	x	x		x	x			x	x		

2025 TPD Allocation

Queue	San Luis Rey-San Onofre Constraint	Encina-San Luis Rey Constraint	Silvergate-Old Town Constraint	Silvergate-Bay Boulevard Constraint	East of Miguel Constraint	Internal (Melrose-San Marcos) Constraint	Internal (Friars-Doulet-Mission) Constraint	Sycamore Constraint	Mira Loma-Mesa constraint	Devers-Red Bluff Constraint	Lugo-Victorville Constraint
2166	x	x		x	x		x	x	x		
2167	x	x							x		
2173	x	x	x	x	x		x	x	x		
2176	x	x		x	x		x	x	x		
2178	x	x							x		
2180	x	x	x	x					x		
2185	x	x	x	x					x		
2186	x								x		
2188	x	x	x	x					x		
2192	x	x	x	x					x		
Rule 21	x	x	x				x	x	x		
W131	x	x					x	x	x		
W162	x	x					x		x		
W164	x								x		
W165	x								x		
W188	x	x							x		
W260	x	x				x		x	x		

5. TPD Allocation Results – PGE Area

5.1 North of Greater Bay Interconnection Area Constraints

5.1.1 Collinsville-Tesla 500 kV Area Constraint

The deliverability assessment identified the following overloads:

Table 5.1: Collinsville-Tesla 500 kV Area Constraint

Overloaded Facility	Contingency	Overload
Collinsville-Tesla 500 kV	Table Mountain-Tesla 500 kV	101%

This constraint limits deliverability of generators in the Greater Bay Area, North of Greater Bay Area and PG&E South 500 kV. The following figure illustrates approximate electrical boundary of the 10% Dfax circle for 500 kV constraints, and 5% DFAX circle for other lower kV constraints.

Figure 5.1: Approximate electrical boundary of the projects within the 10% Dfax circle for 500 kV, and 5% DFAX circle for other lower kV, that contribute to the Collinsville-Tesla 500 kV Area Constraint

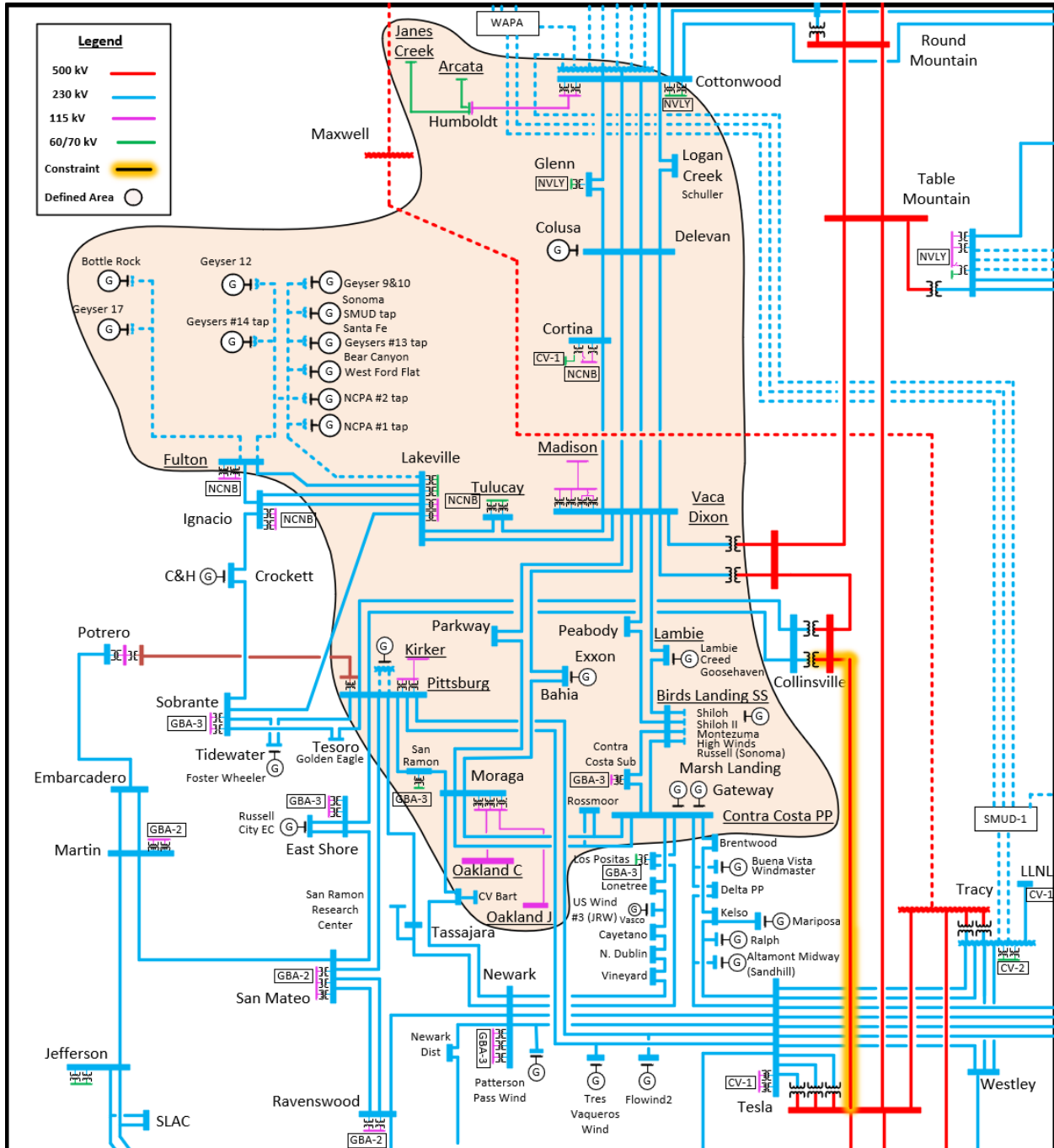

TPD was allocated to the TPD candidates after first preserving for the non-operational prior commitment as described in section 2.1. The results are shown in the following table.

Table 5.2 TPD allocation for generation behind the Collinsville-Tesla 500 kV Area Constraint⁴

	Interconnection Service Capacity (MW)	Study Amount (MW)
Non-Operational Prior Commitment (MW)	3566	2685
Eligible TPD Candidate (MW)	2634	2634
TPD Allocated (MW)	1513	1513
Remaining TPD Available	0	0
Total TPD (Non-Operational Prior Commitment + TPD Allocated + Remaining TPD available)	5079	4198

Table 5.3: Generation Projects Contributing to the Collinsville-Tesla 500 kV Area Constraint

Queue	POI
1842	Lambie 230 kV
1843	Lambie 230 kV
1846	Fulton 230 kV
1850	Birds Landing 230 kV
1854	Vaca-Dixon 230 kV
1856	Vaca-Dixon 115 kV
1871	Palermo 115 kV
1880	Oakland C 115 kV
1892	Contra Costa PP 230 kV
1915	Contra Costa PP 230 kV
0141CONV	Vaca-Dixon 115 kV
2179-WD	JANES CREEK SUB
2595-WD	MADISON SUB
2622-WD	ARCATA SUB
2758-WD	OAKLAND J SUB
2762-WD	TULUCAY SUB
3258-WD	ARCATA SUB

For Projects behind this constraint that are receiving an allocation in this TPD cycle, the following TPP upgrades are required in addition to the Network Upgrades identified for the Projects in their latest report:

- Humbolt to Fern Road 500kV line
- Humbolt 500kV substation with 500kV line to Collinsville

⁴ This area constraint has multiple overloads. Numbers provided in the table are based on the most representative constraint.

5.2 Greater Bay Interconnection Area Constraints

5.2.1 Bellota Area Constraint

The deliverability assessment identified the following overloads:

Table 5.4: Bellota Area Constraint

Overloaded Facility	Contingency	Overload
Bellota-Q1109 115kV Line	Base Case	164%
Bellota 230/115 kV Bank #1	Bellota 230/115 kV Bank #2	155%
Bellota 230/115 kV Bank #2	Bellota 230/115 kV Bank #1	139%

This constraint limits deliverability of generators in the Greater Bay Area and North of Greater Bay Area. The following figure illustrates approximate electrical boundary of the 5% DFAX circle for the constraint.

Figure 5.2: Approximate electrical boundary of the projects within the 5% DFAX circle that contribute to the Bellota Area Constraint

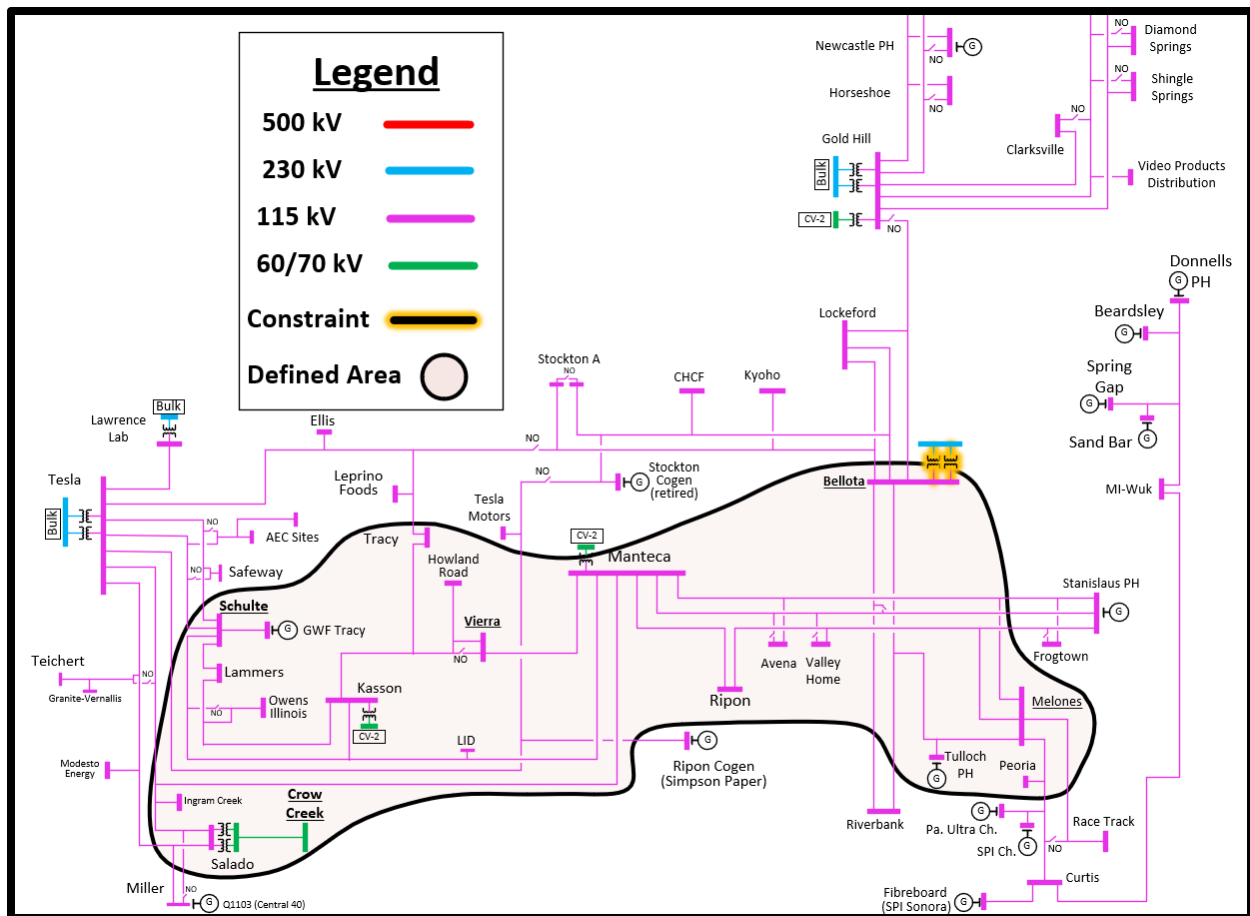

There are 0 MW of previously allocated TPD to non-operational prior commitment as described in section 2.1. The results are shown in the following table.

Table 5.5 TPD allocation for generation behind Bellota area constraint⁵

	Interconnection Service Capacity (MW)	Study Amount (MW)
Non-Operational Prior Commitment (MW)	0	0
Eligible TPD Candidate (MW)	300	300
TPD Allocated (MW)	0	0
Remaining TPD Available	0	0
Total TPD (Non-Operational Prior Commitment + TPD Allocated + Remaining TPD available)	0	0

Table 5.6: Generation Projects Contributing to the Bellota area Constraint

Queue	POI
1904	Bellota 115 kV

For Projects behind this constraint that are receiving an allocation in this TPD cycle, the following TPP upgrades are required in addition to the Network Upgrades identified for the Projects in their latest report:

- None

5.2.2 Bay Area Constraint

The deliverability assessment identified the following overload:

Table 5.7: Bay Area constraint

Overloaded Facility	Contingency	Overload
Las Positas-Newark 230 kV	Contra Costa-Moraga Nos. 1 & 2 230 kV lines	128%
Contra Costa-Delta Pump (Windmaster-Delta Pump) 230 kV line	Contra Costa-Moraga Nos. 1 & 2 230 kV lines	134%
Lone Tree-Cayetano 230 kV	Base Case	102%
CoCo-Windmaster 230 kV	Contra Costa-Moraga Nos. 1 & 2 230 kV lines	131%
Vineyard-Newark 230 kV	Base Case	103%

⁵ This area constraint has multiple overloads. Numbers provided in the table are based on the most representative constraint.

Table 5.8 TPD allocation for generation behind Bay Area constraint

	Interconnection Service Capacity (MW)	Study Amount (MW)
Non-Operational Prior Commitment (MW)	267	227
Eligible TPD Candidate (MW)	1850	1850
TPD Allocated (MW)	1164	1164
Remaining TPD Available	0	0
Total TPD (Non-Operational Prior Commitment + TPD Allocated + Remaining TPD available)	1431	1392

Table 5.9: Generation Projects Contributing to the Bay Area Constraint

Queue	POI
1850	Birds Landing 230 kV
1854	Vaca-Dixon 230 kV
1843	Lambie 230 kV
1915	Contra Costa PP 230 kV
1892	Contra Costa PP 230 kV
1842	Lambie 230 kV
1463	Birds Landing 230 kV
1461	Kelso-Tesla Tap 230 kV
1363	Delta Switching Yard-Tesla 230 kV Line

For Projects behind this constraint that are receiving an allocation in this TPD cycle, the following TPP upgrades are required in addition to the Network Upgrades identified for the Projects in their latest report:

- None

5.2.3 Tesla-Westley 230kV Area Constraint

The deliverability assessment identified the following overloads:

Table 5.10: Tesla-Westley 230KV Area Constraint

Overloaded Facility	Contingency	Overload
Tesla -Westley 230 kV	TESLA D 500/230kV TB 2	106%
Westley-Fink 230 kV	METCALF-MANNING 500kV	165%
Proxima- Fink 230 kV	Base Case	122%

This constraint limits deliverability of generators in the Fresno. The following figure illustrates approximate electrical boundary of the 5% DFAX circle for the constraint.

Figure 5.4: Approximate electrical boundary of the projects within the 5% DFAX circle that contribute to the Tesla-Westley 230KV Area Constraint

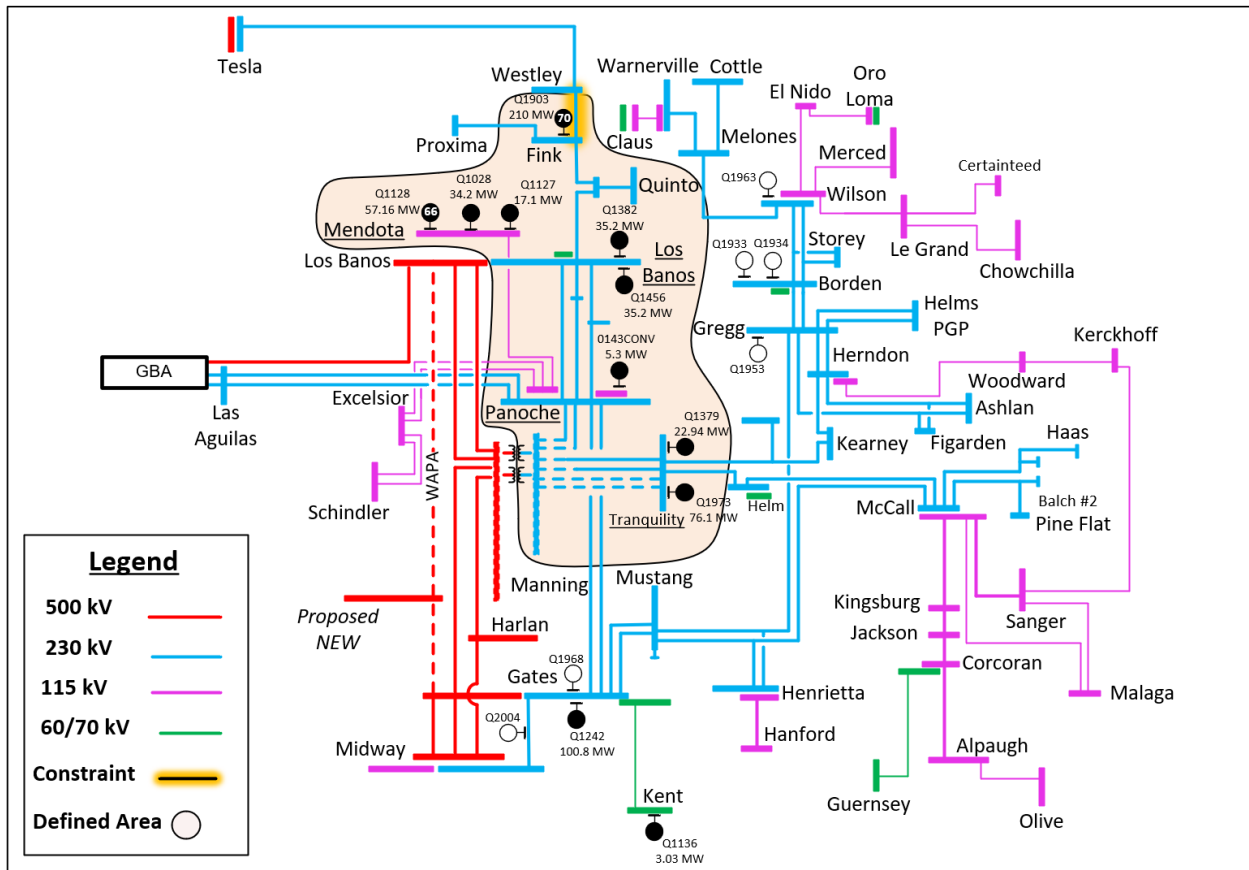

TPD was allocated to the TPD candidates after first preserving for the non-operational prior commitment as described in section 2.1. The results are shown in the following table.

The results are shown in the following table.

Table 5.11 TPD allocation for generation behind the Tesla-Westley 230 kV Area constraint

	Interconnection Service Capacity (MW)	Study Amount (MW)
Non-Operational Prior Commitment (MW)	1107	885
Eligible TPD Candidate (MW)	400	370
TPD Allocated (MW)	310	280
Remaining TPD Available	0	0
Total TPD (Non-Operational Prior Commitment + TPD Allocated + Remaining TPD available)	1417	1166

Table 5.12: Generation Projects Contributing to the Tesla-Westley 230 kV Area Constraint

Queue	POI
1903	Westly-Quinto 230 kV
1382	Los Banos 230 kV
1456	Los Banos 230 kV
1952	Los Banos 230 kV
1958	Quinto 230 kV
1728	Mercy Springs 70 kV
1718	Los Banos 70 kV
2142-WD	ORTIGA SUB
1456	Los Banos 230 kV
1382	Los Banos 230 kV
1378	Los Banos 70 kV
779	Los Banos-Panoche #1 230kV Line

For Projects behind this constraint that are receiving an allocation in this TPD cycle, the following TPP upgrades are required in addition to the Network Upgrades identified for the Projects in their latest report:

- None

5.2.4 Vaca – Contra Costa Area Constraint

The deliverability assessment identified the following overloads:

Table 5.13: Vaca-Contra Costa 230 kV Area Constraint

Overloaded Facility	Contingency	Overload
Birds Landing-Contra Costa PP 230 kV Line	Birds Landing Swt-Contra Costa Sub 230kV	119%
Lambie-Vaca Dixon 230 kV Line	Birds Landing-CC Sub 230kV Line & Birds Landing-Contra Costa PP 230kV Line	122%
Lambie-Birds Landing 230 kV Line	Vaca-Lambie 230 kV Line	122%
Birds Landing- CC Sub 230kV Line	Birds Landing Swt-Contra Costa PP 230kV	117%

This constraint limits deliverability of generators in the Greater Bay Area and North of Greater Bay Area. The following figure illustrates approximate electrical boundary of the 5% DFAX circle for the constraint.

Figure 5.5: Approximate electrical boundary of the projects within the 5% DFAX circle that contribute to the Vaca-Contra Costa 230 kV Area Constraint

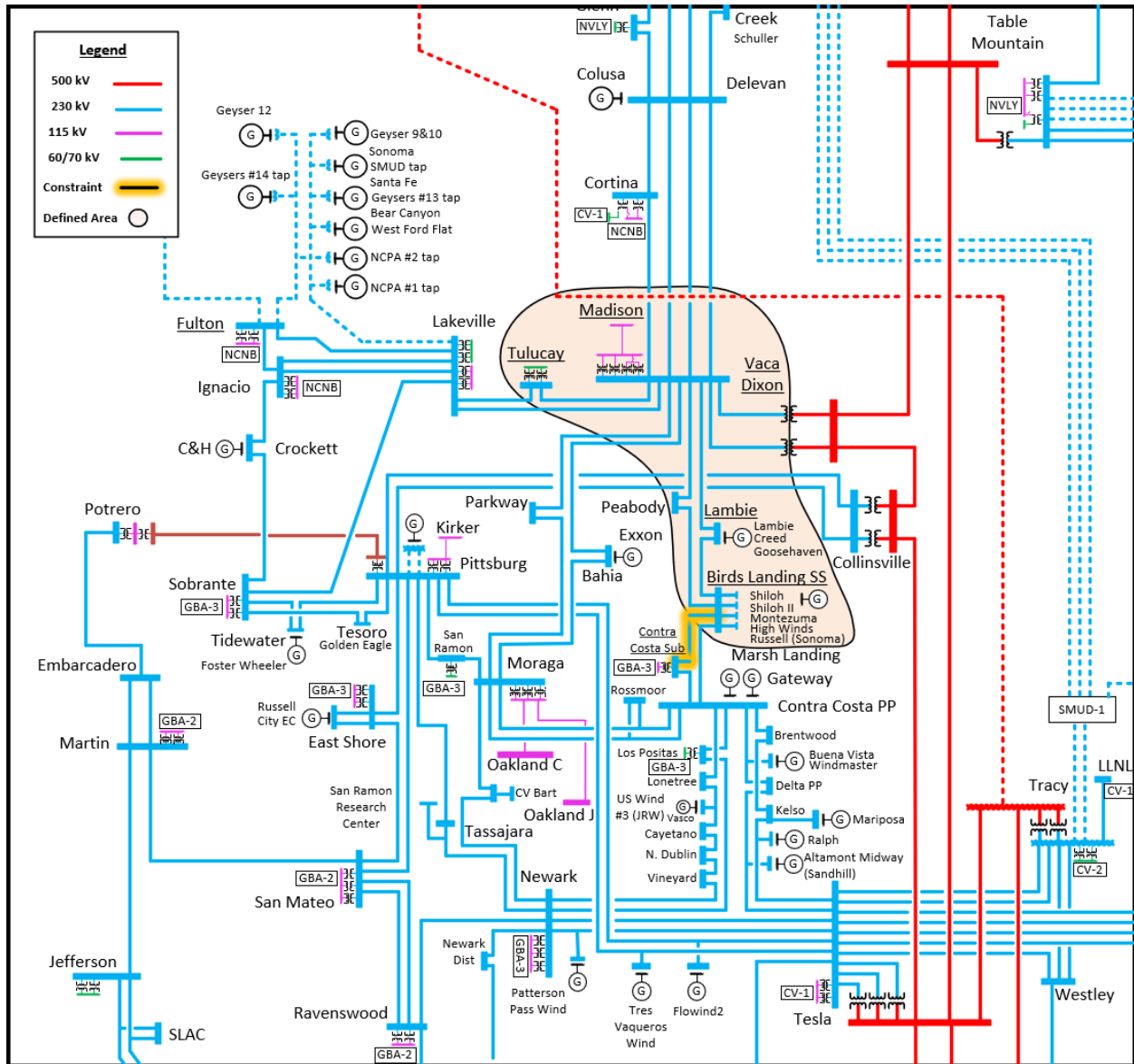

TPD was allocated to the TPD candidates after first preserving for the non-operational prior commitment as described in section 2.1. The results are shown in the following table.

Table 5.14 TPD allocation for generation behind the Vaca-Contra Costa 230 kV area constraint⁶

	Interconnection Service Capacity (MW)	Study Amount (MW)
Non-Operational Prior Commitment (MW)	835	646

⁶ This area constraint has multiple overloads. Numbers provided in the table are based on the most representative constraint.

Eligible TPD Candidate (MW)	1424	1424
TPD Allocated (MW)	924	924
Remaining TPD Available	0	0
Total TPD (Non-Operational Prior Commitment + TPD Allocated + Remaining TPD available)	1759	1570

Table 5.15: Generation Projects Contributing to the Vaca-Contra Costa 230 kV area Constraint

Queue	POI
1850	Birds Landing 230 kV
1854	Vaca-Dixon 230 kV
1843	Lambie 230 kV
2762-WD	TULUCAY SUB
1856	Vaca-Dixon 115 kV
1842	Lambie 230 kV
0141CONV	Vaca-Dixon 115 kV
2595-WD	MADISON SUB
1859	Geysers #3-Cloverdale 115 kV Line
2390-WD	MENDOCINO SUB
1565	Tulucay 60 kV
1463	Birds Landing 230 kV
1455	Cortina 60 kV
1444	Cortina 115 kV
1270	Vaca-Dixon 230 kV
2909-WD	EAGLE ROCK SUB

For Projects behind this constraint that are receiving an allocation in this TPD cycle, the following TPP upgrades are required in addition to the Network Upgrades identified for the Projects in their latest report:

- None

5.2.5 Lockeford 230 kV Area Constraint

The deliverability assessment identified the following overloads:

Table 5.14: Lockeford 230 kV Area Constraint

Overloaded Facility	Contingency	Overload
Lockeford-Bellota 230 kV Line #1	LOCKEFORD-BELLOTA #2 230kV	111%
Lockeford Jct 2-Bellota 230 kV Line #1	LOCKEFORD-BELLOTA #1 230kV	111%

This constraint limits deliverability of generators in the Greater Bay Area and North of Greater Bay Area. The following figure illustrates approximate electrical boundary of the 5% DFAX circle for the constraint.

Figure 5.5: Approximate electrical boundary of the projects within the 5% DFAX circle that contribute to the Lockeford 230 kV Area Constraint

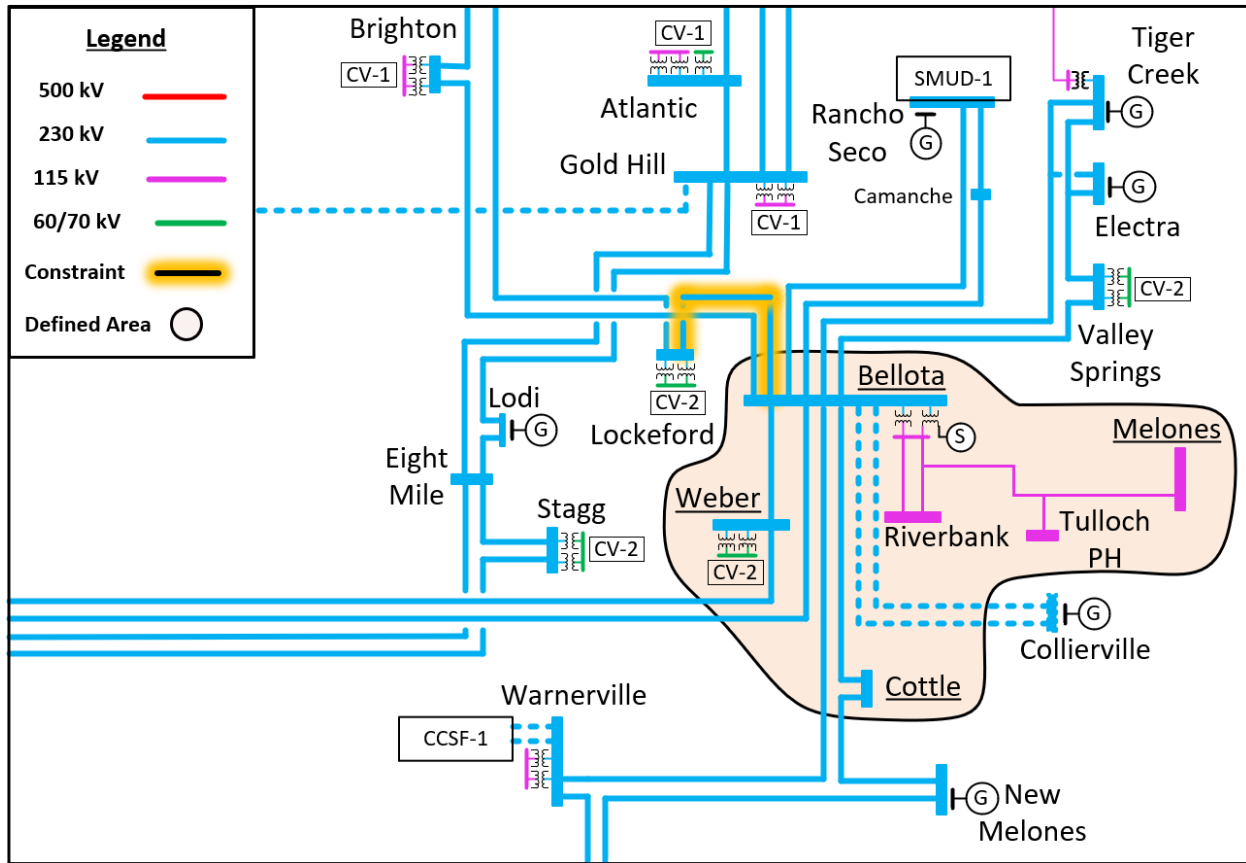

TPD was allocated to the TPD candidates after first preserving for the non-operational prior commitment as described in section 2.1. The results are shown in the following table.

Table 5.15 TPD allocation for generation behind the Lockeford 230 kV area constraint⁷

	Interconnection Service Capacity (MW)	Study Amount (MW)
Non-Operational Prior Commitment (MW)	711	710
Eligible TPD Candidate (MW)	400	400
TPD Allocated (MW)	49	49
Remaining TPD Available	0	0

⁷ This area constraint has multiple overloads. Numbers provided in the table are based on the most representative constraint.

Total TPD (Non-Operational Prior Commitment + TPD Allocated + Remaining TPD available)	760	759
----------------------------------------------------------------------------------------	-----	-----

Table 5.16: Generation Projects Contributing to the Lockeford 230 kV area Constraint

Queue	POI
1904	Bellota 115 kV
1895	Cottle 230 kV
1896	Weber 60 kV
1876	Valley Springs 60 kV
1887	Rancho Seco-Bellota #1 230 kV Line

For Projects behind this constraint that are receiving an allocation in this TPD cycle, the following TPP upgrades are required in addition to the Network Upgrades identified for the Projects in their latest report:

- None

5.2.6 Banta 115 kV Area Constraint

The deliverability assessment identified the following overloads:

Table 5.17: Banta 115 kV Area Constraint

Overloaded Facility	Contingency	Overload
Banta-Heinz 115 kV line	TESLA-SCHULTE SW STA #2 115KV & TESLA-SCHULTE SW STA #1 115KV	150%
Kasson- Banta 115 kV Line	TESLA-SCHULTE SW STA #2 115KV & TESLA-SCHULTE SW STA #1 115KV	108%
Safeway- AEC 115 kV Line	Tesla- Schulte #1 115 kV line	101%
Tracy- Heinz 115 kV	TESLA-SCHULTE SW STA #2 115KV & TESLA-SCHULTE SW STA #1 115KV	147%

This constraint limits deliverability of generators in the Greater Bay Area and North of Greater Bay Area. The following figure illustrates approximate electrical boundary of the 5% DFAX circle for the constraint.

Figure 5.5: Approximate electrical boundary of the projects within the 5% DFAX circle that contribute to the Banta 115 kV Area Constraint

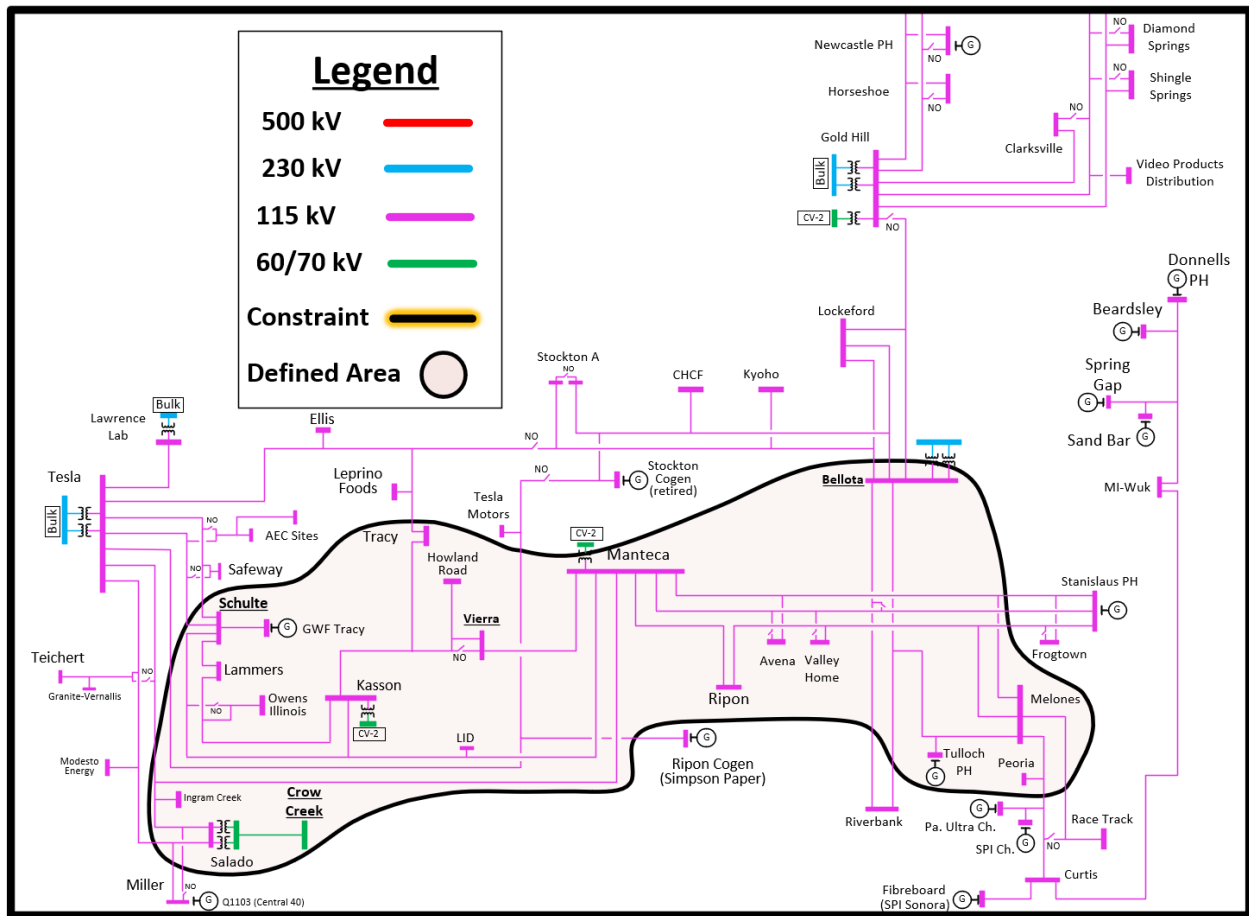

TPD was allocated to the TPD candidates after first preserving for the non-operational prior commitment as described in section 2.1. The results are shown in the following table.

Table 5.18 TPD allocation for generation behind the Banta 115 kV area constraint⁸

	Interconnection Service Capacity (MW)	Study Amount (MW)
Non-Operational Prior Commitment (MW)	204	204
Eligible TPD Candidate (MW)	494	495
TPD Allocated (MW)	14	14

⁸ This area constraint has multiple overloads. Numbers provided in the table are based on the most representative constraint.

Remaining TPD Available	0	0
Total TPD (Non-Operational Prior Commitment + TPD Allocated + Remaining TPD available)	218	218

Table 5.19: Generation Projects Contributing to the Banta 115 kV area Constraint

Queue	POI
1904	Bellota 115 kV
1920	Schulte 115 kV
1690	Vierra 115 kV
1920	Schulte 115 kV
1690	Vierra 115 kV
1557	Ripon 115 kV

For Projects behind this constraint that are receiving an allocation in this TPD cycle, the following TPP upgrades are required in addition to the Network Upgrades identified for the Projects in their latest report:

- None

5.2.7 Tesla 115 kV Area Constraint

The deliverability assessment identified the following overloads:

Table 5.20: Tesla 115 kV Area Constraint

Overloaded Facility	Contingency	Overload
Tesla-AEC #1 115 kV line	Tesla- Schulte #1 115 kV line	128%
Tesla-AEC #2 115 kV line	Tesla- Schulte #2 115 kV line	127%
Safeway- Schulte 115 kV Line	Tesla- Schulte #1 115 kV line	101%

This constraint limits deliverability of generators in the Greater Bay Area and North of Greater Bay Area. The following figure illustrates approximate electrical boundary of the 5% DFAX circle for the constraint.

Figure 5.5: Approximate electrical boundary of the projects within the 5% DFAX circle that contribute to the Tesla 115 kV Area Constraint

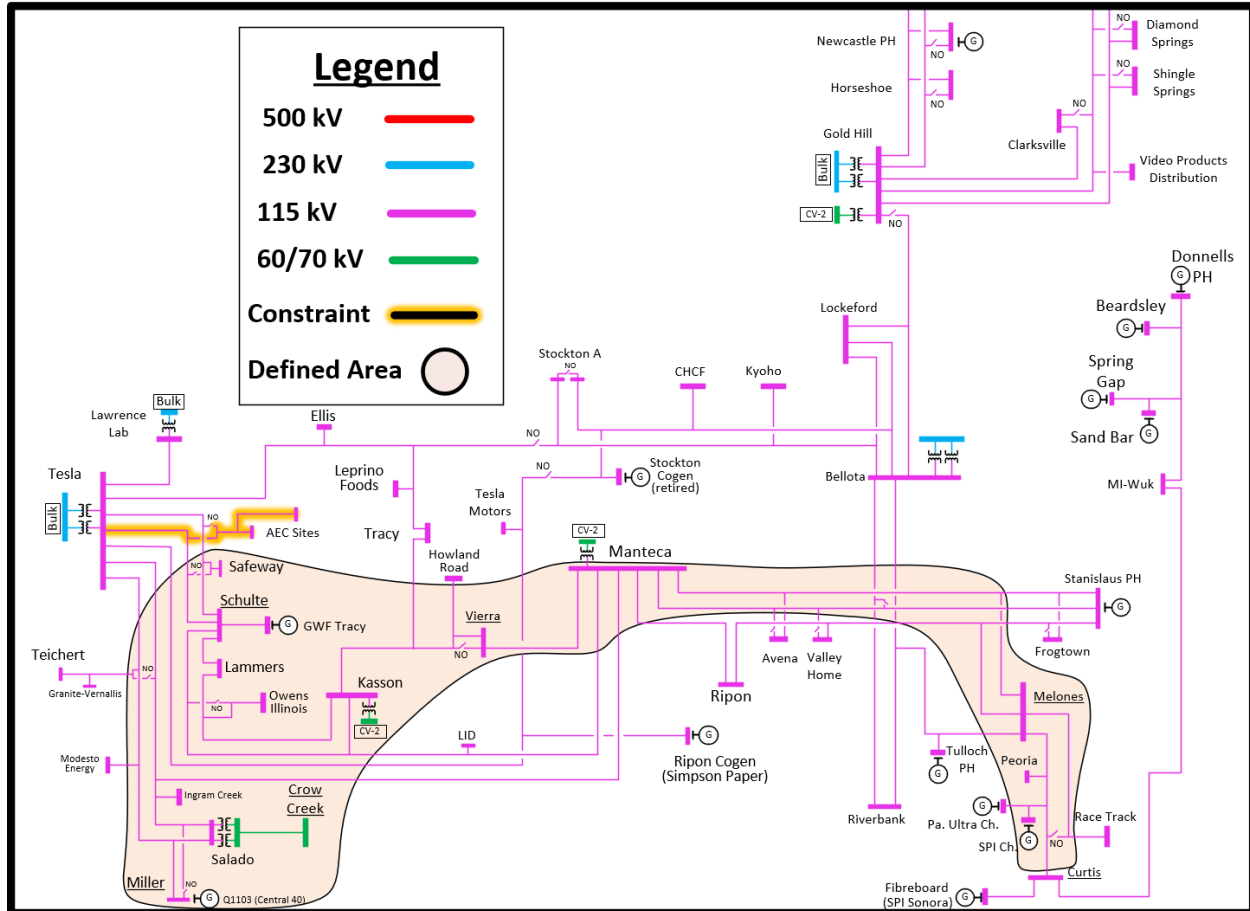

TPD was allocated to the TPD candidates after first preserving for the non-operational prior commitment as described in section 2.1. The results are shown in the following table.

Table 5.21 TPD allocation for generation behind the Tesla 115 kV area constraint⁹

	Interconnection Service Capacity (MW)	Study Amount (MW)
Non-Operational Prior Commitment (MW)	204	204
Eligible TPD Candidate (MW)	194	194
TPD Allocated (MW)	14	14
Remaining TPD Available	0	0
Total TPD (Non-Operational Prior Commitment + TPD Allocated + Remaining TPD available)	218	218

⁹ This area constraint has multiple overloads. Numbers provided in the table are based on the most representative constraint.

Table 5.22: Generation Projects Contributing to the Tesla 115 kV area Constraint

Queue	POI
1920	Schulte 115 kV
1690	Vierra 115 kV
1920	Schulte 115 kV
1690	Vierra 115 kV
1557	Ripon 115 kV

For Projects behind this constraint that are receiving an allocation in this TPD cycle, the following TPP upgrades are required in addition to the Network Upgrades identified for the Projects in their latest report:

- None

5.3 Fresno Interconnection Area Constraints

5.3.1 Gates 500/230 kV Transformer Area Constraint

The deliverability assessment identified the following overload:

Table 5.13: Gates 500/230 kV Transformer Area Constraint

Overloaded Facility	Contingency	Overload
Gates 500/230 kV Transformer #11	GATES 500/230kV TB 12	121%
Gates 500/230 kV Transformer #12	GATES 500/230kV TB 11	118%

This constraint limits deliverability of generators in the Fresno Area and Kern Area. The following figure illustrates approximate electrical boundary of the 5% DFAX circle for the constraint.

Table 5.25 TPD allocation for generation behind Gates 500/230 kV Bank area constraint

	Interconnection Service Capacity (MW)	Study Amount (MW)
Non-Operational Prior Commitment (MW)	5123	4123
Eligible TPD Candidate (MW)	4908	3547
TPD Allocated (MW)	560	344
Remaining TPD Available	0	0
Total TPD (Non-Operational Prior Commitment + TPD Allocated + Remaining TPD available)	5683	4467

Table 5.26: Generation Projects Contributing to the Gates 500/230 kV Bank area Constraint

Queue	POI
1953	Gregg 230 kV
2004	Gates-Midway 230 kV Line
1983	Shafter 115 kV
1968	Gates 230 kV
1973	Tranquility 230kV
2018	Arco-Carneras 70 kV Line
1963	Wilson 230 kV
1963	Wilson 230 kV
1934	Borden 230 kV
2015	Wheeler Ridge 230 kV
2015	Wheeler Ridge 230 kV
2850-WD	CABRILLO SUB
1379	Tranquility 230 kV
1260	Midway-Wheeler Ridge #2 230 kV Line
1933	Borden 230 kV
1744	Lamont 115 kV
1394	Midway 115 kV
1959	Gates-Templeton 230 kV Line
1994	Lamont 115 kV
1995	Kern PP 230 kV
1587	Arco 230 kV
1242	Gates 230 kV
1128	Mendota Substation 115kV
1127	Mendota Substation 115kV
946	Midway-Wheeler Ridge #2 230 kV Line
0143CONV	Panoche 115 kV
2596-WD	DOS PALOS SUB
2764-WD	FAIRWAY SUB

1935	Tranquility 230 kV
2017	Olive 115 kV
1932	Wilson 115 kV
1975	Crescent 70 kV
1954	Gates 230 kV
1955	Excelsior 115 kV
1956	Tranquility 230 kV
2001	Kern PP 230 kV
1980	Arco 230 kV
1970	Le Grand 115 kV
1966	Giffen 70 kV
1930	Sanger 115 kV
1959	Gates-Templeton 230 kV Line
2226-WD	PANOCHÉ SUB
1709	Crescent 70 kV
1728	Mercy Springs 70 kV
1736	Arco 230 kV
1751	Midway 115 kV
2142-WD	ORTIGA SUB
1593	Gates-Midway 230 kV Line
2040-WD	TAFT SUB
2105-WD	TAFT SUB
2174-WD	TAFT SUB
2175-WD	TAFT SUB
1495	Arco 230 kV
1499	Lakeview 70 kV
1443	Olive 115 kV
1391	Tranquility 230 kV
1389	Gates 230 kV
1223	Mustang 230 kV
1143	Corcoran-Olive 115 kV Line
1243	Gates 230 kV
1128	Mendota Substation 115kV
1129	Tranquility 230 kV
1493	Arco 70 kV
1129	Tranquility 230 kV
1242	Gates 230 kV
744	Lamont 115 KV
900	Midway Temblor 115 kV line
972	Midway-Temblor 115kV line
653B	Belridge - Temblor 115 kV

For projects behind this constraint that are receiving an allocation in this TPD cycle, the following TPP upgrades are required in addition to the Network Upgrades identified for the projects in their latest report:

- New Manning- Metcalf 500 kV Line

5.3.2 Gregg 230 kV Area Constraint

The deliverability assessment identified the following overloads:

Table 5.27: Gregg 230 kV Area Constraint

Overloaded Facility	Contingency	Overload
Herndon-Woodward 115 kV Line (Herndon-Children's Hospital)	HERNDON-BARTON 115KV & HERNDON-MANCHESTER 115KV	129%
Gregg- Herndon # 1 230 kV line	Gregg- Herndon # 2 230 kV line	112%
Gregg- Herndon # 2 230 kV line	Gregg- Herndon # 1 230 kV line	112%
Le Grand – Certainteed 115kV line	Helm-McCall 230kV line & McCall-Mustang #1 230 kV line	129%
Children's Hospital- Woodward 115 kV Line	Herndon- Barton 115kV line and Herndon-Manchester 115kV line	126%

This constraint limits deliverability of generators in the Fresno Area. The following figure illustrates approximate electrical boundary of the 5% DFAX circle for the constraint.

Figure 5.7: Approximate electrical boundary of the projects within the 5% DFAX circle that contribute to the Gregg 230 kV Area Constraint

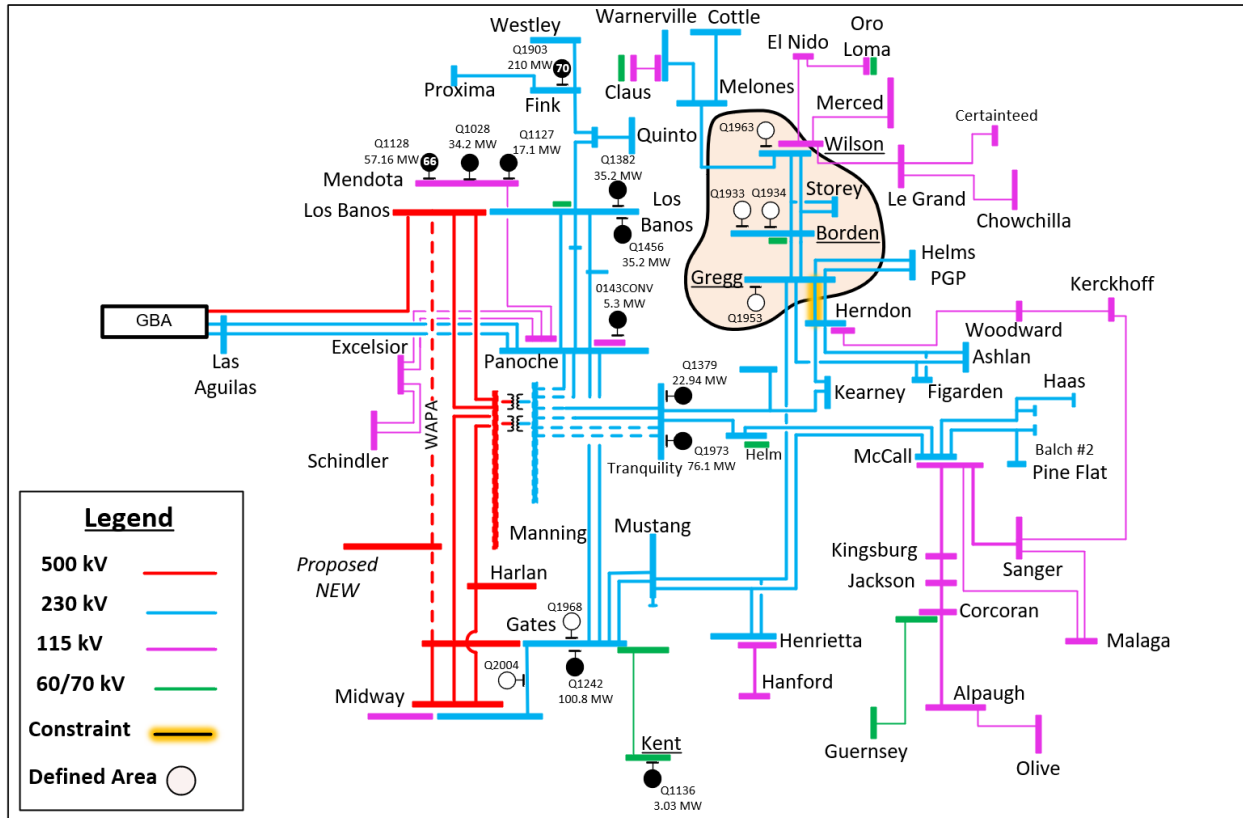

There are 0 MW of previously allocated TPD to non-operational prior commitment as described in section 2.1. The results are shown in the following table.

Table 5.28 TPD Allocation for Generation behind the Gregg 230 kV Area Constraint¹⁰

	Interconnection Service Capacity (MW)	Study Amount (MW)
Non-Operational Prior Commitment (MW)	0	0
Eligible TPD Candidate (MW)	800	800
TPD Allocated (MW)	0	0
Remaining TPD Available	0	0
Total TPD (Non-Operational Prior Commitment + TPD Allocated + Remaining TPD available)	0	0

¹⁰ This area constraint has multiple overloads. Numbers provided in the table are based on the most representative constraint.

Table 5.29: Generation Projects Contributing to the Gregg 230 kV Constraint

Queue	POI
1128	Mendota 115 kV
1953	Gregg 230 kV
1963	Wilson 230 kV
1934	Borden 230 kV
1933	Borden 230 kV

For Projects behind this constraint that are receiving an allocation in this TPD cycle, the following TPP upgrades are required in addition to the Network Upgrades identified for the Projects in their latest report:

- None

5.3.3 Cottle 230 kV Area Constraint

The deliverability assessment identified the following overload:

Table 5.30: Cottle 230 kV Area Constraint

Overloaded Facility	Contingency	Overload
Cottle-Melones 230 kV Line	Base Case	136%
Melones- Wilson 230 kV line	Bellota- Cottle 230kV line and Bellota- Warnerville 230kV line	114%
Warnerville- Wilson 230 kV line	Cottle-Melones 230 kV Line	109%

This constraint limits deliverability of generators in the Fresno Area. The following figure illustrates approximate electrical boundary of the 5% DFAX circle for the constraint.

Figure 5.9: Approximate electrical boundary of the projects within the 5% DFAX circle that contribute to the Cottle 230 kV Area Constraint

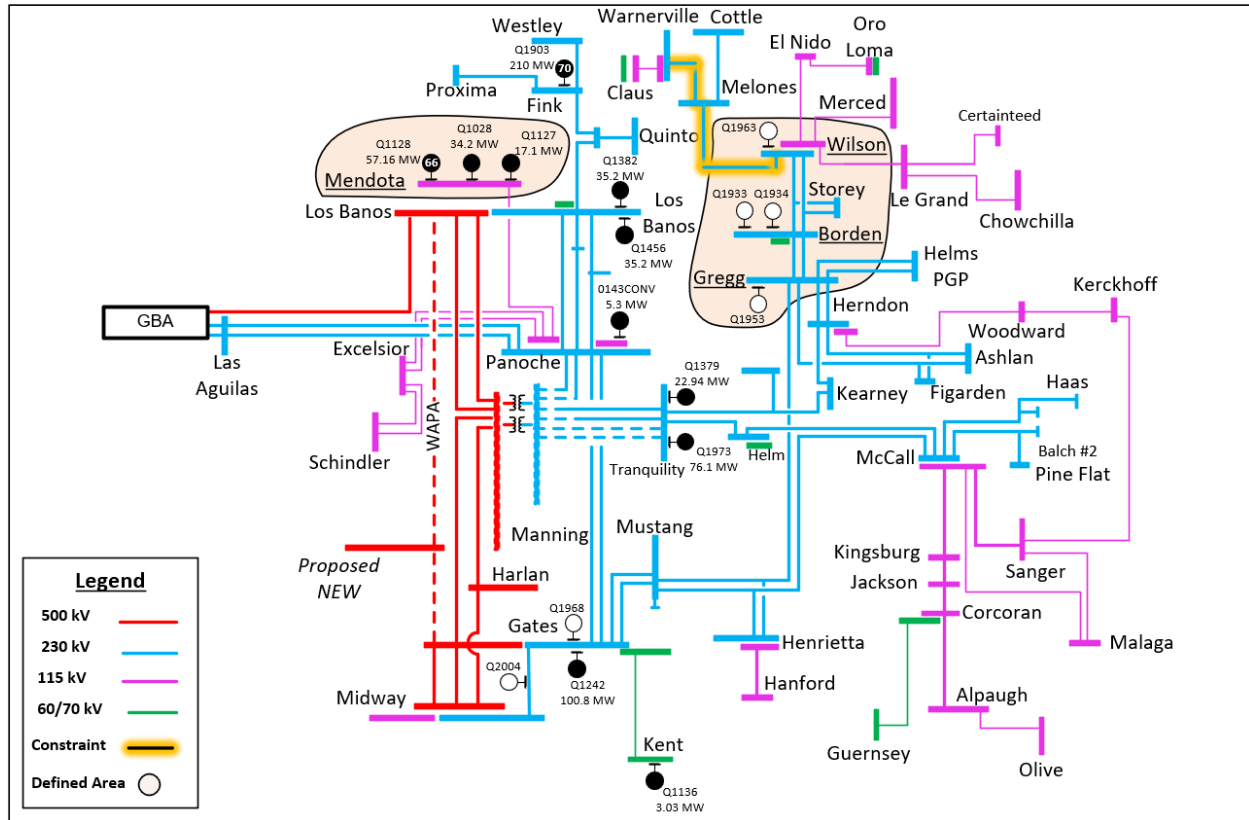

TPD was allocated to the TPD candidates after first preserving for the non-operational prior commitment as described in section 2.1. The results are shown in the following table.

The results are shown in the following table.

Table 5.31 TPD Allocation for Generation behind the Cottle 230 kV Area Constraint

	Interconnection Service Capacity (MW)	Study Amount (MW)
Non-Operational Prior Commitment (MW)	530	485
Eligible TPD Candidate (MW)	800	800
TPD Allocated (MW)	0	0
Remaining TPD Available	0	0
Total TPD (Non-Operational Prior Commitment + TPD Allocated + Remaining TPD available)	530	485

Table 5.32: Generation Projects Contributing to the Cottle 230 kV Area Constraint

Queue	POI
1933	Borden 230 kV
1934	Borden 230 kV
1953	Gregg 230 kV
1959	Gates-Templeton 230 kV Line
1963	Wilson 230 kV
723	Borden 70kV

For Projects behind this constraint that are receiving an allocation in this TPD cycle, the following TPP upgrades are required in addition to the Network Upgrades identified for the Projects in their latest report:

- None

5.3.4 Mustang- Henrietta 230 kV Area Constraint

The deliverability assessment identified the following overloads:

Table 5.33: Mustang- Henrietta Area Constraint

Overloaded Facility	Contingency	Overload
Mustang – Henrietta tap 1 230kV	Helm- McCall 230kV and McCall-Mustang 230 kV	107%
Mustang – Henrietta tap 2 230kV	Mustang- Gregg 230kV and Tranquility-Kearney 230 kV	109%

This constraint limits deliverability of generators in the Fresno Area. The following figure illustrates approximate electrical boundary of the 5% DFAX circle for the constraint.

Figure 5.11: Approximate electrical boundary of the projects within the 5% DFAX circle that contribute to the Mustang- Henrietta Area Constraint

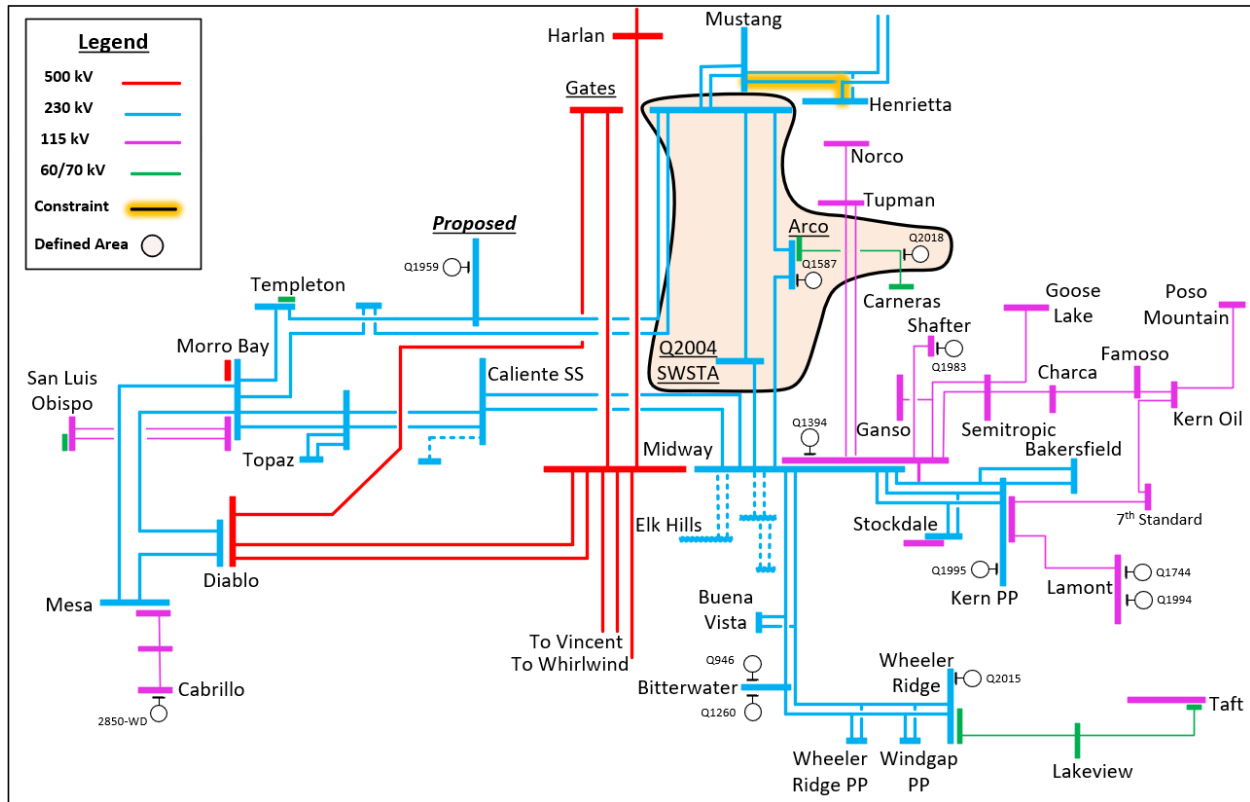

TPD was allocated to the TPD candidates after first preserving for the non-operational prior commitment as described in section 2.1. The results are shown in the following table.

The results are shown in the following table.

Table 5.34 TPD Allocation for Generation behind the Mustang- Henrietta 230 kV Area Constraint¹¹

	Interconnection Service Capacity (MW)	Study Amount (MW)
Non-Operational Prior Commitment (MW)	5648	4531
Eligible TPD Candidate (MW)	530	530
TPD Allocated (MW)	0	0
Remaining TPD Available	0	0
Total TPD (Non-Operational Prior Commitment + TPD Allocated + Remaining TPD available)	5648	4531

¹¹ This area constraint has multiple overloads. Numbers provided in the table are based on the most representative constraint.

Table 5.35: Generation Projects Contributing to the Mustang- Henrietta 230 kV area Constraint

Queue	POI
2004	Gates-Midway 230 kV Line
2018	Arco-Carneras 70 kV Line
1587	Arco 230 kV
1954	Gates 230 kV
1980	Arco 230 kV
1736	Arco 230 kV
1593	Gates-Midway 230 kV Line
1495	Arco 230 kV
1389	Gates 230 kV
1223	Mustang 230 kV
1493	Arco 70 kV

For Projects behind this constraint that are receiving an allocation in this TPD cycle, the following TPP upgrades are required in addition to the Network Upgrades identified for the Projects in their latest report:

- None

5.4 Kern Interconnection Area Constraints

5.4.1 Midway- Harlan 500 kV Area Constraint

The deliverability assessment identified the following overload:

Table 5.36: Midway- Harlan 500 kV Area Constraint

Overloaded Facility	Contingency	Overload
Midway- Harlan 500 kV line	Manning-Gates 500 kV line	139%
Harlan- Manning 500 kV Line	Base Case	145%

This constraint limits deliverability of generators in the Kern Area. The following figure illustrates approximate electrical boundary of the 5% DFAX circle for the constraint.

Figure 5.13: Approximate electrical boundary of the projects within the 5% DFAX circle that contribute to the Midway- Harlan 500 kV Area Constraint

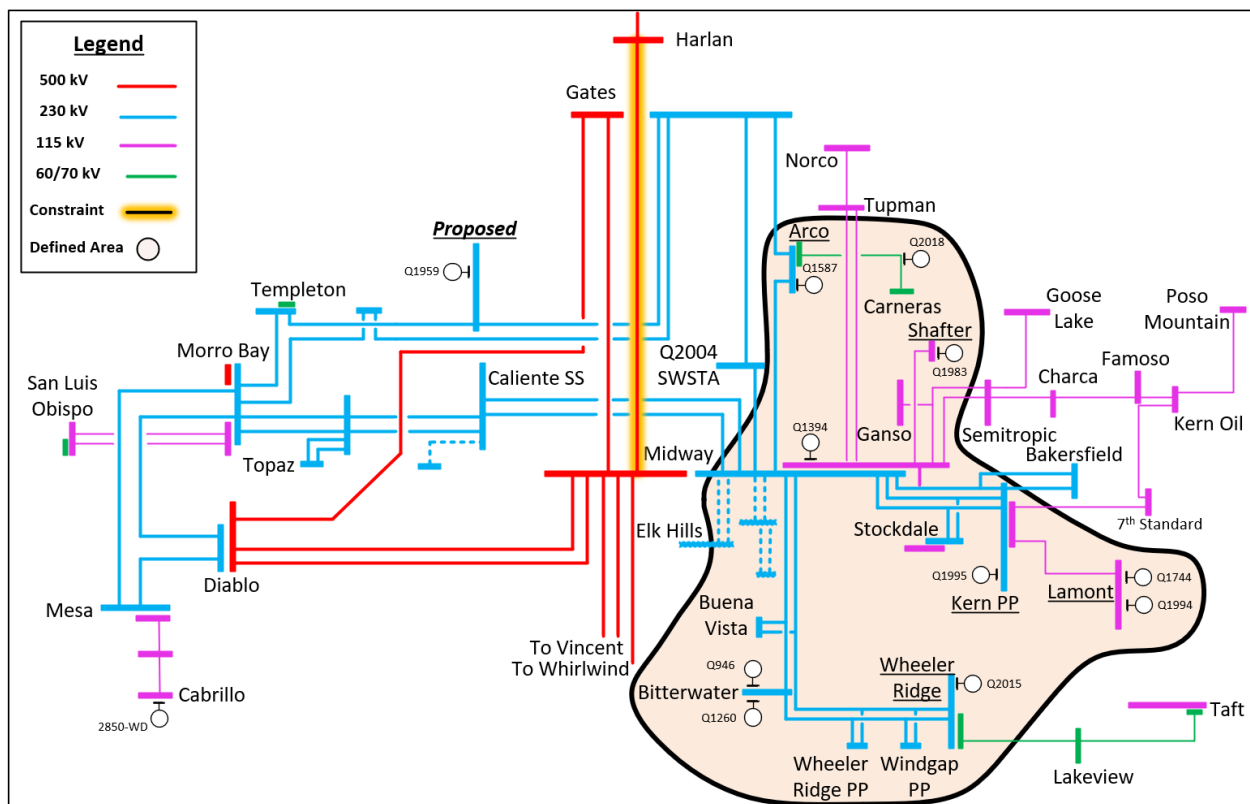

TPD was allocated to the TPD candidates after first preserving for the non-operational prior commitment as described in section 2.1. The results are shown in the following table.

Table 5.37 TPD allocation for generation behind the Midway- Harlan 500 kV Area Constraint

	Interconnection Service Capacity (MW)	Study Amount (MW)
Non-Operational Prior Commitment (MW)	6907	5955
Eligible TPD Candidate (MW)	1998	1483
TPD Allocated (MW)	0	0
Remaining TPD Available	0	0
Total TPD (Non-Operational Prior Commitment + TPD Allocated + Remaining TPD available)	6907	5955

Table 5.38: Generation Projects Contributing to the Midway- Harlan 500 kV Area Constraint

Queue	POI
2004	Gates-Midway 230 kV Line
1983	Shafter 115 kV
2018	Arco-Carneras 70 kV Line
2015	Wheeler Ridge 230 kV
2015	Wheeler Ridge 230 kV
2850-WD	CABRILLO SUB
1260	Midway-Wheeler Ridge #2 230 kV Line
1744	Lamont 115 kV
1394	Midway 115 kV
1994	Lamont 115 kV
1995	Kern PP 230 kV
1587	Arco 230 kV
946	Midway-Wheeler Ridge #2 230 kV Line
2764-WD	FAIRWAY SUB
2017	Olive 115 kV
1987	Midway 500 kV
1962	Gates 500 kV
2001	Kern PP 230 kV

1980	Arco 230 kV
1750	Diablo Canyon 500 kV
1736	Arco 230 kV
1751	Midway 115 kV
1596	Midway 500 kV
1593	Gates-Midway 230 kV Line
2040-WD	TAFT SUB
2105-WD	TAFT SUB
2174-WD	TAFT SUB
2175-WD	TAFT SUB
1479	Gates 500 kV
1495	Arco 230 kV
1499	Lakeview 70 kV
1443	Olive 115 kV
1143	Corcoran-Olive 115 kV Line
1493	Arco 70 kV
744	Lamont 115 KV
0	Diablo Canyon 500 kV
900	Midway Temblor 115 kV line
972	Midway-Temblor 115kV line
653B	Belridge - Temblor 115 kV

For Projects behind this constraint that are receiving an allocation in this TPD cycle, the following TPP upgrades are required in addition to the Network Upgrades identified for the Projects in their latest report:

- None

5.4.2 Gates-Arco-Midway 230 kV Area Constraint

The deliverability assessment identified the following overload:

Table 5.39: Gates-Arco-Midway 230 kV Area Constraint

Overloaded Facility	Contingency	Overload
Gates- Arco 230kV line	Gates – Q2004 SWT 230 kV Line	180%
Arco- Midway 230kV line	Gates 500/230 kV TB #12	121%
Q2004-Q1593 230 kV line	Gates – Q2004 SWT 230 kV Line	116%
Q1593- Midway 230 kV line	Gates – Q2004 SWT 230 kV Line	185%

This constraint limits deliverability of generators in the Kern Area. The following figure illustrates approximate electrical boundary of the 5% DFAX circle for the constraint.

Figure 5.14: Approximate electrical boundary of the projects within the 5% DFAX circle that contribute to the Gates-Arco-Midway 230 kV Area Constraint

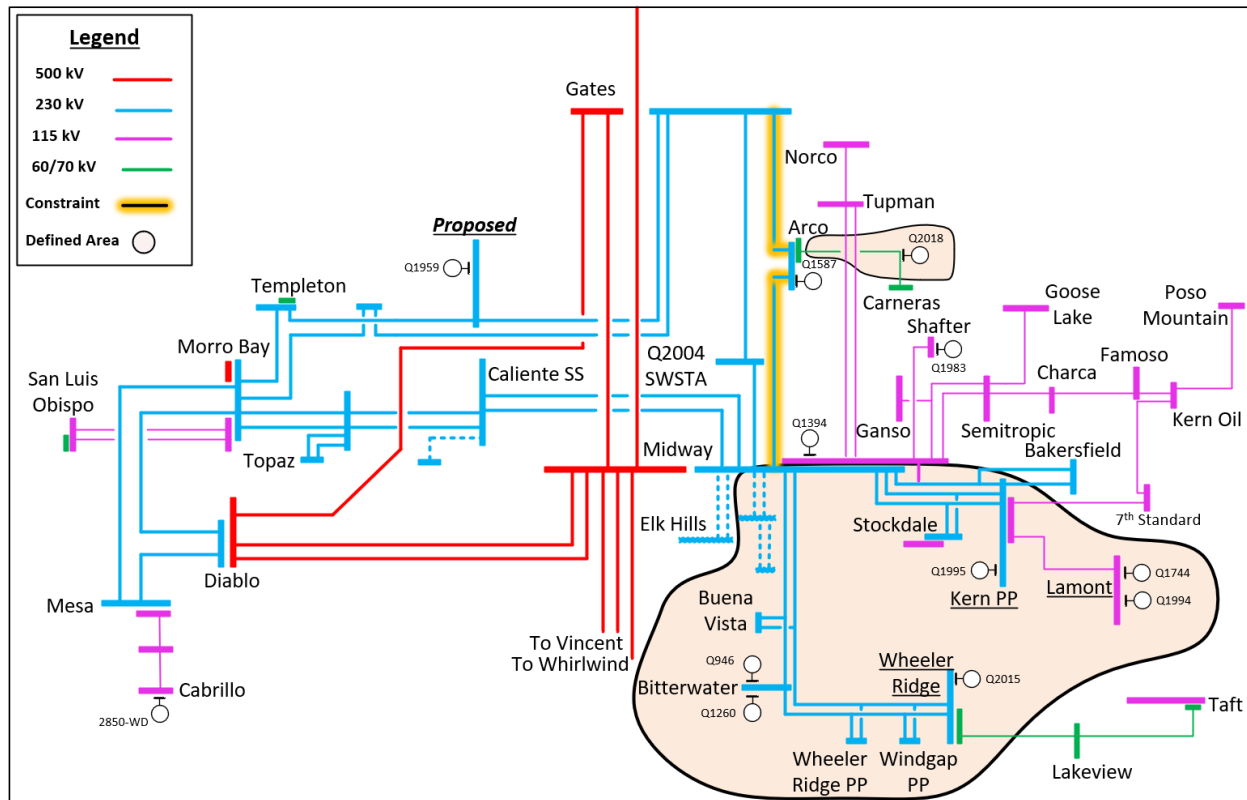

TPD was allocated to the TPD candidates after first preserving for the non-operational prior commitment as described in section 2.1. The results are shown in the following table.

Table 5.40 TPD Allocation for Generation behind the Gates-Arco-Midway 230 kV Area Constraint¹²

	Interconnection Service Capacity (MW)	Study Amount (MW)
Non-Operational Prior Commitment (MW)	2023	1568
Eligible TPD Candidate (MW)	1938	1432
TPD Allocated (MW)	0	0
Remaining TPD Available	0	0
Total TPD (Non-Operational Prior Commitment + TPD Allocated + Remaining TPD available)	2023	1569

Table 5.41: Generation Projects Contributing to the Gates- Arco-Midway 230 kV Area Constraint

Queue	POI
1394	Midway 115 kV
1587	Arco 230 kV
1744	Lamont 115 kV
1959	Gates – Templeton 230 kV Line
1968	Gates 230kV
1983	Shafter 115 kV
1994	Lamont 115 kV
1995	Kern PP 230 kV
2004	Gates – Midway 230 kV Line
2018	Arco-Carneras 70 kV Line

For Projects behind this constraint that are receiving an allocation in this TPD cycle, the following TPP upgrades are required in addition to the Network Upgrades identified for the Projects in their latest report:

- None

¹² This area constraint has multiple overloads. Numbers provided in the table are based on the most representative constraint.

5.4.3 Bitterwater- Buena Vista 230kV kV Area Constraint*

The deliverability assessment identified the following overload:

Table 5.32: Bitterwater-Buena Vista 230 kV Area Constraint

Overloaded Facility	Contingency	Overload
Bitterwater-Buena Vista #2 230 kV line	Midway Wheeler Ridge #1 230 kV line	197%
Wheeler Ridge- Wind gap #1 230 kV Line	Midway- Bitterwater 230 kV line	156%
Wheeler Ridge- Wind gap #2 230 kV Line	Wheeler- Casa loma 230 kV line	162%
Buena Vista 1- Midway #1 230 kV line	Midway- Bitterwater 230 kV line	157%
Buena Vista 2- Midway #1 230 kV line	Midway Wheeler Ridge #1 230 kV line	198%
Bitterwater- Buena Vista #2 230 kV line	Midway Wheeler Ridge #1 230 kV line	197%
Bitterwater- Wheeler ridge #2 230 kV line	Midway- Bitterwater # 1 230 kV line % Midway- Bitterwater #2 230 kV line	117%

This constraint limits deliverability of generators in the Kern Area. The following figure illustrates approximate electrical boundary of the 5% DFAX circle for the constraint.

Figure 5.14: Approximate electrical boundary of the projects within the 5% DFAX circle that contribute to the Bitterwater-Buena Vista 230 kV Area Constraint

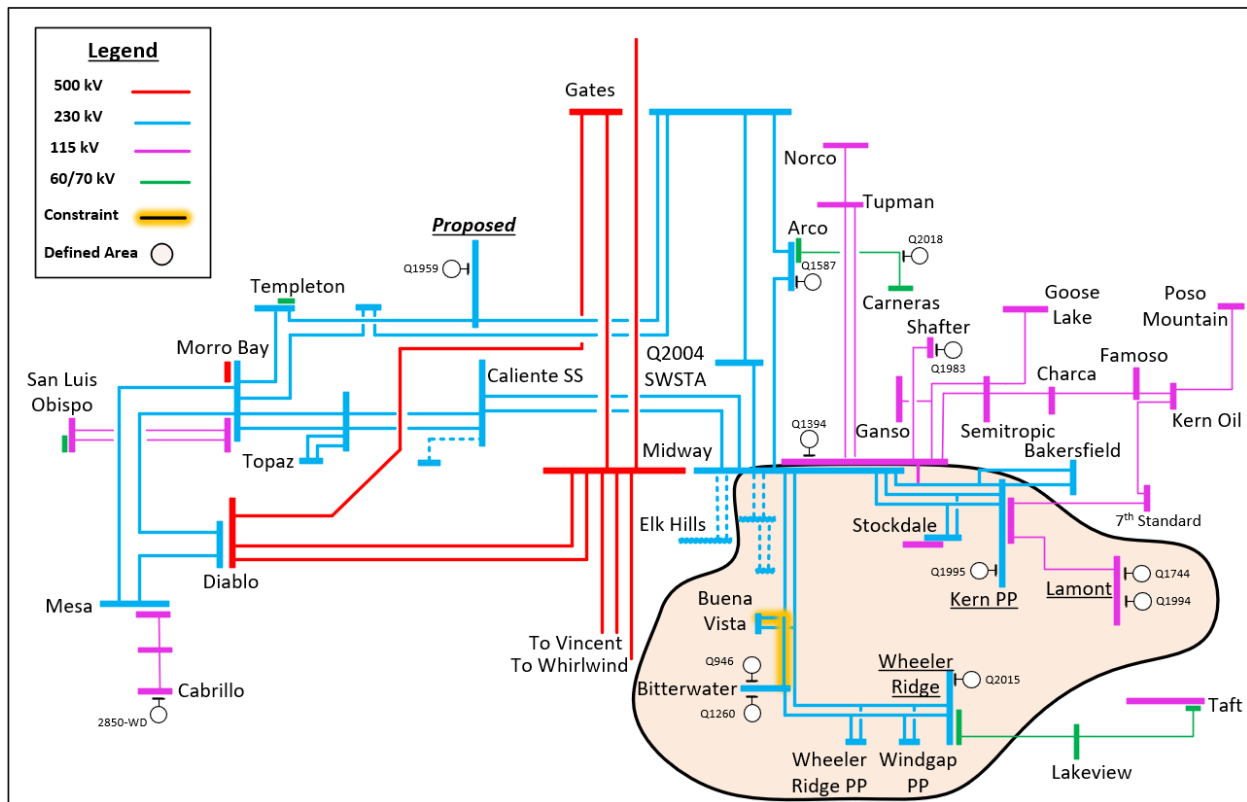

TPD was allocated to the TPD candidates after first preserving for the non-operational prior commitment as described in section 2.1. The results are shown in the following table.

Table 5.43 TPD Allocation for Generation behind the Bitterwater-Buena Vista 230 kV Area Constraint¹³

	Interconnection Service Capacity (MW)	Study Amount (MW)
Non-Operational Prior Commitment (MW)	270	187
Eligible TPD Candidate (MW)	1108	602
TPD Allocated (MW)	0	0
Remaining TPD Available	0	0
Total TPD (Non-Operational Prior Commitment + TPD Allocated + Remaining TPD available)	270	187

Table 5.44: Generation Projects Contributing to the Bitterwater-Buena Vista 230 kV Area Constraint

Queue	POI
946	Midway-Wheeler Ridge #2 230 kV Line
1260	Midway-Wheeler Ridge #2 230 kV Line
1995*	Kern PP 230 kV
2015	Wheeler Ridge 230 kV

For Projects behind this constraint that are receiving an allocation in this TPD cycle, the following TPP upgrades are required in addition to the Network Upgrades identified for the Projects in their latest report:

- None

¹³ This area constraint has multiple overloads. Numbers provided in the table are based on the most representative constraint.

- This constraint is caused by rights preservation for CDWR

5.4.4 PG&E Area Constraint Summary

The following table provides a summary showing all of the Deliverability Constraints described above and which non-operational generation projects are impacted by those constraints.

Table 3.4-29: PG&E Area Deliverability Constraint Mapping

2025 TPD Allocation

Queue	Collinsville-Tesla 20kV Constraint	Bellota Area Constraint	/ Area Constraint	Tesla 230kV Area Constraint	Vaca - Contra Costa Area Constraint	Tesla 115kV Area Constraint	Gates 500/230kV FMR Constraint	Gregg 230kV Area Constraint	Cottle 230kV Area Constraint	Mustang - Henrietta 230kV Area Constraint	Midway - Harlan 500kV Area Constraint	Gates - Arco - Midway 230kV Area Constraint	Bitterwater - Buena Vista 230kV Area Constraint	Banta 115kV Area Constraint	Lockeford 230kV Area Constraint
0141CONV	x				x										
0143CONV							x								
1028+1029							x								
946							x				x	x	x		
1127							x								
1128							x								
1136							x								
1260							x				x	x	x		
1242							x								
1379							x								
1382				x											
1394							x				x	x			
1456				x											
1587							x			x	x	x			
1690						x								x	
1744							x				x	x	x		
1842	x		x		x										
1843	x		x		x										
1846	x														
1850	x		x		x										
1854	x		x		x										
1856	x				x										
1871	x														
1880	x														
1889															
1892	x		x												
1895															x
1903				x											
1904		x												x	x
1912															
1915	x		x												
1920						x								x	
1933							x	x	x						
1934							x	x	x						
1953							x	x	x						
1959							x		x			x			
1963							x	x	x			x			
1968							x								
1973							x								
1983							x				x	x			
1994							x				x	x	x		
1995							x					x	x		
1995* Split							x				x	x	x		
2004							x			x	x	x			
2015							x				x	x	x		
2018							x			x	x	x			
2850-WD							x				x				
2758-WD	x														
2179-WD	x														
2595-WD	x				x										
2622-WD	x														
2762-WD	x				x										
3258-WD															