

## **APPENDIX F: Detailed Policy Assessment**

**Intentionally left blank**

## Contents

|        |  |     |
|--------|--|-----|
| F.     | Policy-Driven Need Assessment.....                                   | 5   |
| F.1    | Background and Objectives.....                                       | 5   |
| F.2    | Objectives of policy-driven assessment.....                          | 6   |
| F.3    | Study methodology and components.....                                | 6   |
| F.4    | Resource Portfolios.....   | 8   |
| F.4.1  | Approved Non-CPUC Jurisdictional Integrated Resource Plans.....      | 11  |
| F.4.2  | Transmission capability estimates and utilization by portfolios..... | 11  |
| F.5    | Additional Guidance from CPUC regarding the Portfolios.....          | 12  |
| F.6    | On-Peak Deliverability Assessment.....                               | 15  |
| F.6.1  | On-peak deliverability assessment assumptions.....                   | 15  |
| F.6.2  | General On-peak deliverability assessment procedure.....             | 17  |
| F.7    | Off-Peak Deliverability assessment.....                              | 18  |
| F.7.1  | Off-peak deliverability assessment methodology.....                  | 18  |
| F.8    | PG&E North of Greater Bay Interconnection Area.....                  | 22  |
| F.8.1  | 2034 On-peak results.....  | 24  |
| F.8.2  | 2034 Off-peak results.....   | 31  |
| F.8.3  | 2039 On-peak results.....  | 31  |
| F.8.4  | Conclusion and recommendation.....                                   | 34  |
| F.9    | PG&E Greater Bay Interconnection Area.....                           | 34  |
| F.9.1  | 2034 On-peak results.....  | 37  |
| F.9.2  | 2034 Off-peak results.....   | 41  |
| F.9.3  | 2039 On-peak results.....  | 43  |
| F.9.4  | Conclusion and recommendation.....                                   | 47  |
| F.10   | PG&E Greater Fresno Interconnection Area.....                        | 47  |
| F.10.1 | 2034 On-peak results.....  | 50  |
| F.10.2 | 2034 Off-peak results.....   | 55  |
| F.10.3 | 2039 On-peak results.....  | 58  |
| F.10.4 | Conclusion and recommendation.....                                   | 60  |
| F.11   | PG&E East Kern Interconnection Area.....                             | 60  |
| F.11.1 | 2034 On-peak results.....  | 62  |
| F.11.2 | 2034 Off-peak results.....   | 63  |
| F.11.3 | 2039 On-peak results.....  | 63  |
| F.11.4 | Conclusion and recommendation.....                                   | 63  |
| F.12   | East of Pisgah area.....   | 63  |
| F.12.1 | 2034 On-peak results.....  | 65  |
| F.12.2 | 2034 Off-peak results.....   | 68  |
| F.12.3 | 2039 On-peak results.....  | 68  |
| F.12.4 | Wyoming Wind Sensitivity Study.....                                  | 72  |
| F.12.5 | Conclusion and recommendation.....                                   | 77  |
| F.13   | SCE Northern Area.....   | 79  |
| F.13.1 | 2034 On-peak results.....  | 81  |
| F.13.2 | 2034 Off-peak results.....   | 86  |
| F.13.3 | 2039 On-peak results.....  | 88  |
| F.13.4 | Conclusion and recommendation.....                                   | 90  |
| F.14   | SCE North of Lugo Area.....  | 91  |
| F.14.1 | 2034 On-peak results.....  | 93  |
| F.14.2 | 2034 Off-peak results.....   | 96  |
| F.14.3 | 2039 On-peak results.....  | 100 |

---

|        |   |     |
|--------|---|-----|
| F.14.4 | Conclusion and recommendation .....                                   | 105 |
| F.15   | SCE Metro Area.....   | 105 |
| F.15.1 | 2034 On-peak results.....   | 108 |
| F.15.2 | 2034 Off-peak results.....  | 108 |
| F.15.3 | 2039 On-peak results.....   | 108 |
| F.15.4 | Conclusion and recommendation .....                                   | 108 |
| F.16   | SCE Eastern .....   | 109 |
| F.16.1 | 2034 On-peak results.....   | 111 |
| F.16.2 | 2034 Off-peak results.....  | 112 |
| F.16.3 | 2039 On-peak results.....   | 114 |
| F.16.4 | Conclusion and recommendation .....                                   | 119 |
| F.17   | SDG&E area .....  | 120 |
| F.17.1 | 2034 On-peak results.....   | 122 |
| F.17.2 | 2034 Off-peak results.....  | 126 |
| F.17.3 | 2039 On-peak results.....   | 126 |
| F.17.4 | Conclusion and recommendation .....                                   | 132 |
| F.18   | Out-of-State Wind .....   | 133 |
| F.19   | Transmission Plan Deliverability with Approved Transmission Upgrades. | 134 |
| F.20   | Production cost model (PCM) results.....                              | 134 |

## F. Policy-Driven Need Assessment

### F.1 Background and Objectives

The overarching public policy objective for the California ISO's Policy-Driven Need Assessment is the state's mandate for meeting renewable energy and greenhouse gas (GHG) reduction targets while maintaining reliability. For the purposes of the transmission planning process, this high-level objective is comprised of two sub-objectives: first, to support Resource Adequacy (RA) deliverability status for the renewable generation and energy storage resources identified in the portfolio as requiring that status, and second, to support the economic delivery of renewable energy over the course of all hours of the year.

The more coordinated and proactive approach taken in the ISO's current annual transmission planning process is part of a larger set of interrelated and coordinated planning and resource development activities being undertaken between the state energy agencies and the ISO. The ISO, for example, relies in particular on the CPUC for its lead role in developing resource forecasts for the long-term planning horizon, with both the ISO and CEC providing input to the CPUC for those resource forecasts. The ISO also relies on the CEC for its lead role in forecasting customer load requirements and the MOU signed by the three parties in December 2022 reaffirms our respective roles and commitment to ensure we are working in concert with one another. As such, the MOU also sets the overall strategic direction for tightening linkages among resource and transmission planning activities, interconnection processes and resource procurement so the three entities are synchronized in working for the timely integration of new resources.

The CPUC issued a Decision<sup>1</sup> on February 8, 2018, which adopted the integrated resource planning (IRP) process designed to ensure that the electric sector is on track to help the State achieve its 2030 GHG reduction target, at least cost, while maintaining electric service reliability and meeting other state goals. In subsequent years, the CPUC has been developing integrated resource plans and transmitting them to the ISO for use in the annual transmission planning process.

The CPUC issued Decision 24-02-047<sup>2</sup> adopting a Preferred System Plan (PSP) portfolio and a sensitivity portfolio for use in the 2024-2025 Transmission Planning Process (TPP). The portfolios are based on the 25 million metric ton (MMT) greenhouse gas (GHG) target for the electric sector in 2035 and the California Energy Commission's 2022 Integrated Energy Policy Report demand forecast. The PSP portfolio is used to identify reliability and policy-driven transmission needs for approval in the ISO 2024-2025 TPP. The sensitivity portfolio is designed to test the transmission buildout needed for a grid stress case where about 16 GW of natural gas generation resources are retired by 2039. The Decision is accompanied by a document

---

<sup>1</sup> <https://docs.cpuc.ca.gov/PublishedDocs/Published/G000/M209/K878/209878964.PDF>

<sup>2</sup> <https://docs.cpuc.ca.gov/PublishedDocs/Published/G000/M525/K918/525918033.PDF>

entitled Modeling Assumptions for the 2024-2025 Transmission Planning Process<sup>3</sup>, which provides the methodology and results of the resources-to-busbar mapping process as well as other assumptions for use in the ISO TPP.

## F.2 Objectives of policy-driven assessment

Key objectives of the policy-driven assessment are to:

- Assess the transmission impacts of portfolio resources using:
  - Reliability assessment,
  - Peak and Off-peak deliverability assessment, and
  - Production cost simulation;
- Identify transmission upgrades or other solutions needed to ensure reliability deliverability or alleviate excessive curtailment; and
- Gain further insights to inform future portfolio development.
- Set out the zonal capacities that are being established through coordinated transmission planning and resource planning, to shape and guide interconnection and resource procurement.

## F.3 Study methodology and components

The policy-driven assessment is an iterative process comprised of three types of technical studies as illustrated in Figure F.3-1. These studies are geared towards capturing the impact of the resource build-out on transmission infrastructure, identifying any required upgrades and generating transmission-related input for use by the CPUC in the next cycle of portfolio development.

---

<sup>3</sup> [https://www.cpuc.ca.gov/-/media/cpuc-website/divisions/energy-division/documents/integrated-resource-plan-and-long-term-procurement-plan-irp-ltpp/2023-irp-cycle-events-and-materials/assumptions-for-the-2024-2025-tpp/modeling\\_assumptions\\_24-25tpp.pdf](https://www.cpuc.ca.gov/-/media/cpuc-website/divisions/energy-division/documents/integrated-resource-plan-and-long-term-procurement-plan-irp-ltpp/2023-irp-cycle-events-and-materials/assumptions-for-the-2024-2025-tpp/modeling_assumptions_24-25tpp.pdf)

Figure F.3-1: Policy-Driven Assessment Technical Studies

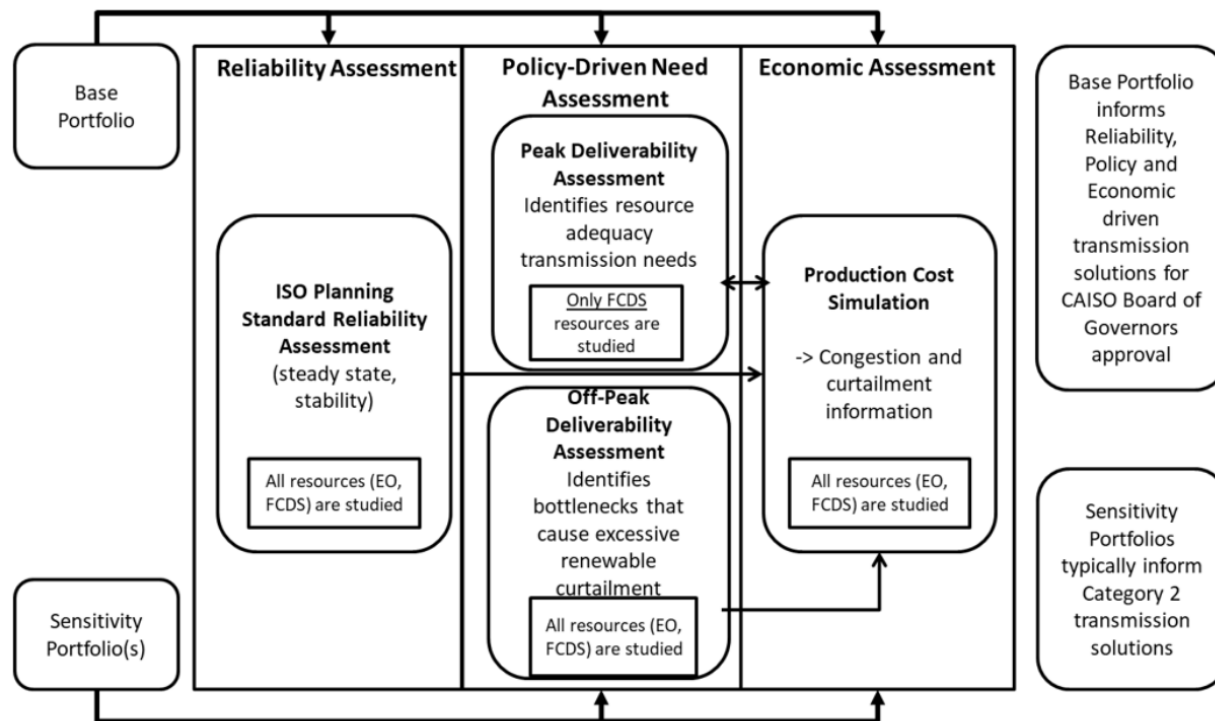

**Reliability assessment**

The CPUC’s base resource portfolio is a key input in the ISO’s long term reliability assessment. The reliability assessment is used to assess transmission needs in accordance with NERC, WECC and CAISO transmission planning standards and criteria. It is also used to identify constraints and potential solutions that may be modeled in production cost simulations to assess the impact of the constraints on congestion and renewable curtailment, which may lead to identification of economic transmission projects. The reliability assessment is presented in Chapter 2 and Appendix B.

**On-peak deliverability assessment**

The on-peak deliverability assessment is designed to ensure portfolio resources selected with full capacity deliverability status (FCDS) are deliverable and can count towards meeting resource adequacy needs. The assessment examines whether sufficient transmission capability exists to transfer resource output from a given area to the aggregate of the ISO control-area load when the generation is needed most. The ISO performs the assessment in accordance with its On-peak Deliverability Assessment Methodology.<sup>4</sup>

<sup>4</sup> <https://www.caiso.com/documents/on-peak-deliverability-assessment-methodology.pdf>

### Off-peak deliverability assessment

The off-peak deliverability assessment is performed to identify potential transmission system limitations that may cause excessive renewable energy curtailment. Like the reliability assessment, the offpeak assessment is also used to identify constraints and transmission solutions as candidates for detailed production cost simulation studies and economic assessment. The ISO performs the assessment in accordance with its Off-Peak Deliverability Assessment Methodology.<sup>5</sup>

### Production cost model (PCM) simulation

Production cost models for the base and sensitivity portfolios are developed and simulated to identify renewable curtailment and transmission congestion in the ISO Balancing Authority Area. The PCM for the base portfolio is used in the policy-driven assessment that is covered in this section as well as the economic assessment covered in Chapter 4 and Appendix G. The PCM with the sensitivity portfolio is used in the policy-driven assessment only. The PCM cases are developed based on study assumptions for the ISO-controlled grid outlined in the 2024-2025 transmission planning process study plan. Details of PCM modeling assumptions and approaches are provided in Appendix G.

## F.4 Resource Portfolios

As mentioned in Section F.1, the 2023 PSP base portfolio and high gas generation retirement sensitivity portfolio were transmitted by the CPUC for study in the ISO 2024-2025 transmission planning process. The portfolio documents are available at the CPUC website.<sup>6</sup>

The following documents provide details regarding the base portfolio.

Final 2034 and 2039 busbar mapping results for the base portfolio: [https://www.cpuc.ca.gov/-/media/cpuc-website/divisions/energy-division/documents/integrated-resource-plan-and-long-term-procurement-plan-irp-ltpp/2023-irp-cycle-events-and-materials/assumptions-for-the-2024-2025-tpp/final\\_dashboard\\_24-25tpp\\_02-15-24.xlsx](https://www.cpuc.ca.gov/-/media/cpuc-website/divisions/energy-division/documents/integrated-resource-plan-and-long-term-procurement-plan-irp-ltpp/2023-irp-cycle-events-and-materials/assumptions-for-the-2024-2025-tpp/final_dashboard_24-25tpp_02-15-24.xlsx)

Final 2039 busbar mapping results for the high gas generation retirement sensitivity portfolio: [https://www.cpuc.ca.gov/-/media/cpuc-website/divisions/energy-division/documents/integrated-resource-plan-and-long-term-procurement-plan-irp-ltpp/2023-irp-cycle-events-and-materials/assumptions-for-the-2024-2025-tpp/dashboard\\_gasretire\\_sensitivity\\_02152024.xlsx](https://www.cpuc.ca.gov/-/media/cpuc-website/divisions/energy-division/documents/integrated-resource-plan-and-long-term-procurement-plan-irp-ltpp/2023-irp-cycle-events-and-materials/assumptions-for-the-2024-2025-tpp/dashboard_gasretire_sensitivity_02152024.xlsx)

Baseline reconciliation and in-development resources: [https://www.cpuc.ca.gov/-/media/cpuc-website/divisions/energy-division/documents/integrated-resource-plan-and-long-term-procurement-plan-irp-ltpp/2023-irp-cycle-events-and-materials/assumptions-for-the-2024-2025-tpp/baseline\\_reconcile\\_ruling\\_10-05-23.xlsx](https://www.cpuc.ca.gov/-/media/cpuc-website/divisions/energy-division/documents/integrated-resource-plan-and-long-term-procurement-plan-irp-ltpp/2023-irp-cycle-events-and-materials/assumptions-for-the-2024-2025-tpp/baseline_reconcile_ruling_10-05-23.xlsx)

Retirement list of thermal generation units: <https://www.cpuc.ca.gov/-/media/cpuc-website/divisions/energy-division/documents/integrated-resource-plan-and-long-term->

---

<sup>5</sup> <http://www.caiso.com/Documents/Off-PeakDeliverabilityAssessmentMethodology.pdf>

<sup>6</sup> <https://www.cpuc.ca.gov/industries-and-topics/electrical-energy/electric-power-procurement/long-term-procurement-planning/2022-irp-cycle-events-and-materials/assumptions-for-the-2024-2025-tpp>



[procurement-plan-irp-ltpp/2023-irp-cycle-events-and-materials/assumptions-for-the-2024-2025-tpp/gasnotretained\\_mappingresults.xlsx](https://procurement-plan-irp-ltpp/2023-irp-cycle-events-and-materials/assumptions-for-the-2024-2025-tpp/gasnotretained_mappingresults.xlsx)

The composition of each of the portfolios by resource type is provided in Table F.4-1. The table includes resources selected with Full Capacity Deliverability Status (FCDS) as well as those selected as Energy Only (EO). The numbers also include any portfolio adjustments based on CPUC guidance including unaccounted for TPD allocation modeled and additional in-development resources modeled by PTOs based on projects status. The portfolios are comprised of solar, wind (in-state, out-of-state and offshore), battery storage, geothermal, long duration energy storage, biomass/biogas and distributed solar resources. All portfolio resources are modeled in policy-driven assessments except in the on-peak deliverability assessment in which only FCDS resources are modeled. The portfolios assume some of the existing gas-fired generation fleet will be retired.

Table F.4-1: Portfolio composition – FCDS+EO resources (MW)<sup>7</sup>

| Resource Type                            | 2034 Base Portfolio |               |               | 2039 Base Portfolio |               |               | 2039 Sensitivity Portfolio |               |               |
|--|---------------------|---------------|---------------|---------------------|---------------|---------------|----------------------------|---------------|---------------|
|  | FCDS (MW)           | EO (MW)       | Total (MW)    | FCDS (MW)           | EO (MW)       | Total (MW)    | FCDS (MW)                  | EO (MW)       | Total (MW)    |
| Solar                                    | 8,501               | 10,715        | 19,216        | 10,878              | 19,608        | 30,486        | 21,324                     | 30,614        | 51,938        |
| Wind – In State                          | 5,203               | 921           | 6,123         | 6,103               | 921           | 7,023         | 4,885                      | 855           | 5,739         |
| Wind – Out-of-State                      | 6,096               | 0             | 6,096         | 9,096               | 0             | 9,096         | 7,066                      | 0             | 7,066         |
| Wind - Offshore                          | 3,855               | 0             | 3,855         | 4,531               | 0             | 4,531         | 0                          | 0             | 0             |
| Li Battery – 4 hr                        | 18,951              | 468           | 19,419        | 18,227              | 468           | 18,695        | 13,047                     | 468           | 13,515        |
| Li Battery – 8 hr                        | 1,618               | 0             | 1,618         | 7,115               | 0             | 7,115         | 15,612                     | 0             | 15,612        |
| Long Duration Energy Storage (LDES)      | 1,030               | 0             | 1,030         | 1,080               | 0             | 1,080         | 3,680                      | 0             | 3,680         |
| Geothermal                               | 1,969               | 0             | 1,969         | 1,969               | 0             | 1,969         | 5,089                      | 0             | 5,089         |
| Biomass/Biogas                           | 171                 | 0             | 171           | 171                 | 0             | 171           | 22                         | 0             | 22            |
| Distributed Solar                        | 260                 | 0             | 260           | 283                 | 0             | 283           | 335                        | 0             | 335           |
| Net Dependable Gas Capacity not Retained | (3,448)             | 0             | (3,448)       | (4,418)             | 0             | (4,418)       | (12,274)                   | 0             | (12,274)      |
| <b>Total</b>                             | <b>44,206</b>       | <b>12,104</b> | <b>56,309</b> | <b>55,035</b>       | <b>20,997</b> | <b>76,031</b> | <b>58,786</b>              | <b>31,937</b> | <b>90,722</b> |

The portfolios that RESOLVE generates are at the zonal level. As a result, the portfolios have to be mapped to the busbar level for use in the ISO transmission planning process. The resource-to-busbar mapping process is documented in the CPUC report entitled Methodology for

<sup>7</sup> [https://files.cpuc.ca.gov/energy/modeling/BusbarMapping\\_30MMT\\_HESens\\_Dashboard\\_08\\_22\\_22\\_TPD\\_v2.xlsx](https://files.cpuc.ca.gov/energy/modeling/BusbarMapping_30MMT_HESens_Dashboard_08_22_22_TPD_v2.xlsx)

Resource-to-Busbar Mapping & Assumptions for the Annual TPP<sup>8</sup> with further refinements as described in the CPUC staff report entitled Modeling Assumptions for the 2023-2024 Transmission Planning Process.<sup>9</sup> Figure F.4-1 shows a flowchart of the CPUC busbar mapping process for the 2023-2024 transmission planning process.

Figure F.4-1: Flowchart of the CPUC 2023-2024 TPP busbar mapping process<sup>10</sup>

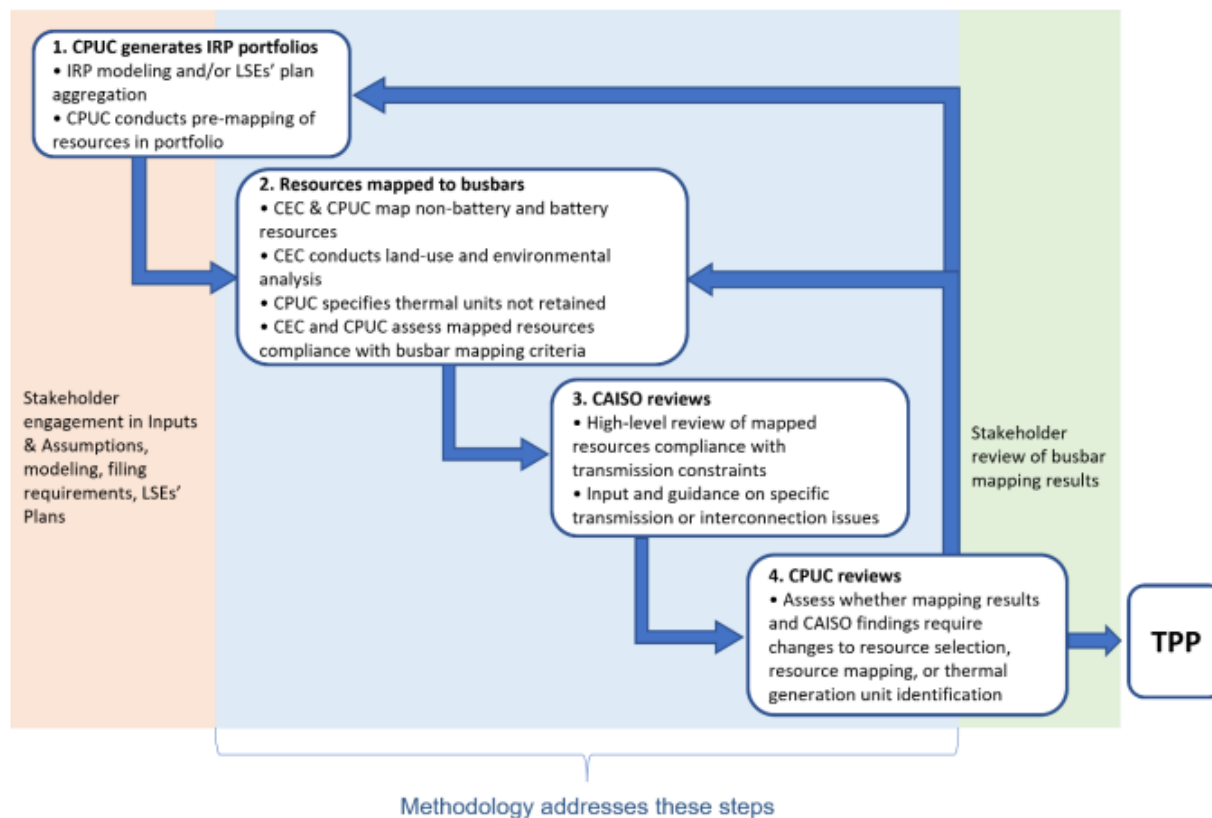

The portfolio resources were modeled in the ISO studies in accordance with the results of the mapping process. Figure F.4-2 below identifies the interconnection areas and the capacities of the resources in the CPUC's base and sensitivity portfolios. The resource types within each interconnection area and the mapping of the resources is provided in the sections below. Links to the detailed busbar mapping results have been provided in section F.4.

<sup>8</sup> <https://www.cpuc.ca.gov/-/media/cpuc-website/divisions/energy-division/documents/integrated-resource-plan-and-long-term-procurement-plan-irp-ltpp/2022-irp-cycle-events-and-materials/2023-2024-tpp-portfolios-and-modeling-assumptions/busbarmethodologyfortppv20230109.pdf>

<sup>9</sup> [https://www.cpuc.ca.gov/-/media/cpuc-website/divisions/energy-division/documents/integrated-resource-plan-and-long-term-procurement-plan-irp-ltpp/2023-irp-cycle-events-and-materials/modeling\\_assumptions\\_2023-24tpp\\_v02-23-23.pdf](https://www.cpuc.ca.gov/-/media/cpuc-website/divisions/energy-division/documents/integrated-resource-plan-and-long-term-procurement-plan-irp-ltpp/2023-irp-cycle-events-and-materials/modeling_assumptions_2023-24tpp_v02-23-23.pdf)

<sup>10</sup> <https://www.cpuc.ca.gov/-/media/cpuc-website/divisions/energy-division/documents/integrated-resource-plan-and-long-term-procurement-plan-irp-ltpp/2022-irp-cycle-events-and-materials/2023-2024-tpp-portfolios-and-modeling-assumptions/busbarmethodologyfortppv20230109.pdf>

Figure F.4-2: Base and Sensitivity Portfolios Total MW in each Interconnection Area

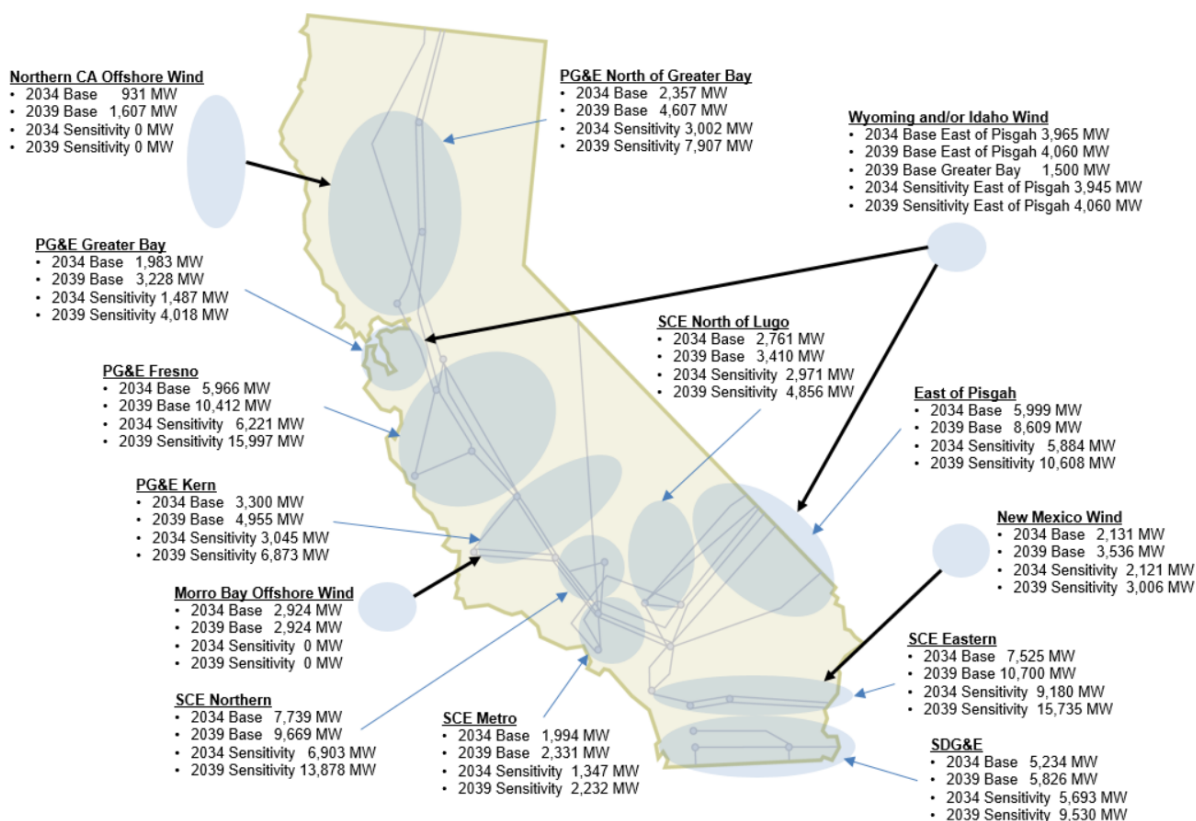

### F.4.1 Approved Non-CPUC Jurisdictional Integrated Resource Plans

In this TPP cycle, approved IRP submitted by non-CPUC jurisdictional entities has been incorporated in the analysis with the CPUC busbar mapped IRP base portfolio. Future resources identified in the Northern California Power Agency (NCPA) 2023 Inter-Agency Resource Plan (2023 IARP) and approved IRP from Colton, Banning and Six Cities were submitted as comments to the 2024-2025 transmission draft study plan. Existing resources included in the non-CPUC jurisdictional entities’ resource plans appear to have already been included in the TPP study models and as a result will not impact the assessment. There was one new resource from NCPA being included in the 2024-2025 TPP policy study based on the details provided by this entity. The CAISO will continue to coordinate with the non-CPUC jurisdictional entities in the future planning cycles on resources that have not been included as baseline or portfolio resources in the CPUC IRP, or in the starting WECC or PTO power flow models.

### F.4.2 Transmission capability estimates and utilization by portfolios

One of the key inputs in the portfolio development and busbar mapping process is the transmission capability estimates provided by the ISO. The transmission capability estimates limit the amount of FCDS and EODS resources that can be selected in the part of the system

that is affected by the constraint. Due to timing, the previous transmission capability estimates the ISO published in a white paper on June 29, 2023<sup>11</sup> were used in the development of the resource portfolios for the current TPP. Some capability estimates have been updated by CPUC based on information provided by the ISO.

The utilization of estimated available FCDS and EODS transmission capability by resource portfolios is monitored by the CPUC in the portfolio development process using RESOLVE and in the busbar mapping process using spreadsheet calculations. The results of the evaluation for the 2024-2025 TPP base portfolio based on the 2023 white paper are posted on the CPUC website<sup>12</sup>.

Exceedances of actual transmission capability limits indicate a high likelihood of the need for transmission upgrades or other mitigation solutions for the delivery of portfolio resources behind the constraints, which the CPUC takes into account in the development and mapping of the resource portfolios. However, the spreadsheet analysis should not be viewed as a substitute for the analysis the ISO performed as part of this policy-driven assessment using detailed power system models.

## F.5 Additional Guidance from CPUC regarding the Portfolios

In the Modeling Assumptions for the 2024-2025 Transmission Planning Process, CPUC staff provide the additional guidance below on the base and sensitivity portfolios. The ISO has considered this guidance when conducting the policy-driven assessment.

### Alignment with CAISO Queue Resources with Allocated TPD

As was done for the 2023-2024 TPP, CPUC staff requested that the that CAISO continue the necessary studies to inform and enable opportunities to provide Maximum Import Capability (MIC) expansion and the development of incremental transmission capacity to support the OOS and long-lead time (LLT) resources mapped in the base portfolio, while preserving the existing transmission capacity that has been allocated to other projects earlier in the interconnection queue. CPUC Working Group staff sought to align the mapping with resources in the ISO's interconnection queue that have been assigned transmission plan deliverability (TPD) while still aligning with the various other busbar mapping criteria. To that end, not all the assigned TPD in the transmission areas key to OOS and LLT resources were accounted for by mapped resources. CPUC staff compiled the MW amounts and locations of these TPD allocated resources as shown in **Error! Reference source not found.** so that the CAISO can include them in addition to the mapped portfolio resources when conducting TPP analysis<sup>13</sup>. Minor adjustments were also made to account for additional in-development resources identified by PTOs as shown in **Error! Reference source not found.**

---

<sup>11</sup> <https://www.aiso.com/Pages/documentsbygroup.aspx?GroupID=03DCF912-0ECF-4CF9-A304-A05F4ED5B2CD>

<sup>12</sup> [https://www.cpuc.ca.gov/-/media/cpuc-website/divisions/energy-division/documents/integrated-resource-plan-and-long-term-procurement-plan-irp-ltpp/2023-irp-cycle-events-and-materials/assumptions-for-the-2024-2025-tpp/final\\_dashboard\\_24-25tpp\\_02-15-24.xlsx](https://www.cpuc.ca.gov/-/media/cpuc-website/divisions/energy-division/documents/integrated-resource-plan-and-long-term-procurement-plan-irp-ltpp/2023-irp-cycle-events-and-materials/assumptions-for-the-2024-2025-tpp/final_dashboard_24-25tpp_02-15-24.xlsx) See Exceedance\_Summary tabs

<sup>13</sup> The CPUC compiled the MW amounts of TPD in Table F5-1 in February 2024 which was prior to the completion of the CAISO's 2024 TPD Allocation process in June 2024, so the TPD allocations in that process are not included in Table F5-1.

Table F.5-1: Adjustments to the base portfolio to account for adjustments to in-development resources and TPD allocations

|                           |              |         |               | TPD in key MIC regions unaccounted for by mapped resources (MWs) |              |                  |
|---------------------------|--------------|---------|---------------|--|--------------|------------------|
| CAISO Study Area          | Substation   | Voltage | Resource Type | 2034 Base  | 2039 Base    | 2039 Sensitivity |
| SCE Eastern Study Area    | Alberhill    | 500     | Storage       | 500  | 500          | 500              |
| SCE Eastern Study Area    | Cielo Azul   | 500     | Storage       | 590  | 90           | 499              |
| East of Pisgah Study Area | Eldorado     | 230     | Storage       | 250  | -            | -                |
| East of Pisgah Study Area | Mohave       | 500     | Storage       | 1,020  | 1,020        | 1,240            |
| East of Pisgah Study Area | Trout Canyon | 230     | Storage       | 1,000  | 527          | 975              |
| <b>Total</b>              |              |         |               | <b>3,360</b>   | <b>2,137</b> | <b>3,214</b>     |

Table F.5-2: Adjustments to the base portfolio to account additional in-development resources identified

|                   |             |         |               | 2034 Base Portfolio |            |              | 2039 Base Portfolio |            |            | 2039 Sensitivity Portfolio |            |              |
|-------------------|-------------|---------|---------------|---------------------|------------|--------------|---------------------|------------|------------|----------------------------|------------|--------------|
| Transmission Area | Substation  | Voltage | Resource Type | FCDS (MW)           | EODS (MW)  | Total (MW)   | FCDS (MW)           | EODS (MW)  | Total (MW) | FCDS (MW)                  | EODS (MW)  | Total (MW)   |
| SCE Northern Area | Windhub     | 230     | Li Battery    | 375                 | -          | 375          | 125                 | -          | 125        | 250                        | -          | 250          |
| SCE Northern Area | Windhub     | 230     | Solar         | -                   | 400        | 400          | -                   | -          | -          | -                          | -          | -            |
| SCE Northern Area | Windhub     | 66      | Solar         | 20                  | -          | 20           | 20                  | -          | 20         | 20                         | -          | 20           |
| SCE Northern Area | Rector      | 66      | Li Battery    | 80                  | -          | 80           | 80                  | -          | 80         | 80                         | -          | 80           |
| SCE Northern Area | Springville | 66      | Solar         | -                   | 40         | 40           | -                   | 40         | 40         | -                          | 40         | 40           |
| SCE Northern Area | Springville | 66      | Li Battery    | 40                  | -          | 40           | 40                  | -          | 40         | 40                         | -          | 40           |
| SCE NOL Area      | Coolwater   | 115     | Li Battery    | 8                   | -          | 8            | 8                   | -          | 8          | 28                         | -          | 28           |
| SCE NOL Area      | Inyokern    | 115     | Li Battery    | 46                  | -          | 46           | 46                  | -          | 46         | 46                         | -          | 46           |
| SCE NOL Area      | Victor      | 115     | Solar         | -                   | 27         | 27           | -                   | 27         | 27         | -                          | 27         | 27           |
| SCE Eastern Area  | Red Bluff   | 230     | Li Battery    | -                   | 468        | 468          | -                   | 468        | 468        | -                          | 468        | 468          |
| SCE Metro Area    | Alamitos    | 230     | Li Battery    | 84                  | -          | 84           | 84                  | -          | 84         | 84                         | -          | 84           |
| <b>Total</b>      |             |         |               | <b>653</b>          | <b>935</b> | <b>1,588</b> | <b>403</b>          | <b>535</b> | <b>938</b> | <b>548</b>                 | <b>535</b> | <b>1,083</b> |

### Out-of-State Wind on New Out-of-State Transmission

The amount of OOS wind on new transmission is significantly higher (6,095 MW in 2034 and 9,095 MW in 2039) in this base case portfolio than in the past TPP base cases. As was done for the 2023-2024 TPP base case, the Working Group mapped the out-of-state wind to specific CAISO injection points and identified specific locations as sources of the OOS wind. Minor modification was later made by the CAISO staff during the policy study process and the final mapping was as follows. For the 2034 portfolio: 1,060 MW of Idaho Wind interconnected at Harry Allen using the proposed SWIP-North line, 1,500 MW of Wyoming wind interconnected at Harry Allen using the proposed TransWest Express line while the remaining 1,405 MW Wyoming wind interconnected at Eldorado 500 kV requiring new transmission, and 2,131 MW of New Mexico Wind interconnected at Pinal Central using the proposed SunZia line and existing transmission. In 2039, the amount of New Mexico wind increases to 3,535 MW and Wyoming Wind increases to 4,500 MW. The additional New Mexico wind was assumed the same interconnection at Pinal Central. For the additional 1,500 MW Wyoming wind, the CPUC staff mapped it as interconnecting using new transmission to Northern California in the Tesla area to align with results from the CAISO's 20-year outlook (2021-2022). Though, CPUC staff again note that this is not a mandate to assume this specific intertie if alternative, more effective solutions are available, such as any being identified in the current 20-year Transmission Outlook (2023-2024) or alternative options that could potentially accommodate the wind resources identified in northeastern California and other potential northern Nevada resources.

### Out-of-CAISO Resources and Maximum Import Capability (MIC)

The 2023-24 TPP base portfolio, in addition to the over 4,800 MW of OOS wind on new transmission, has a significant amount of geothermal mapped to IID and areas in Nevada beyond the CAISO's Balancing Area. As was done for the 2022-2023 TPP portfolio, busbar Working Group staff specified in the Mapping Dashboard the out-of-CAISO transmission and MIC assumptions for these resources including whether the resources should be treated by CAISO in TPP analysis as using existing MIC allocations or require MIC expansion. For all the OOS wind on new transmission and most of the geothermal resources, Working Group staff identified the resources as requiring MIC expansion. Full details of the out-of-CAISO resources, which can be found on the "OutsideCAISO\_Res\_Summary" tab of the Mapping Dashboards, was used to model the resources.

### Battery Storage-Specific Transmission Upgrades and Battery Storage as Transmission Upgrade Alternatives

As with the past TPP portfolio submittals, CPUC requests ISO to consult the CPUC before moving forward with any new policy-driven transmission upgrades associated specifically with storage mapping in this planning cycle. Additionally, to the extent that storage resources are required for mitigation of transmission issues identified in the CAISO 2023-2024 Transmission Plan, CPUC staff expect to coordinate with CAISO to enable small adjustments in the CPUC's mapping of storage resources to allow for the inclusion of this storage in the CAISO's analysis of the 2024-2025 TPP portfolio. Such adjustments were not made as storage resources were not required for mitigation of transmission issues identified in the CAISO's 2023-2024 Transmission Plan.

## F.6 On-Peak Deliverability Assessment

The primary objective of the policy-driven on-peak deliverability assessment is to support deliverability of the renewable generation and energy storage resources that are identified in the portfolios as requiring FCDS status so they can count towards meeting resource adequacy needs. The assessment evaluates whether the net resource output from a given area can be simultaneously transferred to the remainder of the ISO Control Area during periods of peak system load. The on-peak deliverability assessment of the base and sensitivity portfolios was performed in accordance with the on-peak deliverability assessment methodology.<sup>14</sup>

### F.6.1 On-peak deliverability assessment assumptions

The deliverability assessment is performed under two distinct system conditions – the highest system need (HSN) scenario and the secondary system need (SSN) scenario. The HSN scenario represents the period when the capacity shortage is most likely to occur. In this scenario, the system reaches peak sale with low solar output. The highest system need hours represent the hours ending 19 to 22 in the summer months.

The secondary system need scenario represents the period when capacity shortage risk increases if variable resources are not deliverable during periods when the system depends on their high output for resource adequacy. In this scenario, the system load is modeled to represent the peak consumption level and solar output is modeled at a significantly higher output. The secondary system need hours are hours ending 15 to 18 in the summer months.

The ISO performed the on-peak deliverability assessment for both HSN and SSN scenarios. For each scenario and each portfolio, the ISO developed a master on-peak deliverability assessment base case from which area cases are derived. Key assumptions of the deliverability assessment are described below.

#### Transmission

The ISO modeled the same transmission system as in the 2034 and 2039 peak load base cases that are used in the reliability assessment performed as part of the current transmission planning process.

#### System load

The ISO modeled the coincident 1-in-5 year peak for the ISO balancing authority area load in the HSN base case. Pump load was dispatched within the expected range for summer peak load hours. The load in the SSN base case was adjusted from HSN to represent the net customer load at the time of forecasted peak consumption.

#### Maximum resource output (Pmax) assumptions

Pmax in the on-peak deliverability assessment represents the resource-type specific maximum resource output assumed in the deliverability assessment. For existing non-intermittent generating units, the highest summer month NQC in the last three years is used as Pmax. For proposed FCDS non-intermittent generators that do not have NQC, the Pmax is set according to

---

<sup>14</sup> <https://www.caiso.com/documents/on-peak-deliverability-assessment-methodology.pdf>

the interconnection request. For non-intermittent generic portfolio resources, the FCDS capacity provided in the portfolio is used as the Pmax. For FCDS energy storage resources, the Pmax in the HSN scenario is set to the 4-hour discharging capacity, limited by the requested maximum output from the generator. Pmax for energy storage in the SSN scenario is set at half of the HSN value. For hybrid projects, the study amount for each technology is first calculated separately. Then the total study amount among all technologies is based on the sum of each technology, but limited by the requested maximum output of the generation project.

FCDS intermittent resources are modeled in the HSN scenario based on the output profiles during the highest system need hours with low unloaded capacity levels. A 20% exceedance production level for wind and solar resources during these hours sets the Pmax tested in the HSN deliverability assessment. In the SSN scenario, intermittent resources are modeled based on the output profiles during the secondary system need hours with low unloaded capacity levels. 50% exceedance production level for wind and solar resources during those hours sets the Pmax tested in the SSN deliverability assessment.

The maximum resource output (Pmax) assumptions used in the HSN and SSN deliverability assessment for FCDS resources are shown in

Table F.6-1. For resources with partial deliverability status (PCDS), the Pmax amounts in the table are derated by the deliverable percentage.

Table F.6-1: Maximum FCDS resource output tested in the deliverability assessment

| Area                           | HSN   |     |      |     | SSN  |     |      |     |
|--------------------------------|---|-----|------|-----|--|-----|------|-----|
|                                | SDG&E   | SCE | PG&E | VEA | SDG&E  | SCE | PG&E | VEA |
| Solar                          | 6%  | 13% | 15%  | 8%  | 71%  | 80% | 71%  | 66% |
| Wind                           | 35%   | 48% | 50%  | 48% | 10%  | 17% | 19%  | 17% |
| Out-of-state Wind (NM, WY, ID) | 67%   |     |      |     | 35%  |     |      |     |
| Off-shore Wind                 | 83%   |     |      |     | 45%  |     |      |     |
| Energy Storage                 | 100% or 4-hour equivalent if duration is < 4-hour |     |      |     | 50% or 4-hour equivalent if duration is < 4-hour |     |      |     |
| Non-Intermittent resources     | NQC or 100%                                       |     |      |     |  |     |      |     |

**Import Levels**

For the HSN scenario, the net scheduled imports at all branch groups as determined in the latest annual Maximum Import Capability (MIC) assessment set the base import targets in the study. Approved MIC expansions will be added to the import levels. Historically unused Existing Transmission Contracts (ETC’s) crossing control area boundaries were modeled as zero MW



injections at the tie point, but available to be turned on at remaining contract amounts for screening analysis. MIC expansions needed to accommodate portfolio resources outside the ISO BAA are added to the import targets. Valid MIC expansion requests are similarly modeled but are not allowed to trigger transmission upgrades.

For the SSN scenario, the hour with the highest total net imports among all secondary system need hours from the latest MIC assessment data is selected. Net scheduled imports for the hour set the import targets in the study. Approved and requested MIC expansions and MIC expansions needed to accommodate portfolio resources outside the ISO BAA are modeled similar to the HSN scenario.

### **F.6.2 General On-peak deliverability assessment procedure**

The main steps of the California ISO on-peak deliverability assessment procedure are described below.

#### **Screening for Potential Deliverability Problems Using DC Power Flow Tool**

A DC transfer capability/contingency analysis tool is used to identify potential deliverability problems. For each analyzed facility, an electrical circle is drawn which includes all generating units including unused Existing Transmission Contract (ETC) injections that have a 5% (or 10% for 500 kV lines) or greater:

$$\text{Distribution factor (DFAX)} = (\Delta \text{ flow on the analyzed facility} / \Delta \text{ output of the generating unit}) * 100\%$$

**or**

$$\text{Flow impact} = (\text{DFAX} * \text{Full Study Amount} / \text{Applicable rating of the analyzed facility}) * 100\%.$$

Load flow simulations are performed, which study the worst-case combination of generator output within each 5%/10% Circle.

#### **Verifying and Refining the Analysis Using AC Power Flow Tool**

The outputs of capacity units in the 5%/10% Circle are increased starting with units with the largest impact on the transmission facility. No more than 20 units are increased to their maximum output. In addition, no more than 1,500 MW of generation is increased. All remaining generation within the Control Area is proportionally displaced, to maintain a load and resource balance.

When the 20 units with the highest impact on the facility can be increased more than 1,500 MW, the impact of the remaining amount of generation to be increased is considered using a Facility Loading Adder. The Facility Loading Adder is calculated by taking the remaining MW amount available from the 20 units with the highest impact multiplied by the DFAX of each unit. An equivalent MW amount of generation with negative DFAX is also included in the Facility Loading Adder, up to 20 units. Negative Facility Loading Adders should be set to zero.

The ISO's on-peak deliverability assessment simulation procedure as implemented in PowerGem's Transmission Adequacy & Reliability Assessment (TARA) software was used to perform the policy-driven on-peak deliverability assessment.

On-peak deliverability assessment for the 2034 and 2039 base portfolios and 2039 high gas generation retirement sensitivity portfolio were performed for both southern and northern California.

Potential mitigation options considered to address on-peak deliverability constraints include Remedial Action Schemes (RAS), reduction of energy storage behind the constraints and transmission upgrades. Transmission upgrades identified for the base portfolio HSN scenario are recommended as policy driven upgrades. Transmission upgrades identified for the base portfolio SSN scenario will go through a comprehensive economic, policy and reliability benefit analysis to be considered for approval as a policy driven or economic upgrade.

## F.7 Off-Peak Deliverability assessment

The ISO modified its on-peak deliverability assessment to reflect the changing contribution of solar to meeting resource adequacy needs. Additional solar resources provide a much lower incremental resource adequacy benefit to the system than the initial solar resources, because their output profile ceases to align with the peak hour of demand on the transmission system which has shifted to later in the day due to the proliferation of behind-the-meter solar. As a result, there is a reduced need for transmission upgrades to support deliverability of additional solar resources for resource adequacy purposes. Generation developers have been relying on transmission upgrades required under the previous on-peak deliverability assessment methodology to ensure that generation would not be exposed to excessive curtailment due to transmission limitations. Therefore, the off-peak deliverability assessment methodology<sup>15</sup> was developed to address renewable energy delivery during hours outside of the summer peak load period to ensure some minimal level of protection from otherwise potentially unlimited curtailment.

Accordingly, the key objectives of the policy-driven off-peak deliverability assessment are to:

- Identify transmission constraints that would cause excessive renewable curtailment in accordance with the off-peak deliverability methodology
- Identify potential transmission upgrades and other solutions needed to relieve excessive renewable curtailment
- Select the constraints and the identified transmission upgrades as candidates for a more thorough evaluation using production cost simulation

### F.7.1 Off-peak deliverability assessment methodology

The general system study conditions are intended to capture a reasonable scenario for the load, generation, and imports that stress the transmission system, but not coinciding with an oversupply situation. By examining the renewable curtailment data from 2018, a load level of about 55% to 60% of the summer peak load and an import level of about 6000 MW was selected for the off-peak deliverability assessment.

---

<sup>15</sup> <http://www.caiso.com/Documents/Off-PeakDeliverabilityAssessmentMethodology.pdf>

The production of wind and solar resources under the selected load and import conditions varies widely. The production duration curves for solar and wind were examined. The production level under which 90% of the annual energy was selected to set the outputs to be tested in the off-peak deliverability assessment. The dispatch of the remaining generation fleet is set by examining historical production associated with the selected renewable production levels. The hydro dispatch is about 30% of the installed capacity and the thermal dispatch is about 15%. All energy storage facilities are assumed offline.

The dispatch assumptions discussed above apply to both full capacity and energy-only resources. However, depending on the amount of generation in the portfolio, it may be impossible to balance load and resources under such conditions with all portfolio generation dispatched. The dispatch assumptions are applied to all existing, under-construction and contracted generators first, then some portfolio generators if needed to balance load and resources. This establishes a system-wide dispatch base case or master base case that is the starting case for developing each of the study area base cases to be used in the off-peak deliverability assessments. Table F.7-1 summarizes the generation dispatch assumptions in the master base case.

Table F.7-1: ISO System-Wide Generator Dispatch Assumptions

|                 | Dispatch Level |
|-----------------|----------------|
| Wind            | 44%            |
| Solar           | 68%            |
| Battery storage | 0              |
| Hydro           | 30%            |
| Thermal         | 15%            |

The off-peak deliverability assessment is performed for each study area separately. The study areas in general are the same as the reliability assessment areas in the generation interconnection studies.

Study area base cases are created from the system-wide dispatch base case. All generators in the study area, existing or future, are dispatched to a consistent output level. In order to capture local curtailment, the renewable dispatch is increased to the 90% energy level for the study area, which is higher than the system-wide 90% energy level. The study area 90% energy level was determined from representing individual plants in different areas. For out-of-state and off-shore wind, the dispatch values are based on data obtained from NREL for the PCM model.

If the renewables inside the study area are predominantly wind resources (more than 70% of total study area capacity), wind resource dispatch is increased as shown in Table F.7-2. All the solar resources in the wind pocket are dispatched at the system-wide level of 68%. If the renewables inside the study area are not predominantly wind resources, then the

dispatch assumptions in Table F.7-3 are used. The dispatch assumptions for out-of-state and off-shore wind used in the current study are provided in Table F.7-4.

Table F.7-2: Local Area Solar and Wind Dispatch Assumptions in Wind Area

|       | Wind Dispatch Level | Solar Dispatch Level |
|-------|---------------------|----------------------|
| SDG&E | 69%                 | 68%                  |
| SCE   | 64%                 |                      |
| PG&E  | 63%                 |                      |

Table F.7-3: Local Area Solar and Wind Dispatch Assumptions in Solar Area

|       | Solar Dispatch Level | Wind Dispatch Level |
|-------|----------------------|---------------------|
| SDG&E | 79%                  | 44%                 |
| SCE   | 77%                  |                     |
| PG&E  | 79%                  |                     |

Table F.7-4: Additional Local Area Dispatch Assumptions

| Resource        | Dispatch Level |
|-----------------|----------------|
| Offshore Wind   | 100%           |
| New Mexico Wind | 67%            |
| Wyoming Wind    | 67%            |

As the generation dispatch increases inside the study area, the following resource adjustment can be performed to balance the loads and resources:

- Reduce new generation outside the study area (staying within the Path 26, 4000 MW north to south, and 3000 MW south to north limits);
- Reduce thermal generation inside the study area;
- Reduce imports; and
- Reduce thermal generation outside the study area.

Once each study area case has been developed, a contingency analysis is performed for normal conditions and selected contingencies:

- Normal conditions (P0);
- Single contingency of transmission circuit (P1.2), transformer (P1.3), single pole of DC lines (P1.5) and two poles of PDCI if impacting the study area; and
- Multiple contingency of two adjacent circuits on common structures (P7.1) and loss of a bipolar DC line (P7.2).

For overloads identified under such dispatch, resources that can be re-dispatched to relieve the overloads are adjusted to determine if the overload can be mitigated:

- Existing energy storage resources are dispatched to their full four-hour charging capacity to relieve the overload;
- Thermal generators contributing to the overloads are turned off; and
- Imports contributing to the overloads are reduced to the level required to support out-of-state renewables in the RPS portfolios.

The remaining overloads after the re-dispatch will be mitigated by the identification of transmission upgrades or other solutions. Generators with 5% or higher distribution factor (DFAX) on the constraint are considered contributing generators. The distribution factor is the percentage of a particular generation unit's incremental increase in output that flows on a particular transmission line or transformer under the applicable contingency condition when the displaced generation is spread proportionally, across all dispatched resources available to scale down output proportionally. Generation units are scaled down in proportion to the dispatch level of the unit.

Off-peak deliverability assessment for the 2034 base portfolio was performed for both southern and northern California. The potential solutions considered to address off-peak deliverability constraints include Remedial Action Schemes (RAS), dispatching available battery storage behind the constraints and transmission upgrades. Transmission upgrades identified to address off-peak deliverability constraints will be considered as candidates for a more thorough evaluation using production cost simulation.

## F.8 PG&E North of Greater Bay Interconnection Area

The total capacity of resources, by resource type, selected with Full Capacity Deliverability Status (FCDS) as well as those selected as Energy Only (EO) in the PG&E North of Greater Bay interconnection area are listed in Table F.8-1. The portfolios in the interconnection area are comprised of solar, wind (in-state and offshore), battery storage, geothermal, biomass/biogas and distributed solar resources. All portfolio resources are modeled in policy-driven assessments except in the on-peak deliverability assessment in which only FCDS resources are modeled.

Table F.8-1: PG&E North of Greater Bay Interconnection Area – Base and Sensitivity Portfolios by Resource Types (FCDS, EO and Total)

| Resource Type                       | 2034 Base Portfolio |            |              | 2039 Base Portfolio |              |              | 2039 Sensitivity Portfolio |              |              |
|-------------------------------------|---------------------|------------|--------------|---------------------|--------------|--------------|----------------------------|--------------|--------------|
|                                     | FCDS (MW)           | EO (MW)    | Total (MW)   | FCDS (MW)           | EO (MW)      | Total (MW)   | FCDS (MW)                  | EO (MW)      | Total (MW)   |
| Solar                               | 275                 | 320        | 595          | 430                 | 1,115        | 1,545        | 1,275                      | 2,457        | 3,732        |
| Wind – In State                     | 778                 | 320        | 1,097        | 1,678               | 320          | 1,997        | 674                        | 260          | 933          |
| Wind – Out-of-State                 | 0                   | 0          | 0            | 1,500               | 0            | 1,500        | 0                          | 0            | 0            |
| Wind - Offshore                     | 931                 | 0          | 931          | 1,607               | 0            | 1,607        | 0                          | 0            | 0            |
| Li Battery – 4 hr                   | 293                 | 0          | 293          | 293                 | 0            | 293          | 93                         | 0            | 93           |
| Li Battery – 8 hr                   | 88                  | 0          | 88           | 488                 | 0            | 488          | 1,073                      | 0            | 1,073        |
| Long Duration Energy Storage (LDES) | 5                   | 0          | 5            | 5                   | 0            | 5            | 959                        | 0            | 959          |
| Geothermal                          | 144                 | 0          | 144          | 144                 | 0            | 144          | 1,074                      | 0            | 1,074        |
| Biomass/Biogas                      | 96                  | 0          | 96           | 96                  | 0            | 96           | 6                          | 0            | 6            |
| Distributed Solar                   | 37                  | 0          | 37           | 37                  | 0            | 37           | 37                         | 0            | 37           |
| <b>Total</b>                        | <b>2,647</b>        | <b>639</b> | <b>3,287</b> | <b>6,279</b>        | <b>1,434</b> | <b>7,713</b> | <b>5,191</b>               | <b>2,716</b> | <b>7,907</b> |

The resources as identified in the CPUC busbar mapping for the PG&E North of Greater Bay interconnection area are illustrated on the single-line diagrams in Figure F.8-1 and Figure F.8-2. No adjustments were made to the portfolios in this area to account for allocated TPD and additional in-development resources identified.

Figure F.8-1: North of Greater Bay Interconnection Area – Mapped 2034 Base Portfolio

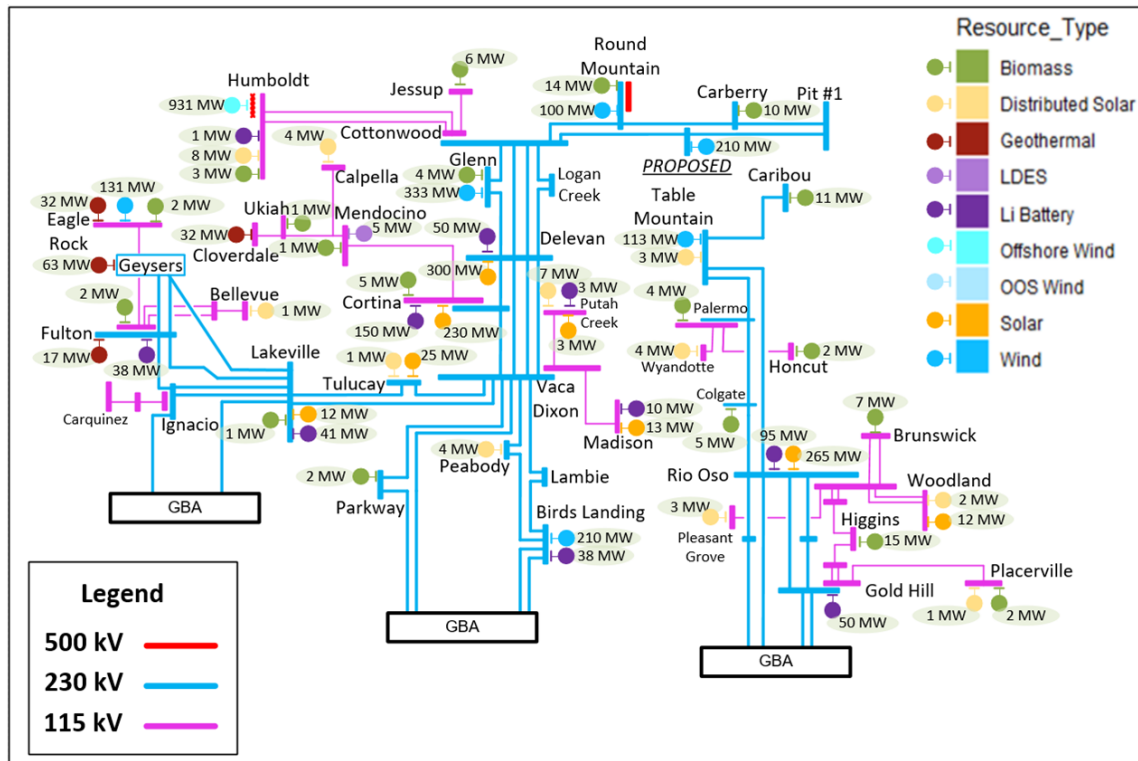
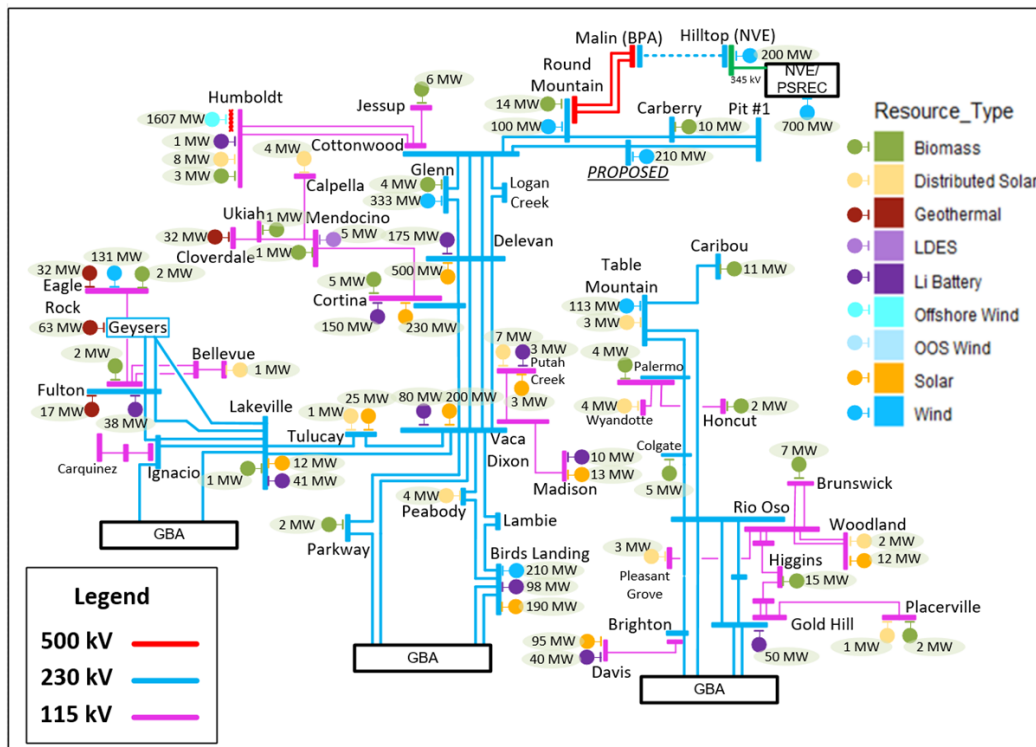

Figure F.8-2: North of Greater Bay Interconnection Area – Mapped 2039 Base Portfolio



With the resource mix specified in **Error! Reference source not found.** modeled in the base cases, the on-peak deliverability assessment identified the following constraints in PG&E study areas:

**F.8.1 2034 On-peak results**

**Hopland Bank 115/60 kV #2 on-peak deliverability constraint**

The deliverability of renewable portfolio resources in the Northern California area is limited by thermal overloading of the Hopland Bank 115/60 kV #2 under N-2 conditions as shown in Table F.8-2. This constraint was identified in baseline portfolio under HSN conditions. As shown in Table F.8-3, 39 MW of renewable and energy storage would be deliverable without any transmission upgrades. The constraint can be mitigated by a planned PG&E maintenance project.

Table F.8-2: Hopland Bank 115/60 kV #2 on-peak deliverability constraint

| Overloaded Facility           | Contingency  | Scenario | Loading |         |
|-------------------------------|--|----------|---------|---------|
|                               |  |          | HSN     | SSN     |
| HOPLAND BANK 115/60 BANK NO.2 | GEYSERS #9-LAKEVILLE & EAGLE ROCK-FULTON-SILVERADO LINES | HSN      | 139.72% | 124.25% |

Table F.8-3: Hopland Bank 115/60 kV #2 on-peak deliverability constraint summary

|  |                                     |                           |
|--|-------------------------------------|---------------------------|
| Affected transmission zones  |                                     | North of Greater Bay Area |
| Portfolio resources behind the constraint (Installed FCDS capacity)            |                                     | 202                       |
| Portfolio battery storage behind the constraint (Installed FCDS capacity)      |                                     | 0                         |
| Deliverable portfolio resources w/o mitigation (Installed FCDS capacity)       |                                     | 39                        |
| Total undeliverable baseline and portfolio resources (Installed FCDS capacity) |                                     | 239                       |
| Mitigation Options   | RAS                                 | N/A                       |
|  | Reduce generic battery storage (MW) | N/A                       |
|  | Transmission upgrade including cost | Maintenance Project       |
| Recommended Mitigation   |                                     | Maintenance Project       |

**Ukiah-Hopland-Cloverdale 115 kV (Ukiah sub 115 kV to Hopland Jct 115 kV) line on-peak deliverability constraint**

The deliverability of renewable portfolio resources in the Northern California area is limited by thermal overloading of the Ukiah-Hopland-Cloverdale 115 kV 115 kV line under N-2 conditions as shown in Table F.8-4. This constraint was identified in baseline portfolio under HSN



conditions. As shown in Table F.8-5, 0 MW of renewable and energy storage would be deliverable without any transmission upgrades. The constraint would be considered a local constraint and therefore will be addressed through the GIP.

Table F.8-4: Ukiah-Hopland-Cloverdale 115 kV (Ukiah sub 115 kV to Hopland Jct 115 kV) line on-peak deliverability constraint

| Overloaded Facility  | Contingency                                     | Scenario | Loading |       |
|--|---|----------|---------|-------|
|  |   |          | HSN     | SSN   |
| Ukiah-Hopland-Cloverdale 115 kV (Ukiah sub 115kv to Hopland Jct 115kv) | EAGLE ROCK -REDBUD & CORTINA-MENDOCINO #1 LINES | HSN      | 117.78% | <100% |

Table F.8-5: Ukiah-Hopland-Cloverdale 115 kV (Ukiah sub 115 kV to Hopland Jct 115 kV) line on-peak deliverability constraint summary

|  |                                     |   |
|--|-------------------------------------|---|
| Affected transmission zones  |                                     | North of Greater Bay Area   |
| Portfolio resources behind the constraint (Installed FCDS capacity)            |                                     | 191   |
| Portfolio battery storage behind the constraint (Installed FCDS capacity)      |                                     | 0   |
| Deliverable portfolio resources w/o mitigation (Installed FCDS capacity)       |                                     | 0   |
| Total undeliverable baseline and portfolio resources (Installed FCDS capacity) |                                     | 455   |
| Mitigation Options   | RAS                                 | N/A   |
|  | Reduce generic battery storage (MW) | N/A   |
|  | Transmission upgrade including cost | This constraint is a currently identified LDNU and will be addressed in GIP |
| Recommended Mitigation   |                                     | This constraint is a currently identified LDNU and will be addressed in GIP |

**Geyser # 3 - Cloverdale 115 kV (Cloverdale 115 kV to MPE TAP 115 kV) line on-peak deliverability constraint**

The deliverability of renewable portfolio resources in the Northern California area is limited by thermal overloading of the Geyser # 3 - Cloverdale 115 kV (Cloverdale 115 kV to MPE TAP 115 kV) line under N-2 conditions as shown in Table F.8-6. This constraint was identified in baseline portfolio under HSN conditions. As shown in Table F.8-7, 0 MW of renewable and energy

storage would be deliverable without any transmission upgrades. The constraint would be considered a local constraint and therefore will be addressed through the GIP.

Table F.8-6: Geyser # 3 - Cloverdale 115kV (Cloverdale 115kV to MPE TAP 115kV) line on-peak deliverability constraint

| Overloaded Facility   | Contingency                                     | Scenario | Loading |       |
|---|---|----------|---------|-------|
|   |   |          | HSN     | SSN   |
| Geyser # 3 - Cloverdale 115kV (Cloverdale 115kV to MPE TAP 115kV) | EAGLE ROCK -REDBUD & CORTINA-MENDOCINO #1 LINES | HSN      | 102.64% | <100% |

Table F.8-7: Geyser # 3 - Cloverdale 115 kV (Cloverdale 115 kV to MPE TAP 115 kV) line on-peak deliverability constraint summary

|  |                                     |   |
|--|-------------------------------------|---|
| Affected transmission zones  |                                     | North of Greater Bay Area   |
| Portfolio resources behind the constraint (Installed FCDS capacity)            |                                     | 159   |
| Portfolio battery storage behind the constraint (Installed FCDS capacity)      |                                     | 0   |
| Deliverable portfolio resources w/o mitigation (Installed FCDS capacity)       |                                     | 0   |
| Total undeliverable baseline and portfolio resources (Installed FCDS capacity) |                                     | 353   |
| Mitigation Options   | RAS                                 | N/A   |
|  | Reduce generic battery storage (MW) | N/A   |
|  | Transmission upgrade including cost | This constraint is a currently identified LDNU and will be addressed in GIP |
| Recommended Mitigation   |                                     | This constraint is a currently identified LDNU and will be addressed in GIP |

**Fulton – Hopland 60 kV Line (Hopland Jct. 60 kV to Cloverdale Jct. 60 kV) line on-peak deliverability constraint**

The deliverability of renewable portfolio resources in the Northern California area is limited by thermal overloading of several lines in the Fulton – Hopland 60 kV Line (Hopland Jct. 60 kV to Cloverdale Jct. 60 kV) line under N-2 conditions as shown in Table F.8-8. This constraint was identified in baseline portfolio under HSN conditions. As shown in Table F.8-9, 53 MW of renewable and energy storage would be deliverable without any transmission upgrades. The

constraint would be considered a local constraint and therefore will be addressed through the GIP.

Table F.8-8: Fulton – Hopland 60 kV Line (Hopland Jct. 60 kV to Cloverdale Jct. 60 kV) line on-peak deliverability constraint

| Overloaded Facility   | Contingency  | Scenario | Loading |         |
|---|--|----------|---------|---------|
|   |  |          | HSN     | SSN     |
| Fulton - Hopland 60 kV (Hopland Jct 60 kV to Cloverdale Jct 60 kV to Geysers Jct 60 kV) | GEYSERS #9-LAKEVILLE & EAGLE ROCK-FULTON-SILVERADO LINES | HSN      | 166.10% | 160.46% |

Table F.8-9: Fulton – Hopland 60 kV Line (Hopland Jct. 60 kV to Cloverdale Jct. 60 kV) line on-peak deliverability constraint summary

|  |                                     |   |
|--|-------------------------------------|---|
| Affected transmission zones  |                                     | North of Greater Bay Area   |
| Portfolio resources behind the constraint (Installed FCDS capacity)            |                                     | 202   |
| Portfolio battery storage behind the constraint (Installed FCDS capacity)      |                                     | 150   |
| Deliverable portfolio resources w/o mitigation (Installed FCDS capacity)       |                                     | 53  |
| Total undeliverable baseline and portfolio resources (Installed FCDS capacity) |                                     | 350   |
| Mitigation Options   | RAS                                 | N/A   |
|  | Reduce generic battery storage (MW) | N/A   |
|  | Transmission upgrade including cost | This constraint is a currently identified LDNU and will be addressed in GIP |
| Recommended Mitigation   |                                     | This constraint is a currently identified LDNU and will be addressed in GIP |

**Geyser #3 - Eagle Rock 115 kV Line on-peak deliverability constraint**

The deliverability of renewable portfolio resources in the Northern California area is limited by thermal overloading of the Geyser #3 - Eagle Rock 115 kV line under N-2 conditions as shown in Table F.8-10. This constraint was identified in baseline portfolio under HSN conditions. As shown in Table F.8-11, 64 MW of renewable and energy storage would be deliverable without any transmission upgrades. The constraint would be considered a local constraint and therefore will be addressed through the GIP.

Table F.8-10: Geyser #3 - Eagle Rock 115 kV Line on-peak deliverability constraint

| Overloaded Facility                | Contingency                                      | Scenario | Loading |         |
|------------------------------------|--|----------|---------|---------|
|                                    |  |          | HSN     | SSN     |
| Geyser #3 - Eagle Rock 115 kV Line | MENDOCINO-UKIAH & UKIAH-HOPLAND-CLOVERDALE LINES | HSN      | 113.95% | 116.25% |

Table F.8-11: Geyser #3 - Eagle Rock 115 kV Line on-peak deliverability constraint summary

|  |                                     |   |
|--|-------------------------------------|---|
| Affected transmission zones  |                                     | North of Greater Bay Area   |
| Portfolio resources behind the constraint (Installed FCDS capacity)            |                                     | 90  |
| Portfolio battery storage behind the constraint (Installed FCDS capacity)      |                                     | 0   |
| Deliverable portfolio resources w/o mitigation (Installed FCDS capacity)       |                                     | 64  |
| Total undeliverable baseline and portfolio resources (Installed FCDS capacity) |                                     | 30  |
| Mitigation Options   | RAS                                 | N/A   |
|  | Reduce generic battery storage (MW) | N/A   |
|  | Transmission upgrade including cost | This constraint is a currently identified LDNU and will be addressed in GIP |
| Recommended Mitigation   |                                     | This constraint is a currently identified LDNU and will be addressed in GIP |

**Eagle Rock- Fulton- Silverado 115 kV line (Eagle rock sub to Ricon Jct 115 kV) on-peak deliverability constraint**

The deliverability of renewable portfolio resources in the Northern California area is limited by thermal overloading of the Eagle Rock- Fulton- Silverado 115 kV line (Eagle rock sub to Ricon Jct 115 kV) under N-2 conditions as shown in Table F.8-12. This constraint was identified in baseline portfolio under HSN conditions. As shown in Table F.8-13, 147 MW of renewable and energy storage would be deliverable without any transmission upgrades. The constraint would be mitigated by reconductoring the Eagle Rock- Fulton- Silverado 115 kV line.

Table F.8-12: Eagle Rock- Fulton- Silverado 115 kV line (Eagle rock sub to Ricon Jct 115 kV) on-peak deliverability constraint

| Overloaded Facility | Contingency | Scenario | Loading |
|---------------------|-------------|----------|---------|
|---------------------|-------------|----------|---------|

|  |  |     | HSN     | SSN   |
|--|--|-----|---------|-------|
| Eagle Rock- Fulton- Silverado 115 kv (Eagle rock sub to Ricon Jct Jct2 115 kv) | Tulucay-Vaca 230 kV Line & Vaca-Lakeville #1 230 kV Line | HSN | 124.45% | <100% |

Table F.8-13: Eagle Rock- Fulton- Silverado 115 kV (Eagle rock sub to Ricon Jct 115 kV) on-peak deliverability constraint summary

|  |                                     |                           |
|--|-------------------------------------|---------------------------|
| Affected transmission zones  |                                     | North of Greater Bay Area |
| Portfolio resources behind the constraint (Installed FCDS capacity)            |                                     | 282                       |
| Portfolio battery storage behind the constraint (Installed FCDS capacity)      |                                     | 150                       |
| Deliverable portfolio resources w/o mitigation (Installed FCDS capacity)       |                                     | 147                       |
| Total undeliverable baseline and portfolio resources (Installed FCDS capacity) |                                     | 290                       |
| Mitigation Options   | RAS                                 | N/A                       |
|  | Reduce generic battery storage (MW) | N/A                       |
|  | Transmission upgrade including cost | Reconductor (\$92.9M)     |
| Recommended Mitigation   |                                     | Reconductor               |

**Eagle Rock- Fulton- Silverado 115 kV Line Reconductor**

To mitigate overloads identified in the on-peak baseline deliverability study, the ISO is recommending for approval the reconductor of the Eagle Rock- Fulton- Silverado 115 kV line. The estimated project cost is \$92.9M, with an estimated time to construct of 64 months. The scope Reconductor Eagle Rock-020/087A with minimum rating of 1236 Amps or higher and update any limiting components at the substation (if any). Reconductor 020/87A-037/191A with minimum rating of 1687 Amps or higher and update any limiting components at the substation (if any).

Figure F.8-3: Eagle Rock- Fulton- Silverado 115 kV Line Reconductor

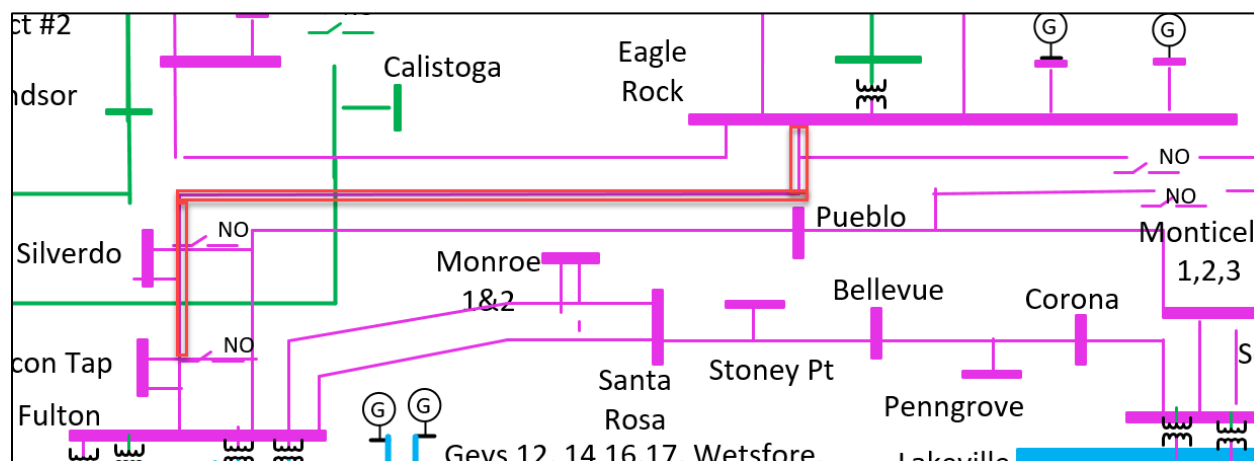

**Konocti - Eagle Rock 60 kV line on-peak deliverability constraint**

The deliverability of renewable portfolio resources in the Northern California area is limited by thermal overloading of the Konocti - Eagle Rock 60 kV line under N-2 conditions as shown in Table F.8-14. This constraint was identified in baseline portfolio under HSN conditions. As shown in Table F.8-15, 53 MW of renewable and energy storage would be deliverable without any transmission upgrades. This constraint is a currently identified LDNU and will be addressed in GIP.

Table F.8-14: Konocti - Eagle Rock 60 kV line on-peak deliverability constraint

| Overloaded Facility       | Contingency                           | Scenario | Loading |       |
|---------------------------|---------------------------------------|----------|---------|-------|
|                           |                                       |          | HSN     | SSN   |
| Konocti - Eagle Rock 60kV | UKIAH-HOPLAND-CLOVERDALE 115KV [4050] | HSN      | 108.96% | <100% |

Table F.8-15: Konocti - Eagle Rock 60 kV line on-peak deliverability constraint summary

|   |                           |
|---|---------------------------|
| Affected transmission zones   | North of Greater Bay Area |
| Portfolio resources behind the constraint (Installed FCDS capacity)       | 191                       |
| Portfolio battery storage behind the constraint (Installed FCDS capacity) | 0                         |
| Deliverable portfolio resources w/o mitigation (Installed FCDS capacity)  | 53                        |

|  |                                     |   |
|--|-------------------------------------|---|
| Total undeliverable baseline and portfolio resources (Installed FCDS capacity) |                                     | 179   |
| Mitigation Options   | RAS                                 | N/A   |
|  | Reduce generic battery storage (MW) | N/A   |
|  | Transmission upgrade including cost | This constraint is a currently identified LDNU and will be addressed in GIP |
| Recommended Mitigation   |                                     | This constraint is a currently identified LDNU and will be addressed in GIP |

**F.8.2 2034 Off-peak results**

In the off-peak deliverability assessment of the North of Greater Bay interconnection no constraints were identified for the base portfolio.

**F.8.3 2039 On-peak results**

**Geyser # 12 - Fulton 230 kV (Fulton - Geyser#14 Jct) Line on-peak deliverability constraint**

The deliverability of renewable portfolio resources in the North of Greater Bay area is limited by thermal overloading of the Geyser # 12 - Fulton 230 kV (Fulton - Geyser#14 Jct) Line under N-2 conditions as shown Table F.8-16. This constraint was identified in baseline portfolio under sensitivity conditions. As shown in Table F.8-17, 61 MW of renewable and energy storage would be deliverable without any transmission upgrades. The CAISO will continue to monitor this constraint.

Table F.8-16: Geyser # 12 - Fulton 230 kV (Fulton - Geyser#14 Jct) Line on-peak deliverability constraint

| Overloaded Facility                                  | Contingency | Scenario | Loading |             |
|--|-------------|----------|---------|-------------|
|  |             |          | Base    | Sensitivity |
| Geyser # 12 - Fulton 230 kV (Fulton - Geyser#14 Jct) | Base Case   | HSN      | 101.99% | <100%       |

Table F.8-17: Geyser # 12 - Fulton 230 kV (Fulton - Geyser#14 Jct) Line on-peak deliverability constraint summary

|   |             |                    |
|---|-------------|--------------------|
| Affected transmission zones: PG&E North of Greater Bay Area |             |                    |
|   | <b>Base</b> | <b>Sensitivity</b> |

|  |                                     |                     |     |
|--|-------------------------------------|---------------------|-----|
| Generic Portfolio MW behind the constraint (installed FCDS capacity)                 |                                     | 60                  | N/A |
| Generic Battery storage portfolio MW behind the constraint (installed FCDS capacity) |                                     | 0                   | N/A |
| Deliverable Generic Portfolio MW w/o mitigation (Installed FCDS capacity)            |                                     | 61                  | N/A |
| Total undeliverable baseline and portfolio MW (Installed FCDS capacity)              |                                     | 2                   | N/A |
| Mitigation Options   | RAS                                 | N/A                 | N/A |
|  | Reduce generic battery storage (MW) | N/A                 | N/A |
|  | Transmission upgrade including cost | Continue to monitor | N/A |
| Recommended Mitigation   |                                     | Continue to monitor |     |

**Cortina - Vaca 230 kV Line on-peak deliverability constraint**

The deliverability of renewable portfolio resources in the North of Greater Bay area is limited by thermal overloading of the Cortina - Vaca 230 kV Line under N-2 conditions as shown Table F.8-18. This constraint was identified in the 2039 baseline portfolio only. As shown in Table F.8-19, 549 MW of renewable and energy storage would be deliverable without any transmission upgrades. The CAISO will continue to monitor this constraint.

Table F.8-18: Cortina - Vaca 230 kV Line on-peak deliverability constraint

| Overloaded Facility        | Contingency   | Scenario | Loading |             |
|----------------------------|---|----------|---------|-------------|
|                            |   |          | Base    | Sensitivity |
| Cortina - Vaca 230 kV Line | Delevan-Vaca Dixon No.2 230 kV Line & Delevan-Vaca Dixon No.3 230 kV Line | HSN      | 105.02% | 103.44%     |

Table F.8-19: Cortina - Vaca 230 kV Line on-peak deliverability constraint summary

| Affected transmission zones: PG&E North of Greater Bay Area                          |                                     |                     |             |
|--|-------------------------------------|---------------------|-------------|
|  |                                     | Base                | Sensitivity |
| Generic Portfolio MW behind the constraint (installed FCDS capacity)                 |                                     | 720                 | 706         |
| Generic Battery storage portfolio MW behind the constraint (installed FCDS capacity) |                                     | 0                   | 330         |
| Deliverable Generic Portfolio MW w/o mitigation (Installed FCDS capacity)            |                                     | 549                 | 680         |
| Total undeliverable baseline and portfolio MW (Installed FCDS capacity)              |                                     | 1224                | 1693        |
| Mitigation Options   | RAS                                 | N/A                 | N/A         |
|  | Reduce generic battery storage (MW) | N/A                 | N/A         |
|  | Transmission upgrade including cost | Continue to monitor | N/A         |



|                        |                     |
|------------------------|---------------------|
| Recommended Mitigation | Continue to monitor |
|------------------------|---------------------|

**Cortina - Mendocino No.1 115 kV (Mendocino Sub 115 kV to Lucerne Jct1 115 kV) Line on-peak deliverability constraint**

The deliverability of renewable portfolio resources in the North of Greater Bay area is limited by thermal overloading of the Cortina - Mendocino No.1 115 kV (Mendocino Sub 115 kV to Lucerne Jct1 115 kV) Line under N-2 conditions as shown Table F.8-20. As shown in Table F.8-21, 0 MW of renewable and energy storage would be deliverable without any transmission upgrades. The constraint is identified only in the sensitivity scenario.

Table F.8-20: Cortina - Mendocino No.1 115 kV (Mendocino Sub 115 kV to Lucerne Jct1 115 kV) Line on-peak deliverability constraint

| Overloaded Facility  | Contingency                                      | Scenario | Loading |             |
|--|--|----------|---------|-------------|
|  |  |          | Base    | Sensitivity |
| Cortina - Mendocino No.1 115 kV (Mendocino Sub 115kV to Lucerne Jct1 115 kv) | EAGLE ROCK-CORTINA & EAGLE ROCK-REDBUD LINES (2) | HSN      | <100%   | 110.75%     |

Table F.8-21: Cortina - Mendocino No.1 115 kV (Mendocino Sub 115 kV to Lucerne Jct1 115 kV) Line on-peak deliverability constraint summary

| Affected transmission zones: PG&E North of Greater Bay Area                          |                                     | Base                  | Sensitivity           |
|--|-------------------------------------|-----------------------|-----------------------|
| Generic Portfolio MW behind the constraint (installed FCDS capacity)                 |                                     | N/A                   | 81                    |
| Generic Battery storage portfolio MW behind the constraint (installed FCDS capacity) |                                     | N/A                   | 150                   |
| Deliverable Generic Portfolio MW w/o mitigation (Installed FCDS capacity)            |                                     | N/A                   | 0                     |
| Total undeliverable baseline and portfolio MW (Installed FCDS capacity)              |                                     | N/A                   | 347                   |
| Mitigation Options   | RAS                                 | N/A                   | N/A                   |
|  | Reduce generic battery storage (MW) | N/A                   | N/A                   |
|  | Transmission upgrade including cost | N/A                   | Mitigation not needed |
| Recommended Mitigation   |                                     | Mitigation not needed |                       |

**Lincoln - Pleasant Grove 115 kV Line on-peak deliverability constraint**

The deliverability of renewable portfolio resources in the North of Greater Bay area is limited by thermal overloading of the Lincoln - Pleasant Grove 115 kV Line under N-2 conditions as shown Table F.8-22. This constraint was identified in 2039 baseline portfolio and sensitivity conditions.

As shown in Table F.8-23, 0 MW of renewable and energy storage would be deliverable without any transmission upgrades. This constraint is a currently identified LDNU and will be addressed in GIP.

Table F.8-22: Lincoln - Pleasant Grove 115 kV Line on-peak deliverability constraint

| Overloaded Facility                  | Contingency  | Scenario | Loading |             |
|--------------------------------------|--|----------|---------|-------------|
|                                      |  |          | Base    | Sensitivity |
| Lincoln - Pleasant Grove 115 kV Line | Rio Oso-Atlantic 230 kV Line & Rio Oso-Gold Hill 230 kV Line | HSN      | 114.73% | 114.78%     |

Table F.8-23: Lincoln - Pleasant Grove 115 kV Line on-peak deliverability constraint summary

| Affected transmission zones: PG&E North of Greater Bay Area                          |                                     |   |   |
|--|-------------------------------------|---|---|
|  |                                     | Base  | Sensitivity   |
| Generic Portfolio MW behind the constraint (installed FCDS capacity)                 |                                     | 100   | 82  |
| Generic Battery storage portfolio MW behind the constraint (installed FCDS capacity) |                                     | 0   | 135   |
| Deliverable Generic Portfolio MW w/o mitigation (Installed FCDS capacity)            |                                     | 0   | 0   |
| Total undeliverable baseline and portfolio MW (Installed FCDS capacity)              |                                     | 459   | 539   |
| Mitigation Options   | RAS                                 | N/A   | N/A   |
|  | Reduce generic battery storage (MW) | N/A   | N/A   |
|  | Transmission upgrade including cost | This constraint is a currently identified LDNU and will be addressed in GIP | This constraint is a currently identified LDNU and will be addressed in GIP |
| Recommended Mitigation   |                                     | This constraint is a currently identified LDNU and will be addressed in GIP |   |

### F.8.4 Conclusion and recommendation

The PGE North of Greater Bay area base and sensitivity portfolios deliverability assessment identified on-peak deliverability constraints. The Eagle Rock- Fulton- Silverado 115 kV (Eagle rock sub to Ricon Jct Jct2 115 kV) line constraint is identified in 2034 on-peak scenario and the CAISO recommends reconductoring the line as mitigation.

## F.9 PG&E Greater Bay Interconnection Area

The total capacity of resources, by resource type, selected with Full Capacity Deliverability Status (FCDS) as well as those selected as Energy Only (EO) in the PG&E Greater Bay interconnection area are listed in Table F.9-1. The portfolios in the interconnection area are

comprised of solar, wind (in-state and offshore), battery storage, geothermal, biomass/biogas and distributed solar resources. All portfolio resources are modeled in policy-driven assessments except in the on-peak deliverability assessment in which only FCDS resources are modeled.

Table F.9-1: PG&E Greater Bay Interconnection Area –  
Base and Sensitivity Portfolios by Resource Types (FCDS, EO and Total)

| Resource Type                       | 2034 Base Portfolio |            |              | 2039 Base Portfolio |            |              | 2039 Sensitivity Portfolio |            |              |
|-------------------------------------|---------------------|------------|--------------|---------------------|------------|--------------|----------------------------|------------|--------------|
|                                     | FCDS (MW)           | EO (MW)    | Total (MW)   | FCDS (MW)           | EO (MW)    | Total (MW)   | FCDS (MW)                  | EO (MW)    | Total (MW)   |
| Solar                               | 0                   | 100        | 100          | 470                 | 215        | 685          | 670                        | 670        | 1,340        |
| Wind – In State                     | 688                 | 90         | 778          | 688                 | 90         | 778          | 698                        | 90         | 788          |
| Wind – Out-of-State                 | 0                   | 0          | 0            | 0                   | 0          | 0            | 0                          | 0          | 0            |
| Wind - Offshore                     | 0                   | 0          | 0            | 0                   | 0          | 0            | 0                          | 0          | 0            |
| Li Battery – 4 hr                   | 829                 | 0          | 829          | 879                 | 0          | 879          | 170                        | 0          | 170          |
| Li Battery – 8 hr                   | 212                 | 0          | 212          | 822                 | 0          | 822          | 1,645                      | 0          | 1,645        |
| Long Duration Energy Storage (LDES) | 0                   | 0          | 0            | 0                   | 0          | 0            | 0                          | 0          | 0            |
| Geothermal                          | 0                   | 0          | 0            | 0                   | 0          | 0            | 0                          | 0          | 0            |
| Biomass/Biogas                      | 26                  | 0          | 26           | 26                  | 0          | 26           | 5                          | 0          | 5            |
| Distributed Solar                   | 40                  | 0          | 40           | 40                  | 0          | 40           | 69                         | 0          | 69           |
| <b>Total</b>                        | <b>1,794</b>        | <b>190</b> | <b>1,984</b> | <b>2,924</b>        | <b>305</b> | <b>3,229</b> | <b>3,258</b>               | <b>760</b> | <b>4,018</b> |

The resources as identified in the CPUC busbar mapping for the PG&E Greater Bay interconnection area are illustrated on the single-line diagrams in Figure F.9-1 and Figure F.9-2. No adjustments were made to the portfolios in this area to account for allocated TPD and additional in-development resources identified.

Figure F.9-1: Greater Bay Interconnection Area – Mapped 2034 Base Portfolio

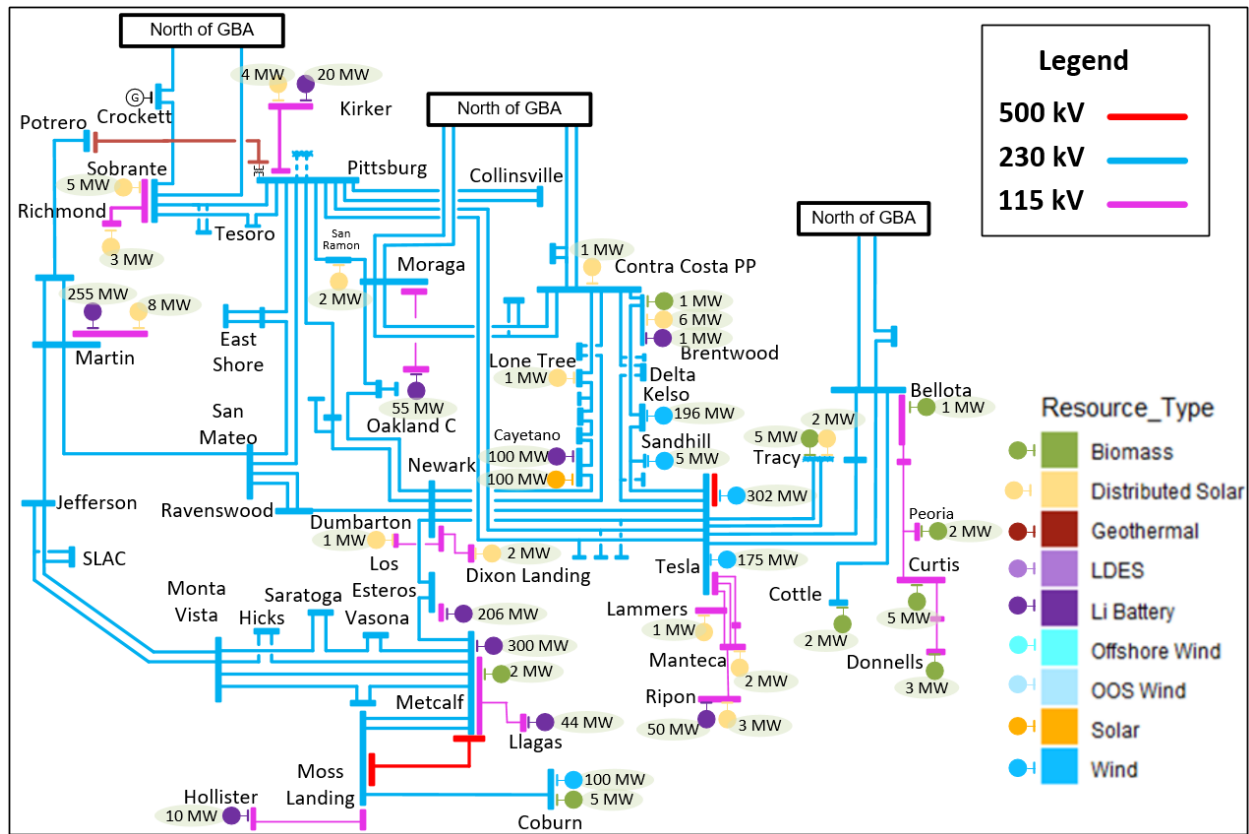
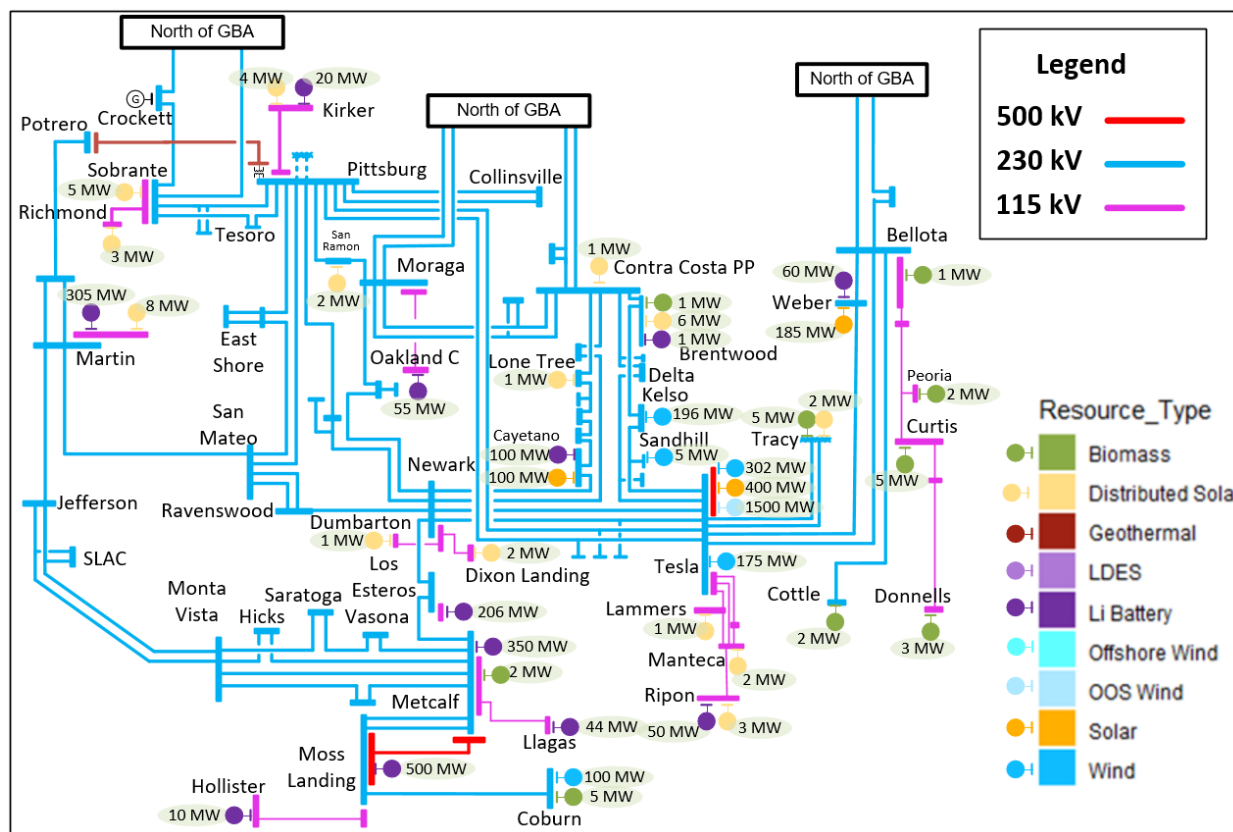

Figure F.9-2: Greater Bay Interconnection Area – Mapped 2039 Base Portfolio



With the resource mix specified in Table F.9-1 modeled in the base cases, the on-peak deliverability assessment identified the following constraints in PG&E study areas:

**F.9.1 2034 On-peak results**

**Eastshore-San Mateo 230 kV Line on-peak deliverability constraint**

The deliverability of renewable portfolio resources in the Northern California area is limited by thermal overloading of the Eastshore-San Mateo 230kV Line under N-2 conditions as shown in Table F.9-2. This constraint was identified with marginal overload in baseline portfolio under HSN conditions. As shown in Table F.9-3, 0 MW of renewable and energy storage would be deliverable without any transmission upgrades. The CAISO will continue to monitor this constraint.

Table F.9-2: Eastshore-San Mateo 230 kV Line on-peak deliverability constraint

| Overloaded Facility             | Contingency  | Scenario | Loading |       |
|---------------------------------|--|----------|---------|-------|
|                                 |  |          | HSN     | SSN   |
| Eastshore-San Mateo 230 kV Line | Newark-Ravenswood 230 kV and Tesla-Ravenswood 230 kV lines | HSN      | 100.09% | <100% |

Table F.9-3: Eastshore-San Mateo 230 kV Line on-peak deliverability constraint summary

|  |                                     |                     |
|--|-------------------------------------|---------------------|
| Affected transmission zones  |                                     | Greater Bay Area    |
| Portfolio resources behind the constraint (Installed FCDS capacity)            |                                     | 1                   |
| Portfolio battery storage behind the constraint (Installed FCDS capacity)      |                                     | 0                   |
| Deliverable portfolio resources w/o mitigation (Installed FCDS capacity)       |                                     | 0                   |
| Total undeliverable baseline and portfolio resources (Installed FCDS capacity) |                                     | 11                  |
| Mitigation Options   | RAS                                 | N/A                 |
|  | Reduce generic battery storage (MW) | N/A                 |
|  | Transmission upgrade including cost | N/A                 |
| Recommended Mitigation   |                                     | Continue to Monitor |

**Kifer-FMC 115 kV Line on-peak deliverability constraint**

The deliverability of renewable portfolio resources in the Northern California area is limited by thermal overloading of the Kifer-FMC 115 kV Line under N-2 conditions as shown in Table F.9-4. This constraint was identified in baseline portfolio under HSN conditions. As shown in Table F.9-5, 299 MW of renewable and energy storage would be deliverable without any transmission upgrades. The constraint can be mitigated by reducing portfolio BESS.

Table F.9-4: Kifer-FMC 115 kV Line deliverability constraint

| Overloaded Facility   | Contingency   | Scenario | Loading |       |
|-----------------------|---|----------|---------|-------|
|                       |   |          | HSN     | SSN   |
| Kifer-FMC 115 kV Line | Newark - Los Esteros & Los Esteros - Metcalf 230 KV Lines | HSN      | 103.41% | <100% |

Table F.9-5: Kifer-FMC 115 kV Line on-peak deliverability constraint summary

|  |                                     |                  |
|--|-------------------------------------|------------------|
| Affected transmission zones  |                                     | Greater Bay Area |
| Portfolio resources behind the constraint (Installed FCDS capacity)            |                                     | 2                |
| Portfolio battery storage behind the constraint (Installed FCDS capacity)      |                                     | 376              |
| Deliverable portfolio resources w/o mitigation (Installed FCDS capacity)       |                                     | 299              |
| Total undeliverable baseline and portfolio resources (Installed FCDS capacity) |                                     | 149              |
| Mitigation Options   | RAS                                 | N/A              |
|  | Reduce generic battery storage (MW) | N/A              |
|  | Transmission upgrade including cost | N/A              |

|                        |                       |
|------------------------|-----------------------|
| Recommended Mitigation | Reduce Portfolio BESS |
|------------------------|-----------------------|

**Metcalfe-EI Patio No. 2 115 kV Line on-peak deliverability constraint**

The deliverability of renewable portfolio resources in the Northern California area is limited by thermal overloading of the Metcalfe-EI Patio No. 2 115 kV Line under N-1 conditions as shown in Table F.9-6. This constraint was identified with a marginal overload in baseline portfolio under HSN conditions. As shown in Table F.9-7, 240 MW of renewable and energy storage would be deliverable without any transmission upgrades. The constraint can be mitigated by reducing portfolio BESS.

Table F.9-6: Metcalfe-EI Patio No. 2 115 kV Line deliverability constraint

| Overloaded Facility                 | Contingency                         | Scenario | Loading |       |
|-------------------------------------|-------------------------------------|----------|---------|-------|
|                                     |                                     |          | HSN     | SSN   |
| Metcalfe-EI Patio No. 2 115 kV Line | SANJOSEBHVDC-SANJOSEB #1 115 KV [0] | HSN      | 100.86% | <100% |

Table F.9-7: Metcalfe-EI Patio No. 2 115 kV Line on-peak deliverability constraint summary

|  |                                     |                       |
|--|-------------------------------------|-----------------------|
| Affected transmission zones  |                                     | Greater Bay Area      |
| Portfolio resources behind the constraint (Installed FCDS capacity)            |                                     | 0                     |
| Portfolio battery storage behind the constraint (Installed FCDS capacity)      |                                     | 300                   |
| Deliverable portfolio resources w/o mitigation (Installed FCDS capacity)       |                                     | 240                   |
| Total undeliverable baseline and portfolio resources (Installed FCDS capacity) |                                     | 60                    |
| Mitigation Options   | RAS                                 | N/A                   |
|  | Reduce generic battery storage (MW) | N/A                   |
|  | Transmission upgrade including cost | N/A                   |
| Recommended Mitigation   |                                     | Reduce Portfolio BESS |

**Ripon - Ripon Jct 115 kV Line on-peak deliverability constraint**

The deliverability of renewable portfolio resources in the Northern California area is limited by thermal overloading of the Ripon - Ripon Jct 115 kV Line under base case conditions as shown in Table F.9-8. This constraint was identified in baseline portfolio under HSN conditions. As shown in Table F.9-9, 48 MW of renewable and energy storage would be deliverable without any transmission upgrades. The constraint can be mitigated by reducing portfolio BESS.

Table F.9-8: Ripon - Ripon Jct 115 kV Line deliverability constraint

| Overloaded Facility           | Contingency | Scenario | Loading |       |
|-------------------------------|-------------|----------|---------|-------|
|                               |             |          | HSN     | SSN   |
| Ripon - Ripon Jct 115 kV Line | Base Case   | HSN      | 104.98% | <100% |

Table F.9-9: Ripon - Ripon Jct 115 kV Line on-peak deliverability constraint summary

|  |                                     |                       |
|--|-------------------------------------|-----------------------|
| Affected transmission zones  |                                     | Greater Bay Area      |
| Portfolio resources behind the constraint (Installed FCDS capacity)            |                                     | 3                     |
| Portfolio battery storage behind the constraint (Installed FCDS capacity)      |                                     | 50                    |
| Deliverable portfolio resources w/o mitigation (Installed FCDS capacity)       |                                     | 48                    |
| Total undeliverable baseline and portfolio resources (Installed FCDS capacity) |                                     | 5                     |
| Mitigation Options   | RAS                                 | N/A                   |
|  | Reduce generic battery storage (MW) | N/A                   |
|  | Transmission upgrade including cost | N/A                   |
| Recommended Mitigation   |                                     | Reduce Portfolio BESS |

**Tesla - Westley 230 kV Line on-peak deliverability constraint**

The deliverability of renewable portfolio resources in the Northern California area is limited by thermal overloading of the Tesla - Westley 230 kV Line under N-1 conditions as shown in Table F.9-10. This constraint was identified in baseline portfolio under HSN conditions. As shown in Table F.9-11, 159 MW of renewable and energy storage would be deliverable without any transmission upgrades. The constraint will be addressed by the reliability project in Greater Bay Area.

Table F.9-10: Tesla - Westley 230 kV Line deliverability constraint

| Overloaded Facility         | Contingency          | Scenario | Loading |       |
|-----------------------------|----------------------|----------|---------|-------|
|                             |                      |          | HSN     | SSN   |
| Tesla - Westley 230 kV Line | TESLA 500/230KV TB 2 | HSN      | 106.8%  | <100% |



Table F.9-11: Tesla - Westley 230 kV Line on-peak deliverability constraint summary

|  |                                     |   |
|--|-------------------------------------|---|
| Affected transmission zones  |                                     | Greater Bay Area                        |
| Portfolio resources behind the constraint (Installed FCDS capacity)            |                                     | 1099                                    |
| Portfolio battery storage behind the constraint (Installed FCDS capacity)      |                                     | 201                                     |
| Deliverable portfolio resources w/o mitigation (Installed FCDS capacity)       |                                     | 159                                     |
| Total undeliverable baseline and portfolio resources (Installed FCDS capacity) |                                     | 1901                                    |
| Mitigation Options   | RAS                                 | N/A                                     |
|  | Reduce generic battery storage (MW) | N/A                                     |
|  | Transmission upgrade including cost | N/A                                     |
| Recommended Mitigation   |                                     | Reliability project in Greater Bay Area |

Table F.9-12 lists constraints identified only in the SSN scenario. These are provided for informative purposes and mitigation is not required for this scenario.

Table F.9-12: Deliverability constraints identified only in SSN scenario.

| Constraint                     | Contingency  | Loading | Renewable Portfolio MW behind Constraint | Energy Storage Portfolio MW behind Constraint | Deliverable Portfolio MW without mitigation | Potential Mitigation                       |
|--------------------------------|--|---------|--|---|---|--|
| Manteca - Vierra 115 kV Lin    | SCHULTE SW STA-KASSON-MANTECA 115KV [7472] & TESLA-SALADO-MANTECA 115KV [4000] | 124.47% | 1  | 0   | 0   | Local constraint. Will be addressed in GIP |
| San Jose - Trimble 115 kV Line | FMC-SAN JOSE B 115KV [2021]  | 116.97% | 2  | 420   | 0   | SSN only, No mitigation required           |
| Melones - Cottle 230 kV Line   | WARNERVILLE-WILSON 230KV [5870]  | 112.83% | 455                                      | 0   | 0   | SSN only, No mitigation required           |

### F.9.2 2034 Off-peak results

In the off-peak deliverability assessment of the Greater Bay interconnection there was one constraint identified for the base portfolio. The constraint observed is listed in Table F.9-13.

Table F.9-13: Greater Bay Interconnection Area Off-Peak Deliverability Constraints

| Constraint                            | Contingency          | Loading | Renewable Portfolio MW behind Constraint | Energy Storage Portfolio MW behind Constraint | Renewable curtailment without mitigation | Potential Mitigation    |
|---------------------------------------|----------------------|---------|--|---|--|-------------------------|
| Trimble - San Jose B - DG 115 kV line | FMC-SAN JOSE B 115KV | 122.07  | 1.8                                      | 344   | 344                                      | Reconductor if economic |

Critical constraints identified in off peak study have been evaluated as part of the economic study. For mitigation please refer to the economic study process.

**F.9.3 2039 On-peak results**

**El Patio-San Jose Sta. 'A' 115 kV Line on-peak deliverability constraint**

The deliverability of renewable portfolio resources in the Greater Bay area is limited by thermal overloading of the El Patio-San Jose Sta. 'A' 115 kV Line under N-2 conditions as shown Table F.9-14. This constraint was identified in baseline portfolio under sensitivity conditions. As shown in Table F.9-15, 0 MW of renewable and energy storage would be deliverable without any transmission upgrades. No mitigation proposed since it's identified only in the sensitivity scenario.

Table F.9-14: El Patio-San Jose Sta. 'A' 115 kV Line on-peak deliverability constraint

| Overloaded Facility                    | Contingency                                | Scenario | Loading |             |
|--|--|----------|---------|-------------|
|  |  |          | Base    | Sensitivity |
| El Patio-San Jose Sta. 'A' 115 kV Line | Metcalf - Evergreen #1 and #2 115 KV Lines | HSN      | <100%   | 117.85%     |

Table F.9-15: El Patio-San Jose Sta. 'A' 115 kV Line on-peak deliverability constraint summary

| Affected transmission zones: PG&E Greater Bay Area                                   |                                     |                  |             |
|--|-------------------------------------|------------------|-------------|
|  |                                     | Base             | Sensitivity |
| Generic Portfolio MW behind the constraint (installed FCDS capacity)                 |                                     | N/A              | 0           |
| Generic Battery storage portfolio MW behind the constraint (installed FCDS capacity) |                                     | N/A              | 470         |
| Deliverable Generic Portfolio MW w/o mitigation (Installed FCDS capacity)            |                                     | N/A              | 0           |
| Total undeliverable baseline and portfolio MW (Installed FCDS capacity)              |                                     | N/A              | 683         |
| Mitigation Options   | RAS                                 | N/A              | N/A         |
|  | Reduce generic battery storage (MW) | N/A              | N/A         |
|  | Transmission upgrade including cost | N/A              | N/A         |
| Recommended Mitigation   |                                     | Sensitivity only |             |

**Los Esteros - Nortech 115 kV line on-peak deliverability constraint**

The deliverability of renewable portfolio resources in the Greater Bay area is limited by thermal overloading of the Los Esteros - Nortech 115 kV line under N-1 conditions as shown Table F.9-16. This constraint was identified in baseline portfolio under HSN conditions. As shown in Table F.9-17, 0 MW of renewable and energy storage would be deliverable without any transmission upgrades. No mitigation proposed since it's identified only in the sensitivity scenario.

Table F.9-16: Los Esteros - Nortech 115 kV line on-peak deliverability constraint

| Overloaded Facility               | Contingency                  | Scenario | Loading |             |
|-----------------------------------|------------------------------|----------|---------|-------------|
|                                   |                              |          | Base    | Sensitivity |
| Los Esteros - Nortech 115 kV line | SSS-NRSriser SVP 230 kV path | HSN      | 127.22% | 127.56%     |

Table F.9-17: Los Esteros - Nortech 115 kV line on-peak deliverability constraint summary

| Affected transmission zones: PG&E Greater Bay Area                                   |                                     |   |             |
|--|-------------------------------------|---|-------------|
|  |                                     | Base                                    | Sensitivity |
| Generic Portfolio MW behind the constraint (installed FCDS capacity)                 |                                     | N/A                                     | 0           |
| Generic Battery storage portfolio MW behind the constraint (installed FCDS capacity) |                                     | N/A                                     | 206         |
| Deliverable Generic Portfolio MW w/o mitigation (Installed FCDS capacity)            |                                     | N/A                                     | 0           |
| Total undeliverable baseline and portfolio MW (Installed FCDS capacity)              |                                     | N/A                                     | 479         |
| Mitigation Options   | RAS                                 | N/A                                     | N/A         |
|  | Reduce generic battery storage (MW) | N/A                                     | N/A         |
|  | Transmission upgrade including cost | N/A                                     | N/A         |
| Recommended Mitigation   |                                     | Mitigation not needed, sensitivity only |             |

**Manteca - Vierra 115 kV Line on-peak deliverability constraint**

The deliverability of renewable portfolio resources in the Greater Bay area is limited by thermal overloading of the Manteca - Vierra 115 kV Line under N-2 conditions as shown Table F.9-18. This constraint was identified in baseline portfolio under HSN conditions. As shown in Table F.9-19, 0 MW of renewable and energy storage would be deliverable without any transmission upgrades. This is a local constraint and will be addressed in GIP.

Table F.9-18: Manteca - Vierra 115 kV Line on-peak deliverability constraint

| Overloaded Facility          | Contingency  | Scenario | Loading |             |
|------------------------------|--|----------|---------|-------------|
|                              |  |          | Base    | Sensitivity |
| Manteca - Vierra 115 kV Line | SCHULTE SW STA-KASSON-MANTECA 115KV [7472] & TESLA-SALADO-MANTECA 115KV [4000] | HSN      | 111.98% | <100%       |

Table F.9-19: Manteca - Vierra 115 kV Line on-peak deliverability constraint summary

| Affected transmission zones: PG&E Greater Bay Area                                   |                                     |  |             |
|--|-------------------------------------|--|-------------|
|  |                                     | Base                                       | Sensitivity |
| Generic Portfolio MW behind the constraint (installed FCDS capacity)                 |                                     | 1  | N/A         |
| Generic Battery storage portfolio MW behind the constraint (installed FCDS capacity) |                                     | 0  | N/A         |
| Deliverable Generic Portfolio MW w/o mitigation (Installed FCDS capacity)            |                                     | 0  | N/A         |
| Total undeliverable baseline and portfolio MW (Installed FCDS capacity)              |                                     | 186  | N/A         |
| Mitigation Options   | RAS                                 | N/A  | N/A         |
|  | Reduce generic battery storage (MW) | N/A  | N/A         |
|  | Transmission upgrade including cost | Local constraint. Will be addressed in GIP | N/A         |
| Recommended Mitigation   |                                     | Local constraint. Will be addressed in GIP |             |

**Bellota - Lockford 230 kV Line on-peak deliverability constraint**

The deliverability of renewable portfolio resources in the Greater Bay area is limited by thermal overloading of the Bellota - Lockford 230 kV Line under N-1 conditions as shown Table F.9-20. This constraint was identified in baseline portfolio under HSN conditions. As shown in Table F.9-21, 362 MW of renewable and energy storage would be deliverable without any transmission upgrades. This is a local constraint and will be addressed in GIP.

Table F.9-20: Bellota - Lockford 230 kV Line on-peak deliverability constraint

| Overloaded Facility            | Contingency                    | Scenario | Loading |             |
|--------------------------------|--------------------------------|----------|---------|-------------|
|                                |                                |          | Base    | Sensitivity |
| Bellota - Lockford 230 kV Line | LOCKEFORD-BELLOTA 230KV [4990] | HSN      | 106.39% | 133.36%     |

Table F.9-21: Bellota - Lockford 230 kV Line on-peak deliverability constraint summary

| Affected transmission zones: PG&E Greater Bay Area                                   |  |      |             |
|--|--|------|-------------|
|  |  | Base | Sensitivity |
| Generic Portfolio MW behind the constraint (installed FCDS capacity)                 |  | 253  | 244         |
| Generic Battery storage portfolio MW behind the constraint (installed FCDS capacity) |  | 0    | 228         |
| Deliverable Generic Portfolio MW w/o mitigation (Installed FCDS capacity)            |  | 0    | 362         |
| Total undeliverable baseline and portfolio MW (Installed FCDS capacity)              |  | 861  | 762         |

|                        |                                     |  |  |
|------------------------|-------------------------------------|--|--|
| Mitigation Options     | RAS                                 | N/A  | N/A  |
|                        | Reduce generic battery storage (MW) | N/A  | N/A  |
|                        | Transmission upgrade including cost | Local constraint. Will be addressed in GIP | Local constraint. Will be addressed in GIP |
| Recommended Mitigation |                                     | Local constraint. Will be addressed in GIP |  |

**Newark-Northern Receiving Station #1 115 kV Line on-peak deliverability constraint**

The deliverability of renewable portfolio resources in the Greater Bay area is limited by thermal overloading of the Newark-Northern Receiving Station #1 115kV Line under N-2 conditions as shown Table F.9-22. This constraint was identified in baseline portfolio under HSN conditions. As shown in Table F.9-23, 0 MW of renewable and energy storage would be deliverable without any transmission upgrades. No mitigation proposed since it's identified only in the sensitivity scenario.

Table F.9-22: Newark-Northern Receiving Station #1 115 kV Line on-peak deliverability constraint

| Overloaded Facility                             | Contingency   | Scenario | Loading |             |
|---|---|----------|---------|-------------|
|   |   |          | Base    | Sensitivity |
| Newark-Northern Receiving Station #1 115kV Line | Newark - Los Esteros & Los Esteros - Metcalf 230 KV Lines | HSN      | <100%   | 103.41%     |

Table F.9-23: Newark-Northern Receiving Station #1 115 kV Line on-peak deliverability constraint summary

| Affected transmission zones: PG&E Greater Bay Area                                   |                                     |                  |             |
|--|-------------------------------------|------------------|-------------|
|  |                                     | Base             | Sensitivity |
| Generic Portfolio MW behind the constraint (installed FCDS capacity)                 |                                     | N/A              | 1           |
| Generic Battery storage portfolio MW behind the constraint (installed FCDS capacity) |                                     | N/A              | 0           |
| Deliverable Generic Portfolio MW w/o mitigation (Installed FCDS capacity)            |                                     | N/A              | 0           |
| Total undeliverable baseline and portfolio MW (Installed FCDS capacity)              |                                     | N/A              | 115         |
| Mitigation Options   | RAS                                 | N/A              | N/A         |
|  | Reduce generic battery storage (MW) | N/A              | N/A         |
|  | Transmission upgrade including cost | N/A              | N/A         |
| Recommended Mitigation   |                                     | Sensitivity only |             |

**San Jose Sta 'A'-'B' 115 kV Line on-peak deliverability constraint**

The deliverability of renewable portfolio resources in the Greater Bay area is limited by thermal overloading of the San Jose Sta 'A'-'B' 115 kV Line under N-2 conditions as shown Table F.9-24. This constraint was identified in baseline portfolio under HSN conditions. As shown in Table F.9-25, 0 MW of renewable and energy storage would be deliverable without any transmission upgrades. No mitigation proposed since it's identified only in the sensitivity scenario.

Table F.9-24: San Jose Sta 'A'-'B' 115 kV Line on-peak deliverability constraint

| Overloaded Facility              | Contingency                                | Scenario | Loading |             |
|----------------------------------|--|----------|---------|-------------|
|                                  |  |          | Base    | Sensitivity |
| San Jose Sta 'A'-'B' 115 kV Line | Metcalf - Evergreen #1 and #2 115 KV Lines | HSN      | <100%   | 116.69%     |

Table F.9-25: San Jose Sta 'A'-'B' 115 kV Line on-peak deliverability constraint summary

| Affected transmission zones: PG&E Greater Bay Area                                   |                                     |                  |             |
|--|-------------------------------------|------------------|-------------|
|  |                                     | Base             | Sensitivity |
| Generic Portfolio MW behind the constraint (installed FCDS capacity)                 |                                     | N/A              | 0           |
| Generic Battery storage portfolio MW behind the constraint (installed FCDS capacity) |                                     | N/A              | 470         |
| Deliverable Generic Portfolio MW w/o mitigation (Installed FCDS capacity)            |                                     | N/A              | 0           |
| Total undeliverable baseline and portfolio MW (Installed FCDS capacity)              |                                     | N/A              | 560         |
| Mitigation Options   | RAS                                 | N/A              | N/A         |
|  | Reduce generic battery storage (MW) | N/A              | N/A         |
|  | Transmission upgrade including cost | N/A              | N/A         |
| Recommended Mitigation   |                                     | Sensitivity only |             |

**F.9.4 Conclusion and recommendation**

The PGE Greater Bay area base and sensitivity portfolio deliverability assessment identified on-peak and off-peak deliverability constraints. These constraints are provided for informative purposes and do not require mitigation. These constraints will be mitigated through the GIP track or through projects that are already approved. No new mitigation is identified.

**F.10 PG&E Greater Fresno Interconnection Area**

The total capacity of resources, by resource type, selected with Full Capacity Deliverability Status (FCDS) as well as those selected as Energy Only (EO) in the PG&E Greater Fresno

interconnection area are listed in Table F.10-1. The portfolios are comprised of solar, wind (in-state), battery storage, biomass/biogas and distributed solar resources. All portfolio resources are modeled in policy-driven assessments except in the on-peak deliverability assessment in which only FCDS resources are modeled.

Table F.10-1: PG&E Greater Fresno Interconnection Area – Base and Sensitivity Portfolios by Resource Types (FCDS, EO and Total)

| Resource Type                       | 2034 Base Portfolio |            |              | 2039 Base Portfolio |              |               | 2039 Sensitivity Portfolio |              |               |
|-------------------------------------|---------------------|------------|--------------|---------------------|--------------|---------------|----------------------------|--------------|---------------|
|                                     | FCDS (MW)           | EO (MW)    | Total (MW)   | FCDS (MW)           | EO (MW)      | Total (MW)    | FCDS (MW)                  | EO (MW)      | Total (MW)    |
| Solar                               | 2,636               | 869        | 3,505        | 3,027               | 3,404        | 6,430         | 5,338                      | 5,823        | 11,160        |
| Wind – In State                     | 394                 | 96         | 490          | 394                 | 96           | 490           | 360                        | 40           | 400           |
| Wind – Out-of-State                 | 0                   | 0          | 0            | 0                   | 0            | 0             | 0                          | 0            | 0             |
| Wind - Offshore                     | 0                   | 0          | 0            | 0                   | 0            | 0             | 0                          | 0            | 0             |
| Li Battery – 4 hr                   | 1,554               | 0          | 1,554        | 1,669               | 0            | 1,669         | 1,455                      | 0            | 1,455         |
| Li Battery – 8 hr                   | 200                 | 0          | 200          | 1,607               | 0            | 1,607         | 2,780                      | 0            | 2,780         |
| Long Duration Energy Storage (LDES) | 130                 | 0          | 130          | 130                 | 0            | 130           | 131                        | 0            | 131           |
| Geothermal                          | 0                   | 0          | 0            | 0                   | 0            | 0             | 0                          | 0            | 0             |
| Biomass/Biogas                      | 20                  | 0          | 20           | 20                  | 0            | 20            | 3                          | 0            | 3             |
| Distributed Solar                   | 66                  | 0          | 66           | 66                  | 0            | 66            | 68                         | 0            | 68            |
| <b>Total</b>                        | <b>5,001</b>        | <b>965</b> | <b>5,966</b> | <b>6,913</b>        | <b>3,500</b> | <b>10,412</b> | <b>10,134</b>              | <b>5,863</b> | <b>15,997</b> |

The resources as identified in the CPUC busbar mapping for the PG&E Greater Fresno interconnection area are illustrated on the single-line diagrams in Figure F.10-1 and F.10-2. No adjustments were made to the portfolios in this area to account for allocated TPD and additional in-development resources identified.



Figure F.10-1: PG&E Greater Fresno Interconnection Area – Mapped 2034 Base Portfolio

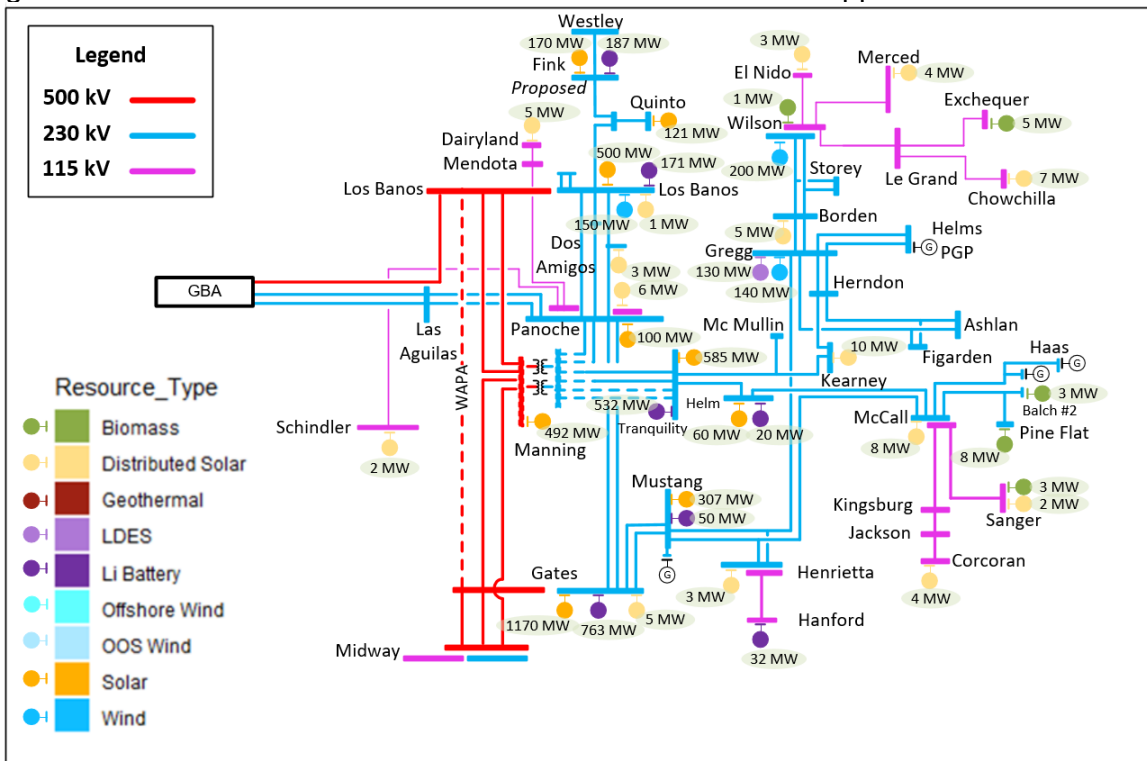
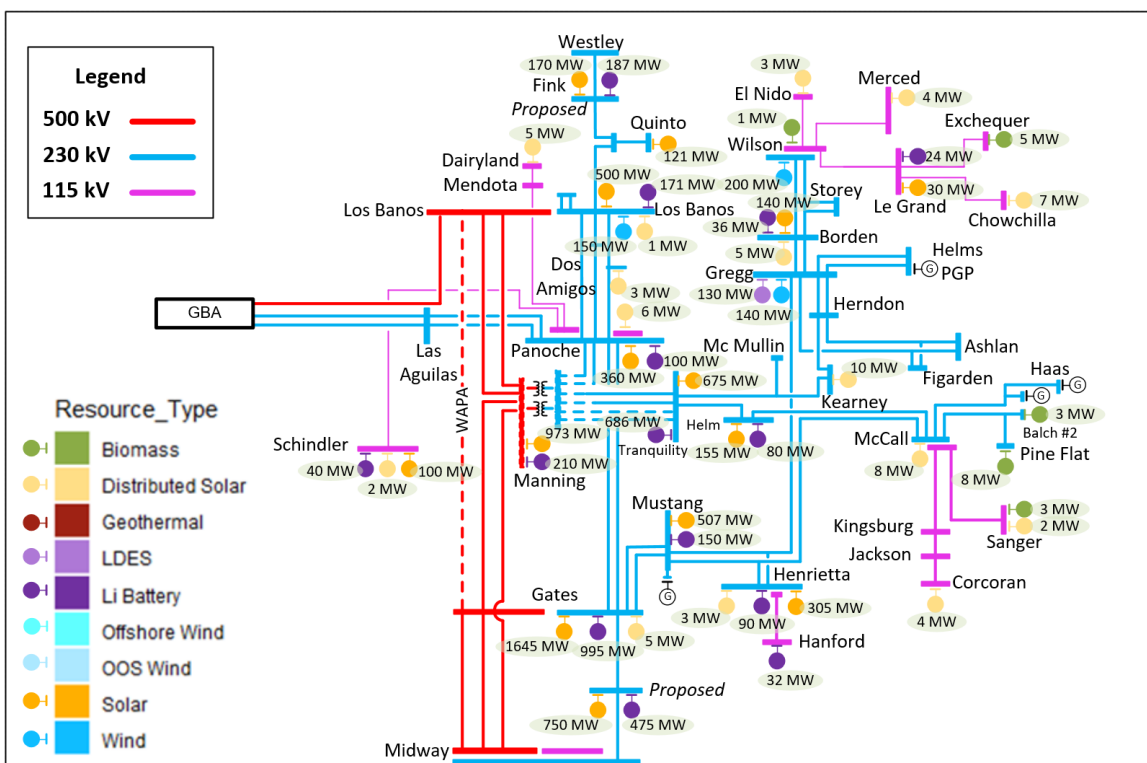

Figure F.10-2: PG&E Greater Fresno Interconnection Area – Mapped 2039 Base Portfolio



**F.10.1 2034 On-peak results**

**GWF-Kingsburg 115 kV Line on-peak deliverability constraint**

The deliverability of renewable portfolio resources in the Greater Fresno area is limited by thermal overloading of the GWF-Kingsburg 115 kV Line under N-2 conditions as shown in Table F.10-2. This constraint was identified in baseline portfolio under HSN conditions. As shown in Table F.10-3, 314 MW of renewable and energy storage would be deliverable without any transmission upgrades. The constraint would be mitigated by reconductoring the GWF-Kingsburg 115 kV Line.

Table F.10-2: GWF-Kingsburg 115 kV Line on-peak deliverability constraint

| Overloaded Facility       | Contingency                                    | Scenario | Loading |       |
|---------------------------|--|----------|---------|-------|
|                           |  |          | HSN     | SSN   |
| GWF-Kingsburg 115 kV Line | HELM-MCCALL 230KV & HENTAP2-MUSTANGSS #1 230KV | HSN      | 122.18% | <100% |

Table F.10-3: GWF-Kingsburg 115 kV Line on-peak deliverability constraint summary

|  |  |                       |
|--|--|-----------------------|
| Affected transmission zones: PG&E Fresno Area  |  |                       |
|  |  | <b>Base</b>           |
| Generic Portfolio MW behind the constraint (installed FCDS capacity)                 |  | 314                   |
| Generic Battery storage portfolio MW behind the constraint (installed FCDS capacity) |  | 32                    |
| Deliverable Generic Portfolio MW w/o mitigation (Installed FCDS capacity)            |  | 314                   |
| Total undeliverable baseline and portfolio MW (Installed FCDS capacity)              |  | 127                   |
| Mitigation Options   | RAS  | N/A                   |
|  | Re-locate generic portfolio battery storage (MW) | N/A                   |
|  | Transmission upgrade including cost              | Reconductor (\$81.6M) |
| Recommended Mitigation   |  | Reconductor           |

**Reconductor of GWF – Kingsburg 115 kV line**

To mitigate overloads identified in the on-peak baseline deliverability study, the ISO is recommending for approval the reconductor of the GWF – Kingsburg 115kV line. The Project will cost \$81.6M, with an estimated time to construct of 36 months. The scope includes Reconductor the entire GWF-Kingsburg 115 kV Line with minimum summer emergency rating of 1500 Amps or higher and update the limiting components at the substations if there is any.

Figure F.10-3: Reconductor of GWF-Kingsburg 115 kV Line

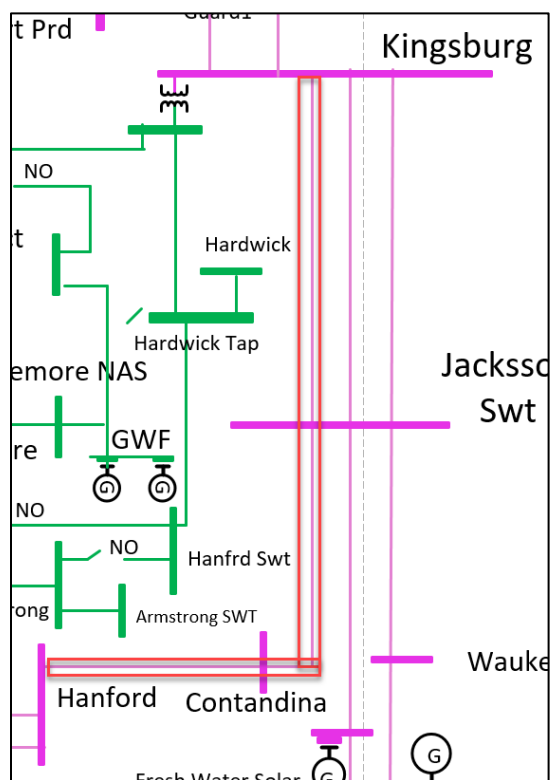

**Herndon-Woodward 115 kV Line on-peak deliverability constraint**

The deliverability of renewable portfolio resources in the Fresno area is limited by thermal overloading of the Herndon-Woodward 115 kV Line under N-2 conditions as shown in Table F.10-4. This constraint was identified in baseline portfolio under HSN conditions. As shown in Table F.10-5, 0 MW of renewable and energy storage would be deliverable without any transmission upgrades. This is a local constraint and will be addressed in GIP.

Table F.10-4: Herndon-Woodward 115 kV Line on-peak deliverability constraint

| Overloaded Facility          | Contingency                                     | Scenario | Loading |       |
|------------------------------|---|----------|---------|-------|
|                              |   |          | HSN     | SSN   |
| Herndon-Woodward 115 kV Line | HERNDON-BARTON 115KV & HERNDON-MANCHESTER 115KV | HSN      | 120.15% | <100% |

Table F.10-5: Herndon-Woodward 115 kV Line on-peak deliverability constraint summary

|   |      |
|---|------|
| Affected transmission zones: PG&E Fresno Area |      |
|   | Base |

|  |  |  |
|--|--|--|
| Generic Portfolio MW behind the constraint (installed FCDS capacity)                 |  | 240  |
| Generic Battery storage portfolio MW behind the constraint (installed FCDS capacity) |  | 0  |
| Deliverable Generic Portfolio MW w/o mitigation (Installed FCDS capacity)            |  | 0  |
| Total undeliverable baseline and portfolio MW (Installed FCDS capacity)              |  | 566  |
| Mitigation Options   | RAS  | N/A  |
|  | Re-locate generic portfolio battery storage (MW) | N/A  |
|  | Transmission upgrade including cost              | N/A  |
| Recommended Mitigation   |  | Local constraint, will be addressed in GIP |

**McCall-Sanger #3 115 kV Line on-peak deliverability constraint**

The deliverability of renewable portfolio resources in the Fresno area is limited by thermal overloading of the McCall-Sanger #3 115 kV Line under N-2 conditions as shown Table F.10-6. This constraint was identified in baseline portfolio under HSN conditions. As shown in Table F.10-7, 0 MW of renewable and energy storage would be deliverable without any transmission upgrades. This is a local constraint and will be addressed in GIP.

Table F.10-6: McCall-Sanger #3 115 kV Line on-peak deliverability constraint

| Overloaded Facility          | Contingency                                     | Scenario | Loading |       |
|------------------------------|---|----------|---------|-------|
|                              |   |          | HSN     | SSN   |
| McCall-Sanger #3 115 kV Line | MCCALL-SANGER #1 115KV & MCCALL-SANGER #2 115KV | HSN      | 113.11% | <100% |

Table F.10-7: McCall-Sanger #3 115 kV Line on-peak deliverability constraint summary

|  |  |             |
|--|--|-------------|
| Affected transmission zones: PG&E Fresno Area  |  |             |
|  |  | <b>Base</b> |
| Generic Portfolio MW behind the constraint (installed FCDS capacity)                 |  | 21          |
| Generic Battery storage portfolio MW behind the constraint (installed FCDS capacity) |  | 32          |
| Deliverable Generic Portfolio MW w/o mitigation (Installed FCDS capacity)            |  | 0           |
| Total undeliverable baseline and portfolio MW (Installed FCDS capacity)              |  | 316         |
| Mitigation Options   | RAS  | N/A         |
|  | Re-locate generic portfolio battery storage (MW) | N/A         |
|  | Transmission upgrade including cost              | N/A         |

|                        |   |
|------------------------|---|
| Recommended Mitigation | constraint meets LDNU criteria and will be addressed in GIP |
|------------------------|---|

**Helm-Crescent 70 kV Line on-peak deliverability constraint**

The deliverability of renewable portfolio resources in the Fresno area is limited by thermal overloading of the Helm-Crescent 70 kV Line under N-1 conditions as shown Table F.10-8. This constraint was identified in baseline portfolio under HSN conditions. As shown in Table F.10-9, 184 MW of renewable and energy storage would be deliverable without any transmission upgrades. The constraint would be mitigated by installing a new Helm 230/70kV Bank #2.

Table F.10-8: Helm-Crescent 70 kV Line on-peak deliverability constraint

| Overloaded Facility      | Contingency        | Scenario | Loading |         |
|--------------------------|--------------------|----------|---------|---------|
|                          |                    |          | HSN     | SSN     |
| Helm-Crescent 70 kV Line | HELM 230/70KV TB 1 | HSN      | 280.2%  | 511.12% |

Table F.10-9: Helm-Crescent 70 kV Line on-peak deliverability constraint summary

|  |  |  |
|--|--|--|
| Affected transmission zones: PG&E Fresno Area  |  |  |
|  |  | <b>Base</b>                                |
| Generic Portfolio MW behind the constraint (installed FCDS capacity)                 |  | 200  |
| Generic Battery storage portfolio MW behind the constraint (installed FCDS capacity) |  | 81   |
| Deliverable Generic Portfolio MW w/o mitigation (Installed FCDS capacity)            |  | 184  |
| Total undeliverable baseline and portfolio MW (Installed FCDS capacity)              |  | 97   |
| Mitigation Options   | RAS  | N/A  |
|  | Re-locate generic portfolio battery storage (MW) | N/A  |
|  | Transmission upgrade including cost              | Install new Helm 230/70kV Bank #2 (\$115M) |
| Recommended Mitigation   |  | Install new Helm 230/70kV Bank #2          |

**New Helm 230/70 kV Bank #2**

To mitigate overloads identified in the on-peak baseline deliverability study, the ISO is recommending for approval the addition of a new 230/70 kV bank at Helm. The Project will cost \$115M, with an estimated time to construct of 48-60 months. The scope includes a new 230/70

kV Bank at Helm Substation with a 200 MVA rating. It will also include any bus upgrades and limiting equipment upgrades to achieve this transformer rating.

Figure F.10-4: New Helm 230/70 kV Bank #2

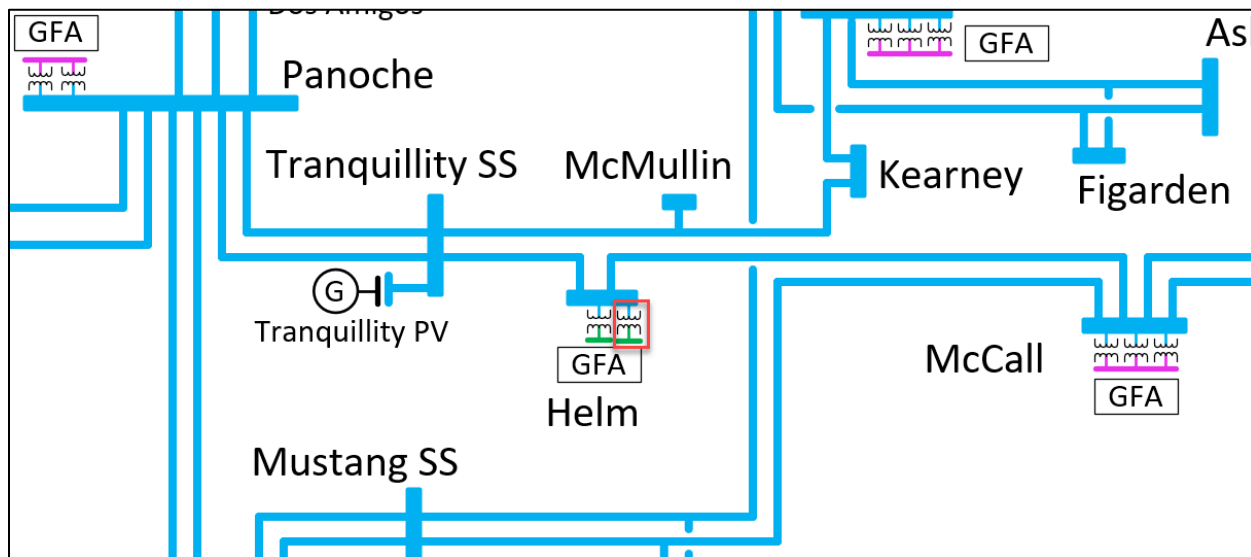

Table F.10-10 lists constraints identified only in the SSN scenario. These are provided for informative purposes and mitigation is not required for this scenario.

Table F.10-10: Deliverability constraints identified only in SSN scenario.

| Constraint                           | Contingency                    | Loading | Renewable Portfolio MW behind Constraint | Energy Storage Portfolio MW behind Constraint | Deliverable portfolio MW without mitigation | Potential Mitigation             |
|--------------------------------------|--------------------------------|---------|--|---|---|----------------------------------|
| Helm 230/70 kV Transformer #1        | CRESCENTSS-SCHLNDR #1 70KV [0] | 119.87% | 200                                      | 81  | 220   | SSN Only, No Mitigation Required |
| Panoche-Schindler #2 115 kV Line     | HELM 230/70KV TB 1             | 101.52% | 202                                      | 81  | 182   | SSN Only, No Mitigation Required |
| Schindler - Paiges SLR JCT 70kV Line | HELM 230/70KV TB 1             | 112.66% | 202                                      | 81  | 162   | SSN Only, No Mitigation Required |
| Schindler 115/70 kV Transformer #1   | HELM 230/70KV TB 1             | 131.39% | 200                                      | 91  | 166   | SSN Only, No Mitigation Required |
| Schindler-Coalinga #2 70 kV Line     | HELM 230/70KV TB 1             | 110.64% | 202                                      | 81  | 168   | SSN Only, No Mitigation Required |

| Constraint                         | Contingency                   | Loading | Renewable Portfolio MW behind Constraint | Energy Storage Portfolio MW behind Constraint | Deliverable portfolio MW without mitigation | Potential Mitigation             |
|------------------------------------|-------------------------------|---------|--|---|---|----------------------------------|
| Schindler-Huron-Gates 70 kV Line   | HELM 230/70KV TB 1            | 113.61% | 202                                      | 81  | 190   | SSN Only, No Mitigation Required |
| Warnerville - Wilson 230 kV Line   | COTTLE-MELONES 230KV [4530]   | 151.31% | 789                                      | 102   | 300   | SSN Only, No Mitigation Required |
| Wilson- Borden -Storey 230 kV Line | WILSON-BORDEN #1 230KV [5890] | 108.79% | 596                                      | 82  | 300   | SSN Only, No Mitigation Required |

**F.10.2 2034 Off-peak results**

The off-peak deliverability constraints identified in the base portfolio assessment of the Greater Fresno interconnection areas, along with the recommended mitigation plans, are identified in Table F.10-11.

Table F.10-11:PG&E Greater Fresno Interconnection Area Off-Peak Deliverability Constraints

| Constraint                                       | Contingency  | Loading | Renewable Portfolio MW behind Constraint | Energy Storage Portfolio MW behind Constraint | Renewable curtailment without mitigation | Potential Mitigation                                |
|--|--|---------|--|---|--|---|
| BARTON-AIRWAYS-SANGER 115kV Line                 | P7-1:A14:26:_HENTAP1-MUSTANGSS #1 230KV [0] & TRANQLTYSS-MCMULLN1 #1 230KV [0] | 106.82  | 23                                       | 0   | 0  | Reconductor if economic                             |
| Chowchilla-Kerckhoff 115kV Line                  | P7-1:A13:1:_WILSON-BORDEN 230KV #1 & #2 [9001]                                 | 149.78  | 2  | 0   | 0  | Reconductor if economic                             |
| Crescent Switching Station - Schindler 70kV Line | P12:A13:22:_TRANQUILLITY SW STA-HELM 230KV [5370]                              | 167.58  | 371                                      | 101   | 68                                       | 68 MW Portfolio Battery dispatched in charging mode |
| Fink Switching Station - Westley 230kV Line      | P1-2:A13:4:_QUINTO SW STA-WESTLEY 230KV [5070]                                 | 123.55  | 985                                      | 201   | 201                                      | Reconductor if economic                             |
| Fivepoint SSS - Calflax #1 70kV Line             | P1-3:A14:28:_HELM 230/70KV TB 1  | 144.6   | 350                                      | 81  | 49                                       | 49 MW Portfolio Battery dispatched in charging mode |
| Gates - Huron - Calflax 70 kV Line               | P1-3:A14:28:_HELM 230/70KV TB 1  | 154.31  | 350                                      | 81  | 58                                       | 58 MW Portfolio Battery dispatched in charging mode |
| Gates-Panoche #1 230kV Line                      | P1-2:A0:23:_GATES-MANNING 500KV [0]  | 149.18  | 858                                      | 116   | 116                                      | Reconductor if economic                             |
| Gates-Panoche #2 230kV Line                      | P1-2:A0:23:_GATES-MANNING 500KV [0]  | 158.49  | 858                                      | 116   | 116                                      | Reconductor if economic                             |
| GWF - Kingsburg 115kV Line                       | P7-1:A14:17:_HELM-MCCALL 230KV [4860] &  | 126.15  | 14                                       | 33  | 33                                       | Reconductor if economic                             |

|  |  |        |      |     |     |   |
|--|--|--------|------|-----|-----|---|
|  | HENTAP2-MUSTANGSS #1 230KV [0]   |        |      |     |     |   |
| Helm 230/70KV TB 1   | P7-1:A14:10:_PANOCHE-SCHINDLER #1 115KV [3250] & EXCELSIORSS-PANOCHE2 115KV [3231] | 152.25 | 350  | 91  | 91  | Reconductor if economic                             |
| Le Grand - Dairyland 115kV Line                              | P7-1:A13:13:_BORDEN-GREGG 230KV #1 & #2 [4400]                                     | 111.57 | 5    | 0   | 0   | Reconductor if economic                             |
| Los Banos - Manning #1 500kV Line                            | P1-2:A0:16:_LOSBANOS-MANNING 500KV [0] (2)   | 158.53 | 492  | 0   | 0   | Reconductor if economic                             |
| Los Banos - Manning #2 500kV Line                            | P1-2:A0:15:_LOSBANOS-MANNING 500KV [0]   | 158.53 | 492  | 0   | 0   | Reconductor if economic                             |
| Los Banos - Panoche #2 230kV Line                            | P1-3:A0:15:_LOSBANOS 500/230KV TB 1  | 125.32 | 108  | 0   | 0   | Reconductor if economic                             |
| Los Banos-Quinto Switching Station 230kV Line                | P1-2:A0:11:_TESLA-LOS BANOS #1 500KV [6100]  | 173.06 | 836  | 171 | 171 | Reconductor if economic                             |
| Manning - Gates 500kV Line                                   | Base Case  | 135.84 | 3783 | 307 | 307 | Reconductor if economic                             |
| Mc Call - Sanger #3 115kV Line                               | P7-1:A14:26:_HENTAP1-MUSTANGSS #1 230KV [0] & TRANQLTYSS-MCMULLN1 #1 230KV [0]     | 115.27 | 21   | 0   | 0   | Reconductor if economic                             |
| Melones - Wilson 230kV Line                                  | P12:A13:3:_WARNERVILLE-WILSON 230KV [5870]   | 124.14 | 519  | 0   | 0   | Reconductor if economic                             |
| Moss Landing-Las Aguilas Switching Station 230kV Line        | P1-2:A0:13:_MOSS LANDING-LOS BANOS 500KV [6040]                                    | 144.61 | 100  | 0   | 0   | Reconductor if economic                             |
| Panoche - Excelsior Switching Station #2 115kV Line          | P1-3:A14:28:_HELM 230/70KV TB 1  | 124.02 | 350  | 81  | 33  | 33 MW Portfolio Battery dispatched in charging mode |
| Panoche-Schindler #1 115 kV Line                             | P1-3:A14:28:_HELM 230/70KV TB 1  | 123.35 | 431  | 81  | 56  | 56 MW Portfolio Battery dispatched in charging mode |
| Quinto Switching Station - Fink Switching Station 230kV Line | P1-2:A13:4:_QUINTO SW STA-WESTLEY 230KV [5070]                                     | 117.19 | 985  | 201 | 201 | Reconductor if economic                             |
| Quinto Switching Station-Westley 230kV Line                  | P1-2:A13:1:_FINKSWSTA-WESTLEY #1 230KV [0]   | 123.24 | 985  | 201 | 201 | Reconductor if economic                             |
| Schindler 115/70 kV Transformer #1                           | P1-3:A14:28:_HELM 230/70KV TB 1  | 214.23 | 348  | 90  | 90  | Reconductor if economic                             |
| Schindler-Coalinga #2 70 kV Line                             | P1-3:A14:28:_HELM 230/70KV TB 1  | 123.84 | 350  | 81  | 21  | 21 MW Portfolio Battery dispatched in charging mode |
| Warnerville - Wilson 230 kV Line                             | P1-2:A12:2:_COTTLE-MELONES 230KV [4530]  | 220.06 | 554  | 83  | 83  | Reconductor if economic                             |
| Wilson - Borden #1 230kV Line                                | P1-2:A13:27:_WILSON-BORDEN #2 230KV [9001]   | 178.29 | 332  | 83  | 83  | Reconductor if economic                             |
| Wilson - Borden #2 230kV Line                                | P1-2:A13:26:_WILSON-BORDEN #1 230KV [5890]   | 154.45 | 332  | 83  | 83  | Reconductor if economic                             |
| Wilson-Le Grand 115 kV Line                                  | P7-1:A13:1:_WILSON-BORDEN 230KV #1 & #2 [9001]                                     | 105.41 | 17   | 0   | 0   | Reconductor if economic                             |
| Wilson-Oro Loma 115 kV Line                                  | P7-1:A13:13:_BORDEN-GREGG 230KV #1 & #2 [4400]                                     | 186.31 | 0.8  | 0   | 0   | Reconductor if economic                             |



Critical constraints identified in off peak study have been evaluated as part of the economic study. For mitigation please refer to the economic study process.

**F.10.3 2039 On-peak results**

**McCall-Sanger #1 115 kV Line on-peak deliverability constraint**

The deliverability of renewable portfolio resources in the Fresno area is limited by thermal overloading of the McCall-Sanger #1 115 kV Line under N-2 conditions as shown Table F.10-12. This constraint was identified in baseline portfolio under HSN conditions. As shown in Table F.10-13, 0 MW of renewable and energy storage would be deliverable without any transmission upgrades. This is a local constraint and will be addressed in GIP.

Table F.10-12: McCall-Sanger #1 115 kV Line on-peak deliverability constraint

| Overloaded Facility          | Contingency  | Scenario | Loading |             |
|------------------------------|--|----------|---------|-------------|
|                              |  |          | HSN     | Sensitivity |
| McCall-Sanger #1 115 kV Line | MCCALL-REEDLEY 115KV [2320] & MCCALL-SANGER#3 115KV [2350] | HSN      | 104.58% | 107.65%     |

Table F.10-13: McCall-Sanger #1 115 kV Line on-peak deliverability constraint summary

| Affected transmission zones: PG&E Fresno Area  |  |  |             |
|--|--|--|-------------|
|  |  | Base                                       | Sensitivity |
| Generic Portfolio MW behind the constraint (installed FCDS capacity)                 |  | 21   | 10          |
| Generic Battery storage portfolio MW behind the constraint (installed FCDS capacity) |  | 0  | 32          |
| Deliverable Generic Portfolio MW w/o mitigation (Installed FCDS capacity)            |  | 0  | 0           |
| Total undeliverable baseline and portfolio MW (Installed FCDS capacity)              |  | 163  | 146         |
| Mitigation Options   | RAS  | N/A  | N/A         |
|  | Re-locate generic portfolio battery storage (MW) | N/A  | N/A         |
|  | Transmission upgrade including cost              | N/A  | N/A         |
| Recommended Mitigation   |  | Local constraint. Will be addressed in GIP |             |

**McCall-Sanger #2 115 kV Line on-peak deliverability constraint**

The deliverability of renewable portfolio resources in the Fresno area is limited by thermal overloading of the McCall-Sanger #2 115 kV Line under N-2 conditions as shown Table F.10-14. This constraint was identified in baseline portfolio under HSN conditions. As shown in Table F.10-15, 0 MW of renewable and energy storage would be deliverable without any transmission upgrades. This is a local constraint and will be addressed in GIP.

Table F.10-14: McCall-Sanger #2 115 kV Line on-peak deliverability constraint

| Overloaded Facility | Contingency | Scenario | Loading |
|---------------------|-------------|----------|---------|
|---------------------|-------------|----------|---------|

|                              |  |     | HSN    | Sensitivity |
|------------------------------|--|-----|--------|-------------|
| McCall-Sanger #2 115 kV Line | MCCALL-REEDLEY 115KV [2320] & MCCALL-SANGER#3 115KV [2350] | HSN | 118.1% | 121.56%     |

Table F.10-15: McCall-Sanger #2 115 kV Line on-peak deliverability constraint summary

| Affected transmission zones: PG&E Fresno Area  |  |  |             |
|--|--|--|-------------|
|  |  | Base                                       | Sensitivity |
| Generic Portfolio MW behind the constraint (installed FCDS capacity)                 |  | 21   | 10          |
| Generic Battery storage portfolio MW behind the constraint (installed FCDS capacity) |  | 0  | 32          |
| Deliverable Generic Portfolio MW w/o mitigation (Installed FCDS capacity)            |  | 0  | 0           |
| Total undeliverable baseline and portfolio MW (Installed FCDS capacity)              |  | 163  | 146         |
| Mitigation Options   | RAS  | N/A  | N/A         |
|  | Re-locate generic portfolio battery storage (MW) | N/A  | N/A         |
|  | Transmission upgrade including cost              | N/A  | N/A         |
| Recommended Mitigation   |  | Local constraint. Will be addressed in GIP |             |

**Corcoran-Smyrna (Alpaugh-Smyrna) 115 kV Line on-peak deliverability constraint**

The deliverability of renewable portfolio resources in the Fresno area is limited by thermal overloading of the Corcoran-Smyrna (Alpaugh-Smyrna) 115 kV Line under base case condition as shown Table F.10-16. This constraint was identified in sensitivity portfolio under HSN conditions. As shown in Table F.10-17, 34 MW of renewable and energy storage would be deliverable without any transmission upgrades. No mitigation proposed since it is only observed in the sensitivity scenario.

Table F.10-16: Corcoran-Smyrna (Alpaugh-Smyrna) 115 kV Line on-peak deliverability constraint

| Overloaded Facility                          | Contingency | Scenario | Loading |             |
|--|-------------|----------|---------|-------------|
|  |             |          | HSN     | Sensitivity |
| Corcoran-Smyrna (Alpaugh-Smyrna) 115 kV Line | Base Case   | HSN      | <100%   | 112.27%     |

Table F.10-17: Corcoran-Smyrna (Alpaugh-Smyrna) 115 kV Line on-peak deliverability constraint summary

|   |  |
|---|--|
| Affected transmission zones: PG&E Fresno Area |  |
|---|--|

|  |     | Base                                     | Sensitivity |
|--|-----|--|-------------|
| Generic Portfolio MW behind the constraint (installed FCDS capacity)                 |     | N/A                                      | 24          |
| Generic Battery storage portfolio MW behind the constraint (installed FCDS capacity) |     | N/A                                      | 10          |
| Deliverable Generic Portfolio MW w/o mitigation (Installed FCDS capacity)            |     | N/A                                      | 34          |
| Total undeliverable baseline and portfolio MW (Installed FCDS capacity)              |     | N/A                                      | 0           |
| Mitigation Options   | N/A | N/A                                      | N/A         |
|  | N/A | N/A                                      | N/A         |
|  | N/A | N/A                                      | N/A         |
| Recommended Mitigation   |     | Sensitivity only, no mitigation required |             |

### F.10.4 Conclusion and recommendation

The PGE Greater Fresno area base and sensitivity portfolios deliverability assessment identified on-peak and off-peak deliverability constraints. The GWF-Kingsburg 115 kV line constraint is identified in 2034 on-peak scenario and the CAISO recommends reconductoring the line as mitigation. The CAISO also recommends installing a second 230/70kV transformer bank at Helm substation to mitigate the Helm-Crescent 70kV line constraint.

### F.11 PG&E East Kern Interconnection Area

The total capacity of resources, by resource type, selected with Full Capacity Deliverability Status (FCDS) as well as those selected as Energy Only (EO) in the PG&E East Kern interconnection area are listed in Table F.11-1. The portfolios in the interconnect area are comprised of solar, wind (in-state and offshore), battery storage, biomass/biogas and distributed solar resources. All portfolio resources are modeled in policy-driven assessments except in the on-peak deliverability assessment in which only FCDS resources are modeled.

Table F.11-1: PG&E East Kern Interconnection Area – Base and Sensitivity Portfolios by Resource Types (FCDS, EO and Total)

| Resource Type                       | 2034 Base Portfolio |         |            | 2039 Base Portfolio |         |            | 2039 Sensitivity Portfolio |         |            |
|-------------------------------------|---------------------|---------|------------|---------------------|---------|------------|----------------------------|---------|------------|
|                                     | FCDS (MW)           | EO (MW) | Total (MW) | FCDS (MW)           | EO (MW) | Total (MW) | FCDS (MW)                  | EO (MW) | Total (MW) |
| Solar                               | 680                 | 1,301   | 1,981      | 1,036               | 2,061   | 3,096      | 2,029                      | 2,762   | 4,791      |
| Wind – In State                     | 300                 | 10      | 310        | 300                 | 10      | 310        | 190                        | 10      | 200        |
| Wind – Out-of-State                 | 0                   | 0       | 0          | 0                   | 0       | 0          | 0                          | 0       | 0          |
| Wind - Offshore                     | 2,924               | 0       | 2,924      | 2,924               | 0       | 2,924      | 0                          | 0       | 0          |
| Li Battery – 4 hr                   | 777                 | 0       | 777        | 777                 | 0       | 777        | 186                        | 0       | 186        |
| Li Battery – 8 hr                   | 142                 | 0       | 142        | 682                 | 0       | 682        | 1,217                      | 0       | 1,217      |
| Long Duration Energy Storage (LDES) | 0                   | 0       | 0          | 0                   | 0       | 0          | 400                        | 0       | 400        |
| Geothermal                          | 0                   | 0       | 0          | 0                   | 0       | 0          | 0                          | 0       | 0          |
| Biomass/Biogas                      | 18                  | 0       | 18         | 18                  | 0       | 18         | 0                          | 0       | 0          |

|                   |              |              |              |              |              |              |              |              |              |
|-------------------|--------------|--------------|--------------|--------------|--------------|--------------|--------------|--------------|--------------|
| Distributed Solar | 73           | 0            | 73           | 73           | 0            | 73           | 79           | 0            | 79           |
| <b>Total</b>      | <b>4,913</b> | <b>1,311</b> | <b>6,224</b> | <b>5,809</b> | <b>2,071</b> | <b>7,879</b> | <b>4,101</b> | <b>2,772</b> | <b>6,873</b> |

The resources as identified in the CPUC busbar mapping for the PG&E East Kern interconnection area are illustrated on the single-line diagrams in Figure F.11-1 and Figure F.11-2. No adjustments were made to the portfolios in this area to account for allocated TPD and additional in-development resources identified.

Figure F.11-1: PG&E East Kern Interconnection Area – Mapped 2034 Base Portfolio

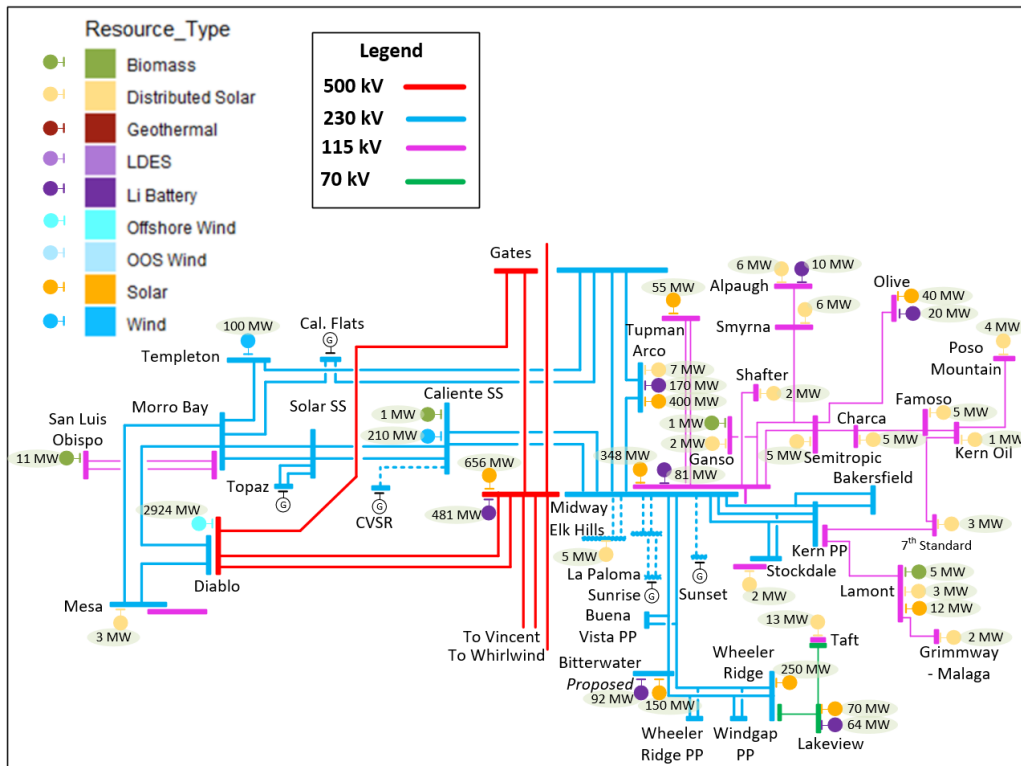
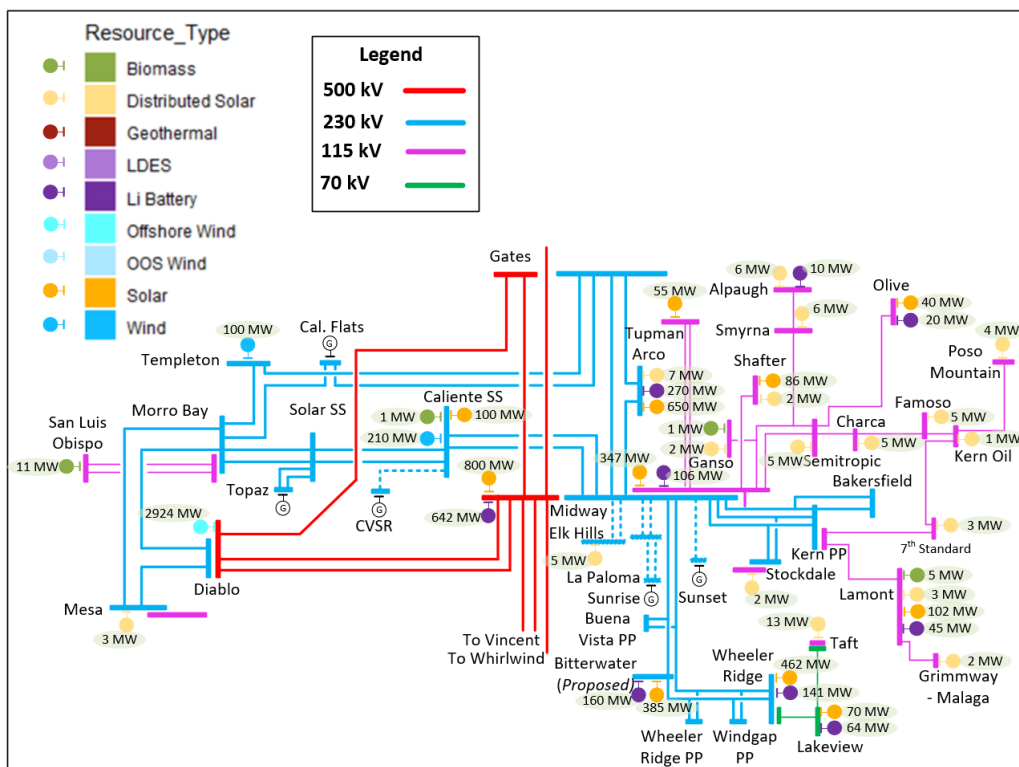

Figure F.11-2: PG&E East Kern Interconnection Area – Mapped 2039 Base Portfolio



**F.11.1 2034 On-peak results**

There were no constraints observed in 2034 HSN on-peak scenario. Table F.11-2 lists constraints identified only in the SSN scenario. These are provided for informative purposes and mitigation is not required for this scenario.

Table F.11-2: Deliverability constraints identified only in SSN scenario

| Constraint                             | Contingency  | Loading | Renewable Portfolio MW behind Constraint | Energy Storage Portfolio MW behind Constraint | Deliverable Portfolio MW without mitigation | Potential Mitigation             |
|--|--|---------|--|---|---|----------------------------------|
| Copus-Old River 70 kV Line             | MIDWAY-KERN #4 & KERN-BAKERSFIELD & MIDWAY-KERN #3 LINES | 103.24% | 13                                       | 0   | 0   | SSN Only, No Mitigation Required |
| Oceano-Callender Sw. Sta 115 kV Line   | MORROBAY 230/115KV TB 6                                  | 108.98% | 189                                      | 110   | 29  | SSN Only, No Mitigation Required |
| South Kern Jct - San Emidio 70 kV Line | MIDWAY-KERN #4 & KERN-BAKERSFIELD & MIDWAY-KERN #3 LINES | 103.45% | 13                                       | 0   | 0   | SSN Only, No Mitigation Required |

**F.11.2 2034 Off-peak results**

The off-peak deliverability constraints identified in the base portfolio assessment of the Kern interconnection area, along with the recommended mitigation plans, are identified in Table F.11-3.

Table F.11-3: PG&E Greater Kern Interconnection Area Off-Peak Deliverability Constraints

| Constraint                                    | Contingency  | Loading | Renewable Portfolio MW behind Constraint | Energy Storage Portfolio MW behind Constraint | Renewable curtailment without mitigation | Potential Mitigation                                 |
|---|--|---------|--|---|--|--|
| Callendar Switching Station - Mesa 115kV Line | P7-1:A20:16:_Morro Bay-Mesa and Morro Bay-Diablo 230 kV Lines              | 271.12  | 503.2                                    | 115.92  | 105.92                                   | Reconductor if economic                              |
| San Miguel - UnionPGAE 70kV Line              | P7-1:A14:14:_TEMPLET ON-GATES 230KV [5934] & GATES-CALFLATSSS #1 230KV [0] | 114.38  | 614.2                                    | 115.92  | 104                                      | 104 MW Portfolio Battery dispatched in charging mode |

Critical constraints identified in off peak study have been evaluated as part of the economic study. For mitigation please refer to the economic study process.

**F.11.3 2039 On-peak results**

There were no constraints observed in the 2039 on-peak scenario.

**F.11.4 Conclusion and recommendation**

The PGE Kern area base portfolio deliverability assessment identified on-peak (SSN scenario only) and off-peak deliverability constraints. These constraints are provided for informative purposes and do not require mitigation.

**F.12 East of Pisgah area**

The total capacity of resources, by resource type, selected with Full Capacity Deliverability Status (FCDS) as well as those selected as Energy Only (EO) in the East of Pisgah interconnection area are listed in Table F.12-1. The portfolios in the interconnection area are comprised of solar, wind (in-state and out-of-state), battery storage and geothermal resources. All portfolio resources are modeled in policy-driven assessments except in the on-peak deliverability assessment in which only FCDS resources are modeled.

Table F.12-1: East of Pisgah Interconnection Area – Base and Sensitivity Portfolios by Resource Types (FCDS, EO and Total)

| Resource Type                       | 2034 Base Portfolio |              |               | 2039 Base Portfolio |              |               | 2039 Sensitivity Portfolio |              |               |
|-------------------------------------|---------------------|--------------|---------------|---------------------|--------------|---------------|----------------------------|--------------|---------------|
|                                     | FCDS (MW)           | EO (MW)      | Total (MW)    | FCDS (MW)           | EO (MW)      | Total (MW)    | FCDS (MW)                  | EO (MW)      | Total (MW)    |
| Solar                               | 1,075               | 1,565        | 2,640         | 1,200               | 3,030        | 4,230         | 2,425                      | 3,855        | 6,280         |
| Wind – In State                     | 620                 | 0            | 620           | 620                 | 0            | 620           | 620                        | 0            | 620           |
| Wind – Out-of-State                 | 3,965               | 0            | 3,965         | 4,060               | 0            | 4,060         | 4,060                      | 0            | 4,060         |
| Wind - Offshore                     | 0                   | 0            | 0             | 0                   | 0            | 0             | 0                          | 0            | 0             |
| Li Battery – 4 hr                   | 3,954               | 0            | 3,954         | 3,735               | 0            | 3,735         | 2,839                      | 0            | 2,839         |
| Li Battery – 8 hr                   | 180                 | 0            | 180           | 696                 | 0            | 696           | 1,769                      | 0            | 1,769         |
| Long Duration Energy Storage (LDES) | 0                   | 0            | 0             | 0                   | 0            | 0             | 0                          | 0            | 0             |
| Geothermal                          | 875                 | 0            | 875           | 875                 | 0            | 875           | 1,315                      | 0            | 1,315         |
| Biomass/Biogas                      | 0                   | 0            | 0             | 0                   | 0            | 0             | 0                          | 0            | 0             |
| Distributed Solar                   | 0                   | 0            | 0             | 0                   | 0            | 0             | 0                          | 0            | 0             |
| <b>Total</b>                        | <b>10,669</b>       | <b>1,565</b> | <b>12,234</b> | <b>11,186</b>       | <b>3,030</b> | <b>14,216</b> | <b>13,028</b>              | <b>3,855</b> | <b>16,883</b> |

The resources as identified in the CPUC busbar mapping for the East of Pisgah interconnection area are illustrated on the single-line diagram in Figure F.12-1 and Figure F.12-2.

Figure F.12-1: East of Pisgah Interconnection Area – Mapped<sup>16</sup> 2034 Base Portfolio

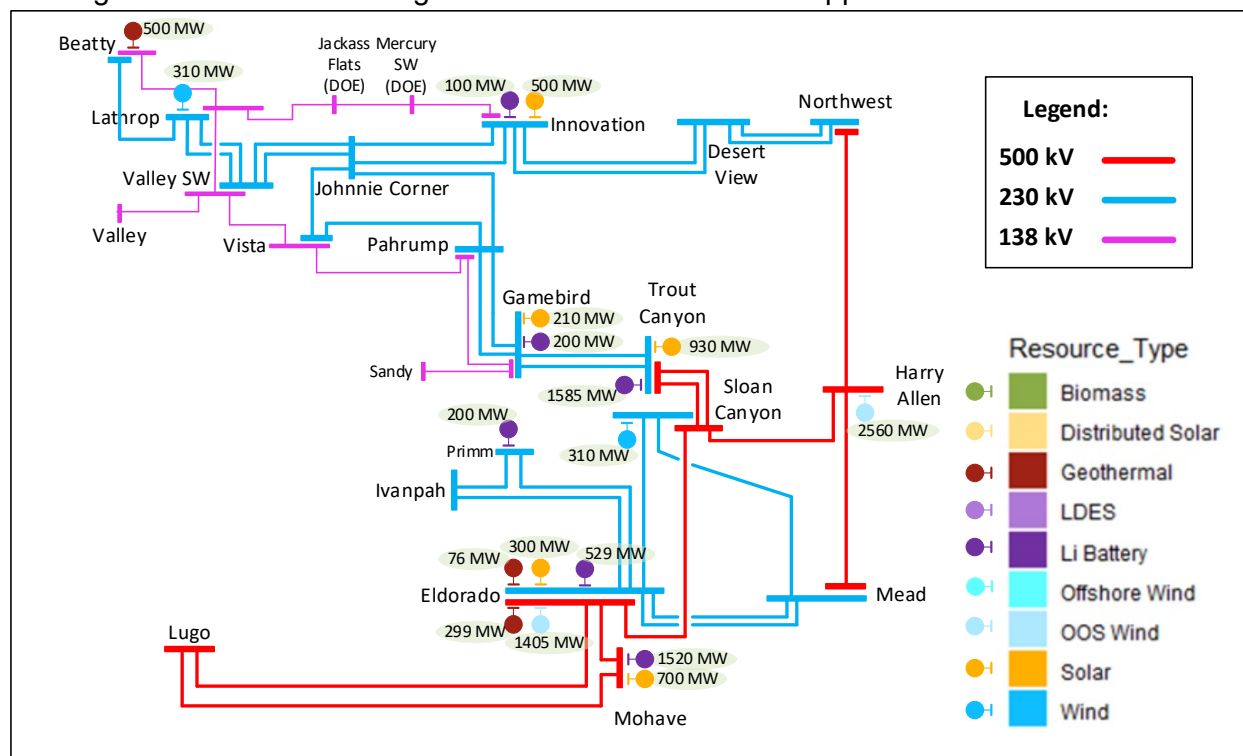

<sup>16</sup> Mapped base portfolio includes the adjustments to the base portfolio made by CPUC staff in the East of Pisgah Interconnection Area to account for allocated TPD and additional in-development resources identified.



Figure 12-2: East of Pisgah Interconnection Area – Mapped<sup>17</sup> 2039 Base Portfolio

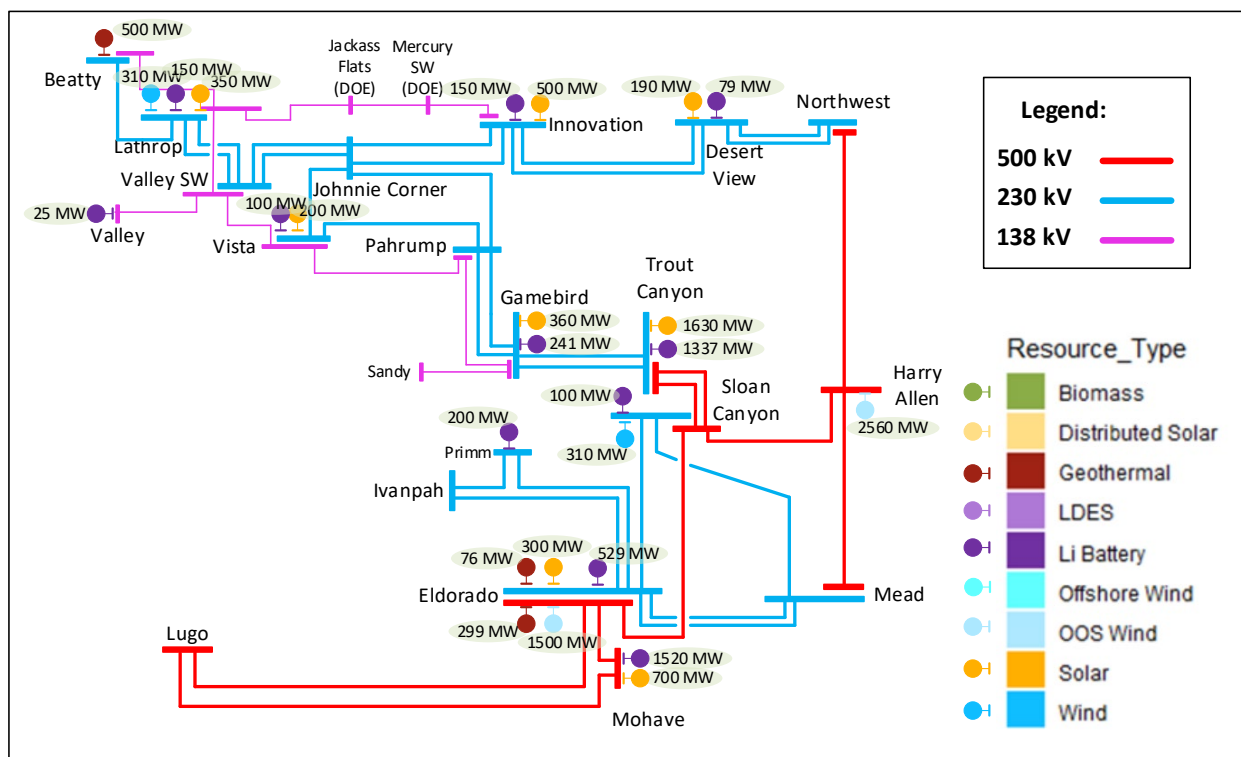

**F.12.1 2034 On-peak results**

**GLW-VEA Area Constraint**

The deliverability of full capacity portfolio resources in the VEA and GLW area is limited by thermal overloading of multiple 138 kV lines following Category P7 contingencies as shown in Table F.12-2. This constraint was identified in base portfolio under HSN and SSN conditions. As shown in Table F.12-3, 3,460 MW of renewable and energy storage resources are behind the constraint and 1,892 MW would be undeliverable.

Table F.12-2: VEA-GLW 2034 on-peak deliverability constraints

| Overloaded Facility            | Contingency                                      | Loading (%) |     |
|--------------------------------|--|-------------|-----|
|                                |  | HSN         | SSN |
| Gamebird 230/138kV transformer | Trout Canyon – Sloan Canyon 500kV Nos. 1&2 lines | 152         | 151 |
| Gamebird – Sandy 138kV line    |  | 127         | 138 |
| Sandy – Amargosa 138kV line    |  | 146         | 159 |
| Amargosa 230/138kV transformer |  | 111         | 121 |

<sup>17</sup> Mapped base portfolio includes the adjustments to the base portfolio made by CPUC staff in the East of Pisgah Interconnection Area to account for allocated TPD and additional in-development resources identified.

|  |  |     |     |
|--|--|-----|-----|
| Innovation PST – IS Tap – Northwest 138kV tie line |  | 140 | 147 |
| Innovation PST – Is Tap 138kV line                 | Innovation – Desert View 230kV Nos.1&2 lines | 101 | 109 |
|  | Desert View – Northwest 230kV Nos.1&2 lines  | 101 | 109 |

Table F.12-3: VEA-GLW 2034 on-peak constraint summary

|  |                                     |  |
|--|-------------------------------------|--|
| Affected transmission zones  |                                     | GLW and VEA area   |
| Portfolio resources behind the constraint (Installed FCDS capacity)            |                                     | 3,460 MW   |
| Portfolio battery storage behind the constraint (Installed FCDS capacity)      |                                     | 1,700 MW   |
| Deliverable portfolio resources w/o mitigation (Installed FCDS capacity)       |                                     | 1,568 MW   |
| Total undeliverable baseline and portfolio resources (Installed FCDS capacity) |                                     | 1,892 MW   |
| Mitigation Options   | RAS                                 | RAS identified in GIP and reduce generic battery storage in the area |
|  | Reduce generic battery storage (MW) |  |
|  | Transmission upgrade including cost | Trout Canyon – Lugo 500 kV line (\$2 B)                              |
| Recommended Mitigation   |                                     | TBD  |

The constraint can be mitigated by the future Trout Canyon RAS as proposed in the GIDAP process along with reducing battery storage in the area. The new Trout Canyon – Lugo 500 kV line would also mitigate all the overloads identified. But the need for Trout Canyon – Lugo 500 kV line will also be coordinated with the transmission upgrade to accommodate the out-of-state wind portfolio. As will be discussed later, the recommended mitigation at this time remains TBD.

**Eldorado - McCullough 500 kV Constraint**

The deliverability of full capacity portfolio resources of in the East of Pisgah area and the deliverability of out-of-state wind resources is limited by thermal overloading of Eldorado - McCullough 500 kV line following Category P1 contingencies as shown in Table F.12-4. This constraint was identified in base portfolio under both HSN and SSN conditions with HSN more limiting. As shown in Table F.12-5, 10,480 MW of renewable and energy storage resources are behind the constraint and 2,759 MW would be undeliverable. MIC expansion request on the MEAD\_ITC intertie is behind this constraint and the 114 MW MIC expansion request is undeliverable. A few alternatives were evaluated to mitigate the constraint. The final mitigation plan will be coordinated with Eldorado 500 kV SCD mitigation and the transmission upgrade to accommodate the out-of-state wind portfolio.

Table F.12-4: Eldorado - McCullough 500 kV 2034 on-peak deliverability constraints

| Overloaded Facility               | Contingency                    | Loading (%) |      |
|-----------------------------------|--------------------------------|-------------|------|
|                                   |                                | HSN         | SSN  |
| Eldorado – McCullough 500 kV line | Eldorado – Lugo 500 kV line    | 143         | 122  |
|                                   | Lugo – Mohave 500 kV line      | 134         | 118  |
|                                   | Harry Allen – Mead 500 kV line | 109         | 103  |
|                                   | Eldorado – Mohave 500 kV line  | 104         | <100 |

Table F.12-5: Eldorado - McCullough 500 kV 2034 on-peak constraint summary

|  |                                     |   |
|--|-------------------------------------|---|
| Affected transmission zones  |                                     | East of Pisgah, Out-of-state Wind   |
| Portfolio resources behind the constraint (Installed FCDS capacity)            |                                     | 10,480 MW   |
| Portfolio battery storage behind the constraint (Installed FCDS capacity)      |                                     | 4,070 MW  |
| Deliverable portfolio resources w/o mitigation (Installed FCDS capacity)       |                                     | 7,721 MW  |
| Total undeliverable baseline and portfolio resources (Installed FCDS capacity) |                                     | 2,759 MW  |
| Mitigation Options   | RAS                                 | Not applicable  |
|  | Reduce generic battery storage (MW) | Not sufficient  |
|  | Transmission upgrade including cost | 1. 10 Ohms series reactor on Eldorado – McCullough line<br>2. Trout Canyon – Lugo 500kV line (\$2B)<br>3. Marketplace-Adelanto AC-DC Conversion<br>4. Western Bounty HVDC |
| Recommended Mitigation   |                                     | TBD   |

**Lugo – Victorville 500 kV Constraint**

The deliverability of full capacity portfolio resources of in the East of Pisgah, SCE Eastern, SCE Northern and SDG&E areas and the deliverability of out-of-state wind resources is limited by thermal overloading of Lugo – Victorville 500 kV lines following Category P1 contingency as shown in Table F.12-6. This constraint was identified in base portfolio under HSN condition. As shown in Table F.12-7, 14,178 MW of renewable and energy storage resources are behind the constraint and 184 MW would be undeliverable. MIC expansion request on the MEAD\_ITC and BLYTHE\_ITC interties are behind this constraint and the 282 MW MIC expansion request is deliverable taken into account the existing RAS operation. The constraint can be mitigated by utilizing the existing Lugo – Victorville RAS.

Table F.12-6: Lugo - Victorville 500 kV 2034 on-peak deliverability constraints

| Overloaded Facility            | Contingency                 | Loading (%) |      |
|--------------------------------|-----------------------------|-------------|------|
|                                |                             | HSN         | SSN  |
| Lugo – Victorville 500 kV line | Eldorado – Lugo 500 kV line | 102         | <100 |

Table F.12-7: Lugo – Victorville 500 kV 2034 on-peak constraint summary

|  |                                     |   |
|--|-------------------------------------|---|
| Affected transmission zones  |                                     | East of Pisgah, SCE Eastern, SCE Northern, SDG&E, Out-of-state Wind |
| Portfolio resources behind the constraint (Installed FCDS capacity)            |                                     | 14,178 MW   |
| Portfolio battery storage behind the constraint (Installed FCDS capacity)      |                                     | 5,022 MW  |
| Deliverable portfolio resources w/o mitigation (Installed FCDS capacity)       |                                     | 13,994 MW   |
| Total undeliverable baseline and portfolio resources (Installed FCDS capacity) |                                     | 184 MW  |
| Mitigation Options   | RAS                                 | Existing Lugo – Victorville RAS                                     |
|  | Reduce generic battery storage (MW) | Not needed  |
|  | Transmission upgrade including cost | Not needed  |
| Recommended Mitigation   |                                     | Existing Lugo – Victorville RAS                                     |

|  |                     |
|--|---------------------|
| Affected interties                         | MEAD_ITC,BLYTHE_ITC |
| MIC expansion request MW behind constraint | 282                 |
| Deliverable MIC expansion request MW       | 282                 |

### F.12.2 2034 Off-peak results

The off-peak deliverability assessment did not identify any constraints in EOP area under 2034 base portfolio.

### F.12.3 2039 On-peak results

#### GLW-VEA Area Constraint

The deliverability of full capacity portfolio resources in the VEA and GLW area is limited by thermal overloading of multiple 138 kV lines following Category P7 contingencies as shown in Table F.12-8. This constraint was identified for both 2039 base and sensitivity portfolios. Table F.12-9 summarizes the renewable and energy storage resources behind the constraint and the undeliverable resources in both base and sensitivity portfolios. The future Trout Canyon RAS

identified in the GIDAP process is sufficient to mitigate the constraint for 2039 base portfolio. For 2039 sensitivity portfolio, additional transmission upgrade will be needed.

Table F.12-8: GLW-VEA 2039 on-peak deliverability constraints

| Overloaded Facility                          | Contingency                                      | Loading (%) |             |
|--|--|-------------|-------------|
|  |  | Base        | Sensitivity |
| Gamebird 230/138 kV Transformer              | Trout Canyon – Sloan Canyon 500kV Nos. 1&2 lines | 148         | 161         |
| Gamebird – Sandy 138 kV Line                 |  | 128         | 143         |
| Sandy – Amargosa 138 kV Line                 |  | 147         | 165         |
| Amargosa 230/138 kV Transformer              |  | 110         | 126         |
| VEA PST – IS Tap – Northwest 138 kV Tie Line |  | 153         | 152         |
| VEA PST – IS Tap – Northwest 138 kV Tie Line | Northwest – Desert View 230kV Nos. 1&2 lines     | 119         | 135         |
|  | Innovation – Desert View 230kV Nos. 1&2 lines    | 109         | 127         |

Table F.12-9: GLW-VEA 2039 on-peak constraint summary

| Affected transmission zones  |                                     | GLW and VEA area        |  |
|--|-------------------------------------|-------------------------|--|
|  |                                     | Base                    | Sensitivity                            |
| Portfolio resources behind the constraint (Installed FCDS capacity)            |                                     | 3,476 MW                | 4,239 MW                               |
| Portfolio battery storage behind the constraint (Installed FCDS capacity)      |                                     | 1,891 MW                | 2,033 MW                               |
| Deliverable portfolio resources w/o mitigation (Installed FCDS capacity)       |                                     | 2,259 MW                | 2,016 MW                               |
| Total undeliverable baseline and portfolio resources (Installed FCDS capacity) |                                     | 1,217 MW                | 2,223 MW                               |
| Mitigation Options   | RAS                                 | RAS identified in GIP   | Not applicable                         |
|  | Reduce generic battery storage (MW) | Not sufficient          | Not sufficient                         |
|  | Transmission upgrade including cost | Not needed              | Trout Canyon – Lugo 500kV line (\$2 B) |
| Recommended Mitigation   |                                     | RAS identified in GIDAP | TBD                                    |

**Eldorado - McCullough 500 kV Constraint**

The deliverability of full capacity portfolio resources of in the East of Pisgah area and the deliverability of out-of-state wind resources is limited by thermal overloading of Eldorado -

McCullough 500 kV line in base case and following Category P1 contingencies as shown in Table F.12-10. This constraint was identified for both 2039 base and sensitivity portfolios. Table F.12-11 summarizes the renewable and battery resources behind the constraint and the undeliverable resources for both 2039 base and sensitivity portfolios. MIC expansion request on the MEAD\_ITC intertie is behind this constraint and the 114 MW MIC expansion request is undeliverable. A few alternatives were evaluated to mitigate the constraint. The final mitigation plan will be coordinated with Eldorado 500 kV SCD mitigation and the transmission upgrades to accommodate the out-of-state wind portfolio.

Table F.12-10: Eldorado - McCullough 500 kV 2039 on-peak deliverability constraints

| Overloaded Facility               | Contingency                    | Loading (%) |             |
|-----------------------------------|--------------------------------|-------------|-------------|
|                                   |                                | Base        | Sensitivity |
| Eldorado – McCullough 500 kV line | Base Case                      | <100        | 101         |
|                                   | Eldorado – Lugo 500 kV line    | 157         | 161         |
|                                   | Lugo – Mohave 500 kV line      | 142         | 146         |
|                                   | Harry Allen – Mead 500 kV line | 108         | 113         |

Table F.12-11: Eldorado – McCullough 500 kV 2039 on-peak constraint summary

| Affected transmission zones  |                                     | East of Pisgah, Out-of-state Wind  |             |
|--|-------------------------------------|--|-------------|
|  |                                     | Base   | Sensitivity |
| Portfolio resources behind the constraint (Installed FCDS capacity)            |                                     | 11,119 MW  | 13,133 MW   |
| Portfolio battery storage behind the constraint (Installed FCDS capacity)      |                                     | 4,413 MW   | 4,660 MW    |
| Deliverable portfolio resources w/o mitigation (Installed FCDS capacity)       |                                     | 7,072 MW   | 8,243 MW    |
| Total undeliverable baseline and portfolio resources (Installed FCDS capacity) |                                     | 4,047 MW   | 4,890 MW    |
| Mitigation Options   | RAS                                 | Not applicable   |             |
|  | Reduce generic battery storage (MW) | Not applicable   |             |
|  | Transmission upgrade including cost | 1. 10 Ohms series reactor on Eldorado – McCullough line<br>2. Trout Canyon – Lugo 500kV line (\$2 B) with 200-400MW battery storage relocation<br>3. Marketplace-Adelanto AC-DC Conversion<br>4. Western Bounty HVDC |             |
| Recommended Mitigation   |                                     | TBD  |             |

|  |          |             |
|--|----------|-------------|
| Affected interties                         | MEAD_ITC |             |
|  | Base     | Sensitivity |
| MIC expansion request MW behind constraint | 114      | 114         |
| Deliverable MIC expansion request MW       | 0        | 0           |

**Lugo – Victorville 500 kV Constraint**

The deliverability of full capacity portfolio resources of in the East of Pisgah, SCE Easter, SCE North and SDG&E areas and the deliverability of out-of-state wind resources are limited by thermal overloading of Lugo – Victorville 500 kV line as shown in Table F.12-12. This constraint was identified for both 2039 base and sensitivity portfolios. Table F.12-13 summarizes the renewable and battery resources behind the constraint and the undeliverable resources for both 2039 base and sensitivity portfolios. MIC expansion requests on the MEAD\_ITC and BLYTHE\_ITC interties are behind this constraint and the 282 MW MIC expansion requests are undeliverable. A few alternatives were evaluated to mitigate the constraint. The final mitigation plan will be coordinated with transmission upgrades to accommodate the out-of-state wind portfolio.

Table F.12-12: Lugo – Victorville 500 kV 2039 on-peak deliverability constraints

| Overloaded Facility            | Contingency                    | Loading (%) |             |
|--------------------------------|--------------------------------|-------------|-------------|
|                                |                                | Base        | Sensitivity |
| Lugo – Victorville 500 kV line | Base Case                      | 112         | 114         |
|                                | Eldorado – Lugo 500 kV line    | 127         | 130         |
|                                | Lugo – Mohave 500 kV line      | 142         | 146         |
|                                | Harry Allen – Mead 500 kV line | 108         | 113         |
| Eldorado – Lugo 500 kV line    | Lugo – Victorville 500 kV line | 111         | 113         |

Table F.12-13: Lugo – Victorville 500 kV 2039 on-peak constraint summary

| Affected transmission zones  | East of Pisgah, SCE Eastern, SCE Northern, SDG&E |             |
|--|--|-------------|
|  | Base   | Sensitivity |
| Portfolio resources behind the constraint (Installed FCDS capacity)            | 17,145 MW  | 18,697 MW   |
| Portfolio battery storage behind the constraint (Installed FCDS capacity)      | 5,770 MW   | 5,808 MW    |
| Deliverable portfolio resources w/o mitigation (Installed FCDS capacity)       | 12,610 MW  | 12,009 MW   |
| Total undeliverable baseline and portfolio resources (Installed FCDS capacity) | 4,535 MW   | 6,688 MW    |

|                        |                                     |   |
|------------------------|-------------------------------------|---|
| Mitigation Options     | RAS                                 | Not sufficient  |
|                        | Reduce generic battery storage (MW) | Not applicable  |
|                        | Transmission upgrade including cost | 1. Trout Canyon – Lugo 500kV Line (\$2 B)<br>2. Marketplace-Adelanto AC-DC Conversion<br>3. Western Bounty HVDC |
| Recommended Mitigation |                                     | TBD   |

| Affected inerties                          | MEAD ITC, BLYTHE ITC |             |
|--|----------------------|-------------|
|  | Base                 | Sensitivity |
| MIC expansion request MW behind constraint | 282                  | 282         |
| Deliverable MIC expansion request MW       | 0                    | 0           |

### F.12.4 Wyoming Wind Sensitivity Study

The overloads in 2039 were largely driven by the out-of-state wind resources and load increase when comparing to 2034 results. A sensitivity study was performed on the 2039 base portfolio HSN case to better understand the impact of out-of-state wind on the constraint and to evaluate the alternatives. To model the out-of-state wind resources more accurately, the CAISO added the SWIP-North and TWE AC models and relocated the 1,050 MW Idaho wind and 1,500 MW Wyoming wind from Harry Allen to Midpoint and TWE-IPP 500 kV buses respectively. For the remaining 1,500 MW Wyoming wind that required new transmission, the following HVAC and HVDC alternatives were studied:

- AC Option 1: a new TWE-IPP – Muddy – Lugo 500 kV series compensated line, inject the 1,500 MW Wyoming wind at TWE-IPP 500 kV bus
- AC Option 2: a new 500 kV series compensated line from TWE-IPP to Eldorado and a new Trout Canyon – Lugo 500 kV series compensated line; inject the 1,500 MW Wyoming wind at TWE-IPP 500 kV bus
- DC Option 1: HVDC line from Wyoming to Lugo; inject the 1,500 MW Wyoming wind at Lugo 500 kV bus
- DC Option 2 (same as policy study): DC line from Wyoming to Eldorado, requires Trout Canyon – Lugo or Muddy – Lugo 500 kV line based on the policy study result

In addition, Marketplace – Adelanto HVDC conversion project and West Bounty Project were also evaluated as potential mitigations to the Lugo – Victorville constraint.

The results of each alternative are provided in the following tables:



Table F.12-14: AC Option 1 Result (TWE-IPP – Muddy, Muddy – Lugo)

| Overloaded Facility                          | Contingency                                      | 2039 Base HSN Loading (%) | AC Option 1 (%) |
|--|--|---------------------------|-----------------|
| Gamebird 230/138 kV Transformer              | Trout Canyon – Sloan Canyon 500kV Nos. 1&2 lines | 148                       | 147             |
| Gamebird – Sandy 138 kV Line                 |  | 128                       | 126             |
| Sandy – Amargosa 138 kV Line                 |  | 147                       | 145             |
| Amargosa 230/138 kV Transformer              |  | 110                       | 109             |
| VEA PST – IS Tap – Northwest 138 kV Tie Line |  | 138                       | 137             |
| VEA PST – IS Tap – Northwest 138 kV Tie Line | Northwest – Desert View 230kV Nos. 1&2 lines     | 119                       | 120             |
|  | Innovation – Desert View 230kV Nos. 1&2 lines    | 109                       | 111             |
| Eldorado – McCullough 500 kV Line            | Eldorado – Lugo 500kV line                       | 156                       | 105             |
|  | Lugo – Mohave 500kV line                         | 141                       | 99              |
| Lugo – Victorville 500 kV Line               | Base Case  | 112                       | <95             |
|  | Eldorado – Lugo 500kV line                       | 127                       | <95             |
|  | Lugo – Mohave 500kV line                         | 117                       | <95             |
|  | Eldorado – Mohave 500kV line                     | 101                       | <95             |
| Eldorado – Lugo 500 kV Line                  | Lugo – Victorville 500kV line                    | 111                       | <95             |

Table F.12-15: AC Option 2 Result (TWE-IPP – Eldorado, Trout Canyon - Lugo)

| Overloaded Facility                          | Contingency                                      | 2039 Base HSN Loading (%) | AC Option 2 (%) |
|--|--|---------------------------|-----------------|
| Gamebird 230/138 kV Transformer              | Trout Canyon – Sloan Canyon 500kV Nos. 1&2 lines | 148                       | <95             |
| Gamebird – Sandy 138 kV Line                 |  | 128                       | <95             |
| Sandy – Amargosa 138 kV Line                 |  | 147                       | <95             |
| Amargosa 230/138 kV Transformer              |  | 110                       | <95             |
| VEA PST – IS Tap – Northwest 138 kV Tie Line |  | 138                       | <95             |
| VEA PST – IS Tap – Northwest 138 kV Tie Line | Northwest – Desert View 230kV Nos. 1&2 lines     | 119                       | <95             |
|  | Innovation – Desert View 230kV Nos. 1&2 lines    | 109                       | <95             |
| Eldorado – McCullough 500 kV Line            | Eldorado – Lugo 500kV line                       | 156                       | 102             |
|  | Lugo – Mohave 500kV line                         | 141                       | <95             |
| Lugo – Victorville 500 kV Line               | Base Case  | 112                       | <95             |
|  | Eldorado – Lugo 500kV line                       | 127                       | <95             |
|  | Lugo – Mohave 500kV line                         | 117                       | <95             |
|  | Eldorado – Mohave 500kV line                     | 101                       | <95             |
| Eldorado – Lugo 500 kV Line                  | Lugo – Victorville 500kV line                    | 111                       | <95             |

Table F.12-16: DC Option 1 Result (DC from Wyoming to Lugo)

| Overloaded Facility                          | Contingency                                      | 2039 Base HSN Loading (%) | DC Option1 (%) |
|--|--|---------------------------|----------------|
| Gamebird 230/138 kV Transformer              | Trout Canyon – Sloan Canyon 500kV Nos. 1&2 lines | 148                       | 148            |
| Gamebird – Sandy 138 kV Line                 |  | 128                       | 128            |
| Sandy – Amargosa 138 kV Line                 |  | 147                       | 147            |
| Amargosa 230/138 kV Transformer              |  | 110                       | 111            |
| VEA PST – IS Tap – Northwest 138 kV Tie Line |  | 138                       | 138            |
| VEA PST – IS Tap – Northwest 138 kV Tie Line | Northwest – Desert View 230kV Nos. 1&2 lines     | 119                       | 118            |
|  | Innovation – Desert View 230kV Nos. 1&2 lines    | 109                       | 108            |
| Eldorado – McCullough 500 kV Line            | Eldorado – Lugo 500kV line                       | 156                       | 132            |
|  | Lugo – Mohave 500kV line                         | 141                       | 120            |
| Lugo – Victorville 500 kV Line               | Base Case  | 112                       | 100            |
|  | Eldorado – Lugo 500kV line                       | 127                       | 113            |
|  | Lugo – Mohave 500kV line                         | 117                       | 105            |
|  | Eldorado – Mohave 500kV line                     | 101                       | <95            |
| Eldorado – Lugo 500 kV Line                  | Lugo – Victorville 500kV line                    | 111                       | 99             |

Based on the initial result, while injecting the additional 1,500 MW Wyoming wind to Lugo instead of Eldorado reduced the overloads on Lugo – Victorville and Eldorado – McCullough lines, it alone could not fully mitigate the overloads and RAS was still not sufficient in this case. Other transmission solutions, like Trout Canyon – Lugo or Muddy – Lugo 500 kV line are still needed.

Table F.12-17: DC Option 1 plus Trout Canyon – Lugo or Muddy – Lugo Result

| Overloaded Facility                          | Contingency                                      | DC Option1 +Trout-Lugo (%) | DC Option1 +Muddy-Lugo (%) |
|--|--|----------------------------|----------------------------|
| Gamebird 230/138 kV Transformer              | Trout Canyon – Sloan Canyon 500kV Nos. 1&2 lines | <95                        | 147                        |
| Gamebird – Sandy 138 kV Line                 |  | <95                        | 125                        |
| Sandy – Amargosa 138 kV Line                 |  | <95                        | 143                        |
| Amargosa 230/138 kV Transformer              |  | <95                        | 108                        |
| VEA PST – IS Tap – Northwest 138 kV Tie Line |  | <95                        | 136                        |
| VEA PST – IS Tap – Northwest 138 kV Tie Line | Northwest – Desert View 230kV Nos. 1&2 lines     | <95                        | 122                        |
|  | Innovation – Desert View 230kV Nos. 1&2 lines    | <95                        | 112                        |
| Eldorado – McCullough 500 kV Line            | Eldorado – Lugo 500kV line                       | <95                        | 96                         |
|  | Lugo – Mohave 500kV line                         | <95                        | <95                        |
| Lugo – Victorville 500 kV Line               | Base Case  | <95                        | <95                        |
|  | Eldorado – Lugo 500kV line                       | <95                        | <95                        |
|  | Lugo – Mohave 500kV line                         | <95                        | <95                        |

| Overloaded Facility         | Contingency                   | DC Option1<br>+Trout-Lugo<br>(%) | DC Option1<br>+Muddy-Lugo<br>(%) |
|-----------------------------|-------------------------------|----------------------------------|----------------------------------|
|                             | Eldorado – Mohave 500kV line  | <95                              | <95                              |
| Eldorado – Lugo 500 kV Line | Lugo – Victorville 500kV line | <95                              | <95                              |

Table F.12-18: DC Option 2 Result (DC from Wyoming to Eldorado)

| Overloaded Facility                             | Contingency   | 2039 Base<br>HSN Loading<br>(%) | DC Option2+<br>Trout-Lugo<br>(%) |
|---|---|---------------------------------|----------------------------------|
| Gamebird 230/138 kV Transformer                 | Trout Canyon – Sloan Canyon 500kV Nos. 1&2<br>lines | 148                             | <95                              |
| Gamebird – Sandy 138 kV Line                    |   | 128                             | <95                              |
| Sandy – Amargosa 138 kV Line                    |   | 147                             | <95                              |
| Amargosa 230/138 kV Transformer                 |   | 110                             | <95                              |
| VEA PST – IS Tap – Northwest 138 kV<br>Tie Line |   | 138                             | <95                              |
| VEA PST – IS Tap – Northwest 138 kV<br>Tie Line | Northwest – Desert View 230kV Nos. 1&2 lines        | 119                             | <95                              |
|   | Innovation – Desert View 230kV Nos. 1&2 lines       | 109                             | <95                              |
| Eldorado – McCullough 500 kV Line               | Eldorado – Lugo 500kV line                          | 156                             | 103                              |
|   | Lugo – Mohave 500kV line                            | 141                             | 97                               |
| Lugo – Victorville 500 kV Line                  | Base Case   | 112                             | <95                              |
|   | Eldorado – Lugo 500kV line                          | 127                             | <95                              |
|   | Lugo – Mohave 500kV line                            | 117                             | <95                              |
|   | Eldorado – Mohave 500kV line                        | 101                             | <95                              |
| Eldorado – Lugo 500 kV Line                     | Lugo – Victorville 500kV line                       | 111                             | <95                              |

### Marketplace – Adelanto HVDC Conversion Project (MAP)

The project was proposed to convert the marketplace – Adelanto transmission line from its existing HVAC operation to HVDC operation. It would increase the usable transmission capacity on the existing MAP path from its current level of 1,296 MW to 3,500 MW of bi-directional capacity. According to Lotus Infrastructure Partners estimate, approximately 1,800 – 2,200 MW associated with MAP upgrade would be available to the CAISO. As part of the project scope, two options were proposed to integrate the new capacity into the bulk transmission network: option 1 would build a 500 kV Llano switchyear looping into Lugo – Vincent 500 kV lines, build two new 17 miles 500 kV single circuit lines from Llano to Adelanto converter station and tentatively install one 30 ohm series reactor between Adelanto converter station and Adelanto substation for flow balancing; option 2 would construct two new 16 miles 500 kV single circuit lines from Adelanto converter station to Lugo 500 kV bus without the need for series reactor.

The Wyoming wind sensitivity study assumed 1,800 MW of capacity increase would be available to the CAISO. The additional 1,500 MW Wyoming wind was modeled at Eldorado 500 kV bus. The results are shown in the table below.

Table F.12-19: Marketplace – Adelanto HVDC Conversion Project (MAP) Results

| Overloaded Facility                          | Contingency                                      | 2039 Base HSN Loading (%) | MAP Alt 1 (%) | MAP Alt 2 (%) |
|--|--|---------------------------|---------------|---------------|
| Gamebird 230/138 kV Transformer              | Trout Canyon – Sloan Canyon 500kV Nos. 1&2 lines | 148                       | 148           | 148           |
| Gamebird – Sandy 138 kV Line                 |  | 128                       | 128           | 128           |
| Sandy – Amargosa 138 kV Line                 |  | 147                       | 147           | 147           |
| Amargosa 230/138 kV Transformer              |  | 110                       | 111           | 111           |
| VEA PST – IS Tap – Northwest 138 kV Tie Line |  | 138                       | 139           | 139           |
| VEA PST – IS Tap – Northwest 138 kV Tie Line | Northwest – Desert View 230kV Nos. 1&2 lines     | 119                       | 116           | 116           |
|  | Innovation – Desert View 230kV Nos. 1&2 lines    | 109                       | 106           | 106           |
| Eldorado – McCullough 500 kV Line            | Eldorado – Lugo 500kV line                       | 156                       | 101           | 101           |
|  | Lugo – Mohave 500kV line                         | 141                       | <95           | 96            |
| Lugo – Victorville 500 kV Line               | Base Case  | 112                       | <95           | <95           |
|  | Eldorado – Lugo 500kV line                       | 127                       | <95           | <95           |
|  | Lugo – Mohave 500kV line                         | 117                       | <95           | <95           |
|  | Eldorado – Mohave 500kV line                     | 101                       | <95           | <95           |
| Eldorado – Lugo 500 kV Line                  | Lugo – Victorville 500kV line                    | 111                       | <95           | <95           |

### Western Bounty Transmission System

The project was submitted as an interregional transmission project and requested an evaluation in the 2024-2025 TPP. The project proposed a three segmented 500- to 800-kV HVDC transmission system connecting renewable energy resources near Western Bounty’s Hub Auriga Converter Substation in Esmeralda County, NV to termini in southern California, central Oregon and southwestern Idaho. The segment to southern California consists of two HVDC circuits: Path 1 from Auriga to a proposed new substation looping into SCE’s Lugo – Vincent 500 kV lines, Path 2 from Auriga to LADWP’s Adelanto substation. Each path has a bidirectional capacity of 3,000 MW. For the purpose of this study, we focused on evaluating the impact of Path 1 and Path 2 with a loading of 3,000 MW. The additional 1,500 MW Wyoming wind was modeled at Eldorado 500 kV bus. The results are summarized in the table below.

Table F.12-20: Western Bounty Transmission System Results

| Overloaded Facility             | Contingency                                      | 2039 Base HSN Loading (%) | West Bounty Path 1 (%) | West Bounty Path 1 and 2 (%) |
|---------------------------------|--|---------------------------|------------------------|------------------------------|
| Gamebird 230/138 kV Transformer | Trout Canyon – Sloan Canyon 500kV Nos. 1&2 lines | 148                       | 143                    | 143                          |

|  |   |     |     |     |
|--|---|-----|-----|-----|
| Gamebird – Sandy 138 kV Line                 |   | 128 | 119 | 119 |
| Sandy – Amargosa 138 kV Line                 |   | 147 | 136 | 136 |
| Amargosa 230/138 kV Transformer              |   | 110 | 102 | 102 |
| VEA PST – IS Tap – Northwest 138 kV Tie Line |   | 138 | 127 | 127 |
| VEA PST – IS Tap – Northwest 138 kV Tie Line | Northwest – Desert View 230kV Nos. 1&2 lines  | 119 | 133 | 132 |
|  | Innovation – Desert View 230kV Nos. 1&2 lines | 109 | 123 | 123 |
| Eldorado – McCullough 500 kV Line            | Eldorado – Lugo 500kV line                    | 156 | 120 | 115 |
|  | Lugo – Mohave 500kV line                      | 141 | 113 | 107 |
| Lugo – Victorville 500 kV Line               | Base Case                                     | 112 | <95 | 111 |
|  | Eldorado – Lugo 500kV line                    | 127 | <95 | 119 |
|  | Lugo – Mohave 500kV line                      | 117 | <95 | 112 |
|  | Eldorado – Mohave 500kV line                  | 101 | <95 | 98  |
| Eldorado – Lugo 500 kV Line                  | Lugo – Victorville 500kV line                 | 111 | <95 | 96  |

Based on the Wyoming wind sensitivity study results discussed above, a few conclusions could be made:

- Under all HVAC and HVDC alternatives to bring in the additional 1,500 MW Wyoming wind to CAISO footprint, additional transmission upgrade is needed to mitigate Lugo – Victorville and Eldorado – McCullough constraints.
- The Trout Canyon – Lugo 500 kV line, Muddy – Lugo 500 kV line, MAP Upgrade Project and Western Bounty Path 1 are all able to mitigate Lugo – Victorville overloads.
- Trout Canyon – Lugo 500 kV line can also mitigate all of the identified GLW overloads and eliminate the use of RAS, while the other options still require the RAS.
- Except the HVDC line from Wyoming to Lugo along with the Trout Canyon – Lugo 500 kV line option, all the other alternatives studied cannot fully mitigate Eldorado – McCullough overloads. RAS can be utilized to mitigate the overload or the potential Eldorado 500 kV SCD mitigation may also eliminate this constraint.
- The HVDC line from Wyoming to Lugo along with the Trout Canyon – Lugo 500 kV line can eliminate all the EOP overloads identified under 2039 base portfolio.
- The two AC upgrade options proposed in MAP Upgrade Project yield similar results
- Western Bounty Path 1 by itself would eliminate the Lugo – Victorville constraint. But Path 2 would exacerbate it. When both Path 1 and Path 2 are energized, it would not fully mitigate the Lugo – Victorville overloads.

### F.12.5 Conclusion and recommendation

The SCE and GLW East of Pisgah area deliverability assessment identifies several on peak deliverability constraints in both base and sensitivity portfolios. The mitigations include curtailing MIC expansion request, relying on the existing RAS and the future planned RAS.

MIC expansion request on the MEAD\_ITC intertie is behind the Eldorado – McCullough constraint and none of the 114 MW of MIC expansion request is deliverable. Both MEAD\_ITC and BLYTHE\_ITC interties are behind the Lugo – Victorville constraint. The 282 MW of MIC expansion request is deliverable in 2034, but none is deliverable in 2039.

The CAISO also performed a sensitivity study to evaluate different alternatives to import the additional 1,500 MW Wyoming wind beyond TransWest Express capacity and to mitigate Lugo – Victorville constraint. To be consistent with the CPUC directive in the Proposed Decision not to trigger upgrades related to the additional OOS wind amounts in the portfolio that are beyond the amounts that can be accommodated on the already-identified and in-development transmission upgrades, the CAISO will keep evaluating potential transmission upgrades and will not recommend for approval of any in the current TPP cycle.

### F.13 SCE Northern Area

The total capacity of resources, by resource type, selected with Full Capacity Deliverability Status (FCDS) as well as those selected as Energy Only (EO) in the SCE Northern interconnection area are listed in Table F.13-1. The portfolios in the interconnection area are comprised of solar, wind (in-state), battery storage, long duration energy storage, biomass/biogas and distributed solar resources. All portfolio resources are modeled in policy-driven assessments except in the on-peak deliverability assessment in which only FCDS resources are modeled.

Table F.13-1: SCE Northern Interconnection Area – Base and Sensitivity Portfolios by Resource Types (FCDS, EO and Total)

| Resource Type                       | 2034 Base Portfolio |              |              | 2039 Base Portfolio |              |              | 2039 Sensitivity Portfolio |              |               |
|-------------------------------------|---------------------|--------------|--------------|---------------------|--------------|--------------|----------------------------|--------------|---------------|
|                                     | FCDS (MW)           | EO (MW)      | Total (MW)   | FCDS (MW)           | EO (MW)      | Total (MW)   | FCDS (MW)                  | EO (MW)      | Total (MW)    |
| Solar                               | 1,653               | 2,093        | 3,746        | 1,654               | 3,057        | 4,711        | 3,259                      | 5,107        | 8,366         |
| Wind – In State                     | 564                 | 16           | 580          | 564                 | 16           | 580          | 514                        | 16           | 530           |
| Wind – Out-of-State                 | 0                   | 0            | 0            | 0                   | 0            | 0            | 0                          | 0            | 0             |
| Wind - Offshore                     | 0                   | 0            | 0            | 0                   | 0            | 0            | 0                          | 0            | 0             |
| Li Battery – 4 hr                   | 3,735               | 0            | 3,735        | 3,485               | 0            | 3,485        | 2,610                      | 0            | 2,610         |
| Li Battery – 8 hr                   | 170                 | 0            | 170          | 734                 | 0            | 734          | 2,294                      | 0            | 2,294         |
| Long Duration Energy Storage (LDES) | 458                 | 0            | 458          | 458                 | 0            | 458          | 500                        | 0            | 500           |
| Geothermal                          | 0                   | 0            | 0            | 0                   | 0            | 0            | 0                          | 0            | 0             |
| Biomass/Biogas                      | 1                   | 0            | 1            | 1                   | 0            | 1            | 0                          | 0            | 0             |
| Distributed Solar                   | 5                   | 0            | 5            | 5                   | 0            | 5            | 8                          | 0            | 8             |
| <b>Total</b>                        | <b>6,586</b>        | <b>2,109</b> | <b>8,695</b> | <b>6,901</b>        | <b>3,073</b> | <b>9,974</b> | <b>9,185</b>               | <b>5,123</b> | <b>14,308</b> |

Table F.13-2 shows adjustments to the portfolios in the SCE Northern Interconnection Area made with CPUC staff guidance to account for additional in-development resources modeled by the PTO based on the project status.

Table F.13-2: SCE Northern Interconnection Area – Modifications to the portfolios to account for adjustments to in-development resources

| Substation  | Voltage | Resource Type | 2034 Base Portfolio |            |            | 2039 Base Portfolio |           |            | 2039 Sensitivity Portfolio |           |            |
|-------------|---------|---------------|---------------------|------------|------------|---------------------|-----------|------------|----------------------------|-----------|------------|
|             |         |               | FCDS (MW)           | EODS (MW)  | Total (MW) | FCDS (MW)           | EODS (MW) | Total (MW) | FCDS (MW)                  | EODS (MW) | Total (MW) |
| Windhub     | 230     | Li Battery    | 375                 | -          | 375        | 125                 | -         | 125        | 250                        | -         | 250        |
| Windhub     | 230     | Solar         | -                   | 400        | 400        | -                   | -         | -          | -                          | -         | -          |
| Windhub     | 66      | Solar         | 20                  | -          | 20         | 20                  | -         | 20         | 20                         | -         | 20         |
| Rector      | 66      | Li Battery    | 80                  | -          | 80         | 80                  | -         | 80         | 80                         | -         | 80         |
| Springville | 66      | Solar         | -                   | 40         | 40         | -                   | 40        | 40         | -                          | 40        | 40         |
| Springville | 66      | Li Battery    | 40                  | -          | 40         | 40                  | -         | 40         | 40                         | -         | 40         |
|             |         |               | <b>515</b>          | <b>440</b> | <b>955</b> | <b>265</b>          | <b>40</b> | <b>305</b> | <b>390</b>                 | <b>40</b> | <b>430</b> |

The 2034 Base Portfolio resources, as identified in the CPUC busbar mapping for the SCE Northern interconnection area, are illustrated on the single-line diagram in Figure F.13-1.

Figure F.13-1: SCE Northern Interconnection Area – Mapped<sup>18</sup> 2034 Base Portfolio

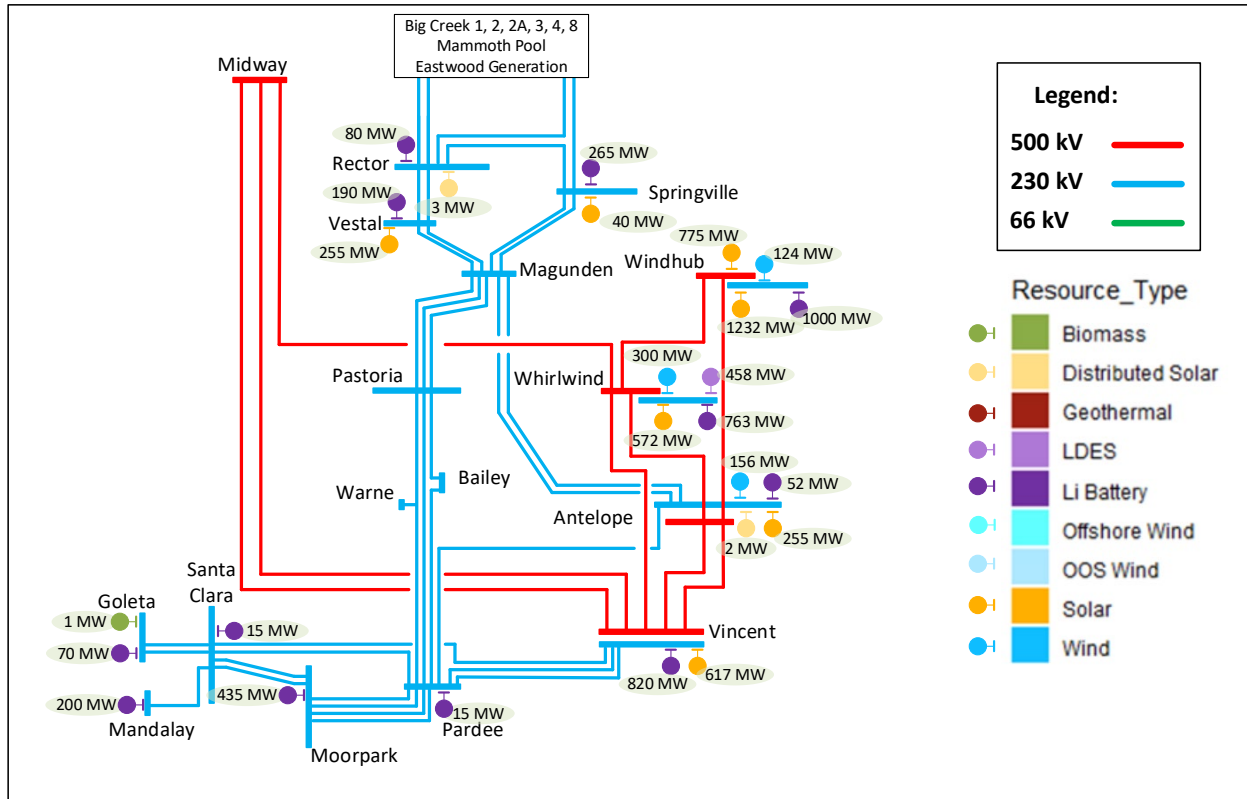

<sup>18</sup> Mapped base portfolio includes the adjustments to the base portfolio made by CPUC staff in the SCE Northern Interconnection Area to account for additional in-development resources identified.



The 2039 Base Portfolio resources, as identified in the CPUC busbar mapping for the SCE Northern interconnection area, are illustrated on the single-line diagram in Figure F.13-2.

Figure F.13-2: SCE Northern Interconnection Area – Mapped<sup>19</sup> 2039 Base Portfolio

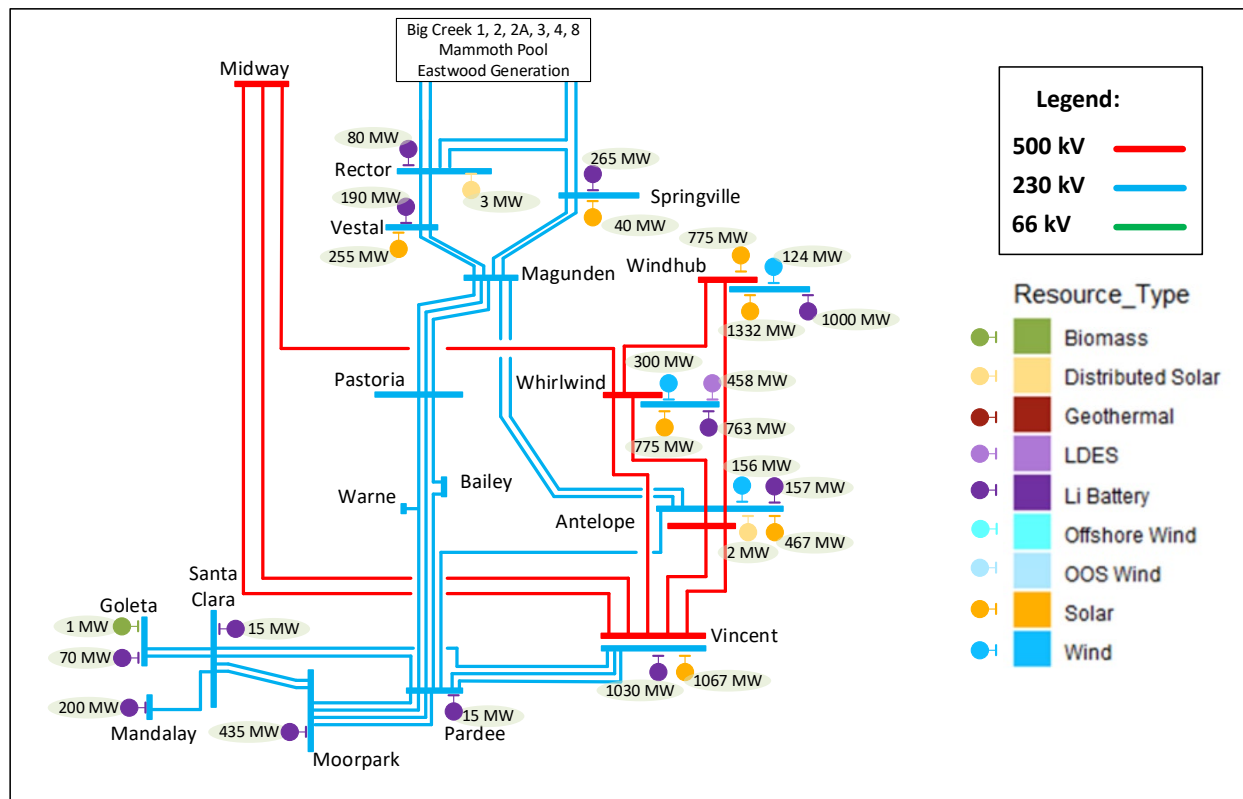

### F.13.1 2034 On-peak results

#### Windhub 500/230 kV Transformer Constraint

The deliverability of FC resources interconnecting at Windhub 230 kV buses is limited by thermal overloading of the 500/230 kV transformers under Category P1 conditions as shown in Table F.13-3. The constraint is identified in the base portfolio under the HSN condition, where 752 MW of capacity resources interconnecting at Bus A, will be undeliverable without mitigation as shown in Table F.13-4. The constraint can be mitigated by the existing Windhub AA Bank CRAS.

<sup>19</sup> Mapped base portfolio includes the adjustments to the base portfolio made by CPUC staff in the SCE Northern Interconnection Area to account for additional in-development resources identified.

Table F.13-3: Windhub 500/230 kV transformer deliverability constraint

| Overloaded Facility                | Contingency                       | Loading (%) |       |
|------------------------------------|-----------------------------------|-------------|-------|
|                                    |                                   | HSN         | SSN   |
| Windhub #1 500/230 kV transformer* | Windhub #2 500/230 kV transformer | 135         | < 100 |
| Windhub #2 500/230 kV transformer* | Windhub #1 500/230 kV transformer | 135         | < 100 |

\* The loading on the transformers depends on which Windhub 230 kV bus, Bus A or Bus B, generic portfolio resources are mapped to, could overload Banks #3 and #4 500/230 kV transformers.

Table F.13-4: Windhub #1 and #2 500/230 kV transformer constraint summary

|  |  |                                       |
|--|--|---------------------------------------|
| Affected transmission zones  |  | Tehachapi area – Windhub 230 kV Bus A |
| Portfolio resources behind the constraint (Installed FCDS capacity)            |  | 1373 MW                               |
| Portfolio battery storage behind the constraint (Installed FCDS capacity)      |  | 1016 MW                               |
| Deliverable portfolio resources w/o mitigation (Installed FCDS capacity)       |  | 621 MW                                |
| Total undeliverable baseline and portfolio resources (Installed FCDS capacity) |  | 752 MW                                |
| Mitigation Options   | RAS                                      | Existing Windhub AA Bank CRAS         |
|  | Re-locate portfolio battery storage (MW) | Not needed                            |
|  | Transmission upgrade including cost      | Not Needed                            |
| Recommended Mitigation   |  | Existing Windhub AA Bank CRAS         |

Table F.13-5: Windhub #1 and #2 500/230 kV transformer constraint affected inerties

|  |     |     |
|--|-----|-----|
| Affected inerties                          | N/A |     |
| MIC expansion request MW behind constraint | N/A | N/A |
| Deliverable MIC expansion request MW       |     |     |

### Whirlwind 500/230 kV Transformer Constraint

The deliverability of FC resources interconnecting at Whirlwind 230 kV bus is limited by thermal overloading of the 500/230 kV transformers under Category P1 conditions as shown in Table F.13-6. The constraint is identified in the base portfolio under the SSN condition, where 106 MW of capacity resources will be undeliverable without mitigation as shown in Table F.13-7. The constraint can be mitigated by the planned Whirlwind AA Bank CRAS.

Table F.13-6: Whirlwind 500/230 kV transformer deliverability constraint

| Overloaded Facility                 | Contingency                               | Loading (%) |     |
|-------------------------------------|---|-------------|-----|
|                                     |   | HSN         | SSN |
| Whirlwind #1 500/230 kV transformer | Whirlwind #3 or #4 500/230 kV transformer | < 100       | 102 |
| Whirlwind #3 500/230 kV transformer | Whirlwind #1 or #4 500/230 kV transformer | < 100       | 102 |
| Whirlwind #4 500/230 kV transformer | Whirlwind #1 or #3 500/230 kV transformer | < 100       | 102 |

Table F.13-7: Whirlwind 500/230 kV transformer constraint summary

|  |  |                                   |
|--|--|-----------------------------------|
| Affected transmission zones  |  | Tehachapi area – Whirlwind 230 kV |
| Portfolio resources behind the constraint (Installed FCDS capacity)            |  | 1848 MW                           |
| Portfolio battery storage behind the constraint (Installed FCDS capacity)      |  | 758 MW                            |
| Deliverable portfolio resources w/o mitigation (Installed FCDS capacity)       |  | 1742 MW                           |
| Total undeliverable baseline and portfolio resources (Installed FCDS capacity) |  | 106 MW                            |
| Mitigation Options   | RAS                                      | Planned Whirlwind AA Bank CRAS    |
|  | Re-locate portfolio battery storage (MW) | Not needed                        |
|  | Transmission upgrade including cost      | Not Needed                        |
| Recommended Mitigation   |  | Planned Whirlwind AA Bank CRAS    |

Table F.13-8: Whirlwind 500/230 kV transformer constraint affected inerties

|  |     |     |
|--|-----|-----|
| Affected inerties                          | N/A |     |
| MIC expansion request MW behind constraint | N/A | N/A |
| Deliverable MIC expansion request MW       |     |     |

### Midway–Whirlwind 500 kV Line Constraint

The deliverability of FC resources interconnecting in the Tehachapi and North of Magunden areas is limited by thermal overloading of PG&E’s portion of Midway–Whirlwind 500 kV line under Category P0 condition as shown in Table F.13-9. The constraint is identified in the base portfolio under the SSN condition, where 430 MW of capacity resources will be undeliverable without mitigation as shown in

Table F.13-10. Since the constraint occurs under normal system conditions, RAS is not a viable mitigation. Additionally, the ISO explored the alternative to re-locate generic portfolio battery storage to other substations outside the affected transmission zones, but this proved to be insufficient to mitigate the thermal overload.

Finally, the ISO assessed the following transmission alternatives:

1. Bypass the series capacitor of the Midway–Whirlwind 500 kV line

Bypassing the series capacitor of the Midway–Whirlwind 500 kV line is sufficient to address the on-peak deliverability constraint for both the base case condition without contingency and with the outage of both Vincent – Midway 500 kV lines, assuming a Path 26 south to north flow of 3,000 MW. The ISO performed a reliability study to determine if the series capacitor could be bypassed permanently, seasonally or if there is a requirement of constant switching dependent on changing system conditions. The assessment showed that the series capacitor could be bypassed permanently as no reliability concerns were identified even with a Path 26 north to south flow of 4,000 MW, while relying on Path 26 RAS and the 30-minute emergency ratings of Path 26 transmission lines. This alternative would not have any cost.

The economic benefits of bypassing the series capacitor were evaluated using production cost simulation. The results, did not show economic benefits or significant reduction on renewable energy curtailment.

2. Pacific Transmission Expansion Project (PTEP)

To mitigate the thermal overload of Midway – Whirlwind 500 kV line in heavy Path 26 south to north flow conditions, the PTEP HVDC would need to transfer real power from SCE to PG&E. The main disadvantage of this alternative is that it could create a loop flow through Path 26 500 kV lines by having a south to north flow from Whirlwind to Midway and a north to south flow from Midway to Vincent if the transfer through PTEP HVDC is not adjusted correctly.

The alternative would have an estimated cost of \$1.89-\$2.32 billion. The economic benefits of the PTEP was evaluated using production cost simulation. The results, which are presented in Appendix G, did not find the line to be economic at this time.

3. Upgrade Midway – Whirlwind 500 kV line

This alternative involves increasing the normal and emergency ratings of both portions of Midway – Whirlwind 500 kV line by upgrading terminal equipment, the conductor for PG&E's portion, line to ground clearance for SCE's portion, and the series capacitor. The ISO, in collaboration, with PG&E and SCE will continue to investigate the feasibility of this option.

Based on the above considerations, congestion management is found to be the preferred solution to address the on-peak deliverability constraint for the SSN scenario at this time.

Table F.13-9: Midway–Whirlwind 500 kV line deliverability constraint

| Overloaded Facility                         | Contingency | Loading (%) |     |
|---|-------------|-------------|-----|
|   |             | HSN         | SSN |
| Midway–Whirlwind 500 kV line (PG&E segment) | Base Case   | < 100       | 106 |

Table F.13-10: Midway–Whirlwind 500 kV line constraint summary

|  |  |  |
|--|--|--|
| Affected transmission zones  |  | Tehachapi and North of Magunden areas  |
| Portfolio resources behind the constraint (Installed FCDS capacity)            |  | 5165 MW  |
| Portfolio battery storage behind the constraint (Installed FCDS capacity)      |  | 2838 MW  |
| Deliverable portfolio resources w/o mitigation (Installed FCDS capacity)       |  | 4735 MW  |
| Total undeliverable baseline and portfolio resources (Installed FCDS capacity) |  | 430 MW   |
| Mitigation Options   | RAS                                      | Not applicable for P0 overload   |
|  | Re-locate portfolio battery storage (MW) | Not sufficient   |
|  | Transmission upgrade including cost      | <ol style="list-style-type: none"> <li>1. Bypass the series capacitor of the Midway–Whirlwind 500 kV line (No cost)</li> <li>2. PTEP (\$1.89-\$2.32 B)</li> <li>3. Upgrade Midway – Whirlwind 500 kV line</li> </ol> |
| Recommended Mitigation   |  | Congestion management  |

Table F.13-11: Midway–Whirlwind 500 kV line constraint affected inerties

|  |     |     |
|--|-----|-----|
| Affected inerties                          | N/A |     |
| MIC expansion request MW behind constraint | N/A | N/A |
| Deliverable MIC expansion request MW       |     |     |

**F.13.2 2034 Off-peak results**

Wind and solar resources in the SCE Northern area are subject to curtailment in the base portfolio due to loading constraints identified in Table F.13-12 under normal and/or contingency conditions, which are further discussed below.

Table F.13-12: SCE Northern area off-peak deliverability constraints

| Overloaded Facility                    | Contingency                       | Loading (%) |
|--|-----------------------------------|-------------|
| Windhub #1 500/230 kV transformer*     | Windhub #2 500/230 kV transformer | 140         |
| Windhub #2 500/230 kV transformer*     | Windhub #1 500/230 kV transformer | 140         |
| Midway–Whirlwind 500 kV (PG&E segment) | Base Case                         | 119         |

\* Depending on which Windhub 230 kV bus, Bus A or Bus B, generic portfolio resources are mapped to, could overload Banks #3 and #4 500/230 kV transformers.

### Windhub 500/230 kV transformers off-peak deliverability constraint

Wind and solar resources interconnecting to Windhub 230 kV Bus A are subject to curtailment in the base portfolio due to loading limitations of the Windhub 500/230 kV transformers under Category P1 conditions, as shown above. About 728 MW of portfolio resources were curtailed to mitigate the overload as presented in Table F.13-13. Pre-contingency curtailment can be avoided by relying on the existing Windhub AA Bank CRAS.

Table F.13-13: Windhub 500/230 kV transformers off-peak deliverability constraint summary

|  |   |                                       |
|--|---|---------------------------------------|
| Affected renewable transmission zones                    |   | Tehachapi area – Windhub 230 kV Bus A |
| Portfolio solar and wind resources behind the constraint |   | 1382 MW                               |
| Portfolio energy storage behind the constraint           |   | 1016 MW                               |
| Renewable curtailment without mitigation                 |   | 728 MW                                |
| Mitigation Options                                       | Portfolio ES (in charging mode) <sup>20</sup> | 572 MW                                |
|  | RAS   | Existing Windhub AA Bank CRAS         |
|  | Transmission upgrades                         | Not needed                            |
| Recommended Mitigation                                   |   | Existing Windhub AA Bank CRAS         |

### Midway–Whirlwind 500 kV line off-peak deliverability constraint

Wind and solar resources in the Tehachapi and North of Magunden areas are subject to curtailment in the base portfolio due to loading limitations on PG&E's portion of the Midway–Whirlwind 500 kV line under normal conditions, as shown above. About 1258 MW of portfolio resources were curtailed to mitigate the overload as presented in Table F.13-14. The constraint occurs during periods of high renewable output and heavy south to north transfers on Path 26. Renewable curtailment can be avoided by reducing thermal generation and dispatching baseline energy storage in charging mode. Since the constraint occurs under normal system conditions, RAS is not a viable mitigation.

The transmission mitigation options studied for the off-peak deliverability constraint are described in section F.13 for the Midway – Whirlwind 500 kV line on-peak deliverability constraint. Based on the above considerations, dispatching baseline energy storage in charging mode is found to be the preferred solution to address the off-peak deliverability constraint at this time.

<sup>20</sup> The Portfolio energy storage (in charging mode) amount is the amount needed to mitigate the constraint after baseline battery storage is fully utilized.

Table F.13-14: Midway–Whirlwind 500 kV line off-peak deliverability constraint summary

|  |   |  |
|--|---|--|
| Affected renewable transmission zones                    |   | Tehachapi and North of Magunden areas  |
| Portfolio solar and wind resources behind the constraint |   | 3755 MW  |
| Portfolio energy storage behind the constraint           |   | 3202 MW  |
| Renewable curtailment without mitigation                 |   | 1258 MW  |
| Mitigation Options                                       | Portfolio ES (in charging mode) <sup>21</sup> | 0 MW   |
|  | RAS   | Not applicable for P0 overload   |
|  | Transmission upgrades                         | <ol style="list-style-type: none"> <li>1. Bypass the series capacitor of the Midway–Whirlwind 500 kV line</li> <li>2. PTEP</li> <li>3. Upgrade Midway – Whirlwind 500 kV line</li> </ol> |
| Recommended Mitigation                                   |   | Baseline energy storage in charging mode   |

**F.13.3 2039 On-peak results**

**Windhub 500/230 kV Transformer Constraint**

The deliverability of FC resources interconnecting at Windhub 230 kV buses is limited by thermal overloading of the 500/230 kV transformers under Category P1 conditions as shown in Table F.13-15. The constraint is identified in both base and sensitivity portfolios, where 745 MW of capacity resources interconnected at Bus A, will be undeliverable without mitigation as shown in Table F.13-16. The constraint can be mitigated by the existing Windhub AA Bank CRAS.

Table F.13-15: Windhub 500/230 kV transformer deliverability constraint

| Overloaded Facility                | Contingency                       | Loading (%) |             |
|------------------------------------|-----------------------------------|-------------|-------------|
|                                    |                                   | Base        | Sensitivity |
| Windhub #1 500/230 kV transformer* | Windhub #2 500/230 kV transformer | 135         | 136         |
| Windhub #2 500/230 kV transformer* | Windhub #1 500/230 kV transformer | 135         | 136         |

\* The loading on the transformers depends on which Windhub 230 kV bus, Bus A or Bus B, generic portfolio resources are mapped to, could overload Banks #3 and #4 500/230 kV transformers.

<sup>21</sup> The Portfolio energy storage (in charging mode) amount is the amount needed to mitigate the constraint after baseline battery storage is fully utilized.



Table F.13-16: Windhub #1 and #2 500/230 kV transformer constraint summary

| Affected transmission zones  |  | Tehachapi area – Windhub 230 kV Bus A |             |
|--|--|---------------------------------------|-------------|
|  |  | Base                                  | Sensitivity |
| Portfolio resources behind the constraint (Installed FCDS capacity)            |  | 1368 MW                               |             |
| Portfolio battery storage behind the constraint (Installed FCDS capacity)      |  | 1012 MW                               |             |
| Deliverable portfolio resources w/o mitigation (Installed FCDS capacity)       |  | 623 MW                                |             |
| Total undeliverable baseline and portfolio resources (Installed FCDS capacity) |  | 745 MW                                |             |
| Mitigation Options   | RAS                                      | Existing Windhub AA Bank CRAS         |             |
|  | Re-locate portfolio battery storage (MW) | Not needed                            |             |
|  | Transmission upgrade including cost      | Not Needed                            |             |
| Recommended Mitigation   |  | Existing Windhub AA Bank CRAS         |             |

Table F.13-17: Windhub #1 and #2 500/230 kV transformer constraint affected inerties

| Affected inerties                          | N/A |     |
|--|-----|-----|
| MIC expansion request MW behind constraint | N/A | N/A |
| Deliverable MIC expansion request MW       |     |     |

**Windhub Area Export Constraint**

The deliverability of FC resources interconnecting at Windhub Substation is limited by the simultaneous or overlapping outage of Antelope – Windhub 500kV Line and Whirlwind – Windhub 500 kV Line without time for system adjustments, which results in islanding of the Windhub System and the consequential loss of 3000 to 6000 MW of generation.

The loss of one Windhub 500 kV line results in exposing the entire ISO and surrounding areas to voltage collapse-driven cascading outages for loss of the second Windhub 500 kV line in the Cluster 13 and Cluster 14 studies. This results in the need to immediately curtail up to 5000 MW of generation, or cascading outages if the second contingency occurs before the generation can be curtailed. Therefore, an area deliverability constraint has been enforced to address this voltage collapse and loss of resource issue.

The constraint is identified in the sensitivity portfolio, where 65 MW of capacity resources would be undeliverable without mitigation as shown in Table F.13-18. **Error! Reference source not found.** The recommended mitigation for the sensitivity portfolio is to relocate at least 65 MW of generic battery energy storage to other substations.

Table F.13-18: Windhub Area Export constraint summary

| Affected transmission zones  |  | Tehachapi area – Windhub |   |
|--|--|--------------------------|---|
|  |  | Base                     | Sensitivity                                 |
| Portfolio resources behind the constraint (Installed FCDS capacity)            |  | 2142 MW                  | 2338 MW                                     |
| Portfolio battery storage behind the constraint (Installed FCDS capacity)      |  | 1012 MW                  | 1154 MW                                     |
| Deliverable portfolio resources w/o mitigation (Installed FCDS capacity)       |  | 2142 MW                  | 2273 MW                                     |
| Total undeliverable baseline and portfolio resources (Installed FCDS capacity) |  | 0 MW                     | 65 MW                                       |
| Mitigation Options   | RAS                                      | Not applicable           |   |
|  | Re-locate portfolio battery storage (MW) | Not needed               | Relocate at least 65 MW of generic storage  |
|  | Transmission upgrade including cost      | Not Needed               | New Whirlwind-Windhub 500 kV line (\$612 M) |
| Recommended Mitigation   |  | Not Needed               | Relocate at least 65 MW of generic storage  |

**F.13.4 Conclusion and recommendation**

The SCE Northern area base and sensitivity portfolios deliverability assessment identified on-peak and off-peak deliverability constraints. The Windhub and Whirlwind 500/230 kV transformer constraints can be addressed by using CRAS. The Windhub area export constraint identified in the 2039 sensitivity portfolio can be mitigated by relocating at least 65 MW of generic battery energy storage to other substations. Several alternatives to mitigate the Midway-Whirlwind 500 kV line constraint were evaluated, but the economic assessment did not show sufficient economic benefits to reduce the Path 26 congestion or renewable energy curtailment. In consequence, transmission upgrades were not found to be needed in the area in the current planning cycle.

## F.14 SCE North of Lugo Area

Base portfolio resources, by resource type, selected with Full Capacity Deliverability Status (FCDS) as well as those selected as Energy Only (EO) in the SCE North of Lugo (NOL) interconnection area are listed in Table F.14-1. The portfolio in the interconnection area are comprised of solar, battery storage, geothermal, biomass/biogas and distributed solar resources. All portfolio resources are modeled in policy-driven assessments except in the on-peak deliverability assessment in which only FCDS resources are modeled.

Table F.14-1: SCE North of Lugo Interconnection Area – Base and Sensitivity Portfolios by Resource Types (FCDS, EO and Total)

| Resource Type                       | 2034 Base Portfolio |            |              | 2039 Base Portfolio |              |              | 2039 Sensitivity Portfolio |              |              |
|-------------------------------------|---------------------|------------|--------------|---------------------|--------------|--------------|----------------------------|--------------|--------------|
|                                     | FCDS (MW)           | EO (MW)    | Total (MW)   | FCDS (MW)           | EO (MW)      | Total (MW)   | FCDS (MW)                  | EO (MW)      | Total (MW)   |
| Solar                               | 672                 | 937        | 1,609        | 752                 | 1,285        | 2,037        | 1,268                      | 1,723        | 2,991        |
| Wind – In State                     | 310                 | 50         | 360          | 310                 | 50           | 360          | 310                        | 50           | 360          |
| Wind – Out-of-State                 | 0                   | 0          | 0            | 0                   | 0            | 0            | 0                          | 0            | 0            |
| Wind - Offshore                     | 0                   | 0          | 0            | 0                   | 0            | 0            | 0                          | 0            | 0            |
| Li Battery – 4 hr                   | 770                 | 0          | 770          | 800                 | 0            | 800          | 435                        | 0            | 435          |
| Li Battery – 8 hr                   | 90                  | 0          | 90           | 265                 | 0            | 265          | 683                        | 0            | 683          |
| Long Duration Energy Storage (LDES) | 0                   | 0          | 0            | 0                   | 0            | 0            | 0                          | 0            | 0            |
| Geothermal                          | 0                   | 0          | 0            | 0                   | 0            | 0            | 454                        | 0            | 454          |
| Biomass/Biogas                      | 2                   | 0          | 2            | 2                   | 0            | 2            | 0                          | 0            | 0            |
| Distributed Solar                   | 11                  | 0          | 11           | 27                  | 0            | 27           | 34                         | 0            | 34           |
| <b>Total</b>                        | <b>1,855</b>        | <b>987</b> | <b>2,842</b> | <b>2,156</b>        | <b>1,335</b> | <b>3,491</b> | <b>3,184</b>               | <b>1,773</b> | <b>4,957</b> |

The base portfolio resources as identified in the CPUC busbar mapping for the SCE North of Lugo interconnection area are illustrated on the single-line diagram in Figure F.14-1 and Figure F.14-2 .

Figure F.14-1: SCE North of Lugo Interconnection Area – Mapped 2034 Base Portfolio

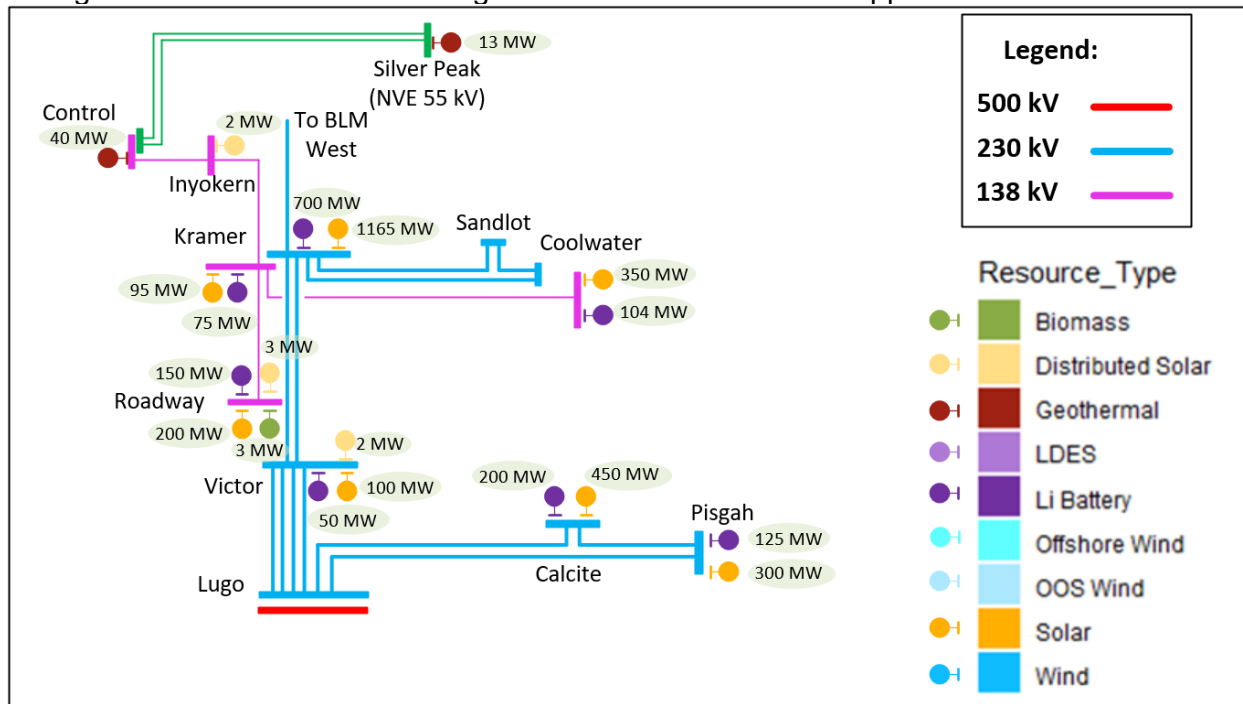
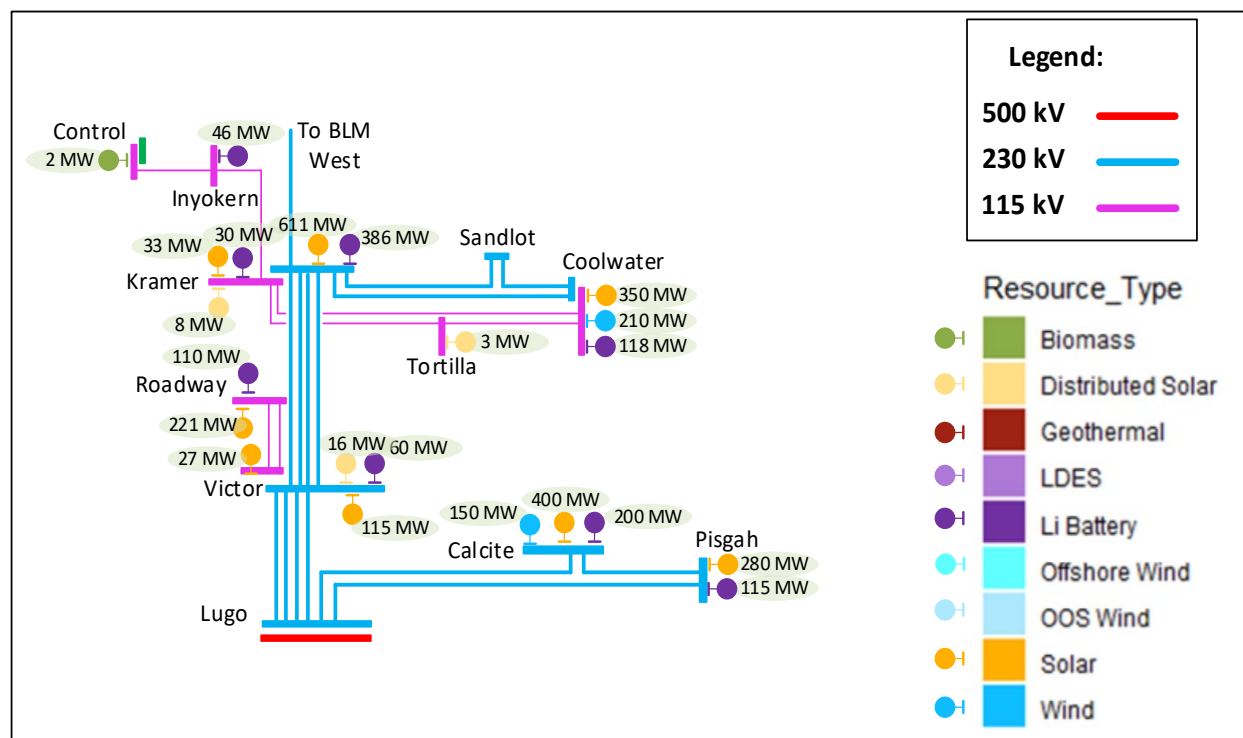

Figure F.14-2: SCE North of Lugo Interconnection Area – Mapped 2039 Base Portfolio



**F.14.1 2034 On-peak results**

**Coolwater–Kramer Corridor Constraint**

The Coolwater–Kramer corridor deliverability constraint, which is comprised of the constraints included in Table F. 14-2, affect deliverability of capacity resources in the NOL area due to thermal overloading of the planned 230/115 kV transformer and 115 kV lines in the area under contingency conditions as shown in the table. Up to 553 MW of capacity resources in the base portfolio will be undeliverable without mitigation.

Table F.14-3: On-peak Coolwater–Kramer corridor constraint summary provides the constraint summary for the more limiting constraints.

Table F.14-2: Coolwater–Kramer corridor on-peak deliverability constraint

| Overloaded Facility              | Contingency                                       | Loading (%) |     |
|----------------------------------|---|-------------|-----|
|                                  |   | HSN         | SSN |
| Coolwater 230/115 kV Transformer | Kramer–Coolwater & Kramer–Sandlot 230 kV lines    | 160         | 214 |
|                                  | Kramer–Coolwater & Sandlot–Coolwater 230 kV lines | 144         | 147 |
| Tortilla–Coolwater 115 kV        | Kramer–Coolwater & Kramer–Sandlot 230 kV lines    | 124         | 142 |
| Coolwater–Kramer 115 kV          |   | 128         | 157 |
| Sandlot- Kramer #1 230kV line    | Kramer – Coolwater #2 230kV line                  | 101         | 133 |
| Kramer – Coolwater #2 230kV line | Sandlot- Kramer #1 230kV line                     | 101         | 125 |

Table F.14-3: On-peak Coolwater–Kramer corridor constraint summary

| Affected transmission zones                    |                                     | North of Lugo Area |
|--|-------------------------------------|--------------------|
|  |                                     | <b>Base (SSN)</b>  |
| Portfolio MW behind constraint                 |                                     | 1,227 MW           |
| Portfolio battery storage MW behind constraint |                                     | 417 MW             |
| Deliverable portfolio MW w/o mitigation        |                                     | 880 MW             |
| Total undeliverable baseline and portfolio MW  |                                     | 553 MW             |
| Mitigation Options                             | RAS                                 | Mohave Desert RAS  |
|  | Reduce generic battery storage (MW) | Not needed         |
|  | Transmission upgrade including cost | Not needed         |
| Recommended Mitigation                         |                                     | Mohave Desert RAS  |

The Coolwater–Kramer corridor constraint was not found to impact MIC expansion requests as shown in Table F.14-4.

Table F.14-4: On-peak Coolwater–Kramer corridor constraint affected inerties

| Affected inerties                          | N/A |     |
|--|-----|-----|
| MIC expansion request MW behind constraint | N/A | N/A |
| Deliverable MIC expansion request MW       |     |     |

Remedial Action Schemes (RAS), reducing generic portfolio battery storage and transmission alternatives were considered to address the constraints. Since the existing Mohave Desert RAS adequately mitigates the deliverability constraints, no other solution was found to be needed.

**Control–Inyokern/Haiwee Tap 115 kV and Control Silver Peak 55 kV Constraint**

Control–Inyokern/Haiwee Tap 115 kV and Control- Silver Peak 55 kV corridor deliverability constraint described in Table F.14-5 affects deliverability of capacity resources in the NOL area due to single and double circuit outage of Control–Coso–Inyokern 115 kV lines. Up to 33 MW of capacity resources in the base portfolio will be undeliverable without mitigation. Table F.14-6 provides a summary of the constraint including affected resources and mitigation solutions.

Table F.14-5: Control–Inyokern/Haiwee Tap 115 kV on-peak deliverability constraint

| Overloaded Facility                | Contingency  | Loading (%) |     |
|------------------------------------|--|-------------|-----|
|                                    |  | HSN         | SSN |
| Control–Inyokern/Haiwee Tap 115 kV | Control–Coso–Inyokern 115 kV line  | 109         | 105 |
| Control – Silver Peak C 55kV       | Control–Coso–Haiwee–Inyokern 115 kV line & Control–Haiwee–Inyokern 115 kV line | 138         | 157 |

Table F.14-6: On-peak Control–Inyokern/Haiwee Tap 115 kV and Control Silver Peak 55 kV constraint summary

| Affected transmission zones                    | North of Inyokern Area |
|--|------------------------|
|  | <b>Base (HSN)</b>      |
| Portfolio MW behind constraint                 | 55 MW                  |
| Portfolio battery storage MW behind constraint | 0 MW                   |
| Deliverable portfolio MW w/o mitigation        | 22 MW                  |

|   |                                     |                     |
|---|-------------------------------------|---------------------|
| Total undeliverable baseline and portfolio MW |                                     | 33 MW               |
| Mitigation Options                            | RAS                                 | Existing Bishop RAS |
|   | Reduce generic battery storage (MW) | N/A                 |
|   | Transmission upgrade including cost | Not needed          |
| Recommended Mitigation                        |                                     | Existing Bishop RAS |

RAS and transmission upgrades were considered to address the constraint. Since the existing Bishop RAS adequately mitigates the deliverability constraint, no further mitigation solution was found to be needed.

The constraint was found to impact MIC expansion requests in the area as indicated in Table F.14-7.

Table F.14-7: MIC expansion requests impacted by the Control–Inyokern/Haiwee Tap and Silver Peak constraint

|  |             |
|--|-------------|
| Affected interties                                   | SILVERPK_BG |
|  | <b>Base</b> |
| MIC expansion request MW behind constraint           | 13 MW       |
| Deliverable MIC expansion request MW with mitigation | 0 MW        |

**Lugo–Victor 230 kV Corridor Constraint**

The overloading of the Lugo–Victor #3 and #4 230 kV lines under the contingency conditions indicated in Table F.14-8 affect deliverability of capacity resources in the NOL area. Up to 1086 MW of capacity resources in the base portfolio will be undeliverable without mitigation. Table F.14-9 provides a summary of Lugo–Victor 230 kV line Constraint.

Table F.14-8: Lugo–Victor 230 kV corridor on-peak deliverability constraint

| Overloaded Facility                 | Contingency                         | Base Portfolio Loading (%) |     |
|-------------------------------------|-------------------------------------|----------------------------|-----|
|                                     |                                     | HSN                        | SSN |
| Lugo- Victor #3 and #4 230 kV lines | Lugo- Victor #1 and #2 230 kV lines | 102                        | 124 |

Table F.14-9: On-peak Lugo–Victor 230 kV corridor constraint summary

|                             |                   |
|-----------------------------|-------------------|
| Affected transmission zones | NOL area          |
|                             | <b>Base (SSN)</b> |

|  |                                     |            |
|--|-------------------------------------|------------|
| Portfolio MW behind constraint                 |                                     | 3006 MW    |
| Portfolio battery storage MW behind constraint |                                     | 1229 MW    |
| Deliverable portfolio MW w/o mitigation        |                                     | 2262 MW    |
| Total undeliverable baseline and portfolio MW  |                                     | 1086 MW    |
| Mitigation Options                             | RAS                                 | HDPP RAS   |
|  | Reduce generic battery storage (MW) | Not needed |
|  | Transmission upgrade including cost | Not needed |
| Recommended Mitigation                         |                                     | HDPP RAS   |

Since the existing High Desert Power Project RAS adequately mitigates the deliverability constraint, no further mitigation solution was found to be needed.

The Lugo–Victor 230 kV corridor constraint was found to impact MIC expansion requests as shown in Table F.14-10.

Table F.14-10: MIC expansion requests impacted by the Lugo–Victor 230 kV corridor constraint

|  |             |
|--|-------------|
| Affected interties                                   | SILVERPK_BG |
|  | <b>Base</b> |
| MIC expansion request MW behind constraint           | 13 MW       |
| Deliverable MIC expansion request MW with mitigation | 0 MW        |

### F.14.2 2034 Off-peak results

#### Coolwater–Kramer Corridor Constraint

Wind and solar resources in the Kramer-Coolwater area are subject to curtailment due to loading limitations on 230 and 115 kV facilities in the area under contingency conditions as shown in Table F.14-11. Table F.14-12 provides a summary of the constraints including mitigation alternatives considered. The constraints can be mitigated by Mojave Desert RAS or dispatching portfolio battery storage in charging mode.

Table F.14-11: Coolwater–Kramer 230/115 kV corridor off-peak deliverability constraints

| Overloaded Facility           | Contingency                                    | Base Loading (%) |
|-------------------------------|--|------------------|
| Coolwater–Kramer 115 kV       | Kramer–Coolwater & Kramer–Sandlot 230 kV lines | 182              |
| Coolwater 230/115 kV Tr.      |  | 183              |
| Coolwater-Dunnside 115 kV     |  | 184              |
| Kramer 230/115 kV #1 & #2 Tr. |  | 161              |



|                                 |                                 |     |
|---------------------------------|---------------------------------|-----|
| Tortilla–Kramer 115 kV          |                                 | 159 |
| Kramer–Sandlot #1 230 kV line   | Kramer–Coolwater #2 230 kV line | 140 |
| Kramer–Coolwater #2 230 kV line | Kramer–Sandlot #1 230 kV line   | 133 |

Table F.14-12: Coolwater–Kramer off-peak deliverability constraint summary

|   |  |                        |
|---|--|------------------------|
| Affected renewable transmission zones             |  | Sandlot-Coolwater area |
|   |  | <b>Base Portfolio</b>  |
| Portfolio solar and wind MW behind the constraint |  | 1062 MW                |
| Energy storage portfolio MW behind the constraint |  | 645 MW                 |
| Renewable curtailment without mitigation (MW)     |  | 364 MW                 |
| Mitigation Options:                               | Portfolio ES (in charging mode) (MW) <sup>22</sup> | 0 MW                   |
|   | RAS  | Mojave desert RAS      |
|   | Transmission upgrades                              | Not needed             |
| Recommended Mitigation                            |  | Mojave desert RAS      |

**Lugo–Victor 230 kV Corridor Constraint**

The overloading of the Lugo–Victor #3 and #4 230 kV lines under the contingency conditions indicated in Table F.14-13.

<sup>22</sup> The Portfolio energy storage (in charging mode) amount is the amount needed to mitigate the constraint after baseline battery storage is fully utilized.

Table F.14-14 provides a summary of the constraint including mitigation alternatives considered. The constraints can be mitigated by High Desert Power Plant RAS.

Table F.14-13: Lugo-Victor 230 kV corridor off-peak deliverability constraints

| <b>Overloaded Facility</b>          | <b>Contingency</b>                  | <b>Base Loading (%)</b> |
|-------------------------------------|-------------------------------------|-------------------------|
| Lugo- Victor #3 and #4 230 kV lines | Lugo- Victor #1 and #2 230 kV lines | 119                     |

Table F.14-14: Lugo–Victor 230 kV corridor off-peak deliverability constraint summary

|   |  |                       |
|---|--|-----------------------|
| Affected renewable transmission zones             |  | NOL area              |
|   |  | <b>Base Portfolio</b> |
| Portfolio solar and wind MW behind the constraint |  | 2,406 MW              |
| Energy storage portfolio MW behind the constraint |  | 1,480 MW              |
| Renewable curtailment without mitigation (MW)     |  | 449 MW                |
| Mitigation Options:                               | Portfolio ES (in charging mode) (MW) <sup>23</sup> | 0 MW                  |
|   | RAS  | HDPP RAS              |
|   | Transmission upgrades                              | Not needed            |
| Recommended Mitigation                            |  | HDPP RAS              |

**Lugo–Calcite–Pisgah 230 kV Corridor Constraint**

Resources at Calcite and Pisgah will be subject to curtailment due to loading limitations on the Calcite–Pisgah 230 kV line under contingency conditions as shown in Table F.14-15. Table F.14-16 provides summary of the constraints including mitigation alternatives considered. The constraints can be mitigated by the planned Calcite CRAS or dispatching generic portfolio battery storage in charging mode.

Table F.14-15: Lugo–Calcite–Pisgah 230 kV corridor off-peak deliverability constraint

| Overloaded Facility   | Contingency         | Base Loading (%) |
|-----------------------|---------------------|------------------|
| Calcite–Pisgah 230 kV | Calcite–Lugo 230 kV | 128              |

Table F.14-16: Lugo–Calcite–Pisgah 230 kV corridor off-peak deliverability constraint summary

|   |                                |
|---|--------------------------------|
| Affected renewable transmission zones             | Calcite and Pisgah Substations |
|   | <b>Base Portfolio</b>          |
| Portfolio solar and wind MW behind the constraint | 550 MW                         |

<sup>23</sup> The Portfolio energy storage (in charging mode) amount is the amount needed to mitigate the constraint after baseline battery storage is fully utilized.

|   |  |                      |
|---|--|----------------------|
| Energy storage portfolio MW behind the constraint |  | 200 MW               |
| Renewable curtailment without mitigation (MW)     |  | 86 MW                |
| Mitigation Options                                | Portfolio ES (in charging mode) (MW) <sup>24</sup> | 0 MW                 |
|   | RAS  | Planned Calcite CRAS |
|   | Transmission upgrades                              | Not needed           |
| Recommended Mitigation                            |  | Planned Calcite CRAS |

**F.14.3 2039 On-peak results**

**Coolwater–Kramer Corridor Constraint**

The Coolwater–Kramer corridor deliverability constraint, which is comprised of the constraints included in Table F. 14- 17, affect deliverability of capacity resources in the NOL area due to thermal overloading of the planned 230/115 kV transformer and 115 kV lines in the area under contingency conditions as shown in the table. Up to 151 MW of capacity resources in the base portfolio will be undeliverable without mitigation.

Table F.14-3: On-peak Coolwater–Kramer corridor constraint summary provides the constraint summary for the more limiting constraints.

Table F.14-17: Coolwater–Kramer corridor on-peak deliverability constraint

| Overloaded Facility           | Contingency                              | Loading (%) |             |
|-------------------------------|--|-------------|-------------|
|                               |  | Base        | Sensitivity |
| Coolwater–Kramer 115 kV       | Kramer–Coolwater & Kramer–Sandlot 230 kV | 129         | 123         |
| Coolwater 230/115 kV Tr.      |  | 157         | 153         |
| Tortilla–Coolwater 115 kV     |  | 126         | 115         |
| Kramer 230/115 kV #1 & #2 Tr. |  | 126         | 194         |
| Tortilla–Kramer 115 kV        |  | 110         | 106         |

<sup>24</sup> The Portfolio energy storage (in charging mode) amount is the amount needed to mitigate the constraint after baseline battery storage is fully utilized.

|                        |  |     |     |
|------------------------|--|-----|-----|
| Kramer- Inyokern 115kV | BLM West - Kramer 220kV & Kramer- Inyokern-Randsburg 115kV | N/A | 103 |
|------------------------|--|-----|-----|

Table F.14-18: Coolwater–Kramer corridor on-peak constraint summary

| Affected transmission zones                          |                                     | NOL area          |                   |
|--|-------------------------------------|-------------------|-------------------|
|  |                                     | Base              | Sensitivity       |
| Portfolio resources behind the constraint            |                                     | 916 MW            | 916 MW            |
| Portfolio battery storage behind the constraint      |                                     | 417 MW            | 417 MW            |
| Deliverable portfolio resources w/o mitigation       |                                     | 765 MW            | 765 MW            |
| Total undeliverable baseline and portfolio resources |                                     | 151 MW            | 151 MW            |
| Mitigation Options                                   | RAS                                 | Mojave Desert RAS | Mojave Desert RAS |
|  | Reduce generic battery storage (MW) | N/A               | N/A               |
|  | Transmission upgrade including cost | Not Needed        | Not Needed        |
| Recommended Mitigation                               |                                     | Mojave Desert RAS | Mojave Desert RAS |

Remedial Action Schemes (RAS), reducing generic portfolio battery storage and transmission alternatives were considered to address the constraints. Since the existing Mohave Desert RAS adequately mitigates the deliverability constraints, no other solution was found to be needed.

The constraint was found to impact MIC expansion requests in the area as indicated in Table F.14-19.

Table F.14-19: MIC expansion requests impacted by the Coolwater–Kramer corridor constraint

| Affected interties                         | SILVERPK_BG |             |
|--|-------------|-------------|
|  | Base        | Sensitivity |
| MIC expansion request MW behind constraint | 13 MW       | N/A         |
| Deliverable MIC expansion request MW       | 0 MW        | N/A         |

**Control–Inyokern/Haiwee Tap 115 kV and Control Silver Peak 55 kV Constraint**

Control-Inyokern/ Haiwee Tap 115 kV and Control- Silver Peak 55 kV corridor deliverability constraint described in Table F.14-20 affects deliverability of capacity resources in the NOL area due to single and double circuit outage of Control–Coso–Inyokern 115 kV lines. Up to 452 MW of capacity resources in the sensitivity portfolio will be undeliverable without mitigation.

Table F.14-21 provides a summary of the constraint including affected resources and mitigation solutions.

Table F.14-20: Control–Inyokern/Haiwee Tap 115 kV on-peak deliverability constraint

| Overloaded Facility                | Contingency  | Loading (%) |             |
|------------------------------------|--|-------------|-------------|
|                                    |  | Base        | Sensitivity |
| Control – Silver Peak 55kV PST     | Control–Coso–Haiwee–Inyokern 115 kV line & Control–Haiwee–Inyokern 115 kV line<br>(Loading results are based on DC solution as the AC solution diverged) | 130         | 140         |
| Control–Coso- Inyoern 115 kV       | Base case  | N/A         | 112         |
| Control–Coso–Haiwee–Inyoern 115 kV |  | N/A         | 115         |

Table F.14-21: On-peak Control–Inyokern/Haiwee Tap 115 kV and Control Silver Peak 55 kV constraint summary

| Affected transmission zones                          |                                     | South of Control area |   |
|--|-------------------------------------|-----------------------|---|
|  |                                     | Base                  | Sensitivity   |
| Portfolio resources behind the constraint            |                                     | 55 MW                 | 507 MW  |
| Portfolio battery storage behind the constraint      |                                     | 0 MW                  | 0 MW  |
| Deliverable portfolio resources w/o mitigation       |                                     | 55 MW                 | 55 MW   |
| Total undeliverable baseline and portfolio resources |                                     | 0 MW                  | 452 MW  |
| Mitigation Options                                   | RAS                                 | Bishop RAS            | Bishop RAS  |
|  | Reduce generic battery storage (MW) | N/A                   | N/A   |
|  | Transmission upgrade including cost | Not Needed            | Control-Inyokern-Kramer 220 kV upgrade (~\$2B)                    |
| Recommended Mitigation                               |                                     | Bishop RAS            | Relocate undeliverable portfolio resource from Control substation |

RAS and transmission upgrades were considered to address the constraint. Since the existing Bishop RAS adequately mitigates the deliverability constraint for Base case, no further mitigation solution was found to be needed. Bishop RAS is not adequate for Sensitivity scenario requiring transmission upgrade or relocation of undeliverable portfolio.

The constraint was found to impact MIC expansion requests in the area as indicated in Table F.14-22.

Table F.14-22: MIC expansion requests impacted by the Control–Inyokern/Haiwee Tap and Silver Peak constraint

| Affected interties                         | SILVERPK_BG |             |
|--|-------------|-------------|
|  | Base        | Sensitivity |
| MIC expansion request MW behind constraint | 13 MW       | N/A         |
| Deliverable MIC expansion request MW       | 0 MW        | N/A         |

**Lugo–Calcite 230 kV Constraint**

Resources at Calcite will be subject to curtailment due to loading limitations on the Calcite–Lugo 230 kV line under contingency conditions as shown in Table F.14-23. Table F.14-24 provides summary of the constraints including mitigation alternatives considered. The constraints can be mitigated by the planned upgrades and dispatching generic portfolio battery storage in charging mode or reducing/relocating the undeliverable portfolio resource.

Table F.14-23: Lugo–Calcite 230 kV corridor on-peak deliverability constraint

| Overloaded Facility  | Contingency   | Loading (%) |             |
|----------------------|---|-------------|-------------|
|                      |   | Base        | Sensitivity |
| Lugo- Calcite 230 kV | Base Case   | 101         | 105         |
| Calcite- Lugo 230 kV | BLM West - Kramer 220kV & Kramer-<br>Inyokern-Randsburg 115kV | 102         | 106         |

Table F.14-24: Lugo–Calcite 230 kV corridor on-peak deliverability constraint summary

| Affected transmission zones                          |                                     | Calcite and Lugo Substations               |  |
|--|-------------------------------------|--|--|
|  |                                     | Base                                       | Sensitivity                                |
| Portfolio resources behind the constraint            |                                     | 1145 MW                                    | 1725 MW                                    |
| Portfolio battery storage behind the constraint      |                                     | 315 MW                                     | 295 MW                                     |
| Deliverable portfolio resources w/o mitigation       |                                     | 1115 MW                                    | 1663 MW                                    |
| Total undeliverable baseline and portfolio resources |                                     | 30 MW                                      | 62 MW                                      |
| Mitigation Options                                   | RAS                                 | N/A as it is a P0 contingency              | N/A as it is a P0 contingency              |
|  | Reduce generic battery storage (MW) | 30 MW                                      | 62 MW                                      |
|  | Transmission upgrade including cost | Pisgah substation loop in project (\$218M) | Pisgah substation loop in project (\$218M) |
| Recommended Mitigation                               |                                     | Reduce 30 MW of generic battery storage    | Reduce 62 MW of generic battery storage    |



The constraint was not found to impact MIC expansion requests in the area as indicated in Table F.14-25.

Table F.14-25: MIC expansion requests impacted by the Control–Inyokern/Haiwee Tap and Silver Peak constraint

| Affected interties                         | SILVERPK_BG |             |
|--|-------------|-------------|
|  | Base        | Sensitivity |
| MIC expansion request MW behind constraint | 13 MW       | N/A         |
| Deliverable MIC expansion request MW       | 13 MW       | N/A         |

**F.14.4 Conclusion and recommendation**

The following conclusion can be made based on the North of Lugo Area deliverability assessment:

- All portfolio resources in the NOL area are deliverable with existing or expanded Remedial Action Schemes (RAS) except for the 2039 Base and Sensitivity portfolio due to Lugo- Calcite overload (P0). Off-peak deliverability constraints can be addressed using RAS or dispatching portfolio battery storage in charging mode;
- Out of the 13 MW of California Community Power’s SILVERPK\_BG MIC expansion request, 0 MW is deliverable as the MIC expansion request contributes to constraints in the North of Lugo area.

**F.15 SCE Metro Area**

The total capacity of resources, by resource type, selected with Full Capacity Deliverability Status (FCDS) as well as those selected as Energy Only (EO) in the SCE Metro interconnection area, are listed in Table F.15-1. The portfolios in the interconnection area are comprised of battery storage and biomass/biogas resources. All portfolio resources are modeled in policy-driven assessments except in the on-peak deliverability assessment in which only FCDS resources are modeled.

Table F.15-1: SCE Metro Interconnection Area – Base and Sensitivity Portfolios by Resource Types (FCDS, EO and Total)

| Resource Type                       | 2034 Base Portfolio |          |              | 2039 Base Portfolio |          |              | 2039 Sensitivity Portfolio |          |              |
|-------------------------------------|---------------------|----------|--------------|---------------------|----------|--------------|----------------------------|----------|--------------|
|                                     | FCDS (MW)           | EO (MW)  | Total (MW)   | FCDS (MW)           | EO (MW)  | Total (MW)   | FCDS (MW)                  | EO (MW)  | Total (MW)   |
| Solar                               | 0                   | 0        | 0            | 0                   | 0        | 0            | 0                          | 0        | 0            |
| Wind – In State                     | 0                   | 0        | 0            | 0                   | 0        | 0            | 0                          | 0        | 0            |
| Wind – Out-of-State                 | 0                   | 0        | 0            | 0                   | 0        | 0            | 0                          | 0        | 0            |
| Wind - Offshore                     | 0                   | 0        | 0            | 0                   | 0        | 0            | 0                          | 0        | 0            |
| Li Battery – 4 hr                   | 1,879               | 0        | 1,879        | 1,929               | 0        | 1,929        | 979                        | 0        | 979          |
| Li Battery – 8 hr                   | 167                 | 0        | 167          | 447                 | 0        | 447          | 1,292                      | 0        | 1,292        |
| Long Duration Energy Storage (LDES) | 0                   | 0        | 0            | 0                   | 0        | 0            | 0                          | 0        | 0            |
| Geothermal                          | 0                   | 0        | 0            | 0                   | 0        | 0            | 0                          | 0        | 0            |
| Biomass/Biogas                      | 6                   | 0        | 6            | 6                   | 0        | 6            | 6                          | 0        | 6            |
| Distributed Solar                   | 27                  | 0        | 27           | 34                  | 0        | 34           | 40                         | 0        | 40           |
| <b>Total</b>                        | <b>2,078</b>        | <b>0</b> | <b>2,078</b> | <b>2,415</b>        | <b>0</b> | <b>2,415</b> | <b>2,316</b>               | <b>0</b> | <b>2,316</b> |

Figure F.15-1: SCE Metro Interconnection Area – 2034 Base Portfolio

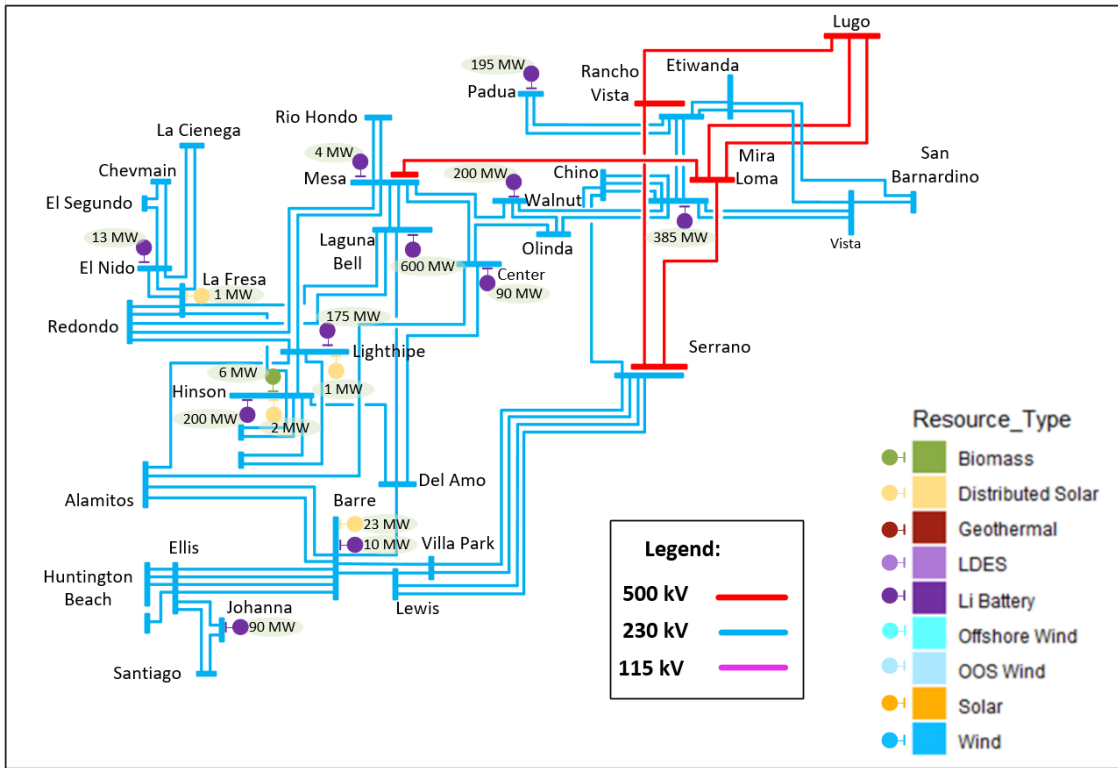
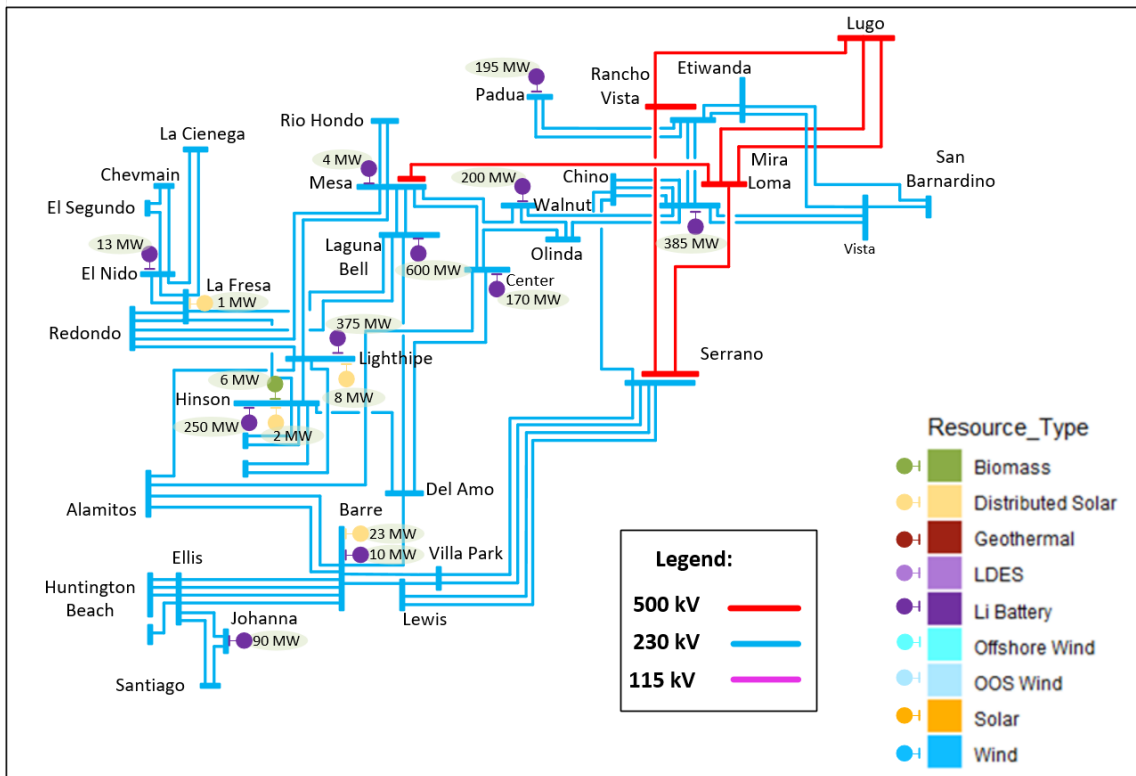

Figure F.15-2: SCE Metro Interconnection Area – 2039 Base Portfolio



**F.15.1 2034 On-peak results**

The SCE Metro area deliverability assessment did not identify any base portfolio 2034 on-peak deliverability constraints that require transmission upgrades.

**F.15.2 2034 Off-peak results**

The SCE Metro area deliverability assessment did not identify any base portfolio off-peak deliverability constraints that require transmission upgrades.

**F.15.3 2039 On-peak results**

The SCE Metro area deliverability assessment did not identify any base portfolio 2039 on-peak deliverability constraints that require transmission upgrades.

**F.15.4 Conclusion and recommendation**

The SCE Metro area deliverability assessment did not identify any base portfolio (on-peak or off-peak) deliverability constraints that require transmission upgrades.

## F.16 SCE Eastern

The total capacity of resources, by resource type, selected with Full Capacity Deliverability Status (FCDS) as well as those selected as Energy Only (EO) in the SCE Eastern interconnection area are listed in Table F.16-1. The portfolios are comprised of solar, wind (in-state and out-of-state), battery storage and biomass/biogas resources. All portfolio resources are modeled in policy-driven assessments except in the on-peak deliverability assessment in which only FCDS resources are modeled.

Table F.16-1: SCE Eastern Interconnection Area – Base and Sensitivity Portfolio by Resource Types (FCDS, EO and Total)

| Resource Type                       | 2034 Base Portfolio |              |               | 2039 Base Portfolio |              |               | 2039 Sensitivity Portfolio |              |               |
|-------------------------------------|---------------------|--------------|---------------|---------------------|--------------|---------------|----------------------------|--------------|---------------|
|                                     | FCDS (MW)           | EO (MW)      | Total (MW)    | FCDS (MW)           | EO (MW)      | Total (MW)    | FCDS (MW)                  | EO (MW)      | Total (MW)    |
| Solar                               | 810                 | 2,649        | 3,459         | 1,610               | 4,224        | 5,834         | 3,410                      | 5,674        | 8,784         |
| Wind – In State                     | 224                 | 100          | 324           | 224                 | 100          | 324           | 224                        | 100          | 324           |
| Wind – Out-of-State                 | 2,131               | 0            | 2,131         | 3,536               | 0            | 3,536         | 3,006                      | 0            | 3,006         |
| Wind - Offshore                     | 0                   | 0            | 0             | 0                   | 0            | 0             | 0                          | 0            | 0             |
| Li Battery – 4 hr                   | 3,770               | 468          | 4,238         | 3,270               | 468          | 3,738         | 3,179                      | 468          | 3,647         |
| Li Battery – 8 hr                   | 270                 | 0            | 270           | 1,070               | 0            | 1,070         | 1,875                      | 0            | 1,875         |
| Long Duration Energy Storage (LDES) | 0                   | 0            | 0             | 0                   | 0            | 0             | 1,190                      | 0            | 1,190         |
| Geothermal                          | 790                 | 0            | 790           | 790                 | 0            | 790           | 1,380                      | 0            | 1,380         |
| Biomass/Biogas                      | 3                   | 0            | 3             | 3                   | 0            | 3             | 3                          | 0            | 3             |
| Distributed Solar                   | 0                   | 0            | 0             | 0                   | 0            | 0             | 0                          | 0            | 0             |
| <b>Total</b>                        | <b>7,997</b>        | <b>3,217</b> | <b>11,214</b> | <b>10,502</b>       | <b>4,792</b> | <b>15,294</b> | <b>14,266</b>              | <b>6,242</b> | <b>20,508</b> |

The resources as identified in the CPUC busbar mapping for the SCE Eastern interconnection area are illustrated on the single-line diagram in Figure F.16-1 and Figure F.16-2.

Figure F.16-1: SCE Eastern Interconnection Area – Mapped 2034 Base Portfolio

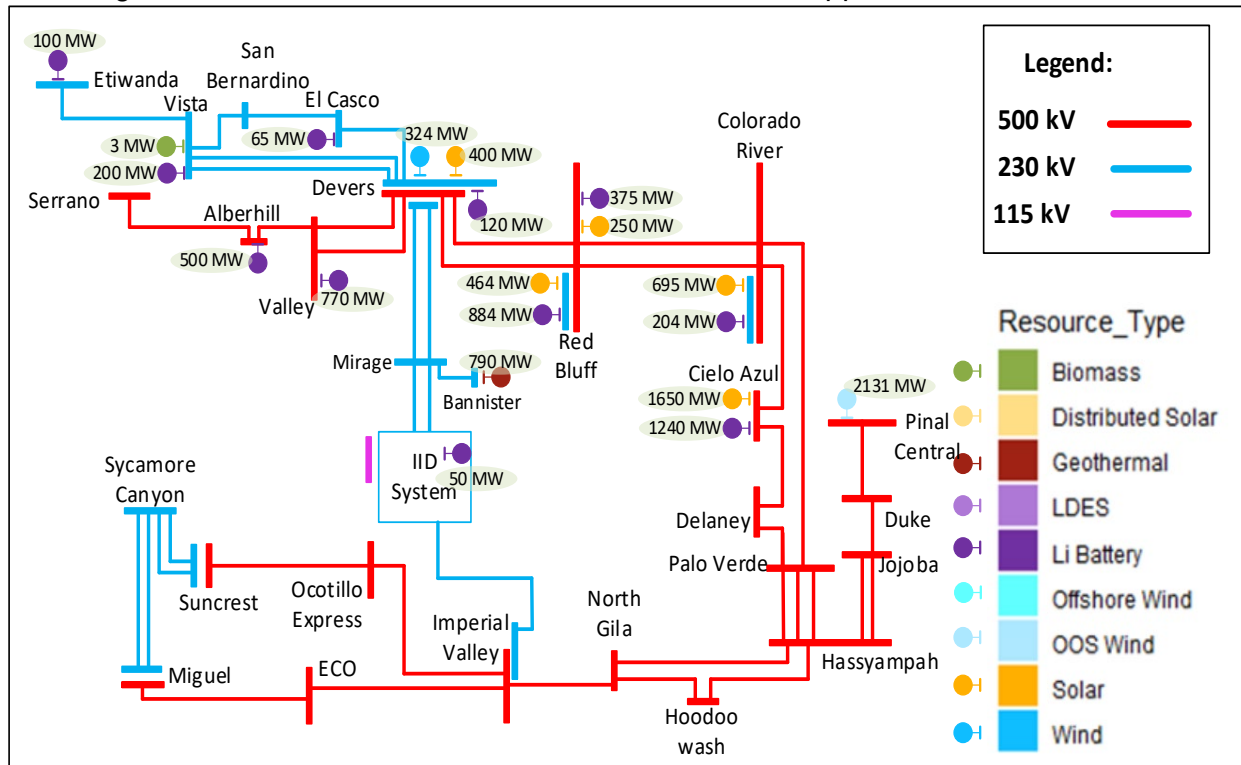
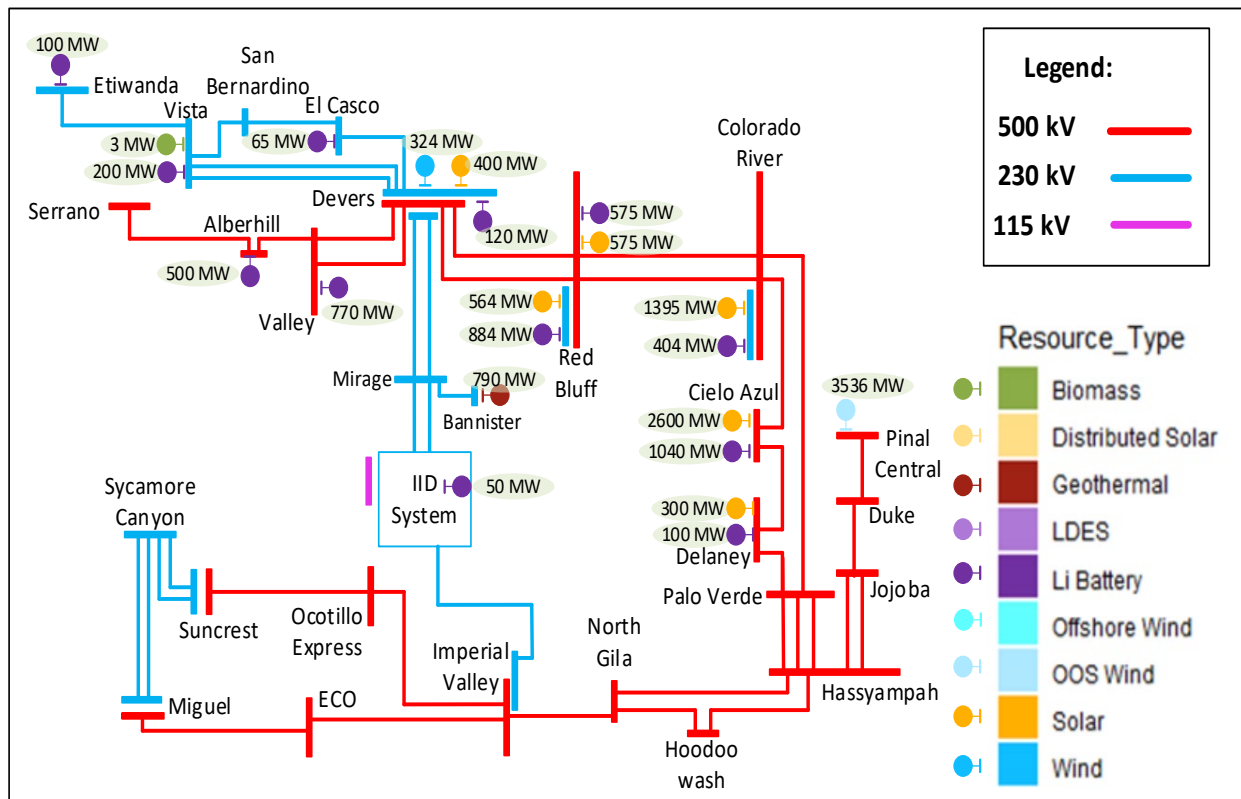

Figure F.16-2: SCE Eastern Interconnection Area – Mapped 2039 Base Portfolio



**F.16.1 2034 On-peak results**

**Colorado River 500/230 kV constraint**

The deliverability of FC resources interconnecting at the Colorado River 230 kV bus is limited by thermal overloading of the 500/230 kV transformers under Category P1 conditions as shown in Table F.16-2. The constraint was observed under both the HSN and SSN scenarios. Table F.16-3 shows the amount of generation that would be undeliverable without mitigation. The constraint can be mitigated by the existing West of Colorado River CRAS.

Table F.16-2: Colorado River 500/230 kV deliverability constraint

| Overloaded Facility                        | Contingency                                | Loading (%) |     |
|--|--|-------------|-----|
|  |  | HSN         | SSN |
| Colorado River 500/230 kV Transformer No.1 | Colorado River 500/230 kV Transformer No.2 | 121         | 121 |
| Colorado River 500/230 kV Transformer No.2 | Colorado River 500/230 kV Transformer No.1 | 121         | 121 |

Table F.16-3: Colorado River 500/230 kV deliverability constraint summary

|  |                                     |                                      |
|--|-------------------------------------|--------------------------------------|
| Affected transmission zones  |                                     | Colorado River 230 kV                |
| Portfolio resources behind the constraint (Installed FCDS capacity)            |                                     | 455 MW                               |
| Portfolio battery storage behind the constraint (Installed FCDS capacity)      |                                     | 160 MW                               |
| Deliverable portfolio resources w/o mitigation (Installed FCDS capacity)       |                                     | 0 MW                                 |
| Total undeliverable baseline and portfolio resources (Installed FCDS capacity) |                                     | 556 MW                               |
| Mitigation Options   | RAS                                 | Existing West of Colorado River CRAS |
|  | Reduce generic battery storage (MW) | Not needed                           |
|  | Transmission upgrade including cost | Not needed                           |
| Recommended Mitigation   |                                     | Existing West of Colorado River CRAS |

|  |     |
|--|-----|
| Affected interties                         | N/A |
| MIC expansion request MW behind constraint | N/A |
| Deliverable MIC expansion request MW       | N/A |

**F.16.2 2034 Off-peak results**

**Colorado River 500/230 kV off-peak deliverability constraint**

Wind and solar resources interconnecting at the Colorado River 230 kV bus are subject to curtailment in the base portfolio due to loading limitations on the transformers under Category P1 conditions, as shown in Table F.16-4. Pre-contingency curtailment can be avoided by dispatching battery storage in charging mode and/or utilizing the existing West of Colorado River CRAS.

Table F.16-4: Colorado River 500/230 kV off-peak deliverability constraint

| Overloaded Facility                        | Contingency                                | Loading (%) |
|--|--|-------------|
| Colorado River 500/230 kV Transformer No.1 | Colorado River 500/230 kV Transformer No.2 | 131         |
| Colorado River 500/230 kV Transformer No.2 | Colorado River 500/230 kV Transformer No.1 | 131         |

Table F.16-5: Colorado River 500/230 kV off-peak deliverability constraint summary

|  |   |   |
|--|---|---|
| Affected renewable transmission zones                    |   | Colorado River 230 kV   |
| Portfolio solar and wind resources behind the constraint |   | 651 MW  |
| Portfolio energy storage behind the constraint           |   | 160 MW  |
| Renewable curtailment without mitigation                 |   | 615 MW  |
| Mitigation Options:                                      | Portfolio ES (in charging mode) <sup>25</sup> | 0 MW  |
|  | RAS   | Existing West of Colorado River CRAS  |
|  | Transmission upgrades                         | Not needed  |
| Recommended Mitigation                                   |   | Existing West of Colorado River CRAS and/or baseline battery storage in charging mode |

**Red Bluff 500/230 kV off-peak deliverability constraint**

Wind and solar resources interconnecting at the Red Bluff 230 kV bus are subject to curtailment in the base portfolio due to loading limitations on the transformers under Category P1 conditions, as shown in Table F.16-6. Pre-contingency curtailment can be avoided by

<sup>25</sup> The Portfolio energy storage (in charging mode) amount is the amount needed to mitigate the constraint after baseline battery storage is fully utilized.



dispatching battery storage in charging mode and/or utilizing the existing West of Colorado River CRAS.

Table F.16-6: Red Bluff 500/230 kV off-peak deliverability constraint

| Overloaded Facility                   | Contingency                           | Loading (%) |
|---------------------------------------|---------------------------------------|-------------|
| Red Bluff 500/230 kV Transformer No.1 | Red Bluff 500/230 kV Transformer No.2 | 118         |
| Red Bluff 500/230 kV Transformer No.2 | Red Bluff 500/230 kV Transformer No.1 | 118         |

Table F.16-7: Red Bluff 500/230 kV off-peak deliverability constraint summary

|  |   |   |
|--|---|---|
| Affected renewable transmission zones                    |   | Red Bluff 230 kV  |
| Portfolio solar and wind resources behind the constraint |   | 471 MW  |
| Portfolio energy storage behind the constraint           |   | 924 MW  |
| Renewable curtailment without mitigation                 |   | 370 MW  |
| Mitigation Options:                                      | Portfolio ES (in charging mode) <sup>26</sup> | 0 MW  |
|  | RAS   | Existing West of Colorado River CRAS  |
|  | Transmission upgrades                         | Not needed  |
| Recommended Mitigation                                   |   | Existing West of Colorado River CRAS and/or baseline battery storage in charging mode |

<sup>26</sup> The Portfolio energy storage (in charging mode) amount is the amount needed to mitigate the constraint after baseline battery storage is fully utilized.

### F.16.3 2039 On-peak results

#### Colorado River 500/230 kV constraint

The deliverability of FC resources interconnecting at the Colorado River 230 kV bus is limited by thermal overloading of the 500/230 kV transformers under Category P1 conditions as shown in Table F.16-8. The constraint was observed in both the base and sensitivity portfolios. Table F.16-9 shows the amount of generation that would be undeliverable without mitigation.

For the base portfolio, the constraint can be mitigated by the existing West of Colorado River CRAS. However, the CRAS alone is not sufficient for the sensitivity portfolio since the amount of generation tripping needed exceeds the 1150 MW limit for a P1 contingency. Reducing generic battery storage is also not considered to be a viable solution. To fully mitigate the constraint in the sensitivity portfolio, transmission upgrades are required. The transmission upgrade considered is to install another 500/230 kV transformer at Colorado River.

Table F.16-8: Colorado River 500/230 kV deliverability constraint

| Overloaded Facility                        | Contingency                                | Loading (%) |             |
|--|--|-------------|-------------|
|  |  | Base        | Sensitivity |
| Colorado River 500/230 kV Transformer No.1 | Colorado River 500/230 kV Transformer No.2 | 138         | 154         |
| Colorado River 500/230 kV Transformer No.2 | Colorado River 500/230 kV Transformer No.1 | 138         | 154         |

Table F.16-9: Colorado River 500/230 kV deliverability constraint summary

| Affected transmission zones  |     | Colorado River 230 kV                |   |
|--|-----|--------------------------------------|---|
|  |     | Base                                 | Sensitivity   |
| Portfolio resources behind the constraint (Installed FCDS capacity)            |     | 857 MW                               | 1500 MW   |
| Portfolio battery storage behind the constraint (Installed FCDS capacity)      |     | 360 MW                               | 500 MW  |
| Deliverable portfolio resources w/o mitigation (Installed FCDS capacity)       |     | 0 MW                                 | 0 MW  |
| Total undeliverable baseline and portfolio resources (Installed FCDS capacity) |     | 958 MW                               | 1609 MW   |
| Mitigation Options   | RAS | Existing West of Colorado River CRAS | Existing West of Colorado River CRAS alone not sufficient |

|                        |                                     |                                      |  |
|------------------------|-------------------------------------|--------------------------------------|--|
|                        | Reduce generic battery storage (MW) | Not needed                           | Not sufficient   |
|                        | Transmission upgrade including cost | Not needed                           | New Colorado River No.3 500/230 kV transformer (\$67M) |
| Recommended Mitigation |                                     | Existing West of Colorado River CRAS | Transmission upgrades only needed for sensitivity case |

|  |      |             |
|--|------|-------------|
| Affected interties                         | N/A  |             |
|  | Base | Sensitivity |
| MIC expansion request MW behind constraint | N/A  | N/A         |
| Deliverable MIC expansion request MW       | N/A  | N/A         |

**Devers-Red Bluff constraint**

The deliverability of FC resources in the SCE Eastern and SDG&E areas is limited by thermal overloading of the Devers-Red Bluff 500 kV lines under Category P1 conditions as shown in Table F.16-10. The constraint was observed in both the base and sensitivity portfolios. Table F.16-11 shows the amount of generation that would be undeliverable without mitigation.

For the base portfolio, the constraint can be mitigated by the existing West of Colorado River CRAS. However, the CRAS alone is not sufficient for the sensitivity portfolio since the amount of generation tripping needed exceeds the 1150 MW limit for a P1 contingency. Reducing generic battery storage is also not considered to be a viable solution. To fully mitigate the constraint in the sensitivity portfolio, transmission upgrades are required. The transmission upgrade package considered is to build another Devers-Red Bluff 500 kV transmission line along with a new Devers-Mira Loma 500 kV transmission line.

Table F.16-10: Devers-Red Bluff deliverability constraint

| Overloaded Facility            | Contingency                    | Loading (%) |             |
|--------------------------------|--------------------------------|-------------|-------------|
|                                |                                | Base        | Sensitivity |
| Devers – Red Bluff 500 kV No.1 | Devers – Red Bluff 500 kV No.2 | 101         | 118         |
| Devers – Red Bluff 500 kV No.2 | Devers – Red Bluff 500 kV No.1 | 101         | 118         |

Table F.16-11: Devers-Red Bluff deliverability constraint summary

| Affected transmission zones  |                                     | SCE Eastern (east of Red Bluff) and SDG&E |   |
|--|-------------------------------------|---|---|
|  |                                     | Base                                      | Sensitivity   |
| Portfolio resources behind the constraint (Installed FCDS capacity)            |                                     | 8038 MW                                   | 10419 MW  |
| Portfolio battery storage behind the constraint (Installed FCDS capacity)      |                                     | 2456 MW                                   | 2969 MW   |
| Deliverable portfolio resources w/o mitigation (Installed FCDS capacity)       |                                     | 7860 MW                                   | 8591 MW   |
| Total undeliverable baseline and portfolio resources (Installed FCDS capacity) |                                     | 178 MW                                    | 1828 MW   |
| Mitigation Options   | RAS                                 | Existing West of Colorado River CRAS      | Existing West of Colorado River CRAS alone not sufficient   |
|  | Reduce generic battery storage (MW) | Not needed                                | Not sufficient  |
|  | Transmission upgrade including cost | Not needed                                | New Devers-Red Bluff 500 kV transmission line (\$875M) and New Devers-Mira Loma 500 kV transmission line (\$1.1B) |
| Recommended Mitigation   |                                     | Existing West of Colorado River CRAS      | Transmission upgrades only needed for sensitivity case  |

| Affected interties                         | N/A  |             |
|--|------|-------------|
|  | Base | Sensitivity |
| MIC expansion request MW behind constraint | N/A  | N/A         |
| Deliverable MIC expansion request MW       | N/A  | N/A         |

**WECC Path 42 constraint**

The deliverability of FC resources in the IID area is limited by thermal overloading of 230 kV lines related to WECC Path 42 as shown in Table F.16-12. The constraint was only observed in the sensitivity portfolio. Table F.16-13 shows the amount of generation that would be undeliverable without mitigation. The constraint can be mitigated by the Path 42 RAS.

Table F.16-12: WECC Path 42 deliverability constraint

| Overloaded Facility                   | Contingency                           | Loading (%) |             |
|---------------------------------------|---------------------------------------|-------------|-------------|
|                                       |                                       | Base        | Sensitivity |
| Coachella Valley – Ramon 230 kV No.1  | Coachella Valley – Mirage 230 kV No.1 | <100        | 113         |
| Ramon – Mirage 230 kV No.1            |                                       | <100        | 103         |
| Coachella Valley – Mirage 230 kV No.1 | Coachella Valley – Ramon 230 kV No.1  | <100        | 108         |

Table F.16-13: WECC Path 42 deliverability constraint summary

| Affected transmission zones  |                                     | IID  |                       |
|--|-------------------------------------|--|-----------------------|
|  |                                     | Base   | Sensitivity           |
| Portfolio resources behind the constraint (Installed FCDS capacity)            |                                     | N/A  | 1608 MW               |
| Portfolio battery storage behind the constraint (Installed FCDS capacity)      |                                     |  | 0 MW                  |
| Deliverable portfolio resources w/o mitigation (Installed FCDS capacity)       |                                     |  | 1355 MW               |
| Total undeliverable baseline and portfolio resources (Installed FCDS capacity) |                                     |  | 253 MW                |
| Mitigation Options   | RAS                                 |  | Path 42 RAS expansion |
|  | Reduce generic battery storage (MW) |  | Not needed            |
|  | Transmission upgrade including cost |  | Not needed            |
| Recommended Mitigation   |                                     | Path 42 RAS expansion only needed for sensitivity case |                       |

| Affected interties                         | N/A  |             |
|--|------|-------------|
|  | Base | Sensitivity |
| MIC expansion request MW behind constraint | N/A  | N/A         |
| Deliverable MIC expansion request MW       | N/A  | N/A         |

**Serrano-Alberhill-Valley constraint**

The deliverability of FC resources in the SCE Eastern, SDG&E, and IID areas is limited by thermal overloading of lines and transformers as shown in Table F.16-14. The constraint was only observed in the sensitivity portfolio. Table F.16-15 shows the amount of generation that would be undeliverable without mitigation.

RAS is not allowed to address a base case overload, therefore, it is not a valid solution for the Serrano-Alberhill-Valley constraint. Reducing generic battery storage is also not considered to be a viable solution. To fully mitigate the constraint in the sensitivity portfolio, transmission upgrades are required. The transmission upgrade package considered is to build another Devers-Red Bluff 500 kV transmission line along with a new Devers-Mira Loma 500 kV transmission line.

Table F.16-14: Serrano-Alberhill-Valley deliverability constraint

| Overloaded Facility                  | Contingency                          | Loading (%) |             |
|--------------------------------------|--------------------------------------|-------------|-------------|
|                                      |                                      | Base        | Sensitivity |
| Devers 500/230 kV Transformer No. 1  | Serrano-Alberhill-Valley 500 kV No.1 | <100        | 108         |
| Serrano-Alberhill-Valley 500 kV No.1 | Base Case                            | <100        | 102         |

Table F.16-15: Serrano-Alberhill-Valley deliverability constraint summary

| Affected transmission zones  |                                     | SCE Eastern, SDG&E, IID |  |
|--|-------------------------------------|-------------------------|--|
|  |                                     | Base                    | Sensitivity  |
| Portfolio resources behind the constraint (Installed FCDS capacity)            |                                     | N/A                     | 11725 MW   |
| Portfolio battery storage behind the constraint (Installed FCDS capacity)      |                                     |                         | 3775 MW  |
| Deliverable portfolio resources w/o mitigation (Installed FCDS capacity)       |                                     |                         | 11250 MW   |
| Total undeliverable baseline and portfolio resources (Installed FCDS capacity) |                                     |                         | 475 MW   |
| Mitigation Options   | RAS                                 |                         | RAS not allowed to address Base Case overload              |
|  | Reduce generic battery storage (MW) |                         | Not sufficient   |
|  | Transmission upgrade including cost |                         | New Devers-Mira Loma 500 kV transmission line (\$1.1B) and |

|                        |  |  |
|------------------------|--|--|
|                        |  | New Devers-Red Bluff 500 kV transmission line (\$875M) |
| Recommended Mitigation |  | Transmission upgrades only needed for sensitivity case |

|  |      |             |
|--|------|-------------|
| Affected interties                         | N/A  |             |
|  | Base | Sensitivity |
| MIC expansion request MW behind constraint | N/A  | N/A         |
| Deliverable MIC expansion request MW       | N/A  | N/A         |

**F.16.4 Conclusion and recommendation**

The SCE Eastern area base and sensitivity portfolios deliverability assessment identified on-peak and off-peak deliverability constraints. RAS can be used to mitigate several of these constraints. The off-peak deliverability constraints can also be mitigated by dispatching battery storage in charging mode. And while transmission upgrades were considered, none of those upgrades are being recommended for approval in this planning cycle given that they are only needed for the 2039 sensitivity portfolio.

**Vista-Etiwanda 230 kV 1 Line Upgrade scope change**

The ISO approved the Vista-Etiwanda 230 kV 1 Line Upgrade project in the 2022-2023 Transmission Plan to increase the rating of the Vista-Etiwanda No. 1 230 kV line from 797 / 876 MVA (normal/emergency) to 988 / 1331 MVA (normal/emergency). The scope of this project requires ground clearance violations on the line to be mitigated, and by doing so, it allows the line to achieve the full conductor rating.

SCE has begun the execution of this project and recommends the following scope modification:

- The Etiwanda-Vista 230 kV line and Etiwanda-San Bernardino 230 kV line share double circuit structures along a 10-mile corridor. The Etiwanda – San Bernardino 230 kV line is to be reconductored with HTLS as part of a separate project approved in the 2022-2023 Transmission Plan. Complexities in execution arise with two separate projects on the same tower/structure. Thus, SCE recommends modifying the original scope from mitigating ground clearance with structure raises to, mitigating ground clearance by reconductoring 10 miles of the Etiwanda- Vista 230 kV line with HTLS (along the double circuit corridor) and raising four structures resulting in the requested 988/1331 MVA (normal/emergency) rating. The estimated cost is \$19 million.

The ISO concurs with the scope modifications recommended by SCE.

## F.17 SDG&E area

The total capacity of resources, by resource type, selected with Full Capacity Deliverability Status (FCDS) as well as those selected as Energy Only (EO) in the SDG&E interconnection area are listed in Table F.17-1. The portfolios in the interconnection area are comprised of solar, wind (instate), battery storage, geothermal, and long duration energy storage resources. All portfolio resources are modeled in policy-driven assessments except in the on-peak deliverability assessment in which only FCDS resources are modeled.

Table F.17-1: SDG&E Interconnection Area – Base and Sensitivity Portfolio by Resource Types (FCDS, EO and Total)

| Resource Type                       | 2034 Base Portfolio |              |              | 2039 Base Portfolio |              |              | 2039 Sensitivity Portfolio |              |              |
|-------------------------------------|---------------------|--------------|--------------|---------------------|--------------|--------------|----------------------------|--------------|--------------|
|                                     | FCDS (MW)           | EO (MW)      | Total (MW)   | FCDS (MW)           | EO (MW)      | Total (MW)   | FCDS (MW)                  | EO (MW)      | Total (MW)   |
| Solar                               | 700                 | 882          | 1,582        | 700                 | 1,219        | 1,919        | 1,950                      | 2,544        | 4,494        |
| Wind – In State                     | 1,325               | 239          | 1,564        | 1,325               | 239          | 1,564        | 1,295                      | 289          | 1,584        |
| Wind – Out-of-State                 | 0                   | 0            | 0            | 0                   | 0            | 0            | 0                          | 0            | 0            |
| Wind - Offshore                     | 0                   | 0            | 0            | 0                   | 0            | 0            | 0                          | 0            | 0            |
| Li Battery – 4 hr                   | 1,390               | 0            | 1,390        | 1,390               | 0            | 1,390        | 1,100                      | 0            | 1,100        |
| Li Battery – 8 hr                   | 100                 | 0            | 100          | 305                 | 0            | 305          | 985                        | 0            | 985          |
| Long Duration Energy Storage (LDES) | 437                 | 0            | 437          | 487                 | 0            | 487          | 500                        | 0            | 500          |
| Geothermal                          | 160                 | 0            | 160          | 160                 | 0            | 160          | 866                        | 0            | 866          |
| Biomass/Biogas                      | 0                   | 0            | 0            | 0                   | 0            | 0            | 0                          | 0            | 0            |
| Distributed Solar                   | 1                   | 0            | 1            | 1                   | 0            | 1            | 1                          | 0            | 1            |
| <b>Total</b>                        | <b>4,113</b>        | <b>1,121</b> | <b>5,234</b> | <b>4,368</b>        | <b>1,458</b> | <b>5,826</b> | <b>6,697</b>               | <b>2,833</b> | <b>9,530</b> |

The resources as identified in the CPUC busbar mapping for the SDG&E interconnection area are illustrated on the single-line diagram in Figure F.17-1 and Figure F.17-2.



Figure F.17-1: SDG&E Interconnection Area – Mapped 2034 Base Portfolio

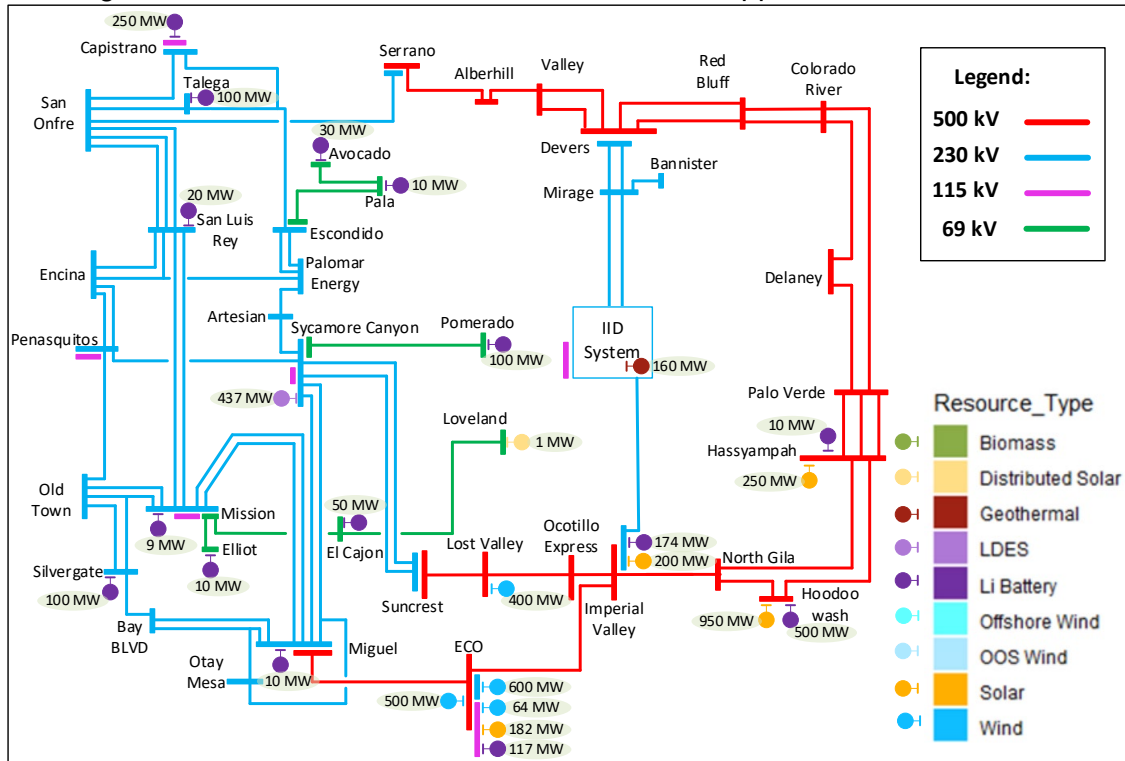
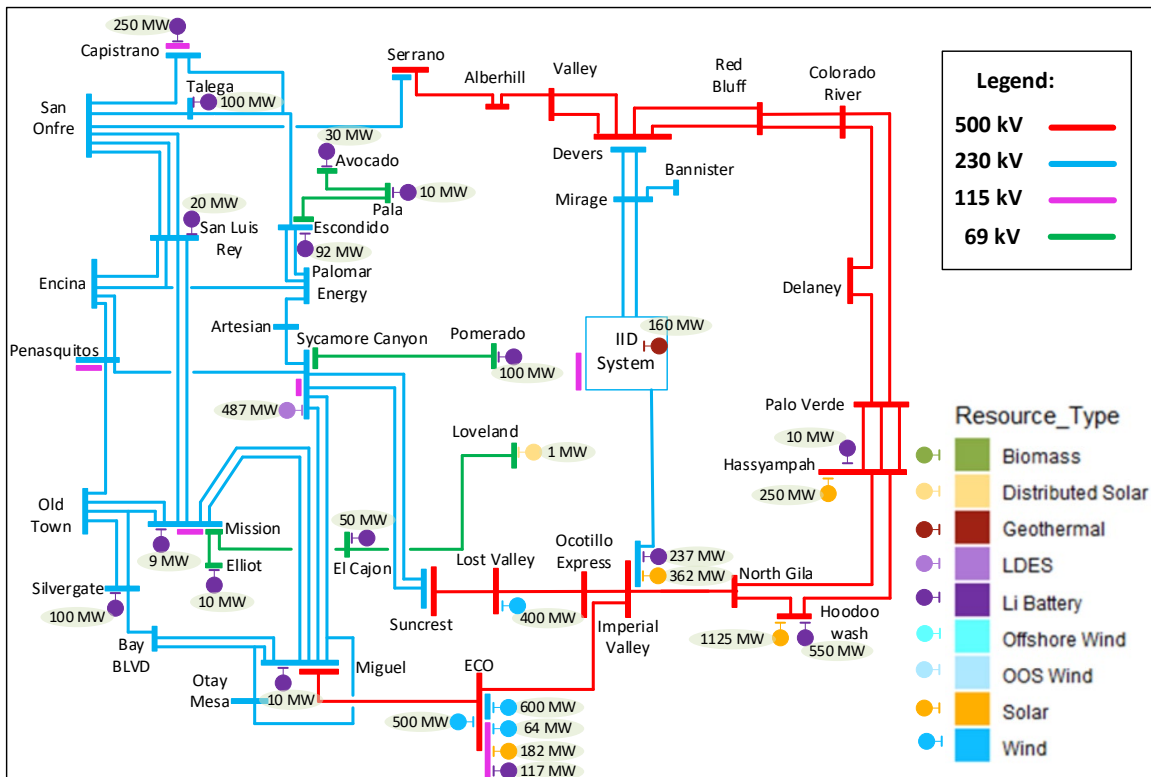

Figure F.17-2: SDG&E Interconnection Area – Mapped 2039 Base Portfolio



**F.17.1 2034 On-peak results**

**Bay Boulevard-Silvergate constraint**

The deliverability of portfolio resources in the Bay Boulevard-Silvergate area is limited by thermal overloading of the Bay Boulevard-Silvergate 230 kV line as shown in Table F.17-2. The constraint was seen in both the HSN and SSN scenarios, with the higher loadings being in the HSN scenario. Table F.17-3 shows the amount of portfolio generation that would be deliverable without any transmission upgrades.

The constraint can be mitigated by using the 2-hour emergency rating of the Bay Boulevard-Silvergate 230 kV line.

Table F.17-2: Bay Boulevard-Silvergate deliverability constraint

| Overloaded Facility             | Contingency                     | Highest Loading (%) |      |
|---------------------------------|---------------------------------|---------------------|------|
|                                 |                                 | HSN                 | SSN  |
| Bay Boulevard-Silvergate 230 kV | Imperial Valley-NSONGS 500 kV   | 106                 | 100  |
| Bay Boulevard-Silvergate 230 kV | Miguel-Mission 230 kV #1 and #2 | 108                 | <100 |

Table F.17-3: Bay Boulevard-Silvergate deliverability constraint summary

|  |                                     |   |
|--|-------------------------------------|---|
| Affected transmission zones  |                                     | Imperial Valley, ECO/BUE, SDGE Internal |
| Portfolio resources behind the constraint (Installed FCDS capacity)            |                                     | 746                                     |
| Portfolio battery storage behind the constraint (Installed FCDS capacity)      |                                     | 121                                     |
| Deliverable portfolio resources w/o mitigation (Installed FCDS capacity)       |                                     | 0                                       |
| Total undeliverable baseline and portfolio resources (Installed FCDS capacity) |                                     | 971                                     |
| Mitigation Options   | RAS                                 | None                                    |
|  | Reduce generic battery storage (MW) | None                                    |
|  | Transmission upgrade including cost | Not needed                              |
| Recommended Mitigation   |                                     | Use 2 hour emergency rating             |

|  |                                     |
|--|-------------------------------------|
| Affected interties                         | IID-SDGE_ITC                        |
| MIC expansion request MW behind constraint | 35                                  |
| Deliverable MIC expansion request MW       | 35<br>(Use 2 hour emergency rating) |

**Silvergate-Old Town constraint**

The deliverability of portfolio resources in the Silvergate-Old Town area is limited by thermal overloading of the Silvergate-Old Town 230 kV lines as shown in Table F.17-4. The constraint was seen in both the HSN and SSN scenarios, with the higher loadings being in the HSN scenario.

Table F.17-5: Silvergate-Old Town deliverability constraint summary shows the amount of portfolio generation that would be deliverable without any transmission upgrades.

The constraint can be mitigated by using the 30 minute rating of the overloaded lines.

Table F.17-4: Silvergate-Old Town deliverability constraint

| Overloaded Facility            | Contingency  | Highest Loading (%) |      |
|--------------------------------|--|---------------------|------|
|                                |  | HSN                 | SSN  |
| Silvergate-Old Town 230 kV     | Silvergate-Mission-Old Town 230 kV                             | 108                 | 103  |
| Silvergate-Old Town Tap 230 kV | Silvergate-Old Town 230 kV                                     | 107                 | 104  |
| Silvergate-Old Town Tap 230 kV | Silvergate-Mission-Old Town 230 kV and Old Town-Mission 230 kV | 103                 | <100 |

Table F.17-5: Silvergate-Old Town deliverability constraint summary

|  |                                     |   |
|--|-------------------------------------|---|
| Affected transmission zones  |                                     | Imperial Valley, ECO/BUE, SDGE Internal |
| Portfolio resources behind the constraint (Installed FCDS capacity)            |                                     | 501                                     |
| Portfolio battery storage behind the constraint (Installed FCDS capacity)      |                                     | 184                                     |
| Deliverable portfolio resources w/o mitigation (Installed FCDS capacity)       |                                     | 136                                     |
| Total undeliverable baseline and portfolio resources (Installed FCDS capacity) |                                     | 365                                     |
| Mitigation Options   | RAS                                 | None                                    |
|  | Reduce generic battery storage (MW) | None                                    |
|  | Transmission upgrade including cost | Not needed                              |
| Recommended Mitigation   |                                     | Use 30 minute emergency rating          |

|  |              |
|--|--------------|
| Affected interties                         | IID-SDGE_ITC |
| MIC expansion request MW behind constraint | 35           |

|                                      |  |
|--------------------------------------|--|
| Deliverable MIC expansion request MW | 35<br>(Use 30 minute emergency rating) |
|--------------------------------------|--|

**Encina-San Luis Rey constraint**

The deliverability of portfolio resources in the Encina-San Luis Rey area is limited by thermal overloading of the Encina Tap-San Luis Rey 230 kV line as shown in Table F.17-4. The constraint was seen in the SSN scenario. Table F.17-3 shows the amount of portfolio generation that would be deliverable without any transmission upgrades.

The constraint can be mitigated by using the existing 230kV TL 23003 Encina-San Luis Rey/ TL 23011 Encina-San Luis Rey-Palomar RAS.

Table F.17-6: Encina-San Luis Rey deliverability constraint

| Overloaded Facility            | Contingency                | Highest Loading (%) |     |
|--------------------------------|----------------------------|---------------------|-----|
|                                |                            | HSN                 | SSN |
| Encina Tap-San Luis Rey 230 kV | San Luis Rey-Encina 230 kV | <100                | 110 |

Table F.17-7: Encina-San Luis Rey deliverability constraint summary

|  |                                     |   |
|--|-------------------------------------|---|
| Affected transmission zones  |                                     | Imperial Valley, ECO/BUE, SDGE Internal   |
| Portfolio resources behind the constraint (Installed FCDS capacity)            |                                     | 2990  |
| Portfolio battery storage behind the constraint (Installed FCDS capacity)      |                                     | 448   |
| Deliverable portfolio resources w/o mitigation (Installed FCDS capacity)       |                                     | 1783  |
| Total undeliverable baseline and portfolio resources (Installed FCDS capacity) |                                     | 1207  |
| Mitigation Options   | RAS                                 | Existing 230kV TL 23003 Encina-San Luis Rey/ TL 23011 Encina-San Luis Rey-Palomar RAS |
|  | Reduce generic battery storage (MW) | None  |
|  | Transmission upgrade including cost | Not needed  |
| Recommended Mitigation   |                                     | Existing 230kV TL 23003 Encina-San Luis Rey/ TL 23011 Encina-San Luis Rey-Palomar RAS |

|                   |              |
|-------------------|--------------|
| Affected inerties | IID-SDGE_ITC |
|-------------------|--------------|

|  |   |
|--|---|
| MIC expansion request MW behind constraint | 35  |
| Deliverable MIC expansion request MW       | 35<br>(Use existing 230kV TL 23003 Encina-San Luis Rey/ TL 23011 Encina-San Luis Rey-Palomar RAS) |

**San Luis Rey-San Onofre constraint**

The deliverability of portfolio resources in the San Luis Rey-San Onofre area is limited by thermal overloading of the San Luis Rey-San Onofre 230 kV #1 line as shown in Table F.17-8. The constraint was seen in the SSN scenario. Table F.17-9 shows the amount of portfolio generation that would be deliverable without any transmission upgrades.

The constraint can be mitigated by using the existing 230kV TL 23006 San Luis Rey-San Onofre RAS.

Table F.17-8: San Luis Rey-San Onofre deliverability constraint

| Overloaded Facility               | Contingency                              | Highest Loading (%) |     |
|-----------------------------------|--|---------------------|-----|
|                                   |  | HSN                 | SSN |
| San Luis Rey-San Onofre 230 kV #1 | San Luis Rey-San Onofre 230 kV #2 and #3 | <100                | 106 |

Table F.17-9: San Luis Rey-San Onofre deliverability constraint summary

|  |                                     |   |
|--|-------------------------------------|---|
| Affected transmission zones  |                                     | Imperial Valley, ECO/BUE, SDGE Internal, Arizona    |
| Portfolio resources behind the constraint (Installed FCDS capacity)            |                                     | 3800  |
| Portfolio battery storage behind the constraint (Installed FCDS capacity)      |                                     | 726   |
| Deliverable portfolio resources w/o mitigation (Installed FCDS capacity)       |                                     | 3325  |
| Total undeliverable baseline and portfolio resources (Installed FCDS capacity) |                                     | 475   |
| Mitigation Options   | RAS                                 | Existing 230kV TL 23006 San Luis Rey-San Onofre RAS |
|  | Reduce generic battery storage (MW) | Not sufficient                                      |
|  | Transmission upgrade including cost | Not needed  |
| Recommended Mitigation   |                                     | Existing 230kV TL 23006 San Luis Rey-San Onofre RAS |

|  |   |
|--|---|
| Affected interties                         | IID-SDGE_ITC  |
| MIC expansion request MW behind constraint | 35  |
| Deliverable MIC expansion request MW       | 35<br>(Use existing 230kV TL 23006 San Luis Rey-San Onofre RAS) |

**F.17.2 2034 Off-peak results**

The Off-peak deliverability assessment did not identify any constraints in the SDG&E area.

**F.17.3 2039 On-peak results**

**Old Town constraint**

The deliverability of portfolio resources in the Old Town area is limited by thermal overloading of the Old Town 230/69 kV transformers as shown in Table F.17-2. The constraint was seen in the 2039 Base scenario. Table F.17-3 shows the amount of portfolio generation that would be deliverable without any transmission upgrades.

These overloads were also observed in the reliability study, and the proposed Downtown Reliability Reinforcement project that was identified in that analysis also mitigates the overloads in in the deliveability assessment.

Table F.17-10: Old Town deliverability constraint

| Overloaded Facility   | Contingency           | Highest Loading (%) |             |
|-----------------------|-----------------------|---------------------|-------------|
|                       |                       | Base                | Sensitivity |
| Old Town 230/69 kV #1 | Old Town 230/69 kV #2 | 101                 | <100        |
| Old Town 230/69 kV #2 | Old Town 230/69 kV #1 | 101                 | <100        |

Table F.17-11: Old Town deliverability constraint summary

| Affected transmission zones  | N/A                             |             |
|--|---------------------------------|-------------|
|  | Base                            | Sensitivity |
| Portfolio resources behind the constraint (Installed FCDS capacity)            | No generation in 5% DFAX circle |             |
| Portfolio battery storage behind the constraint (Installed FCDS capacity)      |                                 |             |
| Deliverable portfolio resources w/o mitigation (Installed FCDS capacity)       |                                 |             |
| Total undeliverable baseline and portfolio resources (Installed FCDS capacity) |                                 |             |

|                        |                                     |  |
|------------------------|-------------------------------------|--|
| Mitigation Options     | RAS                                 | Downtown Reliability Reinforcement project (identified in reliability study) |
|                        | Reduce generic battery storage (MW) |  |
|                        | Transmission upgrade including cost |  |
| Recommended Mitigation |                                     |  |

|  |      |             |
|--|------|-------------|
| Affected interties                         | N/A  |             |
|  | Base | Sensitivity |
| MIC expansion request MW behind constraint | N/A  | N/A         |
| Deliverable MIC expansion request MW       | N/A  | N/A         |

**Sycamore-Scripps constraint**

The deliverability of portfolio resources in the Sycamore-Scripps area is limited by thermal overloading of the Sycamore-Scripps 69 kV line as shown in Table F.17-2. The constraint was seen in the 2039 Base and Sensitivity scenarios. Table F.17-3 shows the amount of portfolio generation that would be deliverable without any transmission upgrades.

The constraint can be mitigated by using the 30 minute emergency rating of the Sycamore-Scripps 69 kV line.

Table F.17-12: Sycamore-Scripps deliverability constraint

| Overloaded Facility    | Contingency   | Highest Loading (%) |             |
|------------------------|---|---------------------|-------------|
|                        |   | Base                | Sensitivity |
| Sycamore-Scripps 69 kV | Sycamore-Penasquitos 230 kV                                     | 113                 | 117         |
| Sycamore-Scripps 69 kV | Miramar GT-Miramar 69 kV  | 102                 | 103         |
| Sycamore-Scripps 69 kV | Sycamore-Penasquitos 230 kV and Mira Sorrento-Penasquitos 69 kV | 113                 | 117         |

Table F.17-13: Sycamore-Scripps constraint summary

|   |               |             |
|---|---------------|-------------|
| Affected transmission zones   | SDGE Internal |             |
|   | Base          | Sensitivity |
| Portfolio resources behind the constraint (Installed FCDS capacity)       | 591           | 601         |
| Portfolio battery storage behind the constraint (Installed FCDS capacity) | 101           | 101         |

|  |                                     |                                |     |
|--|-------------------------------------|--------------------------------|-----|
| Deliverable portfolio resources w/o mitigation (Installed FCDS capacity)       |                                     | 479                            | 489 |
| Total undeliverable baseline and portfolio resources (Installed FCDS capacity) |                                     | 113                            | 113 |
| Mitigation Options   | RAS                                 | None                           |     |
|  | Reduce generic battery storage (MW) | None                           |     |
|  | Transmission upgrade including cost | Not needed                     |     |
| Recommended Mitigation   |                                     | Use 30 minute emergency rating |     |

|  |      |             |
|--|------|-------------|
| Affected interties                         | N/A  |             |
|  | Base | Sensitivity |
| MIC expansion request MW behind constraint | N/A  | N/A         |
| Deliverable MIC expansion request MW       | N/A  | N/A         |

**Bay Boulevard-Silvergate constraint**

The deliverability of portfolio resources in the Bay Boulevard-Silvergate area is limited by thermal overloading of the Bay Boulevard-Silvergate 230 kV line as shown in Table F.17-2. The constraint was seen in the 2039 Sensitivity scenario. Table F.17-3 shows the amount of portfolio generation that would be deliverable without any transmission upgrades.

The constraint can be mitigated by using the 2-hour emergency rating of the Bay Boulevard-Silvergate 230 kV line.

Table F.17-14: Bay Boulevard-Silvergate deliverability constraint

| Overloaded Facility             | Contingency                     | Highest Loading (%) |             |
|---------------------------------|---------------------------------|---------------------|-------------|
|                                 |                                 | Base                | Sensitivity |
| Bay Boulevard-Silvergate 230 kV | Imperial Valley-NSONGS 500 kV   | <100                | 104         |
| Bay Boulevard-Silvergate 230 kV | Miguel-Mission 230 kV #1 and #2 | <100                | 103         |

Table F.17-15: Bay Boulevard-Silvergate deliverability constraint summary

|   |   |             |
|---|---|-------------|
| Affected transmission zones   | Imperial Valley, ECO/BUE, SDGE Internal |             |
|   | Base                                    | Sensitivity |
| Portfolio resources behind the constraint (Installed FCDS capacity) | 1579                                    | 3064        |



|  |                                     |                             |      |
|--|-------------------------------------|-----------------------------|------|
| Portfolio battery storage behind the constraint (Installed FCDS capacity)      |                                     | 342                         | 562  |
| Deliverable portfolio resources w/o mitigation (Installed FCDS capacity)       |                                     | 1579                        | 2699 |
| Total undeliverable baseline and portfolio resources (Installed FCDS capacity) |                                     | 0                           | 364  |
| Mitigation Options   | RAS                                 | None                        |      |
|  | Reduce generic battery storage (MW) | None                        |      |
|  | Transmission upgrade including cost | Not needed                  |      |
| Recommended Mitigation   |                                     | Use 2 hour emergency rating |      |

|  |                                     |             |
|--|-------------------------------------|-------------|
| Affected interties                         | IID-SDGE_ITC                        |             |
|  | Base                                | Sensitivity |
| MIC expansion request MW behind constraint | 35                                  | N/A         |
| Deliverable MIC expansion request MW       | 35<br>(Use 2 hour emergency rating) | N/A         |

**Silvergate-Old Town constraint**

The deliverability of portfolio resources in the Silvergate-Old Town area is limited by thermal overloading of the Silvergate-Old Town 230 kV lines as shown in Table F.17-2. The constraint was seen in the 2039 Sensitivity scenario. Table F.17-3 shows the amount of portfolio generation that would be deliverable without any transmission upgrades.

The constraint can be mitigated by using the 30 minute rating of the overloaded lines.

Table F.17-16: Silvergate-Old Town deliverability constraint

| Overloaded Facility        | Contingency  | Highest Loading (%) |             |
|----------------------------|--|---------------------|-------------|
|                            |  | Base                | Sensitivity |
| Silvergate-Old Town 230 kV | Old Town-Mission 230 kV and Silvergate-Mission-Old Town 230 kV | <100                | 101         |

Table F.17-17: Silvergate-Old Town deliverability constraint summary

|   |   |             |
|---|---|-------------|
| Affected transmission zones   | Imperial Valley, ECO/BUE, SDGE Internal |             |
|   | Base                                    | Sensitivity |
| Portfolio resources behind the constraint (Installed FCDS capacity) | 1303                                    | 1971        |

|  |                                     |                                |      |
|--|-------------------------------------|--------------------------------|------|
| Portfolio battery storage behind the constraint (Installed FCDS capacity)      |                                     | 236                            | 236  |
| Deliverable portfolio resources w/o mitigation (Installed FCDS capacity)       |                                     | 1303                           | 1862 |
| Total undeliverable baseline and portfolio resources (Installed FCDS capacity) |                                     | 0                              | 109  |
| Mitigation Options   | RAS                                 | None                           |      |
|  | Reduce generic battery storage (MW) | None                           |      |
|  | Transmission upgrade including cost | Not needed                     |      |
| Recommended Mitigation   |                                     | Use 30 minute emergency rating |      |

|  |      |             |
|--|------|-------------|
| Affected interties                         | N/A  |             |
|  | Base | Sensitivity |
| MIC expansion request MW behind constraint | N/A  | N/A         |
| Deliverable MIC expansion request MW       | N/A  | N/A         |

**Encina-San Luis Rey constraint**

The deliverability of portfolio resources in the Encina-San Luis Rey area is limited by thermal overloading of the Encina Tap-San Luis Rey 230 kV line as shown in Table F.17-2. The constraint was seen in the 2039 Sensitivity scenario. Table F.17-3 shows the amount of portfolio generation that would be deliverable without any transmission upgrades.

The constraint can be mitigated by using the existing 230kV TL 23003 Encina-San Luis Rey/ TL 23011 Encina-San Luis Rey-Palomar RAS.

Table F.17-18: Encina-San Luis Rey deliverability constraint

| Overloaded Facility            | Contingency                           | Highest Loading (%) |             |
|--------------------------------|---------------------------------------|---------------------|-------------|
|                                |                                       | Base                | Sensitivity |
| Encina Tap-San Luis Rey 230 kV | San Luis Rey-Encina 230 kV            | <100                | 103         |
| Encina Tap-San Luis Rey 230 kV | Imperial Valley-North of SONGS 500 kV | <100                | 102         |

Table F.17-19: Encina-San Luis Rey deliverability constraint summary

|                             |   |             |
|-----------------------------|---|-------------|
| Affected transmission zones | Imperial Valley, ECO/BUE, SDGE Internal |             |
|                             | Base                                    | Sensitivity |

|  |                                     |   |      |
|--|-------------------------------------|---|------|
| Portfolio resources behind the constraint (Installed FCDS capacity)            |                                     | 3196  | 4646 |
| Portfolio battery storage behind the constraint (Installed FCDS capacity)      |                                     | 1052  | 1271 |
| Deliverable portfolio resources w/o mitigation (Installed FCDS capacity)       |                                     | 3196  | 4348 |
| Total undeliverable baseline and portfolio resources (Installed FCDS capacity) |                                     | 0   | 298  |
| Mitigation Options   | RAS                                 | Existing 230kV TL 23003 Encina-San Luis Rey/ TL 23011 Encina-San Luis Rey-Palomar RAS |      |
|  | Reduce generic battery storage (MW) | Not sufficient  |      |
|  | Transmission upgrade including cost | Not needed  |      |
| Recommended Mitigation   |                                     | Existing 230kV TL 23003 Encina-San Luis Rey/ TL 23011 Encina-San Luis Rey-Palomar RAS |      |

| Affected interties                         | IID-SDGE_ITC  |             |
|--|---|-------------|
|  | Base  | Sensitivity |
| MIC expansion request MW behind constraint | 35  | N/A         |
| Deliverable MIC expansion request MW       | 35<br>(Use existing 230kV TL 23003 Encina-San Luis Rey/ TL 23011 Encina-San Luis Rey-Palomar RAS) | N/A         |

**Escondido-San Marcos constraint**

The deliverability of portfolio resources in the Escondido-San Marcos area is limited by thermal overloading of the Escondido-San Marcos 69 kV line as shown in Table F.17-20. The constraint was seen in the 2039 Sensitivity scenario. Table F.17-3 shows the amount of portfolio generation that would be deliverable without any transmission upgrades.

The constraint can be mitigated by using the existing 230kV TL 23003 Encina-San Luis Rey/ TL 23011 Encina-San Luis Rey-Palomar RAS.

Table F.17-20: Encina-San Luis Rey deliverability constraint

| Overloaded Facility        | Contingency   | Highest Loading (%) |             |
|----------------------------|---|---------------------|-------------|
|                            |   | Base                | Sensitivity |
| Escondido-San Marcos 69 kV | San Luis Rey-Encina 230 kV and San Luis Rey-Encina-Palomar 230 kV | <100                | 106         |

Table F.17-21: Encina-San Luis Rey deliverability constraint summary

| Affected transmission zones  |                                     | Imperial Valley, ECO/BUE, SDGE Internal   |             |
|--|-------------------------------------|---|-------------|
|  |                                     | Base  | Sensitivity |
| Portfolio resources behind the constraint (Installed FCDS capacity)            |                                     | 634   | 643         |
| Portfolio battery storage behind the constraint (Installed FCDS capacity)      |                                     | 143   | 143         |
| Deliverable portfolio resources w/o mitigation (Installed FCDS capacity)       |                                     | 634   | 521         |
| Total undeliverable baseline and portfolio resources (Installed FCDS capacity) |                                     | 0   | 122         |
| Mitigation Options   | RAS                                 | Existing 230kV TL 23003 Encina-San Luis Rey/ TL 23011 Encina-San Luis Rey-Palomar RAS |             |
|  | Reduce generic battery storage (MW) | None  |             |
|  | Transmission upgrade including cost | Not needed  |             |
| Recommended Mitigation   |                                     | Existing 230kV TL 23003 Encina-San Luis Rey/ TL 23011 Encina-San Luis Rey-Palomar RAS |             |

| Affected interties                         | N/A  |             |
|--|------|-------------|
|  | Base | Sensitivity |
| MIC expansion request MW behind constraint | N/A  | N/A         |
| Deliverable MIC expansion request MW       | N/A  | N/A         |

**F.17.4 Conclusion and recommendation**

The SDG&E area base and sensitivity portfolios deliverability assessment identified on peak constraints. These constraints can be mitigated by using existing RAS and emergency ratings of

the overloaded lines. The off-peak deliverability assessment did not identify any constraints. Transmission upgrades in the SDG&E area are not found to be needed in this planning cycle.

## F.18 Out-of-State Wind

In the CPUC submitted portfolios for Out of State wind (OOS) resources for the 2024-2025 TPP, there is a total of approximately 6 GW for 2034 and 9 GW for 2039 in the base portfolios. For 2034, the base portfolio includes 1,060 MW from Idaho, 2,905 MW from Wyoming, and 2,131 MW from New Mexico. For 2039, in the base portfolio, in addition to these amounts, there is an additional 1,500 MW from Wyoming and an additional 1,405 MW from New Mexico. All the required MW amounts require developing new transmission as well as transmission upgrades within the ISO footprint.

Based on transmission projects approved in the 2022-2023 TPP, the three transmission projects namely SWIP-North, TWE, and SunZia combined help in integrating 5,700 MW of OOS resources from Idaho, Wyoming, and New Mexico. It should also be noted that the scheduling rights for Sunzia from Pinal Central to Palo Verde is about 2,131 MW. The 2039 base portfolio has 3,536 MW New Mexico wind which equals 2,369 MW study amount. After taking into account 5% lost factor on HVDC line, there is still not enough scheduling right from Pinal Central to Palo Verde. The ISO needs to determine additional transmission projects that would be needed to integrate the additional amounts of wind resources from Wyoming and New Mexico. The ISO is not proposing the approval of any transmission project or upgrade in the 2024-2025 TPP for integrating additional OOS resources from Wyoming and New Mexico. This is also consistent with the CPUC Decision 25-02-026<sup>27</sup> issued on February 20, 2025 not to trigger upgrades related to the additional OOS wind amounts in the portfolio that are beyond the amounts that can be accommodated on the already-identified and in-development transmission upgrades.

The ISO will undertake a special study of the various routes and combinations for the OOS wind amounts to learn more information about the details of potential routes. This will allow for analysis of alternative locations for injecting the resources onto the CAISO grid and the potential transmission solutions. Moreover, the ISO will coordinate with CPUC staff as it pursues additional modeling with new OOS wind profiles and cost estimates to confirm the need for the high level of OOS wind. Engagement with utilities in the West to seek mutually beneficial transmission solutions and results from the WestTEC studies will also help inform the ISO as it works towards developing transmission solutions to integrate additional OOS resources.

While the ISO is working on transmission solutions to integrate additional OOS wind resources, it must be noted that in order to support the 1500 MW of Wyoming wind interconnecting to Tesla 500 kV in 2039, the ISO is relying on a Tesla substation expansion project identified through the generator interconnection process. Additional analysis will be performed in future cycles to evaluate if additional updates to this project are required.

---

<sup>27</sup> <https://docs.cpuc.ca.gov/PublishedDocs/Published/G000/M557/K879/557879249.PDF>

Northern California Wind was evaluated as part of the 2024-2025 TPP. The amount of generation currently mapped (900 MW) will be able to be supported through existing transmission however significant increases to the generation may require additional transmission to deliver the generation to CAISO system. This will be evaluated in future cycles.

## **F.19 Transmission Plan Deliverability with Approved Transmission Upgrades**

As part of the coordination with other ISO processes and as set out in Appendix DD (GIDAP) of the ISO tariff, the ISO monitors the available transmission plan deliverability (TPD) in areas where the amount of generation in the interconnection queue exceeds the available deliverability, as identified in the generator interconnection cluster studies. In areas where the amount of generation in the interconnection queue is less than the available deliverability, the transmission plan deliverability is sufficient. An estimate of the generation deliverability supported by the existing system and approved upgrades is provided in the transmission capability estimates white paper the ISO published in August 2024<sup>28</sup>. The white paper considered queue clusters up to and including queue cluster 14. The transmission plan deliverability is estimated based on the area deliverability constraints identified in recent generation interconnection studies without considering local deliverability constraints.

## **F.20 Production cost model (PCM) results**

The CPUC IRP portfolios described in section F.4 were used to develop planning PCM cases that were used for both policy and economic assessments. Transmission congestion and renewable curtailment were assessed in the PCM studies. Details of PCM development and study results can be found in Chapter 4 and Appendix G.

---

<sup>28</sup> <https://www.caiso.com/library/transmission-capability-estimate-inputs-for-cpuc-integrated-resource-plan-aug-29-2024>