



Business Requirements Specification

Extended Day Ahead Market

Document Version: ~~4-6~~1.7

Current Version Date: ~~1/27/2026~~3/26/2026

 California ISO	Technology	Template Version:	6.8
		Document Version:	6.1.7
Extended Day Ahead Market Business Requirements Specification - Planning		Date Created:	1/21/2026

Revision History

Date	Version	Description
8/1/2023	1.0	Initial Document Release.
12/22/2023	1.1	<p>Section 5.1 Updates</p> <ul style="list-style-type: none"> • Updated BRQs <ul style="list-style-type: none"> ○ BRQ-02010, BRQ-02030, BRQ-02040, BRQ-02042, BRQ-02044, BRQ-02050, BRQ-02051, BRQ-02054, BRQ-02080, BRQ-02082, BRQ-02083, BRQ-02085, BRQ-02100, BRQ-02102, BRQ-02120, BRQ-02130, BRQ-02140, BRQ-02141, BRQ-02142, BRQ-02150, BRQ-02185 • New BRQs <ul style="list-style-type: none"> ○ BRQ-02041, BRQ-02083a, BRQ-02083b, BRQ-02089a, BRQ-02146, 02250 • Removed BRQs <ul style="list-style-type: none"> ○ BRQ-02200 <p>Section 5.2 Updates</p> <ul style="list-style-type: none"> • Updated BRQs <ul style="list-style-type: none"> ○ BRQ-04010b, BRQ-04012, BRQ-04013, BRQ-04020a, BRQ-04021, BRQ-04051, BRQ-04052, BRQ-04053, BRQ-04054, BRQ-04058, BRQ-04059, BRQ-04060, BRQ-04065 • New BRQs <ul style="list-style-type: none"> ○ BRQ-04032, BRQ-04040 <p>Section 5.3 Updates</p> <ul style="list-style-type: none"> • Updated BRQs <ul style="list-style-type: none"> ○ BRQ-05020, BRQ-05050, BRQ-05080 <p>Section 5.4 Updates</p> <ul style="list-style-type: none"> • Updated BRQs <ul style="list-style-type: none"> ○ BRQ-08020, BRQ-08030, BRQ-08040, BRQ-08050, BRQ-08080, BRQ-08130 • New BRQs <ul style="list-style-type: none"> ○ BRQ-08135 <p>Section 5.5 Updates</p> <ul style="list-style-type: none"> • Updated BRQs <ul style="list-style-type: none"> ○ BRQ-11010, BRQ-11013, BRQ-11015, BRQ-11030, BRQ-11054, BRQ-11055, BRQ-11060, BRQ-11070, BRQ-11080, BRQ-11100, BRQ-11102, BRQ-11110, BRQ-11120, BRQ-11130, BRQ-11140, BRQ-11170, BRQ-11172, BRQ-11180, BRQ-11190, BRQ-11210, BRQ-11222, BRQ-11250, BRQ-11260, BRQ-11290 • New BRQs <ul style="list-style-type: none"> ○ BRQ-11054a, BRQ-11055a, BRQ-11058, BRQ-11058a, BRQ-11059, BRQ-11099, BRQ-11101, BRQ-11103, BRQ-11112, BRQ-11280, BRQ-11291, BRQ-11295 <p>Section 5.6 Updates</p>

 California ISO	Technology	Template Version:	6.8
		Document Version:	4.6 1.7
Extended Day Ahead Market Business Requirements Specification - Planning		Date Created:	1/21/2026

Date	Version	Description
		<ul style="list-style-type: none"> • Updated BRQs <ul style="list-style-type: none"> ○ BRQ-12008, BRQ-2016D, BRQ-1203a, BRQ-12040, BRQ-12080, BRQ-12090, BRQ-12110, BRQ-12150, BRQ-12160, BRQ- • New BRQs <ul style="list-style-type: none"> ○ BRQ-12016A, BRQ-12016B, BRQ-12017, BRQ-12020, BRQ-12030 <p>Section 5.7 Updates</p> <ul style="list-style-type: none"> • Updated BRQs <ul style="list-style-type: none"> ○ BRQ-13020, BRQ-13050, BRQ-13052, BRQ-13070, BRQ-13095, BRQ-13100, BRQ-13130, BRQ-13162 • New BRQs <ul style="list-style-type: none"> ○ BRQ-13060a, BRQ-13060b, BRQ-13060c, BRQ-13060d, BRQ-13161 <p>Section 5.8 Updates</p> <ul style="list-style-type: none"> • Updated BRQs <ul style="list-style-type: none"> ○ BRQ-14010, BRQ-14074 • New BRQs <ul style="list-style-type: none"> ○ BRQ-14014 <p>Section 5.9 Updates</p> <ul style="list-style-type: none"> • Updated BRQs <ul style="list-style-type: none"> ○ BRQ-15010, BRQ-15060, BRQ-15063, BRQ-15071, BRQ-15200 <p>Section 5.10 Updates</p> <ul style="list-style-type: none"> • Updated BRQs <ul style="list-style-type: none"> ○ BRQ-16020, BRQ-16065, BRQ-16090, BRQ-16100 • New BRQs <ul style="list-style-type: none"> ○ BRQ-16016, BRQ-16088, BRQ-16104, BRQ-16112a, BRQ-16112b, BRQ-13112c, BRQ-16112d, BRQ-16140 <p>Section 5.11 Updates</p> <ul style="list-style-type: none"> • Updated BRQs <ul style="list-style-type: none"> ○ BRQ-17020, BRQ-17030, BRQ-17040, BRQ-17050, BRQ-17060, BRQ-17070a, BRQ-17080, BRQ-17090, BRQ-17110, BRQ-17120, BRQ-17200, BRQ-17210 • New BRQs <ul style="list-style-type: none"> ○ BRQ-17022, BRQ-17070, BRQ-17122 • Removed BRQs <ul style="list-style-type: none"> ○ BRQ-17220 <p>Section 5.12 Updates</p> <ul style="list-style-type: none"> • New BRQs <ul style="list-style-type: none"> ○ BRQ-18530, BRQ-18535, BRQ-18545, BRQ-18547, BRQ-18550 <p>Section 5.13 Updates</p> <ul style="list-style-type: none"> • Updated BRQs

 California ISO	Technology	Template Version:	6.8
		Document Version:	6.1.7
Extended Day Ahead Market Business Requirements Specification - Planning		Date Created:	1/21/2026

Date	Version	Description
		<ul style="list-style-type: none"> ○ BRQ-19010, BRQ-19014, BRQ-19022, BRQ-19026, BRQ-19050, BRQ-19052, BRQ-19063, BRQ-19075, BRQ-19110, BRQ-19115, BRQ-19120, BRQ-19130, BRQ-19140, BRQ-19150, BRQ-19160, BRQ-19170, BRQ-19172, BRQ-19175, BRQ-19240, BRQ-19274, BRQ-19288, BRQ-19298, BRQ-19370, BRQ-19380, BRQ-19400, BRQ-19430, BRQ-19430 ● New BRQs <ul style="list-style-type: none"> ○ BRQ-19042, BRQ-19051, BRQ-19055, BRQ-19056, BRQ-19490, BRQ-19500 ● Removed BRQs <ul style="list-style-type: none"> ○ BRQ-19180, BRQ-19182, BRQ-19190, BRQ-19300, BRQ-19310, BRQ-19320, BRQ-19330, BRQ-19340, BRQ-19350, BRQ-19360, BRQ-19362 <p>Section 5.14 Updates</p> <ul style="list-style-type: none"> ● Updated BRQs <ul style="list-style-type: none"> ○ BRQ-20000, BRQ-20013, BRQ-20023, BRQ-20030, BRQ-20050, BRQ-20052, BRQ-20054, BRQ-20062, BRQ-20065, BRQ-20070, BRQ-20082, BRQ-20100, BRQ-20110, BRQ-20120, BRQ-20130, BRQ-20140 ● New BRQs <ul style="list-style-type: none"> ○ BRQ-20010, BRQ-20011, BRQ-20020, BRQ-20022, BRQ-20024, BRQ-20031, BRQ-20051, BRQ-50053, BRQ-20057, BRQ-20068, BRQ-20084, BRQ-20150, BRQ-20156, BRQ-2245, BRQ-20260 <p>Section 5.15 Updates</p> <ul style="list-style-type: none"> ● Updated BRQs <ul style="list-style-type: none"> ○ BRQ-20230, BRQ-20240 ● New BRQs <ul style="list-style-type: none"> ○ BRQ-20227, BRQ-20242 <p>Section 5.16 Updates</p> <ul style="list-style-type: none"> ● Updated BRQs <ul style="list-style-type: none"> ○ BRQ-22049, BRQ-22050 <p>Section 5.17 Updates</p> <ul style="list-style-type: none"> ● Updated BRQs <ul style="list-style-type: none"> ○ BRQ-24020, BRQ-24040, BRQ-24060, BRQ-24080, BRQ-24100, BRQ-24120, BRQ-24140, BRQ-24160, BRQ-24220, BRQ-24240
04/23/2024	1.2	<p>Updates by Topic:</p> <ul style="list-style-type: none"> ● Removal of TSR commodity ● DR Inclusion in Forecasting ● Removal of GHG losses ● RUC model updates ● Additional miscellaneous BRQ updates <p>Updates by Section/Individual Requirements:</p> <p>Section 5.1 Updates</p>

 California ISO	Technology	Template Version:	6.8
		Document Version:	4.6 1.7
Extended Day Ahead Market Business Requirements Specification - Planning		Date Created:	1/21/2026

Date	Version	Description
		<ul style="list-style-type: none"> • Updated BRQs <ul style="list-style-type: none"> ○ BRQ-02089a, BRQ-02142, BRQ-02190 • New BRQs <ul style="list-style-type: none"> ○ BRQ-02087, BRQ-02260 • Removed BRQs <ul style="list-style-type: none"> ○ BRQ-02120 <p>Section 5.2 Updates</p> <ul style="list-style-type: none"> • Updated BRQs <ul style="list-style-type: none"> ○ BRQ-04041, BRQ-04052, BRQ-04058, BRQ-04060 • Removed BRQs <ul style="list-style-type: none"> ○ BRQ-04054, BRQ-04059 <p>Section 5.3 Updates</p> <ul style="list-style-type: none"> • New BRQs <ul style="list-style-type: none"> ○ BRQ-05075 <p>Section 5.4 Updates</p> <ul style="list-style-type: none"> • Updated BRQs <ul style="list-style-type: none"> ○ BRQ-08060 <p>Section 5.5 Updates</p> <ul style="list-style-type: none"> • Updated BRQs <ul style="list-style-type: none"> ○ BRQ-11010, BRQ-11014, BRQ-11054, BRQ-11150, BRQ-11190 • New BRQs <ul style="list-style-type: none"> ○ BRQ-11022, BRQ-11106, BRQ-11150a <p>Section 5.6 Updates</p> <ul style="list-style-type: none"> • Updated BRQs <ul style="list-style-type: none"> ○ BRQ-12008, BRQ-12016D, BRQ-12040, BRQ-12050, BRQ-12180, BRQ-12030 • New BRQs <ul style="list-style-type: none"> ○ BRQ-12016 • Removed BRQs <ul style="list-style-type: none"> ○ BRQ-12016A, BRQ-12016B <p>Section 5.7 Updates</p> <ul style="list-style-type: none"> • Updated BRQs <ul style="list-style-type: none"> ○ BRQ-13052, BRQ-13054, BRQ-13060a, BRQ-13080, BRQ-13100, BRQ-13120 • Removed BRQs <ul style="list-style-type: none"> ○ BRQ-13130 <p>Section 5.8 Updates</p> <ul style="list-style-type: none"> • Updated BRQs <ul style="list-style-type: none"> ○ BRQ-14010, BRQ-14020, BRQ-14030, BRQ-14042 • Removed BRQs <ul style="list-style-type: none"> ○ BRQ-14040

 California ISO	Technology	Template Version:	6.8
		Document Version:	4.6 1.7
Extended Day Ahead Market Business Requirements Specification - Planning		Date Created:	1/21/2026

Date	Version	Description
		<p>Section 5.9 Updates</p> <ul style="list-style-type: none"> No changes to BRQs <p>Section 5.10 Updates</p> <ul style="list-style-type: none"> Updated BRQs <ul style="list-style-type: none"> BRQ-16015, BRQ-16030, BRQ-16062 <p>Section 5.11 Updates</p> <ul style="list-style-type: none"> Updated BRQs <ul style="list-style-type: none"> BRQ-17030, BRQ-17070a, BRQ-17200, BRQ-17210 New BRQs <ul style="list-style-type: none"> BRQ-17230 Removed BRQs <ul style="list-style-type: none"> BRQ-17022 <p>Section 5.12 Updates</p> <ul style="list-style-type: none"> No changes to BRQs <p>Section 5.13 Updates</p> <ul style="list-style-type: none"> Updated BRQs <ul style="list-style-type: none"> BRQ-19024, BRQ-19026, BRQ-19030, BRQ-19400, BRQ-19420 New BRQs <ul style="list-style-type: none"> BRQ-19025, BRQ-19063a <p>Section 5.14 Updates</p> <ul style="list-style-type: none"> Updated BRQs <ul style="list-style-type: none"> BRQ-20010, BRQ-20011, BRQ-20013, BRQ-20050, BRQ-20051, BRQ-20054, BRQ-20068, BRQ-20070, BFQ-20080, BRQ-20082 New BRQs <ul style="list-style-type: none"> BRQ-20145 Removed BRQs <ul style="list-style-type: none"> BRQ-20052, BRQ-20053, BRQ-20062 <p>Section 5.15 Updates</p> <ul style="list-style-type: none"> Removed BRQs <ul style="list-style-type: none"> BRQ-20242 <p>Section 5.16 Updates</p> <ul style="list-style-type: none"> No changes to BRQs <p>Section 5.17 Updates</p> <ul style="list-style-type: none"> No changes to BRQs
08/05/2024	1.3	<p>Section 1.3 Updates</p> <ul style="list-style-type: none"> Clarified RUC scope item <p>Section 5.1 Updates</p>

 California ISO	Technology	Template Version:	6.8
		Document Version:	6.1.7
Extended Day Ahead Market Business Requirements Specification - Planning		Date Created:	1/21/2026

Date	Version	Description
		<ul style="list-style-type: none"> • Updated BRQs: <ul style="list-style-type: none"> • BRQ-02060 (Clarify ISO vs. EDAM BAA RSE participation rules) • BRQ-02180 (Updates to GMC definition based on 2023 Cost of Service Initiative) • New BRQs: <ul style="list-style-type: none"> • BRQ-02270 (Define AS regions for each EDAM BAA) <p>Section 5.2 Updates</p> <ul style="list-style-type: none"> • No changes to BRQs <p>Section 5.2 Updates</p> <ul style="list-style-type: none"> • No changes to BRQs <p>Section 5.4 Updates</p> <ul style="list-style-type: none"> • Updated BRQs: <ul style="list-style-type: none"> • BRQ-08040 (Updates to account for GMC definition based on 2023 Cost of Service Initiative) • BRQ-08132 (Changed from “Core” to “Existing”) • Removed BRQs: <ul style="list-style-type: none"> • BRQ-08130 (Redundant/unnecessary-covered under BRQ-08040) <p>Section 5.5 Updates</p> <ul style="list-style-type: none"> • Updated BRQs: <ul style="list-style-type: none"> • BRQ-11058a (Removed RTBS as impacted system) • BRQ-11260 (Removed AIM as impacted system, clarification) • BRQ-11295 (Changed “clean bids” to “bid-in quantity”) • New BRQs: <ul style="list-style-type: none"> • BRQ-11261 (EDAM Entity submission of CRN entitlement updates) <p>Section 5.6 Updates</p> <ul style="list-style-type: none"> • Updated BRQs: <ul style="list-style-type: none"> • BRQ-12090 (Removal of “TBD: or each BAA” for RSE optimization) <p>Section 5.7 Updates</p> <ul style="list-style-type: none"> • Updated BRQs: <ul style="list-style-type: none"> • BRQ-13052 (Removal of Settlements as impacted system, clarifications regarding EDAM disruption rules) • New BRQs: <ul style="list-style-type: none"> • BRQ-13052a (Additional details for EDAM disruption procedure) <p>Section 5.8 Updates</p> <ul style="list-style-type: none"> • Updated BRQs: <ul style="list-style-type: none"> • BRQ-14020 (Clarify constraint interactions in RUC) <p>Section 5.9 Updates</p> <ul style="list-style-type: none"> • Updated BRQs:

 California ISO	Technology	Template Version:	6.8
		Document Version:	4.61.7
Extended Day Ahead Market Business Requirements Specification - Planning		Date Created:	1/21/2026

Date	Version	Description
		<ul style="list-style-type: none"> • BRQ-15050 (Clarify hourly TSR award tagging as EDAM Entity responsibility) <p>Section 5.10 Updates</p> <ul style="list-style-type: none"> • No changes to BRQs <p>Section 5.11 Updates</p> <ul style="list-style-type: none"> • No changes to BRQs <p>Section 5.12 Updates</p> <ul style="list-style-type: none"> • Updated BRQs: <ul style="list-style-type: none"> • BRQ-18140 (Clarification to change calculation of hourly DA forecasted movement from “resource specific” to “nodal, by SC”) <p>Section 5.13 Updates</p> <ul style="list-style-type: none"> • Updated BRQs: <ul style="list-style-type: none"> • BRQ-19298 (Updates to GMC configuration based on 2023 Cost of Service Initiative) • BRQ-19510, BRQ-19520, BRQ-19530 (AS Settlements details/clarifications) • New BRQs: EDAM Access Charge Requirements <ul style="list-style-type: none"> • BRQ-19300, BRQ-19301, BRQ-19302, BRQ-19305, BRQ-19310, BRQ-19310a, BRQ-19310b, BRQ-19310c, BRQ-19320, BRQ-19330, BRQ-19330a, BRQ-19330b, BRQ-19330c, BRQ-19340a, BRQ-19340b, BRQ-19340c, BRQ-19350a, BRQ-19350b, BRQ-19350c, BRQ-19360, BRQ-19361, BRQ-19362, BRQ-19364, BRQ-19365 <p>Section 5.14 Updates</p> <ul style="list-style-type: none"> • Updated BRQs: <ul style="list-style-type: none"> • BRQ-20050, BRQ-20051, BRQ-20070 (Removed “10 am” to make requirements less prescriptive) • BRQ-20054 (Updated list of reports to be accessible to EDAM entity) • BRQ-20082 (Changed requirement “movement” to requirement “transfer) • BRQ-20245 (Removed details to make requirement less prescriptive) <p>Section 5.15 Updates</p> <ul style="list-style-type: none"> • No changes to BRQs <p>Section 5.16 Updates</p> <ul style="list-style-type: none"> • No changes to BRQs <p>Section 5.17 Updates</p> <ul style="list-style-type: none"> • Updated BRQs: <ul style="list-style-type: none"> • MSIM-BRQ-2040 (Detail added) • MSIM-BRQ-24120 (Changed “Entity” to “SC”) • MSIM-BRQ24220 (Changed EDAM “Administrative Charge” to EDAM “GMC”) <p>Added Appendix A8: EDAM Access Charge Illustrative Example</p>

 California ISO	Technology	Template Version:	6.8
		Document Version:	4-6 1.7
Extended Day Ahead Market Business Requirements Specification - Planning		Date Created:	1/21/2026

Date	Version	Description
3/13/2025	1.4	<p>Updates by Topic:</p> <ul style="list-style-type: none"> • New Inter-SC Trade BRQs (identified in BRQ ID with “IST”) • New of SP-TIE BRQs (functionality extended from DAME) • New TSR Model BRQ (identified in BRQ ID with “TSR”), removal of old TSR Model BRQs • GHG Model Clarifications • Additional minor clarifications throughout <p>Updates by Section/Individual Requirements:</p> <p>Section 5.1 Updates</p> <ul style="list-style-type: none"> • Updated BRQs <ul style="list-style-type: none"> ○ EDAM-BRQ-02087, EDAM-BRQ-02130, EDAM-BRQ-02141 • New BRQs <ul style="list-style-type: none"> ○ EDAM-IST-BRQ-02280, EDAM-TSR-BRQ-02051a, EDAM-TSR-BRQ-02051b, EDAM-TSR-BRQ-02051c, EDAM-TSR-BRQ-02051d, EDAM-TSR-BRQ-02051e, EDAM-TSR-BRQ-02051f, EDAM-TSR-BRQ-02051g, EDAM-TSR-BRQ-02100, EDAM-TSR-BRQ-02315, EDAM-TSR-BRQ-02316, EDAM-TSR-BRQ-02317, EDAM-TSR-BRQ-02318, EDAM-BRQ-02290 • Removed BRQs <ul style="list-style-type: none"> ○ EDAM-BRQ-02110 <p>Section 5.2 Updates</p> <ul style="list-style-type: none"> • Updated BRQs <ul style="list-style-type: none"> ○ EDAM-BRQ-04052, EDAM-BRQ-04058 • New BRQs <ul style="list-style-type: none"> ○ EDAM-BRQ-04052a • Removed BRQs <ul style="list-style-type: none"> ○ EDAM-BRQ-04041 <p>Section 5.3 Updates</p> <ul style="list-style-type: none"> • No changes to BRQs <p>Section 5.4 Updates</p> <ul style="list-style-type: none"> • Updated BRQs <ul style="list-style-type: none"> ○ EDAM-BRQ-08060 • New BRQs <ul style="list-style-type: none"> ○ EDAM-BRQ-08018 <p>Section 5.5 Updates</p> <ul style="list-style-type: none"> • Updated BRQs <ul style="list-style-type: none"> ○ EDAM-BRQ-11210, EDAM-BRQ-11295 • New BRQs <ul style="list-style-type: none"> ○ EDAM-BRQ-11100a, EDAM-IST-BRQ-11400, EDAM-IST-BRQ-11410, EDAM-IST-BRQ-11420, EDAM-IST-BRQ-11430, EDAM-IST-BRQ-11440, EDAM-IST-BRQ-

 California ISO	Technology	Template Version:	6.8
		Document Version:	6.1.7
Extended Day Ahead Market Business Requirements Specification - Planning		Date Created:	1/21/2026

Date	Version	Description
		<p>11450, EDAM-IST-BRQ-11460, EDAM-IST-BRQ-11470, EDAM-IST-BRQ-11480, EDAM-IST-BRQ-11490, EDAM-IST-BRQ-11500, EDAM-IST-BRQ-11510, EDAM-IST-BRQ-11520, EDAM-IST-BRQ-11530, EDAM-TSR-BRQ-11139a, EDAM-TSR-BRQ-11140, EDAM-TSR-BRQ-11141a, EDAM-TSR-BRQ-11141b, EDAM-TSR-BRQ-11141c, EDAM-TSR-BRQ-11141e, EDAM-TSR-BRQ-11141f, EDAM-TSR-BRQ-11142a, EDAM-TSR-BRQ-11142b, EDAM-TSR-BRQ-11144b, EDAM-TSR-BRQ-11144d, EDAM-TSR-BRQ-11144e, EDAM-TSR-BRQ-11144f, EDAM-TSR-BRQ-11144h, EDAM-TSR-BRQ-11145a, EDAM-TSR-BRQ-11145b, EDAM-TSR-BRQ-11145c, EDAM-TSR-BRQ-11146a, EDAM-TSR-BRQ-11146b, EDAM-TSR-BRQ-11146c, EDAM-TSR-BRQ-11161, EDAM-TSR-BRQ-11155, EDAM-TSR-BRQ-11156, EDAM-TSR-BRQ-11170, EDAM-TSR-BRQ-11165, EDAM-TSR-BRQ-11166, EDAM-TSR-BRQ-11175, EDAM-TSR-BRQ-11176, EDAM-TSR-BRQ-11180</p> <ul style="list-style-type: none"> • Removed BRQs <ul style="list-style-type: none"> ○ EDAM-BRQ-11014, EDAM-BRQ-11180, EDAM-BRQ-11190, EDAM-BRQ-11261 <p>Section 5.6 Updates</p> <ul style="list-style-type: none"> • Updated BRQs <ul style="list-style-type: none"> ○ EDAM-BRQ-12170 • New BRQs <ul style="list-style-type: none"> ○ EDAM-BRQ-12150a, EDAM-TSR-BRQ-12039 • Removed BRQs <ul style="list-style-type: none"> ○ EDAM-BRQ-12110 <p>Section 5.7 Updates</p> <ul style="list-style-type: none"> • Updated BRQs <ul style="list-style-type: none"> ○ EDAM-BRQ-13060c, EDAM-BRQ-13162 • New BRQs <ul style="list-style-type: none"> ○ EDAM-BRQ-13025, EDAM-BRQ-13052b, EDAM-BRQ-13285, EDAM-BRQ-13290, EDAM-TSR-BRQ-12043, EDAM-TSR-BRQ-12044, EDAM-TSR-BRQ-12045b, EDAM-TSR-BRQ-12046, EDAM-TSR-BRQ-12047 <p>Section 5.8 Updates</p> <ul style="list-style-type: none"> • New BRQs <ul style="list-style-type: none"> ○ EDAM-BRQ-14055, EDAM-BRQ-14056 <p>Section 5.9 Updates</p> <ul style="list-style-type: none"> • No changes to BRQs <p>Section 5.10 Updates</p> <ul style="list-style-type: none"> • Updated BRQs <ul style="list-style-type: none"> ○ EDAM-BRQ-16030, EDAM-BRQ-16100 • New BRQs <ul style="list-style-type: none"> ○ EDAM-BRQ-16010, EDAM-BRQ-16145, EDAM-BRQ-16150

 California ISO	Technology	Template Version:	6.8
		Document Version:	4-6 1.7
Extended Day Ahead Market Business Requirements Specification - Planning		Date Created:	1/21/2026

Date	Version	Description
		<p>Section 5.11 Updates</p> <ul style="list-style-type: none"> • Updated BRQs <ul style="list-style-type: none"> ○ EDAM-BRQ-17020, EDAM-BRQ-17040, EDAM-BRQ-17050, EDAM-BRQ-17070a, EDAM-BRQ-17080, EDAM-BRQ-17110, EDAM-BRQ-17120, EDAM-BRQ-17122, EDAM-BRQ-17210 <p>Section 5.12 Updates</p> <ul style="list-style-type: none"> • No changes to BRQs <p>Section 5.13 Updates</p> <ul style="list-style-type: none"> • Updated BRQs <ul style="list-style-type: none"> ○ EDAM-BRQ-19020, EDAM-BRQ-19090, EDAM-BRQ-19210, EDAM-BRQ-19293 • New BRQs <ul style="list-style-type: none"> ○ EDAM-IST-BRQ-19540, EDAM-IST-BRQ-19550, EDAM-TSR-BRQ-19617, EDAM-TSR-BRQ-19618, EDAM-TSR-BRQ-19620, EDAM-TSR-BRQ-19625, EDAM-TSR-BRQ-19626, EDAM-TSR-BRQ-19627, EDAM-TSR-BRQ-19630, EDAM-TSR-BRQ-19631, EDAM-TSR-BRQ-19632, EDAM-TSR-BRQ-19633, EDAM-TSR-BRQ-19635, EDAM-TSR-BRQ-19636, EDAM-TSR-BRQ-19637, EDAM-TSR-BRQ-19638, EDAM-TSR-BRQ-19640, EDAM-TSR-BRQ-19641, EDAM-TSR-BRQ-19642, EDAM-TSR-BRQ-19643 • Removed BRQs <ul style="list-style-type: none"> ○ EDAM-BRQ-19024 <p>Section 5.14 Updates</p> <ul style="list-style-type: none"> • Updated BRQs <ul style="list-style-type: none"> ○ EDAM-BRQ-20022, EDAM-BRQ-20023, EDAM-BRQ-20051, EDAM-BRQ-20054, EDAM-BRQ-20070, EDAM-BRQ-20080, EDAM-BRQ-20082, EDAM-BRQ-20156 • New BRQs <ul style="list-style-type: none"> ○ EDAM-BRQ-20157, EDAM-BRQ-20275, EDAM-TSR-BRQ-21005, EDAM-TSR-BRQ-21006 • Removed BRQs <ul style="list-style-type: none"> ○ EDAM-BRQ-20010, EDAM-BRQ-20011, EDAM-BRQ-20013, EDAM-BRQ-20024, EDAM-BRQ-20245 <p>Section 5.15 Updates</p> <ul style="list-style-type: none"> • No changes to BRQs <p>Section 5.16 Updates</p> <ul style="list-style-type: none"> • No changes to BRQs <p>Section 5.17 Updates</p> <ul style="list-style-type: none"> • Updated BRQs <ul style="list-style-type: none"> ○ EDAM-MSIM-24160 <p>Added Appendix A13: TSR Glossary of Terms</p>

 California ISO	Technology	Template Version:	6.8
		Document Version:	6.1.7
Extended Day Ahead Market Business Requirements Specification - Planning		Date Created:	1/21/2026

Date	Version	Description
8/5/2025	1.5	<p>Updates by Topic:</p> <ul style="list-style-type: none"> • New Section 5.4: Resource Adequacy eligible imports into the CAISO • New Section 5.14: Congestion Revenue Allocation • Inter-SC trade requirements removed from EDAM Day 1 scope (with IST in BRQ ID) • New requirements to define which SCs can schedule at GAP-TIEs • New requirements to support Nomogram activation (with DARA in BRQ ID) • New requirements to provide DAM reports to EDAM Entities (with DARA in BRQ ID) • Additional clarifications throughout document <p>Updates by Section/Individual Requirements:</p> <p>Section 5.1 Updates</p> <ul style="list-style-type: none"> • Updated BRQs <ul style="list-style-type: none"> ○ EDAM-BRQ-02083b, EDAM-BRQ-02085, EDAM-TSR-BRQ-02317 • New BRQs <ul style="list-style-type: none"> ○ EDAM-BRQ-02330, EDAM-BRQ-02345, EDAM-BRQ-02346a, EDAM-BRQ-02346b EDAM-BRQ-02350 • Removed BRQs <ul style="list-style-type: none"> ○ EDAM-IST-BRQ-02280 <p>Section 5.2 Updates</p> <ul style="list-style-type: none"> • Updated BRQs <ul style="list-style-type: none"> ○ EDAM-BRQ-04013a (previously 04013), EDAM-BRQ-04020a • New BRQs <ul style="list-style-type: none"> ○ EDAM-BRQ-04013b <p>Section 5.3 Updates</p> <ul style="list-style-type: none"> • Updated BRQs <ul style="list-style-type: none"> ○ EDAM-BRQ-05060, EDAM-BRQ-05070, EDAM-BRQ-05075 • New BRQs <ul style="list-style-type: none"> ○ EDAM-BRQ-05085 <p>Section 5.4: New Resource Adequacy Section</p> <ul style="list-style-type: none"> • New BRQs <ul style="list-style-type: none"> ○ EDAM-BRQ-07105, EDAM-BRQ-07106, EDAM-BRQ-07107, EDAM-BRQ-07110, EDAM-BRQ-07110, EDAM-BRQ-07111, EDAM-BRQ-07121, EDAM-BRQ-07122, EDAM-BRQ-07125, EDAM-BRQ-01730 <p>Section 5.5 Updates</p> <ul style="list-style-type: none"> • No changes to BRQs <p>Section 5.6 Updates</p> <ul style="list-style-type: none"> • Updated BRQs <ul style="list-style-type: none"> ○ EDAM-BRQ-11055a, EDAM-BRQ-11058, EDAM-BRQ-11058a, EDAM-TSR-BRQ-11141a, EDAM-TSR-BRQ-11144e, EDAM-TSR-BRQ-11145c, EDAM-TSR-BRQ-11155, EDAM-TSR-BRQ-11156

 California ISO	Technology	Template Version:	6.8
		Document Version:	6.1.7
Extended Day Ahead Market Business Requirements Specification - Planning		Date Created:	1/21/2026

Date	Version	Description
		<ul style="list-style-type: none"> • New BRQs <ul style="list-style-type: none"> ○ EDAM-BRQ-11190, EDAM-BRQ-11191, EDAM-BRQ-11195, EDAM-BRQ-13220, EDAM-BRQ-13225 • Removed BRQs <ul style="list-style-type: none"> ○ EDAM-11022, EDAM-BRQ-11222, EDAM-IST-BRQ-11400, EDAM-IST-BRQ-11410, EDAM-IST-BRQ-11420, EDAM-IST-BRQ-11430, EDAM-IST-BRQ-11440, EDAM-IST-BRQ-11450, EDAM-IST-BRQ-11460, EDAM-IST-BRQ-11470, EDAM-IST-BRQ-11480, EDAM-IST-BRQ-11490, EDAM-IST-BRQ-11500, EDAM-IST-BRQ-11510, EDAM-IST-BRQ-11520, EDAM-IST-BRQ-11530 <p>Section 5.7 Updates</p> <ul style="list-style-type: none"> • Updated BRQs <ul style="list-style-type: none"> ○ EDAM-BRQ-12150 • Removed BRQs <ul style="list-style-type: none"> ○ EDAM-BRQ-12030a <p>Section 5.8 Updates</p> <ul style="list-style-type: none"> • Updated BRQs <ul style="list-style-type: none"> ○ EDAM-BRQ-13025, EDAM-BRQ-13052, EDAM-BRQ-13052a, EDAM-BRQ-13054, EDAM-BRQ-13080, EDAM-BRQ-13095, EDAM-BRQ-13200 (changed from 13162) • New BRQs <ul style="list-style-type: none"> ○ EDAM-BRQ-13162, EDAM-DARA-BRQ-641, EDAM-DARA-BRQ-642 • Removed BRQs <ul style="list-style-type: none"> ○ EDAM-BRQ-13220 <p>Section 5.9 Updates</p> <ul style="list-style-type: none"> • Updated BRQs <ul style="list-style-type: none"> ○ EDAM-BRQ-14010 <p>Section 5.10 Updates</p> <ul style="list-style-type: none"> • Updated BRQs <ul style="list-style-type: none"> ○ EDAM-BRQ-15134 <p>Section 5.11 Updates</p> <ul style="list-style-type: none"> • Updated BRQs <ul style="list-style-type: none"> ○ EDAM-BRQ-16140 • New BRQs <ul style="list-style-type: none"> ○ EDAM-BRQ-16017. EDAM-BRQ-16018 • Removed BRQs <ul style="list-style-type: none"> ○ EDAM-BRQ-16016 <p>Section 5.12 Updates</p> <ul style="list-style-type: none"> • Updated BRQs <ul style="list-style-type: none"> ○ EDAM-BRQ-17070a

 California ISO	Technology	Template Version:	6.8
		Document Version:	6.1.7
Extended Day Ahead Market Business Requirements Specification - Planning		Date Created:	1/21/2026

Date	Version	Description
		<p>Section 5.13 Updates</p> <ul style="list-style-type: none"> • No changes to BRQs <p>Section 5.14 Updates: New Congestion revenue Allocation Section</p> <ul style="list-style-type: none"> • New BRQs <ul style="list-style-type: none"> ○ EDAM-CRA-BRQ-06030, EDAM-CRQ-BRQ-06032, EDAM-CRQ-BRQ-06031, EDAM-CRQ-BRQ-06030a, EDAM-CRQ-BRQ-06034, EDAM-CRQ-BRQ-06036, EDAM-CRQ-BRQ-06038, EDAM-CRQ-BRQ-06040, EDAM-CRQ-BRQ-06041, EDAM-CRQ-BRQ-06042, EDAM-CRQ-BRQ-06044, EDAM-CRQ-BRQ-06046, EDAM-CRQ-BRQ-06032, EDAM-CRQ-BRQ-06033, EDAM-CRQ-BRQ-06034, EDAM-CRQ-BRQ-06034a, EDAM-CRQ-BRQ-06034b, EDAM-CRQ-BRQ-06048, EDAM-CRQ-BRQ-19710, EDAM-CRQ-BRQ-19720, EDAM-CRQ-BRQ-19730, EDAM-CRQ-BRQ-19740, EDAM-CRQ-BRQ-19750, EDAM-CRQ-BRQ-19760, EDAM-CRQ-BRQ-19760a, EDAM-CRQ-BRQ-19770, EDAM-CRQ-BRQ-19770a, EDAM-CRQ-BRQ-19770b, EDAM-CRQ-BRQ-19780, EDAM-CRQ-BRQ-19790, EDAM-CRQ-BRQ-19790a, EDAM-CRQ-BRQ-20176b, EDAM-CRQ-BRQ-20277b <p>Section 5.15 Updates</p> <ul style="list-style-type: none"> • Updated BRQs <ul style="list-style-type: none"> ○ EDAM-BRQ-19175, EDAM-BRQ-19297, EDAM-BRQ-19310c, EDAM-TSR-BRQ-19643 • Removed BRQs <ul style="list-style-type: none"> ○ EDAM-IST-BRQ-19540, EDAM-IST-BRQ-19550 <p>Section 5.16 Updates</p> <ul style="list-style-type: none"> • New BRQs <ul style="list-style-type: none"> ○ EDAM-BRQ-20010, EDAM-BRQ-20011, EDAM-BRQ-20035, EDAM-BRQ-20070a, EDAM-BRQ-20070b, EDAM-BRQ-20070c, EDAM-BRQ-20082b, EDAM-BRQ-20105, EDAM-BRQ-20106, EDAM-BRQ-20120a, EDAM-BRQ-20146, EDAM-BRQ-20147, EDAM-DARA-BRQ-105, EDAM-DARA-BRQ-110 • Updated BRQs <ul style="list-style-type: none"> ○ EDAM-BRQ-20080, EDAM-BRQ-20082a (changed from 20082), EDAM-BRQ-20120, EDAM-BRQ-20145, EDAM-BRQ-20156 <p>Section 5.17 Updates</p> <ul style="list-style-type: none"> • New BRQs <ul style="list-style-type: none"> ○ EDAM-BRQ-20235, EDAM-CRA-BRQ-20276c <p>Section 5.18 Updates</p> <ul style="list-style-type: none"> • Updated BRQs <ul style="list-style-type: none"> ○ EDAM-BRQ-22050 • New BRQs <ul style="list-style-type: none"> ○ EDAM-DARA-BRQ-610, EDAM-DARA-BRQ-620, EDAM-DARA-BRQ-640 <p>Section 5.19 Updates</p>

 California ISO	Technology	Template Version:	6.8
		Document Version:	6.1.7
Extended Day Ahead Market Business Requirements Specification - Planning		Date Created:	1/21/2026

Date	Version	Description
		<ul style="list-style-type: none"> • Updated BRQs <ul style="list-style-type: none"> ○ EDAM-MSIM-BRQ-24160 • Removed BRQs <ul style="list-style-type: none"> ○ EDAM-MSIM-BRQ-24080
1/20/2026	1.6	<p>Updates by Topic:</p> <ul style="list-style-type: none"> • Updates to Mirror System Resources and Auto-Mirroring functionality • Updates to TSR and Transfer Location naming convention • Inter-SC Trading BRQs re-added to BRS (with IST in BRQ ID) • Updates to Resource Adequacy eligible imports into the CAISO scope and requirements, including addition of MISIM • New requirements to allow EDAM Entities to access bid data for resources in their BAA • New requirements to detail HASP participation (with HASP in BRQ ID) • Updates to calculation and application of losses in the GHG Model • New requirements to expand GHG Regulation Area definition • Settlements to provide UIE load price reference data • Additional reports to be made available to EDAM Entity for resource schedule and IST trade data • Removal of ETSR/TSR shadow price reporting from OASIS • DA-RSE and Congestion Revenue data to be reported to FERC • WebOMS UI enhancement to display BAA • Updates to impacted systems in MSIM scenarios • Addition of Congestion Revenue Allocation MISIM scenario • Additional clarifications throughout document <p>Updates by Section/Individual Requirements:</p> <p>Section 5.1 Updates</p> <ul style="list-style-type: none"> • Updated BRQs <ul style="list-style-type: none"> ○ EDAM-BRQ-02083a, EDAM-BRQ-02083b, EDAM-TSR-BRQ-02051d, EDAM-TSR-BRQ-02051e • New BRQs <ul style="list-style-type: none"> ○ EDAM-IST-BRQ-02280, EDAM-BRQ-02355 <p>Section 5.2 Updates</p> <ul style="list-style-type: none"> • Updated BRQs <ul style="list-style-type: none"> ○ EDAM-BRQ-04014, EDAM-BRQ-04021 <p>Section 5.3 Updates</p> <ul style="list-style-type: none"> • Updated BRQs <ul style="list-style-type: none"> ○ EDAM-BRQ-05020 <p>Section 5.4: New Resource Adequacy Section (entire section updated; requirements have been rewritten to improve clarity and facilitate clear red-lines, with some new and some existing BRQ IDs)</p> <ul style="list-style-type: none"> • New BRQs

 California ISO	Technology	Template Version:	6.8
		Document Version:	6.1.7 1.7
Extended Day Ahead Market Business Requirements Specification - Planning		Date Created:	1/21/2026

Date	Version	Description
		<ul style="list-style-type: none"> ○ EDAM-BRQ-07100, EDAM-BRQ-07100a, EDAM-BRQ-07100b EDAM-BRQ-07100d, EDAM-BRQ-07103, EDAM-BRQ-07103a, EDAM-BRQ-07103b, EDAM-BRQ-07104, EDAM-BRQ-07104a, EDAM-BRQ-07105, EDAM-BRQ-07105a, EDAM-BRQ-07106, EDAM-BRQ-07106a, EDAM-BRQ-07110, EDAM-BRQ-07110a, EDAM-BRQ-0711a, EDAM-BRQ-0711b, EDAM-BRQ-07112e, EDAM-BRQ-07113, EDAM-BRQ-07115, EDAM-BRQ-07116, EDAM-BRQ-07125, EDAM-BRQ-07125a, EDAM-BRQ-01735, EDAM-BRQ-07137 <p>Section 5.5 Updates</p> <ul style="list-style-type: none"> • No changes to BRQs <p>Section 5.6 Updates</p> <ul style="list-style-type: none"> • Updated BRQs <ul style="list-style-type: none"> ○ EDAM-BRQ-11290, EDAM-TSR-BRQ-11141a, EDAM-TSR-BRQ-11144b, EDAM-TSR-BRQ-11144e, EDAM-TSR-BRQ-11144f, EDAM-TSR-BRQ-11145a, EDAM-TSR-BRQ-11146a, EDAM-TSR-BRQ-11155 • New BRQs <ul style="list-style-type: none"> ○ EDAM-BRQ-11295a, EDAM-BRQ-11295b, EDAM-IST-BRQ-11400, EDAM-IST-BRQ-11410, EDAM-IST-BRQ-11420, EDAM-IST-BRQ-11430, EDAM-IST-BRQ-11440, EDAM-IST-BRQ-11450, EDAM-IST-BRQ-11460, EDAM-IST-BRQ-11470, EDAM-IST-BRQ-11480, EDAM-IST-BRQ-11490, EDAM-IST-BRQ-11500, EDAM-IST-BRQ-11510, EDAM-IST-BRQ-11520, EDAM-IST-BRQ-11530 • Removed BRQs <ul style="list-style-type: none"> ○ EDAM-BRQ-11058a <p>Section 5.7 Updates</p> <ul style="list-style-type: none"> • No changes to BRQs <p>Section 5.8 Updates</p> <ul style="list-style-type: none"> • Updated BRQs <ul style="list-style-type: none"> ○ EDAM-BRQ-13040, EDAM-BRQ-13052b, EDAM-BRQ-13200, EDAM-TSR-BRQ-12046, EDAM-TSR-BRQ-12047 <p>Section 5.9 Updates</p> <ul style="list-style-type: none"> • No changes to BRQs <p>Section 5.10 Updates</p> <ul style="list-style-type: none"> • Updated BRQs <ul style="list-style-type: none"> ○ EDAM-BRQ-15110 • New BRQs <ul style="list-style-type: none"> ○ EDAM-BRQ-15220 <p>Section 5.11 Updates</p> <ul style="list-style-type: none"> • Updated BRQs <ul style="list-style-type: none"> ○ EDAM-BRQ-16010

 California ISO	Technology	Template Version:	6.8
		Document Version:	6.1.7
Extended Day Ahead Market Business Requirements Specification - Planning		Date Created:	1/21/2026

Date	Version	Description
		<ul style="list-style-type: none"> • New BRQs <ul style="list-style-type: none"> ○ EDAM-HASP-BRQ-16187, EDAM-HASP-BRQ-16189, EDAM-HASP-BRQ-16190, EDAM-HASP-BRQ-16190a, EDAM-BRQ-16195, EDAM-BRQ-16200 Section 5.12 Updates • Updated BRQs <ul style="list-style-type: none"> ○ EDAM-BRQ-17030, EDAM-BRQ-17070a • New BRQs <ul style="list-style-type: none"> ○ EDAM-BRQ-17240, EDAM-BRQ-17241, EDAM-BRQ-17246, EDAM-BRQ-17248, EDAM-BRQ-17249, EDAM-BRQ-17251, EDAM-BRQ-17255 Section 5.13 Updates • No changes to BRQs Section 5.14 Updates • Updated BRQs <ul style="list-style-type: none"> ○ EDAM-CRA-BRQ-06032a (changed from EDAM-CRA-BRQ-06032), EDAM-CRA-BRQ-06035 (changed from EDAM-CRA-BRQ-06034) Section 5.15 Updates • New BRQs <ul style="list-style-type: none"> ○ EDAM-IST-BRQ-19540, EDAM-IST-BRQ-19550, EDAM-BRQ-18915 Section 5.16 Updates • Updated BRQs <ul style="list-style-type: none"> ○ EDAM-BRQ-20020, EDAM-BRQ-20023, EDAM-BRQ-20030, EDAM-BRQ-20031, EDAM-BRQ-20054, EDAM-BRQ-20110, EDAM-BRQ-20120, EDAM-BRQ-20145, EDAM-BRQ-20146, EDAM-BRQ-20147 • New BRQs <ul style="list-style-type: none"> ○ EDAM-BRQ-18910, EDAM-BRQ-18911, EDAM-IST-BRQ-20540, EDAM-BRQ-20159 • Removed BRQs <ul style="list-style-type: none"> ○ EDAM-BRQ-20070 Section 5.17 Updates • New BRQs <ul style="list-style-type: none"> ○ EDAM-BRQ-18908f, EDAM-CRA-BRQ-20276c Section 5.18 Updates • New BRQs <ul style="list-style-type: none"> ○ EDAM-BRQ-22048b Section 5.19 Updates • Updated BRQs <ul style="list-style-type: none"> ○ EDAM-MSIM-BRQ-24040, EDAM-MISM-BRQ-24060, EDAM-MSIM-BRQ-24100, EDAM-MSIM-BRQ-24120, EDAM-MSIM-BRQ-24160,

 California ISO	Technology	Template Version:	6.8
		Document Version:	6.1.7 1.7
Extended Day Ahead Market Business Requirements Specification - Planning		Date Created:	1/21/2026

Date	Version	Description
		<ul style="list-style-type: none"> • New BRQs <ul style="list-style-type: none"> ○ EDAM-MSIM-BRQ-24245, EDAM-CRA-MSIM-BRQ-24250
<u>3/26/2026</u>	<u>1.7</u>	<p><u>Updates by Topic:</u></p> <ul style="list-style-type: none"> • <u>Removal of GAP/GAP-TIE BRQs that are not included in May 1 implementation</u> • <u>Removal of Inter-SC Trade requirements (with IST in ID): not included for May 1 implementation, this scope will be tracked as part of EDAM Enhancements Initiative</u> • <u>New requirements to allow EDAM Entity access to meter data in their BA</u> • <u>New requirements to allow EDAM Entity to designate SC to submit AS requirements</u> • <u>New requirements to differentiate between constraint types submitted to Path Limit Calculator (PLC)</u> • <u>New requirements to report settlements calculated market balanced contract data</u> • <u>Updates to Market Simulation scenarios and impacted systems</u> • <u>Requirement type updates throughout document (e.g. changed from Core to Process)</u> • <u>Requirement clarifications throughout document</u> <p><u>Updates by Section/Individual Requirements:</u></p> <p><u>Section 5.1 Updates</u></p> <ul style="list-style-type: none"> • <u>Updated BRQs</u> <ul style="list-style-type: none"> ○ <u>EDAM-BRQ-02083, EDAM-BRQ-02083a, EDAM-BRQ-02083b, EDAM-BRQ-02087, EDAM-TSR-BRQ-02051a, EDAM-TSR-BRQ-02051f, EDAM-TSR-BRQ-02316, EDAM-TSR-BRQ-02318, EDAM-BRQ-02345</u> • <u>Removed BRQs</u> <ul style="list-style-type: none"> ○ <u>EDAM-BRQ-02085, EDAM-BRQ-02086, EDAM-BRQ-02088, EDAM-BRQ-02089, EDAM-BRQ-02089a, EDAM-BRQ-02100 (redundant with other TSR BRQs), EDAM-BRQ-02346a, EDAM-BRQ-02346b, EDAM-IST-BRQ-02280, EDAM-BRQ-02355</u> <p><u>Section 5.2 Updates</u></p> <ul style="list-style-type: none"> • <u>Updated BRQs</u> <ul style="list-style-type: none"> ○ <u>EDAM-BRQ-04052, EDAM-BRQ-04052a, EDAM-BRQ-04053</u> <p><u>Section 5.3 Updates</u></p> <ul style="list-style-type: none"> • <u>No changes to BRQs</u> <p><u>Section 5.4 Updates</u></p> <ul style="list-style-type: none"> • <u>No changes to BRQs</u> <p><u>Section 5.5 Updates</u></p> <ul style="list-style-type: none"> • <u>No changes to BRQs</u> <p><u>Section 5.6 Updates</u></p> <ul style="list-style-type: none"> • <u>Updated BRQs</u> <ul style="list-style-type: none"> ○ <u>EDAM-BRQ-11130</u> • <u>New BRQs</u> <ul style="list-style-type: none"> ○ <u>EDAM-BRQ-13230</u>

 California ISO	Technology	Template Version:	6.8
		Document Version:	4.61.7
Extended Day Ahead Market Business Requirements Specification - Planning		Date Created:	1/21/2026

Date	Version	Description
		<ul style="list-style-type: none"> • <u>Removed BRQs</u> <ul style="list-style-type: none"> ○ <u>EDAM-IST-BRQ-11400, EDAM-IST-BRQ-11410, EDAM-IST-BRQ-11420, EDAM-IST-BRQ-11430, EDAM-IST-BRQ-11440, EDAM-IST-BRQ-11450, EDAM-IST-BRQ-11460, EDAM-IST-BRQ-11470, EDAM-IST-BRQ-11480, EDAM-IST-BRQ-11490, EDAM-IST-BRQ-11500, EDAM-IST-BRQ-11510, EDAM-IST-BRQ-11520, EDAM-IST-BRQ-11530</u> • <u>Section 5.7 Updates</u> • <u>No changes to BRQs</u> • <u>Section 5.8 Updates</u> • <u>No changes to BRQs</u> • <u>Section 5.9 Updates</u> • <u>No changes to BRQs</u> • <u>Section 5.10 Updates</u> • <u>No changes to BRQs</u> • <u>Section 5.11 Updates</u> • <u>Updated BRQs</u> <ul style="list-style-type: none"> ○ <u>EDAM-BRQ-16017, EDAM-BRQ-16102</u> • <u>Section 5.12 Updates</u> • <u>Updated BRQs</u> <ul style="list-style-type: none"> ○ <u>EDAM-BRQ-17241</u> • <u>Section 5.13 Updates</u> • <u>No changes to BRQs</u> • <u>Section 5.14 Updates</u> • <u>No changes to BRQs</u> • <u>Section 5.15 Updates</u> • <u>Updated BRQs</u> <ul style="list-style-type: none"> ○ <u>EDAM-BRQ-19175, EDAM-BRQ-19364, EDAM-BRQ-19365</u> • <u>New BRQs</u> <ul style="list-style-type: none"> ○ <u>EDAM-BRQ-18930, EDAM-BRQ-18932, EDAM-BRQ-18935</u> • <u>Removed BRQs</u> <ul style="list-style-type: none"> ○ <u>EDAM-IST-BRQ-19540, EDAM-IST-BRQ-19550</u> • <u>Section 5.16 Updates</u> • <u>Updated BRQs</u> <ul style="list-style-type: none"> ○ <u>EDAM-BRQ-20070b, EDAM-BRQ-20090, EDAM-BRQ-20159</u> • <u>New BRQs</u> <ul style="list-style-type: none"> ○ <u>EDAM-BRQ-20546, EDAM-BRQ-20288</u>

 California ISO	Technology	Template Version:	6.8
		Document Version:	4.6 1.7
Extended Day Ahead Market Business Requirements Specification - Planning		Date Created:	1/21/2026

Date	Version	Description
		<ul style="list-style-type: none"> • <u>Removed BRQs</u> <ul style="list-style-type: none"> ○ <u>EDAM-IST-BRQ-20540</u> • <u>Section 5.17 Updates</u> • <u>No changes to BRQs</u> • <u>Section 5.18 Updates</u> • <u>New BRQs</u> <ul style="list-style-type: none"> ○ <u>EDAM-BRQ-09030 (PLC)</u> • <u>Removed BRQs</u> <ul style="list-style-type: none"> ○ <u>EDAM-BRQ-22048b</u> • <u>Section 5.19 Updates</u> • <u>Updated BRQs</u> <ul style="list-style-type: none"> ○ <u>EDAM-MSIM-BRQ-24020, EDAM-MSIM-BRQ-24040, EDAM-MSIM-BRQ-24060, EDAM-MSIM-BRQ-24100, EDAM-MSIM-BRQ-24120, EDAM-MSIM-BRQ-24140, EDAM-MSIM-BRQ-24245</u>

Disclaimer and Understanding

All information contained in this draft Business Requirements Specification (BRS) as provided by the California Independent System Operator Corporation (ISO) is prepared for discussion and information purposes only. The draft BRS is provided “as is” without representation or warranty of any kind, including, without limitation, a representation or warranty as to accuracy, completeness, or appropriateness for any particular purpose. The draft BRS shall be revised as the development and review of the business requirements progresses. The ISO assumes no responsibility for the consequences of any errors or omissions. The ISO may revise or withdraw all or part of this information at any time at its discretion without notice.

 California ISO	Technology	Template Version:	6.8
		Document Version:	6.1.7 1.7
Extended Day Ahead Market Business Requirements Specification - Planning		Date Created:	1/21/2026

Table of Contents

1. Introduction24

 1.1 Purpose.....24

 1.2 Conventions.....24

 1.3 Scope.....24

 1.4 Acronym and Terms Definitions.....26

 1.5 Glossary.....26

2. Intellectual Property Ownership.....27

 2.1 Checklist.....27

3. Details of Business Need/Problem.....28

 3.1 Description.....28

4. Business Impacts.....29

 4.1 Business Practice Manuals (BPM).....29

 4.2 Other.....29

5. Business Requirements.....30

 5.1 Business Process: Manage Model & Contract Implementation & Full Network Model (Master File)30

 5.1.1 Business Requirements.....30

 5.2 Business Process: Manage Forecasting (ALFS)51

 5.2.1 Business Requirements.....51

 5.3 Business Process: Manage BAA Requirement Calculation56

 5.3.1 Business Requirements.....56

 5.4 Business Process: Manage Resource Adequacy60

 5.4.1 Business Requirements.....60

 5.5 Business Process: Manage Default Energy Bids.....68

 5.5.1 Business Requirements.....68

 5.6 Business Process: Manage Bid Submission and TSR Submission (SIBR, TSR submission).....71

 5.6.1 Business Requirements.....71

 5.7 Business Process: Manage DAM Resource Sufficiency Evaluation (DA-RSE).....102

 5.7.1 Business Requirements.....102

 5.8 Business Process: Manage DAM (MPM, IFM).....110

 California ISO	Technology	Template Version:	6.8
		Document Version:	6.1.7
Extended Day Ahead Market Business Requirements Specification - Planning		Date Created:	1/21/2026

5.8.1 Business Requirements.....	110
5.9 Business Process: Manage RUC (RUC, DAM TD+X).....	124
5.9.1 Business Requirements.....	124
5.10 Business Process: Manage Tagging DAM Schedules and resupply (RTSI, ITS, SIBR).....	129
5.10.1 Business Requirements.....	129
5.11 Business Process: Manage RTM (RT-RSE, RTM).....	134
5.11.1 Business Requirements.....	134
5.12 Business Process: Manage GHG in DAM & RTM (GHG pass, GHG model in DAM and RTM) .	148
5.12.1 Business Requirements.....	148
5.13 Business Process: Manage Market Quality, Validation and Price Correction.....	157
5.13.1 Business Requirements.....	157
5.14 Business Process: Manage Congestion Revenue Allocation.....	160
5.14.1 Business Requirements.....	161
5.15 Business Process: Manage Billing and Settlements (Settlements).....	172
5.15.1 Business Requirements.....	172
5.16 Business Process: Manage Market Reporting (CMRI, OASIS).....	217
5.16.1 Business Requirements.....	217
5.17 Manage FERC Reporting.....	231
5.17.1 Business Requirements.....	231
5.18 Manage Outages (WebOMS) and Constraints (PLC).....	233
5.18.1 Business Requirements.....	233
5.19 Business Process: Market/Business Simulation.....	237
5.19.1 Business Requirements.....	238
Appendices.....	244
Appendix A: Formulas, Calculation Details, and Examples.....	244
Appendix A0: Acronym Definition.....	244
Appendix A1.....	259
Appendix A2.....	259
Appendix A3.....	259
Appendix A4.....	259
Appendix A5.....	259
Appendix A6.....	259

 California ISO	Technology	Template Version:	6.8
		Document Version:	4.6 1.7
Extended Day Ahead Market Business Requirements Specification - Planning		Date Created:	1/21/2026

Appendix A7: Transmission right (ETC/TOR/OATT) sales examples 260
Appendix A8: EDAM Access Charge Illustrative Example 263
Appendix A9: Business Flow Diagrams 273
Appendix A10 275
Appendix A11 275
Appendix A12 275
Appendix A13: TSR Glossary of Terms 276

 California ISO	Technology	Template Version:	6.8
		Document Version:	6.1.7
Extended Day Ahead Market Business Requirements Specification - Planning		Date Created:	1/21/2026

1. Introduction

1.1 Purpose

The purpose of this document is to capture and record a description of what the Users and Business Stakeholders of the project wish to obtain, by providing high level business requirements. This document establishes the basis for the agreement between the initiators and implementers of the project. The information in this document serves as input to determine the scope of projects and all Business Process Modeling and System Requirements Specifications (SRS) efforts.

Business requirements are what must be delivered to provide value for the Users and Business Stakeholders. Systems, software, and processes are the ways (how) to deliver, satisfy, or meet the business requirements (what).

1.2 Conventions

None

1.3 Scope

Pre-Market Activities

- Extended Day-Ahead Market (EDAM) participating entity contracting
- DA Resource Sufficiency Evaluation (RSE):
 - Optimally determine resource sufficiency for each Balancing Authority Area (BAA) ahead of Day-Ahead Market (DAM) run
 - Report the deficiency of Energy, Imbalance Reserves Up/Down (IRU/IRD), and Ancillary Services (AS)
 - Evaluate RSE before DAM closes for each EDAM BAA
 - Tiered failure consequences with tolerance band and surcharge
- Transmission Commitment (RSE eligible, transmission right, unsold Available Transfer Capacity)
 - Consume from each BAA the availability of transmission internally and across transfer points between EDAM BAAs before market runs
 - Consume transfer limits between EDAM BAAs that parties are using to support RSE showing
 - Register and respect the exercise of existing transmission rights
 - Register and consume the transfer capacity for unsold Firm Available Transfer Capacity (ATC)

DA Market Processes

- Integrated Forward Market (IFM)
 - Market Power Mitigation (MPM) for Energy and IRU for EDAM BAAs – extend DAME
 - Identify transfers for energy, IR, and Reliability Capacity (RC) across EDAM BAAs
 - Procure IRU/IRD across EDAM footprint – extend DAME

 California ISO	Technology	Template Version:	6.8
		Document Version:	6.1.7
Extended Day Ahead Market Business Requirements Specification - Planning		Date Created:	1/21/2026

- EDAM entity option to activate hourly net transfer out constraint
 - Price formation for each EDAM BAA, with BAA energy components MEC
- Residual Unit Commitment (RUC)
 - Any offer into RUC must also be offered into IFM (VERs exempted)
 - Include MPM for reliability upper capacity – extend DAME
 - Procure RCU/RCD across EDAM footprint – extend DAME
- Convergence Bidding
 - Retain convergence bidding as it is today in ISO
 - Optional for EDAM BAAs for first two years of participation in EDAM
- External Resource Participation:
 - For ISO – continue to allow inertia bids from non-EDAM BAAs
 - Allow EDAM BAAs to submit self-schedules or qualified network resource economic bids at inertias from non-EDAM BAAs

Greenhouse Gas (GHG) Accounting and Design

- Model multiple GHG regulation areas and boundaries
- Build a GHG reference pass before MPM/IFM without GHG bids to build resource GHG reference point
- Extend resource specific GHG attribution model used in WEIM to EDAM, utilize the GHG reference point
- Limit GHG attribution to hourly net export transfers or to zero if there is a net import transfer, allow Resource Adequacy (RA)/contract import

Post-DA Market Processes

- Report Tagged DAM awards after DAM, publish tagging report around 3 hours after EDAM. Require tagged DAM schedule or resupply by TH-5h to be counted in the pooled WEIM RSE

Real Time Market

- Resource with DAM awards subject to must offer in RTM
- The EDAM BAAs that tagged and/or resupplied will conduct pooled RTM-RSE
- Align WEIM GHG model with EDAM GHG model
- Price formation for each WEIM BAA with BAA energy components MEC

Settlements

- Collect transfer revenue for energy transfer, imbalance reserve (IRU/IRD) transfer and Reliability capacity (RCU/RCD) transfer
- Allocate transfer revenue to EDAM BAA or transmission rights owner
 - ISO BAA sub-allocation to be determined in CAISO EDAM Participation Rules Initiative
- Allocate congestion revenue to the BAA which transmission constraint modeled
- Settlements and allocation for energy, IRU/IRD, RCU/RCD
- DAM Settlements for GHG
- IFM RSE failure Administrative surcharge settlements and allocation
- IFM Bid cost recovery (BCR) and RUC/RTM BCR
- EDAM BAAs use DAM schedule (instead of base schedule) as the reference point to calculate the imbalance energy

 California ISO	Technology	Template Version:	6.8
		Document Version:	4.6 1.7
Extended Day Ahead Market Business Requirements Specification - Planning		Date Created:	1/21/2026

- RTM deviation Settlements for Energy/GHG/FRP/TSR
- Transfer Revenue Recovery Settlements
- EDAM administrative fees

1.4 Acronym and Terms Definitions

Acronyms definitions are listed in [Appendix A0](#)

1.5 Glossary

Refer to the [CAISO Glossary](#)

 California ISO	Technology	Template Version:	6.8
		Document Version:	4.6 1.7
Extended Day Ahead Market Business Requirements Specification - Planning		Date Created:	1/21/2026

2. Intellectual Property Ownership

2.1 Checklist

Intellectual Property covers a broad array of information and materials, including written works, computer programs, software, business manuals, processes, symbols, logos, and other work products. Determining ownership of Intellectual Property is very important in preserving the rights of the California ISO, and helps to avoid Intellectual Property infringement issues.

All information in this document is the Intellectual Property (copyright, trademark, patent, and/or trade secret) of the California ISO.

 California ISO	Technology	Template Version:	6.8
		Document Version:	6.1.7 1.7
Extended Day Ahead Market Business Requirements Specification - Planning		Date Created:	1/21/2026

3. Details of Business Need/Problem

3.1 Description

Business Opportunity/Problem Statement:	
What:	<p>The purpose of this initiative is to create a comprehensive extended day-ahead market that extends over multiple balancing authority areas (BAAs) participating in the WEIM. The EDAM will support voluntary entry, exit, and resource participation in the regional market. The EDAM market design is consistent with the ISO’s commitment to fiscal responsibility in structuring an equitable rate design for implementation and EDAM fees, resulting in fair and reasonable rates for its market participants. The market is designed to ensure confidence in market transfers.</p> <ul style="list-style-type: none"> • The EDAM design leverages existing features of the ISO day-ahead market that are common in other day-ahead markets across the country. The design also considers enhancements proposed in contemporaneous stakeholder initiatives, which will harness flexibility across the larger footprint by incorporating an imbalance reserve product, and that will enhance price formation.
Why do we have this opportunity/problem:	<p>EDAM is a voluntary day-ahead electricity market with the potential to deliver significant economic, environmental, and reliability benefits for participants across the West. EDAM will more efficiently and effectively integrate renewable resources and address the significant operational challenges presented by a rapidly changing resource mix, emerging technologies, and the impacts of climate change. EDAM will enable procurement of robust supply and flexible capacity that will position EDAM participants to effectively address changes in conditions from day-ahead to real-time, improving their response to potential reliability challenges. EDAM builds upon the proven ability of the Western Energy Imbalance Market (WEIM) to increase regional coordination, support state policy goals, and cost effectively meet demand.</p>

 California ISO	Technology	Template Version:	6.8
		Document Version:	6.8 1.7
Extended Day Ahead Market Business Requirements Specification - Planning		Date Created:	1/21/2026

4. Business Impacts

4.1 Business Practice Manuals (BPM)

BPM	Description of Impact(s)
Definitions and Acronyms	Yes-new definitions and acronyms as outlined in Tariff Appendix A
Energy Imbalance Market	Yes, details defined in Tariff and requirements
Extended Day Ahead Market	Yes, new BPM-details defined in Tariff and requirements
Market Instruments	Yes-details defined in requirements
Market Operations	Yes-details defined in requirements
Settlements and Billing	Yes-details defined in requirements
Reliability Requirements	Yes-RA Import obligation reassignment rules- details defined in requirements

4.2 Other

Impact	Description (optional)
Market Simulation	Yes
Market Participant Impact	Yes
External Bid Publication	Yes
Customer Readiness Impact	
<ul style="list-style-type: none"> • External Communication Needed 	Yes
<ul style="list-style-type: none"> • External Onboarding and Maintenance 	Yes
<ul style="list-style-type: none"> • External Training 	Yes
<ul style="list-style-type: none"> • External Computer Based Training 	Yes
Policy Initiative	Yes

 California ISO	Technology	Template Version:	6.8
		Document Version:	6.1.7
Extended Day Ahead Market Business Requirements Specification - Planning		Date Created:	1/21/2026

5. Business Requirements

The sections below describe the business processes and the associated business requirements involved in the project. These may represent high-level functional, non-functional, reporting, and/or infrastructure requirements. These business requirements directly relate to the high-level scope items determined for the project.

5.1 Business Process: Manage Model & Contract Implementation & Full Network Model (Master File)

- Define BAA with EDAM participation and activate date
- Define EDAM entity SC and EDAM resource SC—same for DAM and RTM
- Define EDAM internal and external resources, market product eligibility, and RSE flag
- Define DA transfer resources paired TSRs: TSR Type 1, TSR Type 2, TSR Type 3, and TSR Type 4
- Define Transfer Location
- Define EDAM BAA options/eligibilities: CB
- EDAM Entities Sign Attestation for Non-Participating DR Schedules Submission
- Define EDAM Entity election for Demand Response (DR) Inclusion Flag
- STF Notification of Changes to DR Inclusion Flag on EDAM Entity
- Define North/South DGAPs for scheduled resources with unknown location—SP and super DGAP association
- Define GHG regulation areas and resource association
- Define GHG regulation area and branch association in EMMS
- Define GMC rate for EDAM
- Define EDAM load and VER resource type forecast election: ISO or self-provided
- Define EDAM BAA CF and RM for net transfer out constraint
- Define Apnode for Imbalance Demand Hub for each EDAM BAA

5.1.1 Business Requirements

ID#	Business Feature	Requirement Type	Potential Application(s) Impacted
EDAM-BRQ-02010	Define EDAM Entity and EDAM entity SC <ul style="list-style-type: none"> • Register EDAM entity <ul style="list-style-type: none"> ○ Only WEIM entity can choose to participate in the EDAM 	Core	Master File

 California ISO	Technology	Template Version:	6.8
		Document Version:	6.1.7
Extended Day Ahead Market Business Requirements Specification - Planning		Date Created:	1/21/2026

ID#	Business Feature	Requirement Type	Potential Application(s) Impacted
	<ul style="list-style-type: none"> ▪ WEIM entity can continue to participate solely in the WEIM ○ New entity can join the WEIM and EDAM simultaneously ○ An entity exiting EDAM (with 6-month notice) can continue to participate in the WEIM • EDAM entity SC shall have the same SCID as in WEIM <ul style="list-style-type: none"> ○ EDAM entity SC represents EDAM entity ○ EDAM entity SC may represent a market participant other than an EDAM entity ○ EDAM entity SC may or may not be the SC for a market resource unless it is a government entity or gen-only BAA ○ Expanding current WEIM entity SC functionality—reclassify SCID to denote just WEIM or WEIM and EDAM 		
EDAM-BRQ-02020	<p>Define EDAM BAA participation and date:</p> <ul style="list-style-type: none"> • Define BAA with EDAM participation flag • Define activate date <ul style="list-style-type: none"> ○ Date must be not less than 6 months and not more than 24 months after the effective date of the EDAM Entity Implementation Agreement ○ The EDAM Entity may request a date change <p>Note: The participation flag is defined in DAME-BRQ-01200 also to accommodate EDAM participation</p>	Core	Master File
EDAM-BRQ-02030	<p>Define EDAM BAA elections for convergence bidding (CB)</p> <ul style="list-style-type: none"> • Define EDAM BAA convergence bidding (CB) activation date <ul style="list-style-type: none"> ○ CAISO CB shall remain activated – no change ○ EDAM BAA can elect to activate CB at the time of joining EDAM, or elect the first two-year transitional period* without convergence bidding • Registered location, position limit, and nodal constraint will be applicable for the EDAM BAAs that elect CB, in the same manner as CAISO <p>*Note: For BA that do not elect to turn on CB when joining EDAM, CB is NOT automatically activated after 2 years, rather, after two years of EDAM operation, Policy will make a determination regarding when and how to enable CB across the entire EDAM footprint</p>	Core	Master File

 California ISO	Technology	Template Version:	6.8
		Document Version:	6.1.7
Extended Day Ahead Market Business Requirements Specification - Planning		Date Created:	1/21/2026

ID#	Business Feature	Requirement Type	Potential Application(s) Impacted
EDAM-BRQ-02040	<p>Define EDAM BAA load and VER forecast options: ISO forecast or self-provide</p> <ul style="list-style-type: none"> • Define BAA option for load forecast: ISO-provided or self-provided—selection shall apply to both DAM and RTM • Define BAA option for VER resource or resource type forecast: ISO-provided or self-provided—selection shall apply to both DAM and RTM • Define all Hybrid Resources and the VER component forecast to be the same as the VER resource election 	Core	Master File
EDAM-BRQ-02041	<p>EDAM Entities Sign Attestation for Non-Participating DR Schedules Submission (refer to RSEE1-1060-BRQ-01020)</p> <p>Each EDAM Entity that plans to utilize a DR program shall sign an attestation that adjustments made to the demand forecast used by the RSE (via submission of Non-Participating DR Schedules) corresponds to expected increases or reductions in demand provided by their programs.</p> <p>Note: EDAM Entity by default is WEIM Entity too and all rules applicable to WEIM RSEE requirements shall be applicable to the EDAM Entities.</p>	Process	N/A
EDAM-BRQ-02042	<p>Define EDAM Entity election for Demand Response (DR) Inclusion Flag (refer to RSEE1-1060-BRQ-01040)</p> <ul style="list-style-type: none"> • Define Demand Response (DR) inclusion flag for including non-participating DR for load adjustment in RSE: <ul style="list-style-type: none"> ○ One flag per Entity • Where Entity is either: <ul style="list-style-type: none"> ○ WEIM-only Entity (existing) ○ EDAM Entity • That flag shall be enabled for an Entity, only if it has signed attestation stating that adjustments made to the demand forecast used by the DA/RT RSE correspond to expected increases or reductions (non-zero values) in demand provided by their programs. <p>Notes</p>	Core	Master File

 California ISO	Technology	Template Version:	6.8
		Document Version:	6.1.7
Extended Day Ahead Market Business Requirements Specification - Planning		Date Created:	1/21/2026

ID#	Business Feature	Requirement Type	Potential Application(s) Impacted
	<ul style="list-style-type: none"> If this flag is enabled for an Entity, it shall allow that entity to submit Non-Participating DR Schedules. This requires EDAM Entity's attestation. CAISO BAA flag is assumed to be always enabled. EDAM Entity by default is WEIM Entity too and all rules applicable to WEIM RSEE requirements shall be applicable to the EDAM Entities. EDAM Entity type is tracked via existing MF EDAM Participation Flag. 		
EDAM-BRQ-02044	<p>Define EDAM BAA Assistance Energy Transfer (AET) for WEIM</p> <ul style="list-style-type: none"> Allow EDAM BAA to elect WEIM AET <ul style="list-style-type: none"> Allow EDAM BAA election for AET option-in/out. <p>Note: In RTM if pooled EDAM BAAs fail the RTM-RSE, form two sub-pools: the sub-pool of BAA that elected AET, and sub-pool of BAAs that elected non-AET</p> <p>EDAM BAAs will be able to elect AET opt-in/out in RTM regardless of the outcome of RSE test for them in DAM (given they are WEIM BAAs in RTM).</p>	Existing RSEE2	Master File
EDAM-BRQ-02050	<p>Define EDAM resource scheduling coordinator (SC)</p> <ul style="list-style-type: none"> SC for WEIM and EDAM shall be the same (i.e. supply resources in both WEIM and EDAM shall have the same SC) SC for load resource for LSE in EDAM BAA to submit load bids and self-schedule for ELAP, for CLAP if applicable, similar as current DAM configuration to support ISO DLAP, CLAP SC for convergence bidding for EDAM BAA opt-in CB, no change as ISO <p>Note: SC must enter into a SC agreement</p>	Process	Master File
EDAM-BRQ-02051	<p>Define SC for DA TSR</p> <ul style="list-style-type: none"> Entity SC for intertie resource, transfer resource (TSR) in EDAM and WEIM (ex: DA TSR RSE eligible) Define eligible transmission customer SC for system resource (SR) and TSR (ex: transmission right owner, TSR with contract CRN) 	Core	Master File

 California ISO	Technology	Template Version:	6.8
		Document Version:	6.1.7
Extended Day Ahead Market Business Requirements Specification - Planning		Date Created:	1/21/2026

ID#	Business Feature	Requirement Type	Potential Application(s) Impacted
EDAM-BRQ-02052	EDAM SC and WEIM entity and resource shall have a one-to-one relationship <ul style="list-style-type: none"> • An EDAM Entity SC or EDAM Resource SC must have a one-to-one relationship with an EIM Entity or EIM Participating Resource it represents in the Energy Imbalance Market <ul style="list-style-type: none"> ○ One Entity SC represents the entity participating in EDAM and WEIM ○ One resource SC represents the resource participating in EDAM and WEIM ○ One-to-one relationship with resource and entity • Applicable EDAM LSE SC shall have a one-to-one relationship with the EIM Sub-Entity 	Process	Master File
EDAM-BRQ-02054	Nodal Price Model (NPM) supports only non-EDAM BAAs <ul style="list-style-type: none"> • NPM shall only support non-EDAM BAA, Remove NPM settings for the BAA that join EDAM- <ul style="list-style-type: none"> ○ BAA can be either NPM or EDAM, but cannot be both • DAM will continue to support NPM for new BAAs that subscribe to the NPM service. 	Process	Master File
EDAM-BRQ-02060	Define ISO and EDAM Internal supply Resource participation and eligibility for RSE For ISO: <ul style="list-style-type: none"> • All resources within the CAISO BAA will participate in the DAM market. • Define Resource sufficiency evaluation (RSE) eligible flags for DA-RSE ⊖ Internal supply resources are RSE-eligible if they are designated resources. All Gen and TG with SC association are RSE eligible. For EDAM BAA: <ul style="list-style-type: none"> • All resources within the EDAM BAA will participate in the DAM market. • Define Resource sufficiency evaluation (RSE) eligible flags for DA-RSE for the resource 	Core	Master File

 California ISO	Technology	Template Version:	6.8
		Document Version:	6.1.7
Extended Day Ahead Market Business Requirements Specification - Planning		Date Created:	1/21/2026

ID#	Business Feature	Requirement Type	Potential Application(s) Impacted
	<ul style="list-style-type: none"> If a resource participates in DA-RSE, it must participate in RT-RSE. However, there can be resources that participate in RT-RSE only (and not in DA-RSE). 		
EDAM-BRQ-02062	Define EDAM Supply Resource for capacity eligibility <ul style="list-style-type: none"> Extend eligibility flags for IRU/IRD, RCU/RCD to EDAM resources (from DAME) Specify EDAM resource flags for DAM, Energy, AS, same as ISO resources 	Core	Master File
EDAM-BRQ-02070	Define EDAM load Resource <ul style="list-style-type: none"> Define load resources for LSE in ELAP Define Load resource SC Define load forecast zone Define CLAP resource for third party load 	Process	Master File
EDAM-BRQ-02080	Define dynamic resource (TG) with RSE eligibility <ul style="list-style-type: none"> For ISO <ul style="list-style-type: none"> Define dynamic schedule or pseudo-tie resource to submit economic bids or self-schedules (SS) in EDAM Dynamic resource (TG) should be registered as RSE eligible For other EDAM BAA <ul style="list-style-type: none"> Define dynamic or pseudo-tie resource to submit economic bids or SS in EDAM Dynamic resource (TG) should be registered as RSE eligible Define network resource under OATT, register as TG, to submit economic bids for EN/IR/RC or SS energy in EDAM. The network resource shall be located in WEIM BAA, outside of EDAM BAA, and must be a physical resource Network resource under OATT, registered as TG, shall be RSE eligible 	Process	Master File

 California ISO	Technology	Template Version:	6.8
		Document Version:	6.1.7
Extended Day Ahead Market Business Requirements Specification - Planning		Date Created:	1/21/2026

ID#	Business Feature	Requirement Type	Potential Application(s) Impacted
	<ul style="list-style-type: none"> The dynamic schedule from one EDAM BAA to another EDAM BAA is not supported, SC shall bid from the resource in EDAM BAA and transfer TSR 		
EDAM-BRQ-02082	<p>Define system resource (SR) between EDAM BAA and non-EDAM BAA RSE eligibility</p> <ul style="list-style-type: none"> For ISO <ul style="list-style-type: none"> Define system resource to submit economic bids or self-schedule (SS) in EDAM Import System Resources at CISO interties are RSE-eligible only if associated with a contract (CRN or RA) PT export is RSE eligible For other EDAM BAA <ul style="list-style-type: none"> EDAM entity SC shall register static system resource (SR), can only self-schedule (SS) in EDAM, no economic bids All import/export system resources should be registered as RSE eligible <p>Note: PT – high priority export, with equal priority as load in Market</p>	Process	Master File
EDAM-BRQ-02083	<p>Define Mirror Resource for SR in non-EDAM BAA that is in a WEIM BAA</p> <ul style="list-style-type: none"> Set up the Mirror System Resource (MSR) in WEIM for mirroring the DA schedule between EDAM BAA and non-EDAM BAA that is a WEIM BAA. Define mirror resource on a WEIM BAA DGAP <ul style="list-style-type: none"> WEIM BAA will submit base schedule on MSR mirroring aggregated SR DA schedules of EDAM BAAs <ul style="list-style-type: none"> DA schedule can be the schedules for SR MF defined or dynamic formed transaction ID WEIM BAA can elect to set MSR as auto-mirror for the aggregated DA schedule of SRs between WEIM BAA and EDAM BAAs 	Core <u>Process</u>	Master File

 California ISO	Technology	Template Version:	6.8
		Document Version:	4.61.7
Extended Day Ahead Market Business Requirements Specification - Planning		Date Created:	1/21/2026

ID#	Business Feature	Requirement Type	Potential Application(s) Impacted
	Notes: Non-EDAM WEIM BAA need to set up and schedule mirror resource		
EDAM-BRQ-02083a	Process existing Mirror System Resources (MSR) <ul style="list-style-type: none"> Existing MSRs for EIM BAAs not joining EDAM that mirror DA CISO import/export schedules at CISO Scheduling Points will be preserved, but the MSR location will exist at the same location that the SC uses to bid and/or self-schedule at the tie of the EDAM Entity (can be SP-Tie or GAP-TIE) Existing MSRs for EIM BAAs joining EDAM that mirror DA CISO import/export schedules at CISO Scheduling Points will be retired; EDAM Transfers will be used instead 	Core Process	Master File
EDAM-BRQ-02083b	Support Auto-mirror MSR for DA schedule <ul style="list-style-type: none"> Setup Auto-mirror for MSR at the same location that the SC uses to bid and/or self-schedule at the tie of the EDAM Entity There shall be one MSR per EDAM BAA intertie for each WEIM BAA at which SCs may bid import/exports to/from the CISO BAA and the WEIM BAA 	Core Process	Master File
EDAM-BRQ-02084	Define wheel through EDAM BAA schedule <ul style="list-style-type: none"> A wheel through an EDAM Entity BAA from an EDAM External Intertie location to another EDAM External Intertie location, balance self-schedule import/export—same as wheel setup for ISO Define Wheel through ISO schedule from non-EDAM BAA to non-DEAM BAA—same as today 	Process	Master File
EDAM-BRQ-02085	 Define Super DGAP (SDGAP) hubs for system resource without location for non-EDAM BAAs <ul style="list-style-type: none"> Super DGAP(SDGAP) shall associate directly with Pnodes of non-EDAM BAAs in WECC Define multiple SDGAP hubs, <ul style="list-style-type: none"> North SDGAP, include WECC northwest non-EDAM BAA's pnodes, define the list South SDGAP, include WECC southwest non-EDAM BAAs' pnodes, except Mexico (CFE), define the list: <ul style="list-style-type: none"> North SDGAP and South SDGAP shall not overlap 	Core	Master File



ID#	Business Feature	Requirement Type	Potential Application(s) Impacted
	<ul style="list-style-type: none"> ○ If a BAA joins EDAM, remove the BAA from associated SDGAPs ● The default GDF for SDGAP is derived from the underlying non-EDAM BAAs' default GAP's GDF ● Define the Apnode on the SDGAPs <p>Note: Path 15 to separate North and South</p>		
EDAM-BRQ-02086	<p>Define DGAP association with Interties and scheduling point (SP) and ITC/ISL</p> <ul style="list-style-type: none"> ● All SR at SP need to specify the DGAP location—register the SR and DGAP in the RDT ● The alternate tie should specify the DGAP and associated ISL constraint. 	Core	Master File RDT
EDAM-BRQ-02087	<p>Associate DGAP-TIE, Tie to- ITC</p> <ul style="list-style-type: none"> ● Define DGAP and TIE mapping ● Define SDGAP and TIE mapping, <ul style="list-style-type: none"> ○ associate north/south SDGAP with corresponding north/south TIE, ● Define TIE-ITC mapping. 	Core Process	Master File
EDAM-BRQ-02088	<p>Associate DGAP and System resources (SR) that are currently defined at CAISO Scheduling Point (SP)</p> <ul style="list-style-type: none"> ● Communication with existing SR resource SC to register the DGAP location ● SC of SR shall submit the association of DGAP of BAA or super DGAP location for the SR 	Process	Master File
EDAM-BRQ-02089	<p>Define system resource (SR) with unknown location at specified non-EDAM DGAP for ISO and EDAM</p> <ul style="list-style-type: none"> ● Terminate the registered system resource between two EDAM BAAs and between EDAM BAA and ISO, except for RA ● RA resource at ISO SP will have the following rules: <ul style="list-style-type: none"> ○ RA is scheduled between ISO and EDAM BAA through RSE eligible TSR ○ RA is mapped to non-EDAM DGAP, keep SR and Mirror for RTM if it is WEIM BAA, ex: Mona SP for RA, Malin SP 	Core	Master File

 California ISO	Technology	Template Version:	6.8
		Document Version:	4.61.7
Extended Day Ahead Market Business Requirements Specification - Planning		Date Created:	1/21/2026

ID#	Business Feature	Requirement Type	Potential Application(s) Impacted
EDAM-BRQ-02089 a	<p>Model existing SR for ISO</p> <ul style="list-style-type: none"> • The location of System Resources with DA import/export schedules at CISO Scheduling Points from/to non-EDAM BAAs in DAM will move to the source/sink BAA DGAP • The location of System Resources with DA import/export schedules at CISO Scheduling Points from/to non-EIM BAAs in RTM will move to the source/sink BAA DGAP • The Scheduling Point and inertia association of the System Resources in (1-2) above will be preserved 	Process	Master File
EDAM-BRQ-02090	<p>Resources not eligible for DA resource sufficiency evaluation for ISO and EDAM:</p> <ul style="list-style-type: none"> • Non-PT exports are not RSE eligible • Wheel through schedules are not RSE eligible • Convergence bid resources are not eligible for RSE • Load resources are not eligible for RSE • If internal resource are pseudo-tie out for other BAA, they are non-RSE eligible 	Process	Master File
EDAM-BRQ-02100	<p>Define paired DA TSRs resource ID of paired EDAM BAAs</p> <ul style="list-style-type: none"> • EDAM entity SCs register DA TSR, paired TSRs (Import/Export) for paired EDAM BAAs in the same manner as in WEIM: <ul style="list-style-type: none"> ○ DA TSR is defined as a separate variable, in addition to the WEIM Base ETSR, static/dynamic ETSR • Designate one of the paired DA TSR as the one to submit tag for DA TSR and mirror resource same as for WEIM Base • DA TSR can model transfer of energy, IRU/IRD, RCU/RCD in the DAM 	Core	Master File
EDAM-BRQ-02130	<p>Register contracts/transmission rights (CRN) for ETC/TOR/OATT associated with DA TSR</p> <p>For the transfer capacity that under transmission right contract:</p> <ul style="list-style-type: none"> • Define the transfer resource paired DA TSR resources associated with contract CRN <ul style="list-style-type: none"> ○ Define the CRN contract same as today for CAISO: PTP or Network, transmission rights, start and end date, impact an inertia, schedule priority, congestion reversal, loss reversal 	Core	Master File

 California ISO	Technology	Template Version:	6.8
		Document Version:	6.1.7
Extended Day Ahead Market Business Requirements Specification - Planning		Date Created:	1/21/2026

ID#	Business Feature	Requirement Type	Potential Application(s) Impacted
	<ul style="list-style-type: none"> ○ For CRN_TYPE “OATT1” or “OATT2”, a TRANSFER_LOCATION_ID may be used instead of a RES_ID as a source or sink. • Define the transmission customer SC for the DA TSR with CRN, allow the paired DA TSR to have the same SC • For ETC/TOR: EDAM entity shall register both the physical and financial locations • Define two new contract types for OATT, in addition to ETC, TOR <ul style="list-style-type: none"> ○ OATT 1: higher scheduling priority in RT than DA schedules ○ OATT 2: equal scheduling priority with DA schedules in RT ○ Note: All other attributes for OATT 1 and OATT 2 are the same 		
EDAM-BRQ-02134	<p>Register contracts/transmission rights (CRN) associated with EDAM BAA internal legacy transmission contracts</p> <ul style="list-style-type: none"> • Define EDAM internal legacy transmission contracts in the same way as ETC/TOR for ISO. <p>Note: EDAM will extend the model for ISO’s ETC/TOR to EDAM BAAs to accommodate the legacy contracts in the EDAM BAAs.</p>	Core	Master File
EDAM-BRQ-02140	<p>Define GHG regulation areas for DAM and RTM</p> <ul style="list-style-type: none"> • Define GHG regulation area (E.g. California, Washington) • Define GHG area Anode and to map the Cnodes • Allow DAM and RTM to have different GHG regulation area boundaries. Define GHG regulation area association with DAM GHG regulation area, RTM GHG regulation area <p>Example: the CAISO BAA and other CA BAAs are in the California GHG regulation in RTM, but the CAISO BAA could be the only BAA in the California GHG regulation in the DAM:</p> <ul style="list-style-type: none"> • Define 3 regulation Anodes for CA: define overall CA GHG Regulation Anodes, DA CA GHG regulation Anodes, and RT CA GHG regulation Anodes. DA and RT are linked to overall CA to support deviation Settlements. 	Core	Master File

 California ISO	Technology	Template Version:	6.8
		Document Version:	6.1.7
Extended Day Ahead Market Business Requirements Specification - Planning		Date Created:	1/21/2026

ID#	Business Feature	Requirement Type	Potential Application(s) Impacted
EDAM-BRQ-02141	<p>Map GHG regulation areas and associated internal resources for all WEIM and EDAM BAAs that overlap with CA state and/or WA state</p> <ul style="list-style-type: none"> Any WEIM BAA that overlaps with Washington State and/or CA State must provide the substation-to-state mapping for all existing and new/future substations For each GHG regulation area, associate internal supply resources and demand resources <p>Note: Internal resources with GHG compliance obligations for the GHG regulation area will include GHG cost in energy bids for this GHG area. These internal resources will not submit a GHG bid adder for the GHG regulation area with which the resource is associated. These internal resources may submit GHG bid adders to serve load in other GHG regulation areas.</p>	Core	Master File
EDAM-BRQ-02142	<p>Define GHG contractual MW and compliance obligation for resources outside a GHG regulation area to serve demand in that GHG regulation area</p> <ul style="list-style-type: none"> The EDAM Entity scheduling coordinator must register whether their supply resource has contractual MW obligations (includes RA and non-RA) to serve load in another BAA if that BAA overlaps with a GHG regulation area. <ul style="list-style-type: none"> A resource should not be GHG pseudo-tied to the GHG Regulation Area Sum of contractual MW to multiple GHG regulation areas cannot exceed resource Pmax EDAM Entity SC must provide MW committed and the start and end dates of the commitment Register contractual MW obligations at hourly granularity (i.e. one MW value per hour per resource) Follow standard MF change process (i.e. system shall not support dynamic changes for this process) 	Core	Master File RDT
EDAM-BRQ-02143	<p>Split existing WEIM Load Aggregation Points (ELAPs) across GHG states boundaries</p> <ul style="list-style-type: none"> ELAPS shall be defined for each portion of a BAA that overlaps with a GHG regulation area and for each portion of a BAA that 	Core	Master File

 California ISO	Technology	Template Version:	6.8
		Document Version:	6.1.7
Extended Day Ahead Market Business Requirements Specification - Planning		Date Created:	1/21/2026

ID#	Business Feature	Requirement Type	Potential Application(s) Impacted
	does not overlap with a GHG regulation area, based on CNODE coordinates. <ul style="list-style-type: none"> ○ Entity coordination likely required 		
EDAM-BRQ-02144	Establish and maintain association of nodes and resources as described in BRQ-02143	Business Process	Master File
EDAM-BRQ-02145	Define Resource GHG pseudo-tie flag for the specified GHG area GHG pseudo-tie must be an energy pseudo-tie resource, no GHG bid adders are allowed under this model. This attribute shall be submitted by the SC <ul style="list-style-type: none"> • Only resources in a BAA that partially overlaps with a GHG regulation area shall have the option to elect the GHG pseudo tie attribute • Resources not located in a BAA that overlaps with a GHG regulation area must establish a pseudo-tie into a BAA that overlaps with a GHG regulation area to be able to elect GHG pseudo tie • System shall not support GHG pseudo-tie from one GHG area to another GHG area without a pseudo-tie established • GHG pseudo-tie resources shall include GHG cost in energy bids and DEBs Note: In IFM/RTM, GHG constraint shall consider this resource to be GHG internal resource → no GHG attribution.	Core	Master File
EDAM-BRQ-02146	Define Intertie (Tie ID) association with GHG Regulation Area Define the Tie IDs of the BAA with GHG regulation areas: <ul style="list-style-type: none"> • The BAA shall overlap with one or more GHG regulation areas • One Tie shall only be associated with one GHG regulation area • The different Ties of the BAA can be associated with different GHG regulation areas if the BAA overlaps with more than one GHG regulation area 	Core	Master File
EDAM-BRQ-02150	Define the GHG bid adder framework <ul style="list-style-type: none"> • The definition of a new GHG area in MF shall activate the GHG bid adder framework for that area (i.e. activation of GHG bid adders, LMPs including GHG components) 	Business Process	Process

 California ISO	Technology	Template Version:	6.8
		Document Version:	4.6 1.7
Extended Day Ahead Market Business Requirements Specification - Planning		Date Created:	1/21/2026

ID#	Business Feature	Requirement Type	Potential Application(s) Impacted
EDAM-BRQ-02180	Define GMC rate for EDAM BAAs <ul style="list-style-type: none"> • Split current System Operation GMC Charge into two elements: <ul style="list-style-type: none"> ○ System Operations Real-Time Dispatch: SYSOPRTD <ul style="list-style-type: none"> ▪ Applicable EDAM and CAISO BAA ○ System Operations Balancing Authority Area Services: SYSOPBAA <ul style="list-style-type: none"> ▪ Applicable to CAISO BAA only ○ For WEIM only: The WEIM GMC System Operation Component will continue to settle at the current WEIM GMC System Operations Component (ESYSOPR) rate. The ESYSOPR rate shall be equal to the SYSOPRTD rate • System shall define the Extended Day-Ahead Market (EDAM) Transitional Load Ramp-In for applicable EDAM BAAs 	Core	Master File
EDAM-BRQ-02185	Define a flag that indicates whether a BAA overlaps with GHG regulation area <ul style="list-style-type: none"> • Include a flag for BAAs that wholly or partially overlap with GHG regulation area (do not need to differentiate between whole or partial overlap) 	Core	Master File
EDAM-BRQ-02190	Define GHG regulation area and network branch association <ul style="list-style-type: none"> • Based on the GHG area Apline and Cnode, if branch is within the GHG regulation area, define an attribute to associate branch with GHG regulation area 	Core	Internal ISO System
EDAM-BRQ-02220	Define EDAM BAA Imbalance Demand Hub <ul style="list-style-type: none"> • Define anode, APnode for EDAM BAA Imbalance demand Hub, include load nodes, solar resource Cnodes and Wind resource Cnodes 	Core DAME	Master File
EDAM-BRQ-02250	Extend Definition and accessibility of Imbalance Demand Hub to EDAM BAAs (refer to DAME-BRQ-01150) System shall extend the definition and accessibility Imbalance Demand Hub to EDAM BAAs.	Core	Master File

 California ISO	Technology	Template Version:	6.8
		Document Version:	4.6 1.7
Extended Day Ahead Market Business Requirements Specification - Planning		Date Created:	1/21/2026

ID#	Business Feature	Requirement Type	Potential Application(s) Impacted
EDAM-BRQ-02260	Allow EDAM entities to submit use-limited data <ul style="list-style-type: none"> System shall allow EDAM entities to submit use-limited data in the same manner as in WEIM today Data shall be displayed on the Actual Limitation Values and Opportunity Cost CMRI reports (under the Default Bids category) 	Core	Master File
EDAM-BRQ-02270	Define AS region(s) for each EDAM BAA <ul style="list-style-type: none"> For non-CAISO EDAM BAAs, default setting is to define one AS region for each BA. 	Core	Master File
EDAM-BRQ-02290	Extend to EDAM: Set RUC Participation Flag for LESRs to Yes <ul style="list-style-type: none"> RUC participation flag for LESRs shall be set to Y, starting from Tariff activation date. This participation flag setting shall override the previous flag setting for the remainder of the year. 	Process	MF
EDAM-TSR-BRQ-02051 a	Define entity registered TSRs with TSR type and associate with applicable SC <ul style="list-style-type: none"> EDAM entity is responsible for registering all of the non-transient TSRs in their BAA Paired TSRs must have the same TSR type on each side of transfer Type 1 and Type 2 TSRs are associated with a transmission customer SC (TCSC), Type 3 and Type 4 TSRs are associated with an EDAM entity SC (EESC) Each DA TSR shall associate with one of the four TSR types: <ul style="list-style-type: none"> Type 1: Bilateral energy transactions between TCs <ul style="list-style-type: none"> Associate with TCSC: may be the same or different SC for each side of paired TSRs One side of TSR pair must have CRN: can be same or different CRN for each side of paired TSRs <ul style="list-style-type: none"> Must also define matching TSR CRN ID CRN ID on one side may be designated "NONE" (see EDAM-TSR-BRQ-02051c) 	Core Process	Master File

 California ISO	Technology	Template Version:	6.8
		Document Version:	6.1.7
Extended Day Ahead Market Business Requirements Specification - Planning		Date Created:	1/21/2026

ID#	Business Feature	Requirement Type	Potential Application(s) Impacted
	<ul style="list-style-type: none"> ▪ RSE eligible ○ Type 2: Capacity from TCs that release their transfer rights at a transfer location <ul style="list-style-type: none"> ▪ Associate with TCSC: may be the same or different SCs for each side of paired TSRs ▪ Not RSE eligible ▪ One side of TSR pair must have CRN: can be same or different CRN for each side of paired TSRs <ul style="list-style-type: none"> • Must also define matching TSR CRN ID • CRN ID on one side may be designated "NONE" (see EDAM-TSR-BRQ-02051c) ○ Type 3: RSE-eligible transfer capacity released by EDAM Entities <ul style="list-style-type: none"> ▪ Associate with EESC: different SCs for each side of paired TSR ▪ Must have RSE eligible flag=Y ▪ Both sides of paired TSR must be RSE eligible ▪ No associated CRN ○ Type 4: Non-RSE eligible transfer capacity released by EDAM entities <ul style="list-style-type: none"> ▪ Associate with EESC: different SCs for each side of paired TSR ▪ Must have RSE eligible flag=N ▪ No associated CRN <p>Notes:</p> <ul style="list-style-type: none"> • TCSC is SC for the resource (i.e. not a separate SC) • TSR type is defined only for DA TSRs, not for WEIM ETSRs 		
EDAM-TSR-BRQ-02051b	Define Generic Entity SCs for Transfers with CAISO BAA (applies to CAISO only) <ul style="list-style-type: none"> • For TSRs with the CAISO, define both EESC and TCSC as "CISO" (existing SC) 	Process	Master File
EDAM-TSR-	Support generic CRN ID: any contract served or sourced by an EDAM BAA (including CAISO) for Type 1 TSRs	Process	Master File

 California ISO	Technology	Template Version:	6.8
		Document Version:	6.1.7
Extended Day Ahead Market Business Requirements Specification - Planning		Date Created:	1/21/2026

ID#	Business Feature	Requirement Type	Potential Application(s) Impacted
BRQ-02051 c	<ul style="list-style-type: none"> • Support generic, unbalanced CRN for TSR Type 1 matching with actual CRN on other side of transfer <ul style="list-style-type: none"> ◦ This CRN has no financial or physical rights • Support CRN ID as: "NONE" 		
EDAM-TSR-BRQ-02051 d	<p>Define DA TSR attributes:</p> <ul style="list-style-type: none"> • RES_ID: Resource ID: <ul style="list-style-type: none"> ◦ Use the following naming convention: SC ID FROM BAA ID TO BAA ID INTERTIE ID DIRECTION_TSR_TYPE_nn <ul style="list-style-type: none"> ▪ Where 'nn' is an alphanumeric identifier to distinguish otherwise similar transfers • SC_ID: Scheduling Coordinator • MAX_CAP: Maximum Capacity • TRANSFER_LOCATION_ID: Registered Transfer Location (see EDAM-TSR-BRQ-) • FROM_BAA: From Side BAA • TO_BAA: To Side BAA • IMPORT/EXPORT: Flow directions (I/E) • TSR_TYPE: (1,2,3,4) one number • RSE_YN: RSE eligibility (Y/N) • TAG_YN: Tag Flag <ul style="list-style-type: none"> ◦ This election overrides the tag flag setting defined in the Transfer Location (if different) • CRN_ID: contract number if applies to TSR Type 1 or Type 2 <ul style="list-style-type: none"> ◦ Includes ETC/TOR, and OATT 1/OATT 2 • MATCHING_TSR: Matching TSR Resource ID • TRANSFER_COST: default value unless requested by EESC <p>Note: See EDAM-TSR-BRQ-12043 for default transfer costs as defined in DAM/RTM</p>	Core	Master File
EDAM-TSR-BRQ-02051 e	<p>Define Transfer Location, including Tag Responsibility and Transfer Revenue Distribution Factor (RDF), as APNode</p> <ul style="list-style-type: none"> • TRANSFER_LOCATION_ID: FROM_BAA_ID_TO_BAA_ID_INTERTIE_ID_DIRECTION • FROM_BAA_ID: must be a registered EDAM BAA • TO_BAA_ID: must be a registered EDAM BAA, different from the FROM BAA ID • INTERTIE_ID: must be a registered Intertie • IMPORT/EXPORT: Flow direction (I/E) 	Core	Master File

 California ISO	Technology	Template Version:	6.8
		Document Version:	6.1.7
Extended Day Ahead Market Business Requirements Specification - Planning		Date Created:	1/21/2026

ID#	Business Feature	Requirement Type	Potential Application(s) Impacted
	<ul style="list-style-type: none"> • FROM_BAA_TAG_YN flag • TO_BAA_TAG YN Flag <ul style="list-style-type: none"> ◦ One, and only one, BAA in the pair must have the TAG_YN flag set to Y • FROM_BAA_RDF (Transfer Revenue Distribution Factor among the BAA pair) • TO_BAA_RDF <ul style="list-style-type: none"> ◦ FROM/TO BAA RDF must be between 0 and 1, and must add to 1 for each pair ◦ Note: the same RDF shall apply to all TSRs at an intertie between two BAAs • MATCHING_TRANSFER_LOCATION_ID • Transfer Location will also be included as an APNode with an APNode type of Transfer Location <p>Note:</p> <ul style="list-style-type: none"> • Either the FROM_BAA or TO_BAA of the intertie definition should match either the FROM_BAA or TO_BAA of the TRANSFER_LOCATION_ID • When needed, Transfer location can be mapped to an ITC (see EDAM-TSR-BRQ-02051g) 		
EDAM-TSR-BRQ-02051f	Allow Transfer Location to be a valid source or sink for a CRN TRANSFER_LOCATION_ID (as described in EDAM-TSR-BRQ-02051e) shall be a valid source or sink for any CRN	CoreProcess	Master File
EDAM-TSR-BRQ-02051g	Map Transfer Location to ITC <ul style="list-style-type: none"> • Map each MF-defined TRANSFER_LOCATION_ID to the applicable ITC, as necessary 	Process	Master File
EDAM-TSR-BRQ-02100	Paired TSR Definition Cross Validation for Registered TSRs System shall cross validate TSR definition with matching TSR definition (MATCHING TSR ID) on each side of transfer location. Specifically, the following attributes shall be validated for matching TSRs: <ul style="list-style-type: none"> • TRANSFER_LOCATION_ID of the TSR must match the MATCHING_TRANSFER_LOCATION_ID of the mirror TSR 	Core	Master File

 California ISO	Technology	Template Version:	6.8
		Document Version:	6.1.7
Extended Day Ahead Market Business Requirements Specification - Planning		Date Created:	1/21/2026

ID#	Business Feature	Requirement Type	Potential Application(s) Impacted
	<ul style="list-style-type: none"> • TSR_TYPE must match 		
EDAM-TSR-BRQ-02315	<p>Entity CRN Registration</p> <p>The EESC shall register CRNs with the following attributes:</p> <ul style="list-style-type: none"> • CRN_ID • CRN_ENTITLEMENT • CRN_TYPE • PHYSICAL_RIGHT • PHYSICAL_RIGHT_LEVEL <ul style="list-style-type: none"> ○ TOR ○ ETC ○ OATT 1 ○ OATT 2 • FINANCIAL_RIGHT • FINANCIAL_SOURCE • FINANCIAL_SINK • FINANCIAL_SC • EXPIRATION • BAA_ID <ul style="list-style-type: none"> ○ TRANSFER_LOCATION_ID: optional <ul style="list-style-type: none"> ▪ TC SC_ID, CRN_CAPACITY for that TC SC_ID including any registered TSR Type 1 ▪ Note: This information will be used for validating TSR Type 1 bids and Released Capacity Bids at that Transfer Location ○ RES_ID, CRN_CAPACITY for that RES_ID: required for registered TSRs (PHYSICAL_SOURCE, PHYSICAL_SINK) 	Core	Master File
EDAM-TSR-BRQ-02316	<p>Define Transfer Location for WEIM ETSRs as Apnode</p> <ul style="list-style-type: none"> • Using the same design as for DA TSR Transfer Location, as described in EDAM-TSR-BRQ-02051e, define Transfer Location as an Apnode for all WEIM ETSRs 	Core <u>Proc</u> <u>ess</u>	MF

 California ISO	Technology	Template Version:	6.8
		Document Version:	4.61.7
Extended Day Ahead Market Business Requirements Specification - Planning		Date Created:	1/21/2026

ID#	Business Feature	Requirement Type	Potential Application(s) Impacted
EDAM-TSR-BRQ-02317	Map WEIM ETSR to the appropriate Transfer Location <ul style="list-style-type: none"> Associate each WEIM ETSR with the corresponding Transfer Location, as defined in EDAM-TSR-BRQ-02315 <p>Note: no changes to the WEIM ETSR Resource IDs</p>	Process	MF
EDAM-TSR-BRQ-02318	Remove Existing Base ETSR Apnodes <ul style="list-style-type: none"> Remove existing Apnodes that are associated with WEIM ETSRs. Base ETSR Apnode mapping shall be updated to Transfer Location, as defined in EDAM-TSR-BRQ-02316 	Core Process	MF
EDAM-BRQ-02330	Set EDAM Participating Flag to Yes for EDAM TOPs <ul style="list-style-type: none"> The system shall set the EDAM_PARTICIPATING Flag to Y for all EDAM TOPs (e.g. PAC_TOP) 	Process	MF
EDAM-BRQ-02345	New Flag to Define which SCs can schedule at GAPSP-TIEs <ul style="list-style-type: none"> The system shall develop a new flag to support EDAM Resource SCs registration by GAPSP-TIE: differentiate between generic/open GAPSP-TIEs and restricted GAPSP-TIEs <ul style="list-style-type: none"> Generic GAPSP-TIEs: any SC can schedule at these GAPSP-TIEs Restricted GAPSP-TIE: only the SCs mapped to the GAPSP-TIE can schedule at the GAPSP-TIE combination (new mapping required). <ul style="list-style-type: none"> Note: GAPSP-TIE combination may be restricted and have no SCs mapped to it 	Core	MF
EDAM-BRQ-02346	Set RT Participation Flag for Resources based on GAP Association <ul style="list-style-type: none"> For registered resources at a WEIM DGAP: the RT Participation Flag is N For registered resources at a non-WEIM GAP: the RT Participation Flag is Y For registered resources at a SGAP: the RT Participation Flag is N No resource can be registered at an EDAM DGAP, except for TSRs 	Core	MF

 California ISO	Technology	Template Version:	6.8
		Document Version:	4.61.7
Extended Day Ahead Market Business Requirements Specification - Planning		Date Created:	1/21/2026

ID#	Business Feature	Requirement Type	Potential Application(s) Impacted
EDAM-BRQ-02346	Perform Outreach to All SCs with Registered Import/Export Resources (including TGs) whose RT Participation Flag is Changing <ul style="list-style-type: none"> RT Participation Flag changes described in EDAM-BRQ-02346a 	Process	ME
EDAM-BRQ-02350	Interchange Resources in WEIM BAAs shall not be eligible to provide Imbalance Reserves or Reliability Capacity in EDAM <ul style="list-style-type: none"> Interchange resources sourced from a SGAP or DGAP within a WEIM area shall not be eligible to provide IRU/IRD or RCU/RCD 	Process	MF
EDAM-IST-BRQ-02280	Define Trading Hubs and resource association for EDAM and WEIM BAAs For each EDAM BAA or WEIM BAA Define the one or more Trading Hubs <ul style="list-style-type: none"> For CISO, keep existing two Trading Hubs For EDAM BAA, allow EDAM entity to define one or more trading hubs, if the BAA only have one Trading hub, define trading hub on the DGAP. For the BAAs in both the EDAM and WEIM, the same Trading hubs are applicable for EDAM and WEIM. For the BAA is in WEIM only, define the trading hub include Participating resource and Non-participating resources, same as for DGAP. The Generating resource in each EDAM or WEIM BAA must be associated with one and only one Trading Hub 	Process	ME
EDAM-BRQ-02355	Define Additional DGAP Tie to Mirror Resource Mapping to Enable Indirect Scheduling <ul style="list-style-type: none"> ME shall NOT define MSRs for BAAs that are set up to use indirect scheduling on that tie 	Core	ME

 California ISO	Technology	Template Version:	6.8
		Document Version:	4.6 1.7
Extended Day Ahead Market Business Requirements Specification - Planning		Date Created:	1/21/2026

5.2 Business Process: Manage Forecasting (ALFS)

- Load forecast and publication for EDAM BAAs every 30 minutes (configurable) between 6 am-9am
- VER forecast and publication for EDAM BAAs every 30 minutes (configurable) between 6 am-9am
- DR adjustment (Extend RSEE 2 DR functionality to EDAM)

5.2.1 Business Requirements

ID#	Business Feature	Requirement Type	Potential Application(s) Impacted
EDAM-BRQ-04010a	Forecast System to Forecast load for all EDAM forecast zone levels between 6 am and 9 am <ul style="list-style-type: none"> • CAISO STF forecast load at the EDAM BAA level for all EDAM entities • CAISO STF forecast load for all custom LAP forecast zones 	Core	ALFS
EDAM-BRQ-04010b	System will make the forecasts available every 30 minutes for all forecast zones between 6am and 9am	Core	ALFS
EDAM-BRQ-04012	Allow EDAM entities to select ISO forecasted load or self-provided forecasted load <ul style="list-style-type: none"> • Access MF DA and RT selections that are required to match • Selection timing and changes to selections shall follow the development process outlined in Tariff §Appendix Q (minimum of 30 days) • If any sub-entity elects to self-provide forecasts, the entire entity shall self-provide forecasts 	Core	ALFS
EDAM-BRQ-04013a	ISO and self-provided Load forecasts shall follow existing DAM timing and granularity: <ul style="list-style-type: none"> • Submit DA through day 7 forecasts in hourly granularity, at the Region Level • Allow for updates to forecasts for advisory RSE runs every 30 minutes between 6 am and 9 am 	Business Process	ALFS ALFSSOA

 California ISO	Technology	Template Version:	6.8
		Document Version:	4.6 1.7
Extended Day Ahead Market Business Requirements Specification - Planning		Date Created:	1/21/2026

ID#	Business Feature	Requirement Type	Potential Application(s) Impacted
	<ul style="list-style-type: none"> ○ Include processing time buffer (exact amount TBD) ahead of 6 am and 9 am for self-provided forecast submission ● If no self-provided forecast is submitted, back-fill with ISO forecast 		
EDAM-BRQ-04013b	<p>ISO and self-provided VER forecasts shall follow existing DAM timing and granularity:</p> <ul style="list-style-type: none"> ● Submit DA through day 7 forecasts in hourly granularity, at the Resource ID level (not BAA level) ● Allow for updates to forecasts for advisory RSE runs every 30 minutes between 6 am and 9 am 	Business Process	ALFS ALFSSOA
EDAM-BRQ-04014	<p>EDAM entity data submission requirements for CAISO to build forecasts</p> <ul style="list-style-type: none"> ● EDAM Document Stating Forecast Boundaries of Conforming/Non-Conforming Load and choice of demand forecast provider for Market and RC ● EDAM Identification Document on Weather Stations ● 5-year historical load data ● Weather Stations ● Zip code mapping (to assist with BTM/DER incorporation) <p>Note: If the entity already uses ISO forecast in WEIM, no new data is needed</p>	Business Process	ALFS
EDAM-BRQ-04020a	<p>System shall make available hourly VER forecast every 30 minutes between 6am and 9am, and at 9:30 am</p>	Core	ALFSSOA
EDAM-BRQ-04020b	<p>Forecast System to generate VER forecast for every EDAM entity</p>	Core	ALFS

 California ISO	Technology	Template Version:	6.8
		Document Version:	4-6 1.7
Extended Day Ahead Market Business Requirements Specification - Planning		Date Created:	1/21/2026

ID#	Business Feature	Requirement Type	Potential Application(s) Impacted
EDAM-BRQ-04021	<p>Allow EDAM entities to select ISO VER forecast or self-provided VER forecast</p> <ul style="list-style-type: none"> • EDAM Document from EDAM BAA stating selection of VER Forecast Provider • Access selection of ISO provided for self-provided that is performed in MF • DA and RT selections are required to match • Forecast fee shall be charged to entities that consume ISO provided forecasts for either DAM or RTM • Selection timing and changes to selections shall follow the development process outlined in Tariff §Appendix Q (minimum of 30 days) • If any WEIM BAA entity breakout elects to self-forecast, the entire BAA shall provide self-forecasts 	Core	ALFS (from MF)
EDAM-BRQ-04032	<p>Forecast shall not be modified to account for DA RDRR. RDRR is treated as supply in RT</p>	Business Process	ALFS
EDAM-BRQ-04040	<p>Access EDAM and WEIM Entities Participation Flags System shall access the following data from MF:</p> <ul style="list-style-type: none"> ○ EDAM Participation Flag (and its activation date) ○ WEIM Entity Flag (and its activation date) 	Core	ALFSSOA (MF)
EDAM-BRQ-04051	<p>Access DR Inclusion Data from MF (refer to RSEE2-BRQ-02020)</p> <ul style="list-style-type: none"> • System shall access the following data from MF: <ul style="list-style-type: none"> ○ DR Inclusion Flag <ul style="list-style-type: none"> ▪ (Entity level, whether EDAM Entity, WEIM-only Entity) ○ System shall translate the EDAM/WEIM-only Entity flag to their associated LF zones. <p>Note: If the translated flag is enabled for a LF zone, it shall allow the entity with which it is associated and</p>	Core	ALFSSOA

 California ISO	Technology	Template Version:	6.8
		Document Version:	6.1.7 1.7
Extended Day Ahead Market Business Requirements Specification - Planning		Date Created:	1/21/2026

ID#	Business Feature	Requirement Type	Potential Application(s) Impacted
	responsible for its LF submission (whether it is EDAM/WEIM-only Entity) to submit Non-Participating DR Schedules for that LF zone.		
EDAM-BRQ-04052	<p>Consume Non-Participating DR Schedules from EDAM Entity (refer to RSEE2-BRQ-02040)</p> <p>System shall have the capability to automatically consume the following from EDAM Entities that plan to utilize DR that are not explicitly modeled in DAM/RTM (DRPs that are not able to be represented by the PDR or RDRR models), for Load Forecast (LF) zones that have enabled DR Inclusion Flag, using similar mechanism as receiving existing LF:</p> <ul style="list-style-type: none"> Non-Participating DR Schedules <p>Notes</p> <ul style="list-style-type: none"> Remove the threshold 5% of LF for DR inclusion EDAM Entity by default is WEIM Entity too and all rules applicable to WEIM RSEE requirements shall be applicable to the EDAM Entities. Submitted Non-Participating DR Schedules shall be in 5-min granularity, and they are on-demand submission. If 15-min granularity schedule is desired, participants shall enter same schedule for each 5-min within the corresponding 15-min. If hourly granularity schedule is desired, participants shall enter same schedule for each 5-min within the corresponding hour. The DRPs can be reflected as an increase in load that captures expected “pre-cooling” as well as a decrease in LF that reflects the DR event itself. Currently, data is received via spreadsheet by 8 am. Receive time being pushed up to 7 am 	Core	ALFS ALFS <u>SEWS</u>
EDAM-BRQ-04052a	<p>Receive Non-Participating DR Schedules from WEIM Entity or WEIM Sub-Entity</p> <ul style="list-style-type: none"> System shall have the capability to automatically receive the following from WEIM Entities and/or Sub-Entities that plans to utilize a DR that are 	Core	ALFS- SOAEWS

 California ISO	Technology	Template Version:	6.8
		Document Version:	6.1.7
Extended Day Ahead Market Business Requirements Specification - Planning		Date Created:	1/21/2026

ID#	Business Feature	Requirement Type	Potential Application(s) Impacted
	not explicitly modeled in RTM (DRPs that are not able to be represented by the PDR or RDRR models), for LF zones that have enabled DR Inclusion Flag, using similar mechanism as receiving existing LF: <ul style="list-style-type: none"> Non-Participating DR Schedules in 5-minute granularity Note: This applies to WEIM Entities and CISO BAA load forecast zone.		
EDAM-BRQ-04053	For consideration in DA Demand Forecast Process, non-Participating DR Schedules shall be consumed from the EDAM Entity by 7am (8am submittals will be considered in exceptional circumstances). <ul style="list-style-type: none"> Any submittals after 8am cannot be incorporated into demand forecast adjustment 	Business Process	ALFS ALFSSOA
EDAM-BRQ-04058	Accounting for DR LF Adjustment in DA Demand Forecast Process (refer to RSEE2-BRQ-02160) For each EDAM BAA, System shall utilize applicable business process to: <ul style="list-style-type: none"> Include DR schedule in the load forecast (LF), eliminate the 5% threshold so that all submittals are included in ALFS LF 	Core	ALFS
EDAM-BRQ-04060	Broadcast Load forecast (LF) with applicable DR adjustment (refer to RSEE2-BRQ-02180) <ul style="list-style-type: none"> Broadcast for BAA level and each LF zone that is associated with EDAM BAA and/or Sub-Entity, for the LF with DR adjustment, same as broadcasting existing LF in DAM 	Core	ALFS ALFSSOA
EDAM-BRQ-04065	When a CLAP level forecast exists for a BAA: distribute BAA level forecast to the CLAP levels using load distribution factors	Existing	ALFS
EDAM-BRQ-04070	Support additional FSP reports (VER, BTM, and weather forecasts) Consume from FSP additional reports	Business Process	ALFS

 California ISO	Technology	Template Version:	6.8
		Document Version:	6.1.7 1.7
Extended Day Ahead Market Business Requirements Specification - Planning		Date Created:	1/21/2026

5.3 Business Process: Manage BAA Requirement Calculation

- Extend IRU/IRD requirement forecast parameters estimation to EDAM BAAs and entire EDAM footprint using quantile regression model for DAM trading day
- Extend DAME IRU/IRD demand price curve to EDAM BAAs
- For the WEIM-RSE: treat EDAM pool as a super BAA, calculate the EDAM-pool up and EDAM-pool down FRU/FRD requirement forecast parameters estimation
- Include EDAM pool that passed WEIM-RSE in the passing group
- For the EDAM pool failed WEIM-RSE: break pool into AET/non-AET and calculate FRU/FRD requirement forecast parameters estimation
- Consume and store the EDAM load and VER forecasts 365 days prior to EDAM activation

5.3.1 Business Requirements

ID#	Business Feature	Requirement Type	Potential Application(s) Impacted
EDAM-BRQ-05020	Extend IRUR/IRDR parameters estimates for each EDAM BAA and entire EDAM footprint, broadcast before 6 am of Day-ahead <ul style="list-style-type: none"> • Extend IRUR/IRDR parameters estimates for each EDAM BAA and entire EDAM footprint 	Core DAME The detailed requirements are specified in the DAME BRS	Internal ISO System
EDAM-BRQ-05050	Extend calculation of hourly IRU/IRD demand price curve for IRU and IRD for each BAA using latest (9 am) forecast of Day-ahead <ul style="list-style-type: none"> • Consume the hourly demand, solar and wind forecast at 9 am for DAM time horizon, aggregated for each BAA. • Calculate IRU/IRD demand price curve for each hour interval for each BAA in the EDAM Area • Broadcast IRU and IRD demand price curve after 9 am and before 10 am Demand price curve is for IFM, the DA-RSE uses penalty cost for IRUR/IRDR	Core DAME The detailed requirements are specified in the DAME BRS DAME-BRQ-02320	Internal ISO System
EDAM-BRQ-05060	FRUR/FRDR parameters estimates for each 15min interval of the Trading Hour (TH) for EDAM BAAs up/down pools for	Core	Internal ISO System

 California ISO	Technology	Template Version:	6.8
		Document Version:	4.61.7
Extended Day Ahead Market Business Requirements Specification - Planning		Date Created:	1/21/2026

ID#	Business Feature	Requirement Type	Potential Application(s) Impacted
	<p>WEIM RSE at TH-5hr, only when EDAM pool, AET/non-AET sub-pool composition has changed</p> <ul style="list-style-type: none"> System consumes from SIBR the EDAM up/down pools associated BAAs System estimates parameters by using the pooled BAAs historical uncertainty data. System will always regress and calculate the second order polynomial coefficients data for the pool of EDAM BAAs as a super BAA Merge 15min net demand/solar/wind data adjusted forecast uncertainty and advisory forecast for the trading hour in the Data Retention Period for the Day Type of the Trading Day of the trading Hour for the group of BAAs in the EDAM pool Calculate net load high/low (P99/1) threshold, calculate Histogram (P97.5/2.5) and the second-order polynomial coefficients ($A_{15}^{P97.5/2.5}, B_{15}^{P97.5/2.5}, C_{15}^{P97.5/2.5}$) of the High/Low Percentile quadratic quantile regression of demand, solar, wind and net load, and MOSAIC for EDAM pool 	FRP deliverability BRS	
EDAM-BRQ-05062	<p>FRUR/FRDR parameters estimates for the passed group that include BAAs in EDAM pool that passed WEIM-RSE at TH-40</p> <ul style="list-style-type: none"> If EDAM pool as super BAA passed the WEIM-RSE, all the BAAs in EDAM pool will be part of the passing group. Parameter estimation for the passed group shall apply. 	Existing FRP deliverability BRS	Internal ISO System
EDAM-BRQ-05070	<p>FRUR/FRDR parameters estimates for each 15min/5min interval of Trading Hour (TH) for AET sub-pool and non-AET sub-pool formed at TH-5hr, only when EDAM pool, AET/non-AET sub-pool composition has changed Consume the EDAM BAA AET sub-pool and non-AET sub-pool and associated group of BAAs for the trading hour</p> <ul style="list-style-type: none"> Merge 15min net demand/solar/wind data adjusted forecast uncertainty and advisory forecast for the trading Hour in the Data Retention Period for the Day Type of the Trading Day of the trading Hour for group of BAAs in AET sub-pool and Non-AET sub-pool Calculate net load high/low (P99/1) threshold, calculate Histogram (P97.5/2.5) and the second-order polynomial coefficients ($A_{15}^{P97.5/2.5}, B_{15}^{P97.5/2.5}, C_{15}^{P97.5/2.5}$) of the High/Low 	Core	Internal ISO System

 California ISO	Technology	Template Version:	6.8
		Document Version:	4.6 1.7
Extended Day Ahead Market Business Requirements Specification - Planning		Date Created:	1/21/2026

ID#	Business Feature	Requirement Type	Potential Application(s) Impacted
	Percentile quadratic quantile regression of demand, solar, wind and net load, and MOSAIC for each sub-pool		
EDAM-BRQ-05075	<p>FRUR/FRDR parameters estimates every Hour (TH) of trading day for EDAM pool upward/downward and AET sub-pool and non-AET sub-pool formed at the time DAM result posted, only when EDAM pool, AET/non-AET sub-pool composition has changed</p> <ul style="list-style-type: none"> • Consume IFM and RUC PBC surplus variable values for each EDAM BAA from market for each hour • Consume the BAA AET options from MF • Form the EDAM pool composition: <ul style="list-style-type: none"> ○ The EDAM BAAs that have the PBC surplus variable non positive values composite the EDAM Upward pool ○ The EDAM BAAs that have the PBC surplus variable nonnegative values composite the EDAM downward pool ○ The BAAs in EDAM Upward pool that option AET form the AET sub-pool ○ The BAAs in EDAM Upward pool that option non-AET form the non-AET sub-pool • Use same method to estimate FRUR/FRDR parameters every Hour (TH) of trading day for the EDAM upward pool, downward pool, AET sub-pool and non-AET sub-pool • Broadcast 15min interval of each hour's Histogram, second-order polynomial coefficients, net load uncertainty threshold for each pool and sub-pool <p>Note: This process will conduct right after DAM is finished therefore give the EDAM entity advisory FRP parameters right after DAM.</p>	Core	Internal ISO System
EDAM-BRQ-05080	<p>System shall consume and store EDAM VER and load DAM forecast data prior to EDAM activation</p> <ul style="list-style-type: none"> • Consume/store trading day of DAM load, wind, solar forecast for EDAM BAA data in retention period (default 365 days), broadcasted from the market before the activation of EDAM 	Core	Internal ISO System

 California ISO	Technology	Template Version:	6.8
		Document Version:	6.1.7
Extended Day Ahead Market Business Requirements Specification - Planning		Date Created:	1/21/2026

ID#	Business Feature	Requirement Type	Potential Application(s) Impacted
EDAM-BRQ-05085	Extend FRUR/FRDR parameters estimates for EDAM footprint and AET / Non-AET sub-pool for 24 hours, broadcast after 6am in Day-ahead <ul style="list-style-type: none"> Extend FRUR/FRDR parameters estimates for EDAM area from 15min interval data Extend FRUR/FRDR parameters estimates for AET / Non-AET sub-pool from 15min/ 5min interval data 	Core	Internal ISO System

 California ISO	Technology	Template Version:	6.8
		Document Version:	6.1.7
Extended Day Ahead Market Business Requirements Specification - Planning		Date Created:	1/21/2026

5.4 Business Process: Manage Resource Adequacy

Support RA-eligible imports into the CAISO from EDAM BAAs, WEIM BAAs, and BAAs outside both the EDAM and WEIM footprints.

- 1) In the month-ahead RA showing: the RA provider SC shall define a generic System Resource (SR) sourced at its registered SP-Tie (for Generic RA only) and/or a TG sourced an associated Physical Resource located at the BAA source (for Flex and Generic RA) and show their RA obligation at this SR (no physical resource declaration required).
 - a) SC must have adequate MIC for the Tie that supports the RA showing.
- 2) Scenario 1a – SR is located within an EDAM BAA: in DA the SC reassigns its RA obligation from the SR to physical resource(s) by 8:00 am, and obligation remains on physical resources for RT.
 - a) The RA obligation may be reassigned to resources represented by the same or different SC(s).
 - b) RAAIM will be assessed at the resource where the RA obligation is reassigned in DAM and RTM.
 - i) If resource is scheduled in DA, the entire RA obligation applies to RTM.
 - ii) If resource is not scheduled in DA, there is no RTM RA obligation.
- 3) Scenario 1b – TG is located within an EDAM BAA: in DA the SC reassigns its RA obligation from the TG to physical resource(s) by 8:00 am, and obligation remains on physical resources for RT.
- 4) Note: No changes to current process for RA Imports sourced in WEIM and non-WEIM BAAs for EDAM Day 1

5.4.1 Business Requirements

ID#	Business Feature	Requirement Type	Potential Application(s) Impacted
EDAM-BRQ-07100	Define SP-Tie SRs for RA provider SCs to define RPS or RA Obligation in Month-Ahead showings process <ul style="list-style-type: none"> • Allow RA providers importing into the CAISO to register SRs sourced at their SP-Tie • SR shall not be eligible to bid in the EDAM/DAM or RTM/WEIM • SRs may be ITIEs or non-resource specific TGs • SP-Tie SRs shall not be eligible for IR/RC awards (and therefore are not eligible for overlapping RA transitional measures). 	Process	MF
EDAM-BRQ-07100a	Define resource-specific TGs for RA provider SCs to define RPS or RA Obligation in Month-Ahead showings process for Flex RA <ul style="list-style-type: none"> • Allow RA providers importing into the CAISO to register TGs to support Flex RA showings 	Process	MF

 California ISO	Technology	Template Version:	6.8
		Document Version:	6.1.7 1.7
Extended Day Ahead Market Business Requirements Specification - Planning		Date Created:	1/21/2026

ID#	Business Feature	Requirement Type	Potential Application(s) Impacted
EDAM-BRQ-07100b	<p>Allow RA Provider SC to Register SRs at CISO EDAM Transfer Locations when the RA Import Source is outside the EDAM footprint or is unknown</p> <ul style="list-style-type: none"> • These SRs (ITIE or TG) shall be allowed to bid into DAM, HASP, and RT <ul style="list-style-type: none"> ◦ The submission of bids on these SRs shall serve as the SC's confirmation the source is outside of the EDAM footprint or is unknown • These SRs shall not reassign their RA to a physical resource before the DAM 	Process	MF
EDAM-BRQ-07100d	<p>Define Exception MSR at CISO EDAM Transfer Locations during the EDAM transitional period to support RA Imports from SRs for which the source is outside the EDAM footprint or is unknown</p> <ul style="list-style-type: none"> • These MSRs shall only be used by RA Imports as defined in EDAM-BRQ-07100b <p>Note: These MSRs shall have NO base schedules as they are located in EDAM BAAs, they will receive full settlements and therefore the EDAM Entity will need to sub-allocate their settlements to the transmission customer SCs</p>	Process	MF
EDAM-BRQ-07103	<p>Allow RA Supplier to Define Month-Ahead RA Obligation at SP-Tie SR</p> <ul style="list-style-type: none"> • At the time of RA showing, allow importing RA Supplier (Resource SC) to define their RA obligation at their MF-defined SP-Tie SR • RA supplier may only show generic RA at the SP-Tie SR 	Existing	CIRA
EDAM-BRQ-07103a	<p>For Flex RA: allow RA Supplier to Define Month-Ahead RA Obligation at a TG sourced from an EDAM BAA</p> <ul style="list-style-type: none"> • At the time of RA showing, allow importing RA Supplier (Resource SC) to define their RA obligation at their MF-defined TG 	Existing	CIRA

 California ISO	Technology	Template Version:	6.8
		Document Version:	6.1.7
Extended Day Ahead Market Business Requirements Specification - Planning		Date Created:	1/21/2026

ID#	Business Feature	Requirement Type	Potential Application(s) Impacted
	<ul style="list-style-type: none"> RA supplier may show Flex RA and/or Generic RA at the TG 		
EDAM-BRQ-07103b	No impacts to RA process for Pseudo-Tie Resources <ul style="list-style-type: none"> TG RA Obligation reassignment rules shall not apply to Pseudo-Tie resources 	Core	CIRA
EDAM-BRQ-07104	Validate that RA Month-Ahead showing at SP-Tie SR has adequate MIC <ul style="list-style-type: none"> The system shall validate that the month-ahead RA showing amount on the SP-Tie SR does not exceed the MIC procured by the SC at the intertie associated with the SP-Tie SR Reject all MW showings that exceed the procured MIC and provide notification to SC of submission rejection Note: SP-Tie SRs will be modeled as ITIEs in MF 	Existing	CIRA
EDAM-BRQ-07104a	Validate that RA Month-Ahead showing at TG has adequate MIC for Generic RA and adequate EFC for Flex RA <ul style="list-style-type: none"> The system shall validate that the month-ahead RA showing amount of Generic RA on the TG does not exceed the MIC procured by the SC at the intertie associated with the TG The system shall validate that the month-ahead RA showing amount of Flex RA on the TG does not exceed the EFC procured by the SC at the intertie associated with the TG Reject all MW showings that exceed the procured MIC and provide notification to SC of submission rejection 	Existing	CIRA
EDAM-BRQ-07105	Timing Requirements for RA Obligation Reassignments: <ul style="list-style-type: none"> Month-Ahead Showings: no change to existing submission timing 	Core	CIRA

 California ISO	Technology	Template Version:	6.8
		Document Version:	4.6 1.7
Extended Day Ahead Market Business Requirements Specification - Planning		Date Created:	1/21/2026

ID#	Business Feature	Requirement Type	Potential Application(s) Impacted
	<ul style="list-style-type: none"> • DA RA Obligation Reassignments (values shall be configurable): <ul style="list-style-type: none"> ○ Start: T-28 ○ End: 8:00 am for the DAM run 		
EDAM-BRQ-07105a	<p>Reassignment logic in DA: The RA reassignment applies for the entire month</p> <ul style="list-style-type: none"> • RA obligation reassignments made by the SC shall apply to the entire month, unless otherwise specified by the SC. • The SC shall be able to cancel reassignments for future TDs that have not had the DAM run for that TD <p>Note: SCs retain the flexibility to adjust reassignment on any day, and the system will honor those changes for the rest of the month.</p>	Core	CIRA
EDAM-BRQ-07106	<p>For EDAM SP-Tie SRs: RA Supplier to Reassign RA Obligation from SP-Tie SR to EDAM Physical Resource(s) in DA</p> <ul style="list-style-type: none"> • For EDAM SP-Tie SRs with Month-Ahead RA showings, the SC shall reassign the RA MW allocation from the SP-Tie SR to physical resource(s) before the applicable DAM run <ul style="list-style-type: none"> ○ The RA obligation may be reassigned to resources represented by the same or different SC(s) <ul style="list-style-type: none"> ▪ Apply 3rd party SC approval rules like today • RA obligation shall remain on the physical resource(s) for RT • If the source of the RA Import SR is not located in an EDAM BAA or is not known (as defined in EDAM-BRQ-07100b), the SC shall NOT reassign to physical resources <p>Note: Only resource SCs shall be able to access the RA reassignment UI</p>	Core	CIRA

 California ISO	Technology	Template Version:	6.8
		Document Version:	6.1.7
Extended Day Ahead Market Business Requirements Specification - Planning		Date Created:	1/21/2026

ID#	Business Feature	Requirement Type	Potential Application(s) Impacted
EDAM-BRQ-07106a	<p>For EDAM TGs: RA Supplier to Reassign RA Obligation from Generic TG to EDAM physical resource(s) in DA</p> <ul style="list-style-type: none"> • For EDAM TGs with Month-Ahead RA showings, the SC shall reassign the RA MW allocation from the TG to physical resource(s) before the applicable DAM run <ul style="list-style-type: none"> ○ The RA obligation may be reassigned to a resource represented by the same or different SC <ul style="list-style-type: none"> ▪ Apply 3rd party SC approval rules like today • RA obligation shall remain on the physical resource for RT • If the source of the RA Import TG is not located in an EDAM BAA or is not known (as defined in EDAM-BRQ-07100b), the SC shall NOT reassign to physical resources <p>Note: Only resource SCs shall be able to access the RA reassignment UI</p>	Core	CIRA
EDAM-BRQ-07110	<p>For SRs – Validate Pre-DA RA Obligation Reassignments each time a new RA reassignment is submitted:</p> <p>Reject submissions that do not meet the following validation rules and notify the SC of the rejection:</p> <ul style="list-style-type: none"> • Each resource provided in the RA obligation reassignment must have a valid Resource ID • The RA obligation reassignment MW amount for each resource shall not exceed that resource’s UOL • The sum of the RA obligation reassignment MWs may not exceed the total RA Month-Ahead MW showing on the SP-Tie SR <ul style="list-style-type: none"> ○ Any MWs not transferred shall remain on the SP-Tie SR • Validate that the sum of all RA obligation reassignments in DA for each Resource ID does not exceed the resource UOL • If a correct submission is not received by 8:00 am, the entire obligation will remain on the SP-Tie SR (and will 	Core	CIRA

 California ISO	Technology	Template Version:	6.8
		Document Version:	6.8 1.7
Extended Day Ahead Market Business Requirements Specification - Planning		Date Created:	1/21/2026

ID#	Business Feature	Requirement Type	Potential Application(s) Impacted
	be subject to energy imbalance settlements and RAIM in RTM) <ul style="list-style-type: none"> RA obligation may not be reassigned from a SR to a TG 		
EDAM-BRQ-07110a	For TGs – Validate Pre-DA RA Obligation Reassignments each time a new RA reassignment is submitted: Reject submissions that do not meet the following validation rules and notify the SC of the rejection: <ul style="list-style-type: none"> Each resource provided in the RA obligation reassignment must have a valid Resource ID The RA obligation reassignment MW amount for each resource shall not exceed that resource’s UOL The RA obligation reassignment MWs may not exceed the total RA Month-Ahead MW showing on the TG <ul style="list-style-type: none"> Any MWs not transferred shall remain on the TG Validate that the sum of all RA obligation reassignments in DA for each Resource ID does not exceed the resource UOL If a correct submission is not received by 8:00 am, the entire obligation will remain on the TG (and will be subject to energy imbalance settlements and RAIM in RTM) 	Core	CIRA
EDAM-BRQ-07111a	Update MOO Rules for TGs: No Must Offer for Non-Pseudo-Tied TGs <ul style="list-style-type: none"> MOO flag shall be N for non-pseudo-tied TGs sourced at an EDAM BAA with RA obligations for the DAM 	Core	CIRA
EDAM-BRQ-07111b	No Bid Insertion for EDAM SRs or TGs in DAM or RTM <ul style="list-style-type: none"> System shall not insert bids in the DAM for any RA obligation that remains on an SR sourced at an EDAM SP-Tie or non-pseudo-tied TG sourced at an EDAM BAA 	Existing	SIBR
EDAM-BRQ-07112e	Submit hourly block bid for inertia resources EDAM BAA TG	Existing	SIBR

 California ISO	Technology	Template Version:	6.8
		Document Version:	6.8 1.7
Extended Day Ahead Market Business Requirements Specification - Planning		Date Created:	1/21/2026

ID#	Business Feature	Requirement Type	Potential Application(s) Impacted
	Note: EDAM BAA TG are not optimized in FMM and RTD		
EDAM-BRQ-07113	DA Third-Party SC Notification and Approval Process <ul style="list-style-type: none"> • When a SC reassigns an RA obligation to a resource represented by a different SC, the system shall generate an email to notify the SC that they need to approve the RA obligation reassignment to their resource(s) • SC shall be able to approve in CIRA similar to the current substitution SC approval process • DA submission must be approved by 8:00 am 	Core	CIRA
EDAM-BRQ-07115	For Import Capability Reports: Show RA Used on the SRs used for the Month-Ahead Showings process <ul style="list-style-type: none"> • For the Import Capability RA Report Details, for non-CAISO RA showings, the RA showing MW shall report the MW shown on the SR or TG used in the Month-Ahead showing and shall remain locked on this value 	Core	CIRA
EDAM-BRQ-07116	Save and Report on DA RA Obligation Reassignments <ul style="list-style-type: none"> • Store the original SP-Tie SR and TG Resource ID and MW amount used in the Month-Ahead showing • For all DA RA obligation reassignments: store the Resource IDs and associated MW values that received a RA obligation reassignment • Report Month-Ahead RA showings and the associated DA RA Obligation reassignments to the CPUC 	Core	CIRA
EDAM-BRQ-07125	Assess RAAIM for RA Imports <ul style="list-style-type: none"> • RAAIM will be assessed at the resource where the RA obligation is reassigned in DAM <ul style="list-style-type: none"> ○ Any MW not reassigned remains on the SP-Tie SR or SP TG ○ Any MW not reassigned to a physical resource per the DA RA obligation reassignment rules is susceptible to RAAIM penalties for the applicable market 	Core	Settlements

 California ISO	Technology	Template Version:	6.8
		Document Version:	6.1.7
Extended Day Ahead Market Business Requirements Specification - Planning		Date Created:	1/21/2026

ID#	Business Feature	Requirement Type	Potential Application(s) Impacted
EDAM-BRQ-07125a	Assess RAIM independently for all resources that have DAM Ahead Obligation	Core	Settlements
EDAM-BRQ-07135	RA Suppliers/Resource SCs shall report outages on the resource that has the RA obligation showing/reassignment at the time of the outage submission	Participant Core	WebOMS
EDAM-BRQ-07137	Real-Time and Forced Substitution Rules for Physical Resources <ul style="list-style-type: none"> Resources that do not have MIC and are not on the NQC list cannot be used for substitution Apply RASC per current process 	Existing	CIRA

 California ISO	Technology	Template Version:	6.8
		Document Version:	4.6 1.7
Extended Day Ahead Market Business Requirements Specification - Planning		Date Created:	1/21/2026

5.5 Business Process: Manage Default Energy Bids

- Calculate/broadcast DEB, DAB, and GHG cost for EDAM resources
- Update GMC

5.5.1 Business Requirements

ID#	Business Feature	Requirement Type	Potential Application(s) Impacted
EDAM-BRQ-08010	Extend DEB and reasonableness threshold DEB to EDAM resources <ul style="list-style-type: none"> • Provide DEB and reasonableness threshold DEB for all resources in all EDAM BAAs, by default, all the resources in the EDAM BAA • Maintain existing logic when determining which resources the system shall calculate a DEB for • Include appropriate GHG cost for resources located within a GHG area (i.e. WA GHG cost for resources in WEIM WA GHG Area, CA GHG cost for resources in CA GHG area) 	Existing	Internal ISO System
EDAM-BRQ-08018	Use the CAISO BAA MEC in the calculation of the Maximum Import Bid Price (MIBP)	Existing	Internal ISO System
EDAM-BRQ-08020	Determine maximum GHG Bid adder Eligibility <ul style="list-style-type: none"> • Calculate maximum GHG bid adder for resources when the following conditions are met: <ul style="list-style-type: none"> ○ Resource is not located within a GHG regulation area <p>Note: Maximum GHG Bid adder=GHG bid cap</p>	Core	Internal ISO System
EDAM-BRQ-08030	Calculate Resource maximum GHG bid adders for resources to serve load in EDAM GHG regulation areas <ul style="list-style-type: none"> • Maximum bid adders shall be specific to each GHG regulation area (i.e. one set of maximum bid adders for each GHG regulation area) <ul style="list-style-type: none"> ○ Use existing calculation methodology—use same external feeds as today ○ Use WA GHG allowance price for WA, and CA GHG allowance price for CA 	Core	Internal ISO System

 California ISO	Technology	Template Version:	6.8
		Document Version:	6.1.7
Extended Day Ahead Market Business Requirements Specification - Planning		Date Created:	1/21/2026

ID#	Business Feature	Requirement Type	Potential Application(s) Impacted
	<ul style="list-style-type: none"> ○ A resource can serve multiple GHG regulation areas, so can have multiple maximum GHG bid adders. 		
EDAM-BRQ-08040	<p>Include System Operations Real-Time Dispatch charge rate in variable cost-based DEBs for EDAM and CAISO resources</p> <ul style="list-style-type: none"> • Consume System Operations Real-Time Dispatch rate defined in MF • Variable Cost-based DEBs for CAISO and EDAM resources should include the System Operations Real-Time Dispatch (SYSOPRTD) rate in both the DAM and RTM DEBs • For WEIM only: continue to use WEIM rate (ESYOPR) for RT <p>Notes:</p> <ul style="list-style-type: none"> • Effective June 1, 2026 • New Cost of Service Initiative breaks the current System Operations GMC charge into two components: <ul style="list-style-type: none"> • System Operations Real-Time Dispatch • System Operations Balancing Authority Area Services 	Core	Internal ISO System
EDAM-BRQ-08050	<p>Extend IRU/IRD, RCU/RCD default availability bid (DAB) to EDAM resources</p> <ul style="list-style-type: none"> • Set configurable IRU/IRD, RCU/RCD default availability bid (DAB) to \$55/MWh 	Core DAME	Internal ISO System
EDAM-BRQ-08060	<p>Obtain, store, and broadcast on-peak bilateral trading Mid-C, PV Hub prices</p> <ul style="list-style-type: none"> • Used for Settlements surcharge for the BAA failed DA-RSE • Broadcast bilateral trading Mid-C, PV Hub prices for DA-RSE deficit penalty calculation • Fallback Logic: If bilateral prices are missing for a given hub on a given TD, use the most recently available price by hub 	Core	Internal ISO System

 California ISO	Technology	Template Version:	6.8
		Document Version:	6.1.7 1.7
Extended Day Ahead Market Business Requirements Specification - Planning		Date Created:	1/21/2026

ID#	Business Feature	Requirement Type	Potential Application(s) Impacted
EDAM-BRQ-08070	Extend existing DEB, reasonableness threshold DEB, and GHG data for EDAM Resources <ul style="list-style-type: none"> • DEB • Reasonableness threshold DEB • GHG startup cost curve • GHG min load cost • GHG energy component • DAB for IRU/IRD, RCU/RCD 	Core DAME	Internal ISO System
EDAM-BRQ-08080	New GHG related data: <ul style="list-style-type: none"> • Most recent Resource maximum GHG bid adders for each GHG area <p>Note for GHG areas: WA and CA may have different maximum GHG bid adders</p>	Core	Internal ISO System
EDAM-BRQ-08132	Prepare GHG price of GHG area <ul style="list-style-type: none"> • GHG area GHG price (GHGasm-1) for the previous month, average greenhouse gas allowance price from prior month • GHG area GHG price (GHGast, y-1) for the previous year, average greenhouse gas allowance price from prior year. • GHG area GHG price (GHGasm-12) for the monthly average greenhouse gas allowance price from the previous year's period, m-12 	Existing	Internal ISO System
EDAM-BRQ-08135	Expand existing WEIM negotiated DEB (NDEB) calculations to EDAM entities <ul style="list-style-type: none"> • Extend negotiation, testing, implementation, and production of NDEBs to EDAM entities • No changes to existing WEIM entity NDEBs • Broadcast EDAM NDEBs to downstream systems <p>Note- Business Process: DMM shall reach out to new EDAM entities with existing WEIM NDEBs to confirm/renegotiate DAM NDEB</p>	Core	Internal ISO System

 California ISO	Technology	Template Version:	6.8
		Document Version:	6.1.7
Extended Day Ahead Market Business Requirements Specification - Planning		Date Created:	1/21/2026

5.6 Business Process: Manage Bid Submission and TSR Submission (SIBR, TSR submission)

- Facilitate EDAM resource bid submission in SIBR to participate the DAM market, similar to ISO resources
- Facilitate the DA TSR schedule and limits submission, with MF defined attribution for RSE, and deemed pathway for TSR with CRN in SIBR
- Facilitate late schedule for CRN through RTSI
- Facilitate EDAM BAA AS requirements in SIBR
- Facilitate dynamically formed DA TSR ID in SIBR
- Allow transaction ID location at DGAP or super DGAP
- Facilitate EDAM entity, on behalf of transmission right owner, to submit new CRN entitlement for each sale by 9 am in DAM, and by TH-90 min in RTM
- Allow SC of resources that sell CRN to submit self-schedules associated with corresponding new CRN in the DAM or RTM

5.6.1 Business Requirements

ID#	Business Feature	Requirement Type	Potential Application(s) Impacted
EDAM-BRQ-11000	EDAM resources participate in DAM market, similar to ISO resources General statement: DAM validation rules for CAISO apply to EDAM	Business Process	SIBR
EDAM-BRQ-11010	Access Master file definition and association for EDAM: <ul style="list-style-type: none"> • EDAM entity, EDAM BAA and EDAM/WEIM entity SC and resource SC definition and association 	Core	SIBR (from MF)
EDAM-BRQ-11011	Access EDAM BAA Convergence Bidding participation flag from Master file <ul style="list-style-type: none"> • Access EDAM BAA CB participation flag • Access registered location, position limit, nodal constraint that are applicable for the EDAM BAA that elect CB 	Core	SIBR (from MF)
EDAM-BRQ-11012	Access resource eligibility flags Access EDAM resource participation, RSE flag and eligibility flags on market product EN/AS/IR/RC from Master File, in the same manner as ISO resources	Core	SIBR (from MF)

 California ISO	Technology	Template Version:	6.8
		Document Version:	6.1.7
Extended Day Ahead Market Business Requirements Specification - Planning		Date Created:	1/21/2026

ID#	Business Feature	Requirement Type	Potential Application(s) Impacted
EDAM-BRQ-11013	Access intertie resource eligibility flags Access intertie resources an, RSE flag, bid eligible flags for bids, or self-schedule only from Master File	Core	SIBR (from MF)
EDAM-BRQ-11015	Access GHG area and associated resources Access the defined GHG area, mapping of resources associated with the GHG area, the CLAP associated with the GHG area, GHG pseudo tie flag from Master File, and resources that are dynamically scheduled into a BAA that overlaps with a GHG regulation area	Core	SIBR (from MF)
EDAM-BRQ-11020	Allow EDAM LSE SC to submit non-participating load resource bids <ul style="list-style-type: none"> • Allow EDAM LSE SC to submit non-participating load resource bids modeled with up to 10 segments monotonically decreasing for EDAM BAAs, same as demand resource bids for ISO BAAs Note: The Participating Load in the CAISO Markets, like Generation by submitting Supply Bids when offering Curtailable Demand and as non-Participating Load by submitting Demand Bids, are to be consumed in the Day-Ahead Market only	Existing	SIBR
EDAM-BRQ-11030	Extend energy and commitment bidding rules found in DAME for supply resource hourly bids and/or Self-Schedule (SS) to EDAM Note: For the determination of Proxy Start-Up Costs, Proxy Transition Cost and Proxy Minimum Load Costs (and associated Default and Reasonableness Threshold values), the CAISO will utilize the Market Services Charge and System Operations Charge reflected in the EDAM Administrative Charge defined in MF	Core DAME	SIBR
EDAM-BRQ-11040	Extend ISO DAME rules for eligible resources to submit resource DAM hourly IR/RC bids to EDAM	Core DAME	SIBR
EDAM-BRQ-11050	Extend Resource SC of ISO to submit hourly Energy, IR/RC bids for Dynamic and Pseudo-tie resources to EDAM	Core DAME	SIBR

 California ISO	Technology	Template Version:	6.8
		Document Version:	4.61.7
Extended Day Ahead Market Business Requirements Specification - Planning		Date Created:	1/21/2026

ID#	Business Feature	Requirement Type	Potential Application(s) Impacted
EDAM-BRQ-11054	<p>Include ISO Scheduling Point (SP) associated to non-EDAM DGAP in Transaction ID</p> <ul style="list-style-type: none"> • Access MF defined eligible SP for ISO and SP to DGAP association. The SP has one-on-one association with DGAP or SDGAP for Transaction ID. • Access MF defined DGAP-TIE, SDGAP-TIE mapping • Access MF defined TIE-ITC mapping • Allow SC to submit transaction ID applicable attributes for import/export between ISO and non-EDAM BAAs, same as current process. <ul style="list-style-type: none"> ○ The transaction ID attributes include the location (DGAP/SDGAP/cnode), ○ Pick the intertie that is associated with the SP that the transaction ID resource is scheduled on • Intertie Transactions for import/export schedules at CISO Scheduling Points from/to non-EDAM BAAs in DAM will specify the DGAP of the source/sink non-EDAM BAA 	Core	SIBR
EDAM-BRQ-11054a	<p>Support ISO transaction ID associated to non-EIM BAA DGAP in RTM</p> <ul style="list-style-type: none"> • Intertie Transactions for import/export schedules at CISO Scheduling Points from/to non-EIM BAAs in RTM will specify the DGAP of the source/sink non-EIM BAA 	Core	SIBR
EDAM-BRQ-11055	<p>Support Transaction ID for EDAM intertie import/export resource between EDAM BAA and Non-EDAM BAA</p> <ul style="list-style-type: none"> • Allow EDAM SC to submit attributes to form transaction ID as import/export between EDAM BAA and non-EDAM BAAs <ul style="list-style-type: none"> ○ Same as ISO intertie transaction ID, attributes include: SCID, Location ID, SP, Direction, bid type, intertie ID, Energy Type, PSE ○ Extending rule for ISO transaction ID to EDAM transaction ID- • The transaction ID that include the SP with association to non-EDAM DGAP or Super DGAP (SDGAP) will use DGAP or SDGAP as injection location in the market 	Core	SIBR

 California ISO	Technology	Template Version:	6.8
		Document Version:	6.1.7
Extended Day Ahead Market Business Requirements Specification - Planning		Date Created:	1/21/2026

ID#	Business Feature	Requirement Type	Potential Application(s) Impacted
	<ul style="list-style-type: none"> For the transaction ID for which the non-EDAM BAA is WEIM BAA, WEIM BAA shall register mirror resource in MF and submit the Mirror schedule base schedule in RTM Support for new System Resources or Intertie Transactions for import/export schedules at EDAM interties from/to non-EDAM BAAs in DAM at the source/sink BAA Existing System Resources and support for Intertie Transactions for import/export schedules at EIM interties from/to non-EIM BAAs in RTM at the source/sink BAA DGAP will be preserved 		
EDAM-BRQ-11055a	<p>Do not support transaction ID between EDAM BAAs, between WEIM BAAs.</p> <ul style="list-style-type: none"> No support for System Resources or Intertie Transactions for import/export schedules at CISO Scheduling Points from/to EDAM BAAs in DAM; EDAM Transfers will be used instead No support for System Resources or Intertie Transactions for import/export schedules at CISO Scheduling Points from/to EIM BAAs in RTM; Dynamic Transfers will be used instead 	Core	SIBR
EDAM-BRQ-11058	<p>WEIM entity shall submit base schedule as mirror for DA schedule with EDAM BAA</p> <ul style="list-style-type: none"> Any DA import/export schedule from/to an EIM BAA to/from an EDAM BAA must be mirrored in the WEIM with an export/import MSR at the same location (the EIM BAA DGAP). If a SDGAP is used, the schedule must be bought back in RTM and replaced with either resource schedules in an EDAM/WEIM BAA (they can be base schedules in an WEIM BAA) or import/export schedules at a non-WEIM DGAP. MSR base schedules may continue to be updated by the WEIM Entity SC to match any DA schedule changes in RTSI up until T-40 	Core	BSAP
EDAM-BRQ-11059	<p>For the DA schedule using SDGAP, enforce buy back in RTM</p>	Core	SIBR

 California ISO	Technology	Template Version:	6.8
		Document Version:	6.1.7
Extended Day Ahead Market Business Requirements Specification - Planning		Date Created:	1/21/2026

ID#	Business Feature	Requirement Type	Potential Application(s) Impacted
	<ul style="list-style-type: none"> • For the DA schedule between EDAM BAA and non-EDAM BAA that use SDGAP, the schedule must be bought back in RTM <ul style="list-style-type: none"> ○ Set the DA schedule at 0 in RTM • The SC of the DA schedule can replace by submitting self-schedule where the source/sink at BAA actual location using DGAP 		
EDAM-BRQ-11060	<p>Support EDAM system resource (SR) self-schedule Energy, continue to support ISO inertia SR bids</p> <ul style="list-style-type: none"> • Continue existing energy economic bids or self-schedule at ISO interties between the ISO BAA and non-EDAM BAAs • Allow EDAM resource SC to submit self-scheduled energy for import/export resource, include transaction ID resource between EDAM BAA and non-EDAM BAAs • Self-schedule import/export with RSE flag will be counted in DA-RSE <ul style="list-style-type: none"> ○ Import/export resource must be defined in MF with RSE flag • Other self-schedule import/export, without RSE flag defined in MF, will not counted be in RSE • Transaction ID shall not be RSE eligible 	Core	SIBR
EDAM-BRQ-11070	<p>Allow eligible EDAM OATT network resource economic bids for energy, IRU/IRD, RCU/RCD</p> <ul style="list-style-type: none"> • Access EDAM BAA's network resource under OATT defined in MF as TG), RSE flag and eligibility flags from MF • Allow resource submitted economic bids for energy, IRU/IDR, RCU/RCD if eligible • OATT network resource with RSE flag shall be counted in DA-RSE 	Core	SIBR
EDAM-BRQ-11080	<p>Support EDAM MF defined system resource (SR) as eligible resource self-provision AS</p> <ul style="list-style-type: none"> • Continue ISO existing AS economic bids or self-provision AS at ISO inertia between the ISO BAA and non-EDAM BAAs 	Core	SIBR

 California ISO	Technology	Template Version:	6.8
		Document Version:	6.1.7
Extended Day Ahead Market Business Requirements Specification - Planning		Date Created:	1/21/2026

ID#	Business Feature	Requirement Type	Potential Application(s) Impacted
	<ul style="list-style-type: none"> Allow EDAM resources to submit self-provision for AS for import/export resource between EDAM BAA and non-EDAM BAAs. Only MF defined resources and TG resources that are eligible for AS can submit self-provision AS. Only AS self-provision is allowed, no AS economic bid for other non-ISO EDAM BAAs. 		
EDAM-BRQ-11090	Support eligible ISO intertie system resource economic bids for IRU/IRD, RCU/RCD <ul style="list-style-type: none"> Allow MF defined eligible system resources between ISO and non-EDAM BAAs submit IRU/IRD and/or RCU/RCD economic bids <ul style="list-style-type: none"> Transaction ID resource is not eligible for IRU/IRD, RCU/RCD Do not allow self-schedule for IRU/IRD, RCU/RCD 	Core	SIBR
EDAM-BRQ-11092	Support eligible EDAM BAA network resource economic bids <ul style="list-style-type: none"> Allow MF defined network resource (modeled as TG) between other EDAM BAA and non-EDAM BAA that are eligible for IRU/IRD, RCU/RCD to submit economic bids 	Core	SIBR
EDAM-BRQ-11099	System shall consume Resource maximum GHG bid adders	Core	SIBR
EDAM-BRQ-11100	GHG Bid submission and validation <ul style="list-style-type: none"> Allow Resources outside of the GHG area to submit separate GHG hourly bids (≥ 0) for each GHG regulation area GHG pseudo-tie shall not submit GHG bids for the area it is pseudo-tie to. They can submit GHG bid for other GHG area Energy bid range must be equal to or exceed the GHG bid MW 	Core	SIBR
EDAM-BRQ-11100a	Submit GHG hourly contract obligated resource capacity for GHG area	Core	SIBR

 California ISO	Technology	Template Version:	6.8
		Document Version:	6.1.7 1.7
Extended Day Ahead Market Business Requirements Specification - Planning		Date Created:	1/21/2026

ID#	Business Feature	Requirement Type	Potential Application(s) Impacted
	<ul style="list-style-type: none"> Allow Resources outside of the GHG area to submit separate GHG hourly contractually obligated capacity for each GHG regulation area Energy bid range must be equal to or exceed the contractually obligated capacity <p>Note: hourly contract obligated resource capacity for DAM and RTM</p>		
EDAM-BRQ-11101	Maximum GHG Bid Adder <ul style="list-style-type: none"> Apply the GHG regulation area specific maximum GHG bid adder 	Core	SIBR
EDAM-BRQ-11102	Enforce the Bid Cap for Energy bid plus GHG bid <ul style="list-style-type: none"> For each GHG bid for each GHG area: the sum of the GHG Bid Adder price and the Energy Bid price may not exceed the Soft Energy Bid Cap, unless the sum of a resource's maximum GHG bid adder and <i>revised</i> Default Energy Bid exceeds the Soft Energy Bid Cap <ul style="list-style-type: none"> In this case, the sum of a resource's GHG Bid Adder and Energy Bid price may not exceed the sum of the maximum GHG bid adder and the resource's revised Default Energy Bid or the Hard Energy Bid Cap, whichever is lower A revised default energy bid is the result of a manual (via ECIC) or automated (via SIBR) reference level change request <p>Notes:</p> <ul style="list-style-type: none"> This supersedes the existing rule that the sum of the EIM GHG bid adder and energy bid may not exceed the soft offer cap This is a validation rule (bid becomes invalid when limit is exceeded), not a capping rule <p>For all examples below: -Soft offer cap=\$1000 Hard offer cap=\$2000 -Resource has maximum GHG bid cap of \$30 to serve load in CA</p>	Core	SIBR

 California ISO	Technology	Template Version:	6.8
		Document Version:	4.6 1.7
Extended Day Ahead Market Business Requirements Specification - Planning		Date Created:	1/21/2026

ID#	Business Feature	Requirement Type	Potential Application(s) Impacted
	-Resource has maximum GHG bid cap of \$50 to serve load in WA Example 1 - No reference level change request submitted: If resource submits a bid for only CA, the energy bid is limited to \$970. If the resource submits a bid for CA and WA or only WA, the energy bid is limited to \$950. Example 2: Resource submits revised DEB of \$1200: If resource submits a bid for only CA, the energy bid is limited to \$1200. Example 3: Resource submits revised DEB of \$1990: If resource submits a bid for only CA, the energy bid is limited to \$1970.		
EDAM-BRQ-11103	Broadcast resource GHG bids <ul style="list-style-type: none"> Broadcast resource GHG bids for each GHG regulation area as a part of clean bid 	Core	SIBR
EDAM-BRQ-11106	Broadcast All CRN MW Entitlements System shall broadcast all CRN MW entitlements with their respective self-schedules at CRN granularity (either parent or sub) after Day-Ahead and Real-Time Market close. <ul style="list-style-type: none"> 0...1 CRN entitlement limits associate with 1 self-schedule. 	Core	SIBR
EDAM-BRQ-11110	Allow Resource to submit bids to support DA RSE <ul style="list-style-type: none"> Resource SC shall submit updated bids or self-schedule to support DA RSE between 6 am to 10 am Note: Allow all RSE resource energy bids or self-schedule counted in RSE Allow all RSE resource IRU/IRD bids counted in RSE	Core	SIBR
EDAM-BRQ-11112	Broadcast updated resource bids to support advisory and binding RSE between 6 am and 10 am	Core	SIBR

 California ISO	Technology	Template Version:	6.8
		Document Version:	4.6 1.7
Extended Day Ahead Market Business Requirements Specification - Planning		Date Created:	1/21/2026

ID#	Business Feature	Requirement Type	Potential Application(s) Impacted
	<ul style="list-style-type: none"> SIBR broadcast all resource available bids at least every 30 minutes between 6 am and 10 am to support DA-RSE 		
EDAM-BRQ-11120	Consume Resource Convergence bids (CB) <ul style="list-style-type: none"> Access MF EDAM CB option Allow SC to submit resource convergence bids (CB) for the BAA that option-in CB, (currently only ISO) The CB bids are subject to suspension or limitation 	Core	SIBR
EDAM-BRQ-11130	EDAM entity, or SC designated by the EDAM Entity, shall submit AS requirements: <ul style="list-style-type: none"> EDAM entity SC, <u>or SC designated by the EDAM Entity,</u> shall submit AS (Regulation Up/Down, Spin/NSpin) requirements of EDAM BAA System shall continue to use ASRS for ISO AS requirements 	Core	SIBR AIM
EDAM-BRQ-11210	Resource energy and capacity bid into IFM must bid in RCU; the economic energy bid must cover the range of capacity bids For all resources in EDAM (including CAISO BAA): <ul style="list-style-type: none"> For all physical supply resources, except VERs, energy and capacity bid into the IFM is also bid into the RCU The system shall insert RCU capacity bids if not included with an Energy bid (economic curve) for any resource certified for RCU Note: <ul style="list-style-type: none"> VER capacity extend to forecast in RUC for RCU - market requirement VER capacity extend to forecast in RSE – RSE requirement 	Core DAME	SIBR
EDAM-BRQ-11220	RTM must offer obligation (MOO) for EDAM awards <ul style="list-style-type: none"> All Energy, AS, imbalance reserve and reliability capacity awards in the EDAM have a must offer obligation in the WEIM in RTM, must bid energy to cover the awards range If resource does not bid EDAM, award in RTM 	Core DAME)	SIBR

 California ISO	Technology	Template Version:	6.8
		Document Version:	6.1.7
Extended Day Ahead Market Business Requirements Specification - Planning		Date Created:	1/21/2026

ID#	Business Feature	Requirement Type	Potential Application(s) Impacted
	<ul style="list-style-type: none"> ○ DAM energy award will be self-scheduled minus IRD minus RCD ○ Extend the DEB to cover the range of AS and IR and RC awards <p>Ex: IFM EN=50 MW, IRU=10MW, IRD=10MW, RTM: SS 40 MW, bids for 40 MW to 60 MW</p>		
EDAM-BRQ-11230	<p>EDAM entity shall not submit base schedules in WEIM</p> <ul style="list-style-type: none"> • An EDAM Entity will not submit WEIM Base Schedules. Instead, the Day-Ahead Schedules for the EDAM Entity Balancing Authority Area will be used for the WEIM Entity Balancing Authority Area in the Real-Time Market 	Core	BSAP
EDAM-BRQ-11270	<p>SC of associated resource shall submit Self-schedule associated with the corresponding CRN in the same manner as normal CRN:</p> <p>Treat each CRN as an independent CRN, existing CRN function in DAM and RTM are applicable:</p> <ul style="list-style-type: none"> • The contract can be exercised by SC submitting balanced self-schedules for associated resources that do not exceed the individual contract capacities, and in aggregate the entitlement. • If the high priority self-schedules are not balanced (in DAM) or they violate the entitlement, they are converted to regular (PT) self-schedules (the financial right still applies to the balanced portion in settlements) • In RTM, there are no load schedules, thus load meters are used instead • For transit CRNs, it is the responsibility of the SC(s) to exercise the contract within its applicable entitlement, reflect derate • Specifically, and only for TSRs, unused entitlement (above any submitted self-schedules) can be released to the market; <p>Note: See Appendix A7: Transmission Right sales example</p>	Existing	SIBR

 California ISO	Technology	Template Version:	6.8
		Document Version:	4.61.7
Extended Day Ahead Market Business Requirements Specification - Planning		Date Created:	1/21/2026

ID#	Business Feature	Requirement Type	Potential Application(s) Impacted
EDAM-BRQ-11280	SIBR will consider resource Pmin for Flexible RA capacity	Core	SIBR
EDAM-BRQ-11290	EDAM entity to activate hourly Net export transfer out constraint, CF, and RM by 09:00 am <ul style="list-style-type: none"> • EDAM entities activate the constraint for selected hours of the day, and submit <ul style="list-style-type: none"> ○ Confidence Factor (CF) (between 0 to 1)) ○ Hourly Reliability Margin (RM) 	Core	SIBR
EDAM-BRQ-11291	SIBR to broadcast/report on the EDAM entity submitted hourly net export transfer out constraint, CF, and RM <ul style="list-style-type: none"> • Hourly Net export transfer out constraint Status • Confidence Factor (CF) (between 0 to 1)) • Hourly Reliability Margin (RM) 	Core	SIBR
EDAM-BRQ-11295	Allow EDAM Entity to access to resources and inertia submitted bids for RSE in the BAA <ul style="list-style-type: none"> • Entity will have access to individual resource submitted bid-in quantity of bids, without pricing information, associated with the EDAM Resources within the Balancing Authority Area it represents and at EDAM Inerties with other Balancing Authority Areas • The entity is able to see the bid capacity data per hour, for example if the SC bids 0-320 using a 10-bid segment, the entity would see 320MW bid capacity from the resource • The bid is split by product type, energy and IRU/IRD, with sum of the total BAA by product • EDAM Entity shall be allowed to access display UI and download the bids 	Core	SIBR
EDAM-BRQ-11295a	Provide EDAM Entity Access to Resource and Inertia Submitted Capacities for Market Accepted Bids in each BAA <ul style="list-style-type: none"> • Market Type • Market Period start • Market Period stop • Host Control Area 	Core	SIBR

 California ISO	Technology	Template Version:	6.8
		Document Version:	6.1.7
Extended Day Ahead Market Business Requirements Specification - Planning		Date Created:	1/21/2026

ID#	Business Feature	Requirement Type	Potential Application(s) Impacted
	<ul style="list-style-type: none"> • Scheduling Coordinator • Resource MRID • HAS_BID_YN • Interval Start Time • Interval End Time • Product Type (Energy/Total Self-Schedule/RCU/RCD/IRU/IRD/RU/RD/SR/NR) • Energy - (highest) bid capacity • TSS – (sum of all PT/LPT/ETC/TOR/OATT1/OATT2 GSS/LSS) • IRU bid capacity • IRD bid capacity • RCU bid capacity • RCD bid capacity • RU Self-Provision capacity • RD Self-Provision capacity • SR Self-Provision capacity • NR Self-Provision capacity 		
EDAM-BRQ-11295b	<p>Allow EDAM entity to retrieve the resources and intertie submitted bids for RSE in the BAA</p> <ul style="list-style-type: none"> • EDAM entity can retrieve the resources and intertie latest submitted bids on-demand through B2B API <p>Notes:</p> <ul style="list-style-type: none"> • DAM data is only available after the MF refresh for the active day (1:30am for next day) • View data is updated every 5 min 	Core	SIBR AIM
EDAM-IST-BRQ-11400	<p>System shall identify the registered resource Registered Trading hub and registered load aggregated point as valid trading location</p> <p>For EDAM and WEIM footprint:</p> <ul style="list-style-type: none"> • Receive Master File defined 	Core	SIBR

 California ISO	Technology	Template Version:	6.8
		Document Version:	4.61.7
Extended Day Ahead Market Business Requirements Specification - Planning		Date Created:	1/21/2026

ID#	Business Feature	Requirement Type	Potential Application(s) Impacted
	<ul style="list-style-type: none"> ○ Registered Resources, ○ Registered Trading Hubs ○ Registered load aggregation points <p>List the above as valid trade locations</p> <p>Note: this BRQ is slated for 8/1/26 go-live</p>		
EDAM-IST-BRQ-11410	<p>Allow registered SC to submit the inter-SC trade</p> <p>The submit SC must be specified in the submitted trade</p> <ul style="list-style-type: none"> ○ The SC can be any registered SC, but not as NPM SC <p>Note: this BRQ is slated for 8/1/26 go-live</p>	Core	SIBR
EDAM-IST-BRQ-11420	<p>Allow SC to submit inter-SC trades at valid location</p> <p>Valid Inter SC trade locations include locations in CISO, EDAM/WEIM and WEIM BAA</p> <ul style="list-style-type: none"> ● List of resource locations for PHY ● Trading hubs (APN) ● Aggregation points (APN) <p>Note: this BRQ is slated for 8/1/26 go-live</p>	Existing	SIBR
EDAM-IST-BRQ-11430	<p>Continue support All type of inter-SC trading for CISO BAA</p> <p>If SC submitted trade with the trade location is in the CISO BAA, all trade types are valid:</p> <ul style="list-style-type: none"> ● Regulation Down ● Spinning Reserve ● UCT ● Regulation Up ● APN Energy ● CPT Energy ● Non-Spinning reserve ● PHY Energy <p>Note: this BRQ is slated for 8/1/26 go-live</p>	Existing	SIBR
EDAM-IST	<p>Only allow inter-SC trading for Energy (IST) for the EDAM and WEIM BAA outside of CISO</p>	Core	SIBR



ID#	Business Feature	Requirement Type	Potential Application(s) Impacted
BRQ-11440	<p>If SC submitted trade with the trade location is outside of CISO, in EDAM or WEIM BAA</p> <ul style="list-style-type: none"> ● Only energy trades are valid <ul style="list-style-type: none"> ○ APN Energy ○ CPT Energy ○ PHY Energy ● Any AST and UCT trades outside of CISO are invalid ● SC can cancel the IST before the relevant market close <p>Note: this BRQ is slated for 8/1/26 go-live</p>		
EDAM-IST-BRQ-11450	<p>For PHY energy trade in DAM, the trade location must be a registered generator resource</p> <ul style="list-style-type: none"> ● The resource must be a MF registered generator resource in EDAM BAAs ● All internal resources are participating EDAM market <p>Note: this BRQ is slated for 8/1/26 go-live</p>	Existing	SIBR
EDAM-IST-BRQ-11460	<p>For PHY energy trade in RTM, the trade location must be a registered generator resource that participates in WEIM</p> <ul style="list-style-type: none"> ● Only the participating resource can be the location of the IST trade. ● Trade validation: if no bid has been submitted, the trade is invalid. Since non-participating resources have no bid, the trade is invalid at non-participating resource <p>Note: this BRQ is slated for 8/1/26 go-live</p>	Core	SIBR
EDAM-IST-BRQ-11470	<p>The system resource and virtual resource shall not be trade locations</p> <p>All the system resource shall not be trade location:</p> <ul style="list-style-type: none"> ● System resources, intertie resource import/export ● Transfer resource (TSR, ETSR) ● Mirror resource ● Virtual resource ● Only populate Gen and NGR from MF for PHY trade 	Core	SIBR

 California ISO	Technology	Template Version:	6.8
		Document Version:	4.61.7
Extended Day Ahead Market Business Requirements Specification - Planning		Date Created:	1/21/2026

ID#	Business Feature	Requirement Type	Potential Application(s) Impacted
	<p style="color: red;">Note: this BRQ is slated for 8/1/26 go-live</p>		
EDAM-IST-BRQ-11480	<p>No change to the Inter-SC trade timeline</p> <ul style="list-style-type: none"> ● The configurable DAM Trade Post Close Time must be initialized to 1 hour after DAM Market Close Time The configurable RTM Trade Post Close Time must be at T-45 after RTM Market Close Time ● Trade Cyclic Validation occurs after Trade Pre-Market Close Time every 20 minutes till Trade Market Close Time. The last run has to occur immediately after Trade Close Time <p style="color: red;">Note: this BRQ is slated for 8/1/26 go-live</p>	Existing	SIBR
EDAM-IST-BRQ-11490	<p>Existing IST pre-market Validation rules shall apply to IST in EDAM and WEIM</p> <p>All existing SIBR rules for IST apply to EDAM WEIM IST Including:</p> <ul style="list-style-type: none"> ● IST PHY trade must not be greater than the registered Maximum Capacity for any Online Generating Resource ● Inter-SC Trade (IST) Matching paired trades with From and To SC, if no match, send warning message to both SCs. ● Inter-SC PHY Trade Cyclic Market Validation: If IST PHY trades exceed resource limit of higher of energy bid and Operating limit minus the validated trades, Pro-rata the IST trades accordingly. Validated Trade Quantity will be set to their reduced quantity <ul style="list-style-type: none"> ○ validated Trade Quantity will be set to Submitted Trade Quantity ○ notify all SCs involved in these PHYs about the reason for the adjustments ● Trades that pass Cyclic Market Validation must become Conditionally Valid Trades <p style="color: red;">Note: this BRQ is slated for 8/1/26 go-live</p>	Existing	SIBR

 California ISO	Technology	Template Version:	6.8
		Document Version:	4.61.7
Extended Day Ahead Market Business Requirements Specification - Planning		Date Created:	1/21/2026

ID#	Business Feature	Requirement Type	Potential Application(s) Impacted
EDAM-IST-BRQ-11500	<p>Existing IST Market Close Validation shall apply to IST in EDAM and WEIM</p> <p>All Matched Trades of Trade Category APN must become Valid IST Trades. Unmatched and Conditionally Invalid IST Trades must become Invalid IST Trades.</p> <ul style="list-style-type: none"> • All Trades of IST Trade Type, of Category PHY that are of status Conditionally Valid or Conditionally Modified and that pass the Trade Post Close Validation will be promoted to Valid or Modified Trades. 	Existing	SIBR
EDAM-IST-BRQ-11510	<p>Existing IST post-market Validation rules shall apply to IST in EDAM and WEIM</p> <p>For all IST Trades of Trade Category PHY:</p> <ul style="list-style-type: none"> • If the sum of all Submitted Trade Quantities of the PHYs which share the Trading Location is greater than the Day Ahead Energy Schedule of the Trade Location Generator for the Trade Period of the Trade, these PHYs will be reduced pro-rata according to their Submitted Trade Quantity • If the sum of all Submitted Trade Quantities of the Real Time PHYs which share the Trading Location is greater than the difference of the HASP Energy Schedule awarded to the Trade Location Generator for the Trade Period of the PHY, and the sum of the Validated Trade Quantities of the Valid and Modified Day Ahead PHYs whose Depend On Name points to the Generating Resource that is the specified Trading Location of the Real Time Trades, these Real Time PHYs will be reduced pro-rata according to their Submitted Trade Quantity <p>Note: this BRQ is slated for 8/1/26 go-live</p>	Existing	SIBR
EDAM-IST-BRQ-11520	<p>Generated CPT for the difference of PHY trade validated and DAM schedule</p> <ul style="list-style-type: none"> • Generate an IST Trade of Trade Category CPT with the Trade Quantity set to the difference between the Validated Trade Quantity and the Day Ahead Energy 	Existing	SIBR

 California ISO	Technology	Template Version:	6.8
		Document Version:	4.61.7
Extended Day Ahead Market Business Requirements Specification - Planning		Date Created:	1/21/2026

ID#	Business Feature	Requirement Type	Potential Application(s) Impacted
	Schedule of the Trade Location Generator for the Trade Period of the Trade, <ul style="list-style-type: none"> • CPT Trade Location set to the corresponding registered Trading Hub of the Trade Location Generator of EDAM BAA. • The system shall notify all SCs involved in these PHYs about the generation of CPTs. Note: this BRQ is slated for 8/1/26 go-live		
EDAM-IST-BRQ-11530	Generate CPT for the difference of PHY trade validated and HASP (FMM advisory) schedule <ul style="list-style-type: none"> • Generate an IST Trade of Trade Category CPT with the Trade Quantity set to the difference between the Validated Trade Quantity and the HASP Energy Schedule of the Trade Location Generator for the Trade Period of the Trade, • CPT Trade Location set to the corresponding registered Trading Hub of the Trade Location Generator of EDAM/WEIM BAA. • The system shall notify all SCs involved in these PHYs about the generation of CPTs. Note: this BRQ is slated for 8/1/26 go-live	Existing	SIBR
EDAM-TSR-BRQ-11139a	New SIBR role for EDAM BAA <ul style="list-style-type: none"> • Develop new role in SIBR for the EDAM BA (EESC) to submit the following data into SIBR: <ul style="list-style-type: none"> ○ BAA requirements ○ TC List and CRN Capacity ○ Total tagged import quantity 	Core	SIBR
EDAM-TSR-BRQ-11140	Step 1: EESC submits TCSC list and CRN Capacity to support TSR Types 1 and 2 <ul style="list-style-type: none"> • The EESC on each side of a transfer location may submit into SIBR a list of TCSCs and associated total transfer rights capacities before 9:00 am <ul style="list-style-type: none"> ○ TRANSFER LOCATION_ID (EESC must be the EDAM Entity for the FROM_BAA_ID) 	Core	SIBR

 California ISO	Technology	Template Version:	6.8
		Document Version:	4.61.7
Extended Day Ahead Market Business Requirements Specification - Planning		Date Created:	1/21/2026

ID#	Business Feature	Requirement Type	Potential Application(s) Impacted
	<ul style="list-style-type: none"> ○ TH (Trading Hour): The list of TCSCs and associated CRN Capacity is hourly data ○ SC_ID (this is the TCSC) <ul style="list-style-type: none"> ▪ Registered SC ID; it must not be an EESC ○ CRN_ID: must be registered in MF, to support multiple contracts per TCSC ○ CRN_Capacity (MW): quantity of MW rights TCSC has at specific location (out of total entitlement). Greater than or equal to the sum of all Maximum Capacities defined for TSR Type 1s at a specific location. <ul style="list-style-type: none"> ● Submissions may be received up to 6 days before the current trading day while the market is open <p>Note: If no submission is received by EESC, the maximum capacity registered in MF is used for subsequent TCSC validation</p>		
EDAM- TSR- BRQ- 11141a	<p>Step 2a: Support TCSC submission of TSR attributes for transient DA TSR Type 1 with CRN rights</p> <p>Allow TCSC to submit the following information for the next Trading Day for each Trading Hour before 9:00 am:</p> <ul style="list-style-type: none"> ● TRANSFER_LOCATION_ID ● RES_ID (TSR ID): SC_ID-FROM BAA ID TO BAA ID INTERTIE ID DIRECTION-TSR_TYPE-MATCHING_SC_ID-<i>nn</i> <ul style="list-style-type: none"> ○ Where '<i>nn</i>' is an alphanumeric identifier to distinguish otherwise similar TSRs. ● CRN_ID: "NONE" may be specified for one contract on one side ● SELF-SCHEDULE (MW) for each TH; cannot exceed the Maximum Capacity <ul style="list-style-type: none"> ○ Self-schedule may be updated until 10:00 am, however the TSR definition is locked at 9:00 am ○ Receive the scheduling priority associated with the CRN_TYPE of 	Core	SIBR

 California ISO	Technology	Template Version:	6.8
		Document Version:	4.61.7
Extended Day Ahead Market Business Requirements Specification - Planning		Date Created:	1/21/2026

ID#	Business Feature	Requirement Type	Potential Application(s) Impacted
	<p style="text-align: right;">the CRN ID (DAPT for CRN_ID "NONE")</p> <p>TSR attributes:</p> <ul style="list-style-type: none"> • MAXIMUM_CAPACITY (MW) • MARKET_START: start of a TD • MARKET_STOP: end of the same TD as the start • INTERVAL_START: Trading hour start • INTERVAL_END: Trading hour stop • SC_ID • TSR_TYPE (1) • RSE flag (Y) • MATCHING_SC_ID; "CISO" may be specified for half-contract matching with CISO • MATCHING_RES_ID • MATCHING_TRANSFER_LOCATION_ID <p>Note: A TCSC must register different TSR pairs for different matching SCs and/or different CRNs</p>		
EDAM-TSR-BRQ-11141b	<p>Step 2b: Allow TCSC to Submit Released Capacity Bids at Transfer Location before 9 am</p> <ul style="list-style-type: none"> • Only the TCSC's defined by the EESC (per Step 1: EDAM-TSR-BRQ-11141a) or in the list of MF CRN Capacity by transfer capacity/SC (EDAM-TSR-BRQ-02315) can submit a Released Capacity bid • Released Capacity bids are submitted for each CRN ID at a specific transfer location, by hour, and by TCSC • Released Capacity shall not exceed the CRN Capacity defined at the transfer location by the EESC per the CRN • Bids shall include: <ul style="list-style-type: none"> ○ TRANSFER_LOCATION_ID ○ CRN_ID: must be a registered CRN ○ RELEASED_CAPACITY (MW) for each TH; pathway 2 capacity – use this to create TSR ID for Type 2s ○ SC_ID ○ MARKET_START: start of a TD ○ MARKET_STOP: end of the same TD as the start ○ INTERVAL_START: Trading hour start ○ INTERVAL_END: Trading hour stop 	Core	SIBR

 California ISO	Technology	Template Version:	6.8
		Document Version:	4.6 1.7
Extended Day Ahead Market Business Requirements Specification - Planning		Date Created:	1/21/2026

ID#	Business Feature	Requirement Type	Potential Application(s) Impacted
	Note: If no submission has been received by EESC, the maximum capacity registered in MF is used for subsequent TCSC validation		
EDAM-TSR-BRQ-11141c	Validation for Step 2 - Before the advisory RSE runs: Validate TCSC is included in the list submitted by the EESC for the CRN and Transfer Location <ul style="list-style-type: none"> If the TCSC is not in the list (default in MF, or as updated by the EESC in Step 1), reject the submission 	Core	SIBR
EDAM-TSR-BRQ-11141e	Validation for Step 2: Paired TSR Definition Cross Validation for Registered and Transient TSR Submissions System shall cross validate TSR definition with matching TSR definition (MATCHING RES_ID) on each side of transfer location. Specifically, the following attributes shall be validated for matching TSRs: <ul style="list-style-type: none"> RES_ID must be the same as MATCHING_RES_ID in the matching TSR definition. TRANSFER_LOCATION_ID must properly match the MATCHING_TRANSFER_LOCATION_ID SELF-SCHEDULE should be the same in the matching TSR definition, otherwise the lower value prevails. Notes: <ul style="list-style-type: none"> If the paired TSR fails cross validation then the TSR pair shall not be valid for the DAM The validated TSR pair will be the effective resource IDs for the corresponding trading day only 	Core	SIBR
EDAM-TSR-BRQ-11141f	Validation for Step 2: Validate that CRN Self-Schedule and Released Capacity do not exceed CRN Capacity <ul style="list-style-type: none"> For information received from MF or updated by the EESC (Step 1) and TCSC (Step 2) for TSR Type 1 bids and Released Capacity bids, validate before each broadcast cut-off time for each RSE run: <ul style="list-style-type: none"> For each CRN and each interval, Sum of SELF-SCHEDULES from registered and transient Type 1 bids and RELEASED_CAPACITY from SC (Step 2) 	Core	SIBR

 California ISO	Technology	Template Version:	6.8
		Document Version:	6.1.7
Extended Day Ahead Market Business Requirements Specification - Planning		Date Created:	1/21/2026

ID#	Business Feature	Requirement Type	Potential Application(s) Impacted
	<ul style="list-style-type: none"> ○ must not exceed CRN CAPACITY from the MF or EESC submission (Step 1); ○ If CRN Capacity is exceeded, all TSR submissions at that Transfer Location, CRN, and TCSC and their Matching TSRs shall be) invalid ● Revalidate any updates received by EESCs until 9:00 am, or TCSCs until 10:00 am 		
EDAM-TSR-BRQ-11142a	<p>Step 3a: for one side of CRN transfer with CAISO BAA: Auto generate matching Type 1 TSR ID for ISO or actual CRN on only one side of transfer</p> <ul style="list-style-type: none"> ● If MATCHING_SC_ID is CISO, SIBR shall insert matching self-schedule for the CISO side of transfer ● SIBR generates the MATCHING_RES_ID for a “CISO” MATCHING_SC_ID ● Include a matching DAPT self-schedule ● Include the generic “NONE” CRN_ID. 	Core	SIBR
EDAM-TSR-BRQ-11142b	<p>Step 3b: For TSR Type 1 transfers between EDAM BAAs (not including the CAISO BAA), SC must submit TSR pairs</p> <p>The MATCHING_SC_ID must submit TSR Type 1 self-schedule to match the self-schedule of its mirror</p>	Participant Core	SIBR
EDAM-TSR-BRQ-11144b	<p>Step 4: Dynamic Matching for Transient Type 2 TSRs at 9 am</p> <p>System shall match TSR pairs per Transfer Location pair, matching imports on one side with exports on the other side for the market period:</p> <ul style="list-style-type: none"> ● First, aggregate the Released Capacity by TCSC across all relevant CRNs ● Second, subtract from the Released Capacity the sum of Capacity Limits in in registered TSR Type 2 bids from that TCSC, CRN, and Transfer Location ● Third, list TC Total Released Capacity by TCSC in ascending order for each Transfer Location in the pair 	Core	SIBR

 California ISO	Technology	Template Version:	6.8
		Document Version:	6.1.7 1.7
Extended Day Ahead Market Business Requirements Specification - Planning		Date Created:	1/21/2026

ID#	Business Feature	Requirement Type	Potential Application(s) Impacted
	<ul style="list-style-type: none"> • Fourth, if the TO_BAA_ID of the TRANSFER_LOCATION_ID is not "CISO", the long side with larger Total Released Capacity is reduced pro rata on the Total Released Capacity to match the grand total on the short side. Otherwise, the Released Capacity on the CISO side of the TRANSFER_LOCATION_ID will fill in up to the Total Released Capacity on the other side. • Fifth, the Total Released Capacities from both sides are sliced horizontally at all TCSC boundaries, including CISO generic capacity, if applicable, to yield matching offers • Sixth, define TSR Type 2 pairs for the matching offers: Matching capacity offers then become the Maximum Capacity of TSR Type 2 pairs that are defined by SIBR using the naming convention: SC ID-FROM_BAA_ID_TO_BAA_ID_INTERTIE_ID_DIRECTION-TSR_TYPE-MATCHING SC ID-nn, where the alphanumeric identifier 'nn' is the market period (1-25) for the relevant Trading Hour • Create TSR Type 2 Attributes: <ul style="list-style-type: none"> ○ TRANSFER_LOCATION_ID ○ RES_ID (TSR ID): SC ID-FROM_BAA_ID_TO_BAA_ID_INTERTIE_ID_DIRECTION-TSR_TYPE-MATCHING_SC_ID-nn ○ MARKET_START: start of a TD ○ MARKET_STOP: end of the same TD as the start ○ INTERVAL_START: Trading hour start ○ INTERVAL_END: Trading hour stop ○ SC_ID ○ TSR_TYPE (2) ○ RSE_YN=N ○ MAXIMUM_CAPACITY: the size (MW) of the matched offer ○ MATCHING_SC_ID; the SC of the mirror TSR, which will be "CISO" if the TO_BAA in TRANSFER_LOCATION_ID is "CISO" ○ MATCHING_RES_ID of the SIBR generated matched offer RES_ID • SIBR will set the CAPACITY_LIMIT equal to the MAXIMUM_CAPACITY 		

 California ISO	Technology	Template Version:	6.8
		Document Version:	6.1.7
Extended Day Ahead Market Business Requirements Specification - Planning		Date Created:	1/21/2026

ID#	Business Feature	Requirement Type	Potential Application(s) Impacted
	Note: The transfer capacity under the Capacity Limit is released to EDAM for optimal scheduling in the IFM and RUC.		
EDAM- TSR- BRQ- 11144d	<p>Step 5: Notify EESC and TCSC of Dynamically Matched Type 2 TSRs</p> <p>SIBR shall notify the corresponding TCSCs and their EESCs about their defined Type 2 TSRs; no TSR bid will be accepted for these TSRs. Include all TSR attributes, including:</p> <ul style="list-style-type: none"> • RES_ID: Resource ID • SC_ID: Scheduling Coordinator • MAXIMUM_CAPACITY: Maximum Capacity • TSR_TYPE: 2 • RSE_YN: N • MATCHING_TSR_ID: Matching TSR Resource ID • TRANSFER_LOCATION: Transfer Location 	Core	SIBR
EDAM- TSR- BRQ- 11144e	<p>Support TCSC submission of TSR attributes for Registered Type 1</p> <p>Allow TCSC to submit TSR Type 1 self-schedules for registered TSR Type 1 before 9:00 am:</p> <ul style="list-style-type: none"> • RES_ID (TSR ID): SC ID FROM BAA ID TO BAA ID INTERTIE ID DIRECTION_TSR_TYPE_MATCHING_SC_ID_nn <ul style="list-style-type: none"> ○ Where 'nn' is an alphanumeric identifier to distinguish otherwise similar TSRs. • SELF-SCHEDULE (MW) for each TH; cannot exceed the Maximum Capacity <ul style="list-style-type: none"> ○ Self-schedule receives scheduling priority associated with CRN_TYPE of the CRN_ID (DAPT priority for CRN_ID "NONE") <p>TSR attributes:</p> <ul style="list-style-type: none"> • MARKET_START: start of a TD • MARKET_STOP: end of the same TD as the start • INTERVAL_START: Trading hour start • INTERVAL_END: Trading hour stop <p>SC_ID</p>	Core	SIBR

 California ISO	Technology	Template Version:	6.8
		Document Version:	4.61.7
Extended Day Ahead Market Business Requirements Specification - Planning		Date Created:	1/21/2026

ID#	Business Feature	Requirement Type	Potential Application(s) Impacted
EDAM-TSR-BRQ-11144f	<p>Support TCSC submission of TSR attributes for Registered Type 2</p> <p>Allow TCSC to submit TSR Type 2 self-schedules for registered TSR Type 2 before 9:00 am:</p> <ul style="list-style-type: none"> • RES_ID (TSR ID): SC_ID FROM BAA_ID TO BAA_ID INTERTIE_ID DIRECTION_TSR_TYPE_MATCHING_SC_ID_nn <ul style="list-style-type: none"> ○ Where 'nn' is an alphanumeric identifier to distinguish otherwise similar TSRs. • Capacity Limit: Cannot exceed the registered Maximum Capacity value in the MF <p>TSR attributes:</p> <ul style="list-style-type: none"> • MARKET_START: start of a TD • MARKET_STOP: end of the same TD as the start • INTERVAL_START: Trading hour start INTERVAL_END: Trading hour stop • SC_ID 	Core	SIBR
EDAM-TSR-BRQ-11144h	<p>TSR Type 2 Cross Validation</p> <ul style="list-style-type: none"> • For each CRN, the sum of Capacity Limits from registered Type 2 bids must not exceed the RELEASED_CAPACITY for the TCSC, CRN, and Transfer Location • If RELEASED_CAPACITY is exceeded, all TSRs submissions at that Transfer Location, CRN, and TCSC become invalid, and their Matching TSRs become pending 	Core	SIBR
EDAM-TSR-BRQ-11145a	<p>Support EESC submission of TSR attributes for Registered Type 3</p> <p>Allow EESC to submit TSR Bids for TSR Type 3 that are registered in the MF for the next Trading Day for each Trading Hour before 10:00 am:</p> <ul style="list-style-type: none"> • RES_ID (TSR ID): SC_ID FROM BAA_ID TO BAA_ID INTERTIE_ID DIRECTION_TSR_TYPE_nn where 'nn' is an alphanumeric identifier to distinguish otherwise similar TSRs. • Capacity Limit: Cannot exceed the registered Maximum Capacity value in the MF • AS Self Provision: <ul style="list-style-type: none"> ○ RU 	Core	SIBR

 California ISO	Technology	Template Version:	6.8
		Document Version:	6.1.7 1.7
Extended Day Ahead Market Business Requirements Specification - Planning		Date Created:	1/21/2026

ID#	Business Feature	Requirement Type	Potential Application(s) Impacted
	<ul style="list-style-type: none"> ○ RD ○ SR ○ NR ● The sum of the AS self-provision cannot exceed the Capacity Limit 		
EDAM-TSR-BRQ-11145b	<p>Type 3 TSR Bid Validation</p> <ul style="list-style-type: none"> ● Accept Type 3 TSR bids for MF-registered Type 3 TSRs, specify a Capacity Limit that may not exceed the TSR Maximum Capacity. ● Type 3 TSRs can specify ancillary services self-provision for regulation up (RU), regulation down (RD), spinning reserve (SR), or non-spinning reserve (NR), with a total that is not greater than the Capacity Limit. <ul style="list-style-type: none"> ○ SIBR will enable AS self-provision for TSR Type 3 (no certification in MF). ● Reduce the Capacity Limit to match a lower Capacity Limit submitted for the matching TSR. ● If the Capacity Limit is reduced, as submitted by the EESC, SIBR will reduce any ancillary services self-provision as follows: <ul style="list-style-type: none"> ○ $RU \leftarrow \min(\text{Capacity_Limit}, RU + RD) \times RU / (RU + RD)$ ○ $RD \leftarrow \min(\text{Capacity_Limit}, RU + RD) \times RD / (RU + RD)$ ○ $SR \leftarrow \min(\text{Capacity_Limit} - RU - RD, SR)$ NR $\leftarrow \min(\text{Capacity_Limit} - RU - RD - SR, NR)$ ● Any remaining transfer capacity between the Capacity Limit and the total ancillary services self-provision is released to EDAM for optimal scheduling in the IFM and RUC. 	Core	SIBR
EDAM-TSR-BRQ-11145c	<p>Type 3 TSR Pairs with the CISO BAA</p> <ul style="list-style-type: none"> ● System shall generate a bid for the CISO TSR as the MATCHING_RES_ID when the MATCHING_SC_ID=CISO with the same Capacity Limit and AS self-provision as that of the Matching TSR. 	Core	SIBR

 California ISO	Technology	Template Version:	6.8
		Document Version:	6.1.7 1.7
Extended Day Ahead Market Business Requirements Specification - Planning		Date Created:	1/21/2026

ID#	Business Feature	Requirement Type	Potential Application(s) Impacted
EDAM- TSR- BRQ- 11146a	Support EESC submission of TSR attributes for Registered Type 4 TSRs <ul style="list-style-type: none"> • Allow EESC to submit TSR Bids for Type 4 TSRs for the next Trading Day for each Trading Hour before 10:00 am: • RES_ID (TSR ID): SC ID FROM BAA ID TO BAA ID INTERTIE ID DIRECTION_TSR_TYPE_nn where 'nn' is an alphanumeric identifier to distinguish otherwise similar TSRs. 	Core	SIBR
EDAM- TSR- BRQ- 11146b	Type 4 TSR Bid Validation <ul style="list-style-type: none"> • Accept Type 4 TSR bids for MF-registered Type 4 TSRs, specify a Capacity Limit that must not be greater than the MF registered TSR Maximum Capacity. • Reduce the Capacity Limit to match a lower Capacity Limit submitted for the matching TSR. • The transfer capacity equal to the Capacity Limit is released to EDAM for optimal scheduling in the IFM and RUC. <p>Note: No A/S self-provision will be present for Type 4 TSRs</p>	Core	SIBR
EDAM- TSR- BRQ- 11146c	Type 4 TSR Pairs with the CISO BAA <p>System shall generate a bid for the MATCHING_RES_ID when the MATCHING_SC_ID=CISO with the same Capacity Limit</p>	Core	SIBR
EDAM- TSR- BRQ- 11161	Notification for TSR Bids in DAM <ul style="list-style-type: none"> • After 9:00 am for Type 1 TSRs only: the system shall calculate and notify the EESC about the sum of the Type 1 TSR self-schedules, Released Capacity, and CRN Capacity for a TCSC, CRN, and Transfer Location. • The system shall also calculate and notify the EESC about the reserved right which is the difference between the CRN Capacity and (the sum of TSR Type 1 self-schedules and the Released Capacity). <p>Notes:</p>	Core	SIBR

 California ISO	Technology	Template Version:	6.8
		Document Version:	6.1.7 1.7
Extended Day Ahead Market Business Requirements Specification - Planning		Date Created:	1/21/2026

ID#	Business Feature	Requirement Type	Potential Application(s) Impacted
	If the CRN allows the exercise of rights in RTM, the TCSC can exercise reserved rights via a TSR re-bid in RTM by increasing the CRN self-schedule		
EDAM-TSR-BRQ-11155	Consume and process TSR Maximum Capacity Updates for all TSR Types by T-75 <ul style="list-style-type: none"> • For TSR's that are updated in RT due to a derate, capacity reduction, or capacity increase (e.g., resolved outage) the system shall update TSR Maximum Capacity: <ul style="list-style-type: none"> ○ For registered TSRS: Maximum Capacity increases shall not exceed the registered Maximum Capacity ○ For Type 1 TSRs defined by TCSCs: Maximum Capacity updates in RTM shall not exceed the Maximum Capacity specified in the DAM ○ For Type 2 TSRs: Capacity increases shall not exceed the SIBR generated capacity 	Core	SIBR
EDAM-TSR-BRQ-11156	Calculate Updated Schedule for Re-Defined TSRs in RT for EN, AS, IR, and RCU as follows: <u>Energy schedule (EN):</u> <ul style="list-style-type: none"> • $EN \leftarrow \min(UOL, EN)$ <u>Ancillary services awards:</u> <ul style="list-style-type: none"> • $RU \leftarrow \min(UOL - EN, RU)$ • $RD \leftarrow \min(EN, RD)$ • $SR \leftarrow \min(UOL - EN - RU, SR)$ • $NR \leftarrow \min(UOL - EN - RU - SR, NR)$ <u>Imbalance Reserve Awards:</u> <ul style="list-style-type: none"> • $IRU \leftarrow \min(UOL - EN - RU - SR - NR, IRU)$ • $IRD \leftarrow \min(EN - RD, IRD)$ <u>Reliability Capacity Up Awards:</u> <ul style="list-style-type: none"> • $RCU \leftarrow \min(UOL - EN - RU - SR - NR - IRU, RCU)$ 	Core	SIBR

 California ISO	Technology	Template Version:	6.8
		Document Version:	6.1.7
Extended Day Ahead Market Business Requirements Specification - Planning		Date Created:	1/21/2026

ID#	Business Feature	Requirement Type	Potential Application(s) Impacted
EDAM-TSR-BRQ-11170	Consume Entity Submitted Entitlement Updates <ul style="list-style-type: none"> • Entitlements submitted between 9 am - 10 am for the next TD are invalidated and notify participant that update must be submitted after 10 am • Any Entitlement update received after 10 am will be considered a RT Entitlement adjustment 	Core	SIBR
EDAM-TSR-BRQ-11165	CRN Balancing Validation by CRN by BAA <ul style="list-style-type: none"> • SIBR shall validate for each CRN, except "NONE" that self-schedules associated with that CRN from resources in each BAA are balanced: <ul style="list-style-type: none"> ○ Balanced shall be defined as: the sum of the supply from generating resources, imports, import TSRs etc. is equal to the sum of demand from load, export TSRs, and exports. ○ If the validation fails for any BAA, the entire CRN balancing validation fails, hence the priority indicator for that CRN shall be set to N <p>Notes:</p> <ul style="list-style-type: none"> • Include NGRs in the CRN balancing rules • Only applies to DA timeframe 	Core	SIBR
EDAM-TSR-BRQ-11166	CRN Entitlement Validation by CRN by BAA <ul style="list-style-type: none"> • SIBR shall validate for each CRN, except "NONE," that the sum of the supply self-schedules, i.e. generating resources, imports, import TSRs etc. associated with that CRN from resources in each BAA does not exceed the CRN Entitlement. • If the validation fails for any BAA, the entire CRN Entitlement validation fails, hence the priority indicator for that CRN shall be set to N, and notify participant <p>Notes:</p> <ul style="list-style-type: none"> • Treat NGRs as algebraic supply • Applies to both DA and RT timeframes 	Core	SIBR

 California ISO	Technology	Template Version:	6.8
		Document Version:	6.1.7 1.7
Extended Day Ahead Market Business Requirements Specification - Planning		Date Created:	1/21/2026

ID#	Business Feature	Requirement Type	Potential Application(s) Impacted
EDAM-TSR-BRQ-11175	TSR Type 1 Re-Bidding in RT <ul style="list-style-type: none"> For Type 1 TSRs in RT: the TCSC must re-bid in RT and the energy self-schedule is associated with the CRN Only existing Type 1 TSRs can be re-bid. TSRs cannot be re-defined in RT. 	Core	SIBR
EDAM-TSR-BRQ-11176	TSR Rollover for TSR Type 2, 3 and 4 in RT <ul style="list-style-type: none"> For TSR Types 2, 3 and 4 in RT: the energy schedule will be associated with a DA PT SS <ul style="list-style-type: none"> Any capacity awards (IRU/IRD/RCU/AS) will be copied over TSRs Types 2, 3, and 4 are not biddable in RT 	Core	SIBR
EDAM-TSR-BRQ-11180	Validation for TSR Bids in RTM <ul style="list-style-type: none"> The system shall not allow a schedules to exceed the Maximum Capacity of the TSR (applies to all TSR Types) At T-75 for Type 1 TSRs only: If the sum of the Type 1 TSR self-schedules, plus Released Capacity, for a TCSC, CRN, and Transfer Location, exceeds the CRN Capacity for that TCSC, CRN, and Transfer Location, the system shall invalidate the bid submission. After RT market close, if there is no RTM accepted bid for this TSR Type 1, the system shall insert the DA schedule for that TSR, and associate the self-schedule with the CRN based on the TSR definition and attributes. <p>Notes:</p> <p style="padding-left: 40px;">TSR Maximum Capacity may be updated in SIBR by EESC before T-75</p> <ul style="list-style-type: none"> Provide TCSC a warning that the submission is invalid. 	Core	SIBR
EDAM-BRQ-11190	Enforce Restricted GAP-TIE: Only allow SCs mapped to a Restricted GAP-TIE to submit transactions at the GAP-TIE Combination <ul style="list-style-type: none"> Consume flag and mapping defining SCs associated with restricted GAP-TIEs Enforce bidding rules such that only the SCs mapped to the restricted GAP-TIE can submit transactions at that GAP-TIE combination 	Core	SIBR

 California ISO	Technology	Template Version:	6.8
		Document Version:	4.6 1.7
Extended Day Ahead Market Business Requirements Specification - Planning		Date Created:	1/21/2026

ID#	Business Feature	Requirement Type	Potential Application(s) Impacted
	Note: See EDAM-BRQ-02345 for MF BRQ defining the flag In RT: Enforce Scheduling Rules for EDAM vs. WEIM GAP-TIE Combinations <ul style="list-style-type: none"> If GAP-TIE is between EDAM BAAs (includes all CISO ties): No bids are allowed at EDAM GAP-TIES For WEIM GAP-TIE: Bids are allowed only at non-WEIM GAP-TIES	Core	SIBR
EDAM-BRQ-11191	Consume EDAM BAA Contract Limits <ul style="list-style-type: none"> Receive the EDAM BAA registered contract limits: <ul style="list-style-type: none"> TOR ETC OATT 1 OATT 2 Note: Model two type of OATTs – hedge / non-hedge <ul style="list-style-type: none"> Hedging congestion for CRNs in the market and receiving a corresponding settlement No hedging: If OATT priority is higher than RT SS is communicated, it shall be given ELC equivalent priority 	Core	SIBR
EDAM-BRQ-13220	Extending DAM lock commitment cost function to EDAM: <ul style="list-style-type: none"> Binding DAM resource commitments should lock in the commitment cost bids (minimum load cost, startup cost, transition cost) in the RTM for the hours in which the resource was committed. 	Existing	SIBR
EDAM-BRQ-13225	Support Zero Import/Export Self-Schedules between EDAM and WEIM BAAs in RT <ul style="list-style-type: none"> The system shall support zero import/export self-schedules from Intertie Transactions in RTM at an EDAM intertie from/to an EIM BAA to/from an EDAM BAA, excluding the CISO BAA. The support shall be limited to only self-schedules, and only for zero MW, for the sole purpose of facilitating bilateral contracts after DAM between EDAM and EIM BAAs, because EDAM BAAs cannot have base transfers after EDAM deployment. 	Core	SIBR

 California ISO	Technology	Template Version:	6.8
		Document Version:	6.1.7
Extended Day Ahead Market Business Requirements Specification - Planning		Date Created:	1/21/2026

ID#	Business Feature	Requirement Type	Potential Application(s) Impacted
<u>EDAM-BRQ-13230</u>	<p style="color: red; margin: 0;"><u>Develop New Role to Allow EDAM Entity to Designate the SC to Submit AS Requirements</u></p> <ul style="list-style-type: none"> <li style="color: red; margin-bottom: 5px;">• <u>Create a new role specific to BAA AS requirements (self-provision) submission</u> <li style="color: red; margin-bottom: 5px;">• <u>The EDAM Entity shall be able to designate the SC to be provisioned this role to submit the AS requirements</u> <li style="color: red; margin-bottom: 5px;">• <u>If no SC is specified, this role shall not be assigned to any SC (EESC will continue to be the responsible party for submitting AS requirements)</u> 	<u>Process</u>	<u>AIM</u> <u>SIBR</u>

 California ISO	Technology	Template Version:	6.8
		Document Version:	6.1.7 1.7
Extended Day Ahead Market Business Requirements Specification - Planning		Date Created:	1/21/2026

5.7 Business Process: Manage DAM Resource Sufficiency Evaluation (DA-RSE)

- Consume BARC hourly Histogram and second-order polynomial coefficients for IRU/IRD
- Calculate/broadcast every 30 min, between 6 and 9 am, the hourly IRU/IRD requirements based on the latest forecasts
- Adjust each EDAM BAA's IRU/IRD Requirements according to the operator specified diversity benefit (DB)
- Adjust and broadcast each EDAM BAA's hourly requirements by RSE eligible transfer limits from sink to source BAA
- Every 30 minutes (timeframe is configurable), run DA-RSE optimization using the latest bids and without transmission constraints. Use penalty cost for IRU/IRD in RSE
- Manage DA-RSE Inputs: use 9 am forecasts and requirements, use 10 am bids for 10 am binding DA-RSE
- Identify the hourly results of success or fail and deficiency of the DA-RSE for each EDAM BAA
- Broadcast DA-RSE hourly results for each EDAM BAA and resource

5.7.1 Business Requirements

ID#	Business Feature	Requirement Type	Potential Application(s) Impacted
EDAM-BRQ-12008	Access Master file definition and association for EDAM: <ul style="list-style-type: none"> • Resource RSE flag for DA-RSE • DA TSR, RSE associated flags, contract number (CRN), and limits • GHG regulation area for DAM and RTM and resource association, GHG clap split on state boundary, GHG bids option flag of EDAM BAA, GHG pseudo-tie flag, and resources that are dynamically scheduled into a BAA that overlaps with a GHG regulation area • DR inclusion flag • BAA AET options 	Core	DAM DA-RSE (from MF)
EDAM-BRQ-12011	Consume TD hourly Histogram and the second-order polynomial coefficients for each EDAM BAA and EDAM footprint <ul style="list-style-type: none"> • Data Includes: <ul style="list-style-type: none"> • the High/low Percentile hourly forecast uncertainty histogram for net demand/demand/solar/wind 	Core DAME	DAM DA-RSE

 California ISO	Technology	Template Version:	6.8
		Document Version:	6.1.7
Extended Day Ahead Market Business Requirements Specification - Planning		Date Created:	1/21/2026

ID#	Business Feature	Requirement Type	Potential Application(s) Impacted
	<ul style="list-style-type: none"> The second-order polynomial coefficients of the High/low Percentile quadratic quantile regression of hourly forecast uncertainty for demand/solar/wind/Mosaic (net load) The hourly High/low Percentile Threshold forecast uncertainty histogram for net demand Threshold value of IRU and IRD requirements 		
EDAM-BRQ-12016	<p>Use same load forecast for DA-RSE and DAM</p> <p>Market will receive the Load forecast from ALFS, the load forecast will include DR adjustment if applicable. The Load forecast will be the same in DA-RSE and RUC</p>	Existing	DAM DA-RSE
EDAM-BRQ-12016 D	<p>Calculate hourly IRU/IRD requirements for each EDAM BAA and EDAM footprint</p> <ul style="list-style-type: none"> Calculate the hourly IRU/IRD requirements (IRUR/IRDR) between 6 am and 9 am, approximately every 30 minutes, using parameters and latest forecasts Bound the hourly IRUR/IRDR by the thresholds consumed from BARC Broadcast DAM the original IRU requirement (IRUR₆₀) and IRD requirement (IRDR₆₀) for each Trading Hour of the next Trading Day, for each EDAM BAA and EDAM Area <p>Notes</p> <ul style="list-style-type: none"> DA-RSE will use the adjusted IRU/IRD Requirements with Diversity Benefit. The market will publish the original requirement. 	Core	DAM DA-RSE
EDAM-BRQ-12017	<p>The DA-RSE will automatically run approximately every 30 minutes between 6AM and 9:30AM with the latest consumed dataset.</p>	Core	DAM DA-RSE

 California ISO	Technology	Template Version:	6.8
		Document Version:	6.1.7
Extended Day Ahead Market Business Requirements Specification - Planning		Date Created:	1/21/2026

ID#	Business Feature	Requirement Type	Potential Application(s) Impacted
EDAM-BRQ-12020	After configurable 9:30 (approximate) RSE run the DA-RSE can be manually run using the latest consumed dataset.	Core	DAM DA-RSE
EDAM-BRQ-12023	Extend to EDAM Calculate hourly IRU/IRD requirements for EDAM BAA for every RSE run <ul style="list-style-type: none"> • Calculate the hourly IRU/IRD requirements (IRUR/IRD) with every DA RSE run <ul style="list-style-type: none"> ○ Calculate IRUR/IRD for gen-only BAA using same method that incorporate the Variable resource uncertainty only • Bound the hourly IRUR/IRD by the thresholds consumed from BARC 	Core DAME	DAM DA-RSE
EDAM-BRQ-12025	Adjust each EDAM BAA's IRU/IRD Requirements according to diversity benefit (DB) operator specified portion <ul style="list-style-type: none"> • Calculate Diversity Benefit as difference between sum of individual BAA IRU/IRD requirement and requirement of entire EDAM footprint • Specify configurable parameters to specify portion of diversity benefit of IRU/IRD requirement, apply the IRU/IRD requirements in RSE and IFM for EDAM BAAs • Include diversity benefit that pro-rata allocated according to original requirement, for each EDAM BAA. • Display forecasted/adjusted IRUR, IRDR, DB 	Core	DAM DA-RSE
EDAM-BRQ-12040	Include RSE eligible TSR AS self-provision and TSR limits from sink to source BAA in DA-RSE optimization <ul style="list-style-type: none"> • Receive MF defined the maximum capacity (Pmax) for the TSRs and the RSE eligibility flag • Receive EDAM entity submitted bid Capacity Limit (CL), which is the released transfer capacity to the market • Receive EDAM entity submitted self-provide RU/RD/SR/NR ($T_{j,t}^{(RU)}$ $T_{j,t}^{(RD)}$ $T_{j,t}^{(SR)}$ $T_{j,t}^{(NR)}$) on TSR, just like any other resource. 	Core	DAM DA-RSE

 California ISO	Technology	Template Version:	6.8
		Document Version:	4.6 1.7
Extended Day Ahead Market Business Requirements Specification - Planning		Date Created:	1/21/2026

ID#	Business Feature	Requirement Type	Potential Application(s) Impacted
	<ul style="list-style-type: none"> • TSR remaining capacity $T_{j,t}^{(RSE)}$ under CL after AS self-provision will be used by RSE for optimized meeting of the requirement for energy and imbalance reserve • The TSR AS self-provision are placed in the right side of constraint to reduce the AS requirement from sink BAA and increase the requirement to the source BAA <ul style="list-style-type: none"> ○ Self-provision TSR regulation down (RD) shall have energy to support, therefore, the RD TSR will be added in the right side of energy and IR constraints. • RSE remaining capacity is placed in the right side of constraint to reduce the sum of energy and imbalance reserve requirement from sink BAA and increase the requirement to the source BAA, plus the RD TSR. • Use one upward / one downward relax variable for the BAA Energy and imbalance reserve <p>Note: Any remaining capacity under the CL will be used by the RSE, and later by the IFM, for energy/IR (co-optimize). Any remaining capacity can then be used in RUC for RCU. A TSR can have all commodities.</p>		
EDAM-BRQ-12050	<p>Activate load modification by Demand Response in RSE</p> <ul style="list-style-type: none"> • For PDR, DDR, use resource RSE eligible flag to determine if it counted in RSE, same as other supply resource • For demand response are NOT modeled as DAM supply resource (PDR,DDR) in the market, allow EDAM entity to submit the load adjustment (through ALFS, same as in WEIM, subject to attestation) 	Core	DAM DA-RSE
EDAM-BRQ-12060	<p>Support multiple forecast zones in a EDAM BAA same as WEIM</p> <ul style="list-style-type: none"> • Support multiple forecast zones in a EDAM BAA same as WEIM • DA-RSE is on EDAM BAA level 	Core	DAM DA-RSE

 California ISO	Technology	Template Version:	6.8
		Document Version:	4.6 1.7
Extended Day Ahead Market Business Requirements Specification - Planning		Date Created:	1/21/2026

ID#	Business Feature	Requirement Type	Potential Application(s) Impacted
EDAM-BRQ-12070	<p>Set configuration and execution control for day ahead resource sufficiency evaluation (DA-RSE)</p> <ul style="list-style-type: none"> • System shall configure the run time, currently, run advisory DA-RSE every 30 minutes between 6 am and 10 am for each EDAM BAA, run binding RSE after DAM closed at 10am • System shall provide operation execution control, option to manually or automatic perform the DA-RSE, <ul style="list-style-type: none"> ○ Configure the timing of Automatic execution of DA-RSE, default is approximately every 30 minutes, starting at first advisory run 6 am, ending at 10 am for binding run <ul style="list-style-type: none"> ▪ The DA-RSE will automatically run every 30 minutes between 6AM and 9:30AM with the latest consumed dataset ▪ Allow manual run the DA-RSE using the latest consumed dataset for 10 am binding DA-RSE 	Core	DAM DA-RSE
EDAM-BRQ-12080	<p>Run DA-RSE optimization without network</p> <p>Use same optimization model used in IFM with following settings:</p> <ul style="list-style-type: none"> ○ Objective function is to minimize the all surplus variables for each EDAM BAA i.e., all requirements (demand forecast, ancillary services, and uncertainty) to be satisfied • No NA: Exclude transmission related constraints, therefore nor need network application (NA) power flow. • Enforce all scheduling constraint for DA RSE: ITC/ISL/ACC/gas nomogram • Balance each EDAM BAA supply with the adjusted forecast demand and IRU/IRD requirements, and AS requirements. (note: adjust the requirements by counting the RSE eligible capacity and Diversity Benefit) • VER capacity extend to forecast in RSE in whole EDAM footprint 	Core	DAM DA-RSE

 California ISO	Technology	Template Version:	6.8
		Document Version:	6.1.7
Extended Day Ahead Market Business Requirements Specification - Planning		Date Created:	1/21/2026

ID#	Business Feature	Requirement Type	Potential Application(s) Impacted
	<ul style="list-style-type: none"> Optimize EDAM trading day 24 hours with all other constraints, including resource inter-tempo constraints. <p>Note: Virtual bids are not eligible for RSE</p>		
EDAM-BRQ-12090	<p>Run DA-RSE optimization for EDAM BAA in EDAM footprint</p> <ul style="list-style-type: none"> Run DA-RSE optimization for entire EDAM footprint by market operator Not allow the economic transfer between the EDAM BAAs. RSE eligible transfer is preprocessed to move the requirement from sink BAA to source BAA Model each individual BAA constraints for the power balance constraint to meet the demand forecast and meet the AS and IRU/IRD requirements by BAA 	Core	DAM DA-RSE
EDAM-BRQ-12150	<p>Recognize the resources with RSE flag, or with CRN that self-scheduled to count towards DA-RSE</p> <ul style="list-style-type: none"> For all EDAM BAAs, the resource defined in MF with RSE eligible flag, count the resource bid range or self-schedule In addition, for ISO, include bids range system resources (between ISO and non-EDAM BAAs) with RSE flag, Include TG resource that include dynamic resource, network resource and pseudo-tie with RSE flag For VER (with RSE flag in MF) in ISO and EDAM BAAs, use forecast as bid range. <ul style="list-style-type: none"> Create default supply bids if no bid or extend bid-in bids for the difference between the bid-in and forecast quantity for use in the DA-RSE TSRs Type 1 and Type 3 shall count toward RSE 	Core	DAM DA-RSE
EDAM-BRQ-12150a	<p>System Resources (SR) eligibility for RSE</p> <p>For CISO BAA:</p> <ul style="list-style-type: none"> PT exports are RSE eligible LPT and Economic exports are not RSE eligible Wheel PT is RSE eligible <p>Note: applies to Master file defined SR and transaction ID SRs.</p> <p>For EDAM,</p>	Core	DAM DA-RSE

 California ISO	Technology	Template Version:	6.8
		Document Version:	6.1.7
Extended Day Ahead Market Business Requirements Specification - Planning		Date Created:	1/21/2026

ID#	Business Feature	Requirement Type	Potential Application(s) Impacted
	<ul style="list-style-type: none"> All the SRs including Transaction ID, Self-schedule are RSE eligible <p>Note: EDAM BAA import/export reserve the transmission on OATT sales. CAISO does not sell OATT.</p>		
EDAM-BRQ-12160	<p>The resources shall not count towards DA-RSE</p> <ul style="list-style-type: none"> No Convergence bids (CB) for RSE No load resource bids, use demand forecast No transaction ID unless it with CRN SS No optimizable TSR transfer (Implementation detail if we move requirement or SS) RSE eligible TSR limit used to move the requirement from sink to source BAA. 	Process	DAM DA-RSE
EDAM-BRQ-12170	<p>For CISO BAA: Include PT export, PT wheeling through ISO with non-EDAM BAA in RSE</p> <ul style="list-style-type: none"> For Export from CISO BAA: <ul style="list-style-type: none"> PT export self-schedule shall be included in RSE PT wheel only model the wheel through ISO with non-EDAM BAA, include RSE for both PT import/Export (SIBR) <p>Note: EDAM entities seeking to utilize supply that wheels through the ISO system to support their RSE demonstrations would acquire high wheeling through scheduling priority across the ISO system to bring RSE eligible transmission to the EDAM BAA</p> <p>EDAM with PT wheeling will have RSE import and RSE export</p>	Core	DAM DA-RSE
EDAM-BRQ-12180	<p>Identify the BAA the hourly results of success or fail DA-RSE</p> <ul style="list-style-type: none"> RSE will evaluate every constraint listed below if it is relaxed for every BAA for every hour on the horizon. <ul style="list-style-type: none"> Energy Demand and IRU/IRD requirements constraint, upper/down AS procurement constraints The DA-RSE for the BAA is deemed as success if no constraint is relaxed (the surplus variables have positive values) for the hour The DA-RSE for the BAA is deemed as failure if any requirement constraint is relaxed for the hour 	Core	DAM DA-RSE

 California ISO	Technology	Template Version:	6.8
		Document Version:	6.1.7 1.7
Extended Day Ahead Market Business Requirements Specification - Planning		Date Created:	1/21/2026

ID#	Business Feature	Requirement Type	Potential Application(s) Impacted
	<ul style="list-style-type: none"> ○ Calculate the each deficiency (deficiency of energy, IR, AS, upper/down), upper and down separately for each hour 		
EDAM-BRQ-12030	<p>Report DA RSE requirement movement between EDAM BAAs</p> <ul style="list-style-type: none"> • The RSE use RSE eligible TSR limit and TSR associate with CRN that self-scheduled to move the requirement between BAAs, from sink BAA to source BAA effectively by Energy Demand & IR up/down, AS • Display/broadcast the table of requirement movement between BAAs to support bilateral outside trade every 30 minutes between 6 am and 10 am by the transfer capacity for energy and IR, by the self-provision of AS transfer. <p>Note: The RSE requirement movement between BAAs shall be reported on OASIS</p>	Core	DA-RSE
EDAM-TSR-BRQ-12039	<p>TSR RSE eligible capacity limit will transfer the RSE requirement from sink to source</p>	Existing	DA-RSE

 California ISO	Technology	Template Version:	6.8
		Document Version:	6.1.7 1.7
Extended Day Ahead Market Business Requirements Specification - Planning		Date Created:	1/21/2026

5.8 Business Process: Manage DAM (MPM, IFM)

- Accommodate disruption of EDAM BAAs in EDAM
- Consume EDAM entity activated transmission constraints for EDAM BAA from WebOMS
- Extend the DAM local market power mitigation (LMPM) for energy and IRU to each EDAM BAA—DAME
- Co-optimize energy supply/demand, CB, AS, IRU/IRD across the EDAM footprint
- Model EDAM Transfer resource TSR limits—allow TSR transfer energy, AS, IRU/IRD
- Enforce net transfer out limit
- Do not allow simultaneous relaxation of the PBC, IRU/IRD deployment, RCU/RCD and a net export transfer above resource eligible energy exported transfers
- Calculate/broadcast EDAM resource awards and LMPs

5.8.1 Business Requirements

ID#	Business Feature	Requirement Type	Potential Application(s) Impacted
EDAM-BRQ-13020	Consume EDAM entity submitted status of activated/deactivated constraints for EDAM BAA: <ul style="list-style-type: none"> • Get the constraint default status from FNM build for the BAAs participating in EDAM • Consume EDAM entity update to the status of constraint from WebOMS, override the RTM constraint status in DAM <ul style="list-style-type: none"> ○ Flowgate and nomogram constraints for EDAM entities ○ Contingencies ○ Transmission conformance (flowgate limit change) • Consume net export transfer out constraint—EDAM entities activated the net export transfer out constraint for selected hours of the day and corresponding CF and RM from SIBR 	Core	DAM (WebOMS) (SIBR)
EDAM-BRQ-13025	Consume TCOR and ITC limits for EDAM BAAs <ul style="list-style-type: none"> • Receive the EDAM entity submitted limits from PLC for EDAM BAA's <ul style="list-style-type: none"> ○ TCOR ○ ITC ○ 	Core	DAM (PLC)

 California ISO	Technology	Template Version:	6.8
		Document Version:	4.6 1.7
Extended Day Ahead Market Business Requirements Specification - Planning		Date Created:	1/21/2026

ID#	Business Feature	Requirement Type	Potential Application(s) Impacted
EDAM-BRQ-13030	Distribute IRUR/IRDR to EDAM load and VER nodes <ul style="list-style-type: none"> • Use same IRUR/IRDR at 9 am calculated in DA-RSE • Calculate the IRU/IRD requirement allocation factors (AF) to demand, solar, and wind for each hour of the trading day for EDAM BAA based on high/low percentile of demand/solar/wind forecast uncertainty • Distribute the IRUR/IRDR to demand nodes superimposed on the load schedule • Calculate solar and wind Distribution Factors (DF) of each VER node proportional to the forecasts • Distribute the IRU/IRD requirement to VER nodes, superimposed on the VER schedule 	Core DAME	DAM
EDAM-BRQ-13040	Extend to EDAM: Apply IRU/ IRD demand price curve in optimization in MPM and IFM <ul style="list-style-type: none"> • By 10 am, consume the IRU and IRD demand price curves $\{Q_k, P_k, k = 1, 2, \dots, n\}$ for each hour interval of the DAM market horizon for each EDAM BAA • Transform demand price curve to monotonically increasing price curve for surplus variables for IRU/IRD for each hour each BAA • Limit demand price curve by IRU/IRD cap prices 	Core	MPM, IFM
EDAM-BRQ-13050	Suspension of EDAM Entity Participation and Transitional Process: <ul style="list-style-type: none"> • Transitional protection: <ul style="list-style-type: none"> ○ Pursuant to the terms of a Market Notice, temporarily suspend participation of that EDAM Entity in the Day-Ahead Market for a period not to exceed 60 days ○ The EDAM entity suspend from EDAM shall be suspend from the WEIM for the same suspension period ○ The EDAM entity that is suspended will not automatically fall back to NPM ○ The CAISO may continue operation of the Day-Ahead Market without the participation of the suspended EDAM Entity 	Process	DAM

 California ISO	Technology	Template Version:	6.8
		Document Version:	6.1.7
Extended Day Ahead Market Business Requirements Specification - Planning		Date Created:	1/21/2026

ID#	Business Feature	Requirement Type	Potential Application(s) Impacted
EDAM-BRQ-13052	Disruption of EDAM BAA, in similar way as WEIM <ul style="list-style-type: none"> • EDAM Entity can achieve EDAM BAA isolation by not submitting any TSR limits (default TSR limit is zero) • If market operator cannot clear the DAM, all EDAM entities must submit all bids to the RTM • No change to the EDAM entity designation under disruption. Impacted EDAM BAA shall still be an EDAM BAA, subject to EDAM rules. Separated BAA shall not fall back to NPM • Leverage existing processes to address disruption issues, which may include holding the DAM run until issues are resolved 	Process	DAM, RTM
EDAM-BRQ-13052a	Develop procedure for disruption of EDAM BAA <ul style="list-style-type: none"> • EDAM resources continue to bid in the DAM • EDAM Entity can achieve EDAM BAA isolation by not submitting any TSR limits (default TSR limit is zero) • Instruct one or more EDAM Entities to maintain system balance within their Balancing Authority Area without Day-Ahead Market result • Market Operator may publish previous DA results • Market Operator may suspend DAM for all participants and no results will be published—rely on EDs and RTM results • Market Operator may postpone the publication of Day-Ahead Market results • DAM Settlements is applicable to EDAM BAA that is in disruption 	Process	DAM, RTM, Settlements
EDAM-BRQ-13052b	Compare EDAM to WEIM disruption procedure 2720, Procedure 2720 define the WEIM disruption into 4 cases: <ul style="list-style-type: none"> • Market disruption: market fail or result invalid <ul style="list-style-type: none"> ○ This case is applicable to EDAM. If EDAM market fail or result invalid, all EDAM entities must submit all bids to the RTM • Market Suspension: ISO operator suspend the market, use administration price 	Process	DAM, RTM,

 California ISO	Technology	Template Version:	6.8
		Document Version:	6.1.7
Extended Day Ahead Market Business Requirements Specification - Planning		Date Created:	1/21/2026

ID#	Business Feature	Requirement Type	Potential Application(s) Impacted
	<ul style="list-style-type: none"> ○ This case is not applicable to EDAM • Market isolation: limit transfer, still optimal dispatch for the footprint <ul style="list-style-type: none"> ○ This case is not applicable to EDAM. EDAM must allow RSE eligible TSRs • Market separation: limit transfer, no optimal dispatch for the separated BAA. <ul style="list-style-type: none"> ○ 		
EDAM-BRQ-13054	Extend Transitional pricing <ul style="list-style-type: none"> • Extend WEIM transitional pricing measures in EDAM to the same six-month period following onboarding for PBC violations <ul style="list-style-type: none"> ○ Price discovery shall only be applied to PBC (En) 	Core	DAM
EDAM-BRQ-13060	Extend the DAM local market power mitigation (LMPM) for energy and IRU to each EDAM BA <ul style="list-style-type: none"> • Apply LMPM for energy bid by including IRU and IRD deployment scenarios in DCPA counter flow calculation and Energy LMP calculation, use same reference bus as in WEIM for the EDAM BAA • Apply LMPM for IRU bid by including IRU deployment scenarios in DCPA counter flow calculation and IRU nodal price calculation, broadcast mitigated bids 	Core DAME	MPM
EDAM-BRQ-13060a	MPM for Energy at the EDAM BAA level–Trigger DCPA for PBC For each hour, evaluate the EDAM BAAs (non-CAISO BAA) After MPM-IFM run, compare the hourly Marginal Energy Cost (MEC) of each EDAM BAA with the CAISO BAA MEC <ul style="list-style-type: none"> • If (EDAM BAA MEC > CAISO BAA MEC), the EDAM BAA is subject to PBC DCPA test. MEC is the shadow price of BAA power balance constraint (PBC) • If (EDAM BAA MEC ≤ CAISO BAA MEC), the EDAM BAA is not subject to PBC DCPA test 	Core	MPM
EDAM-BRQ-13060b	MPM for Energy at the EDAM BAA level – DCPA for PBC For each hour, for the EDAM BAAs triggered for DCPA, evaluate if EDAM BAA PBC is an uncompetitive constraint, treat	Core	MPM

 California ISO	Technology	Template Version:	6.8
		Document Version:	4.6 1.7
Extended Day Ahead Market Business Requirements Specification - Planning		Date Created:	1/21/2026

ID#	Business Feature	Requirement Type	Potential Application(s) Impacted
	PBC as a binding constraint, use same DCPA calculation as for other binding constraints <ul style="list-style-type: none"> If $RSI < 1$, the EDAM BAA PBC deemed as uncompetitive constraint on hourly basis. Otherwise, the EDAM BAA PBC deemed competitive 		
EDAM-BRQ-13060c	<p>Apply MPM for Energy at the BAA level-LMPM for EDAM resources,</p> <p>Calculate competitive LMP with uncompetitive PBC:</p> <ul style="list-style-type: none"> For the EDAM BAAs have interval uncompetitive PBC, exclude uncompetitive MCC, exclude the differential between EDAM BAA MEC and CAISO MEC from nodal LMP for competitive LMP calculation for all price nodes in the EDAM BAA that apply LMPM in DAM and RTM. For the EDAM BAAs with competitive PBC, exclude uncompetitive MCC from nodal LMP for competitive LMP as currently for all price nodes in the EDAM BAA. Bid mitigation: If $LMP_i^{NC} > Mitigation\ Threshold\ Price$, the resource bid would be mitigated to the higher of the default energy bid (DEB) and its competitive LMP. The bid mitigation apply to all the resources that subject to LMPM. Only mitigate resources that have net positive contribution to the LMP <p>Ex1: For hour h, EDAM BAA MEC is \$25, ISO MEC is \$20, do RSI, if $RSI < 1$, EDAM BAA PBC is uncompetitive EDAM BAA nodal i competitive MCC is \$1. Calculate nodal i competitive LMP \$21. Mitigate every resource at nodal i in EDAM BAA that is higher than max (\$21, DEB)</p> <p>Ex2: For hour h, EDAM BAA MEC is \$25, ISO MEC is \$20, do RSI, if $RSI > 1$, EDAM BAA PBC is competitive EDAM BAA nodal i uncompetitive MCC is \$1. Calculate nodal i competitive LMP \$25. Mitigate every resource at nodal i in EDAM BAA that is higher than max (\$25, DEB)</p> <p>Ex3: For hour h, EDAM BAA MEC is \$25, ISO MEC is \$28, no RSI for PBC, EDAM BAA PBC is competitive EDAM BAA nodal i uncompetitive MCC is \$1. Calculate nodal i competitive LMP \$25. Mitigate every resource at nodal i in EDAM BAA that is higher than max (\$25, DEB)</p>	Core	MPM

 California ISO	Technology	Template Version:	6.8
		Document Version:	6.1.7
Extended Day Ahead Market Business Requirements Specification - Planning		Date Created:	1/21/2026

ID#	Business Feature	Requirement Type	Potential Application(s) Impacted
EDAM-BRQ-13060d	Apply MPM for IRU at the BAA level, similar method as for Energy <ul style="list-style-type: none"> ○ Trigger for IRU DCPA: After MPM-IFM run, if the hourly Marginal IRU Cost (ρ_t) of each EDAM BAA > CAISO BAA ρ_t ○ IRU DCPA: Same uncompetitive paths as $RSI_{m,t}^{(u)} < 1$ ○ Calculate Competitive $IRUMP_{i,t}$ Exclude uncompetitive MCC and the differential between EDAM BAA (ρ_t) and ISO (ρ_t) from locational price of IRU <ul style="list-style-type: none"> • <i>Mitigate</i> the resource IRU bid to the higher of the default IRU bid (DAB= \$55) and its competitive $IRUMP_{i,t}$ 	Core	MPM
EDAM-BRQ-13061	Include GHG constraint in LMPM <ul style="list-style-type: none"> • Use the same GHG constraint in IFM and MPM, include resource GHG reference point (from GHG pass) in GHG constraint • GHG bids are not subject to mitigation 	Core	MPM
EDAM-BRQ-13062	Extend storage DEB to EDAM storage resource <ul style="list-style-type: none"> • Non-CAISO EDAM resources can now use the Storage DEB option in DAM and RTM 	Core	IFM/RTM
EDAM-BRQ-13070	Co-optimization for Energy supply/demand, CB, AS, IRU/IRD across EDAM footprint <p>The IFM will optimally procure Energy, IRU/IRD across the EDAM footprint; AS for ISO, CB for opt-in BAAs, and GHG allocation with resource bids and network constraints:</p> <ul style="list-style-type: none"> • Set up PBC and IRU/IRD requirement constraints for each specific BAA, no EDAM footprint PBC constraint, use same requirements that include diversity benefit used in RSE 9 am run. • Enforce self-schedule energy, and self-provision of AS, do not enforce AS constraint for non-ISO EDAM BAAs • Co-Optimize : <ul style="list-style-type: none"> • Energy supply bids and demand bids, include system resource bids • IRU/IRD bids 	Core	IFM

 California ISO	Technology	Template Version:	6.8
		Document Version:	6.1.7
Extended Day Ahead Market Business Requirements Specification - Planning		Date Created:	1/21/2026

ID#	Business Feature	Requirement Type	Potential Application(s) Impacted
	<ul style="list-style-type: none"> Convergence bids of supply and demand for ISO and EDAM BAAs that opt-in CB, AS bids for ISO, GHG bids from resources Extend/enforce all IFM resource limits and network constraints to EDAM. 		
EDAM-BRQ-13080	<p>Model EDAM Transfer resource constraints:</p> <ul style="list-style-type: none"> Enforce the transfer limit of all TSR limits to support energy, fixed AS, IRU/IRD in IFM, the downward capacity awards of IRD and RegD shall not provide counter flow. See the limit constraint in BRQ-13080a All TSR capacities are available for market optimal transfer for any commodity. The TSR attribute RSE eligibility and RSE commodity other than AS will be ignored in IFM The transfer awards to TSR for Energy, AS, IRU, IRD. One TSR can have multiple commodity awards. Apply to the schedule priority for the resource and TSR with CRN, only balanced self-schedules have schedule priority, with order of TOR, ETC, OATT, by penalty cost <ul style="list-style-type: none"> Released capacity, regardless of CRN, will not have schedule priority 	Core	IFM
EDAM-BRQ-13090	<p>Apply demand price curve for IRU/IRD</p> <ul style="list-style-type: none"> Consume and transform (flip) demand price curve to monotonically increasing price curve Apply BAA demand price curve for IRU/IRD; relax on IRU/IRD surplus variables in optimization to procure IRU/IRD <ul style="list-style-type: none"> In the IFM the IRU/IRD requirement will be relaxed economically before the PBC is relaxed. 	Core DAME	IFM
EDAM-BRQ-13095	<p>Broadcast BAA that failed PBC and are out of the EDAM Pool</p> <p>If the EDAM BAA have non-zero relaxation (positive/negative) in Power Balance Constraint (PBC) in IFM</p> <ul style="list-style-type: none"> Deem the BAA not cured by the market 	Core	IFM

 California ISO	Technology	Template Version:	6.8
		Document Version:	6.1.7
Extended Day Ahead Market Business Requirements Specification - Planning		Date Created:	1/21/2026

ID#	Business Feature	Requirement Type	Potential Application(s) Impacted
	<ul style="list-style-type: none"> Exclude the BAA from the EDAM upward pool if the PBC relaxed variable is positive in IFM or RUC. Exclude the BAA from the EDAM downward pool if the PBC is relaxed variable is negative in IFM or RUC. 		
EDAM-BRQ-13096	The EDAM pool <ul style="list-style-type: none"> EDAM BAAs with zero relaxation in PBC will form a pool in RTM RSE if the BAAs tag the schedules or resupply. 	Process	IFM
EDAM-BRQ-13099	Build activate/deactivate configurable parameter for net transfer out constraint <ul style="list-style-type: none"> The activate/deactivate system parameter shall apply to DAM, IFM, and RUC 	Core	DAM, IFM, RUC
EDAM-BRQ-13100	Enforce Net EDAM Export Transfer Constraint <ul style="list-style-type: none"> Consume confidence factor (CF) from SIBR Consume hourly reliability margin (RM) from SIBR Consume EDAM entity submitted BAA level hourly activate flag from SIBR Market shall enforce hourly net transfer out limit for energy, IRU, and IRD <ul style="list-style-type: none"> (RSE Eligible Supply + Non RSE Eligible Supply x Confidence Factor) – RSE Obligation – Additional Margin The constraint uses the RSE awards to calculate the available capacity In RUC: Market shall enforce hourly net transfer out limit for (energy + IRU – IRD + RCU) Notes: <ul style="list-style-type: none"> Stressed hour shall only be reported for ISO BAA 	Core	IFM, RUC (from SIBR)
EDAM-BRQ-13120	Do not allow simultaneous relaxation (supply shortfall/surplus) of the power balance constraint and a net export/import transfer above RSE eligible energy transfers <ul style="list-style-type: none"> The IFM will not allow a net export energy transfer above a reference to cause power balance shortfall, or a net import energy transfer below a reference to cause power balance surplus. The net transfer reference is the RSE-eligible net transfer 	Core	IFM

 California ISO	Technology	Template Version:	6.8
		Document Version:	6.1.7 1.7
Extended Day Ahead Market Business Requirements Specification - Planning		Date Created:	1/21/2026

ID#	Business Feature	Requirement Type	Potential Application(s) Impacted
	<p>Note: Imbalance reserve balance relaxation constraints are not required in the IRU/IRD deployment scenarios because of the economic relaxation of the IRU/IRD requirements provided by the IRU/IRD surplus</p> <p>Note: Model as the slack variable of PBC balance (Positive as short of supply) cannot be the same direction as net transfer above RSE eligible energy transfer</p>		
EDAM-BRQ-13140	<p>Do not allow simultaneous relaxation of the RCU/RCD procurement constraint and a net export transfer above RSE eligible RCU/RCD exported transfers</p> <ul style="list-style-type: none"> The RUC will not allow the simultaneous relaxation of the reliability capacity procurement constraint and a net reliability capacity export transfer 	Core	RUC
EDAM-BRQ-13150	<p>Model system resource (SR) with unknown location at super DGAP (SDGAP) as injection location</p> <ul style="list-style-type: none"> Consume SR with unknown location association with scheduling point (SP) and super DGAP The system resource that include the SP with association to non-EDAM super DGAP (SDGAP) will use DGAP as injection location in the DAM, LMP for the system resource will be formed according to the DGAP. <ul style="list-style-type: none"> Market shall renormalize GDF to account for outages 	Core	DAM
EDAM-BRQ-13152	<p>Model ITC/ISL at Scheduling Point (SP) of system resource that inject at super DGAP</p> <p>Include system resource with injection defined at DGAP in the ITC/ISL constraint that apply to corresponding intertie SP</p>	Core	DAM
EDAM-BRQ-13160	<p>Extend to EDAM: hourly LMP for energy and IRU/IRD to EDAM location and resource</p> <ul style="list-style-type: none"> Calculate hourly locational marginal price (LMP) for energy in DAM, include IRU/IRD deployment scenarios on congestion for nodal and resource <ul style="list-style-type: none"> Include Gas nomogram shadow price for resource only Calculate hourly SP-Tie LMP for energy in DAM include IRU/IRD deployment scenarios on congestion as 	DAME	DAM

 California ISO	Technology	Template Version:	6.8
		Document Version:	6.1.7
Extended Day Ahead Market Business Requirements Specification - Planning		Date Created:	1/21/2026

ID#	Business Feature	Requirement Type	Potential Application(s) Impacted
	normal nodal LPM plus shadow price of ITC/ISL for nodal and resource <ul style="list-style-type: none"> • Calculate hourly nodal IRU marginal price (IRUMP) in DAM for nodal and resource • Calculate hourly nodal IRD marginal price (IRDMP) in DAM for node and resource • Calculate hourly SP-tie IRU marginal price (IRUMP) in DAM for nodal and resource • Calculate hourly SP-tie IRD marginal price (IRDMP) in DAM for nodal and resource 		
EDAM-BRQ-13161	Extend to EDAM: hourly IRU/IRD surplus value, LMP and components for EDAM BAA <ul style="list-style-type: none"> • Access Associated Imbalance Demand Hub Apnode of each BAA from MF • Calculate BAA Imbalance Upward/Downward deployment Shift Factors Imbalance demand reference point (Anode) • Include IRU/IRD awards, demand and surplus contribution in transmission constraint • Calculate hourly IRU/IRD Surplus variable and IRU/IRD marginal price at location (Apnode) associated with the BAA Imbalance Demand Hub, including price breakdowns per BAA per PIME logic • Broadcast hourly IRU/IRD Surplus variable and IRU/IRD marginal price of Imbalance Demand Hub Apnode, including price breakdowns by BAA. 	DAME	DAM
EDAM-BRQ-13162	Calculate the energy LMP and IRU/IRD MP for the transfer resource (TSR) <ul style="list-style-type: none"> • Calculate energy LMP for TSRs to include all components (MEC, MCL, and MCC) similar to SP-Tie, but without MCG <ul style="list-style-type: none"> ○ For MCL, the marginal loss rate between the two TSRs for a given transfer will be averaged so that there is no marginal loss contribution to transfer revenue. • Calculate IRU/IRD LMP for TSRs. The TSR IR/RC MP is the same as energy, but without MCL for IR, thus only 	Core	DAM, RTM

 California ISO	Technology	Template Version:	6.8
		Document Version:	4.6 1.7
Extended Day Ahead Market Business Requirements Specification - Planning		Date Created:	1/21/2026

ID#	Business Feature	Requirement Type	Potential Application(s) Impacted
	marginal price for IRU/IRD procurement for the BAA attached to, and marginal congestion contributions and SP-Tie, without MCG		
EDAM-BRQ-13200	Extend to EDAM: Broadcast resource awards, LMP, shadow prices and other DAM results, Include MCC Component by BAA in LMP Breakdown <ul style="list-style-type: none"> • Broadcast Resource Awards for Energy, IRU/IRD, AS, same manner as DAM for ISO • Broadcast nodal/resource price for energy, IRU/IRD, price for AS, same manner as DAM for ISO • Broadcast all the resources (include the ISO and EDAM BAA, physical and virtual bids) Shift factors on the binding constraint, same as ISO • Broadcast the shadow price of each binding constraint and associated BAA; same as DAM for ISO • Broadcast IFM LMP for defined Load Aggregated Points (LAP), from physical and virtual load weighted average • Broadcast CRN ID and Type, associated with MW quantity award (to distinguish between ETC and OATT) 	Core	DAM, RTM
EDAM-BRQ-13210	Calculate LMP energy components (MEC) for each BAA <ul style="list-style-type: none"> • The LMP energy component (MEC) will be each BAA dependent • For the EDAM BAA nodal price LMP, use the BAA power balance constraint shadow price as MEC Note: The LMP MEC calculation is changed from previous methodology using ISO PBC as MEC. This change applies to DAM and RTM	Core	DAM, RTM
EDAM-BRQ-13285	Extend to EDAM: Calculate Hourly SP-Tie IRU Marginal Price (IRUMP) in DAM for Resource <ul style="list-style-type: none"> • SP nodal price of IRU • (plus) the shadow prices of import direction of all binding Intertie Scheduling Limits (ISLs) and Inter-Tie Constraints (ITCs) associated with that SP-Tie Location of IRU for import resources and TG • (minus) the shadow prices of export direction of all binding Intertie Scheduling Limits (ISLs) and Inter-Tie Constraints 	Core	IFM, IFM-MPM

 California ISO	Technology	Template Version:	6.8
		Document Version:	6.1.7
Extended Day Ahead Market Business Requirements Specification - Planning		Date Created:	1/21/2026

ID#	Business Feature	Requirement Type	Potential Application(s) Impacted
	(ITCs) associated with that SP-Tie Location of IRU for export resources Note Refer to DAME-BRQ-04395		
EDAM-BRQ-13290	Calculate Hourly SP-Tie IRD Marginal Price (IRDMP) in DAM for Resource <ul style="list-style-type: none"> • SP nodal price IRD • (plus) the shadow prices of the import directions of all binding Intertie Scheduling Limits (ISLs) and Inter-Tie Constraints (ITCs) associated with that SP-Tie Location of IRD for export resources • (minus) the shadow prices of the export directions of all binding Intertie Scheduling Limits (ISLs) and Inter-Tie Constraints (ITCs) associated with that SP-Tie Location of IRD for import resources and TG Note: Refer to DAME-BRQ-04405	Core	IFM, IFM-MPM
EDAM-TSR-BRQ-12043	Assign Transfer Cost to Transient TSRs <ul style="list-style-type: none"> • Assign default transfer cost (configurable) to each type of transient TSRs <ul style="list-style-type: none"> ○ Type 1: 0.0001 ○ Type 2: 0.0003 ○ Type 3: 0.0002 ○ Type 4: 0.0004 • Note that Type 2 transfer cost is higher than Type 3 Note: Type 1 has highest priority as they are based off CRNs and self-scheduled firm transmission. Type 3 has the second highest priority because these are based-off contracted obligations with firm transmission (RSE eligible). Type 2 has the third highest priority because these represent customer purchased firm transmission. Type 4 has the lowest priority because these represent unsold/unused transmission.	Core	IFM/RTM
EDAM-TSR-BRQ-12044	Include TSRs in ITC <ul style="list-style-type: none"> • The system will support both intertie (formerly scheduling point) and transfer locations in the ITC definition 	Core	DAM/RTM

 California ISO	Technology	Template Version:	6.8
		Document Version:	4.6 1.7
Extended Day Ahead Market Business Requirements Specification - Planning		Date Created:	1/21/2026

ID#	Business Feature	Requirement Type	Potential Application(s) Impacted
	<ul style="list-style-type: none"> The system shall use the Transfer Location to ITC mapping to include TSRs generated in SIBR into the relevant ITC constraint Include all TSRs (both MF registered and SIBR generated) using their Transfer Location mapping to ITC 		
EDAM-TSR-BRQ-12045b	<p>Validation for any TSR schedule change received from RTSI</p> <ul style="list-style-type: none"> The system shall not allow a schedule change to exceed the Maximum Capacity of the TSR If the sum of the Type 1 TSR schedules, including RTSI schedule updates, plus Released Capacity, for a TCSC, CRN, and Transfer Location, exceeds the CRN Capacity for that TCSC, CRN, and Transfer Location, the system shall associate each energy schedule with the CRN pro rata so that the sum of the associations and the Released Capacity is limited to the CRN Capacity (see example in notes) Notify validation outcome to EESC via BAAOP <p>Notes:</p> <ul style="list-style-type: none"> TSR Maximum Capacity may be updated in SIBR by EESC before T-75 <p>Example:</p> <ul style="list-style-type: none"> E.g., CRN Capacity = 100 MW Released Capacity= 20 MW SIBR SS1=40 MW SIBR SS2=20 MW RTSI1 SS Update= 70 MW RTSI2 SS Update= 30 MW Rule: 70+30+20>100 MW CRN Capacity, therefore: <ul style="list-style-type: none"> RTSI SS1 association with CRN=(0.7*80)=56 MW RTSI SS2 association with CRN= (0.3*80)=24 MW RTSI SS1 NOT associated with CRN= (70-56)=14 MW RTSI SS2 NOT associated with CRN= (30-24)=6 MW Total scheduled=80 MW 	Core	RTPD (RTSI)

 California ISO	Technology	Template Version:	6.8
		Document Version:	6.1.7 1.7
Extended Day Ahead Market Business Requirements Specification - Planning		Date Created:	1/21/2026

ID#	Business Feature	Requirement Type	Potential Application(s) Impacted
	<ul style="list-style-type: none"> ○ Released Capacity remains at 20 MW 		
EDAM-TSR-BRQ-12046	Publish TSR/ETSR Awards, Prices, and Schedules <ul style="list-style-type: none"> • TSR/ETSR prices shall reflect the FROM_BAA MEC and ITC shadow price 	Core	IFM/RTM
EDAM-TSR-BRQ-12047	Calculate MCC Prices, LMPs and MCC Breakdown for Energy, IRU/IRD, and RCU <ul style="list-style-type: none"> • For Energy: Transfer Location APNode price will be calculated as the Transfer Location FROM_BAA's MEC plus applicable ITC shadow price including MCC breakdown by BAA • For IRU/IRD: Transfer Location APNode price will be calculated as the Transfer Location FROM_BAA's IRU/IRD procurement shadow price plus applicable ITC shadow price including MCC breakdown by BAA • For RCU: Transfer Location APNode price will be calculated as the Transfer Location FROM_BAA's RCU MEC shadow price of the PBC plus applicable ITC shadow price including MCC breakdown by BAA 	Core	IFM/RTM
EDAM-DARA-BRQ-641	CISO OE conduct Nomogram conformance to ISO and EDAM BAA <ul style="list-style-type: none"> • CISO Operation Engineer can update nomogram conformance for EDAM through market UI, default is 100% <ul style="list-style-type: none"> ○ Nomogram conformance for EDAM should be visible and editable in DAM <p>CISO OE must communicate with EDAM entity before updating</p>	Existing	DAM, RTM
EDAM-DARA-BRQ-642	CISO Operations Engineering shall build MOC for EDAM BAA in the DAM <ul style="list-style-type: none"> • Based on EDAM, through OMS, submitted MOC free text, RTMO will work with EDAM entity, <ul style="list-style-type: none"> ▪ Build Minimum On-line Constraint (MOC) definition for the EDAM BAA <p>Activate the MOC according to EDAM submitted instruction</p>	Process	DAM

 California ISO	Technology	Template Version:	6.8
		Document Version:	6.1.7 1.7
Extended Day Ahead Market Business Requirements Specification - Planning		Date Created:	1/21/2026

5.9 Business Process: Manage RUC (RUC, DAM TD+X)

- Extend RUC for RCU/RCD to EDAM
- Calculate RCU/RCD transfers awards and prices
- Extended VER capacity to VER forecasts
- Do not allow the simultaneous relaxation of the reliability capacity procurement constraint and a net reliability capacity export transfer
- Enforce net transfer out limit in RUC
- Run TD+X DAM market with re-optimization for energy, AS for ISO, IRU, IRD

5.9.1 Business Requirements

ID#	Business Feature	Requirement Type	Potential Application(s) Impacted
EDAM-BRQ-14010	Extend RUC for RCU to EDAM, model RCU/RCD transfers: <ul style="list-style-type: none"> • Define notion $REN=EN+RCU-RCD$ for each EDAM BAA resource • Include TSR for RCU capacity in the EDAM BAAs transfer limit constraints that include IFM awards for all commodities, allow Energy counter flow. • Assign transfer cost to each transfer in the objective function. To favor RCU transfers in that distribution, the transfer cost for RCD should be set slightly higher than the transfer cost for RCU. • Build RUC-MPM, apply LMPM for RCU, and broadcast mitigated RUC bids • Apply mitigated RUC bids for 24 hours • Procure RCU/RCD through optimization • Fixed AS and IRU/IRD IFM awards, no CB, no GHG model • Model MSG transition in RUC 	Core DAME	RUC
EDAM-BRQ-14012	VER capacity extended to VER forecast <ul style="list-style-type: none"> • VER capacity shall be extended to the VER forecast in RUC for EDAM VER resources 	Core	RUC
EDAM-BRQ-14014	Apply MPM for RCU at the BAA level, similar as for Energy <ul style="list-style-type: none"> • Trigger for RCU DCPA: After RUC MPM run, if the hourly Marginal RCU Cost (RUC MEC) of each EDAM BAA > CAISO BAA Marginal RCU Cost (RUC MEC) 	Core	RUC

 California ISO	Technology	Template Version:	6.8
		Document Version:	4.61.7
Extended Day Ahead Market Business Requirements Specification - Planning		Date Created:	1/21/2026

ID#	Business Feature	Requirement Type	Potential Application(s) Impacted
	<ul style="list-style-type: none"> Calculate RSI, if $RSI < 1$, the BAA RUC PBC deemed uncompetitive for the hour Calculate Competitive $RCUMP_{i,t}$ for uncompetitive RUC PBC Exclude uncompetitive MCC and the differential between EDAM BAA RCU MP and ISO RCU MP from locational price of IRU <p>Mitigate the resource IRU bid to the higher of the default RCU bid (DAB= \$55) and its competitive $RCUMP_{i,t}$</p>		
EDAM-BRQ-14020	<p>Do not allow the simultaneous relaxation of the power balance constraint and a net reliability capacity export/import transfer</p> <ul style="list-style-type: none"> Do not allow a net export reliability capacity transfer above a reference to cause power balance shortfall, or a net import reliability capacity transfer below a reference to cause power balance surplus. The net transfer reference includes the energy and IRU/IRD net transfers from the IFM 	Core	RUC
EDAM-BRQ-14030	<p>Enforce net transfer out limit in RUC</p> <ul style="list-style-type: none"> Base on the EDAM BAA option flag Market shall enforce hourly limit for (energy + IRU – IRD + RCU) as max of (difference between countable capacity and the RSE requirement for the EDAM BAA, RSE eligible transfer out) 	Core	RUC
EDAM-BRQ-14042	<p>Calculate RCU LMP for RUC transfer TSR</p> <ul style="list-style-type: none"> Calculate RUC LMP for TSRs to include all components (MEC, MCL, and MCC) similar to SP-Tie, but without MCG. <ul style="list-style-type: none"> For MCL, the marginal loss rate between the two TSRs for a given transfer will be averaged so that there is no marginal contribution to transfer revenue 	Core	RUC
EDAM-BRQ-14055	<p>Extend to EDAM: Calculate Hourly SP-Tie RCU Marginal Price (RCUMP) in DAM for Resource</p> <ul style="list-style-type: none"> SP nodal price of RCU (plus) the shadow prices of import directions of all binding Intertie Scheduling Limits (ISLs) and Inter-Tie Constraints 	Core	RUC

 California ISO	Technology	Template Version:	6.8
		Document Version:	6.1.7 1.7
Extended Day Ahead Market Business Requirements Specification - Planning		Date Created:	1/21/2026

ID#	Business Feature	Requirement Type	Potential Application(s) Impacted
	(ITCs) associated with that SP-Tie Location of RCU for import resources and tie-gen (TG) <ul style="list-style-type: none"> (minus) the shadow prices of export directions of all binding Intertie Scheduling Limits (ISLs) and Inter-Tie Constraints (ITCs) associated with that SP-Tie location of RCU for export resources <p>Note Refer to DAME-BRQ-05181</p>		
EDAM-BRQ-14056	<p>Extend to EDAM: Calculate Hourly SP-Tie RCD Marginal Price (RCDMP) in DAM for Resource</p> <ul style="list-style-type: none"> SP nodal price RCD (minus) the shadow prices of export directions of all binding Intertie Scheduling Limits (ISLs) and Inter-Tie Constraints (ITCs) associated with that SP-Tie location of RCD for import resources and tie gen (TG) (plus) the shadow prices of import directions of all binding Intertie Scheduling Limits (ISLs) and Inter-Tie Constraints (ITCs) associated with that SP-Tie Location of RCD for export resources <p>Note Refer to DAME-BRQ-05183</p>	Core	RUC
EDAM-BRQ-14060	<p>Run D+X EDAM same as D+1 EDAM with corresponding bids and forecast</p> <ul style="list-style-type: none"> Run D+X study case same as DAM for D+1, no change to market products co-optimization, network, and schedule constraints enforcements <ul style="list-style-type: none"> Able to run all DAM passes The D+X runs use everything as close as possible to D+1 today. Use D+X bids for energy, AS. IRU/IRD in IFM, RCU/RCD bids in RUC if MP submitted bids in advance, otherwise <ul style="list-style-type: none"> Allow user to use copy of the D+1 bids or same-day bids Use latest submitted outages 	Process	DAM

 California ISO	Technology	Template Version:	6.8
		Document Version:	6.1.7 1.7
Extended Day Ahead Market Business Requirements Specification - Planning		Date Created:	1/21/2026

ID#	Business Feature	Requirement Type	Potential Application(s) Impacted
	<ul style="list-style-type: none"> Use transfers submitted scheduling limits for D+X, use D+1 limits or same-day limits if not submitted Support schedule priority for the resource with CRN with valid self-schedule 		
EDAM-BRQ-14062	<p>Run D+X EDAM with the D+X demand forecast and D+X requirements for AS, IRU, IRD</p> <ul style="list-style-type: none"> Consume the BAA load forecasts for D+X Consume the BAA VER forecasts for D+X Consume and use latest BARC estimated parameters of the same day type of D+X for IRU/IRD Calculate the requirement for BAA IRU/IRD for D+X Calculate D+X AS requirements for ISO Consume EDAM BAA submitted D+X, AS requirement, if not submitted, use the latest day AS requirement and self-provision or same day AS requirement self-provision of the BAA 	Core	DAM
EDAM-BRQ-14074	<p>Extend to EDAM: Model GAS Nomogram and broadcast report of Gas Burn for D+X</p> <ul style="list-style-type: none"> Allow EDAM entity model multiple GAS nomograms in IFM, RUC, RTPD in same manner as for ISO <ul style="list-style-type: none"> Define Gas company, transmission zone and corresponding resources association Define the coefficients for each resource in the Gas nomogram Define the nomogram curve Allow EDAM entity to activate the Gas nomogram through WebOMS Calculate/Broadcast the Gas burn report <ul style="list-style-type: none"> Gas burn summary report by Gas company, by transmission zone Gas burn detail report by resource <p>Notes</p> <ul style="list-style-type: none"> The Gas report for each EDAM entity will broadcast to CMRI. 	Existing	SMDM, IFM, RUC, RTPD

 California ISO	Technology	Template Version:	6.8
		Document Version:	4.6 1.7
Extended Day Ahead Market Business Requirements Specification - Planning		Date Created:	1/21/2026

ID#	Business Feature	Requirement Type	Potential Application(s) Impacted
	<ul style="list-style-type: none"> This requirement is referring only to the technical software capabilities to establish a gas nomogram. The CAISO would like to clarify that that gas nomograms require FERC approval and several business processes to be completed. Should an EDAM/WEIM entity wish to register a gas nomogram, this would require FERC approval. This requirement will not add any new functionality to enable gas nomograms for EDAM/WEIM entities, either in Market or in WebOMS. 		

 California ISO	Technology	Template Version:	6.8
		Document Version:	4.6 1.7
Extended Day Ahead Market Business Requirements Specification - Planning		Date Created:	1/21/2026

5.10 Business Process: Manage Tagging DAM Schedules and resupply (RTSI, ITS, SIBR)

- Facilitate SC submission of tags at 3 hours post-DAM and TH-5h in RTM for DAM import/export and transfer TSR awards/schedules
- Calculate import/export tag shortfalls for EDAM BAAs in the EDAM pool 3 hours after DAM
- Calculate trading hour (TH) import/export tag shortfalls and resupply for EDAM BAAs in the EDAM pool by TH-5hr
- Verify EDAM BAA resupply to cover the import tag shortfall at TH-5 hour for the TH
- The EDAM downward pool includes all EDAM BAAs. No tag validation on export direction
- For the TSR with CRNs, allow EDAM entities and ISO to submit self-scheduled TSR

5.10.1 Business Requirements

ID#	Business Feature	Requirement Type	Potential Application(s) Impacted
EDAM-BRQ-15010	<p>Timing for SC to submit tags for DAM awards/schedules:</p> <ul style="list-style-type: none"> • 3 hours after DAM: System shall consume EDAM entity SC or resource SC submitted schedule and/or transmission profile tag for DAM award/schedule by either 4 pm or within 3 hours of DAM posted results. Note: The ISO market operator will broadcast the report for DAM tag after consumed tags. • By TH-5 hour: <ul style="list-style-type: none"> ○ System shall continue to accept DAM schedule and/or transmission profile tag until (T-5 hour) for counting in EDAM pool eligibility assessment for the trading hour <p>Note: The market system will evaluate BAA eligibility for EDAM pools based on the tags submitted for DAM schedules.</p>	Process	RTSI for EDAM ITS for ISO
EDAM-BRQ-15020	<p>EDAM entity shall Tag hourly Intertie schedule between EDAM and non-EDAM BAAs</p> <p>EDAM entity SC shall submit:</p> <ul style="list-style-type: none"> • The hourly energy schedule and transmission profile tag for DAM self-scheduled import/export energy schedules between EDAM and non-EDAM BAAs • The hourly transmission profile tag for DAM self-provision ancillary service (AS) capacity between EDAM and non-EDAM BAAs 	Process	RTSI

 California ISO	Technology	Template Version:	6.8
		Document Version:	4.61.7
Extended Day Ahead Market Business Requirements Specification - Planning		Date Created:	1/21/2026

ID#	Business Feature	Requirement Type	Potential Application(s) Impacted
	<ul style="list-style-type: none"> The hourly energy schedule or transmission profile tag for DAM self-schedule or awards of energy dynamic schedules and OATT network resources (TG) 		
EDAM-BRQ-15030	<p>ISO resource SC shall tag hourly intertie energy between CAISO and non-EDAM BAAs in e-tagging system</p> <p>Import/Export Resource SC of CAISO shall submit:</p> <ul style="list-style-type: none"> The tag for DAM self-scheduled import/export energy schedules between EDAM and non-EDAM BAAs The tag for DAM self-schedule or awards of energy dynamic schedules and OATT network resources (TG) 	Existing DAME	ITS
EDAM-BRQ-15040	<p>EDAM entity SC or resource SC shall submit approved tags for DAM hourly TSR awards for energy</p> <p>All TSR DAM energy awards shall be tagged for energy profile between EDAM BAAs</p> <ul style="list-style-type: none"> The tag shall be sum of all import, excluding wheels and pseudo tie tag, associated with the from BAA and to BAA IDs that are defined the Master File or SIBR Tagged energy profile 	Process	EDAM scheduling system
EDAM-BRQ-15050	<p>External EDAM Entity shall Tag hourly TSR awards for energy for ISO in e-tagging system</p> <p>Between the ISO BAA and EDAM BAA in the EDAM footprint</p> <ul style="list-style-type: none"> Tag energy profile for DAM TSR energy awards 	External Process	EDAM Entity Tagging System
EDAM-BRQ-15060	<p>Calculate the gross tagged energy import for CISO twice, at 3 hour after DAM awards are consumed and at T-5HR of real time</p> <ul style="list-style-type: none"> Calculate the hourly gross energy import tagged include import and TSR import for the ISO <ul style="list-style-type: none"> Exclude wheeling tags and pseudo tie tags Each time the value is calculated the most recent submitted tags, in approved and pending approval state, will be considered 	Existing	ITS
EDAM-BRQ-15062	<p>Calculate the gross tagged energy import for the EDAM BAA</p> <ul style="list-style-type: none"> Calculate the hourly gross energy import tagged- include import and TSR import for the EDAM BAA <ul style="list-style-type: none"> Exclude wheeling tags and pseudo tie tags 	Process	EDAM scheduling system

 California ISO	Technology	Template Version:	6.8
		Document Version:	4.6 1.7
Extended Day Ahead Market Business Requirements Specification - Planning		Date Created:	1/21/2026

ID#	Business Feature	Requirement Type	Potential Application(s) Impacted
	<ul style="list-style-type: none"> Each time the value is calculated the most recent submitted tags, in approved and pending approval state, will be considered 		
EDAM-BRQ-15063	<p>System shall provide a new submit service to allow the external entity to submit the gross tagged energy import for EDAM BAA after the value is calculated</p> <ul style="list-style-type: none"> The submitted value is the gross energy import tagged for the EDAM BA by hour The gross import data should be submitted at least twice: at 3 hours after DAM award publication for all trading hours and at TH-5 hour for the trading hour. 	Core	SIBR
EDAM-BRQ-15069	<p>Consume Gross Energy Import by BAA</p> <ul style="list-style-type: none"> Data from EDAM entity will be submitted directly to RTSI then broadcasted to the system Data from CISO BA will be broadcasted by ITS and consumed by the system 	Core	SIBR
EDAM-BRQ-15070	<p>Calculate gross hourly energy import schedule upon receiving DAM awards</p> <ul style="list-style-type: none"> The system shall calculate the DAM gross hourly energy import schedule for each EDAM BAA and ISO <ul style="list-style-type: none"> Import between EDAM BAA (include ISO) and non-EDAM BAA, and Transfers in TSR between EDAM BAAs (include ISO) Exclude wheel and pseudo-tie type award 	Core	SIBR
EDAM-BRQ-15071	<p>Calculate the tag shortfalls for each CISO and EDAM BAA twice, at 3 hours after DAM awards are broadcasted and at T-5HR of real time</p> <ul style="list-style-type: none"> System shall calculate the shortfall as the difference between aggregate energy import awards and aggregate import based on tags <p>Note: $\max(0, \text{schedule-import tag})$ is considered shortfall</p>	Core	SIBR
EDAM-BRQ-15110	<p>System shall calculate supply bid coverage by EDAM Entity BA and ISO market, at T-5HR of real time</p> <ul style="list-style-type: none"> For entities that passed shortfall test (shortfall=0), the resupply test should be auto passed 	Core	SIBR

 California ISO	Technology	Template Version:	6.8
		Document Version:	6.1.7
Extended Day Ahead Market Business Requirements Specification - Planning		Date Created:	1/21/2026

ID#	Business Feature	Requirement Type	Potential Application(s) Impacted
	<ul style="list-style-type: none"> • For entities that failed shortfall test (shortfall>0): <ul style="list-style-type: none"> ○ Calculate the sum of the supply energy bid range above the day-ahead schedule (IFM Energy + IRU+RCU) <ul style="list-style-type: none"> ▪ Not encumbered by UPWARD capacity awards ○ Resupply passed if the resupply ≥ shortfall ○ Resupply failed if the resupply < shortfall 		
EDAM-BRQ-15130	Broadcast import tag shortfalls by hour by BAAs at 3 hour after DAM awards are consumed <ul style="list-style-type: none"> • Gross import tagged • Tag shortfall test amount (0 if the tagged import covers schedules) • Tag shortfall test results (PASS/FAIL) 	Core	SIBR
EDAM-BRQ-15132	Broadcast import tag shortfalls and resupply results by BAAs at TH-5HR of TH <ul style="list-style-type: none"> • Gross import schedule • Gross import tagged • Tag shortfall test amount (0 if the tagged import covers schedules) • Tag shortfall test results (PASS/FAIL) • Bid coverage supply • Bid coverage resupply coverage shortfall amount (0, if the resupply covers shortfall) • Bid coverage resupply coverage test results (PASS/FAIL) 	Core	SIBR
EDAM-BRQ-15134	Exclude the EDAM pool tagging and resupply test for the BAAs which have already been dropped out of the EDAM pool due to PBC infeasibilities in IFM or RUC for that hour of failure	Core	SIBR
EDAM-BRQ-15140	For the TSR with CRN, EDAM entity will submit late schedule changes as an update to RTSI of the TSR in RTM For the TSR associated with CRN: <ul style="list-style-type: none"> • The OATT transmission owner can do this through an eTag associated with the CRN up to their rights 	Business Process	RTSI

 California ISO	Technology	Template Version:	6.8
		Document Version:	6.1.7
Extended Day Ahead Market Business Requirements Specification - Planning		Date Created:	1/21/2026

ID#	Business Feature	Requirement Type	Potential Application(s) Impacted
	<ul style="list-style-type: none"> • The EDAM entity should verify that the late schedule change does not exceed the CRN entitlement • The EDAM entity shall submit the self-schedule for the TSR on behalf of transmission right owner <ul style="list-style-type: none"> ○ RTSI shall consume and broadcast submitted self-scheduled TSR ○ SIBR shall consume self-scheduled TSR 		
EDAM-BRQ-15200	<p>EDAM/WEIM Entity needs to include the CRN when submitting the final tag information as part of the After The Fact tag through RTSI</p> <ul style="list-style-type: none"> • External Entity (EDAM and WEIM) to submit a schedule breakdown by CRN when submitting after the fact tag through RTSI – specifically to identify how the TSR schedules are divided <p>Note: The EDAM entity can submit the AFT tag for transmission right owner resource DA RSE with CRN</p>	Business Process	RTSI
EDAM-BRQ-15220	<p>Allow EDAM Entity to submit HASP Reversal Data</p> <ul style="list-style-type: none"> • Allow EDAM Entities to submit untagged MW of DA awards after HASP publication 	Core	RTSI

 California ISO	Technology	Template Version:	6.8
		Document Version:	6.1.7 1.7
Extended Day Ahead Market Business Requirements Specification - Planning		Date Created:	1/21/2026

5.11 Business Process: Manage RTM (RT-RSE, RTM)

- Calculate FRU/FRD requirements for the EDAM pool
- Run the WEIM RSE for EDAM up/down pools with the pool FRU/FRD requirements
- EDAM BAAs in the RSE passed pool shall be included in the WEIM RSE passed group
- EDAM pool in WEIM RSE shall fail as a pool
- AET optionality for failed EDAM up pool: form sub-pools of AET and of non-AET for the relevant intervals
- Do not allow the simultaneous relaxation of the PBC constraint and a net export transfer
- Equal priority for load and EDAM energy TSR
- Post-HASP curtailment rule to incorporate DA-TSR as same priority as load
- LMP Marginal energy cost component for each BAA

5.11.1 Business Requirements

ID#	Business Feature	Requirement Type	Potential Application(s) Impacted
EDAM-BRQ-16010	Market (STUC, RTPD, and RTD) need to account for any RTSI information coming past the HASP hour <ul style="list-style-type: none"> • Receive tag information as submitted by WEIM/EDAM entity via RTSI (refer to BRQ-15200) 	Existing	RTM
EDAM-BRQ-16015	Perform only WEIM base schedule Flex test for EDAM BAAs: <ul style="list-style-type: none"> • No Balance test in WEIM for EDAM BAA • No feasibility test • No capacity test • Only Flex test applies to EDAM BAA 	Core	RTBS
EDAM-BRQ-16017	For WEIM BAAs, Use Base Schedules when performing the balancing test <ul style="list-style-type: none"> • The system shall use the base schedules received from BSAP when performing the balancing test for WEIM BAAs 	Core Existing	RTBS
EDAM-BRQ-16018	Import/Export Schedule changes that occur after DA in RTSI shall be reflected in the corresponding WEIM MSRs <ul style="list-style-type: none"> • Any DA Import/Export schedule changes in RTSI shall be automatically reflected as base schedule 	Core	RTBS RTM

 California ISO	Technology	Template Version:	6.8
		Document Version:	6.1.7
Extended Day Ahead Market Business Requirements Specification - Planning		Date Created:	1/21/2026

ID#	Business Feature	Requirement Type	Potential Application(s) Impacted
	changes to the respective MSRs for performing the transmission feasibility, capacity, and flexible ramp sufficiency tests <ul style="list-style-type: none"> If a zero import/export self-schedule from an Intertie Transaction in RTM at an EDAM intertie from/to an EIM BAA to/from an EDAM BAA, except the CISO BAA, is adjusted in RTSI, the schedule change shall be automatically reflected at the corresponding Mirror System Resource at the respective intertie in that EIM BAA. 		
EDAM-BRQ-16020	Consume the EDAM up/down pool composition and forecast parameters for the FRUR/FRDR <ul style="list-style-type: none"> RTBS consumes from RTSI/SIBR EDAM pool composition to indicate EDAM BAAs that in EDAM upward/downward pools RTBS consumes the polynomial forecast parameters for calculation of FRUR/FRDR for the EDAM upward /downward pools 	Core	RTBS
EDAM-BRQ-16022	Calculate the interval FRUR/FRDR for the EDAM up/down pools at T-75, 55 and 40. <ul style="list-style-type: none"> Merge the EDAM upward pool corresponding BAAs' forecast for demand, solar, and wind Merge the EDAM downward pool corresponding BAAs' forecast for demand, solar, and wind Consume the estimated parameters for EDAM upward pool and EDAM downward pool Calculate the requirements FRUR /FRDR for the interval of the trading hours for EDAM upward/downward pools using merged forecasts of corresponding BAAs and the estimated parameters from the mosaic uncertainty polynomial Applies same threshold in the same manner as for WEIM RSE passing group 	Core	RTBS
EDAM-BRQ-16030	WEIM RSE Flex test for EDAM up/down pool with the pool FRU/FRD requirements <ul style="list-style-type: none"> For EDAM pool, run Flex test only, no Balance, feasibility, capacity test* 	Core	RTBS

 California ISO	Technology	Template Version:	6.8
		Document Version:	4.6 1.7
Extended Day Ahead Market Business Requirements Specification - Planning		Date Created:	1/21/2026

ID#	Business Feature	Requirement Type	Potential Application(s) Impacted
	<ul style="list-style-type: none"> • The WEIM-RSE shall run flex test, test the EDAM upward pool for FRU sufficiency, and EDAM downward pool for FRD sufficiency <ul style="list-style-type: none"> ○ WEIM RSE will use the latest available tag for imports, exports, and transfers <ul style="list-style-type: none"> ○ If no tag is submitted, schedules shall be set to 0 for the relevant (i.e., not tagged) testing hour(s) in the WEIM RSE Test ○ The EDAM TSR energy schedules are treated as base ETSR in WEIM RSE <p>*Note: Passing the Flex test implies the ability to pass the capacity test</p>		
EDAM-BRQ-16032	<p>WEIM RSE flex test for EDAM BAA that drop-out of EDAM pool</p> <ul style="list-style-type: none"> • For EDAM BAA that are not in the EDAM up pool, run flex up test for FRU sufficiency test • For import/export with non-EDAM and energy transfer with other EDAM BAAs based on the tag/transmission profile <p>Note: EDAM downward pool includes all the EDAM BAAs, since there is no checking the export tag status for EDAM BAA.</p>	Core	RTBS
EDAM-BRQ-16050	<p>If the EDAM pool passes the WEIM RSE, the EDAM pool will be added to WEIM RSE BAA pass group</p> <ul style="list-style-type: none"> • If EDAM up/down pool passes the +WEIM-RSE, report pass outcome for the EDAM pool in the same manner as for a WEIM BAA passing • For the BAA in pass group, calculate the FRUR/FRDR and procure the FRU/FRP in RTM 	Core	RTBS
EDAM-BRQ-16055	<p>The system shall calculate the FRU/FRP demand curve for each WEIM BAA</p> <ul style="list-style-type: none"> • The demand price curve for FRU/FRD is for individual BAA • The FRU/FRD surplus in each FRP Surplus Zone in each BAA in the WEIM Area is distributed in the ACPF solution with the same distribution factors that are used 	Existing	Internal ISO System

 California ISO	Technology	Template Version:	6.8
		Document Version:	4.6 1.7
Extended Day Ahead Market Business Requirements Specification - Planning		Date Created:	1/21/2026

ID#	Business Feature	Requirement Type	Potential Application(s) Impacted
	to distribute the FRU/FRD requirement, but renormalized for that FRP Surplus Zone that apply to EDAM pool		
EDAM-BRQ-16058	<p>EDAM BAA shall not submit Base Schedules</p> <ul style="list-style-type: none"> System shall not allow EDAM BAA to submit base schedules <p>Note: EDAM BAAs have DA schedule that will be used as reference for RT deviation settlement</p>	Core	BSAP
EDAM-BRQ-16060	<p>For EDAM up pool that failed WEIM RSE as a pool, divide it into AET sub-pool and non-AET sub-pool for each 15 minute interval</p> <ul style="list-style-type: none"> If EDAM up/down pool fails the WEIM-RSE, report the failure for the entire EDAM up/down pool Depending on the election of each BAA in the EDAM up pool to receive Assistance Energy Transfer (AET) or not (registered in MF), the EDAM up pool that failed RSE shall be divided into two sub-pools: the sub pool that will receive AET (the AET sub-pool) and the sub pool that will not receive AET (the non-AET sub-pool) <ul style="list-style-type: none"> The system shall broadcast the BAA composition of the AET sub-pool upward, and the non-AET sub-pool upward for each 15-minute interval 	Core	RTBS, RTM
EDAM-BRQ-16062	<p>Allow assistant energy transfer for AET Sub-pool in RTM</p> <ul style="list-style-type: none"> The system shall procure FRU in the RTM for each sub-pool up similar to a BAA that has failed the RSE upward test The AET sub-pool will be treated in RTPD, RTD, and STUC similar to a BAA that has elected to receive AET, i.e., without net transfer constraint at the sub-pool level and ex-post surcharge for those receiving AET (refer to RSEE Phase 2 BRS for details) The non-AET sub-pool will be treated in RTPD, RTD, and STUC similar to a BAA that has elected not to receive AET, i.e., with a net transfer 	Core	RTM

 California ISO	Technology	Template Version:	6.8
		Document Version:	6.1.7 1.7
Extended Day Ahead Market Business Requirements Specification - Planning		Date Created:	1/21/2026

ID#	Business Feature	Requirement Type	Potential Application(s) Impacted
	constraint at the sub-pool level and (refer to RSEE Phase 2 BRS for details)		
EDAM-BRQ-16065	<p>WEIM RSE for AET sub-pool after T-40</p> <ul style="list-style-type: none"> The system shall perform additional flex ramp up sufficiency test for the EDAM up AET sub-pool right after T-40 RSE test Use existing flex test for AET sub-pool System shall broadcast the insufficiency amount for AET sub-pool in 15-minute intervals If AET sub-pool fail the RT RSE, report the deficiency amount If AET sub-pool pass the RT RSE, report the surplus amount <p>Note: see Appendix A9 Business Flow Diagrams (a) The insufficiency amount will be used in Settlements for the AET surcharge. The AET sub-pool with surplus RSE will not be subject to AET surcharge.</p>	Core	RTBS
EDAM-BRQ-16088	<p>Include Mirror resource for the EDAM DA schedule for energy in the WEIM BAA's PBC</p>	Existing	RTPD, RTD
EDAM-BRQ-16090	<p>Do not allow the simultaneous relaxation of the PBC constraint and a net export transfer</p> <p>Model as the slack variable of PBC balance (positive as short of supply) cannot be the same direction as net transfer above IFM energy transfer (Appendix A3)</p> <p>For a given time interval, the BAA power balance constraint with penalized supply shortfall and surplus is as follows:</p> $\sum_{i \in BAA_j} G_{i,t} - D_{j,t} - T_{j,t} + s_{j,t}^{(+)} - s_{j,t}^{(-)} = 0$ <p>The power balance constraint relaxation when either the shortfall or the surplus take value is constrained as follows:</p> $\left(s_{j,t}^{(+)} + \sum_{i \in BAA_j} ABC_{i,t}^{(+)} \right) (T_{j,t} - \bar{T}_{j,t}^{(+)}) \leq 0$	Existing	RTPD, RTD

 California ISO	Technology	Template Version:	6.8
		Document Version:	4.61.7
Extended Day Ahead Market Business Requirements Specification - Planning		Date Created:	1/21/2026

ID#	Business Feature	Requirement Type	Potential Application(s) Impacted
	$\left(s_{j,t}^{(-)} + \sum_{i \in BAA_j} ABC_{i,t}^{(-)} \right) (T_{j,t} - \bar{T}_{j,t}^{(-)}) \geq 0$		
EDAM-BRQ-16100	Equal priority for demand and DAM TSR <ul style="list-style-type: none"> • In RTM penalty setting, equal priority for load and DAM energy TSR (same as base TSR) for BAA <ul style="list-style-type: none"> ○ In stressed system conditions, infeasibility by relaxing the power balance constraint in the BAA with insufficient supply. Same penalty cost for DAM energy transfer and base transfer and load for the BAA ○ The TSR Type 1s with CRN Self-Schedule (SS) late self-schedule have equal priority to the cleared DAM TSR with CRN self-schedule. ○ If OATT priority higher than RT SS is communicated (i.e., OATT 1), it shall be given ELC equivalent priority (no hedging) 	Core	RTPD, RTD
EDAM-BRQ-16102	Post-HASP curtailment rule to incorporate DA-TSR to have same priority as DAM schedule for ISO <ul style="list-style-type: none"> • Update post HASP curtailment rule. Include DA-TSR schedule, in addition to RA import, DAM import, PT wheel (PT export leg/Import leg), and PT export for ISO. <u>DA-TSR schedule will have equal priority as DAM cleared schedule in post-HASP curtailment.</u> • <u>DA TSRs type 1 and type 3 shall be treated the same as RA capacity. All DA TSRs will be part of HASP pro-rata curtailment taking into account their self-schedule priority. General rule for individual import schedules remains the same: Self-schedule priority, followed by bids in economic order. Mirrors of the curtailed DA TSRs shall be curtailed as well, balanced</u> 	Core	RTPD
EDAM-BRQ-16104	HASP Hourly block schedule revert to RUC schedule under HASP failure <ul style="list-style-type: none"> • In case of HASP failure, or operator manually blocking of HASP results, will revert to RUC 	Core	RTPD

 California ISO	Technology	Template Version:	6.8
		Document Version:	6.1.7
Extended Day Ahead Market Business Requirements Specification - Planning		Date Created:	1/21/2026

ID#	Business Feature	Requirement Type	Potential Application(s) Impacted
	schedule (IFM EN+RCU-RCD) for hourly import, IFM_EN-RCU+RCD for hourly export		
EDAM-BRQ-16110	LMP Marginal energy cost component for each BAA <ul style="list-style-type: none"> The LMP energy component (MEC) shall be the shadow price of each BAA PBC (a change from today WEIM), apply to DAM and RTM 	Core	RTPD,RTD
EDAM-BRQ-16112a	MPM for Energy at the WEIM BAA level–Trigger DCPA for PBC in RTPD Trigger for RTPD binding interval DCPA After RTPD MPM run for the RTPD all intervals compare the 15 minute interval t Marginal Energy Cost (MEC) of each WEIM BAA and CAISO BAA MEC <ul style="list-style-type: none"> If (WEIM BAA MEC > CAISO BAA MEC), the WEIM BAA is subject to PBC DCPA test for the interval t. otherwise, no DCPA test for the interval. 	Core	RTPD
EDAM-BRQ-16112b	MPM for Energy at the BAA level– DCPA for WEIM BAA PBC <ul style="list-style-type: none"> For each interval, for the WEIM BAAs triggered for DCPA, evaluate if BAA PBC is an uncompetitive constraint, treat PBC as a binding constraint, use same DCPA calculation as for other binding constraints Calculate RSI of PBC If RSI <1, the WEIM BAA PBC deemed as uncompetitive constraint on hourly basis. Otherwise, the BAA PBC deemed competitive 	Core	RTPD
EDAM-BRQ-16112c	Apply MPM for Energy at the BAA level-LMPM for WEIM resources; Calculate competitive LMP that excludes differential of MECs Calculate competitive LMP: <ul style="list-style-type: none"> For the WEIM BAAs have interval uncompetitive PBC, exclude uncompetitive MCC, exclude the differential between WEIM BAA MEC and CAISO MEC from nodal LMP for competitive LMP calculation for all price nodes in the BAA that apply LMPM in 15 minute interval. For the WEIM BAAs with competitive PBC, exclude uncompetitive MCC from nodal LMP for competitive 	Core	RTPD

 California ISO	Technology	Template Version:	6.8
		Document Version:	6.1.7
Extended Day Ahead Market Business Requirements Specification - Planning		Date Created:	1/21/2026

ID#	Business Feature	Requirement Type	Potential Application(s) Impacted
	<p>LMP as currently for all price nodes in the EDAM BAA.</p> <ul style="list-style-type: none"> Bid mitigation: If uncompetitive portion $LMP_i^{NC} > \text{Mitigation Threshold Price}$, the resource bid would be mitigated to the higher of the default energy bid (DEB) and its competitive LMP. The bid mitigation apply to all the resources that subject to LMPM. Only mitigate resources that have net positive contribution to the LMP <ul style="list-style-type: none"> Apply exiting RTPD MPM rule, mitigated bid curve on RTPD intervals 		
EDAM-BRQ-16112d	<p>MPM for Energy at the WEIM BAA level—for PBC in RTD</p> <ul style="list-style-type: none"> Trigger for RTD DCPA: After each RTD run, if the first three advisory intervals Marginal Energy Cost (MEC) of each WEIM BAA > CAISO BAA MEC RTD DCPA the three advisory interval: use Ramp capacity for 5 minute DCF for energy and FRU/FRD deployment scenario. Same calculation for uncompetitive paths as $RSI_{m,t} < 1$ Note: in SCF we include all AS awards from FMM, and use 5 min ramp capability Calculate Competitive $LMP_{i,t}$ that exclude uncompetitive MCC and exclude differential between of WEIM BAA MEC and ISO MEC from LMP for uncompetitive PBC Mitigate the resource energy bid to the higher of the DEB and its competitive $LMP_{i,t}$ <ul style="list-style-type: none"> Apply existing RTD MPM rule, first three advisory intervals inherent from previous RTD on rolling forward basis, the other RTD intervals use unmitigated bids. <p>MPM Timing and intervals for FMM and RTD:</p>	Core	RTD

 California ISO	Technology	Template Version:	6.8
		Document Version:	4.61.7
Extended Day Ahead Market Business Requirements Specification - Planning		Date Created:	1/21/2026

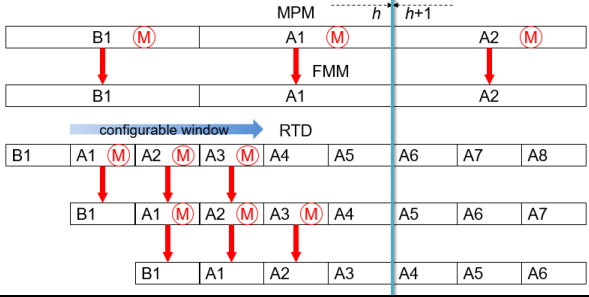
ID#	Business Feature	Requirement Type	Potential Application(s) Impacted
			
EDAM-BRQ-16130	<p>Extend BAA FRP Procurement to the sub-pool for the 15-minute interval that is binding for energy scheduling in FMM</p> <ul style="list-style-type: none"> FRU procurement constraint formed for AET sub-pool without restraining the transfer FRU procurement constraint formed for non-AET sub-pool with restraining the transfer 	Core RSEE2	RTPD STUC
EDAM-BRQ-16140	<p>The WEIM ABC functionality shall NOT apply to EDAM BAA</p> <ul style="list-style-type: none"> For the EDAM BAA, all the regulation self-provision, in DAM and RTM shall NOT be eligible for ABC in RTM. Regulation self-provision shall not be treated as ABC 	Core	RTPD, RTD
EDAM-BRQ-16145	<p>Extend to EDAM: Calculate and broadcast SP-Tie FRU/FRD Marginal Price (FRUMP/FRDMP) in RTM for Nodal by Direction (Import/Export)</p> <p>For import direction FRU</p> <ul style="list-style-type: none"> SP nodal price of FRU (plus) the shadow prices of import directions for Inter-Tie Scheduling Limits (ISLs) or Inter-Tie Constraint (ITCs) associated with that SP-Tie location of FRU <p>For export direction FRU</p> <ul style="list-style-type: none"> SP nodal price of FRU 	Core	RTM

 California ISO	Technology	Template Version:	6.8
		Document Version:	6.1.7 1.7
Extended Day Ahead Market Business Requirements Specification - Planning		Date Created:	1/21/2026

ID#	Business Feature	Requirement Type	Potential Application(s) Impacted
	<ul style="list-style-type: none"> (minus) the shadow prices of export directions for Inter-Tie Scheduling Limits (ISLs) or Inter-Tie Constraint (ITCs) associated with that SP-Tie location of FRU <p>For import direction FRD</p> <ul style="list-style-type: none"> SP nodal price of FRD (minus) the shadow prices of export directions for Inter-Tie Scheduling Limits (ISLs) or Inter-Tie Constraint (ITCs) associated with that SP-Tie location of FRD <p>For export direction FRD</p> <ul style="list-style-type: none"> SP nodal price of FRD (plus) the shadow prices of import directions for Inter-Tie Scheduling Limits (ISLs) or Inter-Tie Constraint (ITCs) associated with that SP-Tie location of FRU <p>Note Refer to DAME-BRQ-06100</p>		
EDAM-BRQ-16150	<p>Extend to EDAM: Include ITC/ISL Shadow Prices from SP-Tie FRU/FRD Marginal Price (FRUMP/FRDMP) in RTM for Resource</p> <ul style="list-style-type: none"> SP nodal price of FRU <p>Note Refer to DAME-BRQ-06120</p>	Existing	RTM
EDAM-BRQ-HASP-16187	<p>Introduce a new flag HASP_YN to indicate whether a resource participates in HASP</p> <ul style="list-style-type: none"> Define how the market optimization engine should treat resources based on combinations of DAM_YN, HASP_YN, and RTM_YN <ul style="list-style-type: none"> These flags are editable by CAISO only, and will be not included in resource data template (RDT) <p>For different resource types, apply rules set by CISO in the table:</p>	Core	MF



ID#	Business Feature					Requirement Type	Potential Application(s) Impacted
	Resource TYPE	DAM_YN	HASP_YN (4 intervals of the HASP hour)	RTM_YN	Market Behavior		
	CISO internal Resource (including PDR/RDRR)	Y	Y	Y	Participate in DAM/STUC/RTPDRTD, Market optimize the resource , while respecting the bid dispatch option		
	EDAM Resource	Y	Y	Y	Participate in DAM/STUC/RTPDRTD, Market optimize the resource , while respecting the bid dispatch option		
	SR at GGAP	Y	N	N	Participate in DAM only. In RTM, Market follow its self schedule or tag Note: not active in transitional period		
	SR/TG/IT at EIM BAA GAP	Y	Y	N	Participate in DAM/HASP, Market optimize the resource; in other runs, the resource stay at its most recent tag or self schedule or HASP schedule or tag		
	SR/TG/IT at non-EIM BAA GAP	Y	Y	Y	Participate in DAM/STUC/RTPDRTD, Market optimize the resource , while respecting the bid dispatch option; start populating this flag		
	TYPE1 TSR	Y	Y	N	Resource stay at its most recent self schedule or HASP schedule or tag		
	TYPE 2, 3 and 4 TSRs between EDAM and EDAM BAAs	Y	N	N	Participate in DAM only. In RTM, Market follow its self schedule or tag		



ID#	Business Feature					Requirement Type	Potential Application(s) Impacted
	Dynamic/static ETSRs between EDAM and EDAM BAAs	N	Y	Y	Participate in STUC/RTPD/RTD. Market optimize in all RTM runs.		
	Dynamic/static ETSRs between EIM only and EDAM BAAs	N	YN	Y	Participate in STUC/RTPD/RTD. Market optimize in all RTM runs. DO NOT participate in DAM/HASP. Market optimize in non-HASP intervals in RTM.		
	Dynamic/static ETSRs between EIM only and EIM only BAAs	N	Y	Y	Participate in STUC/RTPD/RTD. Market optimize in all RTM runs.		
	EIM Non-Participating Resource/base ETSR	N	N	N	Resource do NOT participate in DAM/STUC/RTPD/RTD. Market does not optimize the resource, use base schedule		
	EIM Participating Resource	N	Y	Y	Participate in STUC/RTPD/RTD. Market optimize in all RTM runs.		
	Load resource	Y	N	N	Participate in DAM only. In RTM, Market use forecast		
EDAM-BRQ-HASP-16189	SIBR must allow RTM bids at T-75 if either HASP_YN or RTM_YN is set to Y <ul style="list-style-type: none"> For any type of resources with HASP_YN or RTM_YN is set to Y, allow these resources to submit self-schedules or economic bids in RTM 					Core	SIBR
EDAM-BRQ-HASP-16190	Optimize resources based on combinations of resource, DAM_YN, HASP_YN, and RTM_YN flags <ul style="list-style-type: none"> If DAM_YN = Y: Resource is eligible for DAM optimization. If DAM_YN = N: Resource is not eligible for DAM optimization. 					Core	DAM, RTM

 California ISO	Technology	Template Version:	6.8
		Document Version:	4.61.7
Extended Day Ahead Market Business Requirements Specification - Planning		Date Created:	1/21/2026

ID#	Business Feature	Requirement Type	Potential Application(s) Impacted															
	<ul style="list-style-type: none"> If HASP_YN = Y: Resource is eligible for HASP optimization (4 intervals of the HASP hour). If HASP_YN = Y and RTM_YN = Y: Market optimizes the resource in STUC, RTPD, and RTD If HASP_YN = Y and RTM_YN = N: Optimize in HASP only, Resource retains most recent HASP schedule, DAM award, base schedule or self-schedule/tag If HASP_YN = N and RTM_YN = Y: optimize non-HASP intervals only in STUC, RTPD, RTD If HASP_YN = N and RTM_YN = N: No optimization in STUC, RTPD, RTD, follow the base schedule, self-schedule or tag Under all the Flags options, Respect bid dispatch options where applicable. 																	
EDAM-BRQ-HASP-16190a	<p>Populate DAM_YN, HASP_YN, and RTM_YN flags for market generated transient resources IT, TSR, ETSR, according to the rule of resource type</p> <ul style="list-style-type: none"> For the intertie resource that does not register in MF, include the intertie transaction ID (IT), EDAM transfer (TSR), WEIM transfer (ETSR) generated in the market, populate the DAM_YN, HASP_YN, and RTM_YN flags according to the following rule based on the resource type: <table border="1" style="width: 100%; border-collapse: collapse;"> <thead> <tr> <th style="text-align: center;">Resource TYPE</th> <th style="text-align: center;">DAM_YN</th> <th style="text-align: center;">HASP_YN (4 intervals of the HASP hour)</th> <th style="text-align: center;">RTM_YN</th> <th style="text-align: center;">Market Behavior</th> </tr> </thead> <tbody> <tr> <td style="text-align: center;">SR/TG/IT at EIM BAA GAP</td> <td style="text-align: center;">Y</td> <td style="text-align: center;">Y</td> <td style="text-align: center;">N</td> <td>Participate in DAM/HASP, Market optimize the resource; in other runs, the resource stay at its most recent tag or self schedule or HASP schedule or tag</td> </tr> <tr> <td style="text-align: center;">SR/TG/IT at non-EIM BAA GAP</td> <td style="text-align: center;">Y</td> <td style="text-align: center;">Y</td> <td style="text-align: center;">Y</td> <td>Participate in DAM/STUC/RTPD/RTD, Market optimize the resource, while respecting the bid dispatch option; start populating this flag</td> </tr> </tbody> </table>	Resource TYPE	DAM_YN	HASP_YN (4 intervals of the HASP hour)	RTM_YN	Market Behavior	SR/TG/IT at EIM BAA GAP	Y	Y	N	Participate in DAM/HASP, Market optimize the resource; in other runs, the resource stay at its most recent tag or self schedule or HASP schedule or tag	SR/TG/IT at non-EIM BAA GAP	Y	Y	Y	Participate in DAM/STUC/RTPD/RTD, Market optimize the resource, while respecting the bid dispatch option; start populating this flag	Core	DAM, RTM
Resource TYPE	DAM_YN	HASP_YN (4 intervals of the HASP hour)	RTM_YN	Market Behavior														
SR/TG/IT at EIM BAA GAP	Y	Y	N	Participate in DAM/HASP, Market optimize the resource; in other runs, the resource stay at its most recent tag or self schedule or HASP schedule or tag														
SR/TG/IT at non-EIM BAA GAP	Y	Y	Y	Participate in DAM/STUC/RTPD/RTD, Market optimize the resource, while respecting the bid dispatch option; start populating this flag														

 California ISO	Technology	Template Version:	6.8
		Document Version:	6.1.7
Extended Day Ahead Market Business Requirements Specification - Planning		Date Created:	1/21/2026

ID#	Business Feature					Requirement Type	Potential Application(s) Impacted
	TYPE1 TSR	Y	Y	N	Resource stay at its most recent self schedule or HASP schedule or tag		
	TYPE 2 TSRs EDAM and EDAM BAAs	Y	N	N	Participate in DAM only. In RTM, Market follow its self schedule or tag		
EDAM- BRQ- 16195	Provide Visibility of DA TSRs in BAAOP					Core	BAAOP
EDAM- BRQ- 16200	RTM shall calculate MSR Price based on SP <ul style="list-style-type: none"> System shall calculate the price for MSR based on the resource scheduling point location instead of the SP-TIE. 					Core	RTM

 California ISO	Technology	Template Version:	6.8
		Document Version:	6.1.7 1.7
Extended Day Ahead Market Business Requirements Specification - Planning		Date Created:	1/21/2026

5.12 Business Process: Manage GHG in DAM & RTM (GHG pass, GHG model in DAM and RTM)

- Build GHG reference pass in DAM
- Use full optimization without net imports to GHG area for GHG reference pass
- In GHG reference pass: no reference for GHG contractual resource outside the GHG regulation areas
- Store resource energy schedules as GHG reference point
- In the DAM: model resource specific GHG model for multiple GHG regulation areas using resource reference point from GHG pass
- Include GHG transfer attribution constraint in MPM and IFM for each GHG regulation area and outside resource above GHG reference point
- Calculate GHG constraint shadow price
- The aggregate GHG attribution to resources in a BAA in a non-GHG area is limited by the hourly/interval net export constraint in DAM and RTM
- WEIM RTM GHG model changes

5.12.1 Business Requirements

ID#	Business Feature	Requirement Type	Potential Application(s) Impacted
EDAM-BRQ-17020	Build GHG reference pass in DAM <ul style="list-style-type: none"> • Build a different pass that can run with same market inputs • GHG reference pass can be run by user manually, or: • Timed automatic run after DAM close at 10 am, before MPM • If the GHG reference pass fails, resource reference will be 0 • For NPM no GHG reference pass 	Core	DAM GHG Pass
EDAM-BRQ-17030	Use full optimization without net import to GHG regulation area(s) for GHG reference Pass Run GHG reference pass with full optimization identical to IFM, except: <ul style="list-style-type: none"> • Ignore GHG bids, i.e., do not consider GHG bids when determining optimal energy schedules, and with no impact of the GHG net export constraint 	Core	DAM GHG Pass

 California ISO	Technology	Template Version:	6.8
		Document Version:	6.1.7
Extended Day Ahead Market Business Requirements Specification - Planning		Date Created:	1/21/2026

ID#	Business Feature	Requirement Type	Potential Application(s) Impacted
	<ul style="list-style-type: none"> The GHG transfer of each GHG regulation area [supply (include CB, Gen bid, GHG pseudo-tie) Import from non-EDAM minus export, minus load minus loss] is constrained above or equal zero, i.e., no net import into a GHG regulation area is allowed, but allow net export from GHG regulation area 		
EDAM-BRQ-17040	<p>In the GHG reference pass, no GHG reference for contractual resource capacity registered in MF as committed to serve demand in a GHG regulation area</p> <ul style="list-style-type: none"> Access MF defined contractual resources located outside of a GHG regulation area Receive SIBR submitted hourly contractual resource capacity Use SIBR submitted hourly contractual resource capacity, if not submitted fall back to MF default value The energy bids of contractual capacity resources are ignored for reference calculation purposes. Resource capacity with contractual obligation to serve the demand in a GHG regulation area shall not receive a GHG reference schedule The resource capacity that exceeds the contractual obligation shall be in the GHG pass <p>Ex: Resource Pmax= 200 MW, GHG contract for 120 MW (defined in MF), so 80 MW need to be in GHG pass</p> <p>Note: This BRQ applies only to resources that are not GHG pseudo-tied.</p>	Core	DAM GHG Pass
EDAM-BRQ-17050	<p>The GHG reference pass shall ensure that there are valid reference schedules</p> <ul style="list-style-type: none"> Ensure the GHG reference point is the max of: 0, positive dispatch 	Core	DAM GHG Pass
EDAM-BRQ-17060	<p>Store resource energy schedule from GHG reference pass as the GHG reference point for MPM and IFM</p> <ul style="list-style-type: none"> Store the GHG pass resource scheduled MW to support GHG reference point in MPM, IFM 	Core	DAM GHG Pass (CMRI)

 California ISO	Technology	Template Version:	6.8
		Document Version:	6.1.7
Extended Day Ahead Market Business Requirements Specification - Planning		Date Created:	1/21/2026

ID#	Business Feature	Requirement Type	Potential Application(s) Impacted
	Note: Report SC/entity on CMRI		
EDAM-BRQ-17070	<p>The DAM will use the resource-specific GHG model for multiple GHG regulation areas using the resource's GHG reference point from the GHG reference pass: Access data</p> <ul style="list-style-type: none"> • In MPM and IFM, use the resource specific attribution GHG model, similar to the model used in the WEIM • Access the MF-defined GHG regulation areas and associated resources • Consume the SIBR-submitted GHG bids and the association of a resource's GHG bid to a specific GHG regulation area <p>Note: Allow resource in one GHG area to submit bids for other GHG regulation areas</p>	Core	DAM
EDAM-BRQ-17070a	<p>GHG Model: The DAM will use the resource-specific GHG model for multiple GHG regulation areas using the resource's GHG reference point from GHG pass</p> <ul style="list-style-type: none"> • Optimal allocation GHG transfer to non-GHG regulation area resource for each GHG area <ul style="list-style-type: none"> ◦ Include the GHG bids for the portion of the GHG MW allocated to the resource in the objective function • The GHG transfer for each GHG regulation area is defined as (physical and virtual supply (include PDR and Gen bid, GHG pseudo-tie) minus physical and virtual load schedule and export minus loss in IFM) for the GHG area • Transmission losses in the GHG regulation area are derived from the ACPF solution, but their marginal impact on the constraint is ignored • If losses are not calculated by the ACPF solution, use a static percentage of the BAA's losses that are being attributed to a particular GHG region. • The GHG import allocation constraint is modeled as import GHG transfer less than sum of GHG attributions for each GHG area 	Core	DAM

 California ISO	Technology	Template Version:	6.8
		Document Version:	4.6 1.7
Extended Day Ahead Market Business Requirements Specification - Planning		Date Created:	1/21/2026

ID#	Business Feature	Requirement Type	Potential Application(s) Impacted
EDAM-BRQ-17080	<p>Include GHG transfer attribution constraint in MPM and IFM for each GHG regulation area and outside resource above GHG reference point</p> <ul style="list-style-type: none"> • For each resource with GHG bids, the attribution amount is limited by the min of the GHG bid, optimal energy, and the value of the positive difference between the available capacity UEL and GHG reference point that is calculated through the GHG pass. Ensure the GHG reference point is the max of (0, (NGR) positive dispatch), applicable for resource with negative Pmin • GHG attribution constraint allocates GHG transfer of the GHG regulation area to EDAM resources outside of this GHG regulation area with GHG bids <ul style="list-style-type: none"> ○ Allow resources in GHG regulation area with GHG bid adders to serve other GHG regulation areas ○ For resources located outside of a GHG regulation area that do not have a GHG bid adder, or have a bid adder of 0 MW to serve Demand within a specific GHG Regulation Area, do not attribute the resource as supporting a GHG Transfer into that specific GHG Regulation Area 	Core	MPM, IFM
EDAM-BRQ-17090	<p>Calculate DA GHG marginal price</p> <ul style="list-style-type: none"> • Calculate shadow price of GHG import allocation constraint for each GHG regulation area as GHG marginal price to serve this GHG regulation area from outside resources. This will be used for GHG Settlements 	Core	DAM
EDAM-BRQ-17100	<p>Calculate GHG MGC component in LMP for EDAM footprint</p> <ul style="list-style-type: none"> • With GHG transfer attribution constraint modeled as import, calculate through supply minus demand for GHG regulation area. The MGC will be a positive value at the node of GHG 	Core	DAM

 California ISO	Technology	Template Version:	6.8
		Document Version:	6.1.7
Extended Day Ahead Market Business Requirements Specification - Planning		Date Created:	1/21/2026

ID#	Business Feature	Requirement Type	Potential Application(s) Impacted
	regulation area. The MGC will be zero for the node outside of the GHG regulation area. <ul style="list-style-type: none"> • Calculate EDAM LMP GHG MGC components in DAM and RTM. • Competitive LMP calculation should include MGC as well 		
EDAM-BRQ-17110	Deactivate Gross GHG attribution constraints (GHG net export constraint) if BAA failed RSE <ul style="list-style-type: none"> • Hourly activate flag for Gross GHG attribution constraints (GHG net export constraint) –system wide - one flag for DAM and one flag for RTM <ul style="list-style-type: none"> ○ If any BAA that overlaps with GHG regulation area failed EDAM RSE upward, the constraint will be automatically turned off for the failed hour for the system ○ In RTM, for the intervals failed RT RSE upward, the constraint is turned off 	Core	DAM, RTM
EDAM-BRQ-17120	Gross GHG attribution Constraints: The aggregate GHG attribution to resources in a BAA in the non-GHG regulation area is limited by the hourly GHG net export constraint For each BAA outside of a GHG regulation area: <ul style="list-style-type: none"> • Access MF flag for the BAA that overlap with a GHG regulation area. Only the BAA that do not overlap with a GHG regulation area can enforce the GHG net export constraint. • Add hourly constraints to limit aggregated GHG attribution to the resources in a BAA: <ul style="list-style-type: none"> • The aggregate GHG attribution to resources in a BAA is limited to the max () of following: <ul style="list-style-type: none"> ○ The total resource capacity in the EDAM BAA that is contractually obligated to serve demand in GHG regulation areas, ○ The gross RSE-eligible export transfers from the EDAM BAA to other EDAM BAAs that overlap with GHG regulation areas, or 	Core	MPM, IFM

 California ISO	Technology	Template Version:	6.8
		Document Version:	6.1.7
Extended Day Ahead Market Business Requirements Specification - Planning		Date Created:	1/21/2026

ID#	Business Feature	Requirement Type	Potential Application(s) Impacted
	<ul style="list-style-type: none"> ○ The net transfer (positive for export and negative for import) of the BAA at the optimal solution of the previous iteration excluding the base transfer. 		
EDAM-BRQ-17122	<p>GHG net export constraint for one GHG area resources that serve other GHG areas</p> <ul style="list-style-type: none"> 2 Add hourly constraints to limit aggregated GHG attribution to the resources in a GHG area that attribute to other GHG areas 3 Where is the first term in the max() function is the total resource capacity that is contractually obligated to serve demand in other GHG regulation areas and the second term is the GHG transfer of the GHG regulation area at the optimal solution of the previous iteration. 	Core	IFM
EDAM-BRQ-17130	<p>In RUC, No GHG is modeled</p> <ul style="list-style-type: none"> • No GHG bids in RUC • No GHG transfer constraint • No resource GHG capacity constraint 	Core	RUC
EDAM-BRQ-17200	<p>WEIM RTM GHG model changes:</p> <ul style="list-style-type: none"> • Same as for EDAM, change WEIM GHG implementation to use GHG transfer (supply, include GHG pseudo-tie minus demand in GHG regulation area) instead of BAA-BAA transfer to avoid defining the intra-BAA transfer between CLAPs that is separated by the GHG state boundary in the net export to a GHG regulation area <ul style="list-style-type: none"> ○ The GHG transfer of each GHG regulation area for the GHG area less than sum of GHG attribution. ○ RT will have different number of WEIMs vs number of EDAM entities, consequently different number of resources with GHG contract, bid, etc., consequently different reference and attribution for each resource. 	Core	RTM

 California ISO	Technology	Template Version:	6.8
		Document Version:	6.1.7
Extended Day Ahead Market Business Requirements Specification - Planning		Date Created:	1/21/2026

ID#	Business Feature	Requirement Type	Potential Application(s) Impacted
	<ul style="list-style-type: none"> • Distribute the load forecast BAA by LDF to the nodes that correspond to each GHG regulation area (state: WA, CA) boundary • For each resource with GHG bids, the deemed allocation amount is limited by min of the GHG bid, optimal energy, and the value of the positive difference between the available capacity UEL and the GHG reference point <ul style="list-style-type: none"> ○ Calculated through the IFM pass for EDAM BAA resource (max(0,IFM schedule-GHG attribution)) or ○ Base schedule for the resource in WEIM BAA only. Ensure the GHG reference point is the max of (0, NGR positive dispatch) 		
EDAM-BRQ-17210	<p>Gross GHG attribution constraints in WEIM:</p> <ul style="list-style-type: none"> • Add activation/deactivation flag for Gross GHG Attribution constraint for RTM <ul style="list-style-type: none"> ○ If any BAA that overlaps with a GHG regulation area has failed the WEIM RSE (capacity or flex test) in a fifteen minute interval, the constraint will be deactivated for the RTPD and RTD for that interval <p><u>For each BAA that does not overlap with any GHG regulation area:</u></p> <ul style="list-style-type: none"> • The sum of all GHG attributions from the resources for each 5 min/15 min interval in the BAA shall be limited to the higher of: <ul style="list-style-type: none"> ○ Total capacity that is contractually obligated to serve demand in GHG regulation areas, as specified in the resource registry in the MF ○ The net BAA transfer at the optimal solution of the previous iteration (the constraint will not be enforced in the first RTPD SCUC without network; in RTD, the previous iteration is the first advisory of the previous RTD run) • For EDAM BAAs: <ul style="list-style-type: none"> ○ Sum of DA export transfer to other EDAM BAAs that overlap with GHG regulation 	Core	RTM

 California ISO	Technology	Template Version:	6.8
		Document Version:	6.1.7 1.7
Extended Day Ahead Market Business Requirements Specification - Planning		Date Created:	1/21/2026

ID#	Business Feature	Requirement Type	Potential Application(s) Impacted
	<p>areas plus the sum of DA exports to EIM BAAs that overlap with GHG regulation areas</p> <ul style="list-style-type: none"> • For WEIM BAAs: <ul style="list-style-type: none"> ○ The sum of base export transfer to EIM BAAs that overlap with GHG regulation areas plus the sum of export Mirror System Resource base schedules that mirror DA imports to EDAM BAAs that overlap with GHG regulation areas <p>For each GHG regulation area for other GHG regulation areas</p> <ul style="list-style-type: none"> • The sum of all GHG attribution from resources for each 5min/15min interval in the GHG regulation area shall be limited to the higher of: <ul style="list-style-type: none"> ○ Total capacity that is contractually obligated to serve demand in other GHG regulation areas, as specified in the resource registry in the MF ○ The GHG transfer at the optimal solution of the previous iteration (the constraint will not be enforced in the first RTPD SCUC without network; in RTD, the previous iteration is the first advisory of the previous RTD run) 		
EDAM-BRQ-17230	<p>Calculate RT GHG marginal price</p> <ul style="list-style-type: none"> • Calculate shadow price of GHG import allocation constraint for each GHG regulation area as GHG marginal price to serve this GHG regulation area from outside resources. This will be used for GHG Settlements 	Core	RTM
EDAM-BRQ-17240	<p>Define CLAP for load in each GHG Regulation Area and load outside of all GHG Regulation Areas for both EDAM and WEIM BAA</p> <ul style="list-style-type: none"> • Define Load Resource ID for each CLAP <ul style="list-style-type: none"> ○ For WEIM: Load Resource ID shall only be associated with WEIM Entity 	Process	MF

 California ISO	Technology	Template Version:	6.8
		Document Version:	4.61.7
Extended Day Ahead Market Business Requirements Specification - Planning		Date Created:	1/21/2026

ID#	Business Feature	Requirement Type	Potential Application(s) Impacted
	<ul style="list-style-type: none"> For EDAM only: any SC registered load that partially overlaps with GHG regulation areas will need to be split into separate CLAPs 		
EDAM-BRQ-17241	For all WEIM and EDAM BAAs: Validate that CLAPs and ELAP fully overlap (i.e., all load is accounted for)	Core Existing	MF
EDAM-BRQ-17246	Extend to EDAM: Calculate LAP LDFs <ul style="list-style-type: none"> Calculate the LDFs for all LAPs at BAA forecast level for all EDAM BAAs Note: Functionality is existing for CAISO BAA and WEIM BAAs	Existing	DAM/RTM
EDAM-BRQ-17248	Differentiate between existing and new load base schedule calculations. <ul style="list-style-type: none"> Existing load base schedule calculations should not be impacted by this CLAP/LDF model 	Core	RTBS
EDAM-BRQ-17249	Calculate base load for WEIM BAA CLAPs using ELAP LDF data	Core	RTBS
EDAM-BRQ-17251	Consume and publish all WEIM/EDAM BAA LDFs to WEIM/EDAM Entities	Core	MPP
EDAM-BRQ-17255	WEIM/EDAM Entities shall provide load meter based on LAP Resource IDs <ul style="list-style-type: none"> Meter may be based on BA load meter and LDF. Meter = calculated load*LDF 	Participant Core	N/A

 California ISO	Technology	Template Version:	6.8
		Document Version:	6.1.7
Extended Day Ahead Market Business Requirements Specification - Planning		Date Created:	1/21/2026

5.13 Business Process: Manage Market Quality, Validation and Price Correction

- Extend to EDAM the DA schedule forecasted movement calculation
- Extend to EDAM: resources FMM ex-post capacity calculation
- Extend to EDAM: resources IRU/IRD, RCU/RCD FMM ex-post capacity allocation
- Extend to EDAM: resource Expected Energy calculations and allocation
- Exclude DAM TSR from expected energy calculations and allocations
- Extend to EDAM: resource Ex-Post Capacity calculations and allocation
- Extend to EDAM: resource Auxiliary Capacity calculations
- Extend to EDAM: RTM Resource Commitment Cost determination
- Extend to EDAM: resource IRU/IRD award 5-minute ramp capable portion calculation

5.13.1 Business Requirements

ID#	Business Feature	Requirement Type	Potential Application(s) Impacted
EDAM-BRQ-18140	Extend Calculation of DA schedule Forecasted movement to EDAM <ul style="list-style-type: none"> • Calculate nodal, by SC, the hourly DA Forecasted Movement as: For CAISO and EDAM BAA resources: <ul style="list-style-type: none"> ○ DA Schedule Forecasted Movement (h) = $DAES_{DAM,h} - DAES_{DAM,h-1}$ 	Existing DAME	Internal ISO System
EDAM-BRQ-18505	Extend to EDAM resources the Resource Expected Energy Calculations, Allocations <ul style="list-style-type: none"> • System shall extend to EDAM resources the Resource Expected Energy Calculations and Allocations 	Existing DAME	Internal ISO System
EDAM-BRQ-18510	Exclude DAM TSR, from expected energy calculations and allocations <ul style="list-style-type: none"> • System shall exclude DAM TSR, from expected energy calculations and allocations, similar to existing WEIM ETSRs. 	Core	Internal ISO System
EDAM-BRQ-18515	Extend to EDAM resources the Resource Ex-Post Capacity Calculation and Allocations	Existing DAME	Internal ISO System



ID#	Business Feature	Requirement Type	Potential Application(s) Impacted
	System shall extend to EDAM resources the Resource Ex-Post Capacity Calculations and Allocations		
EDAM-BRQ-18520	Extend to EDAM resources the resource FMM ex-post capacity calculation System shall extend to EDAM resources the resource FMM ex-post capacity calculation	Core DAME	Internal ISO System
EDAM-BRQ-18525	Extend to EDAM resources the resource IRU/IRD, RCU/RCD FMM ex-post capacity allocation System shall extend to EDAM resources the resource IRU/IRD, RCU/RCD FMM ex-post capacity allocation	Existing DAME	Internal ISO System
EDAM-BRQ-18530	Extend to EDAM resources the Resource Auxiliary Capacity Calculations System shall extend to EDAM resources the Resource Auxiliary Capacity Calculation	Core DAME	Internal ISO System
EDAM-BRQ-18535	Extend to EDAM resources the Resource RT Commitment Cost Determination System shall extend to EDAM resources the Resource RT Commitment Cost Determination	Existing DAME	Internal ISO System
EDAM-BRQ-18540	Extend to EDAM resources the Resource IRU/IRD award 5-minute ramp capable portion calculation System shall extend to EDAM resources the Resource IRU/IRD award 5-minute ramp capable portion calculation	Existing DAME	Internal ISO System
EDAM-BRQ-18545	Extend Calculations of 5-min Ramp-Capable Portion Data to EDAM resources System shall extend calculation of 5-min Ramp-Capable Portion Data to EDAM resources	Existing DAME	Internal ISO System
EDAM-BRQ-18547	Extend Use of IFM MSG Configuration as Reference for RT MLC Calculations to EDAM System shall extend use of IFM MSG configuration as reference for RT MLC calculations to EDAM.	Existing DAME	Internal ISO System

 California ISO	Technology	Template Version:	6.8
		Document Version:	4.6 1.7
Extended Day Ahead Market Business Requirements Specification - Planning		Date Created:	1/21/2026

ID#	Business Feature	Requirement Type	Potential Application(s) Impacted
EDAM-BRQ-18550	Extend Consuming market result and corrected market result for EDAM resource <ul style="list-style-type: none"> • System shall extend consumption of IFM produced resource awards and Ramp Rate Curve to EDAM BAAs • System shall extend consumption of corrected resource awards and ramp rate curve to EDAM BAAs 	Existing DAME	Internal ISO System

 California ISO	Technology	Template Version:	6.8
		Document Version:	6.1.7 1.7
Extended Day Ahead Market Business Requirements Specification - Planning		Date Created:	1/21/2026

5.14 Business Process: Manage Congestion Revenue Allocation

- Include S/DGAP-Tie schedule to corresponding ITC/ISL constraint
- Identify CRN schedules in EDAM area that are eligible for parallel flow adjustment
- Set IFM Total flow, IFM net flow, CRN net flow, IR flow
- Determine CRR prevailing flow direction based on IFM total flow
- Calculate congestion flow difference between the IFM net flow and the CRR net flow
- Calculate the proportion (%) of the CRR net flow to all aggregated CRRs net flow
- Calculate Offset MW for each CRR as proportion of CFD
- Calculate Offset revenue by constraint
- Calculate CRR hourly/daily Notional Revenue for binding constraints of all EDAM BAAs
- Calculate CRR Clawback revenue for the constraints of all EDAM BAAs
- Calculate CRR Circular Scheduling Revenue
- Report CRR Revenue Adjustments Details
- Report CRR Aggregated Revenue Adjustments Data IFM net flow
- Use CRR settlement logic with mapping to new attributes BAA and deployment scenario
- Include in CRR balancing Account the CRN parallel flow congestion revenue adjustment for CAISO BAA
- Calculate the hourly balanced CRN (OATT) self-schedules
- Calculate each BAA IFM Energy Congestion Revenue, ETC/TOR Congestion Credit, OATT Congestion Adjustment separately
- Manage OATT balanced self-schedule Congestion Adjustment, credit to EDAM entity schedule located, reversal to EDAM entity where congestion located
- Manage ETC/TOR balanced self-schedule Congestion Adjustment, credit to Billing SC, reversal to EDAM entity where congestion located
- Calculate the Day-ahead hourly Marginal Congestion Offset for each EDAM BAA include OATT adjustment
- For CAISO, OATT balanced self-schedule Congestion Adjustment will be included in the CRR balance account
- For non-ISO EDAM BAA, OATT balanced self-schedule Congestion Adjustment will be included in the EDAM Congestion Offset
- Enable EDAM entity to sub-allocate these revenues under the terms of their OATT

 California ISO	Technology	Template Version:	6.8
		Document Version:	6.1.7
Extended Day Ahead Market Business Requirements Specification - Planning		Date Created:	1/21/2026

5.14.1 Business Requirements

ID#	Business Feature	Requirement Type	Potential Application(s) Impacted
EDAM-CRA-BRQ-06030	Input data for the congestion revenue adjustment: <ul style="list-style-type: none"> • IFM resource awards (Hourly), both physical and virtual should be considered, for CAISO and EDAM BAAs in EDAM footprint, Schedule breakdown with CRN • MF CRN and financial flag • MF TIE to ITC mapping • MF SP to TIE mapping • CRN entitlement for CISO BAA CRN update • SIBR CRN Entitlements for EDAM BAA CRN update • IFM Shift factors/aggregated shift factor data • IFM Shadow prices, for flowgates, ITCs, ISLs, nomograms, and nodal group constraints and associated BAA • CRR ownership (TOU) • Prorated Clawback Revenue • Clawback MW • Hourly Circular scheduling revenue • Hourly Circular scheduling MW (revenue/shadow price) 	Core	Internal ISO System
EDAM-CRA-BRQ-06032a	Map CRR ownership source and/or sink which are located at CAISO scheduling point (SP) with an implied tie based on the SP to SGAP-TIE mapping	Core	Internal ISO System
EDAM-CRA-BRQ-06031	Calculate IFM total, CRN flow, and CRR flow for binding ITC/ISLs based on resource tie information and tie to ITC mapping. <ul style="list-style-type: none"> • Include self-schedule or bids submitted at DGAP-Tie, SGAP-Tie in the corresponding ITC/ISL constraint according to Tie-ITC mapping • For the binding ITC/ISL constraint, include schedule (including TSR) at Tie in IFM flow and in CRN flow for the schedule with CRN 	Core	Internal ISO System

 California ISO	Technology	Template Version:	6.8
		Document Version:	6.1.7 1.7
Extended Day Ahead Market Business Requirements Specification - Planning		Date Created:	1/21/2026

ID#	Business Feature	Requirement Type	Potential Application(s) Impacted
EDAM-CRA-BRQ-06030a	<p>Notation</p> <p>N: number of nodes on the system indexed by n</p> <p>T: numbers of intervals indexed by t</p> <p>J: number of BAAs in the EDAM footprint, index by j; j=1 for CISO.</p> <p>M: number of binding constraints in IFM, indexed by m</p> <p>M_j: number of binding constraints in IFM in BAA j, j=1 CAISO</p> <p>K: number of constraint cases (including the base case, contingencies) in IFM, indexed by k</p> <p>Q: numbers of CRRs (only with source/sink in CISO), indexed by q</p> <p>$SF_{n,s,k,m,t}$ Shift factor of node n to constraint m under contingency k deployment scenario s interval t</p> <p>$\mu_{s,k,m,t}$: shadow price for constraint m in constraint case k at interval t for s deployment scenario</p> <p>DIR_s: IR deployment factor for s deployment scenario.</p> <p>S: types of deployment scenarios, including base, IRU deployment, IRD deployment, indexed by s</p> <p>$CRRMW_q$: CRR award q</p> <p>$CRNMW_{n,t}$: Contract schedule at node n interval t</p> <p>$IFMMW_{n,t}$: IFM energy schedule at node n interval t</p> <p>$IRMW_{s,n,t}$: IFM Imbalance Reserve (IRU/IRD) schedule at deployment scenario s node n interval t</p>	Process	Internal ISO System
EDAM-CRA-BRQ-06035	<p>Calculate CRN balanced schedules in EDAM area</p> <ul style="list-style-type: none"> • Identify the eligible schedule MW of resources that associate CRN with financial right flag Y <ul style="list-style-type: none"> ○ CRNMW include OATT1, OATT2, ETC/TOR MW at node n in EDAM footprint, interval t <p style="text-align: center;">$CRNMW_{n,t}$</p> <ul style="list-style-type: none"> • Calculate CRN balanced portion of CRN schedule 	Core	Internal ISO System

 California ISO	Technology	Template Version:	6.8
		Document Version:	6.1.7 1.7
Extended Day Ahead Market Business Requirements Specification - Planning		Date Created:	1/21/2026

ID#	Business Feature	Requirement Type	Potential Application(s) Impacted
	<ul style="list-style-type: none"> • For each CRN in each BAA, the system shall sum up the supply and demand schedules in that BAA associated with that CRN. For each CRN in each BAA, the system shall balance the supply and demand self-schedules in that BAA associated with that CRN. The total balanced quantity of a contract is determined by the lower of: the total source quantities, (the total sink quantities)*(-1), • Cap the balanced schedule on applicable contract Entitlement <ul style="list-style-type: none"> ○ If the total Supply exceeds the total demand, the balanced supply CRN schedules shall be calculated by reducing the original CRN schedules pro rata by the difference between the total supply and the total demand. If the total demand exceeds the total supply, the balanced demand CRN schedules shall be calculated by reducing the market CRN schedules pro rata by the difference between the total demand and the total supply. 		
EDAM-CRA-BRQ-06036	<p>Set IFM flow, CRN flow, IR flow by constraint m by contingency k, deployment scenario s by interval t, for all the binding constraints in EDAM footprint</p> <p>For each binding constraint of (m,k,s,t):</p> <ul style="list-style-type: none"> • Calculate IFM flow as the summarize product of shift factor and IFM energy schedule at the node for all nodes. • Calculate CRN flow as the summarize product of shift factor and CRN contract balanced schedule at the node for all nodes. • Calculate IR flow as the summarize product of shift factor, deployment factor, and IFM energy schedule at the node, for all nodes 	Core	Internal ISO System
EDAM-CRA-BRQ-06038	<p>Determine CRR prevailing flow direction based on IFM total flow</p> <ul style="list-style-type: none"> • Calculate IFM total flow as IFM flow plus IR flow. IFM total flow is to determine the prevailing direction for CRR. 	Core	Internal ISO System

 California ISO	Technology	Template Version:	6.8
		Document Version:	6.1.7 1.7
Extended Day Ahead Market Business Requirements Specification - Planning		Date Created:	1/21/2026

ID#	Business Feature	Requirement Type	Potential Application(s) Impacted
	<ul style="list-style-type: none"> CRR flow is in the prevailing direction if the CRR flow value is the same sign as IFM total flow by constraint m by contingency k by deployment scenario s by interval t 		
EDAM-CRA-BRQ-06040	Calculate Hourly CRR net flow by constraint m by contingency k in all EDAM BAAs by scenario s by interval t <ul style="list-style-type: none"> CRR net flow is CRR nominal flow MW reduced by Clawback flow MW and circular schedule flow MW for that constraint 	Core	Internal ISO System
EDAM-CRA-BRQ-06041	Calculate Hourly IFM net flow by constraint m by contingency k in EDAM by scenario s by interval t <ul style="list-style-type: none"> Calculate IFM net flow as IFM flow plus IR flow minus CRN flow. IFM net flow is to fund CRR 	Core	Internal ISO System
EDAM-CRA-BRQ-06042	Calculate congestion flow difference (CFD) <ul style="list-style-type: none"> Calculate CFD between the IFM net flow and the CRR net flows by constraint m of EDAM by contingency by contingency by interval 	Core	Internal ISO System
EDAM-CRA-BRQ-06044	Calculate the Alpha ($\alpha_{q,s,k,m,t}$), the proportion (%) of the CRR net flow (prevailing direction) to all aggregated CRRs net flow by constraint m in EDAM by contingency k by scenario s by interval t <ul style="list-style-type: none"> For each CRR, for each binding constraint, calculate the portion of the CRR net flow over the all CRRs net flows for the constraint prevailing direction 	Existing	Internal ISO System
EDAM-CRA-BRQ-06046	Calculate Offset MW for each CRR as proportion of CFD by constraint of EDAM by contingency by scenario by interval <ul style="list-style-type: none"> For each binding constraint in EDAM, calculate Offset MW for each CRR q as product of the portion and congestion flow difference (CFD) 	Existing	Internal ISO System
EDAM-CRA-BRQ-06032	Calculate CRR hourly Notional Revenue for all constraints in EDAM area by constraint m by contingency k, by scenario s by interval t	Core	Internal ISO System

 California ISO	Technology	Template Version:	6.8
		Document Version:	6.1.7
Extended Day Ahead Market Business Requirements Specification - Planning		Date Created:	1/21/2026

ID#	Business Feature	Requirement Type	Potential Application(s) Impacted
	<ul style="list-style-type: none"> For each CRR, for each constraint in EDAM: calculate CRR notional value as the product of CRR flow on the constraint and shadow price of the constraint. 		
EDAM-CRA-BRQ-06033	Calculate offset revenue by constraint m of EDAM by contingency k, by scenario s by interval t <ul style="list-style-type: none"> For each CRR, for each constraint in EDAM: calculate CRR offset revenue as the product of CRR offset MW and shadow price of the constraint 	Core	Internal ISO System
EDAM-CRA-BRQ-06034	Calculation for EDAM footprint <ul style="list-style-type: none"> Hourly CRR Clawback Revenue and MW: the amount which has been prorated, by scenarios for all the constraints in EDAM footprint (EDAM-CRA-BRQ-06034a) Hourly Circular Scheduling Revenue and MW: the user entered amount MW (EDAM-CRA-BRQ-06034b) 	Core	Internal ISO System
EDAM-CRA-BRQ-06034a	Expand Calculation CRR Claw Back revenue and MW to the constraints in EDAM BAAs <ul style="list-style-type: none"> Include Virtual Bids impact on Base and IRU/IRD deployment scenario binding constraints in CRR Claw back for all EDAM BAAs 	Core	Internal ISO System
EDAM-CRA-BRQ-06034b	Expand Calculation CRR Circular schedule revenue and MW to the constraints in EDAM BAAs <ul style="list-style-type: none"> Receive Circular schedules MW in EDAM footprint Calculate Circular Schedule impact on binding constraints in EDAM through product of shift factor and Circular schedules MW Calculate Hourly Circular Scheduling Revenue 	Core	Internal ISO System
EDAM-CRA-BRQ-06048	Calculate Daily Revenue of each CRR as summary of revenue of the hours of the day by constraint m of EDAM by contingency k by scenario s: <ul style="list-style-type: none"> For each CRR, calculate daily revenue and summarize hourly value for <ul style="list-style-type: none"> Notional Revenue Offset Revenue Clawback Revenue 	Existing	Internal ISO System

 California ISO	Technology	Template Version:	6.8
		Document Version:	6.8 1.7
Extended Day Ahead Market Business Requirements Specification - Planning		Date Created:	1/21/2026

ID#	Business Feature	Requirement Type	Potential Application(s) Impacted
	<ul style="list-style-type: none"> o Circular Scheduling Revenue 		
EDAM-CRA-BRQ-19710	<p>Use CRR settlement existing logic with consume new attributes BAA and deployment scenario</p> <p>CRR settlement logic using CRRS calculated daily and hourly</p> <ul style="list-style-type: none"> • Notional revenue, • Offset revenue that reflect adjustment for the CRN congestion revenue, • Clawback revenue, • Circular schedule revenue <p>Note: the CRN parallel flow congestion revenue is included in offset revenue.</p>	Core	Settlements
EDAM-CRA-BRQ-19720	<p>Include in CRR balancing Account the CRN parallel flow congestion revenue adjustment for CAISO BAA</p> <p>CRR Balancing Account is the net of:</p> <ul style="list-style-type: none"> • IFM Energy Congestion Revenue (CAISO Constraints) • IFM Virtual Bid Congestion Revenue (CAISO Constraints) • IFM Imbalance Reserve Congestion Revenue (CAISO Constraints) • IFM CAISO BAA Ancillary Service Congestion Revenue, • CRR1B Settlement Amount, • CRR Auction Amount, • ETC/TOR Congestion Credit (CAISO Constraints), • OATT Congestion Adjustment – new item that exclude eligible parallel flow congestion revenue on the CAISO constraints <p>CRR Balancing Account Neutrality Amount is allocated to CAISO Measured Demand</p>	Core	Settlements
EDAM-CRA-BRQ-19730	<p>Calculate the hourly balanced CRN (OATT) self-schedules</p> <ul style="list-style-type: none"> • The system shall calculate the balanced CRN self-schedule for OATT in the same manner as ETC: 	Core	Settlements

 California ISO	Technology	Template Version:	6.8
		Document Version:	4.6 1.7
Extended Day Ahead Market Business Requirements Specification - Planning		Date Created:	1/21/2026

ID#	Business Feature	Requirement Type	Potential Application(s) Impacted
	<ul style="list-style-type: none"> ○ CRNs can be single or linked to facilitate the implementation of certain contracts that require interconnection across transmission rights. – used for parallel flow calculation ● Receive IFM OATT CRN Resource self-schedules by resource by hour ● Set the Balanced Resource OATT CRN self-schedule – for all OATT <ul style="list-style-type: none"> ○ For each CRN in each BAA, the system shall balance the supply and demand self-schedules in that BAA associated with that CRN. The total balanced quantity of a contract is determined by the lower of: the total source quantities, (the total sink quantities)*(-1), ○ Cap the applicable contract to Entitlement ○ for the relevant contract, Settlement Period or Settlement Interval, and market Reducing the original SIBR CRN schedules pro rata by the difference between the total demand and the total supply. ● Include OATT in existing logic for TOR/ETC <ul style="list-style-type: none"> ○ Set the balanced resource CRN schedule for single and for each segment in chain CRNs. 		
EDAM-CRA-BRQ-19740	Calculate OATT CRN parallel flow congestion credit by BAA <ul style="list-style-type: none"> ● Receive MF OATT CRN with Financial Flag <ul style="list-style-type: none"> ○ CRNs can be single or linked to facilitate the implementation of certain contracts that require interconnection across transmission rights. – used for parallel flow calculation ● Calculated balanced OATT CRN schedule energy above BRQ-19730 ● Receive nodal MCC breakdown by BAA - existing 	Core	Settlements

 California ISO	Technology	Template Version:	6.8
		Document Version:	6.1.7 1.7
Extended Day Ahead Market Business Requirements Specification - Planning		Date Created:	1/21/2026

ID#	Business Feature	Requirement Type	Potential Application(s) Impacted
	<ul style="list-style-type: none"> For balanced OATT CRN schedule energy where financial flag is Y, calculate the congestion credit by BAA and CRN for the valid and balanced portion of OATT Self-Schedules using the MCC by BAA at the relevant financial node (PNode, APNode, or PNode/APNode in combination with Intertie) associated with the OATT source or sink. The Congestion credit by CRN by BAA breakdown of OATT shall be (1) the product of the DA computed valid and balanced self-schedules at a supply resource and the MCC by BAA of the contract's financial source node associated with that resource, minus (2) the product of the DA computed valid and balanced self-schedules at a sink resource and the MCC of the contract's financial sink node associated with that resource. Calculate the BAA congestion credit where node schedule located as sum of congestion credit by CRN by MCC breakdown 		
EDAM-CRA-BRQ-19750	<p>Calculate each BAA IFM Energy Congestion Revenue, ETC/TOR Congestion Credit, OATT Congestion Adjustment separately</p> <ul style="list-style-type: none"> IFM Energy Congestion Revenue by BAA on the BAA Constraints (without reversal ETC/TOR, OATT MCC charge) ETC/TOR balanced self-schedule Congestion Credit OATT balanced self-schedule Congestion Adjustment – Credit and reversal, <p>Note: Eligible parallel flow congestion credit for the entity where schedule located, reversal for the entity where congestion located</p>	Core	Settlements
EDAM-CRA-BRQ-19760	<p>Manage OATT balanced self-schedule Congestion Adjustment, credit to EDAM entity schedule where located, reversal to EDAM entity where congestion located</p>	Core	Settlements

 California ISO	Technology	Template Version:	6.8
		Document Version:	6.1.7
Extended Day Ahead Market Business Requirements Specification - Planning		Date Created:	1/21/2026

ID#	Business Feature	Requirement Type	Potential Application(s) Impacted
	<ul style="list-style-type: none"> • The Congestion Charges for valid and balanced portion of each OATT contract Self-Schedules shall all be credited only to the EDAM entity SC for the BAA where the resource located <ul style="list-style-type: none"> ○ Enable EDAM entity to sub-allocate this revenue under the term of their OATT transmission right <p style="margin-left: 40px;">Note: CRN Financial SC of OATT must be EDAM entity SC defined in MF</p> • The reversal of Congestion Charges for valid and balanced portion of each OATT contract Self-Schedules shall be credited only to the EDAM entity SC for the BAA that congestion constraint located 		
EDAM-CRA-BRQ-19760a	Manage ETC/TOR balanced self-schedule Congestion Adjustment, credit to Billing SC, reversal to ISO BAA and other EDAM BAA where congestion located <ul style="list-style-type: none"> • Adjust offset to the congestion of the BAA where constraint is located 	Core	Settlements
EDAM-CRA-BRQ-19770	Calculate the Day-ahead hourly Marginal Congestion Offset for each EDAM BAA <ul style="list-style-type: none"> • DAM Marginal Congestion Offset: sum of product of BAA energy schedule, (includes schedules for virtual awards and energy transfer schedule, Imbalance Reserve schedule) and MCC breakdown of the EDAM BAA, • The hourly Day-Ahead Congestion revenue amount shall also account for any ETC/TOR marginal Congestion adjustment amounts and OATT balanced self-schedule Congestion Adjustment 	Core	Settlements
EDAM-CRA-BRQ-19770a	For CAISO BAA, OATT balanced self-schedule Congestion Adjustment will be included in the CRR balance account	Core	Settlements
EDAM-CRA-BRQ-19770b	For other EDAM BAAs, OATT balanced self-schedule Congestion Adjustment will be included in the EDAM Congestion Offset	Core	Settlements

 California ISO	Technology	Template Version:	6.8
		Document Version:	4.6 1.7
Extended Day Ahead Market Business Requirements Specification - Planning		Date Created:	1/21/2026

ID#	Business Feature	Requirement Type	Potential Application(s) Impacted
	<ul style="list-style-type: none"> OATT balanced self-schedule Congestion Adjustment will be included in the EDAM Congestion Offset OATT congestion adjustment shall not impact RTM offset, OATT adjustment only apply DAM. 		
EDAM-CRA-BRQ-19780	<p>No Changes to Settlements for MSS modeled in CISO BAA</p> <ul style="list-style-type: none"> For an MSS under GROSS Energy Settlement, the payment for Supply equals the product of: (1) the MWh quantity of Supply in the SC's Day-Ahead Schedule (excluding ETC/TOR schedules) at the corresponding PNode and (2) the applicable resource-specific LMP at that PNode. For an MSS under NET Energy Settlement, the charge for Demand equals the product of: (1) the net MSS Demand calculated from the Day-Ahead Schedules (excluding ETC/TOR schedules) and (2) the MSS LAP LMP Price. The weights used to compute the weighted average LMPs shall be equal to the Energy Schedule of MSS Generation included in the Day-Ahead Schedule (excluding ETC/TOR schedules). No MSS modeled in non-ISO EDAM BAA 	Existing	Settlements
EDAM-CRA-BRQ-19790	<p>The IFM Congestion Credit to designated Billing SC for valid and balanced portion of ETC/TOR/CVR Self-Schedule for Trading Hour h. (\$)</p>	Existing	Settlements
EDAM-CRA-BRQ-19790a	<p>The OATT Congestion Credit to EDAM entity SC as designated Billing SC for valid and balanced portion of OATT Self-Schedule for Trading Hour h. (\$)</p> <p>Note: Enables EDAM entity to sub-allocate these revenues under the terms of their OATT to provide congestion cost protections for exercise of transmission rights.</p>	Core	Settlements

 California ISO	Technology	Template Version:	6.8
		Document Version:	4.6 1.7
Extended Day Ahead Market Business Requirements Specification - Planning		Date Created:	1/21/2026

ID#	Business Feature	Requirement Type	Potential Application(s) Impacted
EDAM-CRA-BRQ-20176b	Report CRR Revenue Adjustments Details on CMRI Receive Hourly CRR Revenue Adjustment Data from CRRS Report CRR Revenue Adjustments Data for SC, by constraint by CRR <ul style="list-style-type: none"> • Notional Revenue • Offset Revenue • Claw back revenue • Circular Scheduling Revenue • Derate Factor • CRR Award MW 	Existing	CMRI
EDAM-CRA-BRQ-20277b	Report CRR Aggregated Revenue Adjustments Data on OASIS Receive Hourly CRR Revenue Adjustment Data from CRRS Report CRR Aggregated Revenue Adjustments Data, add CRN net flow <ul style="list-style-type: none"> • Total Notional value, • Total Offset Value • Total Clawback Revenue • Total Circular Schedule Revenue • IFM net Flow 	Existing	OASIS

 California ISO	Technology	Template Version:	6.8
		Document Version:	4.6 1.7
Extended Day Ahead Market Business Requirements Specification - Planning		Date Created:	1/21/2026

5.15 Business Process: Manage Billing and Settlements (Settlements)

- Settle DA TSR for energy, IRU/IRD, RCU/RCD
- EDAM RSE failure surcharge and allocation
- DAM Settlements for EDAM resource energy, IRU/IRD, RCU/RCD
- DAM BCR
- DAM GHG Settlements
- EDAM legacy contract settlements
- Neutrality
- RTM Imbalance energy Settlements refer to DAM schedule
- EIM ETSR Settlements
- RUC, RTM BCR
- GMC for EDAM
- Transmission Revenue Recovery (TRR) settlements
- Consume All CRN MW Entitlements

5.15.1 Business Requirements

ID#	Business Feature	Requirement Type	Potential Application(s) Impacted
EDAM-BRQ-19010	<p>Consume EDAM IFM and RUC market data</p> <p>Consume EDAM resource, nodal and network constraint hourly market data same as for CAISO resource nodal and constraint data in DAM</p> <ul style="list-style-type: none"> • All the EDAM resource ID, physical and virtual and attributes - from MF and market • Clean and final bids for energy, IRU/IRD, RCU/RCD • Resource Awards for energy, AS, IRU/IRD, RCU/RCD • Resource and nodal prices, SP-Tie and components breakdown: energy, congestion by BAA, loss, GHG by GHG area • EDAM LAP, CLAP prices for energy • EDAM IRU/IRD Hub price and breakdown (Market) 	Existing	Settlements

 California ISO	Technology	Template Version:	6.8
		Document Version:	6.1.7
Extended Day Ahead Market Business Requirements Specification - Planning		Date Created:	1/21/2026

ID#	Business Feature	Requirement Type	Potential Application(s) Impacted
	<ul style="list-style-type: none"> • EDAM BAA IRU/IRD IFM cleared requirement and relaxation • Binding Constraint and shadow price by BAA • BAA requirements for Energy, AS, IRUR/IRDR • BAA IRUS/IRDS • BAA Associated Imbalance Demand Hub Apnode 		
EDAM-BRQ-19014	Consume EDAM market results <ul style="list-style-type: none"> • Resource expected energy (EE), EE allocation and commitment cost (AUX cost) • Resource FMM ex-post capacity and allocation • Resource DAM 5 minute ramp-capable portion for Imbalance reserve • CRRS (CRR 1B) outputs by constraint–current design 	Existing	Settlements
EDAM-BRQ-19020	Access MF Data System shall have the capability to automatically access and store the following data: <ul style="list-style-type: none"> • Registered CRN definition and resource association • WECC on-peak definition from MF (6 am-10pm Monday through Saturday, except holidays) • WECC off-peak definition from market (10pm-12 am, 12 am-6am) Monday through Saturday, whole day of Sunday and holidays) 	Core	Settlements
EDAM-BRQ-19022	Consume 16-Hour Block Priced at Hub (PV, Mid-C) On daily basis, System shall consume the following data: <ul style="list-style-type: none"> • Bilateral trading Mid-C, PV Hub priced for Settlements surcharge for the BAA failed DA-RSE. 	Existing	Settlements
EDAM-BRQ-19025	Consume All CRN MW Entitlements System shall receive MW entitlement data with SC-submitted respective self-schedules for all CRNs after the market	Core	Settlements
EDAM-BRQ-19026	Consume DA CRN TSR Market Data from IFM Upon IFM market run, and similar to other IFM data, System shall consume the following IFM market results data:	Core	Settlements

 California ISO	Technology	Template Version:	6.8
		Document Version:	6.1.7 1.7
Extended Day Ahead Market Business Requirements Specification - Planning		Date Created:	1/21/2026

ID#	Business Feature	Requirement Type	Potential Application(s) Impacted
	<ul style="list-style-type: none"> • EDAM Transfer resource (DA TSR) IFM hourly awards/schedules of energy, AS, IRU/IRD • DA TSR IFM hourly prices for Energy, AS, IRU/IRD • Any other resource with an association to a CRN (need to receive limits from market for any short-term rights sold) 		
EDAM-BRQ-19028	Consume DA TSR Market Data from RUC Upon RUC market run, and similar to other RUC data, System shall consume the following RUC market results data: <ul style="list-style-type: none"> • DA TSR RUC hourly awards/Price of RCU/RCD 	Core	Settlements
EDAM-BRQ-19030	Consume DA RSE Deficiency and Procurement Requirement that include DB for EDAM BAA from DA-RSE Upon DA-RSE run, System shall consume the following DA-RSE market results data: <ul style="list-style-type: none"> • Hourly EDAM BAA <ul style="list-style-type: none"> ○ RSE success/failure flags for upward and downward capacity ○ RSE upward requirement, requirement with DB and deficiency flag and amount (relax variable value) by commodities of upward Energy, RegU, Spin, NSpin, and IRU, deficiency upward (Energy&IRU) ○ RSE downward requirement, requirement with DB and deficiency flag and amount by Energy, RegD, and IRD, deficiency downward (energy&IRD) 	Core	Settlements
EDAM-BRQ-19042	Fallback option for 16 hour block Hub price <ul style="list-style-type: none"> • For the fallback in cases where the bilateral index prices are not broadcasted to Settlements: If the data is not consumed by Settlements, it should use the most recently available on-peak prices. 	Core	Settlements
EDAM-BRQ-19050	Consume GHG MW and GHG price <ul style="list-style-type: none"> • Consume GHG constraint shadow price by GHG regulation area by hour – from IFM 	Core	Settlements

 California ISO	Technology	Template Version:	6.8
		Document Version:	6.8 1.7
Extended Day Ahead Market Business Requirements Specification - Planning		Date Created:	1/21/2026

ID#	Business Feature	Requirement Type	Potential Application(s) Impacted
EDAM-BRQ-19051	Consume GHG MW and GHG price <ul style="list-style-type: none"> Consume resource deemed GHG MW by GHG regulation area by hour – from IFM 	Core	Settlements
EDAM-BRQ-19052	Consume DA TSR, Dynamic and static TSR schedules from RTPD and RTD <ul style="list-style-type: none"> Consume DA TSR schedule and attributes -include pathway, CRN (with enumeration contract type of TOR/ETC/OATT 1/OATT 2) from RTPD and RTD Consume Static and dynamic TSR schedule from RTPD and RTD 	Core	Settlements
EDAM-BRQ-19055	System shall consume interchange schedule breakdown by CRN data for EDAM/WEIM entities by market resource awards <ul style="list-style-type: none"> EDAM/WEIM entities shall submit breakdown by CRN data via RTSI Consumed from RTSI Map CRN 	Core	Settlements
EDAM-BRQ-19056	System shall consume interchange schedule breakdown by CRN data for CAISO BA <ul style="list-style-type: none"> Map CRN 	Existing	Settlements
EDAM-BRQ-19060	IFM Energy, AS, convergence bids, IRU/IRD, RCU/RCD payment for EDAM resource-same as ISO resources in DAM: <ul style="list-style-type: none"> Hourly Energy supply and demand, CB of supply/demand schedule/award at LMP, import/export at SP-Tie price Hourly IRU/IRD awards at locational IRUP/IRD price, import/export award at SP-Tie IRU/IRD price Hourly Settlements for AS at ASMP for the ISO (existing). No AS Settlements for EDAM BAA Hourly RCU/RCD award at locational RCUP/RCDP, import/export at SP-Tie RCU/RCD price 	Core DAME	Settlements
EDAM-BRQ-19062	Extend DAM cost allocation for commodities to EDAM BAA	Core	Settlements

 California ISO	Technology	Template Version:	6.8
		Document Version:	6.1.7 1.7
Extended Day Ahead Market Business Requirements Specification - Planning		Date Created:	1/21/2026

ID#	Business Feature	Requirement Type	Potential Application(s) Impacted
	<ul style="list-style-type: none"> • Extend to EDAM BAA DAM two tier cost allocation rules for energy. • AS Settlements for ISO - existing • Extend DAME two tier cost allocation for IRU/IRD, RCU/RCD cost allocation to EDAM BAA <p>For IRU/IRD</p> <ul style="list-style-type: none"> • Tier 1 to the FMM and DA deviation of resources of the BAA for ISO only • Tier 2 remainder to metered demand of the BAA for ISO, direct assignment to EDAM BAAs <p>For RCU/RCD:</p> <ul style="list-style-type: none"> • Tier 1 CB and load deviation for ISO and EDAM elected CB • Tier 2 remainder to metered demand for ISO, direct assignment to EDAM BAAs/Gen-only entity 	DAME	
EDAM-BRQ-19063	<p>Calculate Internal Congestion Revenue for EDAM Entity</p> <ul style="list-style-type: none"> • System shall calculate congestion revenue based on price differences in the MCC of the LMP across PNodes and interties within the EDAM Area. <p>Note: For the CAISO BAA, the congestion revenue associated with ISO allocation will be subject to Tariff §11 and adjusted for the ISO contracts.</p>	Core	Settlements
EDAM-BRQ19063a	<p>OATT 1 and OATT 2 transmission contract types shall have scheduling priority similar to ETC/TOR, but OATT 1 and OATT 2 do not have financial hedge as provided to ETC and TOR</p> <p>Notes:</p> <ul style="list-style-type: none"> • OATT 1: higher scheduling priority in RT than DA schedules • OATT 2: equal scheduling priority with DA schedules in RT • All other attributes for OATT 1 and OATT 2 are the same 	Process	Settlements

 California ISO	Technology	Template Version:	6.8
		Document Version:	4.61.7
Extended Day Ahead Market Business Requirements Specification - Planning		Date Created:	1/21/2026

ID#	Business Feature	Requirement Type	Potential Application(s) Impacted
EDAM-BRQ-19064	<p>Allocate Internal Congestion Revenue to EDAM Entity</p> <ul style="list-style-type: none"> System shall allocate collected EDAM BAA congestion revenue, adjusted for the EDAM contracts, to the EDAM Entity. <p>Note: For the CAISO BAA, the congestion revenue associated with ISO allocation will be subject to Tariff §11 and adjusted for the ISO contracts.</p>	Core	Settlements
EDAM-BRQ-19070	<p>DAM resource GHG payment</p> <ul style="list-style-type: none"> Access resource-specific MF defined flag for GHG regulation area Settlements Settle resource GHG payment as the product of Deemed GHG MW (attribution) of the GHG regulation area and GHG marginal GHG price for the GHG regulation area by hour for the resource 	Core	Settlements
EDAM-BRQ-19075	<p>Include DAM GHG in GHG regulation area neutrality</p> <p>In DAM neutrality Settlements for EDAM footprint:</p> <ul style="list-style-type: none"> Marginal GHG Offset for each GHG regulation area is the sum of the product of energy/CB award payment and MGC - GHG payment for that regulation area, allocate to that GHG regulation area's metered demand 	Core	Settlements
EDAM-BRQ-19080	<p>Extend non-compliance in DAME to EDAM</p> <ul style="list-style-type: none"> No change for ISO resource AS no-pay rule <ul style="list-style-type: none"> Do not apply AS no-pay rule to EDAM BAA Non-compliance for IRU/IRD for the portion of excess 5-min ramp capability through IFM IRU/IRD schedule, at the higher price of (IRP, FMM FRP, RTD FRP) for EDAM BAA and ISO Non-compliance for RCU/RCD portion in RTM will claw-back the RCU/RCD payment for EDAM BAA and ISO 	Core DAME	Settlements
EDAM-BRQ-19090	<p>Calculate IFM Bid cost recovery for resource</p> <ul style="list-style-type: none"> IFM Commitment period, for each EDAM BAA, the value of Res IFM daily revenue (EN/IR/AS (for ISO) payment) including RES GHG revenue does not cover the cost (cost of Startup, min load, transition, 	Core DAME	Settlements

 California ISO	Technology	Template Version:	6.8
		Document Version:	6.1.7 1.7
Extended Day Ahead Market Business Requirements Specification - Planning		Date Created:	1/21/2026

ID#	Business Feature	Requirement Type	Potential Application(s) Impacted
	energy bid, AS bid (for ISO), IR bid include GHG bid cost) is eligible for IFM BCR <ul style="list-style-type: none"> ○ Calculate GHG revenue as product of IFM GHG award and relevant MGC ○ Imbalance reserve (IR) IRU/IRD payment and bid cost 		
EDAM-BRQ-19100	IFM BCR adjustment calculation and transfer: <ul style="list-style-type: none"> • Calculate hourly BAA total IFM BCR amount • Adjustment based on transfer out for the BAA (payment) $\text{IFM BCR adjustment} = \text{BAA Total IFM BCR Amount} * (\text{Net transfer out} / \text{sum of } (\text{Net transfer out} + \text{IFM Load schedule} + \text{IFM virtual demand schedule} + \text{IFM Export Schedule}))$ • Calculate hourly distribution IFM BCR adjustment based on net transfer In for the BAAs (charge) $\text{IFM BCR Adjustment distribution} = \text{IFM BCR Adjustment} * \text{BAA Net IFM Transfer In} / \text{Total of BAA IFM Transfer In}$ • Distribute total IFM BCR adjustment proration to BAA net transfer in • Allocate net BCR adjustment (Total BAA BCR + BCR adjustment + BCR distribution by hour; can be payment or charge) for the BAA to the EDAM entity by hour • For ISO to allocate BCR adjustment amount, use existing two-tier BCR allocation 	Core	Settlements
EDAM-BRQ-19110	BAA DA-RSE Failure Surcharge Settlements – On-Peak Upward Deficiency <ul style="list-style-type: none"> • System shall calculate the surcharge for on-peak (PCT) for the failing RSE BAA on 16-hour block as the higher price of Hub (PV, Mid-C) based on max of hourly deficiency of the day, adjusted for credit for the hours passed, multiplied by failure scaling factors of tiers • System shall calculate the maximum of hourly upward deficiency of 16 hour of on-peak of the day 	Core	Settlements

 California ISO	Technology	Template Version:	6.8
		Document Version:	6.1.7 1.7
Extended Day Ahead Market Business Requirements Specification - Planning		Date Created:	1/21/2026

ID#	Business Feature	Requirement Type	Potential Application(s) Impacted
	<ul style="list-style-type: none"> ○ Deficiency of each hour is calculated by adding the value of deficiency upward of energy, IRU, RegU/Spin/NSpin of the hour. ● System shall calculate the surcharge Settlements for the EDAM BAA failed the RSE upward evaluation <ul style="list-style-type: none"> ○ Tier 1 <ul style="list-style-type: none"> ▪ Maximum hourly deficiency less than Max of 10 MW or BAA forecast error for IRU, no surcharge (But BAA is not eligible for surcharge revenue) <ul style="list-style-type: none"> ▫ Forecast error can be 1% (configurable) of IRU requirement in procurement that include DB ○ Tier 2 <ul style="list-style-type: none"> ▪ maximum hourly deficiency is less than the 50% procurement (DB included) requirement of IRU, calculate surcharge For 16 hour of on-peak in TD, calculate surcharge for each hour: $1.25 * [\max(0, (\max \text{ interval shortfall} * \text{ Hub price} - (\text{credit based on the weighted average IFM BAA LAP LMP for the BAA in RSE passed the hour})))]$ ○ Tier 3 <ul style="list-style-type: none"> ▪ Maximum hourly deficiency is larger than 50% procurement requirement IRU, calculate surcharge For 16 hour of on-peak in TD, each hour: $2 * [\max(0, (\max \text{ interval shortfall} * \text{ Hub price} - (\text{credit based on the weighted average IFM BAA LAP LMP for the BAA in RSE in passed the hour})))]$ 		
EDAM-BRQ-19115	BAA DA-RSE Failure Surcharge Settlements – Off-Peak Upward Deficiency System shall calculate Off-peak Upward deficiency surcharge on BAA LAP LMP, for each hour: <ul style="list-style-type: none"> ● Tier 1 	Core	Settlements

 California ISO	Technology	Template Version:	6.8
		Document Version:	6.1.7 1.7
Extended Day Ahead Market Business Requirements Specification - Planning		Date Created:	1/21/2026

ID#	Business Feature	Requirement Type	Potential Application(s) Impacted
	<ul style="list-style-type: none"> ○ Hourly deficiency less than max of 10 MW or BAA forecast error for IRU, no surcharge. BAA is not eligible for surcharge revenue • Tier 2 <ul style="list-style-type: none"> ○ Hourly deficiency is less than the 50% procurement requirement of IRU, calculate surcharge 1.25*[(interval shortfall*BAA LAP LMP load weighted average)] • Tier 3 <ul style="list-style-type: none"> ○ Hourly deficiency is larger than 50% requirement IRU, calculate surcharge 2.0*[(interval shortfall*BAA LAP LMP load weighted average)] 		
EDAM-BRQ-19120	<p>BAA DA-RSE Failure Settlements – Downward Deficiency</p> <p>For all the hours in any day, System shall calculate downward deficiency surcharge on BAA MEC LMP, for each hour:</p> <ul style="list-style-type: none"> • Calculate total amount of deficiency of each hour as the sum of downward deficiency of energy, IRD, RegD • Calculate downward deficiency surcharge as deficiency * BAA MEC LMP <p>Note</p> <ul style="list-style-type: none"> ○ For downward deficiency, <i>de Minimis</i> is 10.0 MW 	Core	Settlements
EDAM-BRQ-19130	<p>Increase Penalty 1% to On-Peak Upward Deficiency for every Additional Day of RSE Failure Retroactive 30 Day-Period</p> <ul style="list-style-type: none"> • For each EDAM BAA, System shall calculate the number of days on rolling 30 days for RSE upward failure (hours of upward failure count on-peak only) • System shall increase the penalty adders by 1% for every additional day a BAA failed the RSE test as an adder to tier 2 (base 1.25%) and tier 3 (base 2.0%) <ul style="list-style-type: none"> ○ Example: One additional failed day—tier 2 penalty becomes 1.2625%, tier 3 penalty becomes 2.02% <p>Note</p>	Core	Settlements

 California ISO	Technology	Template Version:	6.8
		Document Version:	4.6 1.7
Extended Day Ahead Market Business Requirements Specification - Planning		Date Created:	1/21/2026

ID#	Business Feature	Requirement Type	Potential Application(s) Impacted
	<ul style="list-style-type: none"> This penalty increase is not applicable for off-peak upward nor downward deficiency. 		
EDAM-BRQ-19140	<p>Allocate DA RSE failure surcharge to EDAM entity SC of BAA that failed DA RSE</p> <ul style="list-style-type: none"> Allocate each BAA surcharge to EDAM entity SC TBD: If ISO BAA receive the surcharge, then allocate per ISO EDAM BAA initiative <p>Note: Subject to CAISO EDAM Participation Rules Initiative</p>	Core	Settlements
EDAM-BRQ-19150	<p>Allocate DA RSE failure surcharge revenue to EDAM entity SC passed DA RSE, up/down separately</p> <ul style="list-style-type: none"> Allocate upward Surcharge Revenues to the EDAM BAA SCs with upward passed DA-RSE flags for all the hours of the day. An EDAM BAA will become ineligible for allocation of any upward surcharge revenue if it fails the EDAM RSE in the upward direction during any hourly interval across the day <ul style="list-style-type: none"> Allocate upward surcharge revenue pro-rata on volume of net export transfer, include energy transfer and IRU, RCU transfer of BAA by hour Allocate remaining upward surcharge revenue pro-rata to metered demand of BAA that passed upward test Allocate downward Surcharge Revenues to the EDAM BAA SCs with downward passed DA-RSE flags for all the hours of the day. An EDAM BAA will become ineligible for allocation of any downward surcharge revenue if it fails the EDAM RSE in the downward direction during any hourly interval across the day <ul style="list-style-type: none"> Allocate downward surcharge revenue pro-rata on net import transfer of BAA, include energy and IRD, RCD by BAA, hourly, Allocate remaining of downward surcharge revenue to the metered demand of BAA that passed DA-RSE downward test 	Core	Settlements
EDAM-BRQ-19160	<p>Backstop allocation: if no EDAM BAA avoids failure upward/downward for 24 hours, revert to hourly allocation</p>	Core	Settlements

 California ISO	Technology	Template Version:	6.8
		Document Version:	6.1.7 1.7
Extended Day Ahead Market Business Requirements Specification - Planning		Date Created:	1/21/2026

ID#	Business Feature	Requirement Type	Potential Application(s) Impacted
	<ul style="list-style-type: none"> • If no EDAM BAA pass all 24 hours the DA RSE upward test, revert to hourly <ul style="list-style-type: none"> ○ For each hour, the BAA that passed DA RSE upward test will be eligible to receive the upward surcharge revenue for the hour, same allocation pro-rata to BAA • If no EDAM BAA pass all 24 hours the DA RSE downward test, revert to hourly <ul style="list-style-type: none"> ○ For each hour, the BAA that passed DA RSE downward test will be eligible to receive the downward surcharge revenue for the hour, same allocation pro-rata to BAA net import • No EDAM passed for a given hour, then the Surcharge revenue allocation will not be collected 		
EDAM-BRQ-19165	<p>Calculate DA TSR Transfer Revenue for Energy, IRU/IRD and RCU/RCD</p> <ul style="list-style-type: none"> • System shall calculate the hourly DA TSR Transfer Revenue for each TSR for each commodity type as the product of DA TSR transfer quantity times the difference between import and export EDAM BAA locational price for the corresponding commodity type: <ul style="list-style-type: none"> ○ Energy: <ul style="list-style-type: none"> ▪ Energy Transfer quantity ▪ EDAM BAA IFM energy LMP component (MEC) ○ IRU/IRD <ul style="list-style-type: none"> ▪ IRU/IRD Transfer quantity ▪ EDAM BAA IFM IRU/IRD price. ○ RCU/RCD <ul style="list-style-type: none"> ▪ RCU/RCD Transfer quantity ▪ EDAM BAA RUC RCU/RCD price. • System shall calculate the hourly total DA TSR transfer revenue as the summation of DA TSR transfer revenues across all commodity types (Energy, IRU, IRD, RCU, and RCD). 	Core	Settlements

 California ISO	Technology	Template Version:	6.8
		Document Version:	6.1.7
Extended Day Ahead Market Business Requirements Specification - Planning		Date Created:	1/21/2026

ID#	Business Feature	Requirement Type	Potential Application(s) Impacted
EDAM-BRQ-19170	<p>Allocate DA TSR Transfer Revenue for Energy, IRU/IRD and RCU/RCD</p> <ul style="list-style-type: none"> • If the DA TSR is not a pathway 2, System shall allocate the DA TSR Transfer Revenue 50/50 (equally) between the two EDAM BAAs on each side of the TSR (including CAISO BAA). • DA-TSR pathway 2 direct Settlements <ul style="list-style-type: none"> ○ Consume DA TSR pathway 2 identifier from SIBR (transmission right released to the market in advance) ○ For pathway 2 DA TSR, SC of pathway 2 direct receives revenue. The DA TSR market award considers the curtailment; can be less than the transmission right originally released. • For CAISO BAA allocation, refer to ISO BAA EDAM Participation Rules Initiative 	Core	Settlements
EDAM-BRQ-19172	<p>RT energy TSR in RTM WEIM subject to Settlements</p> <ul style="list-style-type: none"> • Access MF defined base, static/dynamic WEIM TSR with associated SC, CRN, and NSC if applicable • Settle TSR with NSC if it is defined, or SC if there is no associated NSC • Consume the RTSI submitted self-schedule for the TSR with CRN • Settlements applies to both paired TSRs, • Settlements applies to all WEIM TSRs explicitly (note: a change from current WEIM) 	Core	Settlements
EDAM-BRQ-19173	<p>Calculate WEIM transfer Revenue</p> <ul style="list-style-type: none"> • Calculate EIM Transfer revenue <ul style="list-style-type: none"> ○ Product of transfer and BAA MEC ○ Add paired WEIM TSR revenues <p>Note: When the net EIM Transfer scheduling limit is binding, there will be separation of the Marginal Energy Cost (MEC) of the adjacent BAAs in the EIM. Then the EIM transfer revenue will be non-zero. If the limit is not binding, no separation of MEC of adjacent BAAs, therefore EIM transfer revenue will be zero.</p>	Core	Settlements

 California ISO	Technology	Template Version:	6.8
		Document Version:	6.1.7
Extended Day Ahead Market Business Requirements Specification - Planning		Date Created:	1/21/2026

ID#	Business Feature	Requirement Type	Potential Application(s) Impacted
EDAM-BRQ-19174	<p>Allocation WEIM transfer revenue</p> <ul style="list-style-type: none"> • Allocate transfer 50%:50% equally to the BAAs of each side of intertie, EIM entity will sub-allocate <p>Except specified sharing arrangement as following:</p> <ul style="list-style-type: none"> • For the CAISO BAA, allocate to SC of ETC/TOR holders consistent with the terms of the agreement concerning use of the transmission facilities supporting the EIM Transfer; • For an EIM Entity BAA that does not participate in the Day-Ahead Market in accordance with the associated EIM Transmission Service Provider tariff; and • For a WEIM Entity BAA that participates in EDAM <ul style="list-style-type: none"> ○ TSR are not pathway 2, allocate the EIM Transfer revenue to the EIM Entity Scheduling Coordinator for further allocation by the EIM Transmission Service Provider in accordance with its tariff, ○ TSR is <i>pathway 2</i>, allocate the EIM Transfer revenue to the Scheduling Coordinator for the EDAM Transmission Service Provider customer, or ○ TSR is EDAM Legacy Contact or EDAM Transmission Ownership Right, allocate the EDAM Transfer revenue to the Scheduling Coordinator for the EDAM Legacy Contact or EDAM Transmission Ownership Right holder, respectively. <ul style="list-style-type: none"> ○ Perfect hedge for the TSR that associate with CRN (ETC/TOR), ○ The cost goes to imbalance energy offset 	Core	Settlements
EDAM-BRQ-19175	<p>Settlements for EDAM legacy Contracts, Ownership rights (ETC/TOR/OATT 1/ OATT 2) with CRN- allocate to EDAM entity</p> <ul style="list-style-type: none"> • Access the resources with CRN from MF • SC Self-scheduled energy using their transmission right will settle at the LMP • For the balanced portion of schedule eligible for mitigation against Congestion 	Core	Settlements

 California ISO	Technology	Template Version:	6.8
		Document Version:	6.1.7
Extended Day Ahead Market Business Requirements Specification - Planning		Date Created:	1/21/2026

ID#	Business Feature	Requirement Type	Potential Application(s) Impacted
	<ul style="list-style-type: none"> ○ Settlements shall determine the balanced portion of the CRN between the sources and sinks and apply appropriate pro ration methodology between the resources that are providing the self-schedule hedge (existing functionality used for ETCs today—extending this functionality to EDAM). See EDAM-TSR-BRQ-19617 for CRN Balancing settlements. ○ Reversing the Marginal Cost of Congestion component of the LMP difference between the balanced source Day-Ahead Schedule and sink Day-Ahead Schedule, in the same manner as for ISO ETC/TOR ○ Include the congestion cost in the IFM congestion revenue offset—then allocate to EDAM entity ● The resourceTOR Contracts with special marginal losses provisions (defined in MFSettlements) will reverse the Marginal Cost of Losses component of the LMP <ul style="list-style-type: none"> ○ Allocate the Marginal Cost of Losses to EDAM entity 		
EDAM-BRQ-19176	Refund the cost with Financial SC for CRN <ul style="list-style-type: none"> ● If the CRN includes a financial right (marginal congestion and/or loss hedge), Settlements will refund the relevant cost (even if it is negative) to the Financial SC registered for the CRN (multiple SCs can self-schedule under the CRN, but only the Financial SC can receive the financial right) 	Core	Settlements
EDAM-BRQ-19200	DAM Neutrality Settlements: <ul style="list-style-type: none"> ● DAM Marginal Loss Offset: sum of product of BAA energy/CB award and MCL of EDAM BAA, allocate to EDAM entity and for ISO, to ISO measured demand ● DAM Marginal Congestion Offset: sum of product of BAA energy/CB award and MCC breakdown of the EDAM BAA, allocate to EDAM entity, for ISO to CRR balance account apply to ISO CRR -1B 	Core	Settlements

 California ISO	Technology	Template Version:	6.8
		Document Version:	6.1.7
Extended Day Ahead Market Business Requirements Specification - Planning		Date Created:	1/21/2026

ID#	Business Feature	Requirement Type	Potential Application(s) Impacted
	<ul style="list-style-type: none"> DAM Marginal GHG Offset: sum of BAA energy/CB award payment and MGC-GHG payment, allocate to GHG regulation area/non-GHG regulation area metered demand DAM Marginal energy offset: sum of BAA energy/CB award and LMP less the MCL/MCC/MGC offsets, allocate to EDAM entity and ISO measured demand 		
EDAM-BRQ-19210	<p>RTM Settlements: use EDAM DAM schedule instead of Base schedule</p> <p>Same as for CAISO, for EDAM Entities, WEIM shall use DAM schedule instead of the base schedule for reference point to calculate the imbalance energy.</p>	Core	Settlements
EDAM-BRQ-19220	<p>RTM Settlements: RTM Resource Energy deviation Settlements from EDAM, like ISO</p> <p>For EDAM resources:</p> <ol style="list-style-type: none"> FMM IIE, use IFM schedule as reference point Load UIE = load meter - IFM load schedule of EDAM BAA UIE and UFE apply to EDAM BAAs like ISO UFE selection apply to EDAM BAA (only deal with meter side of it) 	Core	Settlements
EDAM-BRQ-19230	<p>RTM Settlements: RTM Resource GHG deviation Settlements from EDAM</p> <ul style="list-style-type: none"> RTM GHG (FMM) is a deviation Settlement from IFM GHG Settlements (FMM GHG attribution less DAM GHG) for the external resources that serve GHG area load, pay to the resource RTM GHG (RTD) is a deviation Settlements from FMM GHG Settlements (RTD GHG less FMM GHG) for the external resource serve GHG area load, pay to the resource (existing) 	Core	Settlements
EDAM-BRQ-19240	<p>RTM Settlements: RTM Resource TSR deviation Settlements from EDAM</p> <ul style="list-style-type: none"> The CAISO will provide each EIM Entity with financially binding Settlements of Energy transfer 	Core	Settlements

 California ISO	Technology	Template Version:	6.8
		Document Version:	6.1.7
Extended Day Ahead Market Business Requirements Specification - Planning		Date Created:	1/21/2026

ID#	Business Feature	Requirement Type	Potential Application(s) Impacted
	schedule changes will be referenced from the Day-Ahead Schedule for the EDAM Transfer <ul style="list-style-type: none"> • RTM transfer TSR is a deviation Settlements from IFM Energy transfer <ul style="list-style-type: none"> ○ FMM transfer shall settle as a deviation from DA, if applicable (FFM IIE) at LMP* of SP-tie between WEIM BAAs, including the ISO ○ RTD transfer shall settle as a deviation from RT (RTD IIE) at LMP* of SP-tie between WEIM BAAs, including the ISO 		
EDAM-BRQ-19250	RTM Settlements: RTM Resource FRP forecast movement deviation Settlements from EDAM <ul style="list-style-type: none"> • Extending to EDAM • FRP forecast movement imbalance from IFM forecast movement and uncertainty is an imbalance Settlements of 5 minute ramp portion from DAM • FMM forecast – IFM (EDAM) or Base (EIM) forecast movement • For RTD to FMM no pay will not change 	Core	Settlements
EDAM-BRQ-19260	RTM Settlements: Under/over schedule charge shall not apply to EDAM BAAs Same as for CAISO in WEIM, no under/over schedule charge is applied to EDAM BAAs	Core	Settlements
EDAM-BRQ-19270	RTM Settlements: Treat EDAM pool, sub-pool of AET, non-AET as a super BAA <ul style="list-style-type: none"> • Consume the upward pool, sub-pool of AET/non-AET from market • WEIM RSE failure surcharge shall be applied to the insufficient amount of WEIM RSE the sub-pooled AET EDAM BAAs: <ul style="list-style-type: none"> ○ Allocate surcharge proportionally to net import transfer beyond net DAM/base net transfer BAAs in upward AET sub-pool • The Non-AET Sub-pool will not be subject to surcharge. 	Core	Settlements

 California ISO	Technology	Template Version:	6.8
		Document Version:	6.1.7
Extended Day Ahead Market Business Requirements Specification - Planning		Date Created:	1/21/2026

ID#	Business Feature	Requirement Type	Potential Application(s) Impacted
	<ul style="list-style-type: none"> AET surcharge revenue is allocated to the BAA that pass the RSE and have net export transfer beyond base net export transfer 		
EDAM-BRQ-19272	<p>For the upward Pool that passed EIM-RSE:</p> <ul style="list-style-type: none"> The pool is not subject to the AET surcharge, regardless BAA in the pool is a net import BAA Allocate the surcharge revenue to BAAs and the pool of BAAs that passed RSE, proportional to BAA/pool net transfer export beyond base For the pool that receives the surcharge revenue <ul style="list-style-type: none"> Allocate proportionally to the BAA in the pool that have net export transfer beyond base 	Core	Settlements
EDAM-BRQ-19274	<p>EDAM BAAs in the EDAM RSE downward pool will not be charged/receive AET surcharge/revenue, but can be added to the RT RSE pool</p>	Core	Settlements
EDAM-BRQ-19280	<p>RTM Settlements: Real Time Offset Settlements</p> <ul style="list-style-type: none"> Real Time Marginal Loss Offset is unchanged Real Time Congestion Offset <ul style="list-style-type: none"> Include any adjustment to account for schedules associated with EDAM transmission rights Real Time Imbalance Energy Offset: modified to account for imbalance energy, virtual bids at marginal energy cost <ul style="list-style-type: none"> Remove financial value transfer and GHG financial value RT offsets for each BAAs, allocate to EDAM/WEIM entity and ISO measured demand per tariff (existing) 	Core	Settlements
EDAM-BRQ-19282	<p>Access MF defined GHG area and associated DAM GHG area resources and RTM GHG area resources</p> <p>Example: CA: GHG area Associate: DAM: CAISO resources</p>	Core	Settlements

 California ISO	Technology	Template Version:	6.8
		Document Version:	6.1.7 1.7
Extended Day Ahead Market Business Requirements Specification - Planning		Date Created:	1/21/2026

ID#	Business Feature	Requirement Type	Potential Application(s) Impacted
	RTM: CAISO+LA+BANC resources		
EDAM-BRQ-19284	Real Time GHG Offset: <ul style="list-style-type: none"> • Imbalance energy, virtual bids MW in GHG regulation area at marginal GHG cost • Imbalance GHG attribution associated to the GHG regulation area and GHG marginal price • The offset determines if there is neutrality <ul style="list-style-type: none"> ○ Allocate neutrality to the GHG regulation area metered demand 	Core	Settlements
EDAM-BRQ-19286	DAM GHG Offset <ul style="list-style-type: none"> • Energy schedule/CB award and MGC-GHG price • GHG DAM attribution associated to the GHG regulation area and GHG marginal price • Allocate neutrality to GHG regulation area DAM IFM schedule load. 	Core	Settlements
EDAM-BRQ-19287	Intertie deviation penalty shall apply to ISO only <ul style="list-style-type: none"> • No Intertie Deviation penalty for other EDAM/WEIM BAAs, only for ISO 	Core	Settlements
EDAM-BRQ-19288	RT system offsets across WEIM footprint for each BAAs <ul style="list-style-type: none"> • Imbalance, GHG allocate to EDAM entity and ISO measured demand • Add RT system offset apply to WEIM area consider FMM RTD 	Core	Settlements
EDAM-BRQ-19289	UFE Settlements election process shall apply to EDAM BAA as well as WEIM BAAs	Existing	Settlements
EDAM-BRQ-19290	RTM Settlements: Reversal (liquidation) settle at FMM LMP for CB EDAM resource DAM awards Same as for CAISO: Supply/Demand awards for virtual resources will be reversal (demand/Supply) settled in FMM LMP for EDAM resource with CB awards	Core	Settlements
EDAM-BRQ-19291	RTM Settlements: RUC BCR for net surplus/shortfall for EDAM	Core	Settlements

 California ISO	Technology	Template Version:	6.8
		Document Version:	6.1.7
Extended Day Ahead Market Business Requirements Specification - Planning		Date Created:	1/21/2026

ID#	Business Feature	Requirement Type	Potential Application(s) Impacted
	For each EDAM BAA, calculate RUC surplus/shortfall for each resource that awarded RCU/RCD <ul style="list-style-type: none"> • Calculate Res RUC Revenue (RCU/RCD payment less no-pay) <ul style="list-style-type: none"> ○ RCU award at RCU price less no-pay ○ RCD award at RCD less no pay ○ Sum them together • Calculate Res RUC Cost (RCU/RCD commitment and Bid Cost for the RUC award less no-pay amount) <ul style="list-style-type: none"> ○ RCU commitment cost less no-pay ○ RCD commitment cost less no-pay ○ Sum them together • Net RUC revenue and cost, determine surplus/shortfall 		
EDAM-BRQ-19293	RTM Settlements: RTM BCR for net surplus/shortfall for EDAM BAA <ul style="list-style-type: none"> • Res RTM Revenue (IIE, AS, FRP GHG Settlements) • Res RTM Costs include (SUC, MLC, TC, IIE bid cost, AS bid cost) • Sum them together • Net the RTM revenue and cost, determine surplus/shortfall 	Core	Settlements
EDAM-BRQ-19294	EDAM BAA will have BCR sequential netting apply between RUC surplus/RTM shortfall, as well as RUC shortfall/RTM surplus <ul style="list-style-type: none"> • The value of sequential netting RUC revenue and RUC cost, RTM revenue and RTM cost Res, daily revenue not cover the cost is eligible for RTM BCR • EIM sequential netting of RUC and RTM Bid Cost Uplift • Within each EIM BAA, do sequential netting of RUC and RTM Bid Cost Uplift similar to CAISO BAA 	Core	Settlements
EDAM-BRQ-19295	RUC BCR allocation adjusted for net transfer	Core	Settlements

 California ISO	Technology	Template Version:	6.8
		Document Version:	6.1.7
Extended Day Ahead Market Business Requirements Specification - Planning		Date Created:	1/21/2026

ID#	Business Feature	Requirement Type	Potential Application(s) Impacted
	<p>After sequential netting, the RUC BCR adjustment shall apply:</p> <ul style="list-style-type: none"> • Apply RUC transfer adjustment to RUC BCR <ul style="list-style-type: none"> ○ RUC BCR adjustment = Total BAA RUC BCR Amount * (Reliability Capacity Net transfer out / sum of (Reliability Capacity (RC) Net transfer out + measured demand) ○ RUC BCR Adjustment distribution = RUC BCR Adjustment * BAA Reliability Capacity Net Reliability Capacity Transfer In / (Total of all BAA net Reliability Capacity Transfer In) • For EDAM BAA, RUC BCR costs shall be allocated to entity • For ISO, RUC BCR in alignment with RCU cost allocation, to net virtual supply and under scheduled load -DAME <p>Note: RUC RC net transfer quantity equal to RC up less RC down, to determine the net transfer out/in</p>		
EDAM-BRQ-19296	<p>HASP reversal shall apply to EDAM BAA IFM intertie schedule</p> <ul style="list-style-type: none"> • Same as ISO, EDAM BAA's Intertie schedules awarded an energy schedule in the day-ahead market that subsequently have an incremental/decremental FMM schedule change in the RTM and did not submit an energy profile tag prior to HASP, will be subject to the HASP reversal rule applied through settlements <p>Note: HASP reversal does not apply to transfers</p>	Core	Settlements
EDAM-BRQ-19297	<p>Implementation fee</p> <ul style="list-style-type: none"> • The CAISO will recover the cost to implement each EDAM Entity, which may vary depending on the size and complexity of the project • A \$300,000 deposit will be collected from prospective EDAM Entities to cover the actual start-up costs incurred. If the deposit exceeds the actual cost incurred to provide onboarding services, the CAISO will refund the excess 	Process	Finance

 California ISO	Technology	Template Version:	6.8
		Document Version:	6.1.7
Extended Day Ahead Market Business Requirements Specification - Planning		Date Created:	1/21/2026

ID#	Business Feature	Requirement Type	Potential Application(s) Impacted
	<p>amount, including any Interest accrued on the remaining deposit</p> <ul style="list-style-type: none"> • If the actual implementation costs exceed the deposit, additional deposits in \$300,000 increments will be required, which the EDAM Entity must pay within thirty (30) days of receiving the invoice. Any invoice payment past due will accrue interest 		
EDAM-BRQ-19298	<p>Update Grid Management Charge (GMC)</p> <ul style="list-style-type: none"> • Split current System Operations GMC into: <ul style="list-style-type: none"> ○ System Operations Real-Time Dispatch (SYSOPRTD): Represents the fees for real-time dispatch services for EDAM and CAISO BAA and applies to metered flows in MWh of supply and demand <ul style="list-style-type: none"> ▪ Applies to EDAM and CAISO BAA ▪ For WEIM only: The WEIM GMC System Operation Component will continue to settle at the current WEIM GMC System Operations Component (ESYSOPR) rate. The ESYOPR rate shall be equal to the SYSOPRTD rate ○ System Operations Balancing Authority Area Services (SYSOPBAA-details provided in the DAME BRS) <ul style="list-style-type: none"> ▪ Applies to CAISO BAA only • Develop new Extended Day-Ahead Market (EDAM) Transitional Load Ramp-in Mechanism to apply to both the Market Services GMC and SYSOPRTD: <ul style="list-style-type: none"> ○ Four-year increasing rate structure effective at the activation of EDAM applicable to EDAM SCs for Load: <ul style="list-style-type: none"> ▪ Charge 5% of the applicable charges in 2026 (1st operational year of EDAM), 25% in 2027, 50% in 2028, 75% in 2029, and 100% in 2030 • Market Services GMC: Existing market service represents fees for the real-time market and the day-ahead market services shall be extended to EDAM and applied to awarded MWh of energy and MW of capacity 	Core	Settlements

 California ISO	Technology	Template Version:	6.8
		Document Version:	6.1.7
Extended Day Ahead Market Business Requirements Specification - Planning		Date Created:	1/21/2026

ID#	Business Feature	Requirement Type	Potential Application(s) Impacted
	<ul style="list-style-type: none"> ○ Replaces the need for an EDAM Administrative charge code ● TOR/ETC GMC fee does not apply to EDAM, only apply as today. EDAM TOR/ETC will be treated as normal resource. <p>Note: For more details regarding the GMC, see the 2023 Cost-of-Service Study</p>		
EDAM-BRQ-19300	<p>EDAM entity shall provide each EDAM BAA’s next year annual recoverable revenue forecast and components to CAISO:</p> <ul style="list-style-type: none"> ● EDAM Entities will provide next year forecasts for the aggregate EDAM transmission Recoverable Revenue and it’s three components: <ul style="list-style-type: none"> ○ Forecast of Aggregate EDAM Recoverable Revenue (\$) ○ Component 1: Short-Term Firm and Non-Firm Point-to-Point Transmission forecasted annual Recoverable Revenue (\$) ○ Component 2: New Transmission Capacity forecasted annual Recoverable Revenue (\$) ○ Component 3: Transmission Costs Associated With EDAM Wheeling Through Transfer Volumes Net of Imports/Exports forecasted annual Recoverable Revenue (\$) <p>Note: EDAM Recoverable Revenue is the expected revenue shortfall due to EDAM participation compared with historical average prior to EDAM. Actual true-up will be added to the next year’s recoverable revenue. EDAM Recoverable Revenue recovered through EDAM Access Charge</p>	Process	CIDI
EDAM-BRQ-19301	<p>EDAM entity shall provide EDAM Recoverable Revenue true-up amount for the following year</p> <ul style="list-style-type: none"> ● Each EDAM Entity shall provide EDAM Recoverable Revenue true-up amount for the following year (\$) <p>Note: The CAISO will include a true-up amount, positive or negative; to balance the difference between the CAISO’s</p>	Process	CIDI

 California ISO	Technology	Template Version:	6.8
		Document Version:	4.6 1.7
Extended Day Ahead Market Business Requirements Specification - Planning		Date Created:	1/21/2026

ID#	Business Feature	Requirement Type	Potential Application(s) Impacted
	projected EDAM Access Charge collections and actual collections for each EDAM Transmission Service Provider.		
EDAM-BRQ-19302	<p>For the initial year of an EDAM entity’s entry into EDAM, EDAM entity shall provide supporting information for recoverable revenue calculation to CAISO</p> <ul style="list-style-type: none"> ○ Submissions are due to the CAISO by July 1st to determine the EDAM Access Charge for the following year ○ At a minimum EDAM Entities must provide: <ul style="list-style-type: none"> ○ The final order from FERC or the Local Regulatory Authority effecting their approved transmission rates (\$/MWh) and any informational filings or postings under relevant formula rates; ○ The sums for each EDAM Recoverable Revenue component and true-up; and ○ An authorized affidavit from each EDAM Transmission Service Provider attesting to the accuracy of the data provided and that the EDAM Transmission Service will make reasonable efforts to avoid any double recovery of costs through the EDAM Access Charge. ○ All data provided must be sufficiently granular to enable verification of the EDAM Access Charge rates by the CAISO and Market Participants. 	Process	CIDI
EDAM-BRQ-19305	<p>Consume yearly EDAM BAA EDAM Access Charge Revenue Recovery plus any prior year true-up</p> <p>Consume entity submitted Revenue Recovery in \$ annually:</p> <ul style="list-style-type: none"> • EDAM entity and ISO PTO* shall submit annually Revenue Recovery in \$ • EDAM entity and ISO PTO* shall submit component 1, component 2 and component 3 in \$ • Use same method (CIDI) as for entity Transmission Access Cost (TAC) submission • Customer shall submit other elements: True-up value \$), bounded cap (\$), Transmission rates (\$/MWh), ratio (%) and the calculation (new template-see Business Process) <p>Notes:</p>	Core	Settlements Manual Process

 California ISO	Technology	Template Version:	6.8
		Document Version:	4.6 1.7
Extended Day Ahead Market Business Requirements Specification - Planning		Date Created:	1/21/2026

ID#	Business Feature	Requirement Type	Potential Application(s) Impacted
	Requirements for ISO PTO submission are covered in the CAISO BAA EDAM Participation Rules Initiative See Appendix A8 for the EDAM Access Charge Illustrative Example		
EDAM-BRQ-19310	<p>Calculate EDAM Recoverable Revenue: Component 1 – Short-Term Firm and Non-Firm Point-to-Point Transmission</p> <ul style="list-style-type: none"> • Calculate Component 1 reference baseline as prior three years average • EDAM entity shall calculate the annual average revenue of transmission sales to third parties from eligible transmission sales of prior three years at time of EDAM activation. <ul style="list-style-type: none"> ○ Eligible transmission sales include monthly, weekly, daily and hourly sales of firm/non-firm point to point Transmission services to third parties ○ The three years average will be fixed in the calculation of next year’s recoverable revenue <ul style="list-style-type: none"> ▪ Exception: when additional adjacent BAAs join the EDAM, and new recoverable revenue is added to the calculation <p>Ex: BAA 1: \$14,242,500</p> <p>Note: See Appendix A8 for the EDAM Access Charge Illustrative Example (Tables 1 and 2)</p>	Core	EDAM Entity Calculation
EDAM-BRQ-19310a	<p>Component 1 – Revenue Shortfall Forecast</p> <p>EDAM entity shall forecast the next years expected Component 1 of EDAM Recoverable Revenue that is the revenue the entity will forgo as a result of EDAM participation.</p> <ul style="list-style-type: none"> • The EDAM Transmission Service Provider will include only that portion of revenues from the three-year average that the EDAM Transmission Service Provider reasonably expects to forgo as a result of participating in the EDAM • Ex: BAA1: \$7,121,250 (see table 2) 	Core	EDAM Entity Calculation

 California ISO	Technology	Template Version:	6.8
		Document Version:	6.1.7 1.7
Extended Day Ahead Market Business Requirements Specification - Planning		Date Created:	1/21/2026

ID#	Business Feature	Requirement Type	Potential Application(s) Impacted
EDAM-BRQ-19310b	<p>Component 1 annual true-up</p> <ul style="list-style-type: none"> The actual shortfall/surplus will be the difference between the EDAM Transmission Service Provider's actual sales of qualifying products for the applicable calendar year compared to the fixed three-year pre-EDAM average. <p>True-up amount (positive or negative) will be its actual shortfall/surplus in lieu of the forecasted shortfall/surplus.</p>	Core	EDAM Entity Calculation
EDAM-BRQ-19310c	<p>Component 1 recoverable revenue limits</p> <p>Component 1 EDAM Recoverable Revenue for each EDAM Entity will be capped at the product of (a) its total eligible OATT or WACC sales and (b) the percentage resulting from dividing exports from its EDAM Balancing Authority Area to the EDAM Area by total exports from the EDAM Balancing Authority Area.</p> <ul style="list-style-type: none"> Exports: sum of hourly of the prior year. If all intertie exports are EDAM transfers, the ratio is 1 <ul style="list-style-type: none"> Transfer export: exports from its EDAM Balancing Authority Area to the EDAM Area. Ex: 6,000 MWh Non-transfer export: exports from its EDAM Balancing Authority Area to the non-EDAM Area. Ex: 4,000 MWh Total export: Transfer export plus non-transfer export. Ex: 10,000 MWh The percentage: Transfer export/total export: 60% Projected Component 1 Recoverable Revenue for each EDAM Entity is before true-up that is based on three years average forecast (BAA1 \$14,242,500, table 1 in example) <p>Note: Limit is calculated by EDAM entity EX: BAA1: $\\$14,242,500 * 6000 / 10000 = \\$8,545,500$ Because $\\$7,121,250 < \\$8,545,500$, so the amount is accepted</p>	Core	EDAM Entity Calculation
EDAM-BRQ-19320	<p>ISO to calculate EDAM Access Charge Revenue Recovery for CAISO—use the prior three years of information as per ISO BAA rules</p>	Process	Settlements

 California ISO	Technology	Template Version:	6.8
		Document Version:	4.6 1.7
Extended Day Ahead Market Business Requirements Specification - Planning		Date Created:	1/21/2026

ID#	Business Feature	Requirement Type	Potential Application(s) Impacted
	Note: Refer to the ISO EDAM Participation Rules Initiative for details	PTO calculate and submit to ISO, WAC by intertie	
EDAM-BRQ-19330	Component 2 – New transmission Capacity Calculate component 2 ratio <ul style="list-style-type: none"> ○ The ratio of (a) the non-firm and short-term firm point-to-point historical EDAM recoverable transmission revenues from the pre-EDAM three-year average in component 1 to (b) the EDAM Entity's annual average revenue requirement over the same three years. EX: BAA1 (a) \$14,242,500, (b)\$158,250,000, (a)/(b) =9% Table 3	Core	EDAM entity calculation
EDAM-BRQ-19330a	Component 2 – New transmission Capacity Eligible Component 2 costs include <ul style="list-style-type: none"> ○ Forecasted foregone short term revenue from expired legacy contracts: ○ EDAM entity will include reduced revenues from sales of non-firm and short-term firm transmission associated with the release of transmission capacity resulting from the expiration of EDAM Legacy Contracts that not included in Component 1. ○ The EDAM entity calculation shall observe the following rules: ○ The forecasted forgone revenue should be not exceed the product of the most recent annual revenue of the expired EDAM Legacy Contract multiplied by the Component 2 ratio (described in BRQ-19330) Note: See Appendix A8 for the EDAM Access Charge Illustrative Example (Tables 3 and 4)	Core	EDAM entity calculation
EDAM-BRQ-19330b	Eligible Component 2 costs include: <ul style="list-style-type: none"> ○ Forecasted foregone short term revenue sales associated with new network upgrades: 	Core	EDAM entity calculation

 California ISO	Technology	Template Version:	6.8
		Document Version:	6.1.7
Extended Day Ahead Market Business Requirements Specification - Planning		Date Created:	1/21/2026

ID#	Business Feature	Requirement Type	Potential Application(s) Impacted
	<ul style="list-style-type: none"> ○ EDAM entity will include the forecasted foregone revenue from eligible new network upgrades. ○ The EDAM entity calculation shall observe the following rules: ○ Eligible network upgrades must be a. in service, b. rate recovery approved by LRA or FERC; c. increase transfer capability between EDAM BAAs; d. are energized in EDAM. ○ Proxy baseline: The baseline will be the product of Component 2 ratio and the transmission revenue requirement for the new network upgrade ○ The forecasted foregone revenue shall not exceed the proxy baseline <p>EX: BAA3: Annual TRR \$11,000,000, Forecast short term sales= \$11,000,000*2.17%=\$238,700 Out of \$238,700, Projected Shortfall \$59,000, accepted</p>		
EDAM-BRQ-19330c	<p>Component 2 annual update of foregone revenue based upon actual sales</p> <ul style="list-style-type: none"> ○ The EDAM Transmission Service Provider will replace projected forgone revenues with actual forgone revenues in the following year's Component 2 EDAM Recoverable Revenue based on the proxy baseline. ○ Actual forgone revenue: point to point sales of new upgrades based upon year 1 of the transmissions' energization <p>Ex: BAA3 projected component 2 based on proxy baseline is \$59,000 in year 1; Actual is \$61,000 in year 1, for the following year 2, projected foregone component 2 is \$61,000</p> <ul style="list-style-type: none"> ○ For EDAM BPM : The CAISO will include examples of network upgrades that increase transfer capability for purposes of this Section and examples that do not do so in the Business Practice Manual for the Extended Day-Ahead Market. For purposes of this section, network upgrades will be deemed to increase transfer capability where they: <ul style="list-style-type: none"> (a) increase total transfer capability; (b) create new interfaces; 	Core	EDAM entity calculation

 California ISO	Technology	Template Version:	6.8
		Document Version:	6.1.7
Extended Day Ahead Market Business Requirements Specification - Planning		Date Created:	1/21/2026

ID#	Business Feature	Requirement Type	Potential Application(s) Impacted
	<ul style="list-style-type: none"> (c) increase the simultaneous import limits at existing interfaces; (d) result from an Interregional Transmission Project to increase transfer capability; or (e) were identified through the WECC path rating process as increasing total transfer capability or creating new transmission interfaces; <p>Between EDAM Entity Balancing Authority Areas or between the CAISO Balancing Authority Area and an EDAM Entity Balancing Authority Area.</p>		
EDAM-BRQ-19340a	<p>Component 3 – Revenues from Wheeling-Through Transfers Exceeding the TSPs Imports and Exports</p> <p>Component 3 – step 1 Calculate monthly Volume MWh</p> <ul style="list-style-type: none"> • Calculate total volume of wheeling-through transactions in excess of the total net transfers (imports and exports) of the applicable EDAM BAAs, as measured on a monthly basis. • Provide monthly volume to EDAM entity in settlement statement supporting information in BAA Bill determinant file • The calculation is for both EDAM entity and ISO. <p>Ex: BAA1 net incremental wheeling through transfer volume: 10,000 MWh</p>	Core	Settlements
EDAM-BRQ-19340b	<p>Component 3 – step 2 calculate monthly revenue based on volume and transmission rate</p> <ul style="list-style-type: none"> • Calculate revenue based on MWh on step 1 by the applicable EDAM Transmission Service Provider’s non-firm hourly point-to-point transmission rate*. For Participating TOs, the CAISO will use the applicable Wheeling Access Charge rate. • The calculation is for both EDAM entity and ISO on monthly basis • CAISO provide EDAM entity in settlement statement supporting information in BAA Bill determinate file <p>Notes:</p>	Core	Settlements

 California ISO	Technology	Template Version:	6.8
		Document Version:	6.1.7
Extended Day Ahead Market Business Requirements Specification - Planning		Date Created:	1/21/2026

ID#	Business Feature	Requirement Type	Potential Application(s) Impacted
	<ul style="list-style-type: none"> *Each EDAM Entity to provide to CAISO the TSP's non-firm hourly point-to-point transmission rate For the ISO BAA, this rate is equal to the WAC rate Ex: submitted transmission rate \$5/MWh by EDAM entity, Revenue = 10,000 MWh *\$5/MWh =\$50,000		
EDAM-BRQ-19340c	<p>Component 3 – step 3 calculate and submit annual recoverable revenue</p> <ul style="list-style-type: none"> EDAM entity shall calculate annual Revenues from Wheeling-Through Transfers Exceeding the TSPs Imports and Exports based on monthly amount received from ISO in step 2 (BRQ-19340b) Submit to CAISO as component 3 annual revenue shortfall associated with wheeling-through Note: See Appendix A8 for the EDAM Access Charge Illustrative Example (Table 5)	Core	EDAM Entity Calculation
EDAM-BRQ-19350a	<p>EDAM Access Charge Assessment:</p> <p>Step 1 - Distribute the EDAM BAA recoverable revenue</p> <ul style="list-style-type: none"> For each EDAM BAA recoverable revenue, Settlements shall distribute each BAA's recoverable revenue (sum of components and true-ups) to the other EDAM BAAs in proportion to their BAA gross load. Note: Exclude the gross load of each BAA. E.g., BAA1 recoverable revenue will be distributed to total BAA gross load, excluding BAA1 gross load. <p>Ex: Distribute BAA1 recoverable revenue \$7,121,250 to BAA2, BAA3 and BAA4, as \$577,054 \$2,575,810 \$3,968,386 based on each BAA load (BAA2:15,850,000 BAA3: 70,750,000 BAA4:109,000,000) proportion to the gross load (195,600,000) that not include BAA1 load (35,800,000)</p> Note: See Appendix A8 for the EDAM Access Charge Illustrative Example (Table 6 and 7)	Core	Settlements
EDAM-BRQ-19350b	<p>EDAM Access Charge Assessment:</p> <p>Step 2 - Calculate the total distributed cost for each BAA as the sum of the distributed costs from other BAAs</p> Note: For reporting purposes	Core	Settlements

 California ISO	Technology	Template Version:	6.8
		Document Version:	6.1.7
Extended Day Ahead Market Business Requirements Specification - Planning		Date Created:	1/21/2026

ID#	Business Feature	Requirement Type	Potential Application(s) Impacted
	<p>Ex: for BAA1 sum of distributed costs from BAA2, BAA3, BAA4 (\$185,353 \$264,628 \$472,361), total is \$922,342</p> <p>Note: See Appendix A8 for the EDAM Access Charge Illustrative Example (Table 6 and 7)</p>		
EDAM-BRQ-19350c	<p>EDAM Access Charge Assessment: Step 3 - Calculate BAA-specific EDAM Access Charge Rate (\$/MWh) based on gross load</p> <ul style="list-style-type: none"> • Calculate the total EDAM Access Charge cost distribution to each BAA divided by the BAA gross load • Calculate the BAA EDAM Access Charge rate by BAA distribution components <ul style="list-style-type: none"> ○ Each BAA EDAM Access Charge rate by distribution shall be calculated by dividing each BAA's distributed recoverable costs from other EDAM BAAs by the BAA gross load <p>Ex: for BAA1 total cost allocation is \$922,342, gross load 35,800,000, access charge rate = \$922,342/35,800,000 MWh = \$0.026/MWh</p> <p>BAA1 for BAA2: (\$185,353/35,800,000 MWh) = \$0.005/MWh</p> <p>BAA1 for BAA3: (\$264,628/35,800,000 MWh) = \$0.008/MWh</p> <p>BAA1 for BAA4: (\$472,361/MWh 35,800,000) = \$0.013/MWh</p> <p>Sum of each component: (0.005+0.008+0.013) = \$0.026/MWh</p> <p>Note: See Appendix A8 for the EDAM Access Charge Illustrative Example (Table 8)</p>	Core	Settlements
EDAM-BRQ-19360	<p>Collection of EDAM Access Charges: Apply EDAM Access Charge Rate to Actual Gross Load and Settle on Monthly Basis</p> <ul style="list-style-type: none"> • Apply the EDAM BAA Access Charge distribution rates to the current year actual gross load • Settle on a monthly basis <p>Ex: BAA1 actual gross load 36,740,463MWh, For BAA1 in reference to BAA2 (rate=\$0.005/MWh), BAA3 (rate=\$0.008/MWh), and BAA4 (rate=\$0.005/MWh) distributions, rate=\$0.013/MWh, collect EDAM access charge from BAA1: (36,740,463MWh*\$0.005/MWh) +</p>	Core	Settlements

 California ISO	Technology	Template Version:	6.8
		Document Version:	6.1.7
Extended Day Ahead Market Business Requirements Specification - Planning		Date Created:	1/21/2026

ID#	Business Feature	Requirement Type	Potential Application(s) Impacted
	$(36,740,463\text{MWh} * \$0.008/\text{MWh}) + (36,740,463\text{MWh} * \$0.013/\text{MWh}) = \$955,252.038/\text{MWh}$ Note: See Appendix A8 for the EDAM Access Charge Illustrative Example (Table 9)		
EDAM-BRQ-19361	<p>Distribution of EDAM Access Charge Collected Revenues</p> <ul style="list-style-type: none"> • Distribute BAA-specific EDAM Access Charge revenue in proportion to each EDAM Entity's share of total projected EDAM Recoverable Revenue. • The BAA total EDAM access charge revenue is the sum of distributed revenue from other BAAs <ul style="list-style-type: none"> ○ System shall distribute an EDAM BAAs Access Charge from those BAAs gross load for which the BAA recoverable revenue was collected for, based upon the following rates: for each BAA use the EDAM Access charge rate by distributed recovery cost, as calculated in BRQ19350c. <p>Ex: for BAA1 sum of allocated costs from BAA2, BAA3, BAA4 (\$185,353 \$264,628 \$472,361), total projected cost is \$922,342, proportion share for BAA2, BAA3, BAA4 is around 0.201, 0.287, 0.512. (Table 7)</p> <p>The actual BAA1 access charge collection is \$950,000 (table 9), use the same share, the BAA2,BAA3,BAA4 distributed revenue is \$190,820, \$271,622, \$487,558 (table 10)</p> <p>The BAA1 total revenue is the sum of BAA2,BAA3, BAA4 distributed revenue to BAA1 (\$565,942 \$2,630,637 \$3,875,095) , total is \$7,071,674 (table 10)</p> <p>Note: See Appendix A8 for the EDAM Access Charge Illustrative Example (Table 10)</p>	Core	Settlements
EDAM-BRQ-19362	<p>Annual true-up for Recoverable Revenue</p> <ul style="list-style-type: none"> • Calculate the total true-up amount of recoverable EDAM revenues: difference of actual OATT short-term sales plus the collected revenue (table 10) and historical 3 years average of short-term sales. • For EDAM BAAs, the EDAM entity shall submit the true-up to ISO per the new EDAM Access Charge template 	Core	EDAM entity calculation

 California ISO	Technology	Template Version:	6.8
		Document Version:	4.6 1.7
Extended Day Ahead Market Business Requirements Specification - Planning		Date Created:	1/21/2026

ID#	Business Feature	Requirement Type	Potential Application(s) Impacted
	<ul style="list-style-type: none"> For CISO BAA, see CAISO EDAM BAA Participation Rules Initiative The EDAM Access Charge Revenue Recovery will include true-up adjustments for the following year Note: See Appendix A8 for the EDAM Access Charge Illustrative Example (Table 11)		
EDAM-BRQ-19364	Publish Revenue Recovery Public Values <ul style="list-style-type: none"> Publish publicly (ISO Website under Settlements): <ul style="list-style-type: none"> For each EDAM Transmission Service Provider: the current sum of each recoverable revenue component, the total true-up, and total eligible recovery amount For each EDAM BAA: the EDAM Access Charge, including the rate, the Gross Load, and the total eligible recovery amount 	Core <u>Process</u>	Settlements CAISO.com
EDAM-BRQ-19365	Publish performance report no later than three years after EDAM access charge effective date <ul style="list-style-type: none"> No later than three (3) years after the original effective date, CAISO shall publish a performance report. The performance report will include without limitation: an explanation of the impacts of the EDAM Access Charge on EDAM Transmission Service Providers' revenue recovery and rates; the performance of the EDAM Access Charge in managing cost shifts among customers; and analysis by the CAISO of any other impacts or externalities	Core <u>Process</u>	CAISO.com
EDAM-BRQ-19370	Flexible Ramp Forecasted Movement Settlements <ul style="list-style-type: none"> The system shall calculate FRU and FRD FMM forecasted movement as a deviation Settlements from DA forecasted movement The system shall calculate FRU and FRD RTD forecasted movement as a deviation Settlements from FMM forecasted movement 	Core	Settlements
EDAM-BRQ-19380	Flexible Ramp Forecasted Movement Allocation <ul style="list-style-type: none"> System shall allocate FRU and FRD FMM and RTD forecasted movement Settlements to the pass group, or BAAs or pool that fail: 	Core	Settlements

 California ISO	Technology	Template Version:	6.8
		Document Version:	6.1.7
Extended Day Ahead Market Business Requirements Specification - Planning		Date Created:	1/21/2026

ID#	Business Feature	Requirement Type	Potential Application(s) Impacted
	<ul style="list-style-type: none"> ○ For BAAs that fail WEIM RSE, allocate to WEIM BAA that failed EDAM AET sub-pool, and EDAM RSE non-AET sub-pool based upon pro-rata metered load of those pools or BAAs 		
EDAM-BRQ-19390	Uncertainty Up Settlements <ul style="list-style-type: none"> ● The system shall settle FMM FRU awards as a deviation Settlements from the 5-minute ramp capable imbalance reserve award at the FMM FRU price ● The system shall settle RTD FRU awards as a deviation Settlements from the FMM FRU awards at the RTD FRU price 	Core	Settlements
EDAM-BRQ-19400	Uncertainty Up Allocation <p>The system shall allocate the total RTM FRU uncertainty cost through the two-tier allocation methodology based upon the FRU pass group, or BAAs/pool that fail</p> <ul style="list-style-type: none"> ○ If the EDAM Pool fails the WEIM RSE test, the BAAs associated with the EDAM pool will create two sub-groups based on their AET elections (AET and non-AET). ○ WEIM-only BAAs that fail the WEIM RSE will be assessed as standalone BAAs. ○ The WEIM BAAs and EDAM Pool that pass the WEIM RSE shall be grouped together in the FRU pass group. 	Core	Settlements
EDAM-BRQ-19410	Uncertainty Down Settlements <ul style="list-style-type: none"> ● The system shall settle FMM flexible ramp uncertainty awards as a deviation Settlements from the 5-minute ramp capable imbalance reserve award at the FMM FRD price ● The system shall settle RTD flexible ramp uncertainty awards as a deviation Settlements from the FMM FRD awards at the RTD FRD price 	Core	Settlements
EDAM-BRQ-19420	Uncertainty Down Allocation <ul style="list-style-type: none"> ● The system shall allocate the total RTM FRD uncertainty cost through the two-tier allocation 	Core	Settlements

 California ISO	Technology	Template Version:	6.8
		Document Version:	6.1.7
Extended Day Ahead Market Business Requirements Specification - Planning		Date Created:	1/21/2026

ID#	Business Feature	Requirement Type	Potential Application(s) Impacted
	methodology based upon the FRD pass group, or BAA/pool that failed <ul style="list-style-type: none"> ○ The EDAM Pool that fails the WEIM Downward RSE test shall settle as an EDAM BAA group 		
EDAM-BRQ-19430	Settlements With regard to the CAISO's assessment and payment of charges to, and collection of charges from, EDAM Market Participants pursuant to Sections 11 and 33.11, and 29.11, the CAISO will assess, pay, and collect such charges, address disputed invoices, assess, pay and collect Settlements-related fees and charges, including those under Sections 11.21, 11.28, and 11.29, and make any financial adjustments in accordance with the terms and schedule set forth in Section 11 <ul style="list-style-type: none"> • Settlements shall publish trade day statement, invoice, and support data automatically 	Existing Process	Settlements
EDAM-BRQ-19440	Creditworthiness EDAM Entity Scheduling Coordinators, EDAM Load Serving Entity Scheduling Coordinators, and EDAM Resource Scheduling Coordinators must comply with the creditworthiness requirements of the CAISO Tariff. In the event EDAM Entity Scheduling Coordinators, EDAM Load Serving Entity Scheduling Coordinators, or EDAM Resource Scheduling Coordinators fail to satisfy the credit or other requirements in Section 12, the consequences specified in Section 12 will apply.	Process	Finance
EDAM-BRQ-19450	Dispute Resolution Confirmation and validation of any dispute associated with the participation of EDAM Market Participants in the Day-Ahead Market is subject to Section 11.29.8 and will be managed through the CAISO's customer inquiry, dispute, and information system and as provided in the Business Practice Manual for the Extended Day-Ahead Market. EDAM Market Participants will be subject to dispute resolution pursuant to Section 13	Existing Process	Settlements
EDAM-BRQ-19460	FRP Monthly Resettlement Up Allocations	Existing Process	Settlements

 California ISO	Technology	Template Version:	6.8
		Document Version:	6.1.7
Extended Day Ahead Market Business Requirements Specification - Planning		Date Created:	1/21/2026

ID#	Business Feature	Requirement Type	Potential Application(s) Impacted
EDAM-BRQ-19470	Monthly Resettlement Down Allocations	Existing Process	Settlements
EDAM-BRQ-19480	Calculate IR congestion revenue Calculate congestion revenue for supply as product of the award of IR and IR MCC of LMP by BAA Calculate the aggregated IR adjusted requirement on aggregated MCC of IRMP (IR requirement less the demand curve adjustment) <ul style="list-style-type: none"> • IRUR/IRDR by BAA • IRUS/IRDS by BAA • Deployment factor by IRU/IRD • Aggregate IRUMP/IRDMP (all the location of IRUR/IRDR allocated) and components by BAA (MP of IR and MCC for IR congestion, no loss and no GHG) 	Core	Settlements
EDAM-BRQ-19490	Force Majeure, Indemnity, Liabilities, and Penalties The provisions of Section 14 regarding Uncontrollable Force, indemnity, liability, and penalties will apply to the participation of EDAM Market Participants in the Day-Ahead Market	Existing Process	Settlements
EDAM-BRQ-19500	Good faith negotiations (neutrality): The CAISO shall be authorized to levy additional charges or make additional payments as special adjustments in regard to: Amounts required to reach an accounting trial balance of zero in the course of the Settlement process in the event that the charges calculated as due from CAISO Debtors are lower than payments calculated as due to the CAISO Creditors for the same TD Awards payable by or to the CAISO pursuant to good faith negotiations or CAISO ADR Procedures that the CAISO is not able to allocate to or to collect from a MP in accordance with Tariff Section 13.5.3 See Tariff Section 11.14 for further details	Process	Settlements

 California ISO	Technology	Template Version:	6.8
		Document Version:	4.61.7
Extended Day Ahead Market Business Requirements Specification - Planning		Date Created:	1/21/2026

ID#	Business Feature	Requirement Type	Potential Application(s) Impacted
EDAM-BRQ-19510	<p>Consume the market clearing results for EDAM resource AS self-provision and associated AS price</p> <ul style="list-style-type: none"> Hourly DA EDAM Resource Advisory AS Price Hourly DA EDAM Resource AS Self Provisions <p>This shall apply to all AS products, including:</p> <ul style="list-style-type: none"> Spin Non-Spin Regulation Up Regulation Down 	Existing	Settlements
EDAM-BRQ-19520	<p>Publish the EDAM BAA resource AS self-provision and AS advisory price</p> <p>For the non-CAISO EDAM BAA</p> <ul style="list-style-type: none"> Bypass AS settlement calculation for (non-CAISO) EDAM resources. AS settlement shall only be calculated for CAISO resources Include resource AS self-provision MW and AS advisory price in BD file Allow EDAM entity to access resource AS advisory price and self-provision AS schedule report 	Core	Settlements
EDAM-BRQ-19530	<p>Ensure EDAM resource AS advisory price not impacting ISO and WEIM settlement</p> <ul style="list-style-type: none"> System shall be configured so that non-CAISO EDAM AS self-provision and advisory price results shall not impact CISO BAA nor RTM/EIM pre-calculations and CCs. 	Core	Settlements
EDAM-IST-BRQ-19540	<p>Day-ahead Inter-SC Trade Settlement</p> <ul style="list-style-type: none"> Settlement for From SC as product of the IST DA quality from SC and trade location LMP Settlement for To SC as product of (-1) *the IST DA quality To SC and trade location LMP 	Existing	Settlements

 California ISO	Technology	Template Version:	6.8
		Document Version:	6.1.7 1.7
Extended Day Ahead Market Business Requirements Specification - Planning		Date Created:	1/21/2026

ID#	Business Feature	Requirement Type	Potential Application(s) Impacted
EDAM-IST-BRQ-19550	<p style="color: red;">FMM Inter-SC Trade Settlement</p> <ul style="list-style-type: none"> • Settlement for From SC as product of the IST hourly quality from SC and trade location average FMM LMP • Settlement for To SC as product of (-1) *the IST hourly quality To SC and trade location average FMM LMP 	Existing	Settlements
EDAM-TSR-BRQ-19617	<p>CRN Balancing Rules by CRN by BAA</p> <ul style="list-style-type: none"> • The system shall validate, for each CRN associated with an ETC or TOR, that self-schedules and meters associated with those self-schedules and CRNs from resources in each BAA are balanced: <ul style="list-style-type: none"> ○ Balanced shall be defined as: the sum of the supply from generating resources, imports, import TSRs etc. is equal to the sum of demand from load, export TSRs, and exports. ○ The unbalanced portion will not have a CRN association, and not receive the financial credit <p>Notes:</p> <ul style="list-style-type: none"> • Applies to DA and RT timeframe • Only applies to ETC/TORs • Include NGRs in the CRN balancing rules 	Core	Settlements
EDAM-TSR-BRQ-19618	<p>CRN Entitlement Validation by CRN by BAA</p> <ul style="list-style-type: none"> • The system shall validate, for each CRN associated with an ETC or TOR, that the sum of the supply self-schedules, i.e., generating resources, imports, import TSRs etc. associated with that CRN from resources in each BAA does not exceed the CRN Entitlement. • The system shall validate, for each CRN associated with an ETC or TOR, that the sum of the demand self-schedules or meter, i.e., load resources, exports, export TSRs etc. associated with that CRN from resources in each BAA does not exceed the CRN Entitlement. <p>Notes:</p> <ul style="list-style-type: none"> • Applies to both DA and RT timeframes 	Core	Settlements

 California ISO	Technology	Template Version:	6.8
		Document Version:	6.1.7 1.7
Extended Day Ahead Market Business Requirements Specification - Planning		Date Created:	1/21/2026

ID#	Business Feature	Requirement Type	Potential Application(s) Impacted
	Treat NGRs as algebraic supply		
EDAM-TSR-BRQ-19620	Settlements No-Pay Rule Updates <ul style="list-style-type: none"> • The system shall calculate the no-pay quantity for Transfer Revenue as the difference between the RT clean bidset award for IR/RC and the DA IR/RC resource awards • The DA Transfer Revenue for IR or RC will be adjusted by the no-pay quantity and the relevant LMP difference between the all relevant TSR pairs at each Transfer Location pair 	Core	Settlements
EDAM-TSR-BRQ-19625	Calculate DA TSR Transfer Revenue for Energy, IRU/IRD and RCU/RCD <ul style="list-style-type: none"> • System shall calculate the hourly DA TSR Transfer Revenue for each TSR for each commodity type as the product of DA TSR transfer schedule times the difference between import and export TSR LMP for each EDAM BAA, including the CISO. • Calculations for the corresponding commodity type: <ul style="list-style-type: none"> ○ Energy: <ul style="list-style-type: none"> ▪ Energy Transfer schedules ▪ EDAM BAA IFM LMP difference between the TSR pairs (import-exports) ○ IRU/IRD <ul style="list-style-type: none"> ▪ IRU/IRD Transfer schedules ▪ EDAM BAA IFM IRU/IRD LMP difference between the TSR pairs (import-exports) ○ RCU/RCD <ul style="list-style-type: none"> ▪ RCU/RCD Transfer schedules ▪ EDAM BAA RUC RCU/RCD LMP difference between the TSR pairs (import-exports) • System shall adjust the DA TSR Transfer Revenue to account for DA Congestion Revenue before distributing as defined in EDAM-TSR-BRQ-19640 and EDAM-TSR-BRQ-19641 	Core	Settlements

 California ISO	Technology	Template Version:	6.8
		Document Version:	6.1.7
Extended Day Ahead Market Business Requirements Specification - Planning		Date Created:	1/21/2026

ID#	Business Feature	Requirement Type	Potential Application(s) Impacted
EDAM-TSR-BRQ-19626	<p>Allocate DA TSR Transfer Revenue for Energy</p> <ul style="list-style-type: none"> For all DA TSRs, the system shall allocate the DA TSR Transfer Revenue per the specified RDF in the Transfer Location definition between the EDAM BAAs on each side of the TSR (including CAISO BAA). The BAA DA Transfer Revenue associated with TSR Type 2 and a TCSC, the system shall directly allocate their portion of the Transfer Revenue to the TCSC. The BAA DA Transfer Revenue associated with a CRN ID "NONE" and TSR Type 2, that portion shall be allocated to the EESC, including CISO SC for the CISO BA The BAA DA Transfer Revenue associated with TSR Types 1, 3, and 4 shall be allocated to the EESC, including CISO SC for the CISO BA, for sub-allocation <p>Notes: For CISO SC sub-allocation, refer to ISO BAA EDAM Participation Rules Initiative</p>	Core	Settlements
EDAM-TSR-BRQ-19627	<p>Allocate DA TSR Transfer Revenue for IRU/IRD and RCU/RCD</p> <ul style="list-style-type: none"> For all DA TSRs, the system shall allocate the DA TSR Transfer Revenue per the specified RDF in the Transfer Location definition between the EDAM BAAs on each side of the TSR (including CAISO BAA). The BAA DA Transfer Revenue associated with TSR Type 2 and a TCSC, the system shall directly allocate their portion of the Transfer Revenue to the TCSC. The BAA DA Transfer Revenue associated with a CRN_ID "NONE" and TSR Type 2, that portion shall be allocated to the EESC, including CISO SC for the CISO BA The BAA DA Transfer Revenue associated with TSR Types 3 and 4 shall be allocated to the EESC, including CISO SC for the CISO BA, for sub-allocation <p>Note: For CISO SC sub-allocation, refer to ISO BAA EDAM Participation Rules Initiative</p>	Core	Settlements

 California ISO	Technology	Template Version:	6.8
		Document Version:	6.1.7
Extended Day Ahead Market Business Requirements Specification - Planning		Date Created:	1/21/2026

ID#	Business Feature	Requirement Type	Potential Application(s) Impacted
EDAM-TSR-BRQ-19630	Calculate DA TSR Congestion Revenue for Energy, IRU/IRD <ul style="list-style-type: none"> • System shall calculate the hourly BAA DA TSR Congestion Revenue for each TSR for each commodity type as the product of DA TSR transfer schedule times the TSR MCC for the corresponding commodity type: <ul style="list-style-type: none"> ○ Energy: BAA Energy Congestion revenue = net of BAA Day Ahead schedules and MCC component of LMP <ul style="list-style-type: none"> ▪ Energy Transfer schedules ▪ EDAM BAA IFM MCC ○ IRU/IRD <ul style="list-style-type: none"> ▪ IRU/IRD Transfer schedules ▪ EDAM BAA IFM IRU/IRD MCC 	Core	Settlements
EDAM-TSR-BRQ-19631	Calculation of DAM Total TSR Congestion Revenue by Commodity type <ul style="list-style-type: none"> • The system shall calculate the DAM total congestion revenue as the sum over each TSR DA congestion revenue 	Core	Settlements
EDAM-TSR-BRQ-19632	Allocate DA TSR Congestion Revenue for Energy by BAA <ul style="list-style-type: none"> • The system shall allocate the DA Energy TSR total congestion revenue to each EDAM BAA based upon the TSR DA schedule times the relevant DA TSR MCC sub-component price associated with each DGAP-TIE and each TRANSFER_LOCATION ID • BAA Energy Congestion Revenue allocation = net of all Day Ahead schedules and MCC sub-component of MCC Component for that BAA 	Core	Settlements
EDAM-TSR-BRQ-19633	Allocate DA TSR Congestion Revenue for IRU/IRD by BAA <ul style="list-style-type: none"> • The system shall allocate the DA IRU/IRD TSR total congestion revenue to each EDAM BAA based upon the TSR DA IRU/IRD schedule times the relevant DA TSR IRU/IRD MCC sub-component price associated with each DGAP-TIE and each TRANSFER_LOCATION ID 	Core	Settlements

 California ISO	Technology	Template Version:	6.8
		Document Version:	6.8 1.7
Extended Day Ahead Market Business Requirements Specification - Planning		Date Created:	1/21/2026

ID#	Business Feature	Requirement Type	Potential Application(s) Impacted
	Note: RCU/RCD is already captured as part of allocation		
EDAM-TSR-BRQ-19635	Calculate RTM TSR Transfer Revenue for DA TSRs <ul style="list-style-type: none"> System shall calculate the FMM TSR Transfer Revenue deviation for each TSR as the product of the FMM TSR transfer schedule minus the DA transfer schedule and the difference between import and export FMM LMP for each EDAM BAA, including the CISO. System shall calculate the RTD TSR Transfer Revenue deviation for each TSR as the product of the TSR transfer ATF transfer tag minus the FMM transfer schedule and the difference between import and export RTD LMP for each EDAM BAA, including the CISO. RTM TSR transfer revenue deviation amount is the sum of the FMM TSR transfer revenue and the RTD transfer revenue deviation The system shall adjust the RTM TSR Transfer Revenue for all DA TSRs to account for RTM TSR Congestion Revenue associated with each base, static, and dynamic TSR before distributing as defined in EDAM-TSR-BRQ-19638 	Core	Settlements
EDAM-TSR-BRQ-19636	Calculate RTM TSR Transfer Revenue for WEIM ETSRs (static, dynamic, and base ETSRs) <ul style="list-style-type: none"> For base ETSRs: The system shall calculate the FMM ETSR Transfer Revenue deviation for each base ETSR as the product of the FMM ETSR transfer schedule minus the base transfer schedule and the difference between import and export FMM LMP for each WEIM BAA For base ETSRs: The system shall calculate the RTD ETSR Transfer Revenue deviation for each base ETSR as the product of the ETSR ATF transfer tag minus the FMM transfer schedule and the difference between import and export RTD LMP for each WEIM BAA For static and dynamic ETSRs: the system shall calculate the FMM ETSR Transfer Revenue deviation for each ETSR as the product of the FMM ETSR transfer schedule and the difference between import and export FMM LMP for each WEIM BAA, including the CISO. 	Core	Settlements

 California ISO	Technology	Template Version:	6.8
		Document Version:	6.1.7
Extended Day Ahead Market Business Requirements Specification - Planning		Date Created:	1/21/2026

ID#	Business Feature	Requirement Type	Potential Application(s) Impacted
	<ul style="list-style-type: none"> For static and dynamic ETSRs: the system shall calculate the RTD TSR Transfer Revenue deviation for each TSR as the product of the TSR ATF transfer tag minus the FMM transfer schedule and the difference between import and export RTD LMP for each WEIM BAA, including the CISO. The system shall adjust the RTM ETSR Transfer Revenue for each base, static, and dynamic ETSR to account for RTM ETSR Congestion Revenue associated with each base, static, and dynamic ETSR before distributing as defined in EDAM-TSR-BRQ-19638 		
EDAM-TSR-BRQ-19637	Calculate RTM ETSR Total Transfer Revenue <ul style="list-style-type: none"> The RTM ETSR total transfer revenue amount is the sum of all FMM ETSR transfer revenue and all RTD transfer revenue deviation 	Core	Settlements
EDAM-TSR-BRQ-19638	Allocate RTM TSR Transfer Revenue for Energy <ul style="list-style-type: none"> For all RT TSRs, the system shall allocate the RT TSR Transfer Revenue per the specified RDF in the Transfer Location definition between the EDAM BAAs on each side of the TSR (including CAISO BAA). For the BAA RT Transfer Revenue deviation associated with TSR Type 2 and a TCSC, the system shall directly allocate their portion of the Transfer Revenue to the TCSC. The BAA RT Transfer Revenue associated with a CRN ID "NONE" and TSR Type 2, that portion shall be allocated to the EESC, including CISO SC for the CISO BA The BAA RT Transfer Revenue associated with TSR Types 1, 3, and 4 as well as dynamic, static, and base ETSRs shall be allocated to the EESC, including CISO SC for the CISO BA, for sub-allocation <p>Notes: For CISO SC sub-allocation, refer to ISO BAA EDAM Participation Rules Initiative</p>	Core	Settlements
EDAM-TSR-BRQ-19640	Calculate RT TSR Deviation Congestion Revenue for Energy Associated with DA TSRs	Core	Settlements

 California ISO	Technology	Template Version:	6.8
		Document Version:	6.1.7 1.7
Extended Day Ahead Market Business Requirements Specification - Planning		Date Created:	1/21/2026

ID#	Business Feature	Requirement Type	Potential Application(s) Impacted
	<ul style="list-style-type: none"> • System shall calculate the FMM BAA TSR deviation Congestion Revenue for each DA TSR (all TSR types) as the product of the FMM TSR transfer schedule minus DA TSR transfer schedule times the TSR FMM MCC <ul style="list-style-type: none"> ○ FMM TSR deviation quantity= the FMM TSR transfer schedule minus DA TSR transfer schedule • System shall calculate the RTD BAA TSR deviation Congestion Revenue for each DA TSR (all TSR types) as the product of the TSR ATF transfer tag minus FMM TSR transfer schedule times the TSR RTD MCC <ul style="list-style-type: none"> ○ RTD TSR deviation quantity= TSR ATF transfer tag minus FMM TSR transfer schedule 		
EDAM-TSR-BRQ-19641	<p>Calculate RT ETSR Deviation Congestion Revenue for Energy Associated with WEIM ETSRs</p> <ul style="list-style-type: none"> • For base ETSRs: System shall calculate the FMM BAA ETSR deviation Congestion Revenue for each base ETSR as the product of the FMM ETSR transfer schedule minus the base ETSR transfer schedule times the ETSR FMM MCC <ul style="list-style-type: none"> ○ FMM ETSR deviation quantity= the FMM ETSR transfer schedule minus base ETSR transfer schedule • For base ETSRs: System shall calculate the RTD BAA ETSR deviation Congestion Revenue for each base ETSR as the product of the ETSR ATF transfer tag minus the FMM ETSR transfer schedule times the ETSR RTD MCC <ul style="list-style-type: none"> ○ RTD ETSR deviation quantity= ETSR ATF transfer tag minus FMM ETSR transfer schedule • For static and dynamic ETSRs: System shall calculate the FMM BAA ETSR deviation Congestion Revenue for each static and dynamic ETSR as the product of the FMM ETSR transfer schedule times the ETSR FMM MCC <ul style="list-style-type: none"> ○ FMM ETSR deviation quantity=FMM ETSR transfer schedule • For static and dynamic ETSRs: System shall calculate the RTD BAA ETSR deviation Congestion Revenue for each 	Core	Settlements

 California ISO	Technology	Template Version:	6.8
		Document Version:	6.1.7
Extended Day Ahead Market Business Requirements Specification - Planning		Date Created:	1/21/2026

ID#	Business Feature	Requirement Type	Potential Application(s) Impacted
	static and dynamic ETSR as the product of the ETSR ATF transfer tag minus the FMM ETSR transfer schedule times the ETSR RTD MCC <ul style="list-style-type: none"> ○ RTD ETSR deviation quantity= ETSR ATF transfer tag minus FMM ETSR transfer schedule 		
EDAM-TSR-BRQ-19642	Calculate the RTM ETSR Total Congestion Revenue <ul style="list-style-type: none"> • The system shall calculate the RTM ETSR total Congestion Revenue as the sum of all FMM BAA ETSR deviation congestion revenue plus the all RTD BAA ETSR deviation congestion revenue 	Core	Settlements
EDAM-TSR-BRQ-19643	Allocation of RT ETSR Total Congestion Revenue to WEIM BAAs <ul style="list-style-type: none"> • The system shall allocate the RT ETSR total congestion revenue to a WEIM BAA based upon the deviation quantities identified in EDAM-TSR-BRQ-19640 and 19641 times the relevant FMM TSR MCC sub-component price associated with each DGAP-TIE and each TRANSFER_LOCATION ID, FMM ETSR MCC sub-component price associated with each DGAP-TIE and each TRANSFER_LOCATION ID, RTD TSR MCC sub-component price associated with each DGAP-TIE and each TRANSFER_LOCATION ID, and RTD ETSR MCC sub-component price associated with each DGAP-TIE and each TRANSFER_LOCATION ID 	Core	Settlements
EDAM-BRQ-18915	Calculate and publish aggregate UIE Load Price for all loads in each BAA in the EDAM and WEIM <p>Note: This BAA-level UIE is not used for any settlements but is provided to Entities as reference data; this is a derived price for information use only.</p>	Core	Settlements
<u>EDAM-BRQ-18930</u>	<u>New Role for EDAM Entity to View Submitted Meter Data for their BAA only</u> <p><u>Create a new MRI-Meter read-only role for EDAM Entity to access submitted meter data for resources within their BAA only</u></p>	<u>Process</u>	<u>AIM</u>

 California ISO	Technology	Template Version:	6.8
		Document Version:	4.6 1.7
Extended Day Ahead Market Business Requirements Specification - Planning		Date Created:	1/21/2026

ID#	Business Feature	Requirement Type	Potential Application(s) Impacted
<u>EDAM-BRQ-18932</u>	<p><u>Allow EDAM Entity to Access MRI-Meter Data for their BAA</u></p> <ul style="list-style-type: none"> • <u>EDAM Entity shall use the new role to view meter data (described in EDAM-BRQ-18930) to view submitted meter data for resources in their BAA (read-only access)</u> • <u>Data shall be retrievable via API</u> 	<u>Core</u>	<u>MRI-S</u>
<u>EDAM-BRQ-18935</u>	<p><u>Do not assess the SCID charge for SCs representing both EDAM resources or wheel throughs and a WEIM Entity</u></p> <ul style="list-style-type: none"> • <u>The system shall not assess the SCID Charge for any SCID issued to an SC that represents both a WEIM Entity and an EDAM resource or resources that source or sink to the same WEIM BAA that the SC is affiliated with</u> • <u>The system shall not assess the SCID Charge for any SCID issued to an SC that represents both a WEIM Entity and a wheel-through transaction located in an EDAM BAA that sources from or sinks to the WEIM BAA that the SC is affiliated with</u> 	<u>Process</u>	<u>Settlements</u>

 California ISO	Technology	Template Version:	6.8
		Document Version:	6.1.7
Extended Day Ahead Market Business Requirements Specification - Planning		Date Created:	1/21/2026

5.16 Business Process: Manage Market Reporting (CMRI, OASIS)

- Extend DAM reports, results, and schedules to EDAM
- Report DA RSE binding and final results and pool compositions
- Report DA TSRs and tags
- Report GHG attributions (DA and RT)

5.16.1 Business Requirements

ID#	Business Feature	Requirement Type	Potential Application(s) Impacted
EDAM-BRQ-20000	Extend DA Market Results to EDAM resources System shall extend DA market results reports to EDAM.	Existing	CMRI
EDAM-BRQ-20010	TSR Reporting for Transmission Customers and EDAM Entities on each side of the transfer <ul style="list-style-type: none"> • Include TSR Type, SIBR submitted schedule, and limit 	Core	CMRI
EDAM-BRQ-20011	TSR Reporting for Transmission Customers and EDAM Entity SCs on each side of the transfer <ul style="list-style-type: none"> • TSR awards for EN, IRU/IRD, RCU/RCD 	Core	CMRI
EDAM-BRQ-20020	Report on DA GHG Attributions to include multiple GHG areas for Resource SC <ul style="list-style-type: none"> • GHG Area: CA Attributions (CA GHG Awards) • GHG Area: WA Attributions (WA GHG Awards) 	Core	CMRI
EDAM-BRQ-20022	Create new report for DA GHG Reference MW <ul style="list-style-type: none"> • New product: Resource GHG reference point from GHG pass 	Core	CMRI
EDAM-BRQ-20023	Report on DA GHG Attributions to include multiple GHG areas for EDAM Entity <ul style="list-style-type: none"> • GHG Area: CA Attributions (CA GHG Awards) • GHG Area: WA Attributions (WA GHG Awards) 	Core	CMRI
EDAM-BRQ-20030	Report on RT (include both FMM and RTD) GHG Attributions to include multiple GHG Areas for Resource SC <ul style="list-style-type: none"> • GHG Area: CA attributions (CA GHG Awards) • GHG Area: WA attributions (WA GHG Awards) 	Core	CMRI

 California ISO	Technology	Template Version:	6.8
		Document Version:	6.1.7 1.7
Extended Day Ahead Market Business Requirements Specification - Planning		Date Created:	1/21/2026

ID#	Business Feature	Requirement Type	Potential Application(s) Impacted
EDAM-BRQ-20031	Report on RT (include both FMM and RTD) GHG Attributions to include multiple GHG Areas for EDAM Entity <ul style="list-style-type: none"> • GHG Area: CA attributions (CA GHG Awards) • GHG Area: WA attributions (WA GHG Awards) 	Core	CMRI
EDAM-BRQ-20035	Extend to EDAM Resources: Greenhouse Gas Bid Cap Reporting <ul style="list-style-type: none"> • Extend to include EDAM resources • Add DAM as Market type • Add GHG area 	Core	CMRI
EDAM-BRQ-20040	Extend DA Commodity Price Report to EDAM resources <ul style="list-style-type: none"> • Generation Commodity prices for Energy, IRU/IRD, and RCU/RCD. • Import-Export Commodity prices for Energy, IRU/IRD, and RCU/RCD. • Demand Commodity Prices for Energy 	Existing	CMRI
EDAM-BRQ-20050	New report for both Resource Specific Advisory and Binding/Final RSE Run reports made available for the resource SC <ul style="list-style-type: none"> • Resource Awards for Energy, IRU/IRD, AS • New report in DA dropdown 	Core	CMRI
EDAM-BRQ-20051	New report for both Resource Specific Advisory and Binding/Final RSE Run reports made available for the EDAM Entity <ul style="list-style-type: none"> • Resource Awards for Energy, IRU/IRD, AS • Resource Bid Capacity Maximum • New report in EDAM dropdown 	Core	CMRI
EDAM-BRQ-20054	Allow the EDAM entity to view all resource schedules within the EDAM entity BAA Include: <ul style="list-style-type: none"> • Day-Ahead Generation Market Results (Generator schedules within the EDAM BA) showing all commodities, similar to the SC report 	Core	CMRI

 California ISO	Technology	Template Version:	6.8
		Document Version:	6.1.7
Extended Day Ahead Market Business Requirements Specification - Planning		Date Created:	1/21/2026

ID#	Business Feature	Requirement Type	Potential Application(s) Impacted
	<ul style="list-style-type: none"> ○ EN, IRU/IRD, RCU/RCD, and AS ● Day-Ahead Demand Market Results (Load schedules within the EDAM BA) ● DA Import-Export Schedules (within the EDAM BA) ● Day-Ahead Ancillary Service Market Results (AS Schedules) ● Day-Ahead Unit Commitments (DA commitment Grouped as part of a new “EDAM” tab) ● Two Day-Ahead Reliability Capacity Advisory Schedules 		
EDAM-BRQ-20057	New report for interchange schedule data broken down by CRN for both EDAM/WEIM entities and CAISO BA	Core	CMRI
EDAM-BRQ-20065	Extend DAM reports to EDAM BAAs <ul style="list-style-type: none"> ● System shall extend DAM reports to EDAM BAAs ● Includes DAM Demand, IRU/IRD, RCU/RCD requirements, transfer of EN/IR//RC, MPM, LMP, polynomial coefficients, public bids, and uplift Settlements reports. 	Existing	OASIS
EDAM-BRQ-20068	Publish EDAM BAA and WEIM BAA level constraint MPM results for DAM and RTM <ul style="list-style-type: none"> ● Market (IFM, RUC, RTPD, RTD) ● BAA ● Interval ● Constraint PBC (similar to existing Intertie Constraint Competitive Paths report) ● Constraint cause ● Shadow price: as the difference between BAA MEC and ISO MEC (similar to current constraint shadow price reports) 	Existing	OASIS
EDAM-BRQ-20070a	New Report for Aggregated/BAA Level Final/Binding RSE Report to EDAM BAAs <ul style="list-style-type: none"> ● EDAM BAA RSE hourly upward requirement, requirement with DB and deficiency (relax variable value) by commodities of upward 	Core	CMRI

 California ISO	Technology	Template Version:	6.8
		Document Version:	6.1.7 1.7
Extended Day Ahead Market Business Requirements Specification - Planning		Date Created:	1/21/2026

ID#	Business Feature	Requirement Type	Potential Application(s) Impacted
	Energy, RegU, Spin, NSpin, IRU, (upward deficiency for EN&IRU together) <ul style="list-style-type: none"> • EDAM BAA hourly downward requirement, requirement with DB and deficiency by Energy, RegD, IRD, (Downward deficiency EN&IRD together) • Include DA RSE Pass Indicator: provide the binding DA RSE pass/fail results • Include Slack variables by commodity (i.e., shortfall by commodity): the MW value by commodity of penalty when failing the RSE • Include constraint type • Include in EDAM dropdown (report should be visible to EDAM entities only) 		
EDAM-BRQ-20080	New Report for Aggregated RSE Advisory Run Results for EDAM BAAs <ul style="list-style-type: none"> • Report DAM-RSE advisory test schedules and pass/fail results to EDAM BAAs in same manner as for WEIM for each resource • Include pass indicator to denote the BAs that passed RSE: <ul style="list-style-type: none"> ○ DA RSE Pass Indicator: provide the advisory DA RSE pass/fail results <ul style="list-style-type: none"> ▪ Provided every 30 minutes • Include Slack variables by commodity (i.e., shortfall by commodity): the MW value by commodity of penalty when failing the RSE • Include in EDAM dropdown (report should be visible to EDAM entities only) 	Core	CMRI
EDAM-BRQ-20082a	New Aggregated RSE requirement transfer between EDAM BAAs <ul style="list-style-type: none"> • Consume hourly requirements, procurement requirement with DB, and RSE adjusted requirement by commodity by BAA for energy, AS and IRU, IRD <ul style="list-style-type: none"> ○ Test • Report the hourly RSE requirement, DB adjusted requirement and TSR adjusted requirement by 	Core	CMRI

 California ISO	Technology	Template Version:	6.8
		Document Version:	4.6 1.7
Extended Day Ahead Market Business Requirements Specification - Planning		Date Created:	1/21/2026

ID#	Business Feature	Requirement Type	Potential Application(s) Impacted
	commodity by EDAM BAAs for every RSE runs between 6 am and 10 am <ul style="list-style-type: none"> For CMRI publish: include in EDAM dropdown (report shall be visible to EDAM entities only) Note: Reporting will be combined with BRQ-20070a, which reports on the RSE binding run; total Transfer MW value will be added to the report to provide the adjustment MW impacting the requirement		
EDAM- TSR BRQ- 21005	New Report: TSR Reporting for TCSC <ul style="list-style-type: none"> For all transient TSRs created in SIBR for that TCSC, Type 2 TSRs dynamically matched in SIBR Include all TSR attributes, including: <ul style="list-style-type: none"> RES_ID: Resource ID SC_ID: Scheduling Coordinator MAX_CAP: Maximum Capacity TIE_ID: Intertie ID FROM_BAA: From side BAA TO_BAA: To side BAA IMPORT/EXPORT: Flow directions (I/E) TSR_TYPE: 2 RSE_YN: N TAG_YN: Tag Flag, based on default table in MF (TSR-BRQ-02305) MATCHING_TSR_ID: Matching TSR Resource ID TRANSFER_LOCATION 	Core	CMRI
EDAM- TSR BRQ- 21006	New Report: TSR Reporting for EESC <ul style="list-style-type: none"> For all transient TSRs created in SIBR in the EESC's BAA, Type 2 TSRs dynamically matched in SIBR Include all TSR attributes, including: <ul style="list-style-type: none"> RES_ID: Resource ID SC_ID: Scheduling Coordinator MAX_CAP: Maximum Capacity TIE_ID: Intertie ID FROM_BAA: From side BAA TO_BAA: To side BAA IMPORT/EXPORT: Flow directions (I/E) TSR_TYPE: 2 RSE_YN: N 	Core	CMRI

 California ISO	Technology	Template Version:	6.8
		Document Version:	4.61.7
Extended Day Ahead Market Business Requirements Specification - Planning		Date Created:	1/21/2026

ID#	Business Feature	Requirement Type	Potential Application(s) Impacted
	<ul style="list-style-type: none"> ○ TAG_YN: Tag Flag, based on default table in MF (TSR-BRQ-02305) ○ MATCHING_TSR_ID: Matching TSR Resource ID ○ TRANSFER_LOCATION 		
EDAM-BRQ-18910	<p>New Report: DA Resource Specific Schedule by Market Priority Type to EDAM Entity</p> <ul style="list-style-type: none"> ● Allow EDAM Entity SC to view report of DA/RUC Resource Specific Schedules by Market Priority type for that BAA's set of resources <ul style="list-style-type: none"> ○ In addition to Market Priority Type, report shall also include CRN ID and CRN Type fields 	Core	CMRI
EDAM-BRQ-18911	<p>Report on RT Resource Specific Schedule by Market Priority Type to EDAM Entity</p> <ul style="list-style-type: none"> ● Allow EDAM Entity SC to view report of RT (RTUC or RTPD/RTD) Resource Specific Schedules by Market Priority type for that BAA's set of resources <ul style="list-style-type: none"> ○ In addition to Market Priority Type, report shall also include CRN ID and CRN Type fields 	Core	CMRI
EDAM-IST-BRQ-20540	<p>New CMRI Report IST trades by BAA for the EDAM Entity</p> <ul style="list-style-type: none"> ● Report and display for DAM, RTM: <ul style="list-style-type: none"> ○ Name ○ Market Type ○ Start Time ○ Stop Time ○ Trade Quantity (this is FmSC) ○ Adjusted Trade Quantity ○ Depend on Trade Name Trade ○ Trade Status ○ Counter Trade Quantity (this is ToSC) ○ Trade Type (IST) ○ Trade Product Type APN, CPT, PHY) ○ From SC (Scheduling Coordinator) ○ To SC (Scheduling Coordinator) ○ Registered Generator 	Core	CMRI

 California ISO	Technology	Template Version:	6.8
		Document Version:	4.61.7
Extended Day Ahead Market Business Requirements Specification - Planning		Date Created:	1/21/2026

ID#	Business Feature	Requirement Type	Potential Application(s) Impacted
	<ul style="list-style-type: none"> • The report shall support interactive filtering and drill-down capabilities. • The IST trade report shall be retrievable via API 		
<u>EDAM-BRQ-20546</u>	<p><u>New Report to EDAM Entity: Settlement Calculated Market Balanced Contract Data</u></p> <ul style="list-style-type: none"> • <u>The system shall report on the settlement calculated market balanced contract data</u> <ul style="list-style-type: none"> ○ <u>Includes DA Balanced Quantity, Post-DA Balanced Quantity, and Final Balanced Quantity for ETC/TOR/OATT contracts</u> 	<u>Core</u>	<u>CMRI</u>
EDAM-BRQ-20070b	<p>Report on Imbalance Reserve <u>Requirement</u> Results from DA-RSE</p> <ul style="list-style-type: none"> • OASIS shall report on DA-RSE Imbalance Reserve <u>Requirement</u> Results as they are published from the DA-RSE (i.e., after each RSE run) for each EDAM BAA <p>Note: WEIM counterpart report is being moved from CMRI to OASIS as part of RSEE Phase 2 scope.</p>	Core	OASIS
EDAM-BRQ-20070c	<p>New Report for Aggregated/BAA Level Final/Binding RSE Report</p> <ul style="list-style-type: none"> • EDAM BAA RSE hourly upward requirement, requirement with DB and deficiency (relax variable value) by commodities of upward Energy, RegU, Spin, NSpin , IRU, (upward deficiency for EN&IRU together) • EDAM BAA hourly downward requirement, requirement with DB and deficiency by Energy, RegD, IRD, (Downward deficiency EN&IRD together) • For OASIS ATF publish: DO NOT publish results until TD+1 <ul style="list-style-type: none"> ○ Example: For DAM run on 10/14/24 (for TD 10/15/24), publish results at 00:00 on 10/16/24 	Core	OASIS (ATF Publish)

 California ISO	Technology	Template Version:	6.8
		Document Version:	4.6 1.7
Extended Day Ahead Market Business Requirements Specification - Planning		Date Created:	1/21/2026

ID#	Business Feature	Requirement Type	Potential Application(s) Impacted
EDAM-BRQ-20082b	New Aggregated RSE requirement Transfer between EDAM BAAs <ul style="list-style-type: none"> • Consume hourly requirements, procurement requirement with DB, and RSE adjusted requirement by commodity by BAA for energy, AS and IRU, IRD • Report the hourly RSE requirement, DB adjusted requirement and TSR adjusted requirement by commodity by EDAM BAAs for every RSE runs between 6 am and 10 am • For OASIS ATF publish: DO NOT publish results until TD+1 <ul style="list-style-type: none"> ○ Example: For DAM run on 10/14/24 (for TD 10/15/24), publish results at 00:00 on 10/16/24 <p>Note: Reporting will be combined with BRQ-20070b, which reports on the RSE binding run; total Transfer MW value will be added to the report to provide the adjustment MW impacting the requirement</p>	Core	OASIS (ATF Publish)
EDAM-BRQ-20084	New publish: Hourly advisory IRU/IRD requirements for each EDAM BAA for D+2 and D+3	Core	OASIS
EDAM-BRQ-20090	New Publish Net Transfer DA TSR <ul style="list-style-type: none"> • BAA aggregated net transfer DA TSR by<u>for</u> Energy, IRU/IRD, RCU/RCD 	Core	OASIS
EDAM-BRQ-20100	New Publish: total net GHG Import Transfer deemed for each GHG regulation area by market type <ul style="list-style-type: none"> • Breakdown for each market type (DA, FMM, RTD) for each GHG regulation area (CA and WA) <p>Note: previously called "Export Allocations" now called "Import Transfers"</p>	Core	OASIS
EDAM-BRQ-20105	Extend to EDAM: DA GHG Clearing Price Reporting by GHG Regulation Area <ul style="list-style-type: none"> • Consume DA GHG Clearing prices • Publish DA GHG clearing prices for EDAM GHG Regulation Area 	Core	OASIS

 California ISO	Technology	Template Version:	6.8
		Document Version:	6.1.7
Extended Day Ahead Market Business Requirements Specification - Planning		Date Created:	1/21/2026

ID#	Business Feature	Requirement Type	Potential Application(s) Impacted
EDAM-BRQ-20106	Extend to EDAM: RT GHG Clearing Price Reporting by GHG Regulation Area <ul style="list-style-type: none"> • Consume RT GHG Clearing prices • Publish RT GHG clearing prices for EDAM GHG Regulation Area 	Core	OASIS
EDAM-BRQ-20110	New Report the status of the energy profiles of the e-Tag as a result from the DAM (3 hours after DAM result publication) <ul style="list-style-type: none"> • Consume and report on preliminary Supply Test results 	Core	OASIS
EDAM-BRQ-20120	New Publish composition of Upward and Downward Pool at T-5 hours (5 hours before operating hour) <ul style="list-style-type: none"> • Consume EDAM Entity Tagging shortfall and resupply tests (from SIBR) at T-5 hours (5 hours before operating hour) • Gross import schedule • Gross import tagged • Gross upward re-supply: Aggregate incremental energy bid range above DA schedule, unencumbered by upward capacity awards • Publish composition of upward EDAM pool and downward EDAM pool and which BAAs are not included in the pools 	Core	OASIS
EDAM-BRQ-20120a	New Publish composition of Upward and Downward Pool at DAM Close <ul style="list-style-type: none"> • Consume EDAM Pool Results • Publish composition of upward EDAM pool and downward EDAM pool and which BAAs are not included in the pools 	Core	OASIS
EDAM-BRQ-20130	New Publish DA load forecasts for EDAM entities for each RSE run <ul style="list-style-type: none"> • Consume DA LF for EDAM Entity from pre-market for each DA RSE run. • Forecasts shall be locked at 9 am 	Core	OASIS

 California ISO	Technology	Template Version:	6.8
		Document Version:	6.1.7
Extended Day Ahead Market Business Requirements Specification - Planning		Date Created:	1/21/2026

ID#	Business Feature	Requirement Type	Potential Application(s) Impacted
EDAM-BRQ-20140	New Publish DA VER forecasts for EDAM entities for each RSE run <ul style="list-style-type: none"> • Consume DA VER forecast for EDAM Entity from pre-market for each DA RSE run. • Break down forecasts by resource type (solar vs. wind) • Forecasts shall be locked at 9 am 	Core	OASIS
EDAM-BRQ-20145	Extend to EDAM: Publish Requirement Thresholds for EDAM pools and sub-pools at DAM close and TH-5 hr. (if relevant) <ul style="list-style-type: none"> • Consume estimates for EDAM up/down pools and AET/non-AET sub-pools at the time that DAM results post and at TH-5 hr., if received • At T-5h: report shall include the Flex Ramp 15-minute and 5-minute input calculation data for AET and non-AET sub-groups, depending on AET elections • 	Core	OASIS
EDAM-BRQ-20146	Extend to EDAM: Publish Requirement Input Polynomials for EDAM pools and sub-pools at DAM close and TH-5 hr. (if relevant) <ul style="list-style-type: none"> • Consume estimates for EDAM up/down pools and AET/non-AET sub-pools at the time that DAM results post and at TH-5 hr., if received • At Th-5: Report shall include the Flex Ramp input calculation data for AET and non-AET, depending on AET elections • 	Core	OASIS
EDAM-BRQ-20147	Extend to EDAM: Publish Requirement Uncertainty Histograms for EDAM pools and sub-pools at DAM close and TH-5 hr. (if relevant) <ul style="list-style-type: none"> • Consume estimates for EDAM up/down pools and AET/non-AET sub-pools at the time that DAM results post and at TH-5 hr., if received 	Core	OASIS

 California ISO	Technology	Template Version:	6.8
		Document Version:	4.6 1.7
Extended Day Ahead Market Business Requirements Specification - Planning		Date Created:	1/21/2026

ID#	Business Feature	Requirement Type	Potential Application(s) Impacted
	<ul style="list-style-type: none"> At Th-5: Report shall include the Flex Ramp input calculation data for AET and non-AET, depending on AET elections 		
EDAM-BRQ-20150	Extend TD+90 Public Bids Reporting to EDAM <ul style="list-style-type: none"> Publish anonymized bids for energy, IRU/IRD and RCU/RCD products for EDAM entities 	Core	OASIS
EDAM-BRQ-20156	EDAM Net Export Transfer Constraint Input Parameters (new report): System shall publicly display the following input parameters to the Net EDAM Export Transfer Constraint for each EDAM BAA (ISO BAA inclusive), Trade Date, Trade Hour: <ul style="list-style-type: none"> EDAM BAA ID (filterable, inclusive of ISO BAA) Trade Date (filterable) Trade Hour (filterable) Reliability Margin Confidence Factor Activation Flag Stressed Hour (for ISO BAA only) <p>Multiple filters shall be cumulative.</p> <p>All reported fields shall be sortable and retrievable through API query by public viewers under the guidelines of Acceptable Use.</p>	Core	OASIS
EDAM-BRQ-20157	Update existing CAISO Demand Forecast Report to include 3DA—6DA Demand Forecasts <ul style="list-style-type: none"> Consume demand forecasts for 3DA, 4DA, 5DA and 6DA and include each as an option in the “Market/Process” dropdown <p>Note: report already includes 2DA and 7DA demand forecasts. 3DA—6DA shall be displayed in the same manner as the existing 2DA and 7DA reports.</p>	Core	OASIS

 California ISO	Technology	Template Version:	6.8
		Document Version:	4.61.7
Extended Day Ahead Market Business Requirements Specification - Planning		Date Created:	1/21/2026

ID#	Business Feature	Requirement Type	Potential Application(s) Impacted
EDAM-BRQ-20159	<p>Remove No Longer report on ETSR and TSR Shadow Price Reporting when EDAM goes live</p> <ul style="list-style-type: none"> • Due to the change from SMEC to BAA MECs, the following three displays shall be removed from <u>not report new data upon EDAM go-live:</u> “Constraint Type” dropdown at OASIS > PRICES > Shadow Prices > Scheduling Constraint Shadow Prices: <ul style="list-style-type: none"> ○ BAA TRANSFER DISTRIBUTION ○ ETSR LOWER LIMIT ○ <u>ETSR UPPER LIMIT</u> ○ <u>BAA Transfer Lower Limit</u> ○ <u>BAA Transfer Upper Limit</u> • <u>Historical data (reports provided before EDAM go-live) shall remain on OASIS</u> • No other change to existing report other than removal no new of ETSR shadow prices data 	Core	OASIS
EDAM-BRQ-20260	<p>No NPM related reports for the BAs that join EDAM</p> <p>Access Master File defined NPM, EDAM</p>	Process	CMRI, OASIS
EDAM-BRQ-20275	<p>Extend to EDAM: Publish RTM Flexible Ramp Scheduling Point/Tie Nodal Prices by Direction (Import/Export)</p> <p>Upon data receipt, System shall report the following RTM FR market results data (original and corrected) for Scheduling Points/Tie Combinations by direction (import/export):</p> <ul style="list-style-type: none"> • Nodal 15-min & 5-min Data <ul style="list-style-type: none"> ○ FRUMP/FRDMP Nodal Prices but excluding their price breakdown, and sub-components of MCC prices (by BAA). 	Core	OASIS
<u>EDAM-BRQ-20288</u>	<p><u>Extend to EDAM: Publish RUC RC Aggregate Awards by TAC Area by Type</u></p> <ul style="list-style-type: none"> • <u>System shall report the following RUC aggregate hourly data for each TAC Area, broken down by</u> 	<u>Core</u>	<u>OASIS</u>

 California ISO	Technology	Template Version:	6.8
		Document Version:	6.1.7
Extended Day Ahead Market Business Requirements Specification - Planning		Date Created:	1/21/2026

ID#	Business Feature	Requirement Type	Potential Application(s) Impacted
	<u>Generation, Import, Load, Export (original and corrected):</u> <ul style="list-style-type: none"> o <u>RCU Awards (including Proxy RCU MW) minus RCD Awards</u> • <u>These aggregate data shall replace the retired RUC Capacity in the same OASIS report.</u> 		
EDAM-DARA-BRQ-105	<p>Generate PDF and/or Excel/CSV reports, specific to each EDAM BAA, to display the following outputs for a given TD (DA1, DA2, and DA3 runs), Market pass (IFM, MPM, RUC), and hour (if applicable):</p> <ul style="list-style-type: none"> • Binding Constraints Flowgates • Binding Constraints Nomograms • Non-Binding Constraints - Flowgates • Nomogram Operating Points • Scalable Vector Graphics (SVG) One Lines • Equipment Out Summary - Line/PS/Trans (FERC 881 requirements for AR & Seasonal) • AS Summary • MOC Results • Resource Congestion • ACC Schedules <p>Notes:</p> <ul style="list-style-type: none"> • Each EDAM Entity shall receive their own reports and should not have access to other EDAM BAA data • Any discrepancies between data in WebOMS, the DAM, and OE tools must be addressed in coordination with EDAM Entities 	Process	N/A
EDAM-DARA-BRQ-110	<p>Email each EDAM BAA the set of DAM reports specific to their EDAM BAA for a given TD (DA1, DA2, and DA3 runs), Market pass (IFM, MPM, RUC), and hour (if applicable):</p> <ul style="list-style-type: none"> • Reports shall be shared when data is made available, per the determination of the CAISO RT Market Operator • Use default generic email addresses defined during market simulation 	Process	N/A

 California ISO	Technology	Template Version:	6.8
		Document Version:	4.6 1.7
Extended Day Ahead Market Business Requirements Specification - Planning		Date Created:	1/21/2026

 California ISO	Technology	Template Version:	6.8
		Document Version:	6.1.7
Extended Day Ahead Market Business Requirements Specification - Planning		Date Created:	1/21/2026

5.17 Manage FERC Reporting

- Publish EDAM Market Data to FERC
- Publish EDAM Settlements Data to FERC

5.17.1 Business Requirements

ID#	Business Feature	Requirement Type	Potential Application(s) Impacted
EDAM-BRQ-20227	Extend Publish of DAME-related data to EDAM to FERC System shall extend consume, store, and publish FERC DAME data to EDAM.	Core	Internal ISO System
EDAM-BRQ-20230	Publish EDAM Market Data to FERC System shall have the capability to automatically consume, store, and publish the following data to FERC: <ul style="list-style-type: none"> • EDAM binding Market Data, including DAM-RSE data 	Core	Internal ISO System
EDAM-BRQ-20235	Consume, Store, and Publish Price Corrected Data <ul style="list-style-type: none"> • Extend to EDAM: Consume Price Corrected data • New in EDAM: Consume any corrected GHG Clearing Prices (by GHG Regulation Area) 	Core	Internal ISO System
EDAM-BRQ-20240	Publish EDAM Settlements Data to FERC System shall have the capability to automatically consume, store, and publish the following data to FERC: <ul style="list-style-type: none"> • EDAM Settlements Charge Codes 	Core	Internal ISO System
EDAM-BRQ-20242	Consume/Access, Store and Publish DR LF Adjustment Data to FERC System shall the capability to automatically consume/access, store and publish the following data for EDAM BAAs to FERC: <ul style="list-style-type: none"> • ALFS-DF-Submitted DR LF Adjustments • STF- DR LF Adjustments 	Core	Internal ISO System

 California ISO	Technology	Template Version:	6.8
		Document Version:	4.6 1.7
Extended Day Ahead Market Business Requirements Specification - Planning		Date Created:	1/21/2026

ID#	Business Feature	Requirement Type	Potential Application(s) Impacted
EDAM-CRA-BRQ-20276c	Consume, Store, and Publish Parallel Flow Congestion Revenue Data <ul style="list-style-type: none"> • Include Settlement data for parallel flow congestion revenue in FERC reporting 	Core	Internal ISO System
EDAM-BRQ-18908f	Report Corrected DA-RSE Data to FERC	Core	Internal ISO System
EDAM-CRA-BRQ-20276c	Include Settlement data for parallel flow congestion revenue in Reporting to FERC	Core	Internal ISO System

 California ISO	Technology	Template Version:	6.8
		Document Version:	4.61.7
Extended Day Ahead Market Business Requirements Specification - Planning		Date Created:	1/21/2026

5.18 Manage Outages (WebOMS) and Constraints (PLC)

- Allow EDAM entity to activate/deactivate constraints

5.18.1 Business Requirements

ID#	Business Feature	Requirement Type	Potential Application(s) Impacted
EDAM-BRQ-22048b	<p>Add Control area field BAA in the UI Contingency screen</p> <ul style="list-style-type: none"> • Add Display BAA with associated contingency • Remove Sub control area field in Contingency UI screen 	Core	WebOMS
EDAM-BRQ-22049	<p>Allow EDAM entity to access Market Impact Tab in WebOMS</p> <ul style="list-style-type: none"> • Access MF defined EDAM Entity and associated EDAM BAAs • Allow EDAM entity to access the WebOMS Market Impact Tab for the EDAM BAAs <ul style="list-style-type: none"> ○ EDAM Entity access (view, submit and modify) to Market Impact tab shall only be restricted to Contingency and Flowgate. ○ Real-Time Market Operator (RTMO)'s access to Market Impact shall be expanded to EDAM Entity's transmission outages. ○ System shall be updated to display TOPA for each contingency on Market Impact tab. ○ EDAM Entity shall only be able to view/modify Market Impacts on outage cards created by their computed Transmission Operator Provider (TOP). ○ Other TOPs that are not EDAM participants shall not be allowed to view the Market Impacts tab on any outage card, including their own. 	Core	WebOMS AIM

 California ISO	Technology	Template Version:	6.8
		Document Version:	6.1.7
Extended Day Ahead Market Business Requirements Specification - Planning		Date Created:	1/21/2026

ID#	Business Feature	Requirement Type	Potential Application(s) Impacted
	<ul style="list-style-type: none"> ○ EDAM Entity shall not have the ability to view the Market Impacts (contingency/flowgates) on transmission outages where they are not the participant creating the outage but they are one of the computed TOPs if the outage card has shared equipment belonging to this EDAM Entity. 		
EDAM-BRQ-22050	<p>Allow EDAM entity to activate/deactivate constraints</p> <ul style="list-style-type: none"> • Consume EDAM entity submitted status of activate/deactivate constraints through API/UI <ul style="list-style-type: none"> ○ Flowgate ○ Input conformance for Flowgate constraints for IFM and RTM <p>Contingencies</p> <ul style="list-style-type: none"> • CAISO operators shall continue to use Outage cards to set the status of constraints as they do today <p>Notes</p> <ul style="list-style-type: none"> • DAM will use the latest set of Activated/De-activated constraints statuses that are consumed before DAM market runs (by 9 am, enforced by DAM). • Support incremental changes on default status of constraints. • Operations Engineering to determine the flowgate enforcement only or include conformance available to EDAM BAA. 	Core	WebOMS
EDAM-DARA-BRQ-610	<p>Allow EDAM entity to access Nomogram in Market Impact Tab in WebOMS</p> <ul style="list-style-type: none"> • Access MF defined EDAM Entity and associated EDAM BAAs 	Core	WebOMS

 California ISO	Technology	Template Version:	6.8
		Document Version:	6.1.7
Extended Day Ahead Market Business Requirements Specification - Planning		Date Created:	1/21/2026

ID#	Business Feature	Requirement Type	Potential Application(s) Impacted
	<ul style="list-style-type: none"> • Allow EDAM entity to access the WebOMS Market Impact Tab for the EDAM BAAs (Figure 1) <ul style="list-style-type: none"> ○ EDAM Entity access (view, submit and modify) to Market Impact tab shall allow for access of its BAA associated Nomograms, in addition to Contingencies and Flowgates. <p>Notes</p> <ul style="list-style-type: none"> • Once EDAM BAA joins the EDAM, EDAM entity shall be allowed to access Market impact tab in WebOMS for its BAA's contingencies, nomograms, flowgates • In the WebOMS, only TOP can access transmission outages and Market Impact Tab. 		
EDAM-DARA-BRQ-620	<p>Allow EDAM entity to activate/deactivate Nomograms for its BAA</p> <ul style="list-style-type: none"> • Allow EDAM entity to activate/deactivate Nomogram through UI <ul style="list-style-type: none"> ○ Nomograms activated/deactivated status for IFM and RTM in OMS Mkt Impacts tab its BAA associated Nomogram • CAISO operators shall continue to use Outage cards to set the status of nomogram as they do today <p>Notes</p> <ul style="list-style-type: none"> • DAM will use the latest set of Activated/De-activated status of constraints, nomograms statuses that are consumed before DAM runs (by 9 am, enforced by DAM). • CISO OE/operator will work with EDAM entity to update conformance to EDAM BAA through market. 	Core	WebOMS

 California ISO	Technology	Template Version:	6.8
		Document Version:	6.1.7
Extended Day Ahead Market Business Requirements Specification - Planning		Date Created:	1/21/2026

ID#	Business Feature	Requirement Type	Potential Application(s) Impacted
EDAM-DARA-BRQ-640	<p>Allow EDAM entity to access MOC and submit MOC definition</p> <p>Allow EDAM Entity to access Market Impact tab, free text input boxes: Generation Requirements, MOC, and Market Notes</p> <ul style="list-style-type: none"> • To define MOC, under MOC section, write in free text <ul style="list-style-type: none"> ○ List all the generation unit resource IDs included in the MOC ○ Specify the MOC requirement MW ○ Enter the reason for the MOC <p>Notes:</p> <ul style="list-style-type: none"> • CAISO Operations Engineering will receive and review EDAM entity's free text inputs and will work with the EDAM Entity to define and activate the MOC in the market system (manual process). 	Existing	WebOMS
<u>EDAM-BRQ-09030</u>	<p><u>Differentiate Between Submitted Constraint Types</u></p> <p><u>The system shall be able to classify different constraint types submitted by the entity (e.g., ITC and Branch group constraints).</u></p>	<u>Core</u>	<u>PLC</u>

 California ISO	Technology	Template Version:	6.8
		Document Version:	6.1.7
Extended Day Ahead Market Business Requirements Specification - Planning		Date Created:	1/21/2026

5.19 Business Process: Market/Business Simulation

This section shall provide a basis for the development of the Market/Business Simulation Scenarios. These requirements will provide guidance on the market participant impacts, inputs into the Scenarios, endpoints to the Scenarios and reasons for potential Scenarios. The guidance on market participant impacts shall be gathered from the requirements that impact rules, interfaces, applications/reports, new system processes, new/modified data models, and new user roles. The source and sink systems shall be determined through the development of the system context diagram and the web service requirements. The *Reason for the Potential Scenario* column will be to offer guidance regarding what potential scenarios, and their context, may be needed for this project. This section applies to all policy development projects, market enhancements, technology enhancements, operation enhancements, Energy Imbalance Market (EIM) implementations, and Reliability Coordination (RC) service implementations. If the project team has deemed that no structured testing is needed, an end-to-end test case must be specified.

In the Reason for Potential Scenario column, select one or more of the following reasons:

1. **Rule Impacts:** Generalized changes in market rules, bidding rules, settlements rules, market design changes, or other business rules.
2. **Interface changes:** Changes that impact templates (e.g., the Resource Adequacy (RA) supply plan), user interface (UI), and application programming interface (API) (e.g., retrievals of new shadow Settlements data).
3. **New application/report:** Changes that cause addition/modification of market software or reports, especially when market data input is required by the market participant.
4. **New system process:** Modification of data flow in systems, especially if the new process requires the market participant to demonstrate proficiency prior to production.
5. **New/Modified model data:** Addition or substantial modification of model data as a market solution or export provided by the ISO.
6. **New user role:** The addition or modification of access permissions for a user role applied to specific business units within an EIM entity or market participant organization (e.g., Load Serving Entity (LSE) as a Local Regulatory Authority (LRA) role). Scenarios are beneficial for market participants taking on a new function or process within their organization.

 California ISO	Technology	Template Version:	6.8
		Document Version:	4.6 1.7
Extended Day Ahead Market Business Requirements Specification - Planning		Date Created:	1/21/2026

5.19.1 Business Requirements

ID#	Guidance on Market Participant Impacts	Source System	Sink System	Reason for Potential Scenario
EDAM-MSIM-BRQ-24020	EDAM Market Simulation pre-condition On condition of <ul style="list-style-type: none"> • On-boarding entity • Connectivity • EDAM entity operator Training • Interface, integration 	TBD <u>Process</u>	TBD <u>Process</u>	EDAM On-Boarding
EDAM-MSIM-BRQ-24040	SC submit bids Entity shall submit AS requirements EDAM resource SC shall submit supply, demand bids, Submit CB bids, GHG bids for the GHG area, IRU/IRD bids, RCU/RCD bids All resources including non-participating will need integration ISO run and publish market award and Locational prices, Settlements Instruct EDAM/NPM entities/SC to submit load bids of rolling 7 days in DAM to address the potential market failure due to lack of load bids	<ul style="list-style-type: none"> • MP 	<ul style="list-style-type: none"> • SIBR • CMRI • OASIS Settlements	<ol style="list-style-type: none"> 1. Rule Impacts 2. Interface changes 3. new application /report 4. New system process

 California ISO	Technology	Template Version:	6.8
		Document Version:	6.1.7
Extended Day Ahead Market Business Requirements Specification - Planning		Date Created:	1/21/2026

ID#	Guidance on Market Participant Impacts	Source System	Sink System	Reason for Potential Scenario
EDAM-MSIM-BRQ-24060	EDAM entity, TO submit TSR limits Submit TSR limits Market will associate the attributes: RSE, pathway, RSE commodity, and CRN	<ul style="list-style-type: none"> MP 	<ul style="list-style-type: none"> SIBR CMRI OASIS Settlements 	1. Rule Impacts 2. Interface changes 3. new application /report 4. New system process
EDAM-MSIM-BRQ-24100	DA-RSE tests Entity view the test at 6 am, 9 am, and 10 am RSE result ISO run RSE, publish results	<ul style="list-style-type: none"> DA-RSE 	<ul style="list-style-type: none"> SIBR CMRI OASIS Settlements 	1. Rule Impacts 2. Interface changes 3. new application /report 4. New system process
EDAM-MSIM-BRQ-24120	EDAM GHG pass and GHG award SCs to submit GHG bids ISO runs GHG pass and IFM Publish GHG resource reference, and GHG awards	<ul style="list-style-type: none"> GHG Reference Pass 	<ul style="list-style-type: none"> SIBR CMRI OASIS Settlements 	1. Rule Impacts 2. Interface changes 3. New application /report 4. New system process

 California ISO	Technology	Template Version:	6.8
		Document Version:	4.61.7
Extended Day Ahead Market Business Requirements Specification - Planning		Date Created:	1/21/2026

ID#	Guidance on Market Participant Impacts	Source System	Sink System	Reason for Potential Scenario
EDAM-MSIM-BRQ-24140	<p><u>Gross Import Tag Submission and Tag & Resupply Test</u></p> <ol style="list-style-type: none"> 1. <u>EDAM entity to submit gross import tag DA schedule TSR tags</u> 2. <u>ISO system will perform tag and resupply test</u> 3. <u>Based on tag and resupply test, ISO system determines the EDAM BAA pool composition for the upward direction.</u> 4. <u>Pool composition is provided on OASIS</u> <p>ISO to check the tags to determine the EDAM pools in RTM RSE</p>	<ul style="list-style-type: none"> • <u>RTSI</u> • <u>SIBR</u> 	<ul style="list-style-type: none"> • RTM • CMPI • OASIS 	Rule Impacts
EDAM-MSIM-BRQ-24160	<p>EDAM Entity activate constraints, adjustment</p> <ul style="list-style-type: none"> • Net transfer out constraint activation • Activate contingencies/flowgates • Activate the nomogram • Activate MOC • DR adjustment for load <p>ISO shall enforce the constraint</p>	<ul style="list-style-type: none"> • SIBR • WebOMS 	<ul style="list-style-type: none"> • DAM 	2. Interface changes

 California ISO	Technology	Template Version:	6.8
		Document Version:	6.1.7
Extended Day Ahead Market Business Requirements Specification - Planning		Date Created:	1/21/2026

ID#	Guidance on Market Participant Impacts	Source System	Sink System	Reason for Potential Scenario
EDAM-MSIM-BRQ-24220	Settlements for EDAM EDAM resource Settlements extended from DAM, and DAME TSR for En/IR/RC TRR allocation EDAM GMC Surcharge for RSE failure RTM deviation Settlements for En/GHG/FRP/TSR BCR	<ul style="list-style-type: none"> Settlements 	Settlements	Confirm proper Settlements
EDAM-MSIM-BRQ-24240	DR LF Adjustment Submission via ALFS-SOA API (refer to RSEE2-MSIM-10140) <ul style="list-style-type: none"> Set up a scenario where EDAM Entity participants signed required attestation and submit DR LF Adjustments via ALFS-SOA API (that reflect Non-Participating DR Schedules), on LF zone level, to CAISO. Run market (DAM). Follow the results in the sink systems. 	<ul style="list-style-type: none"> ALFS-SOA 	<ul style="list-style-type: none"> CMRI OASIS 	1. Rule Impact 5. New/Modified model data
EDAM-MSIM-BRQ-24245	RA Imports <ul style="list-style-type: none"> RA suppliers define SR (for Generic RA) and TGs (for Flex and Generic RA) in MF to support month-ahead RA showings for RA imports from EDAM BAAs RA supplier SC submits RA obligation reassignments to physical resources in CIRA by 8 am before the DAM run to ensure 	<ul style="list-style-type: none"> CIRA SIBR 	<ul style="list-style-type: none"> IFM/RTM Settlements 	1. Rule Impacts 2. Interface changes 4. New system process

 California ISO	Technology	Template Version:	6.8
		Document Version:	6.1.7
Extended Day Ahead Market Business Requirements Specification - Planning		Date Created:	1/21/2026

ID#	Guidance on Market Participant Impacts	Source System	Sink System	Reason for Potential Scenario
	obligation transfer functions and RAAIM settlements are correctly assessed <ul style="list-style-type: none"> ○ DA reassignment carries over to RT • SC submits DA bids on resources with DA RA obligation • Settlements assesses RAAIM based on RA obligation reassignment and bid submission status 			
EDAM-CRA-MSIM-BRQ-24250	<p>SC submitted Self-schedule for the resource associate a CRN with financial flag that eligible for CRA</p> <ul style="list-style-type: none"> • balanced self-schedules • Self-schedules are not balanced <ul style="list-style-type: none"> ○ Note: balanced portion eligible for CRA settlement below <p>Settlements for CRA</p> <ul style="list-style-type: none"> • Manage OATT or Legacy Contracts balanced self-schedule Congestion Adjustment, credit to EDAM entity schedule where located, reversal to EDAM entity where congestion located • For CAISO BAA, OATT balanced self-schedule Congestion Adjustment will be included in the CRR balance account • For other EDAM BAAs, OATT balanced self-schedule Congestion Adjustment will be included in the EDAM Congestion Offset 	<ul style="list-style-type: none"> • SIBR 	<ul style="list-style-type: none"> • Settlement 	1. Rule Impacts

 California ISO	Technology	Template Version:	6.8
		Document Version:	6.1.7
Extended Day Ahead Market Business Requirements Specification - Planning		Date Created:	1/21/2026

ID#	Guidance on Market Participant Impacts	Source System	Sink System	Reason for Potential Scenario
	<ul style="list-style-type: none"> TOR/ETC contracts balanced self-schedule demand will be exempted from the measured demand for Tier 2 cost allocations for Imbalance Reserve and Reliability Capacity. EDAM legacy contracts are TOR/ETC contracts outside CISO BAA. 			

 California ISO	Technology	Template Version:	6.8
		Document Version:	4.6 1.7
Extended Day Ahead Market Business Requirements Specification - Planning		Date Created:	1/21/2026

Appendices

Appendix A: Formulas, Calculation Details, and Examples

Appendix A0: Acronym Definition

Acronym	Definition
A2A	Application-to-Application
ABC	Available Balancing Capacity
ACL	Access Control List
ADS	Automatic Dispatch System
AET	Assistance Energy Transfer
AGC	Automatic Generation Control
AIM	Access and Identity Management
AM	Additional Margin
AMS	Agreement Management System
ALFS	Automated Load Forecast System
Anode	Aggregate Node
API	Application Program Interface
Apnode	Aggregate Pricing Node
AS	Ancillary Services
AUX	Auxiliary
B2B	Business-to-Business
BA	Business Analyst
BAA	Balancing Authority Area
BAAOP	Balancing Authority Area Operations Portal

 California ISO	Technology	Template Version:	6.8
		Document Version:	6.1.7
Extended Day Ahead Market Business Requirements Specification - Planning		Date Created:	1/21/2026

Acronym	Definition
BARC	Balancing Authority Requirements Calculator
BCR	Bid Cost Recovery
BPM	Business Process Manual
BRS	Business Requirement Specifications
BSAP	Base Schedule Aggregation Portal
BSC	Base Schedule Coordinator
BSSD	(WEIM) Base Schedule Submission Deadline
CAISO	California Independent System Operator
CB	Convergence Bidding
CC	Commitment Cost
CCDEBE	Commitment Costs and Default Energy Bid Enhancements
CDN	Conformed Dispatch Notice
CF	Confidence Factor
CIM	Common Information Model
CIP	Critical Infrastructure Protection
CIRA	Customer Interface for Resource Adequacy
CISO	California Independent System Operator
CLAP	Custom Load Aggregation Point
CMRI	Customer Market Results Interface
Cnode	Connectivity Node
COG	Constrained-Output Generator
CPM	Capacity Procurement Mechanism

 California ISO	Technology	Template Version:	6.8
		Document Version:	6.8 1.7
Extended Day Ahead Market Business Requirements Specification - Planning		Date Created:	1/21/2026

Acronym	Definition
CRN	Contract Reference Number
CRR	Congestion Revenue Rights
CRRS	Congestion Revenue Rights Settlements (aka CRR Clawback system)
CSS	Critical Systems Support
DA	Day-Ahead
DAB	Default Availability Bid
DACA	Day-Ahead Contingency Analysis
DAECON	Day-Ahead Economic
DALPT	Day-Ahead Low Price Taker (low priority)
DAM	Day-Ahead Market
DAPT	Day-Ahead Price Taker (high priority)
DART	Day-Ahead Reliability Tool
DCPA	Dynamic Competitive Path Assessment
DCC	Default Commitment Cost
DEB	Default Energy Bid
DER	Distributed Energy Resource
DF	Demand Forecast
DGAP	Default Generation Aggregation Point
DLAP	Default Load Aggregation Point
DMLC	Default Minimum Load Cost
DMM	Department of Market Monitoring
DOP	Dispatch Operating Point

 California ISO	Technology	Template Version:	6.8
		Document Version:	4.6 1.7
Extended Day Ahead Market Business Requirements Specification - Planning		Date Created:	1/21/2026

Acronym	Definition
DOT	Dispatch Operating Target
DR	Demand Response
DRP	Demand Response Program
DSA	Dynamic Stability Analysis
DSTC	Default State Transition Cost
DSUC	Default Start Up Cost
ECIC	Energy Costs and Index Calculator
ECON	Economic
ED	Exceptional Dispatch
EDAM	Extended Day-Ahead Market
EDR	Enterprise Data Repository
EE	Expected Energy
EEA	Expected Energy Allocation
EESC	Energy Imbalance Market Entity Scheduling Coordinator
EFC	Effective Flexible Capacity
EGAP	EIM Default Generation Aggregation Point
ELAP	EIM Load Aggregation Point
EMM	Enterprise Model Management
EMMS	Enterprise Model Management System
EMNA	Energy Management Network Application
EMS	Energy Management System
EN	Energy

 California ISO	Technology	Template Version:	6.8
		Document Version:	4.6 1.7
Extended Day Ahead Market Business Requirements Specification - Planning		Date Created:	1/21/2026

Acronym	Definition
EPI	Electricity Price Index
ESP	Electronic Security Perimeter
ETC	Existing Transmission Contract
ETSR	Energy Transfer System Resources
FDR	Forecast Data Repository
FERC	Federal Energy Regulatory Commission
FMCA	Fifteen-Minute Contingency Analysis
FMM	Fifteen-Minute Market
FMU	Frequently Mitigated Unit
FNM	Full Network Model
FODD	FERC Outgoing Data Depository
FSP	Forecast Service Provider
FRCT	Forbidden Region Crossing Time
FRD	Flexible Ramp Down
FRU	Flexible Ramp Up
GDF	Generation Distribution Factor
GHG	Greenhouse Gas
GIP	Generator Interconnection Procedure
GMC	Grid Management Charge
GPI	Gas Price Index
GRDT	Generator Resource Data Template
GUI	Graphical User Interface

 California ISO	Technology	Template Version:	6.8
		Document Version:	4.6 1.7
Extended Day Ahead Market Business Requirements Specification - Planning		Date Created:	1/21/2026

Acronym	Definition
H	Hour
HASP	Hour-Ahead Scheduling Process
HAVGC	Heat Average Cost (for non-gas resources)
HR	Heat Rate
ICE	InterContinental Exchange
ICM	Infrastructure Contracts and Management
ID	Identifier
IFM	Integrated Forward Market
ISL	Intertie Scheduling Limit
ISO	California Independent System Operator
IOOC	Integrated Optimal Outage Coordination
IR	Imbalance Reserve
IRD	Imbalance Reserve Down
IRU	Imbalance Reserve Up
IT	Information Technology
ITC	Inter-Tie Constraint
ITPD	Information Technology Product Development
ITS	Interchange Transaction Scheduler
ITSM	Information Technology Service Management
JOU	Joint Owned Unit
LACA	Look-Ahead Contingency Analysis
LAP	Load Aggregation Point

 California ISO	Technology	Template Version:	6.8
		Document Version:	4.6 1.7
Extended Day Ahead Market Business Requirements Specification - Planning		Date Created:	1/21/2026

Acronym	Definition
LDF	Load Distribution Factor
LEL	Lower Economic Limit
LFR	Lower Forbidden Region
LF	Load Forecast
LFZ	Load Forecast Zone
LMP	Locational Marginal Price
LMPM	Locational Market Power Mitigation
LOL	Lower Operating Limit
LPT	Low Price Taker (low priority)
LRA	<i>Local Regulatory Authority</i>
LRL	Lower Regulation Limit
LSE	Load Serving Entity
LTCA	Long-Term Contingency Analysis
MCI	Model and Contract Implementation
MD	Manual Dispatch
MDT	Minimum Down Time
MDS	Maximum Daily Startups
MEC	Marginal Energy (Cost) Component
MES	Market Engineering Services
MF	Master File
MF2SOA	Master File to Service-Oriented Architecture
MGC	Marginal Gas Cost

 California ISO	Technology	Template Version:	6.8
		Document Version:	6.1.7
Extended Day Ahead Market Business Requirements Specification - Planning		Date Created:	1/21/2026

Acronym	Definition
MLAC	Minimum Load Average Cost
MLC	Minimum Load Cost
MLHAVGC	Minimum Load Heat Average Cost (for non-gas resources)
MLHR	Minimum Load Heat Rate
MMA	Major Maintenance Adder
MMAMLC	Major Maintenance Adder for Minimum Load Cost
MMASUC	Major Maintenance Adder for Start Up Cost
MMASTC	Major Maintenance Adder for MSG State Transition Cost
MMG	Manage Markets & Grid
MMR	Manage Market & Reliability
MOS	Manage Operations Support & Settlements
MPM	market Power Mitigation
MPP	Market Participant Portal
MQS	Market Quality System
MRID	Master Resource Identifier
MRI-S	Market Results Interface – Settlements
MSSA	Metered Sub System Agreement
MSG	Multi-Stage Generator
MSR	Mirror System Resource
MUT	Minimum Up Time
MV&A	Market Validation & Analysis
MVT	Market Validation Tool

 California ISO	Technology	Template Version:	6.8
		Document Version:	6.8 1.7
Extended Day Ahead Market Business Requirements Specification - Planning		Date Created:	1/21/2026

Acronym	Definition
N/A	Not Applicable
NA	Network Application
NDAB	Negotiated Default Availability Bid
NDEB	Negotiated Default Energy Bid
NGR	Non-Generating Resource
NM	Network Model
NPM	Nodal Price Model
NQC	Net Qualifying Capacity
NSI	Net Scheduled Interchange
OASIS	Open Access Same-time information System
OATI	Open Access Technology International
OATT	Open Access Transmission Tariff
OC	Opportunity Cost
OCC	Opportunity Cost Calculator
ODCP	On Demand Capacity Procurement
OES	Operations Engineering Services
OMS	Outage Management System
OOM	Out Of Market
OTS	Operations Training Simulator
PAM	Program and Application Management
PBC	Power Balance Constraint
PC	Pre-Calculation

 California ISO	Technology	Template Version:	6.8
		Document Version:	4.6 1.7
Extended Day Ahead Market Business Requirements Specification - Planning		Date Created:	1/21/2026

Acronym	Definition
PCA	Price Correction Admin
PCT	Price Correction Tools
PDR	Proxy Demand Resource
PHY	Physical Trade
PI	Plant Information
PL	Participating Load
Pmax	Maximum Generation Capacity
Pmin	Minimum Generation Capacity
PMO	Program Management Office
PNM	Public New Mexico
Pnode	Pricing Node
POC	Point Of Contact
PRSC	Participating Resource Scheduling Coordinator
PSH	Pump Storage Hydro
PSTD	Power Systems Technology Development
PSTO	Power Systems Technology Operations
PT	Price Taker (high priority)
PTO	Participating Transmission Owner
PTP	Point to Point Transmission Service
QRB	Quality Review Board
RA	Resource Adequacy
RC	Reliability Coordinator (or Reliability Capacity up and down-depending on context)

 California ISO	Technology	Template Version:	6.8
		Document Version:	4.6 1.7
Extended Day Ahead Market Business Requirements Specification - Planning		Date Created:	1/21/2026

Acronym	Definition
RC-BSAP	Reliability Coordinator - Base Schedule Aggregation Portal
RCD	Reliability Capacity Down
RCSA	Reliability Coordinator Service Agreement
RCU	Reliability Capacity Up
RDOT	Ramping Dispatch Operating Target (a continuous piecewise linear curve connecting consecutive <i>DOTs</i> using their mid-interval points, from RTD, RTCD, or RTDD runs, as applicable)
RDRR	Reliability Demand Response Resource
RDT	Resource Data Template
REG	Regulation
REGD	Regulation Down
REGU	Regulation Up
REN	Reliability Energy
RES	Resource
RIG	Remote Intelligent Gateway
RIMS	Resource Interconnection Management System
RMR	Reliability Must Run
ROPR	Operating Reserve Ramp Rate
RR	Ramp Rate
RREG	Regulation Ramp Rate
RSE	Resource Sufficiency Evaluation
RSEE	Resource Sufficiency Evaluation Enhancements
RT	Real-Time

 California ISO	Technology	Template Version:	6.8
		Document Version:	4.6 1.7
Extended Day Ahead Market Business Requirements Specification - Planning		Date Created:	1/21/2026

Acronym	Definition
RTBS	Real-Time Base Scheduler
RTCA	Real-Time Contingency Analysis
RTCD	Real-Time Contingency Dispatch
RTD	Real-Time Dispatch
RTDD	Real-Time Disturbance Dispatch
RTECON	Real-Time Economic
RTLPT	Real-Time Low Price Taker (low priority)
RTPD	Real-Time Pre-Dispatch
RTPT	Real-Time Price Taker (high priority)
RTM	Real-Time Market
RTMO	Real-Time Market Operator
RTUC	Real-Time Unit Commitment
RUC	Residual Unit Commitment
SADS	System And Design Specifications
SC	Scheduling Coordinator
SCID	Scheduling Coordinator Identifier
SCME	Scheduling Coordinator Meter Entity
SDGAP	Super Default Generation Aggregation Point
SE	State Estimator
SIBR	Scheduling Infrastructure and Business Rules
SME	Subject Matter Expert
SOA	Service-Oriented Architecture

 California ISO	Technology	Template Version:	6.8
		Document Version:	4.6 1.7
Extended Day Ahead Market Business Requirements Specification - Planning		Date Created:	1/21/2026

Acronym	Definition
SP	Scheduling Point
SQMD	Settlements Quality Meter Data
SR	System Resource
SRS	System Requirement Specifications
SS	Self-Schedule
STC	State Transition Cost
STF	Short-Term Forecast
STC	State Transition Cost
STT	State Transition Time
STUC	Short-Term Unit Commitment
SUC	Start Up Cost
SUE	Start Up Energy
SUF	Start Up Fuel
SURT	Start Up Ramp Time
SUT	Start Up Time
T	Time/Trading Hour
TBD	To Be Determined
TD	Trade Day/Date
TEE	Total Expected Energy
TEP	Tucson Electric Power
TG	Tie Generator
TH	Trading Hub

 California ISO	Technology	Template Version:	6.8
		Document Version:	4.6 1.7
Extended Day Ahead Market Business Requirements Specification - Planning		Date Created:	1/21/2026

Acronym	Definition
TNA	Transmission Network Application
TOP	Transmission Operator Provider
TOPA	Transmission Operator Provider Area
TOR	Transmission Ownership Rights
TR	Transmission Registry
TSR	Transfer System Resource
TTEE	Total Target Expected Energy (based on RDOT)
UAT	User Acceptance Testing
UEL	Upper Economic Limit
UFE	Unaccounted for Energy
UFR	Upper Forbidden Region
UI	User Interface
UIE	Uninstructed Energy Imbalance
UL	User Limited
UOL	Upper Operating Limit
URL	Upper Regulation Limit
VER	Variable Energy Resource
VOM	Variable Operations & Maintenance
VOMC	Variable Operations & Maintenance Cost
WebOMS	Web-based Outage Management System
WEIM	Western Energy Imbalance Market
XML	Extensible Markup Language

 California ISO	Technology	Template Version:	6.8
		Document Version:	4.6 1.7
Extended Day Ahead Market Business Requirements Specification - Planning		Date Created:	1/21/2026

Acronym	Definition
XSD	XML Schema Definition
ZIL	Zero Impedance Line

 California ISO	Technology	Template Version:	6.8
		Document Version:	4.6 1.7
Extended Day Ahead Market Business Requirements Specification - Planning		Date Created:	1/21/2026

Appendix A1

This section is intentionally left blank.

Appendix A2

This section is intentionally left blank.

Appendix A3

This section is intentionally left blank.

Appendix A4

This section is intentionally left blank.

Appendix A5

This section is intentionally left blank.

Appendix A6

This section is intentionally left blank.

 California ISO	Technology	Template Version:	6.8
		Document Version:	6.1.7 1.7
Extended Day Ahead Market Business Requirements Specification - Planning		Date Created:	1/21/2026

Appendix A7: Transmission right (ETC/TOR/OATT) sales examples

TRANSMISSION RIGHT OWNER (TRO) registered 100MW CRN is CRN_TRO_000 with TSR ids CRN_TRO_TSR_SOURCE_000 and CRN_TRO_TSR_SINK_000 (and the other transfer at Node). At 7am TRO sells 20MW to Buyer1. TRO will coordinate with EDAM_ENTITY so that EDAM_ENTITY submits the following CRN definition in SIBR, preferably by 9am:

CRN_TRO_001

Entitlement: 20 MW

Resource Ids: BUYER1_IMPORT_SR_SOURCE and BUYER1_EXPORT_SR_EDAM_ENTITY under the Buyer1 SC (these should be registered in MF)

TSR Ids: CRN_TRO_TSR_SOURCE_001 and CRN_TRO_TSR_SINK_001 (and the other transfer at Node) under the Buyer1 SC

Buyer1 submits 20MW self-schedule at the source/sink resources and the TSRs by 10am.

At 8:30am, TRO sells 50MW to Buyer2. TRO will coordinate with EDAM_ENTITY (the EDAM Entity) so that EDAM_ENTITY submits the following CRN definition in SIBR, preferably by 9am:

CRN_TRO_002

Entitlement: 50 MW

Resource Ids: BUYER2_IMPORT_SR_SOURCE and BUYER2_EXPORT_SR_EDAM_ENTITY under the Buyer2 SC (these should be registered in MF)

TSR Ids: CRN_TRO_TSR_SOURCE_002 and CRN_TRO_TSR_SINK_002 (and the other transfer at Tesla) under the Buyer2 SC

Buyer2 submits 50MW self-schedule at the source/sink resources and the TSRs by 10am.

At 8:55am (no more sales after 9am), TRO releases 10MW of CRN_TRO_000 to EDAM to receive transfer revenue (pathway 2). The remaining unused 20MW rights may be released by EDAM_ENTITY under the EDAM_ENTITY TSRs by 10am (pathway 3) or left unused for RTM.

Actor	TRANSMISSION RIGHT OWNER (TRO) TRO SC	EDAM_ENTITY(EDAMENT) EDAMENT SC	Buyer1 Buyer1 SC	Buyer2 Buyer2 SC
--------------	--	--	---------------------------------------	---------------------------------------

 California ISO	Technology	Template Version:	6.8
		Document Version:	6.1.7
Extended Day Ahead Market Business Requirements Specification - Planning		Date Created:	1/21/2026

MF register resource	100MW CRN: CRN_TRO_000 TRO SC TSR ids: CRN_TRO_TSR_SOURCE_000 CRN_TRO_TSR_SINK_000	EDAMENT SC TSR id: EDAMENT_TSR_SOURCE_001 EDAMENT_TSR_SINK_001	Buyer1 SC Import/export resource ids: BUYER1_IMPORT_SR_SOURCE BUYER1_EXPORT_SR_EDAMENT	Buyer2 SC Import/export resource ids: BUYER2_IMPORT_SR_SOURCE BUYER2_EXPORT_SR_EDAMENTAssociate
Sale 1 at 7 am	Sale 20 MW CRN: CRN_TRO_001	Submit in SIBR by 9 am: CRN_TRO_001 for 20 MW CRN Dynamic create TSR ids and associate CRN_TRO_001 with following under buyer1: CRN_TRO_TSR_SOURCE_001 CRN_TRO_TSR_SINK_001 BUYER1_IMPORT_SR_SOURCE BUYER1_EXPORT_SR_EDAMENT	Submit in SIBR by 10 am Self-schedule 20 MW for: CRN_TRO_TSR_SOURCE_001 CRN_TRO_TSR_SINK_001 BUYER1_IMPORT_SR_SOURCE BUYER1_EXPORT_SR_EDAMENT	
Sale 2 at 8:30 am	Sale 50 MW CRN: CRN_TRO_002	Submit in SIBR by 9 am: CRN_TRO_002 for 50 MW CRN Dynamic create TSR ids and associate CRN_TRO_002 with following under buyer2: CRN_TRO_TSR_SOURCE_002 CRN_TRO_TSR_SINK_002 BUYER2_IMPORT_SR_SOURCE BUYER2_EXPORT_SR_EDAMENT		Submit in SIBR by 10 am Self-schedule 50 MW for: CRN_TRO_TSR_SOURCE_002 CRN_TRO_TSR_SINK_002 BUYER2_IMPORT_SR_SOURCE BUYER2_EXPORT_SR_EDAMENT

 California ISO	Technology	Template Version:	6.8
		Document Version:	4.6 1.7
Extended Day Ahead Market Business Requirements Specification - Planning		Date Created:	1/21/2026

Pathway 2 release	Release 10 MW CRN to market by 9 am Submit TSR limits 10 MW in SIBR, deemed as pathway 2 CRN_TRO_TSR_SOURCE_000 CRN_TRO_TSR_SINK_000			
Pathway 3 release		Submit in SIBR by 10 am EDAMENT SC submit TSR limits up to 20 MW for market EDAMENT_TSR_SOURCE_001 EDAMENT_TSR_SINK_001		
Late-schedule		Submit Self-schedule for TRO SC up to 20 MW through RTSI after 10 am until to TH-75min CRN_TRO_TSR_SOURCE_000 CRN_TRO_TSR_SINK_000		

 California ISO	Technology	Template Version:	6.8
		Document Version:	4.6 1.7
Extended Day Ahead Market Business Requirements Specification - Planning		Date Created:	1/21/2026

Appendix A8: EDAM Access Charge Illustrative Example

The following example illustrates each mechanism of the EDAM access charge, including an example of a new transmission service provider joining EDAM. The example is intended only to illustrate how the EDAM access charge would work year to year. It is not intended to estimate projected values for actual prospective EDAM entities. The CAISO used arbitrary values for each figure.

The EDAM access charge is comprised of three components: (1) certain historical transmission revenues, (2) new network upgrade costs that increase EDAM transfer capability, and (3) revenues from wheeling-through transfers exceeding the transmission service provider's imports and exports.

The example begins with four (4) different EDAM balancing authority areas (BAA). The example assumes each EDAM entity begins participation at the outset of the EDAM in 2026. Table 1 illustrates their historical 3-year average of EDAM recoverable revenue.

Table 1: Historical 3-year Average of EDAM Recoverable Revenue

EDAM Entity transmission provider	Historical 3-year average of short-term transmission sales (for 2026) ¹
BAA 1	\$14,242,500
BAA 2	\$3,600,000
BAA 3	\$4,750,000
BAA 4	\$30,700,000

In EDAM, transmission providers will continue operating their Open Access Transmission Tariffs (OATT) and selling short-term transmission products². Thus, a portion of the historical 3-year average of short-term transmission sales under Table 1 is revenue at risk. Each entity will forecast the amount of expected revenue for the particular year, as illustrated in Table 2.

Table 2: Projected Eligible Recoverable Revenue for Component 1 for 2026

¹ In this example, assuming an EDAM launch of 2026, the 3-year historical average of short term transmission sales is derived based on the average of sales for years 2023, 2024, and 2025.

² The CAISO BAA-equivalents to short-term sales are exports and wheeling-through transactions that would be charged the wheeling access rate. For purposes of simplicity, this example does not distinguish between the CAISO BAA and its participating transmission owners under the CAISO tariff and an EDAM balancing area with transmission service providers operating under an OATT.

 California ISO	Technology	Template Version:	6.8
		Document Version:	6.1.7
Extended Day Ahead Market Business Requirements Specification - Planning		Date Created:	1/21/2026

EDAM Entity transmission provider	Historical 3-year average of short-term transmission sales	Component 1: Projected EDAM recoverable revenue
BAA 1	\$14,242,500	\$7,121,250
BAA 2	\$3,600,00	\$1,116,000
BAA 3	\$4,750,000	\$1,187,500
BAA 4	\$30,700,000	\$1,615,000

The CAISO’s example assumes some EDAM entities may build new network upgrades increasing EDAM transfer capacity. Some of these costs would be eligible for recovery in component 2. To determine eligible costs for component 2, each EDAM entity would compute its ratio of (a) the non-firm and short-term firm point-to-point historical EDAM recoverable transmission revenues to (b) the EDAM transmission owner’s total revenue requirement. The ratio serves as a proxy for determining the extent to which any new network upgrades benefit the larger EDAM footprint. Thus, the EDAM entity only recovers new network upgrade costs up to a percentage based on the ratio.

Table 3: Ratio of Short-term Sales to Total Transmission Revenue Requirement

EDAM Entity Transmission Provider	Historical 3-year average of short-term transmission sales	Historical 3-year average of annual transmission revenue requirement	Component 2 ratio
BAA 1	\$14,242,500	\$158,250,000	9.0%
BAA 2	\$3,600,000	\$125,000,000	2.88%
BAA 3	\$4,750,000	\$218,500,000	2.17%
BAA 4	\$30,700,000	\$585,350,000	2.49%

Assume that starting with year 2027, BAA 3 has a new network upgrade eligible for recovery through component 2 of the EDAM access charge. Assume the total approved amount for recovery for the upgrade is \$11,000,000. BAA 3 would multiply this cost by its component 2 ratio to derive the upper limit of the new eligible network upgrades EDAM recoverable costs.

 California ISO	Technology	Template Version:	6.8
		Document Version:	6.1.7
Extended Day Ahead Market Business Requirements Specification - Planning		Date Created:	1/21/2026

Table 4: Computation of Component 2 for BAA 3

EDAM Entity transmission provider	New eligible network upgrade cost (part of annual revenue requirement) (a)	Ratio (%) of short-term revenues for new network upgrades (b)	Component 2: New eligible network upgrades EDAM recoverable costs limit (c) = (a) * (b)	Component 2: Estimate of EDAM recoverable amount for new eligible network upgrades for 2027 (d)
BAA 3	\$11,000,000	2.17%	\$238,700	\$59,000

Component 3 of the EDAM access charge accounts for benefits to EDAM from transmission used for wheeling-throughs in an EDAM BAA greater than its imports and exports. In this example, the excess wheeling-through transfer is calculated for the relevant trade year (2026) and added as a recoverable cost for the following trade year (2027) for the BAA with the transmission facilitating the wheeling-throughs. As illustrated in Table 5, assume BAA 1 has 10,000 MWh in wheeling-through transfers above its total import and export transfers, and a non-firm hourly point-to-point transmission rate of \$5/MWh.

Table 5: Computation of Component 3

EDAM Entity transmission provider	Net incremental wheeling-through transfer volumes (2026)	Non-firm hourly point-to-point rate	Compensation at the hourly non-firm OATT rate ³ (recovered in 2027)
BAA 1	10,000 MWh	\$5/MWh	\$50,000
BAA 2	0		0
BAA 3	0		0
BAA 4	0		0

EDAM Access Charge Assessment and Distribution

³ For simplicity purposes, all twelve months of the year with excess wheeling-throughs have been summed to reflect the total annual cost rather than showing all twelve months individually as component 3 provides.

 California ISO	Technology	Template Version:	6.8
		Document Version:	6.1.7
Extended Day Ahead Market Business Requirements Specification - Planning		Date Created:	1/21/2026

Using the sum of the components for each EDAM entity, the CAISO will compute a \$/MWh rate specific to each EDAM BAA. To form the numerator of the rate, the CAISO will divide each EDAM entity's aggregate revenue to the EDAM BAAs associated with the other EDAM transmission entities by (a) the EDAM entity's gross load divided by (b) the total EDAM area gross load minus the gross load of the EDAM entity. The BAA-specific EDAM access charge rate is then applied to the current year actual gross load.

As a starting point, Table 6 illustrates the EDAM recoverable revenue that is recoverable through EDAM for 2026 where the only recoverable revenues were associated with component 1 (and reflected in Table 2). Table 6 also identifies each BAA's annual gross load.

Table 6: 2026 EDAM Recoverable Revenue and Gross Load

EDAM Entity transmission provider	EDAM recoverable revenue	Gross load (MWh)
BAA 1	\$7,121,250	35,800,000
BAA 2	\$1,116,000	15,850,000
BAA 3	\$1,187,500	70,750,000
BAA 4	\$1,615,000	109,000,000

The EDAM recoverable revenue is distributed across the BAAs on a load ratio share basis as shown in Table 7 to derive a BAA-specific EDAM access charge rate.⁴ A BAA is not allocated its own revenue through the EDAM access charge.

⁴ Each BAA's EDAM recoverable revenue is allocated based on the gross load ratio share to the other BAAs, excluding itself. In the example, BAA 1's EDAM recoverable revenue of \$7,121,250 million is allocated to BAAs 2, 3, and 4 in proportion to their respective load ratio share (excluding the gross load of BAA 1).

 California ISO	Technology	Template Version:	6.8
		Document Version:	4.61.7
Extended Day Ahead Market Business Requirements Specification - Planning		Date Created:	1/21/2026

Table 7: BAA-specific Allocation of EDAM Access Charge

EDAM Entity transmission provider	BAA 1 – gross load	BAA 2 – gross load	BAA 3 – gross load	BAA 4 – gross load	EDAM access rate total gross load
BAA 1	-	15,850,000	70,750,000	109,000,000	195,600,000
BAA 2	35,800,000	-	70,750,000	109,000,000	215,550,000
BAA 3	35,800,000	15,850,000	-	109,000,000	160,650,000
BAA 4	35,800,000	15,850,000	70,750,000	-	122,400,000

EDAM Entity transmission provider	BAA 1 – EDAM recoverable revenue allocation	BAA 2 – EDAM recoverable revenue allocation	BAA 3 – EDAM recoverable revenue allocation	BAA 4 EDAM recoverable revenue allocation	EDAM recoverable revenue
BAA 1	-	\$577,054	\$2,575,810	\$3,968,386	\$7,121,250
BAA 2	\$185,353	-	\$366,305	\$564,342	\$1,116,000
BAA 3	\$264,628	\$117,161	-	\$805,711	\$1,187,500
BAA 4	\$472,361	\$209,132	\$933,507	-	\$1,615,000
BAA total allocation	\$922,342	\$903,347	\$3,875,622	\$5,338,439	\$11,039,750

These allocations are then further converted to an EDAM access charge rate for each BAA as shown in Table 8. The CAISO divides the total cost allocation for the BAA by its annual gross load.

 California ISO	Technology	Template Version:	6.8
		Document Version:	6.1.7
Extended Day Ahead Market Business Requirements Specification - Planning		Date Created:	1/21/2026

Table 8: Derivation of EDAM Access Charge Rate

EDAM Entity transmission provider	Total cost allocation to the BAA	Annual gross load (MWh)	EDAM access charge rate assessed to the BAA
BAA 1	\$922,342	35,800,000	\$0.026 per MWh
BAA 2	\$903,347	15,850,000	\$0.057 per MWh
BAA 3	\$3,875,622	70,750,000	\$0.055 per MWh
BAA 4	\$5,338,439	109,000,000	\$0.049 per MWh

The BAA-specific EDAM access charge rate is then applied to each BAA's actual gross load and settled on a monthly basis. Table 9 illustrates the assessment of the EDAM access charge by BAA for 2026.

Table 9: Collection of EDAM Access Charge through 2026

EDAM Entity transmission provider	Actual annual gross load (MWh)	EDAM access charge rate ⁵	EDAM access charge assessed
BAA 1	36,740,463	\$0.026 per MWh	\$950,000
BAA 2	15,489,158	\$0.057 per MWh	\$886,000
BAA 3	71,997,353	\$0.055 per MWh	\$3,960,000
BAA 4	106,056,667	\$0.049 per MWh	\$5,210,000

Table 10 illustrates the distribution of BAA-specific EDAM access charge revenue in pro-rata of the BAA total allocation of EDAM recoverable revenue to the BAA-specific allocation of EDAM recoverable revenue as derived in Table 7.

Table 10: Distribution of EDAM Access Charge Collected Revenues (2026)

⁵ To avoid differences due to granularity the rate has been rounded up.

 California ISO	Technology	Template Version:	6.8
		Document Version:	4.6 1.7
Extended Day Ahead Market Business Requirements Specification - Planning		Date Created:	1/21/2026

EDAM Entity transmission provider	BAA 1 – specific allocation	BAA 2 – specific allocation	BAA 3 – specific allocation	BAA 4 – specific allocation	BAA EDAM access charge revenue
BAA 1	-	\$565,942	\$2,630,637	\$3,875,095	\$7,071,674
BAA 2	\$190,820	-	\$373,934	\$550,828	\$1,115,582
BAA 3	\$271,622	\$114,511	-	\$784,077	\$1,170,210
BAA 4	\$487,558	\$205,546	\$955,430	-	\$1,648,534

Annual True-Up of EDAM Recoverable Revenue

The EDAM access charge includes an annual true-up to help right-size the EDAM access charge year to year based on expected collections and actual collections. Critically, the annual true-up also corrects any inaccurate projections based on actual collections each year.

Table 11 identifies the different sources of short-term revenues for 2026. For purposes of the example, assume the EDAM recoverable revenue estimated by the BAAs in Table 2 consists of the actual EDAM access charge amounts recovered by the CAISO and distributed to the BAA in 2026. Because there were no component 2 and 3 revenues considered for the year 2026, the true up example in Table 9 reflects true-up only to component 1.

 California ISO	Technology	Template Version:	6.8
		Document Version:	6.1.7
Extended Day Ahead Market Business Requirements Specification - Planning		Date Created:	1/21/2026

Table 11: True-up of Component 1 Based on 2026 Actuals

EDAM Entity transmission provider	Historical 3-year average of short term sales (e)	Revenues recovered through EDAM access charge (f)	Net incremental wheel through transfers (g)	Adjusted EDAM access charge revenue (h) = (f – g)	EDAM Entity’s actual OATT sales of short-term products (i)	True-up amount for 2027 EDAM access charge (j) = (f +i) – (e)
BAA 1	\$14,242,500	\$7,071,674	-	\$7,071,674	\$7,170,826	\$0
BAA 2	\$3,600,000	\$1,115,582	-	\$1,115,582	\$1,484,418	(\$1,000,000)
BAA 3	\$4,750,000	\$1,170,210	-	\$1,170,210	\$4,079,790	\$500,000
BAA 4	\$30,700,000	\$1,648,534	-	\$1,648,534	\$29,051,466	\$0

In Table 11, BAA 1 and BAA 4 recovered between the EDAM access charge revenues and their actual OATT sales of short-term products the exact amounts to cover their historical 3-year averages of short-term sales. As such, no true-up is necessary. However, BAA 2 under-recovered \$1,000,000, and BAA 3 over-recovered \$500,000. These amounts for BAA 2 and BAA 3 will be carried forward into the 2027 EDAM access charge.

Table 12 illustrates how the true-up and components 2 and 3 will comprise the EDAM access charge for 2027.

 California ISO	Technology	Template Version:	6.8
		Document Version:	4.6 1.7
Extended Day Ahead Market Business Requirements Specification - Planning		Date Created:	1/21/2026

Table 12: 2027 EDAM Access Charge Inputs.

EDAM Entity transmission provider	Historical 3-year average of short-term sales	New network upgrades	Net incremental wheeling-through transfers	True-up from 2026	Costs to be Recovered through OATT and EDAM
BAA 1	\$14,242,500	\$0	\$50,000	-	\$14,292,500
BAA 2	\$3,600,000	\$0	\$0	\$1,000,000	\$4,600,000
BAA 3	\$4,750,000	\$238,700	\$0	(\$500,000)	\$4,488,700
BAA 4	\$30,700,000	\$0	\$0	-	\$30,700,000

As shown in Table 12, going into 2027, the CAISO will calculate the total recoverable EDAM revenues across the components to which each EDAM entity (*i.e.*, BAA) ultimately will be true-up. BAA 1 continues to carry its historical 3-year average plus the component 3 revenues captured in Table 5. BAA 2, because it did not have any component 2 or 3 amounts, carries over its component 1 revenues into 2027 adjusted by the 2026 true-up under-recovery. BAA 3 carries component 1 and component 2 illustrated in Table 4 into 2027, adjusted by the over-recovery in the 2026 true up. BAA 4 continues to carry over component 1 into 2027 as there are no additional components applicable for the year.

Finally, having established the total recoverable amounts for 2027, the CAISO will need to calculate the total 2027 projected EDAM access charge recoverable amount for each BAA as the sum of each component EDAM recoverable amount, which is the difference shown in Table 13 between the components of EDAM recoverable revenue and what the BAA expects to collect through eligible OATT sales in 2027.

Table 13: 2027 EDAM Access Charge Recovery Calculation

EDAM Entity transmission provider	Estimate of historical EDAM recovery for 2027	Estimate of new network upgrades EDAM recoverable revenue for 2027	Net incremental wheeling-through transfers	2026 True-up (over or under recovery)	Estimated EDAM recoverable revenue (for 2027)
BAA 1	\$7,125,000	-	\$50,000	-	\$7,175,000
BAA 2	\$1,100,000	-	-	\$1,000,000	\$2,100,000

 California ISO	Technology	Template Version:	6.8
		Document Version:	4.6 1.7
Extended Day Ahead Market Business Requirements Specification - Planning		Date Created:	1/21/2026

BAA 3	\$1,100,000	\$59,000	-	(\$500,000)	\$659,000
BAA 4	\$1,600,000	-	-	-	\$1,600,000



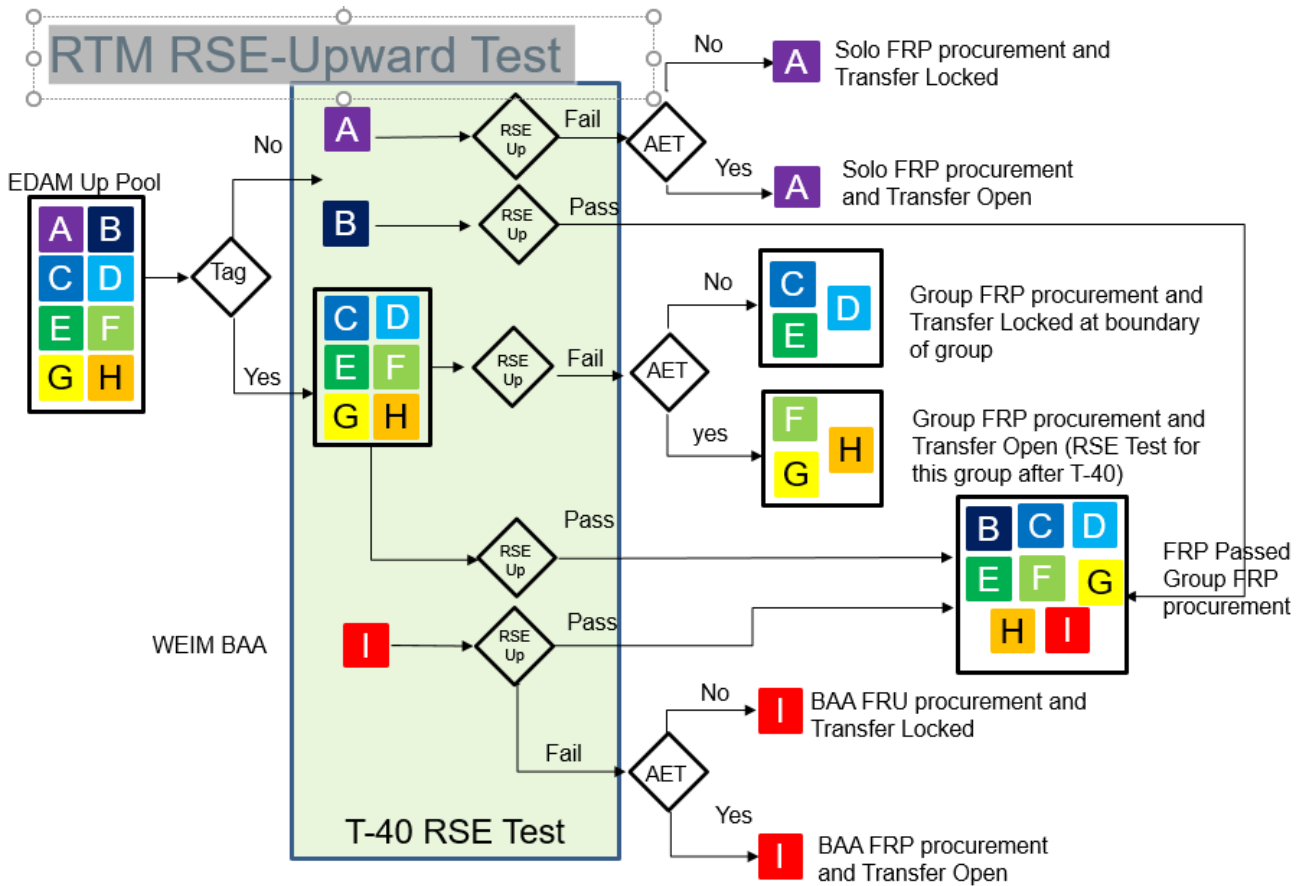

Appendix A9: Business Flow Diagrams



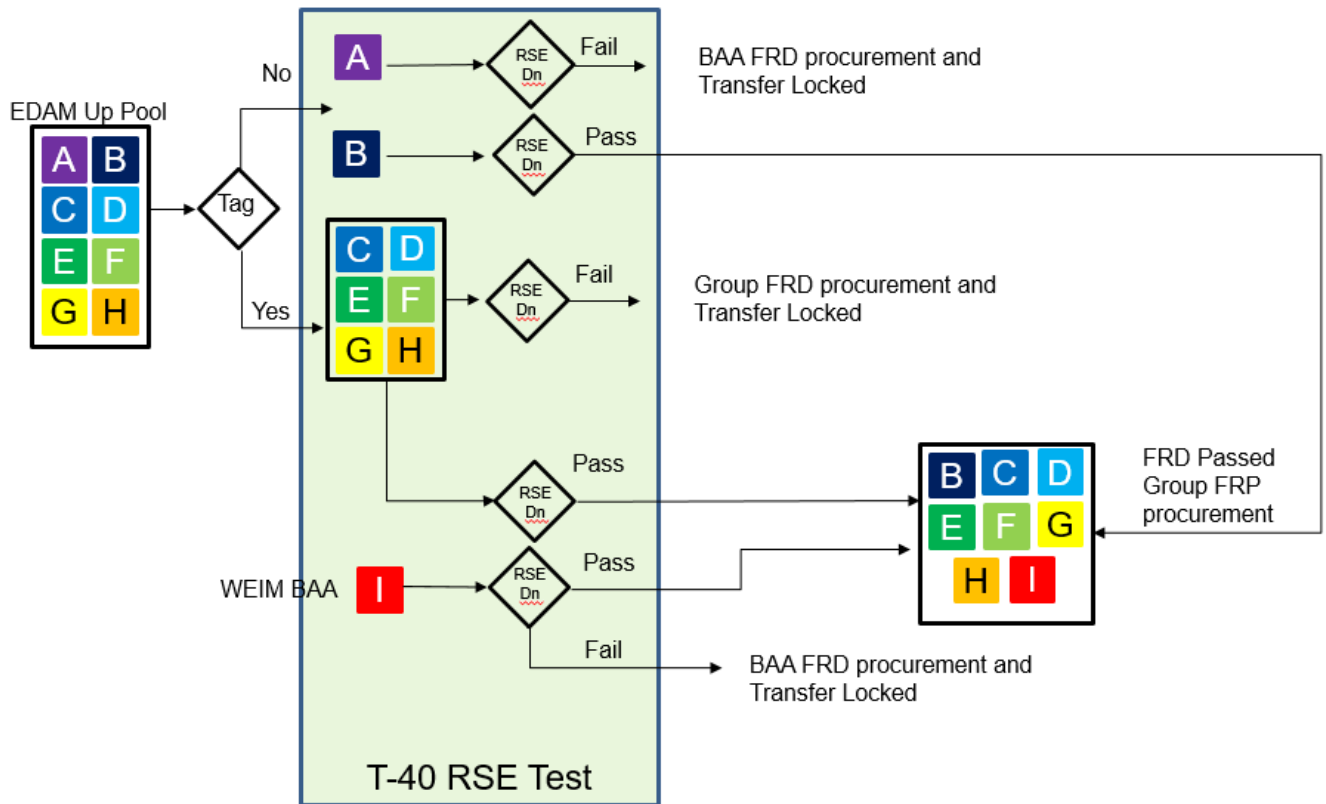

RTM RSE Downward Test



 California ISO	Technology	Template Version:	6.8
		Document Version:	4.6 1.7
Extended Day Ahead Market Business Requirements Specification - Planning		Date Created:	1/21/2026

Appendix A10

This section is intentionally left blank.

Appendix A11

This section is intentionally left blank.

Appendix A12

This section is intentionally left blank.

 California ISO	Technology	Template Version:	6.8
		Document Version:	6.1.7
Extended Day Ahead Market Business Requirements Specification - Planning		Date Created:	1/21/2026

Appendix A13: TSR Glossary of Terms

EDAM Entity Scheduling Coordinator (EESC)	The scheduling coordinator (SC) that represents the EDAM Entity (BAA) participating in the EDAM
Transmission Customer Scheduling Coordinator (TCSC)	The SC that represents the transmission customer within a BAA participating in the EDAM.
Transfer System Resources (TSRs)	<p>Logical resources used in the EDAM to model the export from one BAA and the import to another BAA. Each transfer is modelled as a matching pair of export or import Transfer System Resources (TSRs) at a Transfer Location between EDAM BAAs</p> <p>Note: ETSR is used for WEIM, and TSR is used for EDAM</p>
Transfer Location	A uniquely identified intertie that is registered in the MF to support TSRs, both registered in the MF and transient TSRs defined in SIBR. The Transfer Location definition includes the from BAA, to BAA, Intertie ID, transfer direction, Transfer Revenue Distribution Factors, and BAA responsible for submitting the tag for the transfer. TCSCs may submit Released Capacity bids at Transfer Locations for CRNs.
TSR Type 1	<p>Bilateral energy transactions between Transmission Customers (TCs) that exercise their physical, and financial, if applicable, transfer rights at a transfer location. To maintain their physical rights (higher scheduling priority) afforded by the CRN, self-schedules under a CRN must be balanced and within the CRN Entitlement in each BAA. SCs retain the financial right (transmission congestion/loss hedge from supply to demand and/or TSR export, or from TSR import and/or supply to demand) for the balanced portion, as applicable. Irrespective of the scheduling priority, self-schedules are RSE-eligible.</p>
TSR Type 2	<p>Capacity from TCs that release their transfer rights on at a transfer location. There are two ways to define Type 2 TSRs:</p> <ol style="list-style-type: none"> 1. The EESC on each side of the transfer location defines the TSR for the relevant TC in the Master File. Then, the TCSC may release its transfer rights on the respective TSR. The TCSCs may be the same for both TSRs in the pair, or they may be different, but the released transfer capacities must be equal, otherwise, SIBR will select the lower of the two values. 2. Alternatively, the EESC on each side of the transfer location may submit in SIBR the list of TCs and associated capacity release.

 California ISO	Technology	Template Version:	6.8
		Document Version:	4.6 1.7
Extended Day Ahead Market Business Requirements Specification - Planning		Date Created:	1/21/2026

	<p>SIBR will then match TCs and capacity released at the transfer location and the matching Transfer Location on the other side. SIBR will then define TSR pairs for each match and for each Trading Hour of the Trading Day, and will notify the respective TCSCs and EESCs. TCSCs may not take any further action. The TCSC for the TSR with capacity released before 9:00am is eligible to receive 50% of the transfer revenue (unless a different ratio is specified in the Master File by Transfer Location and corresponding Matching Transfer Location) on that transfer directly from the Market Operator (MO).</p>
TSR Type 3	<p>RSE-eligible transfer capacity released by EDAM Entities. The EESC at each Transfer Location defines the TSR for itself in the Master File. Then, the EESC may self-provide ancillary services (regulation up and down, spinning, and non-spinning reserve) and release transfer capacity on the respective TSR. The ancillary services self-provisions and released transfer capacities must be equal across the transfer location, otherwise SIBR will select the lower of the two values.</p>
TSR Type 4	<p>Non-RSE-eligible transfer capacity released by EDAM Entities. The EESC must define at the Transfer Location the TSR for itself in the Master File. Then, the EESC may release transfer capacity on the respective TSR. The released transfer capacities must be equal across the transfer location, otherwise SIBR will select the lower of the two values.</p>
Transient TSR	<p>A TSR pair that is not registered in the Master File (MF), rather it is defined in the Scheduling Infrastructure and Business Rules (SIBR) system for a specific Trading Day.</p>
Contract Reference Number (CRN)	<p>A unique identification of a transmission contract in the MF that can be exercised by its rights holder by self-scheduling at resources, including TSRs and Transfer Locations, as sources and sinks that can be in multiple BAAs.</p>
Generic CRN (“NONE”)	<p>The “NONE” key word for a CRN_ID is used to indicate that there is no transmission contract at that Transfer Location for a TSR Type 1, and it is used to accommodate existing CRN validation rules that require a CRN. SIBR does not perform balancing/entitlement validation for this CRN. The “NONE” CRN has no financial or physical rights.</p>
“CISO” SC	<p>The EESC for CISO BAA used for TSRs at a CISO Transfer Location when there is no specific TCSC for that TSR.</p>
Tag Flag	<p>The Transfer Location attribute defined in MF used to define the BAA as the primary authority responsible for submitting tags on a TSR and schedule changes in RTSI. One and only one BAA from the TSR pair can have the flag set to yes.</p>

 California ISO	Technology	Template Version:	6.8
		Document Version:	4.6 1.7
Extended Day Ahead Market Business Requirements Specification - Planning		Date Created:	1/21/2026

Transfer Revenue Distribution Factor (RDF)	The factor that defines how Transfer Revenue is divided between the two BAAs of a TSR pair.
Transfer Cost	The coefficient value assigned in the DAM to each TSR type to represent the relative schedule priority of the different TSR types in the market optimization (also used for ETSRs in the WEIM).
CRN Entitlement Capacity	The total transmission right for a transmission contract (CRN).
CRN Capacity	The total capacity allocated from a CRN Entitlement at a specific Transfer Location.
Maximum Capacity	The Maximum Capacity for a TSR.
Released Capacity	Capacity released to EDAM at a specific Transfer Location by a TCSC out of its allotted CRN Capacity for TSR Type 2.