



California ISO

DAME, EDAM, EDAM CAISO BAA PR Market Sim & Parallel Ops Meeting

March 30, 2025

ISO PUBLIC

COPYRIGHT © 2026 BY CALIFORNIA INDEPENDENT SYSTEM OPERATOR. ALL RIGHTS RESERVED.

Agenda

Monday

- Customer Experience Updates
- Market Validation and Analysis Overview
- Q&A

Thursday

- Customer Experience Updates
- Phase 3 Status
- Upcoming STAGE Outage
- Market Validation and Analysis Overview
- Additional Issues Tracking
- Q&A

DAME, EDAM, EDAM ISO BAA Meetings

Monday 9-10AM PT, and Thursday 1-2PM PT

	Monday	Tuesday	Wednesday	Thursday	Friday
February	2	3	4	5	6
	9	10	11	12	13
	16	17	18	19	20
	23	24	25	26	27
March	2	3	4	5	6
	9	10	11	12	13
	16	17	18	19	20
	23	24	25	26	27
	30	31	28	29	30

Market Sim & Parallel Ops Meeting

ISO Closure

Cancelled

[Calendar | California ISO](#)

DAME / EDAM / WEIM – Timeline

Initiative	Connectivity Testing	Integration Testing	Structured Market Sim	Unstructured Market Sim	Parallel Operations	Activation
<u>Day-Ahead Market Enhancements</u>	06/02/25 – 09/01/25	06/02/25 – 09/01/25	09/02/25 – 12/01/25	12/01/25 – 01/30/26	02/02/26 – 04/30/26	05/01/26
<u>Extended Day-Ahead Market</u>	06/02/25 – 09/01/25	06/02/25 – 09/01/25	09/02/25 – 12/01/25	12/01/25 – 01/30/26	02/02/26 – 04/30/26	05/01/26
<u>EDAM ISO BAA Participation Rules Track A</u>	06/02/25 – 09/01/25	06/02/25 – 09/01/25	09/02/25 – 12/01/25	12/01/25 – 01/30/26	02/02/26 – 04/30/26	05/01/26
<u>Extended Day-Ahead Market On-Boarding - Pacificorp</u>	05/01/25 – 05/31/25	06/02/25 – 09/01/25	09/02/25 – 12/01/25	12/01/25 – 01/30/26	02/02/26 – 04/30/26	05/01/26
<u>Extended Day-Ahead Market - PGE</u>	11/01/25 – 11/30/25	12/01/25 – 03/01/26	03/01/26 – 05/30/26	03/01/26 – 05/30/26	06/01/26 – 09/15/26	10/01/26
<u>WEIM – Power Watch</u>	09/01/25 – 10/17/25	10/01/26 – 11/30/26	12/01/25 – 01/30/26	NA	02/16/26 – 04/30/26	05/06/26
<u>WEIM – Black Hills</u>	09/01/25 – 10/17/25	10/01/26 – 11/30/26	12/01/25 – 01/30/26	NA	02/16/26 – 04/30/26	05/06/26

Note: dates reflected here refer to the start and end dates around testing, specific Trade Dates relevant for testing and validations can be found in the [Settlements Calendar](#) posted to Release page on CAISO.com.

Inquiry Stats

General:

- **584** cases created since the start of Parallel Operations
 - **417** closed/resolved
- SC Participation continues to be strong
- Black Hills and Power Watch onboarding going well
- PacifiCorp onboarding going well – Phase 3 (Real-Time)
 - It is integral for participants to remain fully engaged in real-time operations **by submitting real-time economic bids.**
- **Trending Cases:**
- GHG Inquiries
 - Prices & Results: Market team continues to investigate and will update tickets accordingly. As well as provide updates on these calls holistically
- Imbalance Reserve and Reliability Capacity
 - Prices & Results: Market team continues to investigate and will update tickets accordingly

Upcoming Environment/Application Outages

STAGE:

- **Start:** After 12:00 AM PT on **Wednesday, March 25, 2026**
 - **End:** 11:59 PM PT on **Sunday, March 29, 2026**
 - **Stabilization:** **Monday, March 30, 2026**
- During this time, the Stage environment, for all systems will be **unavailable or not fully integrated**. While some applications may appear to come online earlier, full upstream/downstream data flow will **not function** until stabilization is complete.
 - We will provide a **confirmation email** once the environment is restored and will also confirm status during the **March 30 Parallel Operations call**.
 - See next slide for overview of impact on applications and processes

[Maintenance Outage Schedule](#)

MSS-016

Scenario Number	Structured scenario	
16	Name	DA RA Obligation Reassignment
	Market	DAM
	Description	Demonstrate Reassignment of RA Obligation
	Market Operator Actions	N/A
	EDAM Market Participant Actions	<ul style="list-style-type: none"> • RA suppliers define SR (for Generic RA) and TGs (for Flex and Generic RA) in MF to support month-ahead RA showings for RA imports • RA supplier SC submits RA obligation reassignments in CIRA by 8 am for DA to ensure obligation transfer functions and RAAIM settlements are correctly assessed <ul style="list-style-type: none"> ○ For RA sourced from EDAM BAA: submit RA obligation reassignment to physical resources by 8 am ○ DA reassignment carries over to RT • SC submits (in SIBR) DA bids on resources/SRs with DA RA obligation • SC submits (in SIBR) RT bids on resources with RT RA obligation
	Expected Outcome	SIBR UI/API: Validate submissions CIRA UI: <ul style="list-style-type: none"> • New DAME/EDAM Tab (being added) CMRI: <ul style="list-style-type: none"> • N/A for directly assessing RA reassignment OASIS: <ul style="list-style-type: none"> • N/A N/A for directly assessing RA reassignment
	Anticipated Settlement Outcome	Settlements to assess RAAIM based on RA obligation reassignment and bid submission status

Bid Seeding Updates

- The ISO team identified the following items while reviewing anomalies within the bid seeding script and bids should be much more comparable for TD 3/20 forward.

Import Bidding Delta

- Internal certificate access
 - Issue has been addressed
- Integration layer issue
 - Issue has been addressed
- Scheduling Coordinators actively removing bids
 - This activity is within participants' rights and aligned with their testing scenarios

NGR Bidding Delta

- Self-schedules combined with RC bids resulting in invalid bids in SIBR
 - Specific Rule 22008 has been identified
 - Issue has been addressed

Interim Manual Workaround

- As a temporary measure, the team is reviewing data sets at 09:30 to help clean up bids in advance of the 10:00 a.m. close.

System Load and Resource Schedules Report

System Load and Resource Schedules								
Market	Opr Date	TAC Name	Interval	Schedule	HE01	HE02	HE03	
DAM	03/19/2026	Caiso_Totals	0	Export	1,079.00	1,078.00	977.00	
DAM	03/19/2026	Caiso_Totals	0	Import	7,517.44	7,421.49	7,456.85	
DAM	03/19/2026	Caiso_Totals	0	Generation	15,523.42	14,346.74	12,988.28	
DAM	03/19/2026	Caiso_Totals	0	Load	23,619.54	22,474.62	21,508.22	

- **CAISO_TOTALS** = NONTAC + TAC_ECNTNTR + TAC_NCNTR + TAC_NORTH + TAC_SOUTH + TAC_SUNZIA
- **EDAM Transfer** values are NOT represented in this report

Testing Request to Community

What

- The Siemens Architecture Framework (SAF) has been upgraded in the Market-Sim (MAPSTAGE) environment

Ask

- The ISO request externals, particularly those using **lower-version B2B services** (e.g., submitRawBidSet_v3, v4), to begin submitting, retrieving, and validating services
- Please report any issues or anomalies observed during this validation via CIDI

Why

- Early validation with older B2B service versions helps rule out SAF-related issues
- This ensures readiness ahead of the planned SAF cutover, which is targeted **prior to EDAM go-live**
 - **Expected date to be communicated**
- Proactive testing supports a smoother transition and minimizes risk during EDAM-related activities

Parallel Operations Phases

- **Phase 1:** DA with transfer off, timeline of 2 weeks or till goals are met, with the following goals
 - Focus on the completeness of data by all participants
 - Review Market quality output as compared to production energy profile plan
 - Market review quality and review of results
 - EDAM entity to adjust Type 2 and Type 4 submissions to limit transfers
 - Though the RTM is not the focus, it will run continuously to support settlements. The RTM should generally solve 95% of the intervals (~15 failed RTM intervals).
 - Market post processing (MQS, filling, price cleanup, etc.) runs on Settlement TDs.
- **Phase 2:** DA with transfer on, timeline of 2 weeks or till goals are met, with the following goals:
 - Focus on Market review quality and review of results of DA output.
- **Phase 3 (TD 3/18):** DA transfer with RT, timeline remaining time of PO, with the following goals:
 - Focus on Market review quality and review with focus on DA/RT convergence.
 - Define “cutover dry run” concepts to test as we enter Phase 3

Parallel Operations – Phase 3

- Parallel Operations has officially entered **Phase 3**. We want to thank you again for your engagement and collaboration to date—your continued participation has been instrumental to reaching this milestone!
- With the transition to Phase 3, EDAM results will now flow into the **real-time** markets. As such, it is integral for participants to remain fully engaged in real-time operations by **submitting real-time economic bids**. Doing so **ensures sufficient system flexibility** and supports the fulfillment of associated DAME product obligations, and **ensures the real-time market results** being **produced reflect economic pricing** and are both production-like and operationally feasible.
- **Your active participation during this phase is critical** to validating market performance, identifying potential issues, and maintaining operational reliability as we progress. We greatly appreciate the time, expertise, and commitment you continue to dedicate to Parallel Operations.
- We look forward to your ongoing collaboration as we move through Phase 3 and continue toward a successful transition.

Upcoming Environment/Application Outages

What are the application Impacts?

- Most Stage applications will be **offline** and **not end-to-end functional** from March 25–29.
- **Production** and **MapStage** environments are **not** impacted

What are the Daily Settlements Publication Impacts?

- **Revised Settlements Calendar to be Published**
- **Stage/PO Settlements TD Thursday 3/26 will be missed and made up on TD Wednesday 4/8.**
 - **TD 3/26** Settlement support will be missed, and will be made up on **TD 4/8 (Wednesday)**
 - **TD 3/17: Recalc** will be missed
 - **TD 3/19:** the **Initial** publication changed from 3/26 to 3/24. **Recalc** will be **missed** since recalc submission window is during the outage timeframe
 - **TD 3/24:** the **Initial** publication is changed from 3/31 to 4/3. **Recalc** will be missed since recalc meter submission window is on 3/31 (before 4/3), thus the **Initial** publication will reflect this already

Upcoming Environment/Application Outages

What are the Monthly Settlements Publication Impacts?

- Monthly Recalc 10-Mar - 12-Mar - will be published **on 3/24 instead of 3/25**
- Monthly Recalc 17-Mar - 19-Mar – will be **missed**
- Monthly Initial 24-Mar - 31-Mar – will do Monthly Initial **for TD 3/24 and 3/31**
- (Monthly Initial 02-April - 7-April) changed to (Monthly Initial 02-April - 9-April)
- (Monthly Recalc 02-April - 7-April) changed to (Monthly Recalc 02-April - 9-April)
-

What are the Settlements Invoice Impacts?

- Invoice (Daily Recalc 10-Mar; Daily Recalc 12-Mar; Monthly Recalc 10-Mar - 12-Mar) - will be published **on 3/24 instead of 3/25**
- Invoice (Daily Recalc 17-Mar; Daily Recalc 19-Mar; Monthly Recalc 17-Mar - 19-Mar) – will be **missed**
- Invoice (Daily Initial 24-Mar; Daily Initial 31-Mar; Monthly Initial 24-Mar - 31-Mar) – will do **for TD 3/24 and 3/31**
- Invoice (Daily Initial 02-April; Daily Initial 7-April; Daily Initial 8-April; Daily Initial 9-April ; Monthly Initial 02-April - 9-April)
- Invoice (Daily Recalc 02-April; Daily Recalc 7-April; Daily Recalc 8-April ; Daily Recalc 9-April ;Monthly Recalc 02-April - 9-April)

Upcoming Environment/Application Outages

Why This Outage Is Necessary

- This outage is required to:
 - Maintain timely **critical information security and compliance requirements**
 - Prepare for the corresponding **production maintenance**, which must occur before the summer period to reduce operational and compliance risk.

Why the Timing Changed

- The maintenance window has moved from earlier dates due to:
 - Avoiding conflicts with other **major initiatives**, such as full network model work.
 - Mitigating conflicts with **spring release testing activities**
 - Ensuring Stage remains available for **Production transition** work starting mid-April and required for spring release activation.

Upcoming Environment/Application Outages

IMPORTANT: Actions to Complete Before March 24th

- **Submit Required Data**
- **Please complete all submissions by the end of calendar date March 24** to support faster system stabilization after the outage window
 - **Day-Ahead bids:** Submit for the full seven-day horizon through **TD March 31**.
 - **Real-Time bids:** Submit through **calendar date March 24**
 - **Outages and forecasts:** Submit as far forward as possible to support system stabilization.

Submitting through this window ensures the necessary data is available during the outage and helps accelerate stabilization when Stage comes back online.

Upcoming Environment/Application Outages

IMPORTANT: Actions to Complete Before March 24th Cont...

- **Validate Your Open CIDI Cases**
- If you have Stage/PO CIDI cases marked “**awaiting client response**” or “**resolved pending customer**”, please validate these in Stage **before the outage window**.
- Cached data clean up and data retention policies may limit availability of saved web services data in certain integration layers.
 - **Download Any Data or Reports You Will Need**
- Before the environment goes offline, please download:
 - **Settlement statements** published thru March 24
 - **OASIS/CMRI reports, SIBR data**, or any Stage outputs you plan to review during the outage period
- This ensures you can continue validation work even while Stage is unavailable.

Access Charge Guidance

Parallel Operations:

- EDAM TSPs and CISO PTOs may submit an optional authorized affidavit with Attachment F for Parallel Operations participation by January 23, 2026.
- If not able to submit by January 23rd, submission from MAPSTAGE shall be utilized.
- EDAM Access Charge Rates and recoverable revenue information will be processed and posted by February 1st 2026 and be included in subsequent Parallel Operations Settlements Statements.

Production:

- Unless submitted for Parallel Operations, EDAM TSPs and CISO PTOs must submit the authorized affidavit with Attachment F for Production by April 13th, 2026.
- EDAM Access Charge Rates and Recoverable revenue information will be processed and posted by April 27, 2026, and be included in statements published for TD 5/2 and onward.

Update on missing bids in parallel operations

- A fix for the remaining bid seeding issue was pushed for trade date 3/17
- After this fix was made, 3 new separate issues were identified:
 - An issue with the integration layers was still preventing certain imports from reaching the market
 - Should be resolved for TD 3/20
 - A SIBR defect was identified that was incorrectly disqualifying certain battery bids
 - Working with vendor to fix
 - The 3/17 fix created a new issue which stopped the creation of IR bids for certain resources.
 - Should be resolved for TD 3/20
- Bids can also vary from prod due to re-submittal and the 7-day seeding lag

Prod vs PO bid stack comparison

PO

En Input Bids for CISO

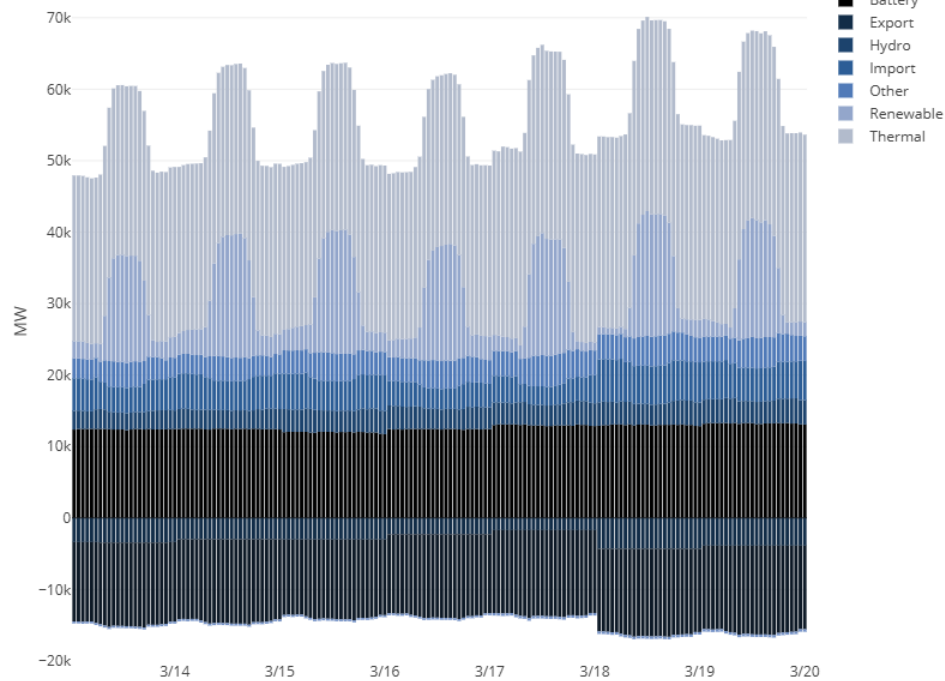

Prod

En Input Bids for CISO

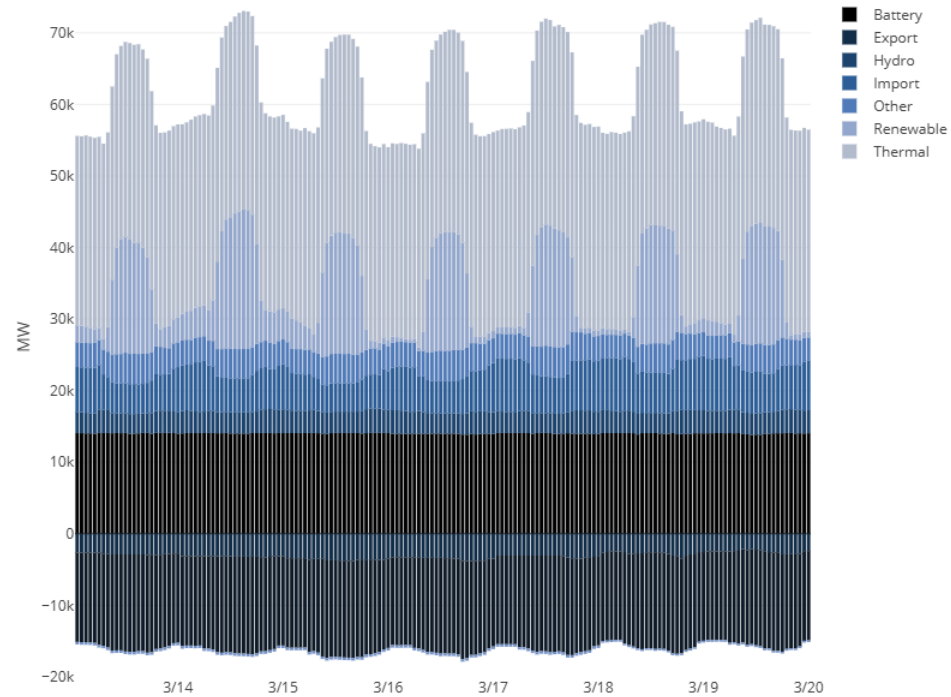

Import and Export bids comparison – PO vs. Prod

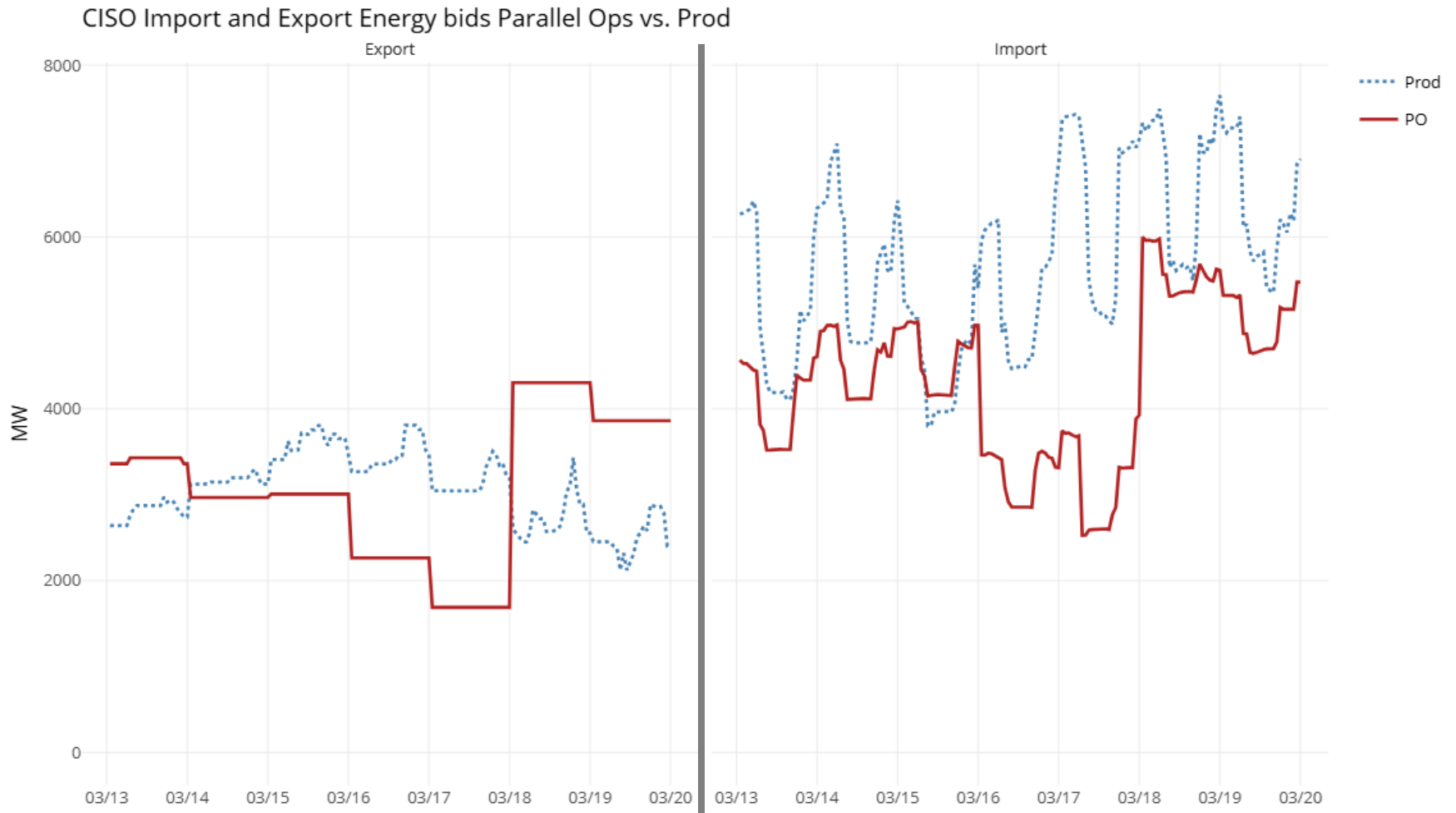

Battery bids comparison – PO vs. Prod

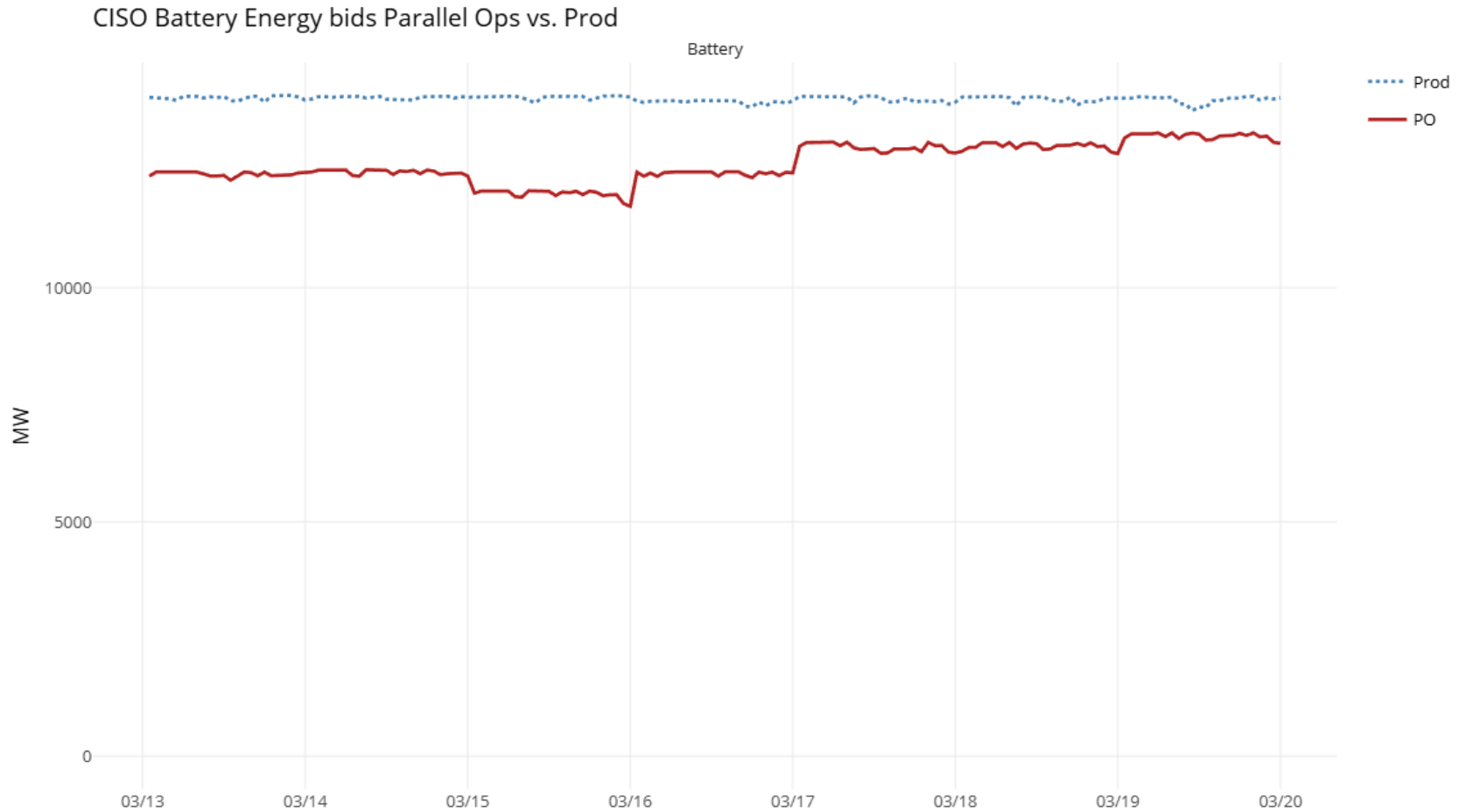

Renewable bids comparison – PO vs. Prod

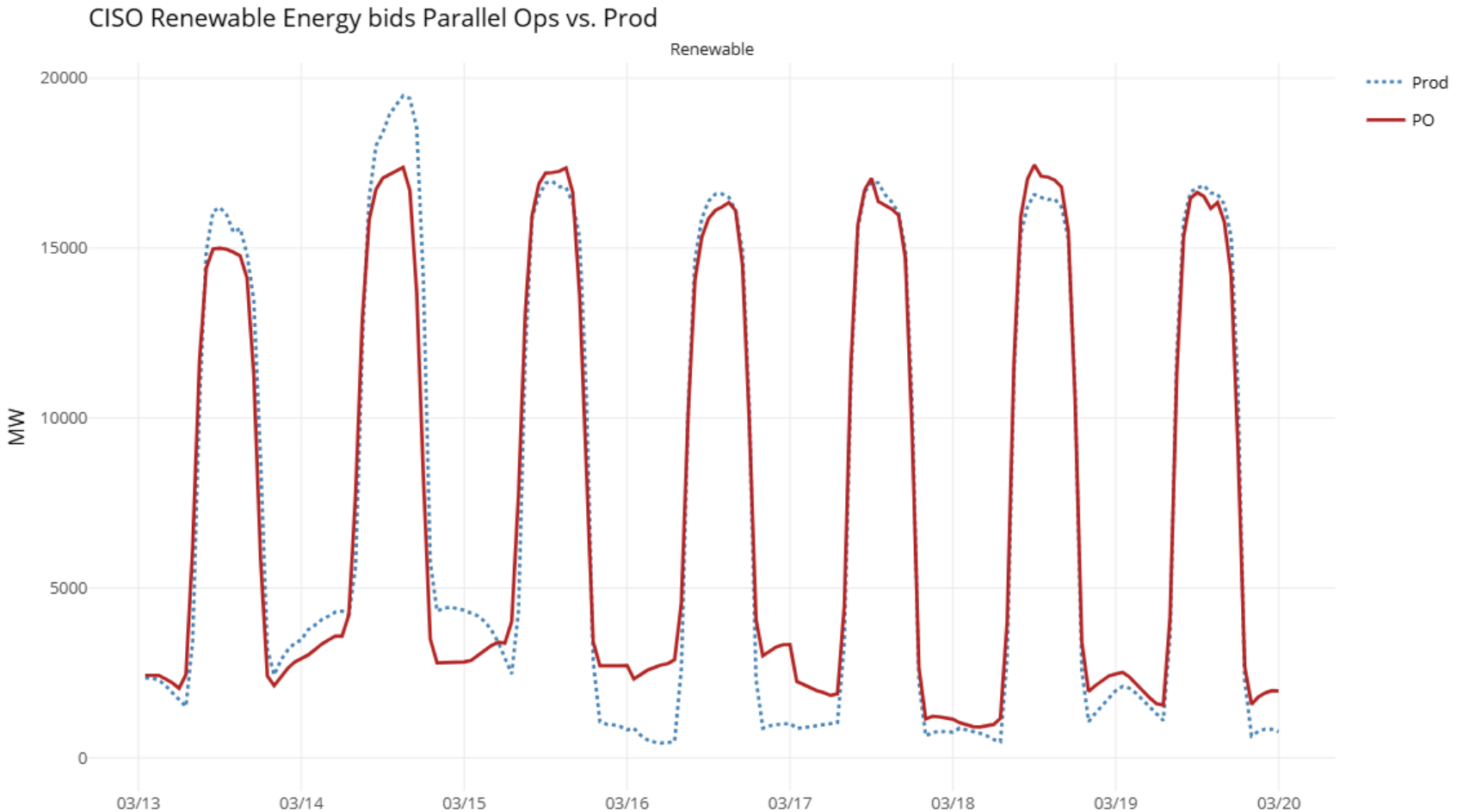

Energy pricing update

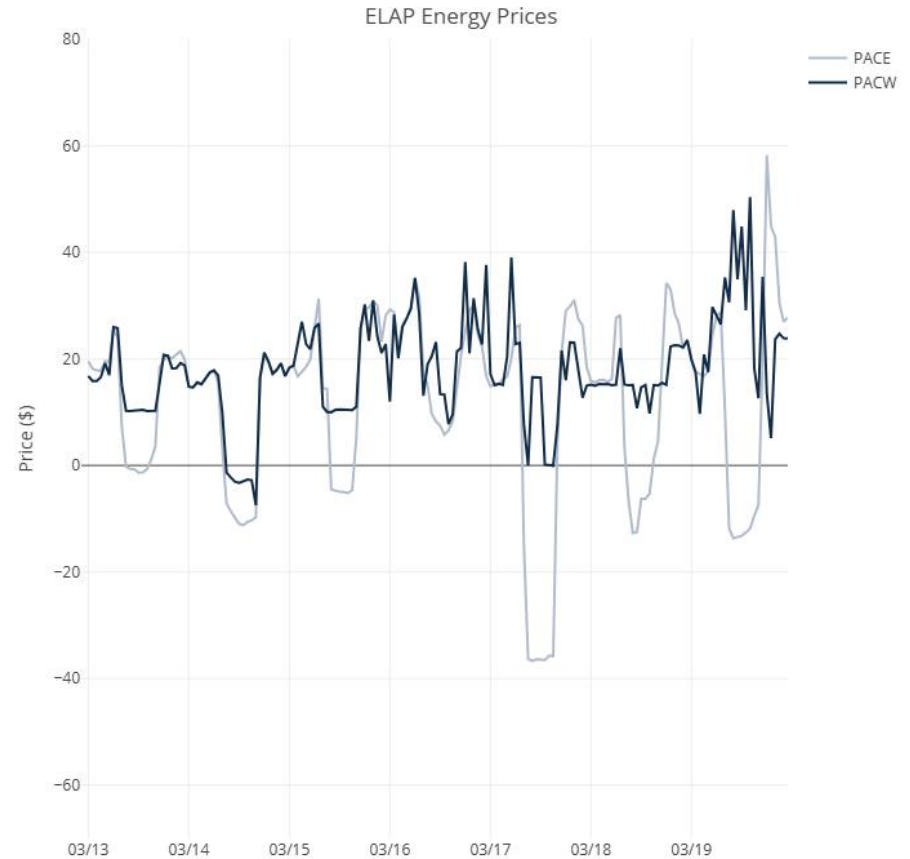
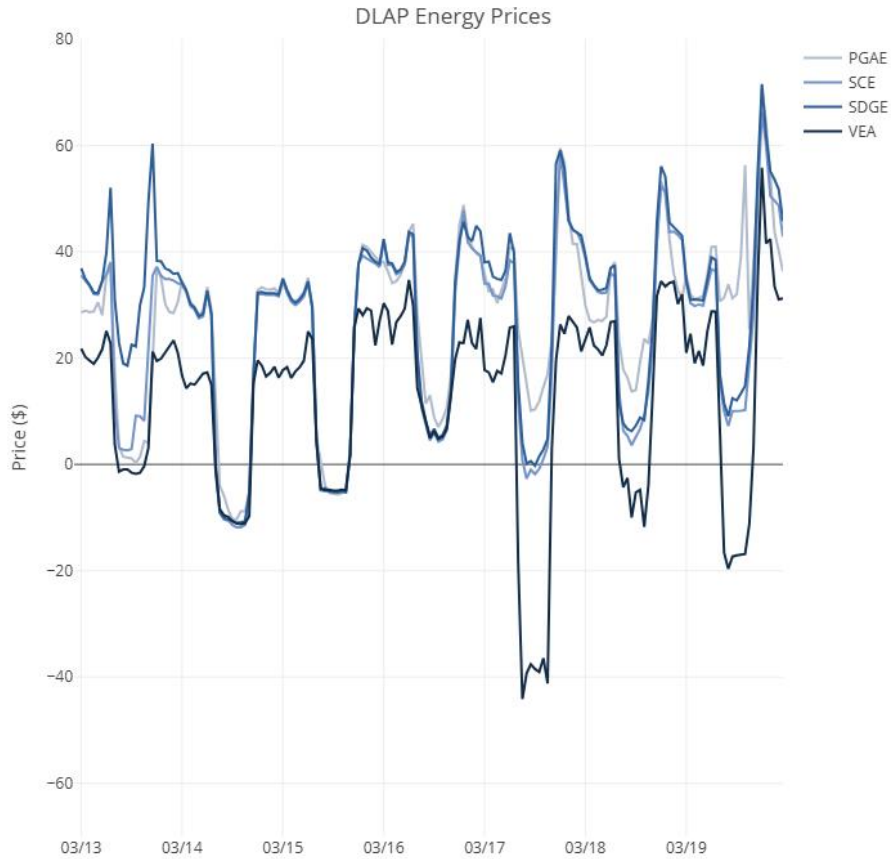

CISO Transfers in IFM

Energy and IR TSR Optimized Transfers for CISO

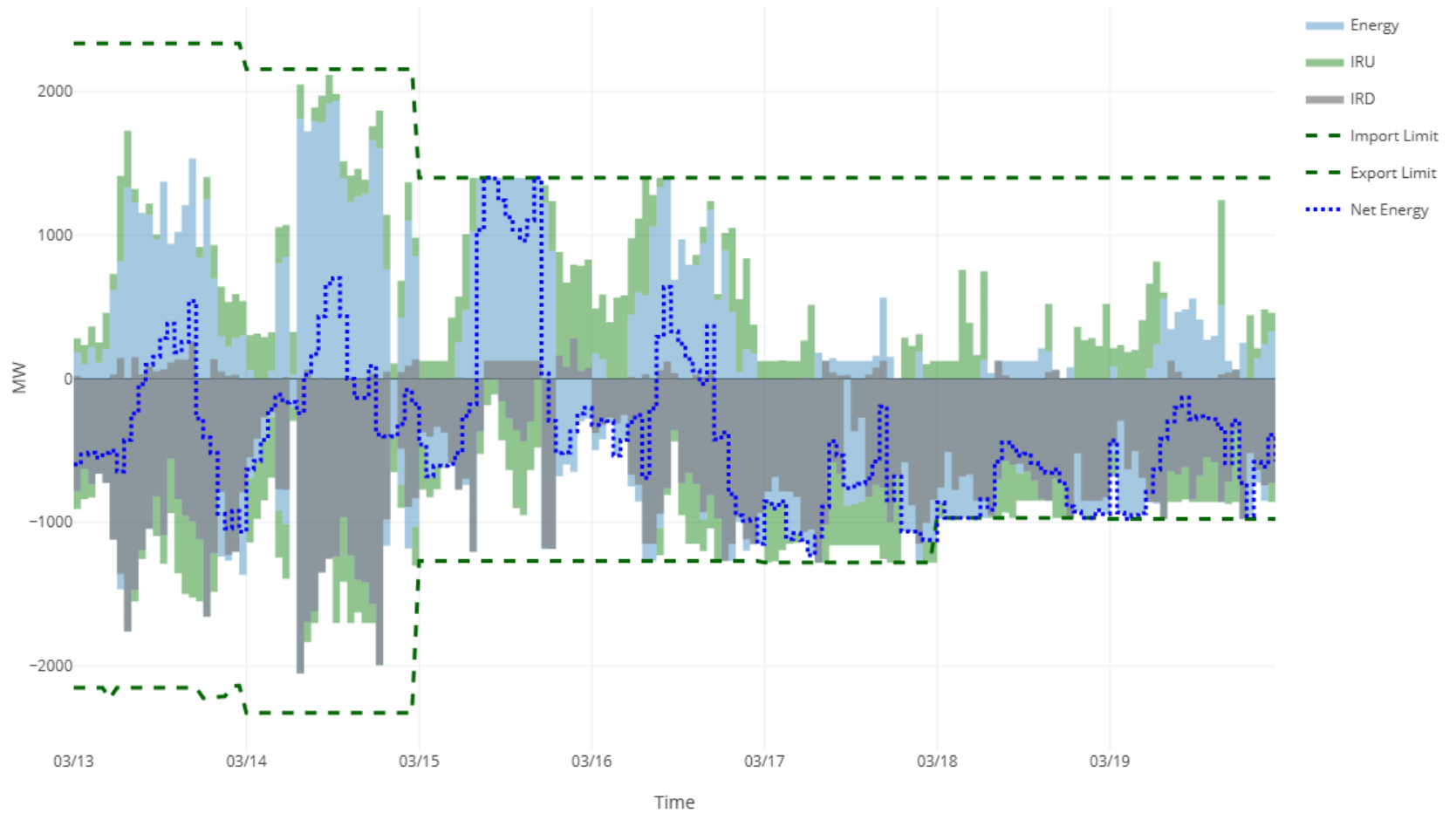

GHG price and net CISO transfers

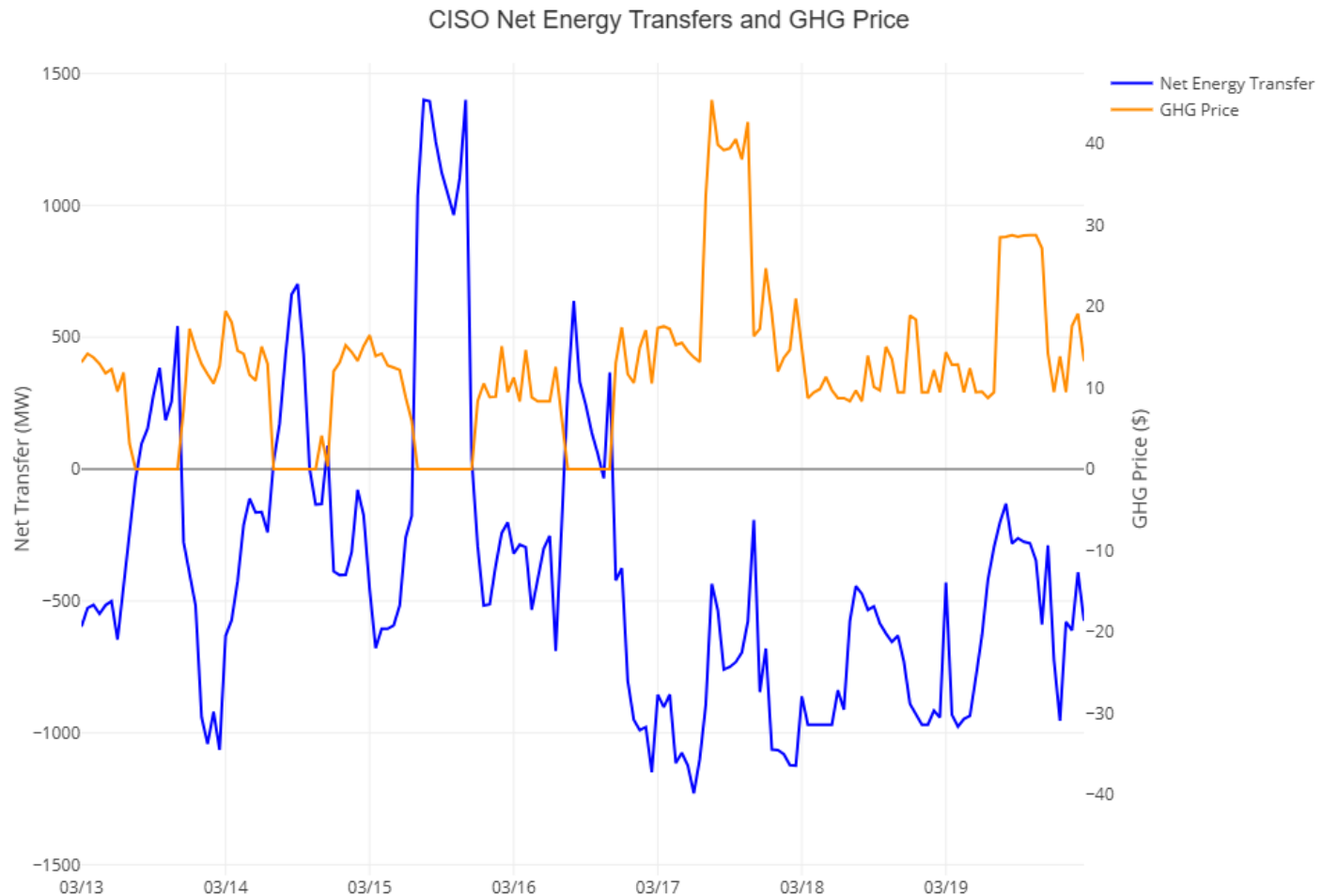

When the transfers are negative (import), we see non-zero GHG price

BAA IRU Prices

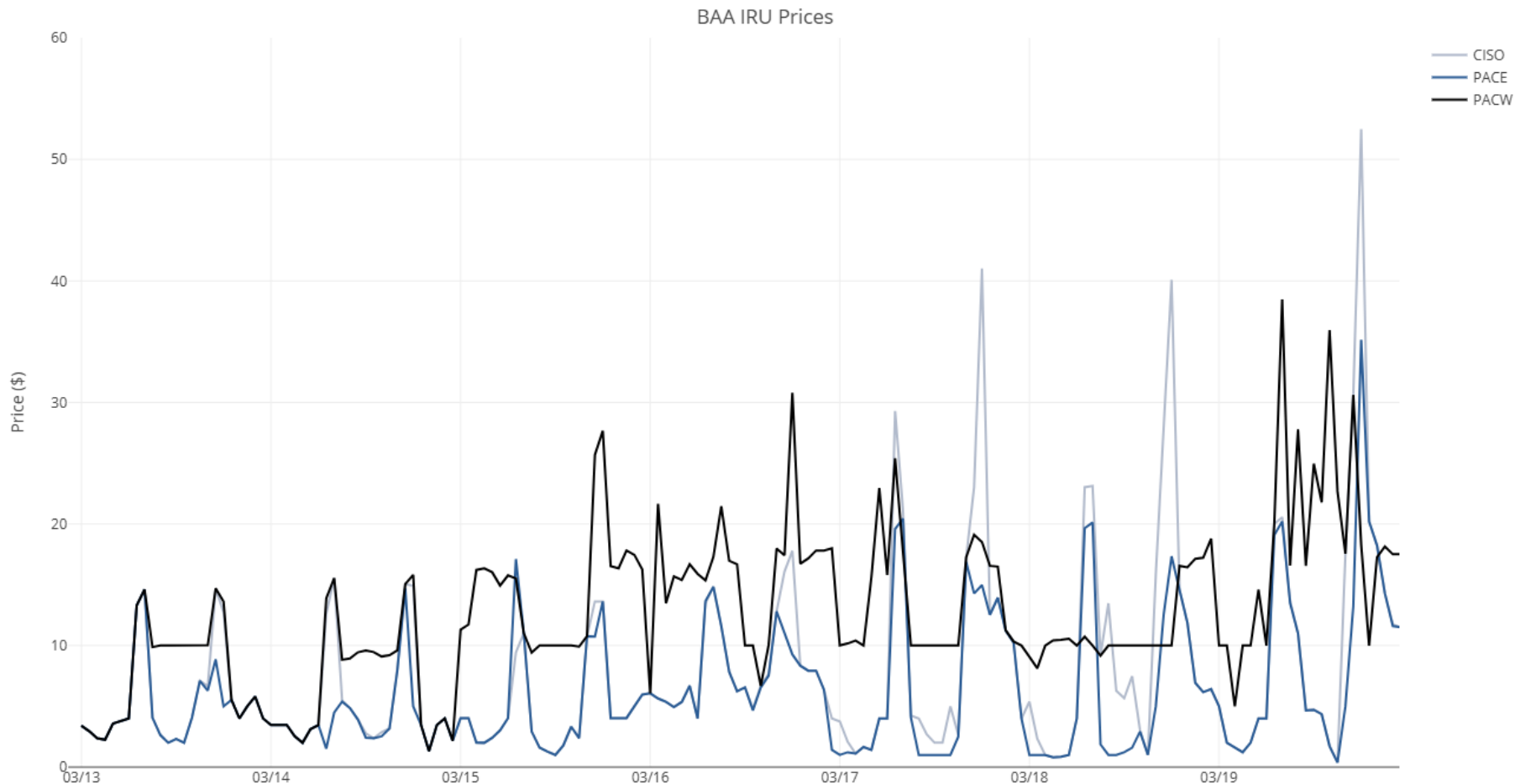

Increased price separation with the more limited transfers

BAA IRD Prices

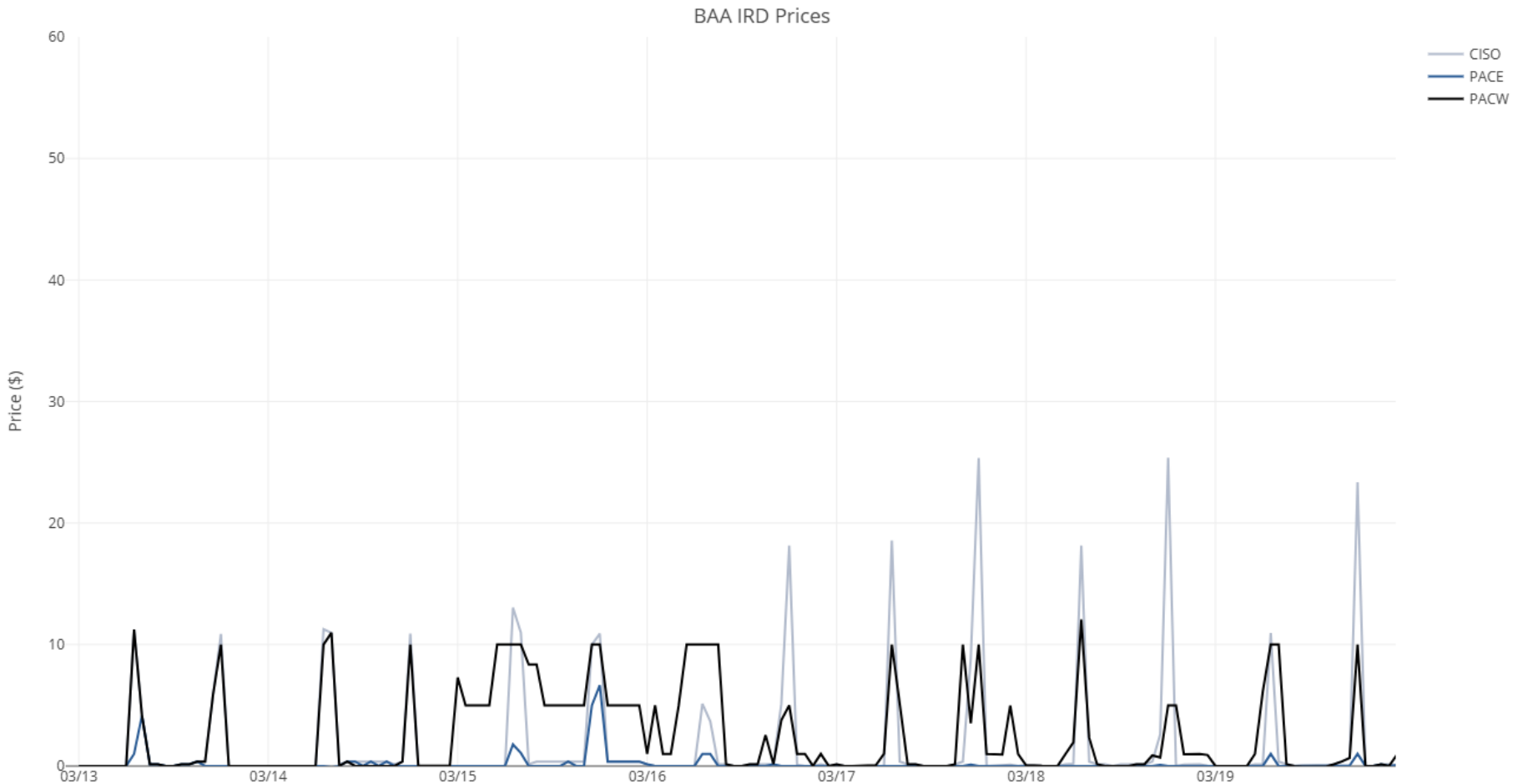

Increased price separation with the more limited transfers

Prod to PO comparison – DLAP prices

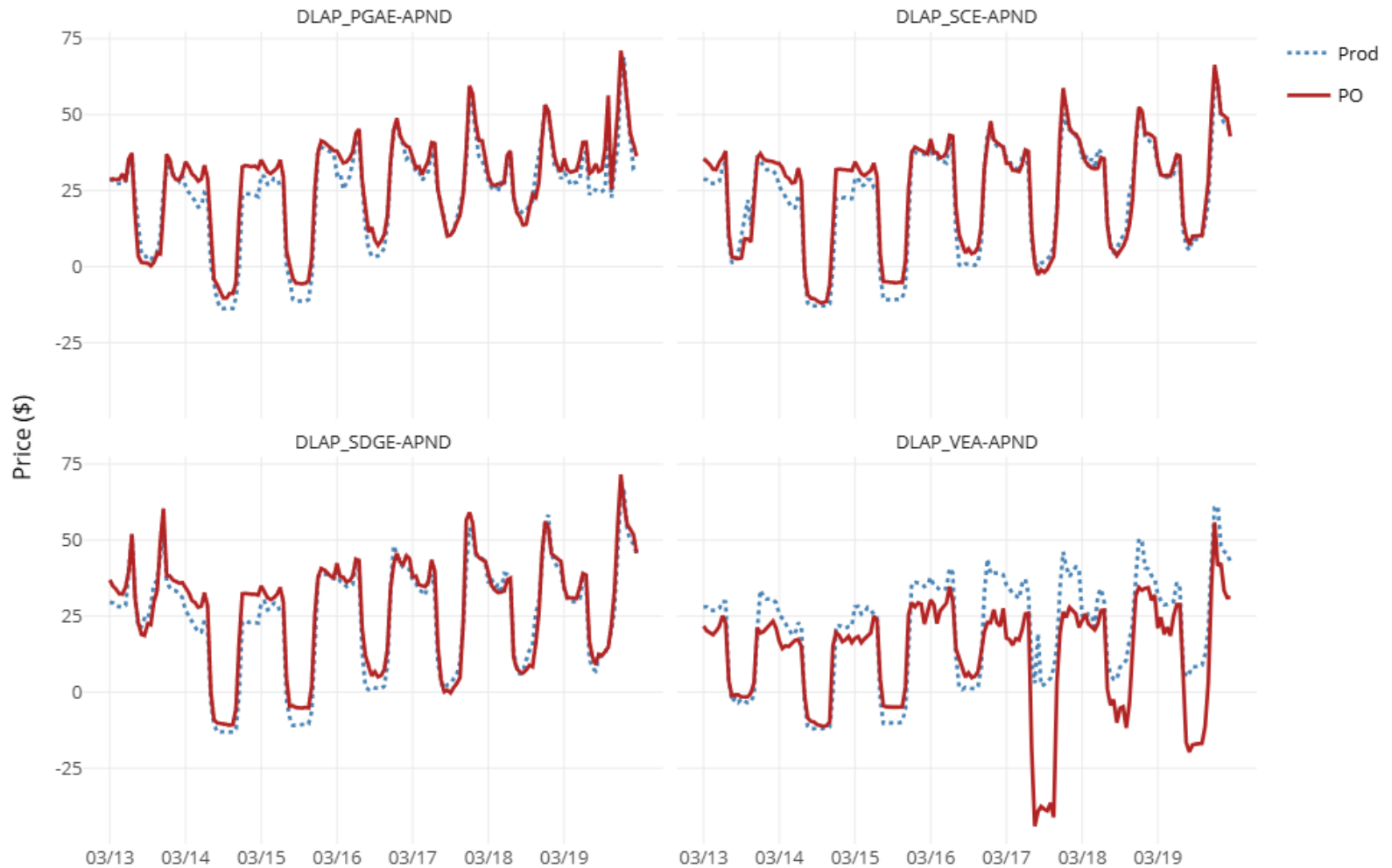

Prod to PO comparison – Battery

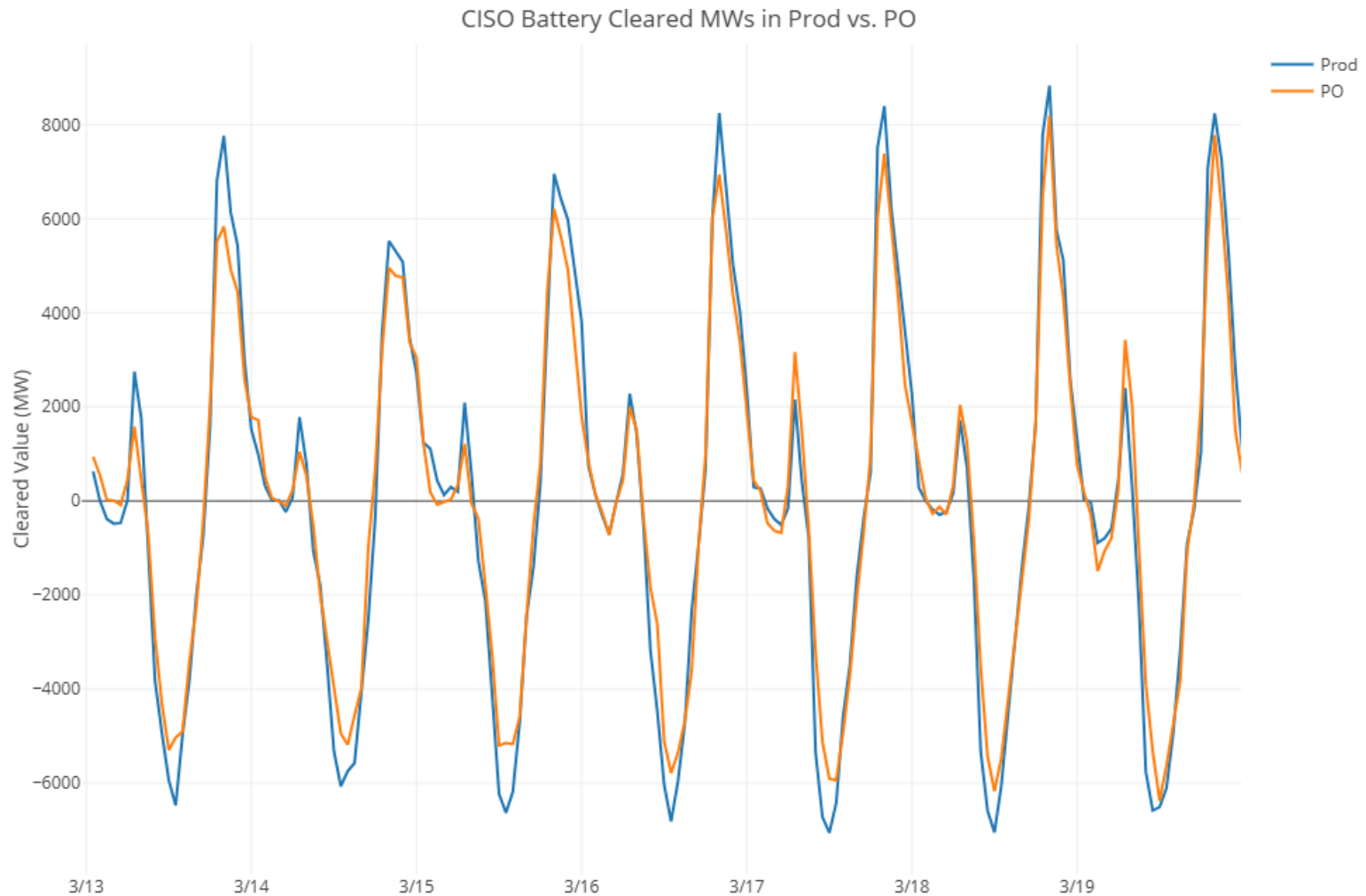

Prod to PO comparison – Exports

CISO Export Cleared MWs in Prod vs. PO

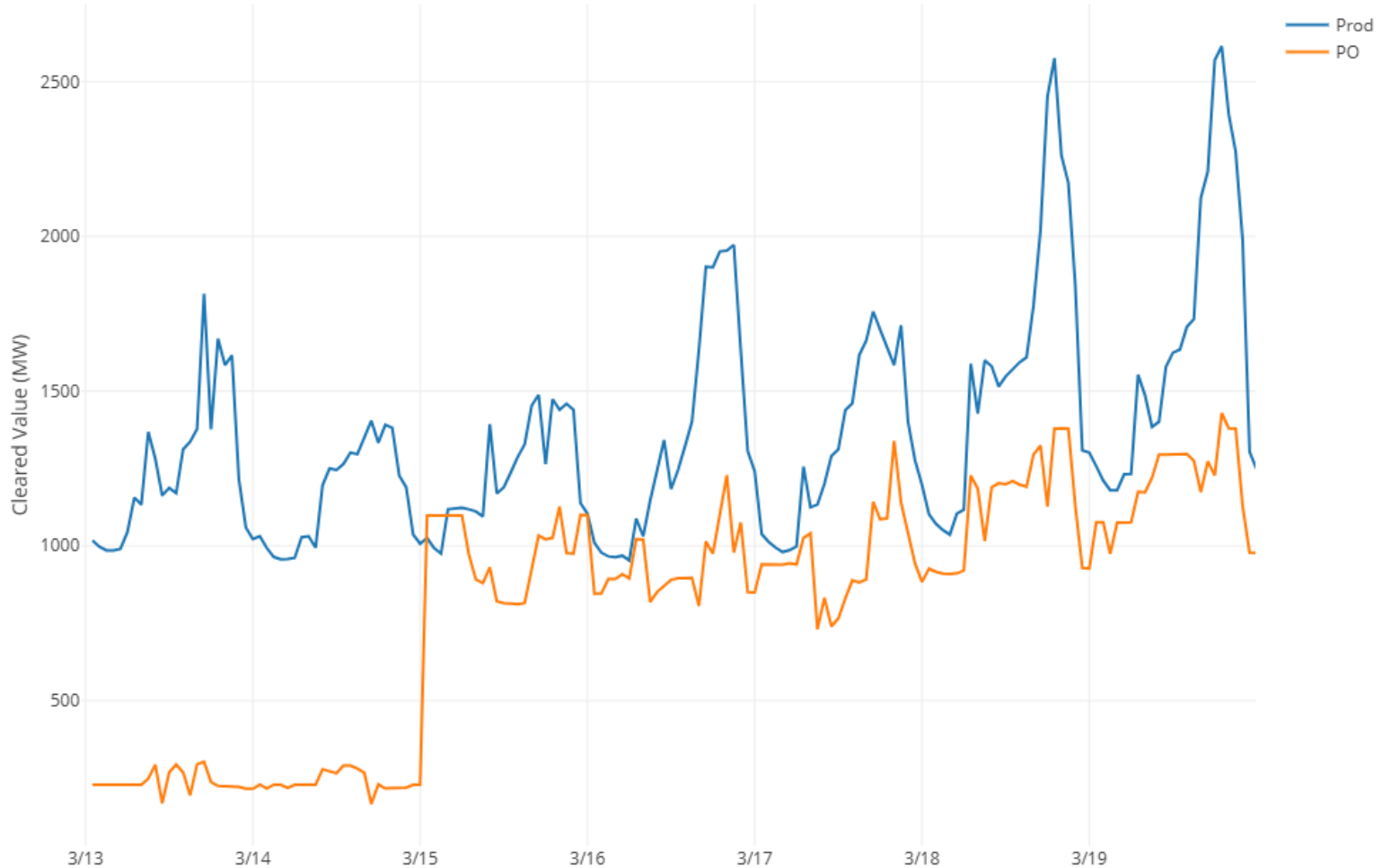

Prod to PO comparison – Imports

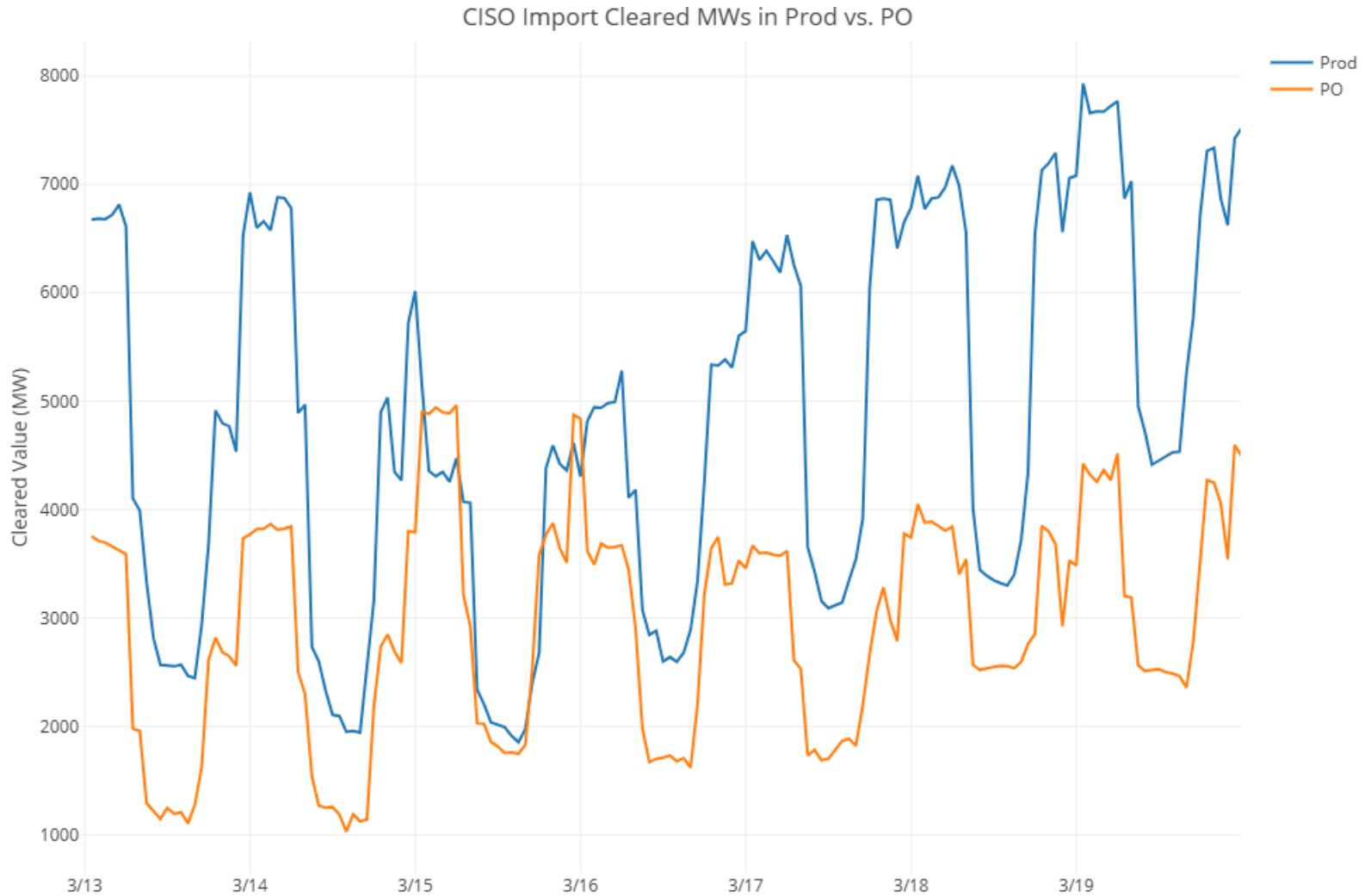

Clarification – SP/Tie price with low GHG price

Scheduling Point/Tie Combination Locational Marginal Prices (LMP)																					
Market	Opr Date	Node	Tie	LMP Type	HE01	HE02	HE03	HE04	HE05	HE06	HE07	HE08	HE09	HE10	HE11	HE12	HE13	HE14	HE15	HE16	HE17
DAM	03/02/2026	MALIN_5_N101	MALIN500	LMP	38.67810	35.76096	34.76725	32.44994	32.38826	36.09564	41.75263	26.23243	19.89072	12.71234	8.63127	4.81526	2.95470	1.08039	2.70553	7.79026	22.323
DAM	03/02/2026	MALIN_5_N101	MALIN500	Congestion	0.00000	0.00000	0.00000	0.00000	0.00000	0.00000	0.00000	0.00000	0.52504	0.36993	0.06393	0.34245	0.00000	0.00000	0.31332	1.81671	0.00000
DAM	03/02/2026	MALIN_5_N101	MALIN500	Energy	31.90481	24.18422	27.47217	28.37974	28.35086	30.42398	28.20815	12.53321	2.60510	0.26272	0.00000	-3.09290	-4.73084	-5.25403	-7.45033	-72.36143	-21.863
DAM	03/02/2026	MALIN_5_N101	MALIN500	Loss	-0.11167	-0.07981	-0.09341	-0.09082	-0.09356	-0.09736	-0.07898	-0.01629	-0.00156	-0.00024	0.00000	0.00186	0.00331	0.00420	0.00373	0.02171	0.037
DAM	03/02/2026	MALIN_5_N101	MALIN500	Greenhouse Gas	6.88496	11.65654	7.38848	4.16101	4.13095	5.76901	13.62347	13.71551	16.76214	12.07992	8.56734	7.56385	7.68223	6.33022	9.83880	78.31328	44.149
DAM	03/02/2026	MALIN_5_N101	MALIN_PGE	LMP	31.79314	24.10442	27.37877	28.28893	28.25731	30.32662	28.12916	12.51691	3.12858	0.63242	0.06393	-2.74859	-4.72753	-5.24983	-7.13328	-70.52302	-21.825
DAM	03/02/2026	MALIN_5_N101	MALIN_PGE	Congestion	0.00000	0.00000	0.00000	0.00000	0.00000	0.00000	0.00000	0.00000	0.52504	0.36993	0.06393	0.34245	0.00000	0.00000	0.31332	1.81671	0.00000
DAM	03/02/2026	MALIN_5_N101	MALIN_PGE	Energy	31.90481	24.18422	27.47217	28.37974	28.35086	30.42398	28.20815	12.53321	2.60510	0.26272	0.00000	-3.09290	-4.73084	-5.25403	-7.45033	-72.36143	-21.863
DAM	03/02/2026	MALIN_5_N101	MALIN_PGE	Loss	-0.11167	-0.07981	-0.09341	-0.09082	-0.09356	-0.09736	-0.07898	-0.01629	-0.00156	-0.00024	0.00000	0.00186	0.00331	0.00420	0.00373	0.02171	0.037
DAM	03/02/2026	MALIN_5_N101	MALIN_PGE	Greenhouse Gas	0.00000	0.00000	0.00000	0.00000	0.00000	0.00000	0.00000	0.00000	0.00000	0.00000	0.00000	0.00000	0.00000	0.00000	0.00000	0.00000	0.00000

- Case Mar. 2nd HE 16, CAISO MEC -\$72, MALIN SP-tie price \$7.79

Changes to configurable parameters went live on trade date 3/6

- The configurable parameters changes discussed on the 2/26 working group call were changed in Parallel Operations effective 3/6
 - Envelope Multiplier Constraint
 - Current value: 85%
 - New value: 60%
 - Deployed Imbalance Reserve Factor
 - Current value: 100%
 - New value: 60%

GHG changes under EDAM

- GHG prices in the WEIM today are calculated as a negative price that reduces the LMPs for BAAs outside of the CISO
 - This reflects that these non-CISO BAAs do not have a GHG obligation
- In EDAM, the GHG price will be positive and applied within the California GHG area
 - With separate MECs, it is more straightforward to add the GHG component as a positive price within the CA GHG area
- The CA GHG area is no longer equivalent to the CISO BAA.
 - VEA, which is part of the CISO BAA, is not in California and is therefore not subject to the CARB rules
 - VEA will have the same MEC as the rest of the CISO BAA but will not have the GHG price included in its LMP

GHG example 1.

\$0 GHG price case

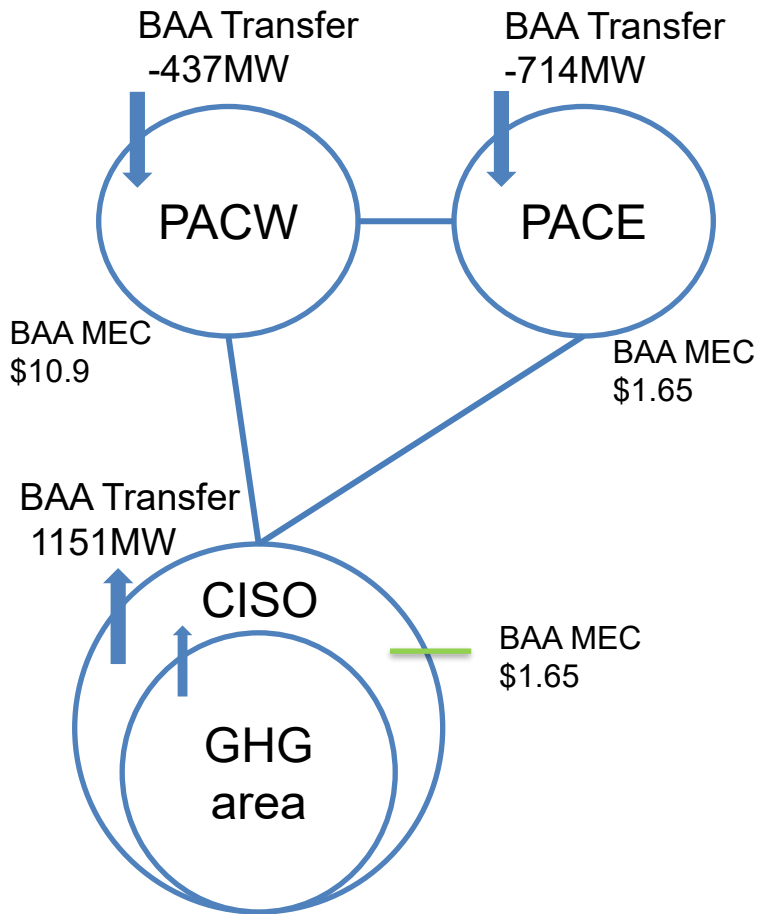

- Mar. 12th, HE13
- BAA level:
 - CISO net exporting
 - PACE, PACW net importing
- CA-GHG area is net exporting
 - GHG price @\$0

GHG example 2.

GHG price set by GHG bid in PACE area

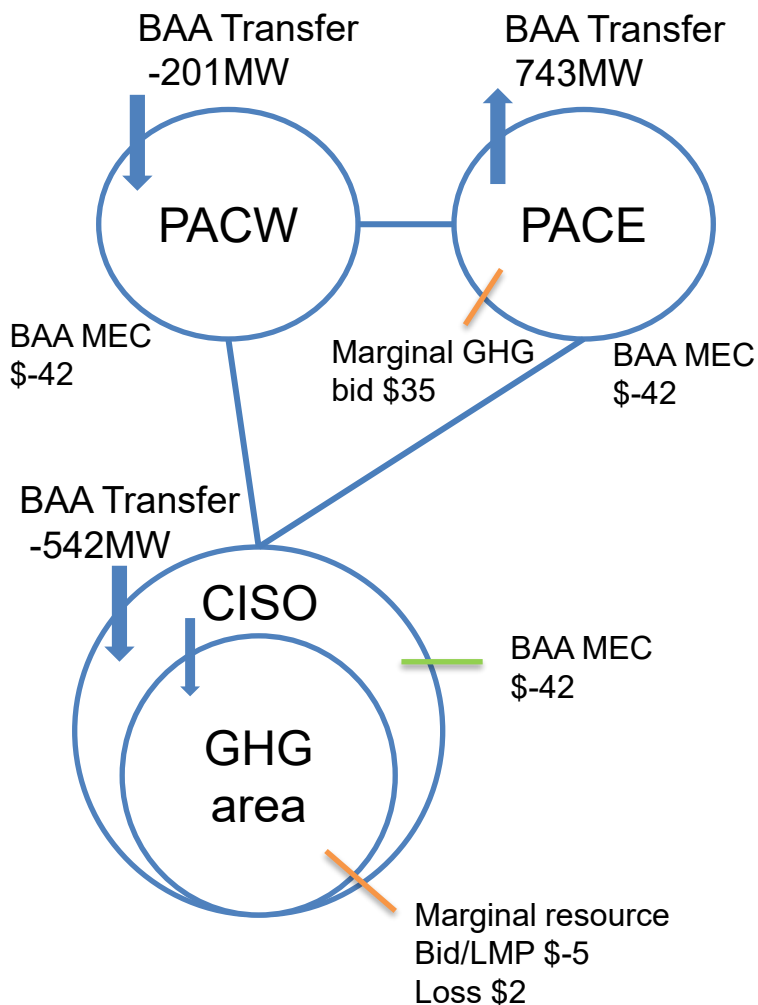

- Mar 8th, HE13
- BAA level: PACE exporting, PACW, CISO importing
 - PACE self-sched non-VER + VER supply
 - MECs @ -\$42
- GHG Received GHG bids from PACE/PACW
 - Only PACE is exporting
 - Marginal GHG bid @\$35
- CA-GHG area is net importing
 - MEC/cost outside of GHG area -\$42
 - Marginal resource within GHG area
$$LMP = MEC + Loss + GHG + Congestion$$

$$= -42 + 2 + 35 + 0 = -5 = Bid$$

GHG example 3.

No transfer case 1 on Mar. 2nd

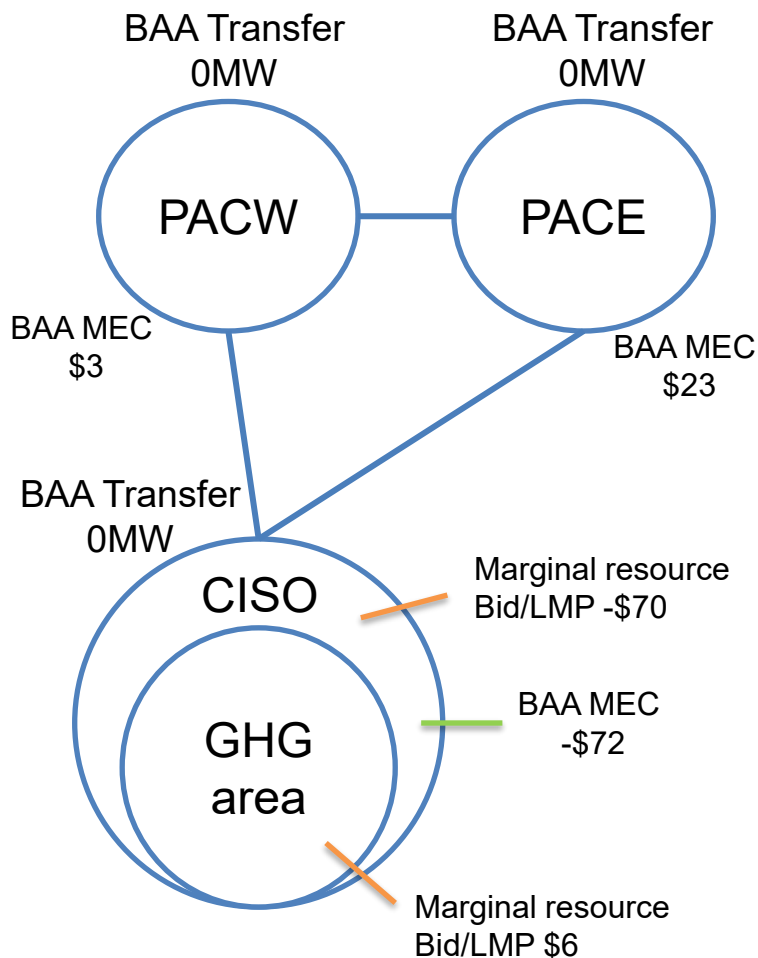

- Mar. 2nd, HE16, GHG \$78
- No transfer due to transfer limit setup
- No GHG attribution
- Within CISO BAA
 - Marginal resource outside GHG area -\$70, setting BAA MEC at -\$72
 - Marginal resource inside GHG area \$6
 - GHG price \$78 signals the price separation

GHG example 4.

No transfer case 2 on Mar. 2nd

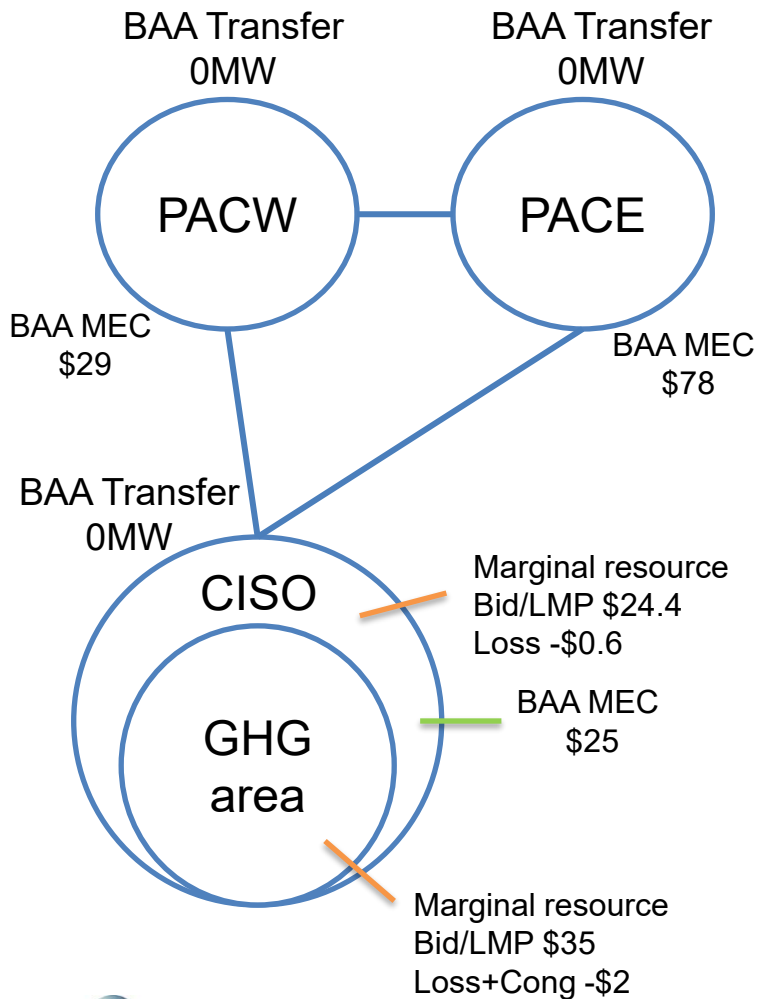

- Mar. 2nd, HE24, GHG \$12
- No transfer due to transfer limit setup
- No GHG attribution
- Within CISO BAA
 - Marginal resource outside GHG area -\$24, setting BAA MEC at -\$25
 - Marginal resource inside GHG area \$35
 - GHG price \$12 signals the price separation

Changes to configurable parameters to be enacted for trade date 3/6

- As discussed in last week's configurable parameters call, the following changes will be applied effective for DA trade date 3/6 in PO:
 - Envelope Multiplier Constraint
 - Current value: 85%
 - New value: 60%
 - Deployed Imbalance Reserve Factor
 - Current value: 100%
 - New value: 60%

Are the RCU costs allocated to virtuals? Yes

- See new EDAM Tariff language for more details

11.8.6.5.3.1 RCU Tier 1 Cost Allocation Quantity

A Scheduling Coordinator's total RCU tier 1 cost allocation quantity is the sum of the tier 1 quantities, specified as follows.

For a Scheduling Coordinator with net Virtual Supply Awards in a Trading Hour, the RCU tier 1 cost allocation quantity associated with its Virtual Supply is the higher of: (a) zero; or (b) the Scheduling Coordinator's net Virtual Awards, if the Balancing Authority Area in which that Scheduling Coordinator is located has net Virtual Supply.

For a Scheduling Coordinator with under-scheduled Load in a Trading Hour, the RCU tier 1 cost allocation quantity associated with its under-scheduled Load is the net negative metered Demand, excluding net negative Demand associated with balanced ETC/TOR rights and negative deviation for Participating Load resulting from a market dispatch.

SIBR Patch 27

Description/Identifier	
F25 - EDAM Rules 12.3.4 for RCU and RCD on MSG resource RTM support with different states BRQ-11000	MSG RTM rules when RCU/RCD potentially in different state than the IFM. Energy Bid generation or extension based on award.
F25 - EDAM Retrieve service for RSE Capacity report	New retrieve API for RSE Capacity report (EDAM role)
F25_EDAM_Retrieve API, should return Rule# with rule messages for both Valid and Invalid bids	Fix for retrieve services to return the rule messages for submissions that are either Valid, and more importantly Invalid or Rejected.
F25: EDAM : Fix Rule 39402 and relax 39404	Relax SC check for Released Capacity submit, must be valid SC and the CRN is associated to Transfer Location, also same for the TCSC List, having the EESC as the submit associated with the CRN responsible SC.
F25_EDAM_TSR Identifier >25 should allow in API	Allow the alpha-numeric identifier to be 2 characters in an API submission.
F25_EDAM_submitting TCSC list fires 39301, it should not	Same as for 39402 in HPCQC 92399.
F25_EDAM_LPT Export Resource Non EDAM BAA firing 23220 rule,it should not	Allow Export resource (Non-EDAM) to have an LPT Self-Schedule.
F25_EDAM_CRN Validation Rules INA 39602	EDAM Entity SC update to the EDAM CRN Entitlement validation to be from the EESC.

SIBR Patch 26 Promoted to MAPSTAGE & STAGE

Description/Identifier	
EDAM; SIBR - RetrieveBARequirementData_SIBRv1_RW role and RO role- for SC that does not belongs to the certificate - improper error message	Error message fixed: SubmitReleasedCapacityBid_SIBRv1_AP -- with invalid SCID:User Is Not authorized to submit released capacity for the specified SC
F25_EDAM_QRB2_Registered TSR type 2_rule 43801 not fired-BRQ-11144f	TSR Matched status properly set on bid when Matching TSR found.
F25 - EDAM Enhancement Transient UI filter logic	Typing in a portion of the contract will filter in the UI display.
F25_EDAM_Registered Intertie with TCL does not fire a rule 23026	Will not allow a non TSR to submit TCL.
F25_EDAM_EDAM_BARequirement Copy issue	A placeholder set of rows will be created when copying an EDAM BA Requirement with empty records.
F25 - EDAM SBR Entitlement for EDAM contracts set to 0 when ETCC comes in.	The procedure has been corrected, Master File EDAM contract with Entitlement is written to the database correctly and the incoming ETCC payload no longer zero's the CRN Entitlement in the table for the EDAM CRNs.
F25 - EDAM SIBR UI RSE Capacity enhancement	Transient TSR available and TCL as a product

SIBR Patch 26 Promoted to MAPSTAGE & STAGE

<p>F25: EDAM SubmitTotalTaggedImport should be accepted for the same TD</p>	<p>Total Tagged Import was not being allowed to submit after 10, now it can be received for the active day after 10am.</p>
<p>F25 - EDAM Rule 43023 for Transient TSR check and add 53046 post close BRQ-11144</p>	<p>TSR Matched status check at Post Close, if Matched Status is N then the bid will become invalid. (both TSR pairs must be market accepted.)</p>
<p>F25_EDAM_EDAMBARRequirement_AS Region submit vs Retrieve is not same</p>	<p>Corrected the MarketRegion name in the BARRequirement payload generated through the retrieveBARRequirementData_v1SIBR service, now the return data matches the submit data.</p>
<p>F25_EDAM_Rule 41333 fired on Gen bid, should fire on MSG bid</p>	<p>Now will fire on MSG resource correctly and without duplicate price curve data on bid.</p>
<p>F25 - EDAM INA rule 31671 and modify 41674</p>	<p>This allows a GHG Bid price to come in even above the Max Price from ECIC for the resource. Rule 41674 will cap the price for the resource, if there is no price from ECIC it will be a \$0 price.</p>
<p>F25 - EDAM need for rule 43121 from 12.3.3</p>	<p>A non TSR Import with RCU and no Energy curve, will generate an Energy curve to support the RCU Award.</p>
<p>F25 - EDAM duplicate price segment data in processing rules supporting awards</p>	<p>(this was the 41333 rule fix)</p>
<p>F25: EDAM : Rule 33802 did not fire on non-integer or negative Capacity Limit</p>	<p>The TCL submitted for TSR must be greater than 0 and be a integer.</p>
<p>F25 - EDAM INA rule 39304, covered by 30025 BRQ-11140</p>	<p>The SC provided in the TCSC List must be a registered SC, it does not have to be the SC associated to the CRN. The CRN association belongs with the Transfer Location, and the CRN association is with the EESC.</p>
<p>F25 - EDAM INA rule 31936 Add 41955 for RCU processing BRQ-11210</p>	<p>41955 will check the RCU capacity, and if it is submitted greater than the certified capacity or the UEL it will cap the RCU capacity to the lower of. 31936 was inactivated but we also found that rule 31911 also needs to be inactivated to allow 41955 to process. That is coming in patch 27.</p>

EDAM Participant Training Courses

SIBR Training Courses

March 10: **SIBR Fundamentals**

- This training will explore the core interface, walk through submitting and validating Energy and AS bids, and review the resulting outputs.
- Target Audience: SIBR users
- Registration Link: <https://caiso.regfox.com/scheduling-infrastructure-and-business-rules-sibr-fundamentals>

March 19: **SIBR Advanced Bid Submission & Validation**

- This training provides walk through complex bid-submission scenarios—including TSR Types 1–4, transient TSRs, contract reference numbers, and transfer capacity limits—and show how to resolve common errors step-by-step
- Target Audience: SIBR users
- Registration Link: <https://caiso.regfox.com/training-scheduling-infrastructure-and-business-rules-sibr-advanced-bid-submission--validation->

SIBR Training Materials

Visit the [Western Energy Markets](#) page on the ISO Training Center:

- EDAM Scheduling Infrastructure Business Rules (SIBR) Training presentation & video
- [Transient Transfer System Resource Bid Submission in Scheduling Infrastructure Business Rules \(SIBR\)](#)

Training Courses: Process for Submitting Bids / Schedules in SIBR

To find basic information on bids and base schedules, view the following resources:

- Computer-based training courses:
 - [Economic Bids and Self Schedules](#)
 - [EDAM Bidding Basic Concepts](#)
- Instructor led training presentations and recordings:
 - [EDAM Scheduling Infrastructure Business Rules \(SIBR\) Training presentation](#)
 - [EDAM Scheduling Infrastructure Business Rules \(SIBR\) Training video](#)
 - [Transient Transfer System Resource Bid Submission in Scheduling Infrastructure Business Rules \(SIBR\) Presentation](#)
 - [EDAM Bidding Intermediate – presentation](#)
 - [EDAM Scheduling Coordinator Training Day 2, September 11th, 2025 – recording](#)
- CAISO public [SIBR Bidding](#) webpage
 - [SIBR User Guide](#)

Training Courses: Intertie Scheduling and Modeling

To find information on intertie scheduling and modeling, view the following resources:

- Instructor led training presentations and recordings:
 - [Presentation - EDAM Intertie Scheduling Readiness Training](#)
 - [Video - EDAM Intertie Scheduling Readiness Training](#)
 - [Presentation - Extended Day-Ahead Market \(EDAM\) Implementation - Intertie Scheduling Readiness Workshop - Jan 29, 2026](#)
 - [Video - Extended Day-Ahead Market EDAM Implementation - Intertie Scheduling Readiness and Q&A Session Workshop - Jan 30, 2026](#)
- Resources
 - [EDAM FAQ Guide](#), Intertie Scheduling and Modeling section

Helpful Links

- [DAME Scenarios](#)
- [EDAM Scenarios](#)
- [Settlements Phase 1 Charge Codes](#)
- [Settlements Phase 2 Charge Codes](#)
- [Settlements DAME/EDAM Draft Config Outfile File](#)
- [Settlements BPM Walkthrough](#)
- [Access Charge Submission Template](#)
- [Access Charge Submission Procedure](#)
- [SIBR Rules](#)
- [Settlements Calendar](#)
- [Parallel Operations Plan](#)