



Integration of Renewable Resources:

Technical Appendices for California ISO Renewable Integration Studies

Version 1

FIRST DRAFT FOR EXTERNAL REVIEW
October 11, 2010

This first draft is being released for review purposes and will undergo further revisions and edits following stakeholder comments on the 20% RPS Study and this draft document due October 20. Some notation has not yet been standardized as noted in the text. Some sections are still incomplete. The ISO may release a second draft version prior to a final version that supports both the 20% RPS study and the forthcoming 33% RPS studies.

Table of Contents

INTRODUCTION	1
OVERVIEW OF METHODOLOGIES AND APPENDICES	2
CONTRIBUTORS	3
 SECTION A	 4
A-1 DAY-AHEAD MARKET (DAM) SCHEDULING PROCESSES AND TIMELINES.....	4
A-2 HOUR-AHEAD AND REAL-TIME MARKET (RTM) SCHEDULING PROCESSES AND TIMELINES	7
 SECTION B	 16
B-1 SELECTION OF TARGET YEAR FOR ANALYSIS	16
B-2 LOAD FORECAST AND PROFILING FOR TARGET YEAR.....	17
B-3 DETERMINATION OF RENEWABLE RESOURCE PORTFOLIOS AND “NET SHORT” RENEWABLE ENERGY	17
B-4 WIND GENERATION PROFILE FOR TARGET YEAR.....	18
WIND GENERATION PROFILES FOR THE 20% RPS STUDY	18
WIND GENERATION PROFILES FOR THE 33% RPS STUDIES.....	22
B-5 SOLAR GENERATION PROFILE FOR TARGET YEAR	25
B-6 ANALYSIS OF LOAD FORECAST ERROR	31
B-7 ANALYSIS OF WIND FORECAST ERROR	35
B-8 ANALYSIS OF SOLAR GENERATION FORECAST ERROR.....	37
UPPER AND LOWER LIMITS FOR THE SOLAR GENERATION FORECAST ERROR.....	37
STANDARD DEVIATION OF THE FORECAST ERROR EVALUATED USING CI	38
<i>Truncated Normal Distribution</i>	<i>38</i>
<i>Asymmetries of the Forecast Error.....</i>	<i>40</i>
AUTOCORRELATION AND CROSS-CORRELATION OF THE FORECAST ERROR	40
EVALUATION OF FORECAST ERROR BASED ON CI.....	41
CONSIDERATION OF TECHNOLOGICAL AND GEOGRAPHICAL DIVERSITY.....	41
B-9 IMPROVEMENTS IN FORECAST ERRORS	42
 SECTION C	 43
C-1 METHODOLOGY FOR STATISTICAL ANALYSIS OF OPERATIONAL REQUIREMENTS....	43
DETERMINATION OF IN-STATE VS. OUT-OF-STATE RESOURCES	44
ACTUAL LOAD AND WIND/SOLAR GENERATION IN THE TARGET YEAR	44
HOUR-AHEAD SCHEDULE FOR LOAD AND WIND/SOLAR GENERATION	45
<i>Hour Ahead Load Schedule Model.....</i>	<i>45</i>
<i>Hour-Ahead Wind Generation Schedule Model</i>	<i>47</i>
<i>Hour-ahead Solar Generation Schedule Model.....</i>	<i>49</i>
REAL-TIME FIVE-MINUTE SCHEDULE FOR LOAD AND WIND/SOLAR GENERATION	50
<i>Real Time Load Forecast.....</i>	<i>50</i>
<i>Real-Time Wind Generation Forecast Model.....</i>	<i>52</i>
<i>Real-time Solar Generation Forecast Model.....</i>	<i>52</i>
DEFINITION AND MEASUREMENT OF REGULATION AND LOAD-FOLLOWING	53
ASSESSMENT OF RAMPING REQUIREMENTS	55

CONCURRENT STATISTICAL ANALYSIS OF THE REGULATION AND LOAD FOLLOWING REQUIREMENTS56
ITERATIONS OF THE MONTE CARLO SIMULATION.....58
SENSITIVITY STUDIES58
PRESENTATION OF SIMULATION RESULTS58
ANALYTICAL FLOW CHARTS FOR THE STATISTICAL MODELING60

SECTION D63

D-1 MATHEMATICAL STRUCTURE OF THE PRODUCTION SIMULATION MODELS64

OBJECTIVE FUNCTION64
REPRESENTATION OF COST COMPONENTS FOR ENERGY AND ANCILLARY SERVICES67
ENERGY BALANCE CONSTRAINT68
ANCILLARY SERVICES CONSTRAINTS.....69
RAMP-SHARING CONSTRAINTS71
PENALTY COSTS FOR CONSTRAINT VIOLATIONS.....73
OTHER GENERATION UNIT INTER-TEMPORAL CONSTRAINTS74
GENERAL ASSUMPTIONS ABOUT DISPATCHABILITY OF GENERATION TYPES76
MODELING OF COMBINED CYCLE GENERATION.....76
MODELING OF HYDRO AND PUMPED STORAGE.....77
MINIMUM GENERATION CONSTRAINTS77
NETWORK CONSTRAINTS78

D-2 DETERMINATION OF LOAD-FOLLOWING AND REGULATION CAPACITY REQUIREMENTS79

D-3 DETERMINATION OF PLANNING RESERVE MARGIN AND NET QUALIFYING CAPACITY FOR GENERATION RESOURCES82

D-4 STRUCTURE OF A STOCHASTIC, SEQUENTIAL PRODUCTION SIMULATION FOR SELECTED DAYS82

SELECTION OF DAYS TO MODEL.....84
DAY-AHEAD AND HOUR-AHEAD FORECASTS84

D-5 STOCHASTIC MODELING OF DAY-AHEAD AND HOUR-AHEAD WIND AND LOAD FORECASTS FOR PRODUCTION SIMULATIONS86

D-6 CALCULATION OF RENEWABLE INTEGRATION COSTS92

SECTION E93

E-1 OVERVIEW OF EMPIRICAL ANALYSIS OF ISO DATA93

E-2 ANALYSIS OF HISTORICAL ISO DATA ON OPERATIONAL CAPABILITY.....94

UPWARD LOAD-FOLLOWING CAPABILITY94
DOWNWARD LOAD-FOLLOWING CAPABILITY95
REGULATION 5-MINUTE RAMP CAPABILITY OF BID-IN CAPACITY.....95

E-3 COMPARISON OF HISTORICAL DATA AND SIMULATION RESULTS.....96

REFERENCES97

CONTRIBUTORS.....99

Tables

Table 1: New Solar Plants Modeled in the 20% 2012 Study.....	26
Table 2: Monthly Cloud Speeds	26
Table 3: Plant Area by Technology	27
Table 4: Summary of 2006 hour-ahead load forecast error (Actual Load – Forecast Load)	33
Table 5: Summary of five-minute load forecast error, Spring 2006.....	34
Table 6: Summary of two hour-ahead wind forecast error in 2006	35
Table 7: Summary of forecast error statistics in current, improved and zero forecast error cases.....	42
Table 8: Standard deviations of solar forecast errors based on clearness index levels ...	50
Table 9: Key Dimensions of Load-following Capacity Constraints	79
Table 10: Key Dimensions of Regulation Capacity Constraints	81
Table 11: Definitions and characteristics of units based on start-times.....	83
Table 12: Wind forecast error statistics, comparison of historical vs. modeled results.....	87
Table 13: Load forecast error statistics, comparison of historical vs. modeled results.....	87
Table 14: Day-ahead load forecast statistical characteristics, PG&E region.....	88
Table 15: Hour-ahead load forecast statistical characteristics, PG&E region	88
Table 16: Day-ahead load forecast statistical characteristics, SDG&E region	89
Table 17: Hour-ahead load forecast statistical characteristics, SDG&E region.....	89
Table 18: Day-ahead load forecast statistical characteristics, SCE region	89
Table 19: Hour-ahead load forecast statistical characteristics, SCE region	90
Table 20: Day-Ahead and Hour-Ahead Wind Generation forecast characteristics.....	90
Table 21: Cross-correlation between Day-Ahead and Hour-Ahead load forecast errors..	90
Table 22: Cross-correlation between Day-Ahead and Hour-Ahead wind generation forecast errors.....	90
Table 23: Cross-correlation between Day-Ahead load and wind generation forecast errors	91
Table 24: Cross-correlation between Hour-Ahead load and wind generation forecast errors	91

Figures

Figure 1: ISO Balancing Area Scheduling Process	8
Figure 2: ISO Hour-Ahead Timeline	9
Figure 3: Schematic of the Production, Delivery and Usage Time Line for PIRP Next Operating Hour Forecast.....	10

Figure 4: ISO Real Time Dispatch Timeline 12

Figure 5: RTED Dispatch Ramping Projection..... 12

Figure 6: Expected Wind Energy Production with Linear Ramps..... 19

Figure 7: Sample Wind Production with Hourly Average and Moving Average 20

Figure 8: Possible Average Wind Generation Pattern 20

Figure 9: Correlation of Short-Term Variations of Wind Parks in Solano and Tehachapi, May 2006 21

Figure 10: Correlation of Short-Term Variations of Two Wind Parks in Tehachapi Resource Area, May 2006 21

Figure 11: Response to Step Increase in Irradiance by Solar Thermal Technology..... 27

Figure 12: SMUD 1 Minute Irradiance Data for September 2009 28

Figure 13: 1 Minute Irradiance for September 13, 2009 28

Figure 14: Hourly Production Data Output from SAM Model 30

Figure 15: Hourly Production Data Output from SAM Model After Spline Fit 31

Figure 16: Hourly Production Data Output from SAM Model After Variability Is Added.... 31

Figure 17: Unbiased Truncated Normal Distribution 32

Figure 18: Hour-Ahead Load Forecasting Error, Spring 2006..... 34

Figure 19: Comparison of five-minute load forecast error and theoretical error distribution, mid-May to mid-April, 2006 34

Figure 20: Two-hour-ahead wind forecasting error, Spring 2006..... 36

Figure 21: Distribution of the standard deviation of solar forecast error depending on the clearness index..... 38

Figure 22: Distribution of solar forecast error on (a) a very cloudy day and (b) a very sunny day 40

Figure 23: CAISO Simulated Hour Ahead Load Schedule (Red Line) 46

Figure 24: Probability Density Function (PDF) of the Load Forecast Function (Red Line) 47

Figure 25: CAISO Simulated Real Time Load Forecast (Red Line) 51

Figure 26: Depiction of the Regulation requirement, shown as the red shaded area 54

Figure 27: Depiction of hourly load-following requirement, shown as the blue area..... 55

Figure 28: Concept for the "Swinging Door" Algorithm 56

Figure 29: "Swinging Window" Algorithm – Obtaining Regulation, Ramps, and Their Duration 56

Figure 30: Concurrent consideration of the capacity, ramping and duration requirements57

Figure 31: Analytical Flow Chart for Calculating Load-following Capacity Requirements 61

Figure 32: Analytical Flow Chart for Calculating Regulation Capacity Requirement 62

Figure 33: Generation Energy Cost Curve 68

Figure 34: Cooling, Startup, and Down Time 74

Figure 35: Startup Time Function 75

Figure 36: Flowchart of the Stochastic, Sequential Production Simulation Methodology . 85

Figure 37: Measurement of 5-minute load following up capability 94

Acronyms

AGC	automatic generation control
BAA	Balancing Authority Area
BPM	Business Practice Manual
CEC	California Energy Commission
CPUC	California Public Utilities Commission
CREZ	Competitive Renewable Energy Zones
DOP	Dispatch Operating Point
EMS	Energy Management System
FERC	Federal Energy Regulatory Commission
FNM	Full Network Model
LMP	Locational Marginal Prices
LSE	load-serving entity
MW	megawatt
MWh	megawatt-hour of energy
NERC	North American Electric Reliability Council
PG&E	Pacific Gas & Electric
PIRP	Participating Intermittent Resource Program
QF	Qualifying Facility
RA	resource adequacy
RPS	Renewable Portfolio Standard
SCE	Southern California Edison
SDG&E	San Diego Gas & Electric
TND	Truncated Normal Distribution
WECC	Western Electricity Coordinating Council

Notation

[TO BE COMPLETED]

Introduction

The California ISO – along with many other entities involved in power system operations, markets and regulation – is developing analytical methods to forecast the operational and market requirements and impacts associated with the integration of variable energy resources – primarily wind and solar – into the California and western power system. These methods have been applied by the ISO in several studies that simulate future system conditions, notably reports on renewable integration at 20% RPS issued in November 2007¹ and August 2010,² as well as interim results on studies of 33% RPS.³ The methods are intended to support future studies as those become defined. Such studies could become an integral component of system planning and resource development and procurement under the State’s renewable policy goals. These technical appendices are intended to accompany the ISO’s studies and to be updated regularly as methodology changes over time.

The appendices currently address three types of analysis conducted over 2007-2010:

- Statistical modeling of operational requirements on various time-frames and time-steps;
- Production simulation of unit commitment and dispatch that can incorporate forecast uncertainty;
- Empirical analysis of historical generator capabilities and inherent characteristics of the ISO dispatch solutions and market procurement of ancillary services.

In addition, the studies themselves will include aspects of methodology that are not repeated in these appendices. Hence, readers should review both the studies and appendices for the most complete statement of methodology.

These appendices do not review and compare the ISO methodology with that used in other recent operational studies of renewable integration in California.⁴

The actual ISO markets and system operations are more complicated than can typically be captured in the simulations (although the ISO will on occasion conduct detailed simulations of particular operational conditions using the full network model and market data). Where possible, the appendices refer to the actual ISO technical bulletins and business practice manuals and other types of information that offer more insight into actual practice. The ISO will use the combination of simulations, empirical data, operational tools and operational experience to determine how to adjust its procurement of ancillary services, to conduct unit commitment, and possibly to change market rules to improve operational

¹ California ISO, *Integration of Renewable Resources – Transmission and Operating Issues and Recommendations for Integrating Renewable Resources on the ISO-Controlled Grid* (Nov. 2007), available at <http://www.caiso.com/1ca5/1ca5a7a026270.pdf>.

² California ISO, *Integration of Renewable Resources – Operational Requirements and Generation Fleet Capability at 20% RPS* (August 31, 2010), available at <http://www.caiso.com/2804/2804d036401f0.pdf>.

³ See updates at http://www.cpuc.ca.gov/PUC/energy/Renewables/100824_workshop.htm.

⁴ E.g., KEMA, *Research Evaluation of Wind Generation, Solar Generation, and Storage Impact on the California Grid* (June 2010), <http://www.energy.ca.gov/2010publications/CEC-500-2010-010/CEC-500-2010-010.PDF>.

flexibility.⁵ Importantly, the ISO will need to conduct such detailed analysis using confidential market data, alongside the large-scale simulations using public data that are intended to capture longer-term trends in system operations and markets.

Overview of methodologies and appendices

The starting point for the ISO's analyses are the day-ahead and real-time market and scheduling processes, including the timelines for unit commitment and dispatch decisions. Section A provides an overview of those processes along with their correspondence to the simulations described in subsequent sections.

To date, the ISO's operational studies have evaluated a subset of key *operational requirements* that include (1) operational ramp rates at different time scales, (2) regulation capacity and ramp rate, and (3) load-following up and down capacity and ramp rates. These requirements are estimated using a statistical simulation methodology that evaluates impact of load and wind and solar production forecast error and variability on these requirements. The key inputs into this statistical model are described in Section B, and the full model is presented in Section C.

Operational capability refers to the ability of the ISO's existing and planned generation and non-generation resources to address the incremental operational requirements as a result of variable energy resources. To date, operational capabilities have been evaluated on two separate tracks:

- First, the ISO has used both deterministic and stochastic production simulations to estimate whether the generation fleet possesses the capability to meet load in both hourly and sub-hourly time frames and supply the required ancillary services. These simulations are described in Section D.
- Second, the ISO is reviewing data on the certified operational characteristics of the existing generation and pumped storage resources to gain insight into capacity with different ranges of start-up times, operational ramp rates and regulation capacity and ramp rates. The ISO also has analyzed historical operational and market data to evaluate what additional operational flexibility might be available in current operations to accommodate renewable integration (i.e., without requiring changes to market operations or procurement of additional reserves). These analyses are described in Section E.

As described in this document, the simulations begin from the development of common data as inputs. The statistical model then provides the estimates of operational requirements, including additional load-following and regulation capacity and ramp rates. The additional operational capacity requirements are then included in the production simulation models, under rules discussed in Appendix D. The statistical modeling has thus been characterized as "Step 1" and the production simulation as "Step 2" to reflect the sequence in which the analysis is conducted. Future analysis may conjoin the two steps into a single stochastic unit commitment model.

⁵ See, e.g., the ISO's renewable integration market and product review, with materials available here: <http://www.caiso.com/27be/27beb7931d800.html>.

This version of the appendices does not include extensions of the methodology into subsequent phases that may have been discussed in stakeholder forums. These include, e.g., additional modeling of storage and demand response capabilities, and dispatch of variable energy resources under certain system conditions. As the methodologies for such extensions are developed, they may be added to these appendices.

Contributors

To develop the methodologies reviewed in this appendix, the ISO has worked with a number of firms and research organizations, members of a renewable integration working group, and other stakeholders that have offered comments. The ISO would like to note the contributions of Pacific Northwest National Laboratories (PNL), which developed the model of solar forecasting and the statistical methodology discussed in Appendices B and C, Truepower, which developed the wind forecast model for the 20% RPS Study discussed in Appendix B-4, Nexant, which developed the solar production model discussed in Appendix B-5 and wind production profiles for the 33% RPS study in Appendix B-4, and members of the 33% RPS working group, PLEXOS and GE Consulting for assisting in the development and implementation of the production simulation models discussed in Appendix D. GE Consulting also provided reviews of other aspects of the methodology for the 20% RPS study. Individual contributors are listed at the end of the appendices.

The ISO notes that the participants identified on the last page of this document as contributing to the development of model methodology and implementation of various components of the modeling have not necessarily endorsed all aspects of the methodology, input assumptions, or results, nor have their organizations. The ISO is appreciative of the efforts of these participants in advancing the understanding of renewable integration modeling.

SECTION A

The operational studies are focused on how wind and solar resources are integrated into ISO day-ahead, hour-ahead, and real-time market and system operational procedures. This section very briefly reviews these processes and timelines as referenced in the remaining appendices in this document. Both in this section and in subsequent sections, the parallels between the simulations and the actual market processes will be noted and their implications explained. Readers familiar with these ISO procedures can skip this section.

The ISO's integrated market, scheduling and system operational procedures are ordered as follows:

- Pre-day-ahead commitment decisions (mainly for long-start units);
- Day-Ahead Market (DAM), including the Integrated Forward Market (IFM) and the Residual Unit Commitment (RUC), both of which clear on an hourly basis;
- The Hour-Ahead Scheduling Procedure (HASP) that schedules supply and demand at the inter-ties on an hour-ahead basis and is also the time-frame for submission of hour-ahead forecast wind and solar schedules under the Participating Intermittent Resources Program (PIRP); and
- The Real-Time Market, a set of concurrent unit commitment and dispatch procedures that result in the 5-minute real-time dispatch of internal resources and dynamically scheduled imports.

Each of the DAM, HASP and RTM processes utilize a full network model that incorporates all significant transmission and resource operating constraints. More information on the markets and system operations can be found in the ISO's business practice manuals (BPMs), tariff, and other technical documents; this section focuses on a few key features applicable to the renewable integration studies.¹

A-1 Day-Ahead Market (DAM) Scheduling Processes and Timelines

Because generation resources have different start-up times (ranging from more than 24 hours for large steam units to under 10 minutes for gas turbines), system operators must begin the process of scheduling generation before the operating day. The DAM, which includes both the IFM and RUC, is the primary process for scheduling supply (including unit commitment of medium and long start resource) and

¹ On market and system operations, see in particular the BPM for market instruments and the BPM for market operations. These are available at <http://www.caiso.com/17ba/17baa8bc1ce20.html>. More detail on the ISO's market and system operations and renewable integration can be found in the ISO's comments to the Federal Energy Regulatory Commission (FERC) in its recent notice of inquiry on variable energy resources, available here: <http://www.caiso.com/2777/2777ac8636f20.pdf>. In addition, the ISO will be undertaking a detailed review of market design changes needed to facilitate renewable integration, with documents and schedules provided here: <http://www.caiso.com/27be/27beb7931d800.html>.

demand (or load) the day prior to the operating day. The IFM – an auction for energy and ancillary services to serve next day demand – is executed daily based on bid-in supply and demand (which includes internal load and exports), to provide the hourly schedules for supply and demand for the next operating day. Through the IFM, the ISO also procures 100 percent of its market-based ancillary services – Regulation Up, Regulation Down, Spinning Reserve and Non-spinning Reserve – for the next day based on ancillary services requirements and ancillary services supply bids or submissions for self-provision of ancillary services. The ISO then conducts the Residual Unit Commitment (RUC), which adjusts capacity commitments based on the ISO’s forecast of CAISO demand and submitted RUC capacity bids for supply. The ISO forecast of CAISO demand can include adjustment for potential forecast error and expected level of renewable generation not already scheduled as a result of IFM. Further details are provided below. The RUC schedules and prices conclude the DAM process.

The DAM timelines are as follows. The DAM process begins seven days prior to the operating day when the bid submission process begins and continues through the day prior to the operating day until the Day-Ahead Schedule and Ancillary Services awards are issued. Two days before the DAM is conducted, the system operators conduct manual procedures for the commitment of extra-long start resources that require more than eighteen hours to start and evaluate the state of the grid for the purposes of preparing the system for the DAM. The deadline for submitting bids to the DAM is 10:00 AM. Participants can submit price and quantity bids (\$/MWh) from generation or eligible non-generation resources (e.g., demand response and storage) that can potentially supply spot energy or market-based ancillary services. In addition, participants can submit bids to buy energy (\$/MWh) to serve the next day’s load or price-taker self-schedules (MWh) – requests to inject and withdraw power independent of the market price –at the same time.² Resources are committed through the IFM and RUC to meet either bid-in load or block hourly load schedules in a manner to avoid any potential ramp limitations from one hour to the next.

A key feature of the DAM is that resources that have Resource Adequacy contracts and are not use-limited are typically required to submit either bids or self-schedules into the IFM and the RUC;³ units with Resource Adequacy contracts that are use-limited, such as hydro, generally have to submit schedules based on their expected production.⁴

Currently, there is no requirement, and only weak financial incentives, for wind and solar resources to schedule or offer their power into the IFM (as discussed below, most wind and solar resources today bid or schedule only in the real-time market through the schedule submission process that occurs hourly in advance of the operating hour). There is currently some limited day-ahead scheduling of wind resources, but little compared to expected next-day output. As the ISO sees additional wind and solar resources generation at higher RPS levels, this lack of day-ahead scheduling may lead to increased day-ahead over-commitment of thermal generation (to minimize the risk of a supply shortfall) and a

² These types of price-taker schedules, which can be submitted by supply and demand resources, are given a scheduling priority in the market, are price-takers for settlement purpose, and are only altered when the market is unable to clear based only on price-quantity bids.

³ In the RUC, for all Resource Adequacy capacity from resources obligated to make themselves available to the ISO, the capacity bid is set to \$0/MWh. Capacity without a Resource Adequacy obligation may bid into RUC at a price up to \$250/MWh.

⁴ See BPM for Reliability Requirements, available at <http://www.caiso.com/17ba/17baa8bc1ce20.html>.

divergence of prices between the day-ahead and real-time market. Hence, a need exists to change in the incentives for renewable resources to schedule day-ahead, or alternatively to encourage the participation in the forward market by financial entities that can anticipate next-day renewable output (i.e., convergence bidders).⁵ From an operational perspective, whether the day-ahead processes are modeled with or without full participation of variable energy resources is likely to be less problematic from an operational perspective than it would be for market functioning. Hence, the simulations conducted so far that analyze day-ahead processes assume that at least a forecast of wind and solar resources is considered in the day-ahead time-frame.

Following a procedure to mitigate generator bids for local market power if necessary, and to commit certain generation units that are needed for local reliability,⁶ the bids and schedules are co-optimized through IFM auction. “Co-optimized” means that the auction algorithm allows for the optimal use of a generator based on its Bids – to provide the most cost-effective mix of energy and ancillary services from its available capacity – in each hour of the day. The IFM results in day-ahead hourly schedules (i.e., a level of output for hour 1 to hour 24) for generators that submitted bids to the market and ensures that self-schedules are feasible. It also calculates locational marginal prices (LMP) for energy applicable to each generator location and averaged LMP for load in the service territories of the investor-owned utilities (and other entities that request such prices), called load aggregation points (LAP). Prices and schedules are determined simultaneously and reflect marginal congestion and marginal losses at each location. Results of the IFM are typically available by 1 PM.

After the IFM, the ISO conducts the first of several adjustments to the next-day schedule for energy and capacity in its RUC process. This uses the ISO’s next day load forecast for each hour and commits any additional resources needed. The ISO may adjust the RUC procurement target based on the ISO’s day-ahead forecast of wind and solar production,⁷ the ISO’s forecast of CAISO demand, and other expectations of system condition. Through this process, the ISO may commit additional (but not decommit) resources if it appears that insufficient supply was scheduled to meet the RUC procurement target. After the RUC process is conducted, and before the ISO begins the same-day real-time market procedures, the only way to decommit any over-scheduled supply is through Exceptional Dispatch. The RUC is the last formal step of the day-ahead process to prepare the power system for the operating day. Results of the RUC are also available by 1 PM.

Correspondence between Day-ahead Market Procedures and the Simulation Models

Each methodological appendix examines some aspects of how the renewable integration models correspond to actual market and scheduling processes. This section provides some initial observations on how day-ahead market procedures are considered. The statistical model described in Appendix B

⁵ Convergence bidding will begin in 2011.

⁶ Local reliability includes capacity requirements and transmission system requirements, such as voltage support, that must be provided by generators at particular locations on the grid. More information on local reliability assessment procedures and Reliability Must Run contracts can be found at <http://www.caiso.com/docs/2001/10/15/2001101510100413037.html>.

⁷ With the development of its improved day-ahead wind forecast, the ISO anticipates that the RUC process will be adjusted to compensate for expected wind output in the operating day.

does not currently evaluate day-ahead forecast errors when determining operational requirements. To do so would be a simple extension of the hourly portion of the model, by adding a step using day-ahead forecast errors before the current step using hour-ahead forecast errors. However, such an approach could overestimate the day-ahead requirements because it would not consider the ISO's ability to update forecasts and system conditions closer to real-time with sufficient time to undertake re-commitment of integration resources.

The day-ahead market auction design and constraints do correspond closely to the structure of the production simulation models, as described in Section D. These include the hourly time-step and the co-optimization of energy and ancillary service capacity reservations. Moreover, the stochastic elements of the statistical model can be incorporated into a production simulation model to evaluate the effect of day-ahead forecast errors on unit commitment, either through a capacity reservation to reflect intra-hourly requirements, or with a stochastic process that reflects day-ahead forecast errors. These options are also discussed in Section D.

There are some differences between the DAM structure and the production simulations. The production simulations described in Section D do not evaluate day-ahead bid-in load through the IFM and then conduct a RUC-like step. Instead, they are based on an hourly load forecast for the target year being evaluated. The IFM and RUC are thus considered jointly.

A further aspect of the production simulations is how the planning reserve margin capacity and Resource Adequacy designations are considered in the model. As discussed in Section D, for the initial 20% RPS study, all generation resources were modeled, whether they were Resource Adequacy resources or not. For subsequent iterations of the analysis, including the 33% RPS studies, modeling assumptions will include calculating operational capabilities of only Resource Adequacy resources.

A-2 Hour-Ahead and Real-Time Market (RTM) Scheduling Processes and Timelines

As shown in Figure 1, the day-ahead block hourly schedules that result from the IFM and the RUC become the starting point for the sequence of hour-ahead and real-time processes that run throughout the operating day. In the figure, the transition from the day-ahead schedule (blue line) to the hour-ahead schedule (green line) is the formal adjustment that reflects changes in system conditions and updated forecasts for load and renewable production and intertie schedules. The Hour-Ahead Scheduling Process (HASP) is the focal point for much of this hour-ahead adjustment (upward or downward), including the current hour-ahead renewable production forecasting process under the PIRP.

Following the hour-ahead scheduling processes is the Real-Time Market (RTM), which consists of the Real-Time Unit Commitment (RTUC) in which the ISO commits certain slower starting resources and awards real-time ancillary services requirements, and the Real-Time Economic Dispatch (RTED), which dispatches already committed resources and can run as either the Real-Time Manual Dispatch or Real-Time Contingency Dispatch. In addition, once an hour there a short-term unit commitment (STUC) process that can commit resources as far as 270 minutes ahead if necessary. As discussed further below, the real-time functions under normal operating conditions can be divided conceptually and analytically into load-following and regulation. These are shown in Figure 1 as the hour-ahead schedule plus load-

following increments (red line), and the additional deviations that reflect actual generation and load (black line), and which is met by Regulation. Load-following and regulation are defined further below.

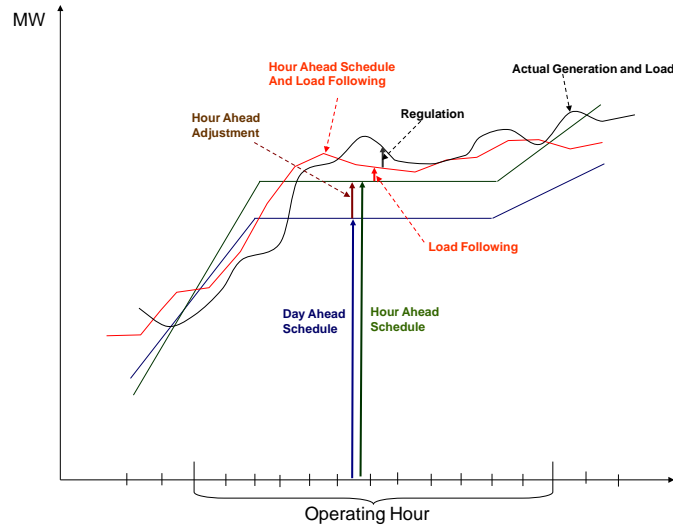

Figure 1: ISO Balancing Area Scheduling Process

Because of the importance of hour-ahead and real-time processes in operational modeling, the remainder of this section provides further details on timelines and assumptions. Beginning from day-ahead block hourly energy schedules, the HASP produces physically and financial binding hourly intertie schedules and settlement prices for hourly imports and exports to and from the ISO Balancing Authority (BA). Note that while internal demand cannot be bid into the HASP or RTM, hourly export bids can be submitted to and cleared in the HASP. Otherwise, real-time processes are all based on the ISO load forecasts and not bid-in demand.

Hour-ahead intertie bids and schedules are provided 75 minutes before the actual beginning of an operating hour. As shown in Figure 2, the block energy hour-ahead intertie schedules include the 20-minute ramps between the hours (10 minutes prior to and 10 minutes after the hourly boundary) following WECC practice. The load forecast used for the HASP is provided approximately 75 minutes before the beginning of an operating hour; this load forecast is nevertheless referred to as the “hour-ahead” load forecast in the remainder of these appendices. The difference between the day ahead and hour-ahead schedules constitute the required generation adjustment, as shown in Figure 1.

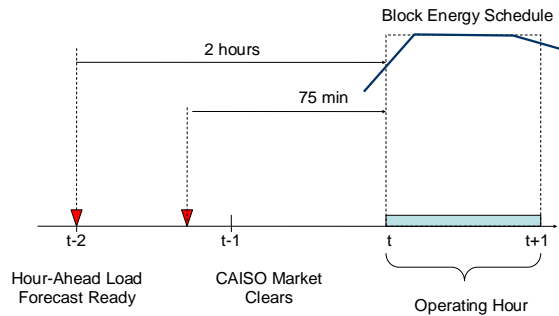

Figure 2: ISO Hour-Ahead Timeline

For variable energy resources that are in the PIRP, the CAISO makes available independent hourly forecasts of energy generation for each resource to the resource’s scheduling coordinator. These forecasts are provided and published each hour, 105 minutes before the operating hour for each of the next seven operating hours. The scheduling coordinator representing the PIRP resource must use the hour-ahead forecast that is available 30 minutes prior to the deadline for submitting their bids in the single bid-submission process for the hour-ahead scheduling process and real-time market. If the CAISO fails to deliver the hour-ahead forecast to the scheduling coordinator prior to 15 minutes before the deadline for submitting hour-ahead scheduling process and real-time market bids, then the scheduling coordinator must use the most recent energy forecast provided by the CAISO to the scheduling coordinator for the operating hour for which bids are next due. Scheduling coordinators are required to submit hour-ahead scheduling process and real-time market bids (MWh) for PIRP resources in the aggregate, to the hour-ahead forecast published for that PIRP resource (MWh). PIRP resources that schedule consistent with this forecast are entitled to a monthly averaging of locational marginal prices (LMPs) associated with their uninstructed imbalance energy deviations netted over the month -- as opposed to settlement of actual deviations at the actual LMPs. This enables such resources to smooth out the financial impact of output deviations, which are otherwise settled at real-time five minute LMPs.

The schematic in Figure 3 demonstrates the scheduling process for resources that participate in the PIRP. The schematic shows that the real time telemetry is collected every four seconds from the wind plant via the CAISO PI data collection system. The data is delivered to the PIRP application at the CAISO where this data, combined with the MW availability data for the resource, is sent to the forecast service provider by the top of every hour.

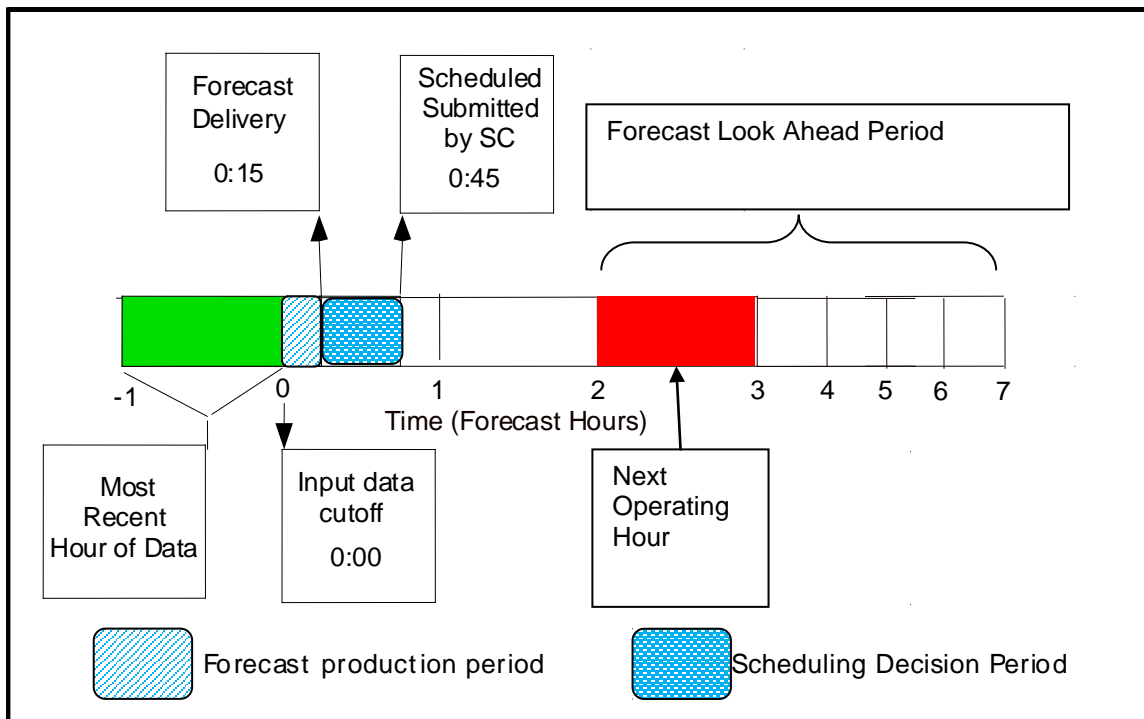

Figure 3: Schematic of the Production, Delivery and Usage Time Line for PIRP Next Operating Hour Forecast

Following the HASP, the ISO conducts several further RTM applications that continuously adjust commitment prior to economic dispatch every 15 minutes. The unit commitment processes in the RTM applications consist of the Short Term Unit Commitment (STUC) and Real Time Unit Commitment (RTUC). Resources that have not self-scheduled above their minimum operating level can be shut down and start-up within the solution horizon of the RTM processes may be committed⁸ or decommitted⁹ during the execution of STUC or RTUC to maintain a load resource balance, maintain adequate operating reserves and meet hourly ramps. The STUC is run once every hour to commit resources that have start up times greater than 90 minutes or up times greater than 270 minutes. The current RTUC application runs every 15 minutes and solves for power flow and security unit commitment analysis four to eighteen intervals ahead to determine whether short-start and fast-start

⁸ Issued a start-up instruction and dispatched to its minimum operating level (Pmin).

⁹ Issued a shut-down instruction.

units need to be committed or de-committed. In addition to commitment decision, the RTUC process simultaneously optimizes energy and ancillary services and produces binding ancillary service awards for the next 15 minute time interval. Such ancillary service awards are binding when RTED is performed for energy every 5 minutes.

At time t , RTUC is executed for interval beginning $t + 30$. Although RTED executes on a 5-minute basis, ramping is limited to the capability of the committed resources. The minimum and maximum ramping capabilities for interval t are determined by the actual operational ramp rates¹⁰ of resources committed prior to interval t . Should net load increase beyond the upper limit, the committed resources would not be able to meet the additional demand until additional resources are committed through RTUC; should net load decrease beyond the lower limit, the committed resources would violate ramp constraints. For more detail on these calculations, see Appendix E. The outcome of the RTUC is a set of unit commitment instructions for each of the intervals.

The RTED then produces a security constrained economic dispatch of energy from resources that are dispatchable within the five minute interval, including resources pre-committed in prior market runs, and while not dispatching awarded ancillary services that have been designated reserved for a contingency or for regulation. While some awarded operating reserves that have been designated and “non-contingent” may be converted to energy in RTED, once the minimum operating reserve requirements become binding in real-time, operators will cease to dispatch additional energy from capacity that has been awarded spin or non-spinning reserves unless a contingency were to occur. RTED is dispatching to meet expected conditions not potential conditions due forecast error and variability. Therefore, there currently is no formal reserve or constraint to ensure that sufficient flexible capacity is committed to account for forecast error or variability. In the event that there are short-term ramping deficiencies due to forecast error or other variability in RTED, available resources will be dispatched as far as they can based on their ramping capability and in the event that their ramp capability is exhausted, spot prices will spike to reflect deficiency.

The desired changes of generation are determined in real time for each five-minute dispatch interval 7.5 minutes before the actual beginning of the 5-minute interval. The RTED process runs automatically every 5 minutes and looks out as many as thirteen intervals including the 20-minute ramp shown in Figure 2. RTED can also be executed by the market operator in manual (RTMD) or contingency dispatch (RTCD) mode. RTED will dispatch resources off their projected output which is projected based on the resources’ current State-Estimator or Telemetry level as shown in Figure 4.

¹⁰ The operational ramp rate of the resource may have up to 4 different ramp-rates for different registered operating ranges between its minimum operating level (Pmin) and its maximum operating level (Pmax). In addition a resource may have up to 4 forbidden operating regions with each forbidden operating region having its own transit time through the forbidden operating region.

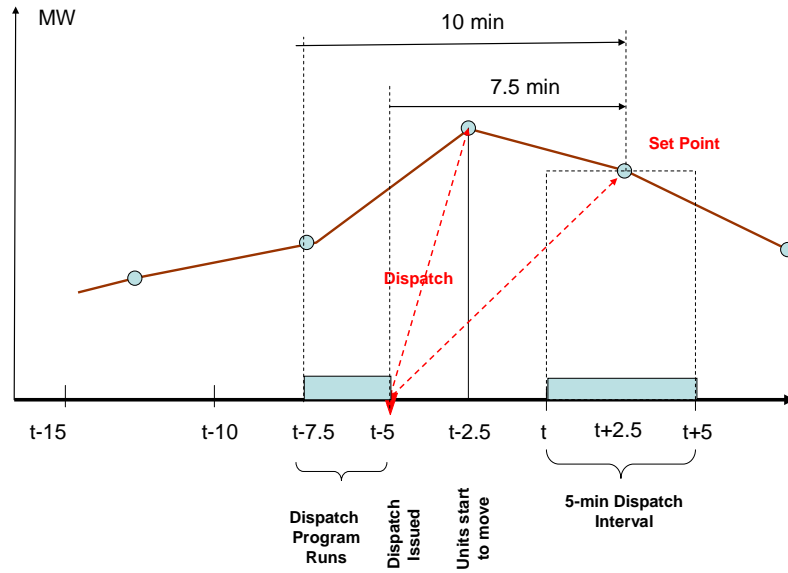

Figure 4: ISO Real Time Dispatch Timeline

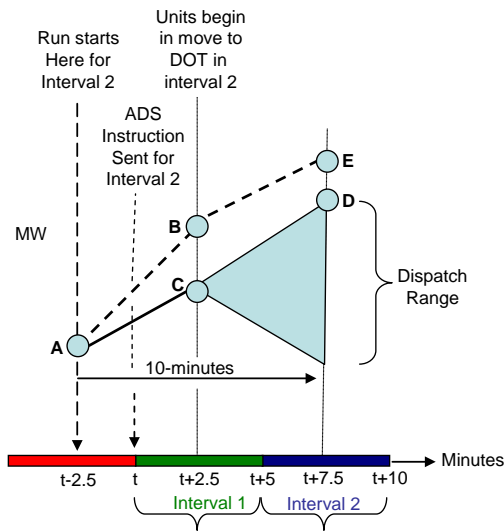

Figure 5: RTED Dispatch Ramping Projection

Figure 5 illustrates uninstructed deviations, a feature of the dispatch process that will become more significant with higher levels of variable energy resource production, but which is difficult to model in simulations. In Figure 5, the resource’s instruction for the mid-point of dispatch interval 1, $t+2.5$, was to move from its actual operating level at Position A in the mid-point of the prior interval, to Position B in interval 1. The RTED application checks to see whether the resource can reach position B as previously instructed from its current state-estimator or telemetry level. If the RTED determines that the resource can only reach Position C (which was not the new dispatch operating target) based on its ramp rate, RTED calculates the resource’s new operating point for interval 2 starting from Position C (initial

condition). The resource can only move up to Position D, rather than move from Position B to Position E. This helps to avoid uninstructed deviations (difference between point E and point D).

The actual ramping requirement for RTM operation varies in both the positive and negative directions for any given hour. This is due to many factors including the hourly schedule changes for generation self-scheduling and hourly block ties schedules and load schedules submitted in the ISO market systems. Hourly self-generation and ties schedules awarded in the RTM are done over a 20-minute ramping period between hours.

While self-scheduled generators with no bid price curves are dispatched to meet their next hour schedules over a period of time from 20 to 60 minutes depending on the resources ramp-rate, other generators with bid price curves may have to be moved in the opposite direction on a 5-minute basis through the RTED application to maintain a balance between generation and 5-minute load forecast.

Conventional resources dispatched through the RTM applications are moved to different operating levels based on optimization of economics, ramp rates, actual operating conditions and imbalance energy requirement. In spite of 5-minute RTED, operational challenges do exist in predicting the requirement of imbalance energy, especially when units are not following their instructions or schedules; inability of external BAs meeting their forward interchange schedule, and variability associated with renewable resources.

In addition to the above mentioned challenges, several operating constraints do exist that can inhibit the ramping capabilities across the 20 to 60 minute ramp period from one hour to the next.

Non-dispatchable resources such as wind generation contribute to uninstructed deviations because wind production levels can change significantly from Point A to Point D in Figure 5. Conventional resources are expected to remain at their operating level at Point A if the resources are not instructed to move to new operating levels. Typically, wind generation resources only submit their hourly schedules in the HASP. Since wind generation output changes frequently and significantly, the hourly schedule of wind generation does not represent the actual wind generation. The dispatch of conventional resources cannot accurately reflect the actual output of wind generation because dispatch decisions are made 10-minutes prior to the end of subsequent dispatch interval.

Relationship of economic dispatch (load-following) and regulation

Generally, the objective of the RTM is system balancing and load following on a forward looking basis above and beyond the normal function of the Automatic Generation Control (AGC). The capacity under AGC is referred to as regulating reserve or regulation.¹¹ Since the RTM is forward-looking, AGC is mainly a control rather than an energy service. As AGC units depart from their Dispatch Operating Target (DOT) established by the RTED process by responding to frequency and net interchange deviations, they temporarily supply or consume balancing energy. The RTED function dispatches ahead of AGC, while AGC resolves shorter-term imbalances. The schedule deviations in the real-time are classified into either “instructed” or “uninstructed” imbalance energy. Instructed deviations are the

¹¹ The WECC defines Regulating Reserve as sufficient spinning reserve, immediately responsive to automatic generation control (AGC) to provide sufficient regulating margin to allow the control area to meet NERC’s Control Performance Criteria.

result of participating resources responding to ISO Dispatch Instructions and are usually price setters. Uninstructed imbalance energy may be the result of load forecast errors, Forced Outages, contingencies, strategic behavior, modeling limitations, failure to follow Dispatch Instructions, and so on. AGC response itself is also classified as uninstructed energy as such AGC dispatches are not the result of expected market imbalances. Uninstructed deviations may prompt the response of AGC to balance the system, creating Imbalance Energy requirements that are met through instructed deviations calculated optimally by the RTM and settled as price-takers. Further definition of the distinction between load-following and regulation for purposes of simulation is provided in Section C.

Reliability Standards

A key constraint in actual system operations, and one that should also be reflected in the accuracy of the simulated operating conditions are reliability standards. In actual operations, the ISO will have some unintentional outflow or inflow of energy into its BAA at any given instant. The mismatch in meeting a balancing authority's internal obligations, along with a small obligation to maintain frequency, is measured via an instantaneous value called Area Control Error (ACE), measured in MW. The North American Electric Reliability Corporation (NERC) control performance standards are intended to be the indicator of sufficiency of secondary control. Overgeneration makes ACE go positive and the frequency increases. A large negative ACE causes frequency to drop. NERC Control Performance Standards (CPS1 and CPS2¹²) capture these relationships. In simple terms, CPS1 assigns each balancing area a slice of the responsibility for control of the interconnection frequency. The amount of responsibility is directly related to the size of the BAA. CPS2 is a statistical measure of ACE over all 10-minute periods in a month. Under CPS2, ACE is limited to a regulating range whose width is proportional to the BAA's size.

The ISO monitors ACE and attempts to keep the value within specified limits. This is accomplished through a combination of automatic generator adjustments, manual dispatch and sales and purchases from neighboring balancing authorities. The ISO maintains sufficient generating capacity, both in the up and down direction, under automatic generation control (AGC) within the energy management systems (EMS) to continuously balance generation and interchange schedules with real time load.¹³ Although the regulation dispatch is done every four seconds, the regulation margin has to be adequate to meet deviations within a 5-minute dispatch interval.

Wind and solar generation vary on a minute-by-minute basis. The variability in wind and solar generation, coupled with the variability in load, will have an impact both on regulation and load-following requirements. The uncertainty in wind and solar generation increases the system operator's need to reserve capacity for wider ranges of regulation and load-following capability than would otherwise be needed if they had full certainty about the actual variability. Uncertainty in the day-ahead timeframe may lead to a unit commitment with inadequate regulation and load-following capability that is required in real-time. The lack of regulation and load-following capability may have an impact on ACE, and if sustained, result in a CPS2 violation. Under extreme cases, the lack of regulation and load-

¹² The CAISO is currently not subject to CPS2 performance criteria while it is in a trial period for Reliability Based Control.

¹³ The WECC defines AGC as equipment that automatically adjusts a control area's generation from a central location to maintain its interchange schedule plus frequency bias.

following down capability might require the curtailment of generation to keep ACE within specified limits.

An important caveat is that the CAISO is currently operating under a WECC Reliability-Based Control (RBC) field trial. Under RBC, there is recognition whether a Balancing Authority ACE is supporting interconnection frequency, whereas CPS2 does not. Therefore, in cases where the Balancing Authority ACE is supporting the interconnection, RBC is less restrictive than CPS2. However, under RBC, the Balancing Authority ACE Limit (BAAL) becomes increasingly more restrictive than the corresponding CPS2 L10 as Interconnection frequency deviates further from 60 Hz.

Correspondence between Real-Time Market Procedures and the Simulation Models

Real-time operations are clearly more complex than day-ahead market and scheduling processes. The simulation models attempt to capture real-time market processes in two ways:

- Statistical modeling of load-following and regulation, including ramp requirements (Step 1)
- Production simulation of the transition from hour-ahead unit commitment to real-time dispatch on 5-minute intervals (Step 2)

As discussed in Appendix C-1, the statistical model incorporates both load forecast data and a wind and solar persistence forecast model to derive deviations between the hour-ahead schedule and the 5-minute dispatch schedules.

The production simulations on a 5-minute basis begin from a realistic unit commitment that captures forecast errors. However, given their scale, the simulations cannot fully capture the rolling unit commitment process that is actually undertaken by the ISO, nor the effect of intra-hourly forecast errors. The ISO anticipates that other types of detailed real-time simulations will be helpful in capturing some of these constraints.

SECTION B

Section B covers two aspects of the modeling: the development of load and wind/solar production profiles for the base-year and target years, and the analysis of forecast errors for those years. Appendix B-1 examines the selection of the target year for analysis. Appendices B-2 to B-5 discuss the development of the load and wind/solar production profiles, building from 1-minute data to other levels of aggregation. Appendices B-6 to B-9 examine the development of forecast errors for load, wind production and solar production. The simulation studies have used forecast errors in two ways: the statistical modeling of deviations from schedules described in Appendix C; and the development of load and wind forecasts that reflect forecast uncertainty for use in production simulation, described in Appendix D.

Appendix B-10 discusses assumptions about improvements in forecast errors. The ISO is dedicated to continuous improvements in its day-ahead to real-time forecasts of wind and solar production. Recent evaluations by the ISO of the state-of-the-art in wind forecasting have demonstrated that such improvements can be significant.¹⁴ The ISO has also sought to review and improve solar forecasting in anticipation of increases in solar production.¹⁵ For simulations up to 10 years hence, it is thus reasonable to assume some level of forecast improvement. In addition, as discussed below, the statistical modeling can evaluate cases with no forecast error to measure the relative contributions of forecast errors and actual variability to operational requirements.

B-1 Selection of Target Year for Analysis

In each study, the ISO will select one or more “target years” for evaluation that correspond to regulatory and/or legislative RPS requirements as well as judgment about the actual, RPS-eligible, in-state and out-of-state variable energy production in those years. The ISO will typically also select a baseline year for comparison purposes (as well as sensitivities about system conditions in the target year).

The ISO will consult with the CPUC and other entities to determine the likely renewable production in different years. The California 20 percent RPS is currently established for a target year of 2010. Load-serving entities are expected to achieve this goal by 2012, and perhaps earlier, depending on load growth, contract implementation, and other factors.¹⁶

¹⁴ CAISO, *Revised Analysis of June 2008 – June 2009 Forecast Service Provider RFB Performance*, March 25, 2010, available at <http://www.aiso.com/2765/2765e6ad327c0.pdf>.

¹⁵ See papers and presentations at <http://www.aiso.com/1817/181783ae9a90.html>

¹⁶ California Public Utilities Code Section 399 requires that the RPS objectives be achieved by 2010, with some accommodation for deferred compliance under specified circumstances. In 2009, the California investor-owned utilities served 15.4 percent of their load with renewable energy eligible under the RPS. In late 2009, the California Public Utilities Commission (CPUC) estimated that the 2010 deadline would not be met and that 2013-14 was more realistic. However, in mid-2010, based on declines in electricity consumption, rapid growth in RPS contract approvals (including short-term contracts for out-of-state wind energy), and other factors, the CPUC estimated that the 20 percent target could be reached in 2011. In this study, the ISO models 20 percent renewable

The California 33 percent RPS is set through executive order for a target year of 2020, coincident with the target year for AB32.

The ISO may also select other target years for subsequent analysis, or model the target years at less than full RPS, to examine sensitivity of the results to the mix of renewable resources as well as the conventional resources forecast to be on the system.

B-2 Load Forecast and Profiling for Target Year

The load forecast for the target year will be function of the load in the baseline year and an assumed growth rate for load up to the target year.

For example, a future study year with the baseline of 2006, such that the study year is $2006 + i$, where i indicates the addition of i years, the annual actual load curve can be simulated as the year 2006 load multiplied by the i -th power of the annual load growth factor:

$$L_a^{2006+i} = (1 + \gamma)^i \times L_a^{2006} \quad (1)$$

Actual one-minute resolution load data from the baseline year will be used for each study, but the target year simulation may require further shaping of the load curves depending on the resolution of the simulation (i.e., 5-minute, one-hour). The annual growth factor will be specified for each study and may be varied to provide sensitivity analysis.

B-3 Determination of Renewable Resource Portfolios and “Net Short” Renewable Energy

The ISO will typically use renewable resource portfolios that correspond to the objectives of the study, whether short-term (e.g., 1-3 years ahead) or longer-term (e.g., the 33% RPS in 2020 studies). The short-term renewable portfolios will typically be comprised of existing resources and those considered highly likely for interconnection and operation by the target date, based on ISO and CPUC data. The longer-term studies are likely to use renewable resource portfolios determined through cases developed for the CPUC long-term procurement proceeding,¹⁷ ISO transmission planning, and other sources. The

energy in 2012. See CPUC, Renewables Portfolio Standard, Quarterly Report (Q4 2009), at p.4, and CPUC, Renewables Portfolio Standard, Quarterly Report (2nd Quarter 2010), at p. 3, both available at <http://www.cpuc.ca.gov/PUC/energy/Renewables/documents.htm>.

¹⁷ The 33% RPS renewable portfolios are described in the presentation at http://www.cpuc.ca.gov/PUC/energy/Renewables/100824_workshop.htm.

renewable resource portfolios are typically characterized by technology type, location (internal and external to California), capacity (MW) and energy (MWh).

The renewable “net short” refers to the incremental renewable energy (MWh) required to achieve the RPS objective for the target year. As such, the renewable portfolios modeled for the target year are shaped, through adjustments of assumed installed capacity (MW), capacity factors (MW/year) and energy (GWh) to achieve the net short. Since this shaping is an assumption, actual renewable production may be greater or less than is modeled. Because the net short calculation typically includes assumptions about load forecasts (including energy efficiency goals), production by behind-the-meter renewable resources, total combined heat and power, and other factors, the ISO will typically aim to adopt calculations of the net short by the CEC, CPUC, RETI or other entities contributing to the development of future scenarios.

B-4 Wind Generation Profile for Target Year

The ISO has developed different wind generation profiles for its 20% RPS studies and its 33% RPS studies.

Wind Generation Profiles for the 20% RPS Study

This section describes the development of wind generation profiles for new wind plants for use in both the statistical simulations and the production simulations of the CAISO 20% RPS Studies. This consists largely of information provided in Appendix D of the ISO’s 2007 Report, with some editing. The same wind generation profiles were used for the ISO’s 2010 study of 20% RPS, as their production was sufficient to reflect expected production in 2012.

Scaling Wind for the 20% RPS

Simply scaling the 2006 actual wind production by the ratio of the expected capacity to the current capacity fails to take into account any local weather variation within a resource area. This methodology would also neglect any benefits of aggregation, which will reduce overall variability. To remedy some of the problems with direct scaling, the following methodology was used.

The 20% RPS energy production and minute-to-minute variability were calculated separately. The reason for calculating the expected production separately stems from the fact that wind energy production and variability during short time intervals are often driven by separate phenomenon. For the analysis, three new wind parks totaling 3,540 MW were assumed to be located in the Tehachapi area and a new 500 MW wind park located in the Solano area. The other existing wind parks were assumed to remain the same as in 2006 (note that these expansion assumptions remain sufficient for the 2010 study).

Wind Energy Production

The 20% RPS hourly energy production data for the Tehachapi and Solano regions were generated by AWS Truepower using actual production data from January 2002 through December 2004 combined

with atmospheric simulation models to create wind speeds for the resource areas. AWS Truepower then extracted production values based on the resource area conditions with local corrections for each site and the expected power curve. The initial dataset is comprised of hourly block energy forecasts for each of the existing and expected wind parks in the Tehachapi and Solano areas. As shown in Figure 6, 20-minute linear inter-hour ramps were added to this original dataset to smooth the overall shape, and to prevent changes between hours from introducing artificial variation. There is further discussion of the inter-hourly ramp assumptions in Appendix C.

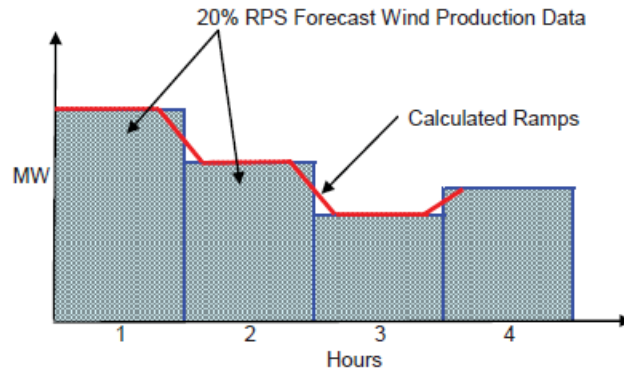

Figure 6: Expected Wind Energy Production with Linear Ramps

Minute-to-Minute Variability

The minute-to-minute variability in the data set is the actual minute-to-minute variation observed from the existing wind production in the various resource areas for 2006. The minute-to-minute variations are defined as the 1-minute deviation from a 60-minute centered moving average. Using a centered moving average takes out the longer term trends in the wind production (i.e., ramping up in the evening or down in the morning). A 60-minute average was used to closely match the energy given as hourly blocks. Figure 7 shows a sample of wind production and a comparison between the hourly average and the moving average. Since the 20% RPS energy production values are not based on the 2006 wind production data, it can at times have opposite inter-hour trends. These opposite trends could exacerbate the variability if it were taken from fixed hourly averages of 2006 data and then combined directly onto the expected production. Figure 8 shows how the inter-hour trends in energy can be different between the two datasets.

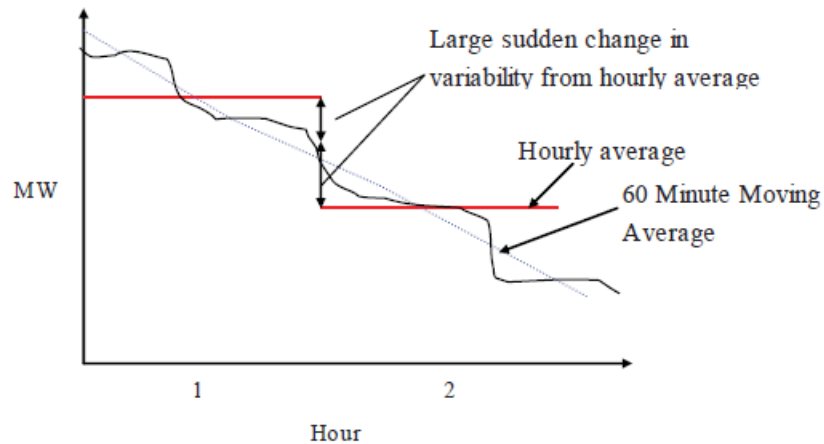

Figure 7: Sample Wind Production with Hourly Average and Moving Average

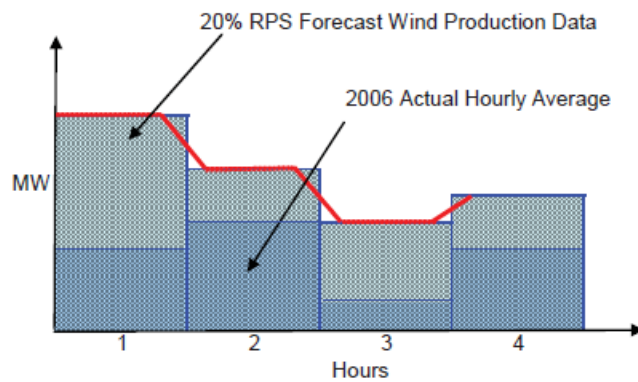

Figure 8: Possible Average Wind Generation Pattern

The variability was then scaled up assuming that new wind farms would have similar levels of variability and that short-term variations would be completely uncorrelated. Figure 9 and Figure 10 show the correlation coefficient of short-term fluctuations of Solano and Tehachapi wind parks, and shows there is no significant correlation. The correlation coefficient is a measure of the extent that two variables are changing together. It is bounded between 1 and -1. If it has a value of 1, the two variables always change together in the same direction, if it has a value of -1, they change in opposite directions. If the correlation coefficient is 0, the two variables vary completely independently of each other. The equation for the correlation coefficient is shown below:

$$Correlation = \frac{\sum_1^N (X - \mu_X)(Y - \mu_Y)}{(N - 1)\sigma_X\sigma_Y}$$

Where:

N is the number of data points,
 X is a variable,
 Y is a variable,
 μ is the average value of the data,
 σ is the standard deviation of the data.

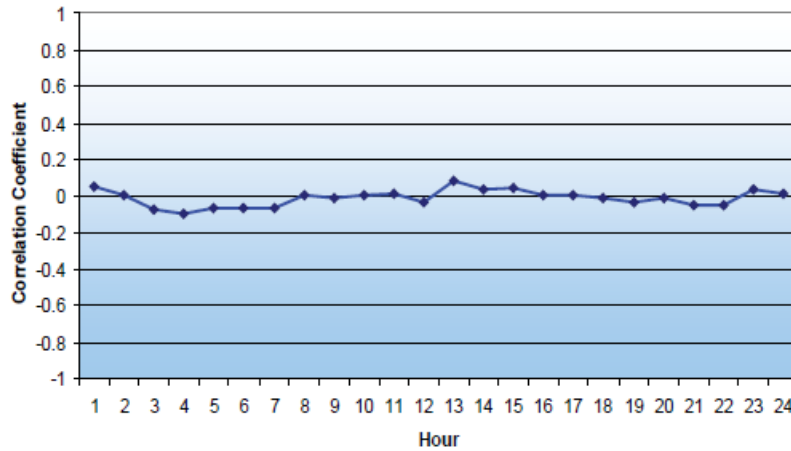

Figure 9: Correlation of Short-Term Variations of Wind Parks in Solano and Tehachapi, May 2006

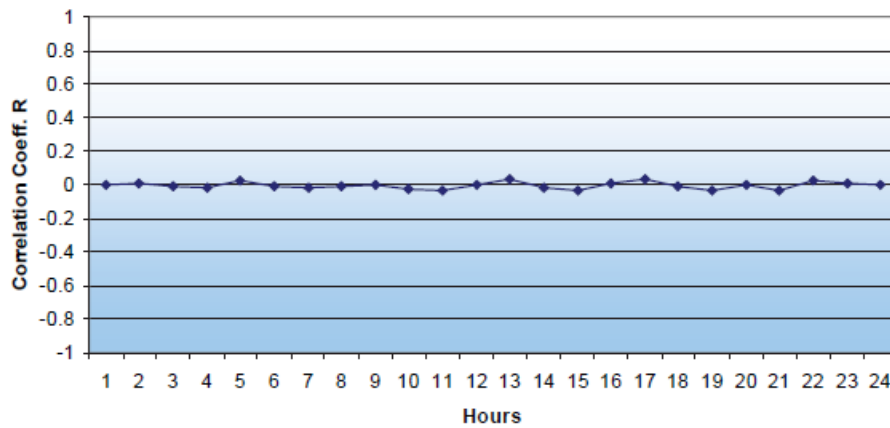

Figure 10: Correlation of Short-Term Variations of Two Wind Parks in Tehachapi Resource Area, May 2006

Since the variability of the parks is independent, the standard deviations are added together as the square root of the sum of the squares. The scale factor γ is then determined by calculating the expected standard deviation in the target year (2010 in the original data set) and dividing that by the current standard deviation:

$$\gamma = \frac{\sqrt{\frac{MW_{2010}}{MW_{2006}} \sigma^2}}{\sigma} = \sqrt{\frac{MW_{2010}}{MW_{2006}}}$$

The minute-to-minute variation is then multiplied by this scaling factor for each minute to get the expected variability.

A feature of the 20% RPS wind data set is that the variability from one of the newer wind parks in 2007 and the wind parks connected to the Vincent substation were analyzed separately. These two wind parks were used in the analysis because real-time telemetry from these sites are updated and sent to the ISO every 4 seconds. The newer wind park (60 MW) is made up of newer wind turbines, and it was assumed that future additions will behave similarly to the turbines installed at this park. Thus, the scaling was split so that the newer wind park minute-to-minute variability was scaled such that it represents 75% of the expected Tehachapi addition. The Vincent substation variability was scaled to represent the remaining 25%. The scaled variabilities were added together minute-by-minute to give the total Tehachapi distribution. A similar method was used in the Solano area. For the Solano area, the two newest wind parks analyzed. Since both of these parks have relatively new wind turbine technology, an equal weight (50%) was placed on the variability of each. Finally, the energy component and the 1-minute variability were added together to give the 1-minute wind production values.

Note that this data set was not used in the 33% RPS simulations discussed next.

Wind Generation Profiles for the 33% RPS Studies

This section describes the development of wind generation profiles for new wind plants for use in both the statistical simulations and the production simulations of the CAISO 33% RPS Studies. Both types of analysis used wind generation profiles that were developed based upon NREL mesoscale wind data for 2005¹⁸ but on different time-steps; the statistical analysis uses 1-minute synthesized production data for each wind plant and location while the production simulation uses hourly production data, averaged from the 1-minute data, for these same plants/sites.

For new plants, wind plant production modeling was based upon NREL 10 minute data production data from the year 2005 for 17 distinct locations in California and 12 distinct locations throughout the remainder of the WECC where wind plants were identified in the CPUC study cases.¹⁹ The 10 minute production data from these sites were used to develop 1 minute data as described below and then averaged to produce hourly²⁰ data.

¹⁸ Data for the year 2005 was used in the ISO 33% RPS Studies because 2005 was designated as a normal hydro year. Thus load, wind, solar and hydro run of river profiles were based upon conditions (wind speeds, solar irradiance, and hydro flows) that existed in 2005.

¹⁹ NREL production data is based upon a wind farm using Vestas V-90 3 MW generators.

²⁰ Hourly wind data was developed by averaging the 10 minute production data obtained from the NREL website after Step 4 was completed.

Synthesis of 1 Minute Wind Data for Renewable Generation Additions

The 1 minute wind data used for all new wind plants was developed using a methodology that included the following steps or processes:

First, a representative number of plants and their geographical location are developed whose total capacity (MW) match the MW in each CREZ in the study definition. For the 33% RPS studies, the study definitions were based upon the resources included in each of the scenarios studied by the CPUC (see Appendix B-3). The process to identify the number of units and locations for the projected additions used as a starting point CPUC data from the procurement processes of the three investor owned utilities (PG&E, SCE and SDG&E) and generic plant information from the RETI process.

Second, GIS software was used to find one or more appropriate NREL data sites for each CREZ to represent wind plants in that CREZ. Multiple NREL data sets within a CREZ were used to capture the diversity within a CREZ where there were multiple plants within a CREZ in the study definition. In selecting the NREL points to use from among the many NREL mesoscale points available, care was taken to select wind sites that represented likely sites for wind farms (ridge location, etc.) and that had capacity factors that were as close as possible to the plants specified in the case definitions.²¹

Third, the 10 minute production data sets for the selected sites were downloaded from the NREL website. These data sets were then shifted in time to Pacific Standard Time and then the days of the week were shifted to match the days of the week for the study year – 2020.²²

Fourth, the resultant data was adjusted, if needed, if there were any capacity factors that did not closely match the study definition plant capacity factors. These adjustments were minimal since the data sets were chosen to closely match the desired capacity factors.

Fifth, the 10 minute production data for each site was curve fit with a cubic spline curve fit function to produce 1 minute data without 1 minute variability.

Sixth, a statistical model was developed using historical ISO data from several existing wind farms to capture the 1 minute variability (compared to a 10 minute average) as a function of the size of the plant/wind farm. This statistical model captures the standard deviation of the 1 minute variability as it varies with wind farm size.

Finally, using this 1 minute statistical model, variability was then added to each 1 minute splined set of data using a process that adds variability randomly as function of the wind farm size.

The final data set of 1 minute wind farm data for each plant, which includes 1 minute variability, was then used for the statistical model of operational requirements, described in Appendix C.

²¹ The NREL mesoscale data that was used can be found at http://wind.nrel.gov/Web_nrel/.

²² Shifting data to match days of the week in the study target year allow comparison of weekday and weekend results.

B-5 Solar Generation Profile for Target Year

This appendix describes the development of solar generation profiles for use in both the statistical simulations described in Appendix C and the production simulations described in Appendix D. Both types of analysis use solar generation profiles that were developed based upon NREL irradiation data but on different time-steps; as with the wind and load data, the statistical simulation uses 1-minute synthesized production data for each solar technology type and location while the production simulation uses hourly production data for these same sites.

Synthesis of 1 Minute Solar Data for Renewable Generation Additions

The 1 minute solar data used for all new solar plants was developed using a methodology that includes the following steps or processes:

First, a representative number of plants and their geographical orientation are developed whose totals match the technology and number of MWs in each CREZ in the study definition. The process to identify the number of units, types and locations for the projected additions uses as a starting point the renewable additions identified as per the renewable portfolios being modeled and assumptions about the renewable net short.

Second, selected representative hourly solar irradiance data points available in the 2005 NREL solar data set¹ for each CREZ.

Third, hourly production data was developed for a nominal 1 MW plant for the appropriate technology in each CREZ using hourly average NREL irradiation data sets for 2005 for each CREZ as input to the NREL Solar Advisory Model (SAM). The SAM model was used to develop production data for three types of technologies – Solar PV with tracking, Solar PV without tracking and Solar Thermal which used the trough model within SAM.

Fourth, 1 minute production data was synthesized from the 1 MW plant hourly production data using a smooth cubic spline curve fitting function. This data did not yet represent the minute to minute production variability that can be present in the output of solar plants due to clouds or other factors. What it does represent is a 1 MW plant that is essentially a plant at a single point.

Fifth, variability was introduced into the smoothed 1 MW, 1 minute plant production data using a process that inserted the variability captured from historical 1 minute irradiance data from measurements made by SMUD. At this stage in the process, the 1 minute data captures the variability of a 1 MW plant that is concentrated at one point. This step is discussed in more detail below.

Sixth, for CREZs that have more than one plant with the same technology, the 1 minute data was shifted in time to represent the time that clouds would take to traverse across the plants in the CREZ. To determine the appropriate time shift, historical cloud speeds at an elevation of 1,000 meters across a broad number of sites in California over a fifteen year period were used. These cloud speeds are shown

¹ NREL data set can be found at http://mercator.nrel.gov/prospector_beta/.

in Table 2. At this stage we have 1 MW production data for all plants that captures their geographical relationship to other the plants within a CREZ.

Seventh, plant physical size is considered next as the single point production data is processed using a moving average algorithm and scaled up to its actual MW rating. At this stage we have 1 minute generation data for a scaled up plant as listed, e.g., in Table 1. The land area required for various solar technologies is shown in Table 3.

Eighth, to reflect the fact that certain technologies have inherent time delays in their response to changes in irradiance, the data described in step 7 is processed in an inertial delay algorithm to arrive at the final 1 minute production data. This step is applied only to solar thermal plants as it is believe that solar PV plants have negligible time delay in their response to changes in irradiance. For the three types of solar thermal technologies (trough, tower and Stirling) three different characteristics were used as shown in Figure 11.

Table 1: New Solar Plants Modeled in the 20% 2012 Study

CREZ	Solar Thermal	Solar PV
Barstow	96 MW	
Riverside East 1	450 MW	460 MW
Riverside East 2	450 MW	
Mountain Pass/Tehachapi		180 MW
Distributed Solar		190 MW

Table 2: Monthly Cloud Speeds

Month	Miles/Hour
January	19
February	21
March	18
April	17
May	15
June	12
July	11
August	10
September	11
October	15
November	17

December	19
----------	----

Table 3: Plant Area by Technology

Plant Technology	Area Required in Kilometers for 10 MW Facility
Solar Thermal	0.0855 Square Miles ²
Solar PV without Tracking	0.093 Square Miles
Solar PV with Tracking	0.093 Square Miles

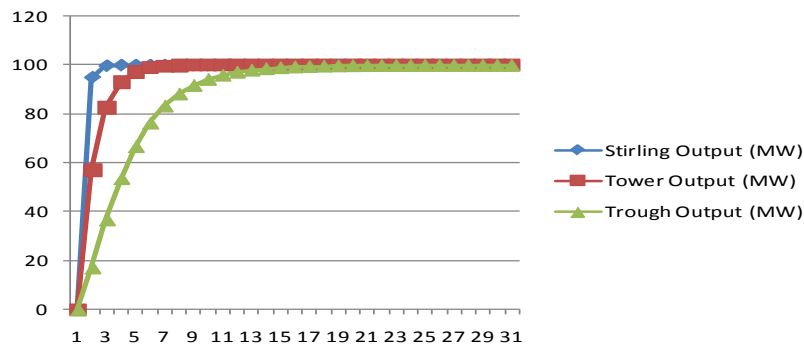

Figure 11: Response to Step Increase in Irradiance by Solar Thermal Technology vs. Time in Minutes

Description of the Step Used to Introduce 1 Minute Solar Variability

In Step 5 above, the process used to introduce 1 minute variability into the smoothed 1 minute production data is referred to. This step in turn is made up of several steps as described below:

First, a Data Library was developed of 1 minute variability from historical 1 minute irradiance data collected by Sacramento Municipal Utility District (SMUD). A summary plot of this raw historical irradiance data (in W/M²) is shown in Figure 12.

Second, this 1 minute data was converted to a normalized derate value by dividing the 1 minute actual irradiance data by the irradiance measurement that would have existed had there been no clouds in that minute. The resulting data was a set of 1 minute historical per unit irradiance derate values that ranged from 0 to 1.0, with 0 representing full reduction from a clear sky level to a zero irradiance level and 1.0 representing no reduction from a clear sky level.

² Average of solar thermal tower and trough technology.

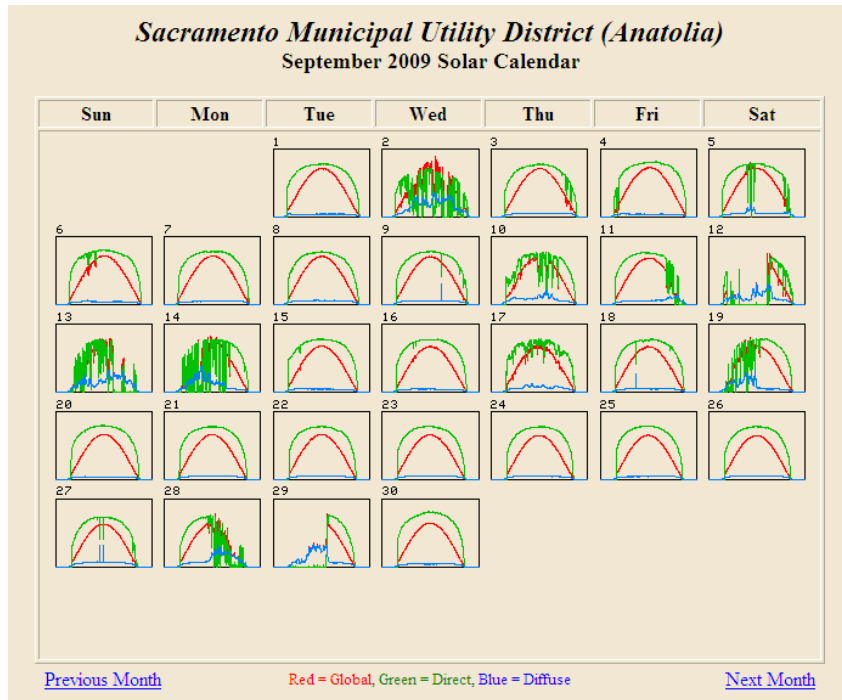

Figure 12: SMUD 1 Minute Irradiance Data for September 2009

Note: From this plot, it can be seen that some days have little variability and other days have significant variability. Figure 13 shows the variability of a single day.

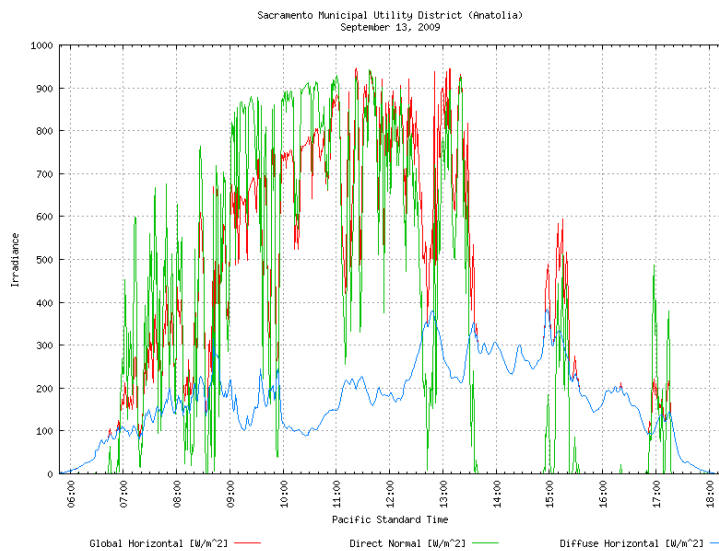

Figure 13: 1 Minute Irradiance for September 13, 2009

To capture the fact that some hours are cloudless and other hours have clouds which reduce the irradiance below its clear or cloudless sky level, variability was added to only those hours of production which show cloud cover impacts. This was accomplished by first converting the 1 minute smoothed production data from the 1 MW plant into 1 minute derate values that ranged from 0 to 1.0 similar to the 1 minute derate values in the irradiance data library discussed earlier. This was accomplished by dividing the smoothed 1 minute generation by the 1 minute generation that would have been produced if there were no clouds in that minute.

Next, average production derate values were calculated on an hourly basis from the 1 minute derate values. Then for each hour of the year that had a derate value lower than x.x, the 1 minute production derate values were replaced by an hour of irradiance derate values from the library developed that had the same hourly derate value. This step added variability based upon historical data to the 1 minute production derate values while maintaining the average derate over the hour at the same level as in the production data.

The following further checks were conducted:

- To ensure that there were no significant step changes caused by the derate data substitution, the start minute and end minute derate values were tested to make sure they were within certain tolerances compared to neighboring points.
- To ensure that historical data was as representative as possible, substitution data was required to come from hours in the library that were within +/- 2 hours. Thus afternoon variability would not be applied to morning hours.
- To increase the number of library “hours” available for substitution, sets of 60 1 minute values (library hours) were created by shifting the start of the 60 minute period by 1 minute. Thus data from 2 hours could be used to construct 60 library hours.
- To ensure that a bias was not introduced in the substitution process, a random selection process was used to find the derate data that met the end effects tolerances.

This hourly process proceeded through the entire year to develop a full year of 1 minute production derate values.

The final step converted the derate values into 1 minute production values by multiplying the derate values by the 1 minute production expected from a 1 MW plant under clear sky conditions.

The results of this process is shown graphically in the figures below. Figure 14 shows the hourly production data output of the SAM model for May 16, 2020. Figure 15 shows the smoothed 1 minute production data and Figure 16 shows the production data after historical variability has been added.

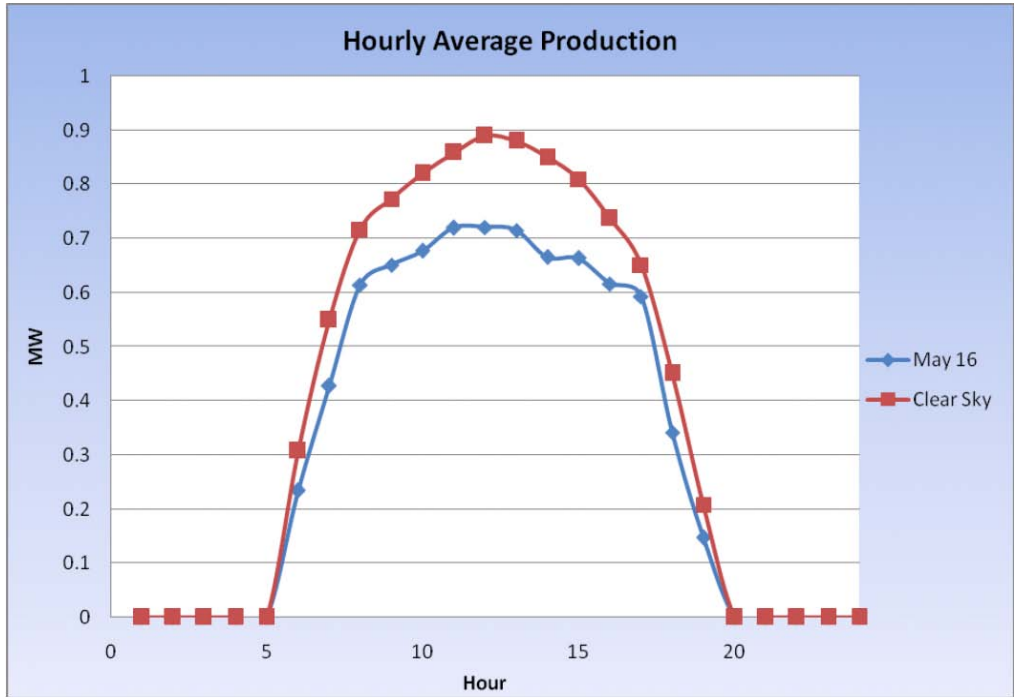

1 Minute Smoothed Production Data for a Tracking PV in the Mountain Pass/Tehachapi for May 16, 2020

Figure 14: Hourly Production Data Output from SAM Model

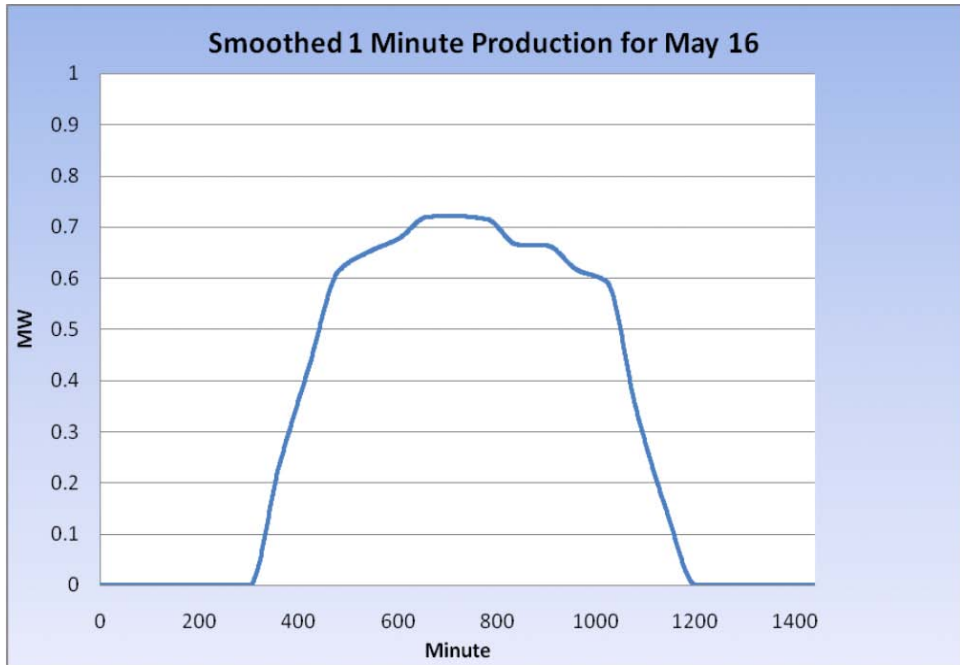

1 Minute Smoothed Production Data for a Tracking PV in the Mountain Pass/Tehachapi for May 16, 2020

Figure 15: Hourly Production Data Output from SAM Model After Spline Fit

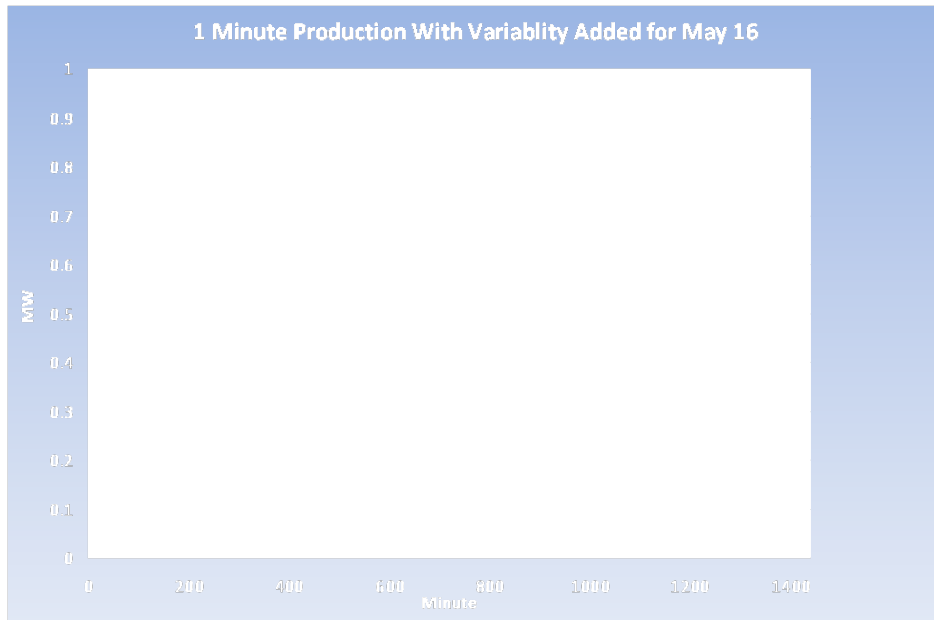

1 Minute Production Data With Historical Variability Added for a Tracking PV in the Mountain Pass/Tehachapi for May 16, 2020

Figure 16: Hourly Production Data Output from SAM Model After Variability Is Added

B-6 Analysis of Load Forecast Error

Load forecast errors were modeled based on historical data gathered by the ISO, particularly from 2006 in preparation for the first integration study. The seasonal forecasting errors were assumed to be the same for the analysis of 2012 at 20% RPS, but to have improved for 2020, as discussed in appendix B-9. The load forecast errors were characterized for two different timeframes, the hour ahead and each five-minute interval within the operating hour. For each timeframe, the forecasted error was determined by taking the difference between the forecasted demand for that timeframe and the actual average demand for the corresponding period. The maximum, minimum, average, and standard deviation were calculated on the forecast errors for each timeframe. The probabilities of forecast error magnitudes were then calculated by comparing the number of occurrences in error magnitudes to the total number of occurrences. Finally, four probability density functions were approximated using a truncated normal distribution that is defined by using the mean and standard deviation for the forecast errors for each season.

The truncated normal distribution is very similar to a normal distribution but differs in that its extremities are bounded or truncated. The truncated normal distribution is more practical for load

forecasting data because it is not expected that the forecasting error would exceed certain limits. The formula for the truncated normal distribution used in this study is given below:

$$PDF_{TND}(\varepsilon) = \begin{cases} 0, & -\infty \leq \varepsilon < \varepsilon_{\min} \\ \frac{PDF_N(\varepsilon)}{\int_{\varepsilon_{\min}}^{\varepsilon_{\max}} PDF_N(\varepsilon)d\varepsilon}, & \varepsilon_{\min} \leq \varepsilon \leq \varepsilon_{\max} \\ 0, & \varepsilon_{\max} \leq \varepsilon \leq +\infty \end{cases}$$

$$PDF_N(\varepsilon) = \frac{1}{\sqrt{2\pi\sigma^2}} e^{-\frac{1}{2}\left(\frac{\varepsilon-\varepsilon_0}{\sigma}\right)^2}, \quad -\infty \leq \varepsilon \leq +\infty$$

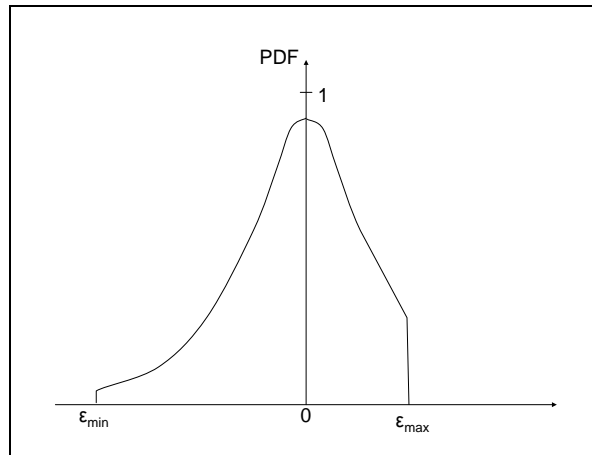

Figure 17: Unbiased Truncated Normal Distribution

In addition, the autocorrelation coefficient (R) was calculated to determine if the forecast errors are time dependent, i.e. whether the forecast load is typically under-forecast or over-forecast for certain time periods. The autocorrelation depends on the number of observations, the standard deviation of the observations, the sample mean and the current and next observation:

$$R = \frac{1}{(n-1)\sigma^2} \sum_{i=1}^{n-1} (X_i - \mu)(X_{i+1} - \mu)$$

Where:

- n is the number of occurrences,
- X is the value of the error at that time,
- μ is the average value of the error,
- σ is the standard deviation of the error.

R has values between -1 and 1. A value of 1 indicates that the next value has a very strong positive dependence on the previous value, while a value of -1 indicates that the next value has a strong negative dependence on the previous value. An autocorrelation value of zero indicates that the current value gives no indication of what the next value will be. The calculated autocorrelation values are shown in Table 4.

Hour Ahead Forecast

The hour-ahead load forecast error is simply the difference between the hour ahead forecast and the average hourly actual demand for a particular operating hour. For 2006, the hour ahead load forecast was found to have a mean absolute error (MAE) of approximately 2% of actual load.

$$MAE = \frac{1}{N} \sum \frac{Forecast - Actual}{Actual} \times 100$$

The raw forecast error data was filtered through a two-step process to remove bad data points: (1) errors in excess of 50% of actual load were removed, and (2) errors greater than 3 standard deviations from the mean were removed.

Table 4 summarizes the minimum, maximum, average, standard deviation and autocorrelation of the hour ahead load forecast errors for the different seasons.

Table 4: Summary of 2006 hour-ahead load forecast error (Actual Load – Forecast Load)

Season	Average (MW)	Min (MW)	Max (MW)	Standard Deviation (MW)	Autocorrelation
Winter	-35.2	-3,849	1,519	652	0.69
Spring	-24.1	-2,101	1,931	601	0.73
Summer	-130.4	-3,771	2,446	900	0.89
Fall	-69.2	-2,628	2,081	687	0.83

To evaluate the shape of the errors, Figure 2 shows the comparison of the theoretical load error distribution (red line) to actual load error distributions (blue bars) for the 2006 spring months. As shown, the forecasting errors correspond to a truncated normal distribution function.

Five-Minute Load Forecast (Real Time Forecast)

The five-minute load forecast consists of a block of power for that 5-minute interval and historically was run about 10-minutes before the operating interval. Variation within that five-minute interval is made up with regulation. The mean absolute error of the five-minute load forecast is 0.29%.

Table 5 below shows the minimum, maximum, average, standard deviation and autocorrelation of the five-minute forecasting error.

Figure 19 shows the five-minute load forecast error for one month of data (mid-March through mid-April) is less than 100 MW for almost 85% of the time. The shape also corresponds to a truncated normal distribution.

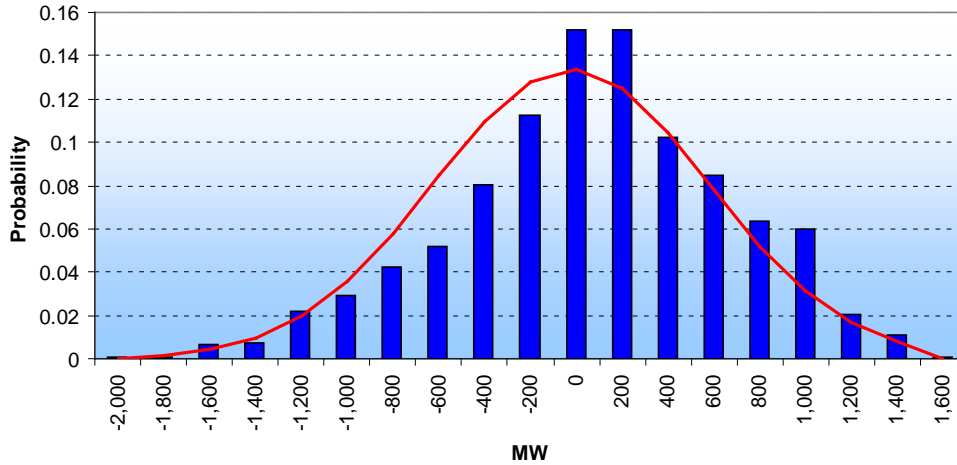

Figure 18: Hour-Ahead Load Forecasting Error, Spring 2006

Table 5: Summary of five-minute load forecast error, Spring 2006

Average (MW)	Min (MW)	Max (MW)	Standard Deviation (MW)	Autocorrelation
1.15	-349	349	98	0.61

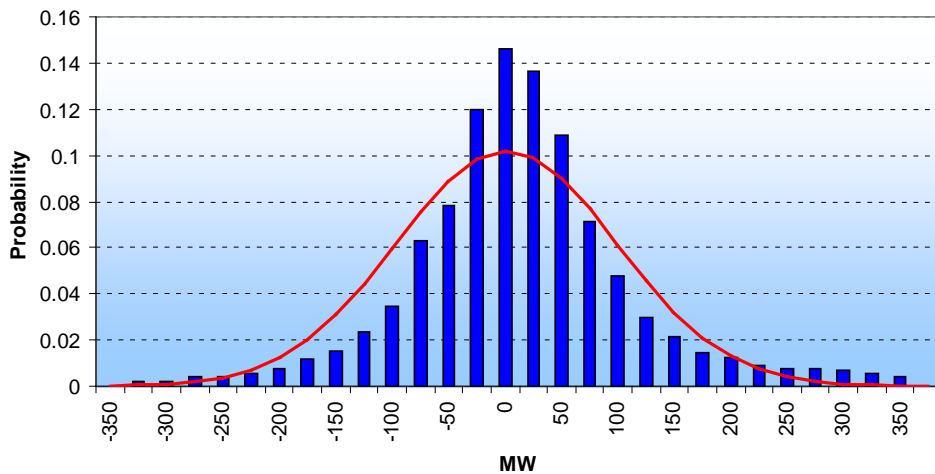

Figure 19: Comparison of five-minute load forecast error and theoretical error distribution, mid-May to mid-April, 2006

B-7 Analysis of Wind Forecast Error

Similarly to the analysis of load forecast errors, the analysis of wind forecast errors developed for the 2007 Report was largely carried over in the 2010 20% RPS and 33% RPS studies. The exception is the improvement in wind forecast errors for the 2020 timeframe, as shown in Appendix B-9.

For the 2007 Report, the two-hour ahead wind forecast error was analyzed in order to give an estimate of the types of errors one could expect in the 2012 time frame. The wind forecast error is defined as a percentage of total installed wind park capacity and is calculated by taking the difference between the actual and forecast production for a given hour divided by the plants capacity. The statistics for the forecast error were also calculated for each time frame and are summarized in Table 6. In addition to the seasonal statistics the mean absolute percent error (MAPE) was also calculated to be 5.94% for the entire time period.

$$\varepsilon = \frac{Actual - Forecast}{Capacity}$$

$$MAPE = \frac{1}{N} \sum_{i=1}^{i=N} |\varepsilon_i|$$

Additionally, the autocorrelation error was calculated to determine if the forecast errors are time dependent, (i.e. whether the forecast wind generation is typically under-forecast or over-forecast for certain time periods).

Table 6: Summary of two hour-ahead wind forecast error in 2006

	Average	Minimum	Maximum	Standard Deviation	Autocorrelation
Winter	0.00	-0.36	0.31	0.07	0.61
Spring	0.00	-0.43	0.31	0.09	0.71
Summer	0.00	-0.32	0.31	0.08	0.65
Fall	0.00	-0.32	0.40	0.08	0.59

Finally, the statistical distribution of the forecast error was analyzed and compared to a truncated normal distribution as shown in Figure 20. The truncated normal distribution is more practical for real datasets such as wind forecast errors since it is not expected that the wind forecast errors would exceed the wind plant capacity. The formula for the truncated normal distribution is the same formula as presented for load forecast error in Appendix B-6. Appendix C-1 explains the rules for calculating the truncation as a function of the forecast error random draw and the wind production as a percentage of total wind capacity in each interval.

A persistence model is used for simulating the real-time wind forecast. This model is explained in Appendix C-1, in the subsection on simulation of real-time scheduling.

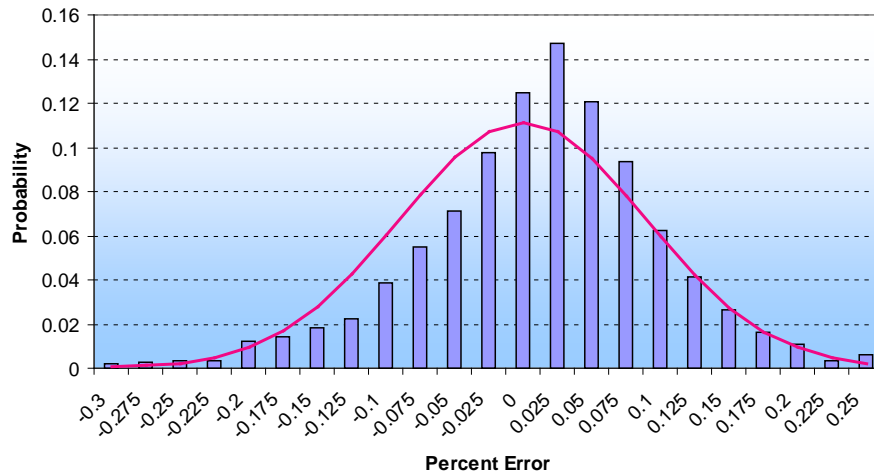

Figure 20: Two-hour-ahead wind forecasting error, Spring 2006

Consideration of geographical diversity

Due to a lack of forecast data in many of the CREZs where future wind may be located, the analysis of forecast error does not consider the effect of geographical diversity. That is, the model does not consider that some locations will have different forecast errors than others, nor the correlation of errors between those locations. Instead, the full wind production within California is assumed to experience the same forecast error. However, as noted in Appendix B-4, the wind resource production does vary by location, and hence the aggregate wind production profile does capture the effect of geographical diversity on variability.

B-8 Analysis of Solar Generation Forecast Error

This appendix explains the calculation of the statistical characteristics of the hour-ahead and real time solar generation forecast errors used in the simulation of load following and regulation requirements. These models are complex and depend on various factors including the extraterrestrial solar radiation annual and daily patterns, hour-to-hour clearness index, dynamic patterns of the cloud systems, types of solar generators (PV, concentrated thermal, etc.), geographical location and spatial distribution of solar power plants, and other factors. Due to the lack of solar forecasting data, an effort was made to build an adequate solar generation model which is described in the following sections.

NOTE: THE NOTATION IN THIS SECTION, P , (FOR SOLAR PRODUCTION) IS INTERCHANGABLE WITH G^S (FOR SOLAR GENERATION) IN APP. C-1. NOTATION WILL BE STANDARDIZED IN THE NEXT DRAFT.

Upper and Lower Limits for the Solar Generation Forecast Error

Unlike wind generation, which is only limited by its available capacity and zero (static limits), solar generation is limited by the extraterrestrial solar irradiance level, changing over a day. It also depends on the clearness index (CI), which can be defined as the actual solar irradiance divided by the “ideal” solar irradiance. The ideal irradiance can be observed when the sky is clear. The maximum possible generation can be achieved at $CI = 1$, and this maximum value $P_{\max}(t)$ also changes over the day following a similar mostly deterministic pattern (note that there is also a time-of-the-year variable component in this process). Variances of the generation under these conditions can be only caused by diffused solar irradiance and ambient temperature variations. Assuming that these variances are also included in $P_{\max}(t)$, the actual solar generation $P_a(t)$ during the day time can be described as a function of time, which is always less or equal to the maximum capacity, i.e.:

$$P_a(t) \leq P_{\max}(t) \quad (1)$$

where $P_{\max}(t)$ is the maximum solar generation capacity, and is a function of time.

The solar forecast $f(t)$ should also be limited by $P_{\max}(t)$ as follows:

$$P_{\min}(t) \leq f(t) = P_a(t) - \varepsilon(t) \leq P_{\max}(t) \quad (2)$$

where the minimum solar capacity $P_{\min}(t)$ could be assumed to be zero, and $\varepsilon(t)$ is solar forecast error.

During the night time,

$$f(t) = P_a(t) = \varepsilon(t) = 0 \quad (3)$$

From (2), dynamic limits for the solar forecast error are obtained:

$$\varepsilon_{\min}(t) = P_a(t) - P_{\max}(t) \leq \varepsilon(t) \leq \varepsilon_{\max}(t) = P_a(t) \quad (4)$$

where $P_a(t) - P_{\max}(t)$ may be negative or zero.

Standard Deviation of the Forecast Error Evaluated Using CI

Different solar generation patterns need to be considered for the solar forecast errors during the day and night time. The night time solar forecast are zero because there is no solar irradiance, thus the solar generation is zero. The sunrise and sunset time are different in different seasons at different geographical locations, as well as the daily patterns of the clearness index CI .

Depending on the time of a day and weather conditions, the solar forecast errors can show different patterns, such as: (a) the forecast error is zero, $\varepsilon = 0$, at night time; (b) the forecast error is small or close to 0, $\varepsilon \rightarrow 0$, on sunny days, that is when $CI \rightarrow 1$; (c) the forecast error is limited or close to zero under heavily cloud conditions, that is when $CI \rightarrow 0$, and (d) the forecast error varies in a wide range for the intermediate values of CI , as shown by (4).

Thus, the standard distribution of the solar forecast errors can be described as a function of a parameter CI , $0 \leq std_{\min} \leq std(\varepsilon) \leq std_{\max}$. Figure 5 shows a possible distribution of standard deviation of solar forecast errors depending on the clearness index.

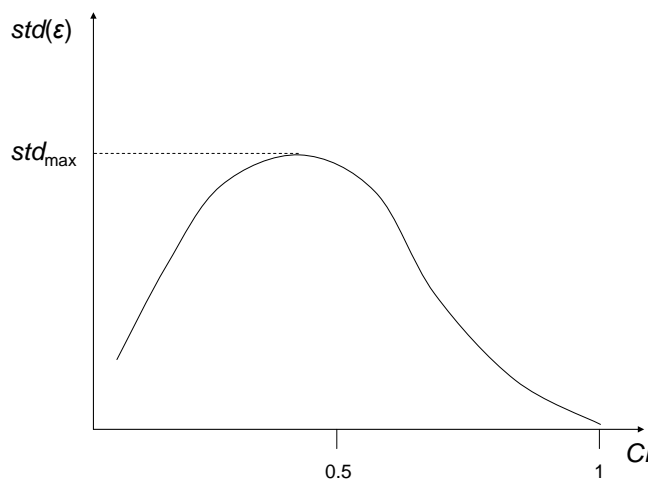

Figure 21: Distribution of the standard deviation of solar forecast error depending on the clearness index

Truncated Normal Distribution

The assumption used in the model is that the hour-ahead solar generation forecast error distribution is an unbiased Truncated Normal Distribution (TND) shown in Figure 21. The Probability Density Function (PDF) of the doubly truncated normal distribution is expressed as follows:

For a random variable x , the probability density function of the normal distribution is

$$PDF_N(x) = \frac{1}{\sigma\sqrt{2\pi}} \exp\left(-\frac{(x-\mu)^2}{2\sigma^2}\right) \quad (5)$$

For a mean of $\mu = 0$ and a standard deviation of $\sigma = 1$, this formula simplifies to

$$\phi(x) = \frac{1}{\sqrt{2\pi}} \exp\left(-\frac{x^2}{2}\right) \quad (6)$$

which is known as the standard normal distribution.

Suppose the solar forecast error $\varepsilon \sim N(\mu, \sigma^2)$ has a normal distribution and lies within the interval $\varepsilon \in [\varepsilon_{\min}, \varepsilon_{\max}]$, $-\infty \leq \varepsilon_{\min} < \varepsilon_{\max} \leq \infty$. Then ε has a truncation normal distribution with a probability density function

$$PDF_{TND}(\varepsilon; \mu, \sigma, \varepsilon_{\min}, \varepsilon_{\max}) = \frac{\frac{1}{\sigma} \phi\left(\frac{\varepsilon - \mu}{\sigma}\right)}{\Phi\left(\frac{\varepsilon_{\max} - \mu}{\sigma}\right) - \Phi\left(\frac{\varepsilon_{\min} - \mu}{\sigma}\right)} \quad (7)$$

where $\phi(\cdot)$ is the probability density function of the standard normal distribution, $\Phi(\cdot)$ its cumulative distribution function, with the understanding that if $\varepsilon_{\max} = \infty$, then $\Phi\left(\frac{\varepsilon_{\max} - \mu}{\sigma}\right) = 1$, and if $\varepsilon_{\min} = -\infty$, then $\Phi\left(\frac{\varepsilon_{\min} - \mu}{\sigma}\right) = 0$.

For the two side truncation:

$$avg(\varepsilon | \varepsilon_{\min} < \varepsilon < \varepsilon_{\max}) = \mu + \sigma \frac{\phi\left(\frac{\varepsilon_{\min} - \mu}{\sigma}\right) - \phi\left(\frac{\varepsilon_{\max} - \mu}{\sigma}\right)}{\Phi\left(\frac{\varepsilon_{\max} - \mu}{\sigma}\right) - \Phi\left(\frac{\varepsilon_{\min} - \mu}{\sigma}\right)} \quad (8)$$

$$std^2(\varepsilon | \varepsilon_{\min} < \varepsilon < \varepsilon_{\max}) = \sigma^2 \left[1 + \frac{\frac{\varepsilon_{\min} - \mu}{\sigma} \phi\left(\frac{\varepsilon_{\min} - \mu}{\sigma}\right) - \frac{\varepsilon_{\max} - \mu}{\sigma} \phi\left(\frac{\varepsilon_{\max} - \mu}{\sigma}\right)}{\Phi\left(\frac{\varepsilon_{\max} - \mu}{\sigma}\right) - \Phi\left(\frac{\varepsilon_{\min} - \mu}{\sigma}\right)} - \frac{\left(\phi\left(\frac{\varepsilon_{\min} - \mu}{\sigma}\right) - \phi\left(\frac{\varepsilon_{\max} - \mu}{\sigma}\right)\right)^2}{\left(\Phi\left(\frac{\varepsilon_{\max} - \mu}{\sigma}\right) - \Phi\left(\frac{\varepsilon_{\min} - \mu}{\sigma}\right)\right)^2} \right] \quad (9)$$

The error limits used in the TND reflects the maximum and minimum solar generation values. It is important to note that the forecast error limits ε_{\min} and ε_{\max} are actually functions of the day time and

depend on the maximum possible generation at a particular time of a day, corresponding to the clearness index value $CI = 1$. As shown in Figure 22 (a) and (b), at any particular time t of a day, the actual solar generation P_a is limited by $P_{\min} = 0$ and P_{\max} . The forecast error limits can be found as follows:

$$\begin{aligned} \varepsilon_{\min}(t) &= P_a(t) - P_{\max}(t) \\ \varepsilon_{\max}(t) &= P_a(t) \end{aligned} \tag{10}$$

Appendix C-1 explains the rules for calculating the truncation as a function of the forecast error draw and the solar production as a percentage of total wind capacity in each interval.

Asymmetries of the Forecast Error

The forecast error can be predominantly negative if the sky is covered with clouds. The typical forecast error on a cloudy day is shown in Figure 22 (a). Figure 22 (b) shows the forecast error for a typical sunny day with forecast errors that are predominantly positive.

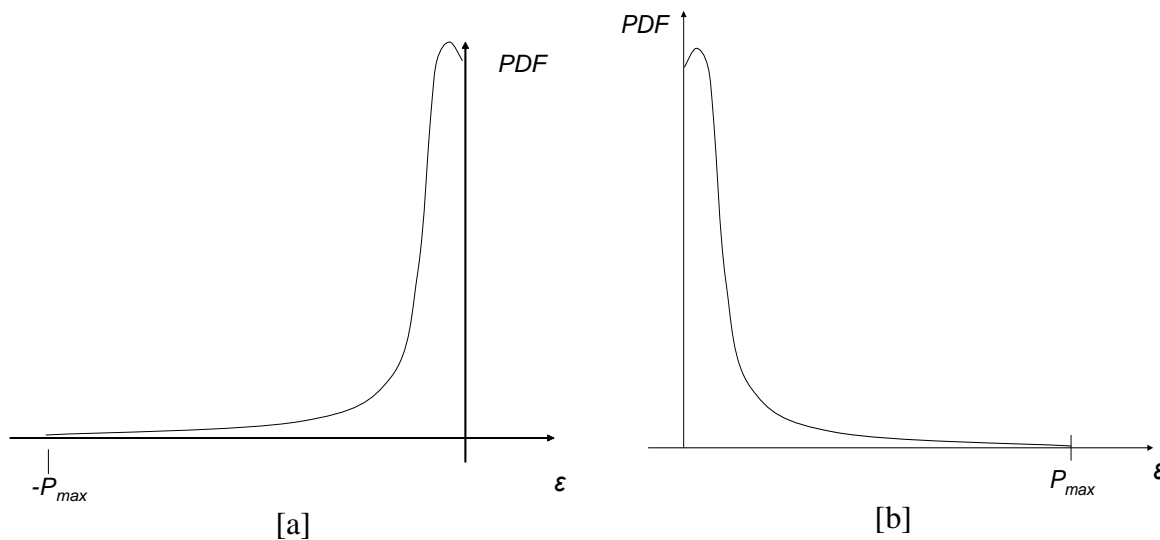

Figure 22: Distribution of solar forecast error on (a) a very cloudy day and (b) a very sunny day

Autocorrelation and Cross-correlation of the Forecast Error

Load and wind generation have strong autocorrelation between subsequent samples of their forecast errors. To some extent, this may also be the case for the solar power generation forecast error. The autocorrelation, if it is positive and significant, means that the forecast error is not changing significantly from one sample to another, and that it has certain “inertia” associated with the error’s subsequent values. To reflect this fact while simulating the solar forecast error, an autocorrelation factor is incorporated into the simulations.

Evaluation of Forecast Error Based on CI

For the analysis, two types of solar generation, i.e. solar PV and solar thermal, were used. Actual minute-to-minute solar generation data in 2005 and simulated 2020 solar generation data described in Appendix B-5 were used. Future solar generation is expected to include solar PV, distributed solar PV, solar thermal and out-of-state solar.

Due to the lack of global solar radiation and extraterrestrial solar irradiance data, solar generation profiles for actual solar generation and “ideal” solar generation (clear sky) are used to calculate the clearness index:

$$CI = \frac{\text{Actual Solar Generation}}{\text{Ideal Solar Generation}} \quad (11)$$

Appendix B-5 describes how the actual solar generation profile and ideal solar generation profile were created for each type of future solar generation. As noted, the solar generation profiles for 2005 and 2020 were on a 1-minute resolution.

The clearness index is calculated as:

$$CI(t) = \frac{P_a(t)}{P_{max}(t)}, t = 1, \dots, n \quad (12)$$

where $P_a(t)$ is the actual solar generation at the t -th minute, and $P_{max}(t)$ is the ideal solar generation at the t -th minute. $CI(t)$ is used in the real-time and hour-ahead solar generation forecast error models. The values of clearness index are in the range of [0, 1].

Because the solar forecast error modeling is a function of the random draws from the clearness index, the remainder of this process is presented in Appendix C-1 in the hour-ahead scheduling model.

Consideration of technological and geographical diversity

The analysis of forecast errors captures the effect of technological diversity on solar forecast errors because a specific model was developed to estimate forecast errors for 4 different solar technologies: solar thermal (both in and out of state), solar PV, and distributed solar. However, due to a lack of forecast data in many of the CREZs where future wind and solar may be located, the analysis of forecast error does not consider the effect of geographical diversity. That is, the model does not consider that some locations will have different forecast errors than others nor the correlation of errors between those locations.

B-9 Improvements in Forecast Errors

In each of the studies, the ISO has modeled variants on changes in forecast errors for load as well as wind and solar production. These include:

- Current forecast errors (20% RPS Study)
- Improved forecast errors (33% RPS Study)
- Zero forecast errors (20% RPS Study; 33% RPS Study)

The improved forecast error represents an estimate of the possible forecast improvement by 2020. An improvement of 10% is assumed for hour-ahead and 5-minute real-time load forecast. For the wind forecast, the assumption is that a doubling in the geographic diversity of wind generation locations (0.72 multiplier) and improve the forecast error by 20% due to better forecasting, leads to an improvement over the current error values reflected by a multiplier of 0.56.

For solar forecast error, a 50% improvement was assumed for the cloudy days.

The zero forecast error cases assume perfect foresight of load, wind and solar. The hour-ahead load, wind and solar forecast error all are set to zero. The real-time forecast error for load is also set to be zero. However, the persistence model is continually used for the wind and solar 5 minute forecast.

Table 7 summarizes the statistical parameters in the forecast error cases:

Table 7: Summary of forecast error statistics in current, improved and zero forecast error cases

Forecast Error cases for High Load												
	Forecast Error Current (Err_all_in)				Improved Forecast Error (Err1)				Zero Forecast Error (Err0)			
	Spring	Summer	Fall	Winter	Spring	Summer	Fall	Winter	Spring	Summer	Fall	Winter
Load HA (MW)	923.45	1278.45	927.90	969.76	831.11	1150.61	835.11	872.79	0	0	0	0
Load RT (MW)	140	140	140	140	126	126	126	126	0	0	0	0
Wind HA (In Percentage)	0.0899	0.0796	0.0792	0.0723	0.0503	0.0446	0.0444	0.0405	0	0	0	0
Wind RT	persistence (t-8)	persistence (t-8)	persistence (t-8)	persistence (t-8)	persistence (t-8)	persistence (t-8)	persistence (t-8)	persistence (t-8)	persistence (t-8)	persistence (t-8)	persistence (t-8)	persistence (t-8)
	Forecast Error Current (Err_all_in)				Improved Forecast Error (Err1)				Zero Forecast Error (Err0)			
CI	0<=CI<=0.2 0	0.2<CI<=0.5	0.5<CI<=0.8	0.8<CI<=1	0<=CI<=0.2 0	0.2<CI<=0.5 5	0.5<CI<=0.8 8	0.8<CI<=1	0<=CI<=0.2 20	0.2<CI<=0.5	0.5<CI<=0.8	0.8<CI<=1
Solar HA (In percentage)	0.05	0.2	0.15	0.05	0.05	0.1	0.075	0.05	0	0	0	0
Solar RT	persistence (t-8)	persistence (t-8)	persistence (t-8)	persistence (t-8)	persistence (t-8)	persistence (t-8)	persistence (t-8)	persistence (t-8)	persistence (t-8)	persistence (t-8)	persistence (t-8)	persistence (t-8)

SECTION C

This section describes the statistical model used to estimate operational requirements for regulation, load following and operational ramps in the presence of additional variable energy resources. The core elements of the methodology were first implemented in the ISO's 2007 Report,¹ and then extended to include solar variability and forecast errors for application in the ISO's August 2010 study and subsequent studies. The methodology results have also been reported more extensively in the more recent studies. Where possible, there is some continuity in the presentation and notation of the 2007 Report appendices.

Note that throughout this appendix, 2006 is used as the base-year in the mathematical notation, because it served as the base-year for the 20% RPS Study. However, 2005 is the base-year for the solar production data. In later versions of this appendix, a more generic index will likely be used.

C-1 Methodology for Statistical Analysis of Operational Requirements

There are several statistical methodologies that have been used in renewable integration studies to determine hourly and sub-hourly operational requirements and, by inference, integration costs.² This study uses a stochastic process developed by the ISO and Pacific Northwest National Laboratory (PNNL) that employs Monte Carlo simulation, which uses random sampling over multiple trials or iterations to estimate the statistical characteristics of a mathematical system. The simulation is designed to model aspects of the daily sequence of ISO operations and markets in detail, from hour-ahead to real-time dispatch. The objective is to measure changes in operations at the aggregate power system level, rather than at any particular location in the system. The model provides realistic representations of the interaction of load, wind and solar forecast errors and variability in those time frames and evaluates their possible impact on operational requirements through a very large number of iterations. The shape of the distribution of forecast errors was described and validated in Appendices B-6 to B-8. The model also incorporates some representation of system ramps between hours to improve accuracy. However, there is no explicit representation of any generation other than wind and solar, although the model could be extended to include a statistical model of deviations of conventional generation from dispatch instructions (uninstructed deviations).

Generally, the modeling makes certain assumptions about the timing and availability of wind and solar forecasts, as explained in the text. Notably, the modeling assumes that the ISO has an hour-ahead

¹ See also Makarov, et al., "Operational Impacts of Wind Generation on California Power Systems," *IEEE Transactions on Power Systems*, Vol. 24, No. 2, (May 2009).

² Earlier studies of California operational requirements using alternative statistical methods include the California Energy Commission, "Intermittency Analysis Project" (2007), CEC-500-2007-081 at <http://www.energy.ca.gov/2007publications/CEC-500-2007-081/CEC-500-2007-081.PDF> (hereafter "CEC IAP Study"). The ISO's 2007 Report adopted a different statistical method, which is developed further in the present study.

forecast of all variable energy resources in its BAA. Currently it only gets forecasts for resources in the Participating Intermittent Resource Program (PIRP).

Also, impacts of wind and solar generation on the interconnection frequency are neglected.

Determination of In-State vs. Out-of-State Resources

The ISO will assume for purposes of the statistical model, that a portion of the out-of-state renewable resources are non-variable production (i.e., firmed and shaped) so that they do not contribute to the requirement for in-state regulation and load-following. For example, in the 33% RPS studies, the ISO has assumed that 70% of out of state resources should be modeled in this way and the remaining 30% as relying on ISO integration in the hour, and hence included in the statistical modeling. The ISO believes that this is a reasonably conservative starting point assumption that could be refined based on actual practice. The ISO will continue, with input from stakeholders, to estimate the various mixes and amounts of solar and wind that will be imported as well as the impacts of different potential import mechanisms. Such estimates should consider four potential conditions:

- 1) Imported resources are fully firmed and shaped and, as a result, such imports do not create a within-the-hour flexibility burden on the ISO.
- 2) Imported resources that are contingent firmed and shaped, in which case the sending BAA may make intra-hour scheduled adjustments to the deliveries based on the changes in the condition in host BAA and ability of the host BAA to balance these resources. Under these circumstances there will be some variability burdens the ISO will still have to manage.
- 3) Renewable resources that are not delivered at all but LSEs receive renewable energy credits. In this case the resource variability does not create an operational burden on the ISO BAA.
- 4) Imported resources are dynamically transferred into the ISO in which case the ISO will be responsible for the variability and uncertainty.

As the expected quantity of these different scenarios can be determined, the ISO can further modify the statistical analysis to consider the import of renewable resources.

Actual Load and Wind/Solar Generation in the Target Year

The model begins from the “actual” 1-minute data on load and wind and solar generation for the base-year and the target year. The process for developing this data was described in Appendices B-1, B-2, B-4 and B-5. For purposes of this appendix, the following notation is used:

L_a^{2006+i}	actual load in the target year,
$G_a^{w,2006+i}$	actual wind generation in the target year,
$G_a^{s,2006+i}$	actual solar generation in the target year,

Where

a	index for “actual” 1-minute data,
w	superscript indicating wind
s	superscript indicating solar
L	load
G	generation

As described in the next sections, the actual data becomes the basis for the hourly average and 5-minute average data that is used in the statistical model.

Hour-Ahead Schedule for Load and Wind/Solar Generation

This section explains how the load and renewable production data is aggregated from the 1-minute data set to create averaged hour-ahead schedules for each hour of the year (the subsequent section explains how the 5-minute dispatch schedules are developed). This section then describes the process for generating random errors based on the hour-ahead forecast errors. The presentation of the equations for the random process for calculating load, and wind/solar generation deviations based on forecast errors, which are combined for each hour being modeled into one deviation from the sum of the hourly average actual data, is slightly repetitive, but there are differences in the process of determining the random errors and in the shape of the forecast error distributions that require separate explanation.

Hour Ahead Load Schedule Model

As noted in Appendix A, the ISO hour-ahead schedules for load and energy consist of one-hour (1hr) block energy schedules that include 20 minute ramps between the hours. This is shown for hour-ahead load schedules in Figure 23. This figure could be extended to the hour-ahead schedules for wind and solar generation discussed next.

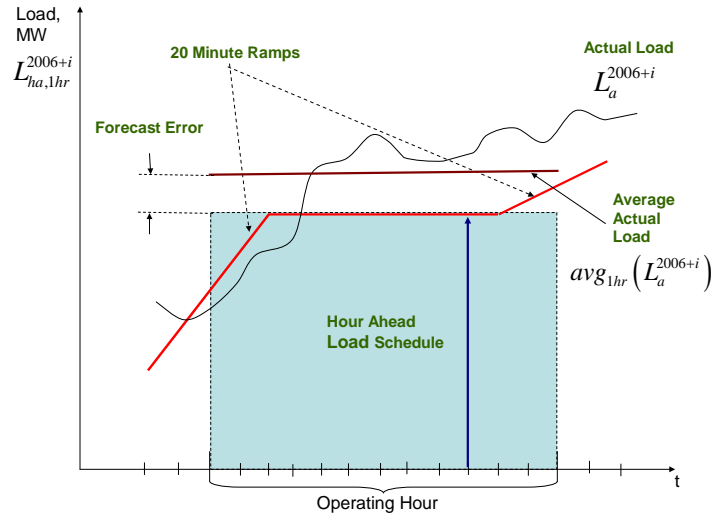

Figure 23: CAISO Simulated Hour Ahead Load Schedule (Red Line)

The “actual” load schedule for the hour, $L_{a,1hr}^{2006+i}$, prior to consideration of randomly generated forecast errors is denoted:

$$L_{a,1hr}^{2006+i} = avg_{1hr} L_a^{2006+i} \quad (13)$$

Where:

avg average, and
 $1hr$ subscript denoting the interval length of one (1) hour.

This initial schedule is thus simply the average load for the hour based on the actual 1-minute load data. Next, the randomly generated hour-ahead load schedule, $L_{ha,1hr}^{2006+i}$, is simulated based on the projected actual load and the expected load forecast error:

$$L_{ha,1hr}^{2006+i} = \mathfrak{R}_{20} \{ L_{a,1hr}^{2006+i} - \varepsilon_{L,ha} \} \quad (14)$$

Where:

\mathfrak{R}_{20} is an operator that adds 20 minute ramps to the block energy load schedule.

Note that the 20-minute ramps are added to each randomly generated hour-ahead schedule to connect it to the next randomly generated hour-ahead schedule in the sequence.

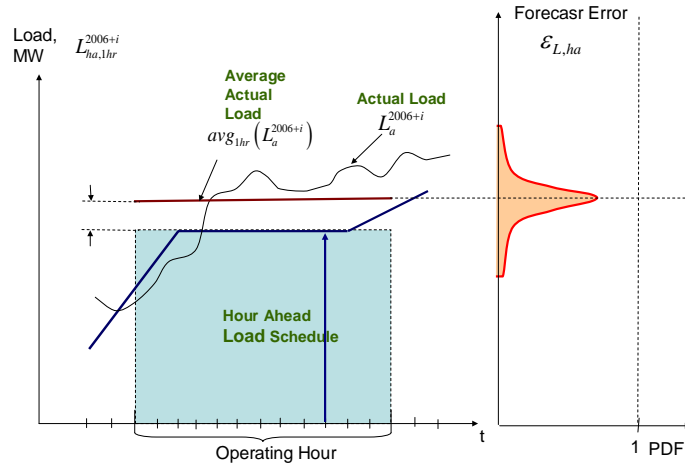

Figure 24: Probability Density Function (PDF) of the Load Forecast Function (Red Line)

The error time-series is simulated using a random number generator based on the statistical characteristics of the load forecast error derived from the year indicated in each study. As discussed in Appendix A-7, the probability distribution for the load forecast error is the doubly truncated normal distribution shown in Figure 17. The truncated distribution helps to eliminate “tails” of the normal distribution which would correspond to some unrealistically significant forecast errors. Based on these specified values, a random number generator is used to generate values of $\varepsilon_{L,ha}$. For each operating hour, the random values of $\varepsilon_{L,ha}$ will be substituted into (14) to produce the simulated hour-ahead load schedule. As noted, it is assumed that the load error distribution is *unbiased* for $PDF_N(\varepsilon)$, that is $\varepsilon_0 = 0$, and $\varepsilon_{L,ha}^{\min}$, $\varepsilon_{L,ha}^{\max}$ correspond to the minimum and maximum forecast errors specified for this study. These values are set to the following values ($L_{ha,1hr}^{2006+i}$ is the target year hour ahead scheduled load, and L_a^{2006+i} is the actual load at the same hour):

$$\begin{aligned}
 L_{ha,1hr}^{2006+i} &= \Re \left\{ avg_{1hr} L_a^{2006+i} - \varepsilon_{L,ha} \right\}, \varepsilon_{L,ha}^{\min} \leq \varepsilon_{L,ha} \leq \varepsilon_{L,ha}^{\max} \\
 \varepsilon_{L,ha}^{\max} &= 3\sigma_{L,ha} \\
 \varepsilon_{L,ha}^{\min} &= -3\sigma_{L,ha}
 \end{aligned} \tag{15}$$

Hour-Ahead Wind Generation Schedule Model

The wind generation component of the hour-ahead schedule is developed in a largely similar fashion to the load component, with the exception that the error quantity (MW) is calculated as the randomly generated error (as a percentage) multiplied by the capacity of the wind generators.

The “actual” hourly wind schedule, $G_{a,1hr}^{w,2006+i}$, prior to consideration of randomly generated forecast errors is denoted:

$$G_{a,1hr}^{w,2006+i} = avg_{1hr} G_a^{w,2006+i} \quad (16)$$

The notation has been defined above. This initial hourly schedule is thus the average wind generation for the hour based on the actual 1-minute wind data. Next, the randomly generated hour-ahead wind generation forecast schedule, $G_{ha,1hr}^{w,2006+i}$, is simulated based on the actual hourly wind schedule and the expected hour-ahead wind forecast error:

$$G_{ha,1hr}^{w,2006+i} = \mathfrak{R}_{20} \left\{ G_{a,1hr}^{w,2006+i} - \varepsilon_{w,ha} \cdot CAP^{w,2006+i} \right\} \quad (17)$$

As with the load schedules, operator $\mathfrak{R}_{20} \{ \dots \}$ adds 20-minute ramps between the hours; $\varepsilon_{w,ha}$ is the simulated hour-ahead wind generation forecast error. The wind generation forecast error in MW is expressed in percentage of the installed capacity of the wind generators, $CAP^{w,2006+i}$. In the extension of the model to multiple locations, each with a different forecast error, the equation would require a location index on each term.

The truncated normal distribution is assumed to have the following characteristics. Parameters $\varepsilon_{w,ha}^{\min}$, $\varepsilon_{w,ha}^{\max}$ correspond to the minimum and maximum total ISO wind generation forecast errors specified for the distribution. These values are set to plus/minus 3 standard deviations of the hour-ahead wind generation forecast error, $\sigma_{w,ha}$. The standard deviation and autocorrelation are set to the seasonal values provided in Appendix A-7.

The truncation process is based on the following rules:

$$G_{ha,1hr}^{w,2006+i} = G_{a,1hr}^{w,2006+i} - \varepsilon_{w,ha} \cdot CAP^{w,2006+i}, \text{ where } \varepsilon_{w,ha}^{\min} \leq \varepsilon_{w,ha} \leq \varepsilon_{w,ha}^{\max}. \quad (18)$$

$\varepsilon_{w,ha}^{\min}$ and $\varepsilon_{w,ha}^{\max}$ can be determined by the following method:

$$\varepsilon_{w,ha}^{\min} = \begin{cases} 3\sigma_{w,ha}, & \text{if } Index_{\min} < CAP^{w,2006+i} \\ G_{a,1hr}^{w,2006+i}, & \text{if } Index_{\min} \geq CAP^{w,2006+i} \end{cases} \quad (19)$$

$$\varepsilon_{w,ha}^{\max} = \begin{cases} 3\sigma_{w,ha}, & \text{if } Index_{\max} > 0 \\ G_{a,1hr}^{w,2006+i}, & \text{if } Index_{\max} \leq 0 \end{cases} \quad (21)$$

where $Index_{\min} = G_{a,1hr}^{w,2006+i} + 3\sigma_{w,ha} \cdot CAP^{w,2006+i}$ and $Index_{\max} = G_{a,1hr}^{w,2006+i} - 3\sigma_{w,ha} \cdot CAP^{w,2006+i}$.

Hence, the forecast error is the higher of the third standard deviation of the forecast errors (in MW) or the resource's capacity (MW).

Hour-ahead Solar Generation Schedule Model

The solar generation component of the hour-ahead schedule is developed in a largely similar fashion to the wind and load components, with the exception that the error quantity is calculated using the average clearness index to determine the standard deviation of the randomly generated forecast errors. **Note that the notation in this section, G^s , is equivalent to the notation P in Appendix B-8.**

The “actual” hourly solar schedule, $G_{a,1hr}^{s,2006+i}$, prior to consideration of randomly generated forecast errors is denoted:

$$G_{a,1hr}^{s,2006+i} = avg_{1hr} G_a^{s,2006+i} \quad (22)$$

The notation has been defined above. This initial hourly schedule is thus the average solar generation for the hour based on the actual 1-minute solar data. Next, the randomly generated hour-ahead solar generation forecast schedule, $G_{ha,1hr}^{s,2006+i}$, is simulated based on the actual hourly solar schedule and the expected hour-ahead solar forecast error. This process begins with random draws of the hourly average clearness index.

The hourly average clearness index is calculated as follows:

$$CI(h) = \frac{\overline{G}_a^s(h)}{\overline{G}_{max}^s(h)} \quad (23)$$

where $\overline{G}_a^s(h)$ is the average actual solar generation during the h -th hour, and $\overline{G}_{max}^s(h)$ is the average ideal solar generation for the h -th hour.

The following procedure was applied to produce the hour-ahead solar forecast errors:

Step (1): Calculate the hourly average clearness index using (23).

Step (2): Assign a level number (1, 2, 3, or 4) and standard deviation value to each hourly average clearness index value based on Table 8.

Step (3): Generate random number sequences based on the standard deviation for different clearness index levels (using Table 8). The truncated normal distribution is applied to the random number sequences.

Step (4): Use the generated random numbers as hour-ahead forecast errors.

Because of the lack of information about the “ideal” solar generation in 2005, the clearness index, calculated based on 2020 solar generation profiles, is applied to hour-ahead solar forecast errors for both 2005 and 2020.

The clearness index is divided into four levels. For different levels of clearness index, different standard deviations are applied to produce solar forecast errors. Table 8 shows the standard deviations of solar forecast errors corresponding to different clearness index levels. The percentage number of total solar

generation capacity is used to quantify standard deviations of solar forecast errors. For example, the 5% standard deviation for the clearness index level in the range of (0, 0.5] is 5% of the capacity of the solar generation case.

Table 8: Standard deviations of solar forecast errors based on clearness index levels

Clearness Index (CI)	Std. Deviation (σ_{HA})
$0 < CI \leq 0.5$	5%
$0.2 < CI \leq 0.5$	20%
$0.5 < CI \leq 0.8$	15%
$0.8 < CI \leq 1.0$	5%

The hour-ahead solar forecast error model was applied to each solar generation profile, i.e. solar PV, distributed solar PV, solar thermal, and out-of-state solar. Finally, the overall hour-ahead solar generation forecast profile was calculated by accumulating all the hour-ahead solar forecast of different solar profiles.

Real-Time Five-minute Schedule for Load and Wind/Solar Generation

This section explains how the load and renewable production data is first aggregated from the 1-minute data set to create averaged 5-minute dispatch schedules. This section then describes the process for generating (a) random errors based on the 5-minute ahead forecast errors for load and (b) persistence forecasts for wind and solar production in the 5-10 minute time-frames. The resulting 5-minute schedule deviations are then used to measure load-following requirements (based on the MW difference between the hour-ahead schedules and the 5-minute schedules) and regulation requirements (based on the MW difference between the 5-minute schedules and the actual one-minute data).

Real Time Load Forecast

The Real Time load forecast is the average five-minute load forecast, which includes five-minute ramps between the intervals. Figure 25 provides a representation of this process.

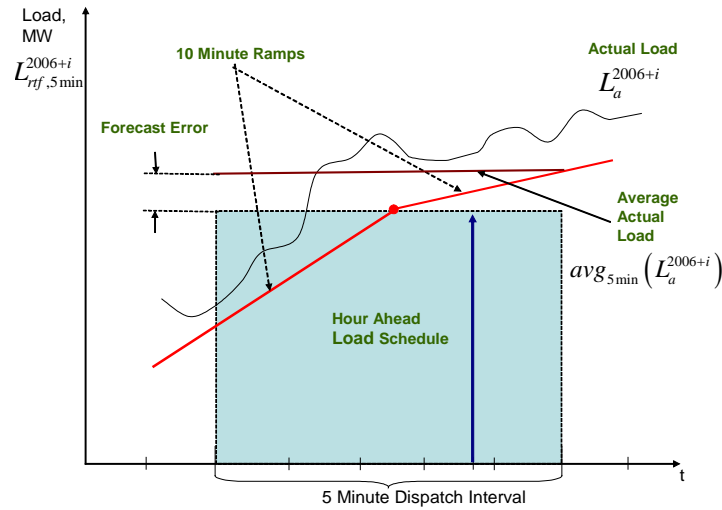

Figure 25: CAISO Simulated Real Time Load Forecast (Red Line)

The “actual” 5-minute load schedule for the hour, $L_{a,5min}^{2006+i}$, prior to consideration of randomly generated forecast errors is denoted:

$$L_{a,5min}^{2006+i} = avg_{5min} L_a^{2006+i} \quad (24)$$

Where:

$5\ min$ subscript denoting the interval length of 5 minutes.

The random 5-minute forecast schedule can then be calculated based on the load forecast error using the following approach.

The real time load forecast $L_{rf,5min}^{2006+i}$ can be simulated based on the projected actual load and the expected load forecast error $\varepsilon_{L,rf}$:

$$L_{rf,5min}^{2006+i} = \mathfrak{R}_5 \left\{ L_{a,5min}^{2006+i} - \varepsilon_{L,rf} \right\} \quad (25)$$

Where:

rf real-time forecast, and

Operator \mathfrak{R}_5 adds five-minute ramps to the block energy load schedule.

The error can be simulated using a random number generator based on the statistical characteristics of the real time load forecast error (derived from the year 2006/2007 data for the 20% RPS study and with the forecast improvements for 2020 shown in Appendix B-9). Again, the probability distribution for the

real time load forecast error is an unbiased doubly truncated normal distribution. The values of $\varepsilon_{L,rf}^{\min}$ and $\varepsilon_{L,rf}^{\max}$ are set to plus/minus $3\sigma_{L,rf}$. The standard deviation of the real-time load forecast error is $\sigma_{L,rf}$. Based on these specified values, the random number generator is used to generate values of $\varepsilon_{L,rf}$. For each operating hour, the random values of $\varepsilon_{L,rf}$ will be substituted into (25) to produce the simulated real time load forecast.

$$\begin{aligned} L_{rf,5\min}^{2006+i} &= \Re \left\{ \text{avg}_{5\min} L_a^{2006+i} - \varepsilon_{L,rf} \right\}, \varepsilon_{L,rf}^{\min} \leq \varepsilon_{L,rf} \leq \varepsilon_{L,rf}^{\max} \\ \varepsilon_{L,rf}^{\max} &= 3\sigma_{L,rf} \\ \varepsilon_{L,rf}^{\min} &= -3\sigma_{L,rf} \end{aligned} \quad (26)$$

Real-Time Wind Generation Forecast Model

Currently, the ISO does not conduct a real-time wind generation forecast as part of the real time dispatch process, but is developing an improved persistence forecast. The statistical model thus assumes that a persistence model is used. Practically this means that for a five-minute dispatch interval $[t, t + 5]$, where t is time measured in minutes, the implicit real time wind generation forecast for the next 5 minutes, $G_{rf,5\min}^{w,2006+i}$, is assumed to be equal to the actual wind generation at the moment $t - 8$:

$$G_{rf,5\min}^{w,2006+i} [t, t + 5] = G_a^w [t - 8] \quad (27)$$

The justification for assuming a persistence model based on 8 minutes prior to the dispatch interval is that, as discussed in Appendix A, the ISO conducts its determination of the next interval real-time dispatch at $t - 7.5$ minutes, with dispatch instructions sent at $t - 5$ minutes, with the expectation that generators will begin to move no later than $t - 2.5$ minutes to reach their desired dispatch point at $t + 2.5$. Hence, it is reasonable to use the rounded value of $t - 8$ minutes as the basis for instructions sent at $t - 7.5$ minutes.

Real-time Solar Generation Forecast Model

While the persistence model is used for simulating real-time wind forecasts, for the solar forecast model, there is an obvious incremental pattern of solar generation during the morning hours just after sunrise, and a decremental pattern of solar generation during the evening hours before sunset. The solar generation could increase or decrease dramatically within a very short time interval during the sunrise or sunset hours. This pattern results in significant ramps. Using a simple persistence model for the solar power production cannot reflect this phenomenon. Thus, a new persistence model based on the clearness index was developed for the real-time solar forecast errors. The following steps were included into the forecast error model:

Step (1): Calculate the clearness index 7.5 minutes prior to the current minute:

$$CI(t - 7.5) = \frac{G_a^s(t - 7.5)}{G_{\max}^s(t - 7.5)} \quad (28)$$

Step (2): Calculate the mean value of maximum power generation for the next 5-minute interval [assume that P is equivalent notation to G]:

$$\bar{P}_{\max}(t:t+5) = \frac{\sum_{i=t}^{t+5} P_{\max}(i)}{5} \quad (29)$$

Step (3): Calculate the real-time solar generation forecast for the next 5-minute interval:

$$f_{RT}(t:t+5) = CI(t-7.5) \times \bar{P}_{\max}(t:t+5) \quad (30)$$

Step (4): Apply a 5 minute ramp on the real-time solar forecast f_{RT} .

The proposed real-time solar forecast model takes into account clearness index at $(t-7.5)$ minute and assumes that it is constant over the real time horizon. The forecasted solar generation is adjusted with respect of time varying “ideal” solar irradiance, but for the same clearness index. Therefore the incremental and decremental patterns on solar generation at sunrise and sunset hours are reflected in the proposed model. The proposed real-time solar forecast model is applied to each solar generation profile, i.e. solar PV, distributed solar PV, solar thermal, and out-of-state solar. Finally, the overall real-time solar generation forecast errors were calculated by accumulating all the real-time solar forecast errors for different solar profiles.

Definition and Measurement of Regulation and Load-Following

To ensure that regulation and load-following are appropriately distinguished, the analysis is based on short-term forecasts of the system total load and total wind and solar generation. *Regulation* is interpreted as the difference between the actual minute-by-minute ISO generation requirement and the short-term five-minute forecast/schedule. In Figure 26 it is shown illustratively as the red shaded area. The following equation, which drops the notation for the year being modeled, shows that the measured 1-minute quantities of regulation are the difference between the actual 1-minute net load (load minus wind and solar production) and the 5-minute forecast net load dispatch schedule:

$$\Delta G^r(m) = L_a(m) - G_a^w(m) - G_a^s(m) - L_{rf,5\min}(m) + G_{rf,5\min}^w(m) + G_{rf,5\min}^s(m)$$

Where

ΔG^r is the change in regulation generation,
 m is minutes.

Similarly, *load following* is defined as the difference between the hourly energy schedule including 20-minute ramps (shown as the red line) and the short-term five-minute forecast/schedule. In Figure 27 it is shown as the blue areas below the curves. The following equation, which also drops the notation for the year being modeled, shows that the measured 5-minute quantities of load-following are the difference between the 5-minute forecast of net load (load minus wind and solar production) and the hour-ahead forecast of net load:

$$\Delta G^{lf}(m) = L_{rf,5min}(m) - G_{rf,5min}^w(m) - G_{rf,5min}^s(m) - L_{ha,1hr}(m) + G_{ha,1hr}^w(m) + G_{ha,1hr}^s(m)$$

Where

ΔG^{lf} is the change in regulation generation.

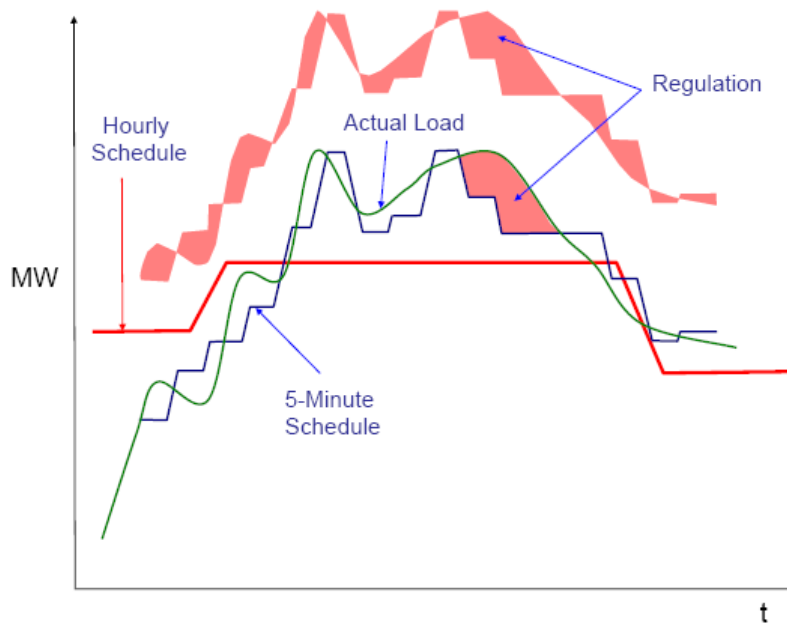

Figure 26: Depiction of the Regulation requirement, shown as the red shaded area

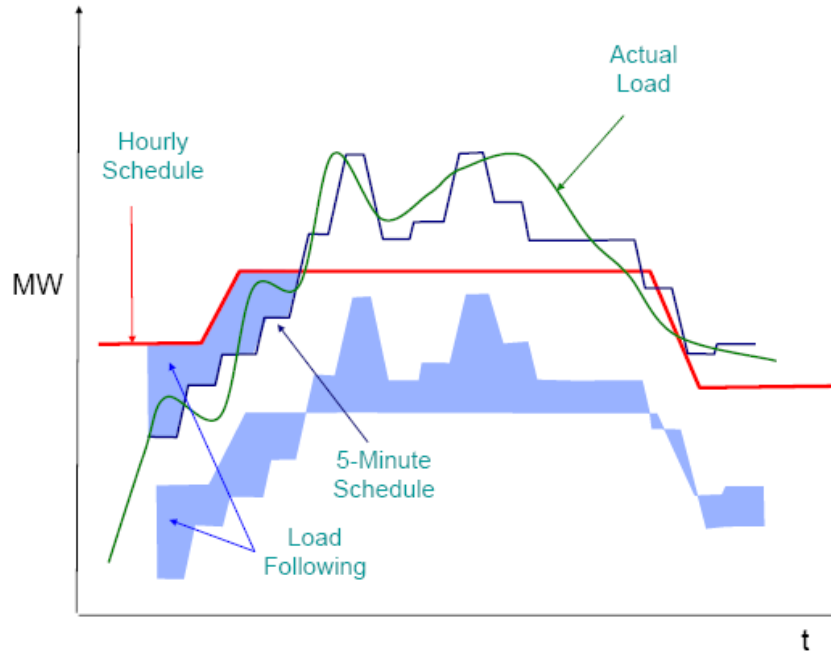

Figure 27: Depiction of hourly load-following requirement, shown as the blue area

Assessment of Ramping Requirements

The required ramping capability can be derived *ex post* from the shape of the regulation/load following curve ΔG^{rf} . The analysis uses the “swinging window”³ algorithm for this purpose. This is a proven technical solution implemented in the PI Historian and widely used to compress and store time-dependent datasets.

Figure 28 illustrates the idea of the “swinging door” approach. The set of randomly generated points in each iteration of the statistical simulation is the starting point for the analysis. The objective is to group sequences of points, such that they can be considered to have the same (or very similar) ramp rates between them for the intervals that they remain within a tolerance band. A point is classified as a “turning point” whenever for the next point in the sequence any intermediate point falls out of the admissible accuracy range $\pm \varepsilon_{\Delta G}$. For instance, for point 3, one can see that point 2 stays inside the window *abcd*. For point 4, both points 2 and 3 stay within the window *abef*. But for point 5, point 4 goes beyond the window, and therefore point 4 is marked as a turning point.

³ D.C. Barr, “The Use of a Data Historian to Extend Plant Life”, Life management of power plants, 12-14 December 1994, Conference Publication No. 401.0 IEEE 1994.

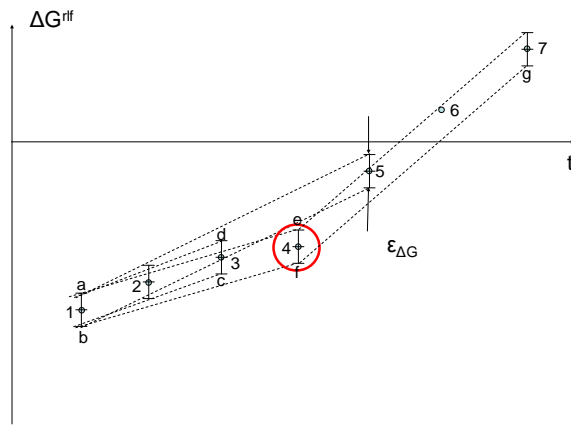

Figure 28: Concept for the "Swinging Door" Algorithm

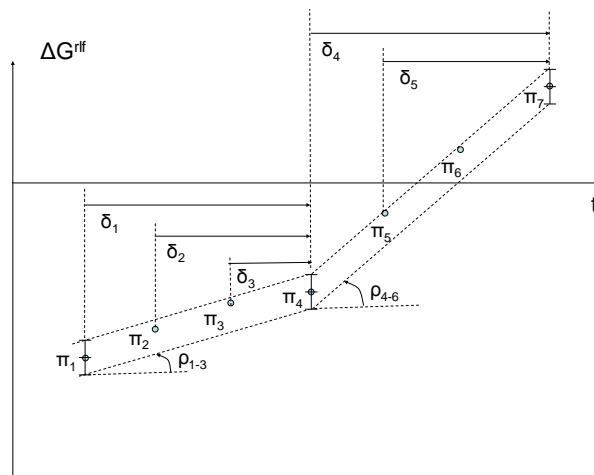

Figure 29: "Swinging Window" Algorithm – Obtaining Regulation, Ramps, and Their Duration

Based on this analysis, we conclude that points 1,2, and 3 correspond to the different magnitudes of the regulation signal, π_1, π_2 and π_3 , whereas the ramping requirement at all these points is the same, ρ_{1-3} . The swinging door algorithm also helps to determine the ramp duration δ .

Concurrent Statistical Analysis of the Regulation and Load Following Requirements

As discussed above, the regulation capacity and ramping requirements are inherently related. Insufficient ramping capability could cause additional capacity requirements.

In this document, we propose a concurrent consideration of the regulation and load following capacity, ramping and ramp duration requirements.

For the regulation/load following requirement curve ΔG^{rf} , we can apply the “swinging door” algorithm and determine the sequences of its magnitudes and ramps, π_1, π_2, \dots , ρ_1, ρ_2, \dots , and $\delta_1, \delta_2, \dots$. Figure 30 shows that the triads $(\pi_i, \rho_i, \delta_i)$ can be used to populate the three-dimensional space of these parameters.

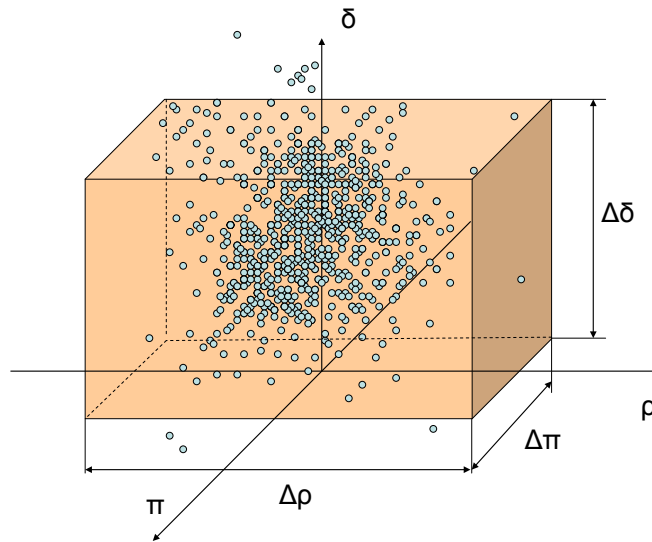

Figure 30: Concurrent consideration of the capacity, ramping and duration requirements

For given ranges of these three parameters, $\Delta\pi, \Delta\rho$ and $\Delta\delta$, a box can be plotted in this space, so that some triads are inside the box (N_{in}), some are outside (N_{out}). This approach helps to determine the probability of being outside the box,

$$P_{out} = \frac{N_{out}}{N_{out} + N_{in}}$$

If a point lies outside the box, the regulation/load following requirements are not met at this point. We will require that this probability must be below certain minimum probability, P_{\min} . The task is to find the position of the wall of the probability box that corresponds to a given P_{\min} .

Iterations of the Monte Carlo simulation

The analysis described above is conducted on a seasonal basis, with 100 iterations across each season.

Sensitivity Studies

The analysis can examine a range of sensitivities.

As noted above, the analysis can be varied to account for different mixes of resources assumed to be firmed and shaped external to the ISO BAA. In addition, the shape of the forecast error distribution can be changed to reflect improvements in forecasting.

Moreover, if the base analysis analyzes any specified portfolio results with all forecast errors, in which the analysis is of the combined wind and solar portfolio and there is no evaluation of changes in forecast error, the methodology allows for two types of further sensitivities:

1. Requirements by renewable technology, in which the simulations are re-run with and without particular technologies to distinguish the impact of incremental solar resources only, incremental wind resources only, and the full renewable portfolio; and the
2. Impact of forecast error and variability, in which the simulations are re-run to distinguish the differential effect of these factors. Essentially, this done by setting the forecast errors to zero, as described in Appendix B-9.

Presentation of simulation results

The following matrix shows the full set of results obtained from each seasonal iteration, which runs from the first minute of the first day to the last minute of the last day in the season. For a 90-day season, this is equivalent to $90 \text{ days} \times 24 \text{ hours/day} = 2,180 \text{ hours}$, each with twelve 5-minute intervals for a total of $2,180 \times 12 = 25,920$ 5-minute intervals. In each cell of the matrix, the simulation calculates the maximum load-following up and down capacity requirements as well as maximum regulation up and down capacity requirements.

	Day 1, Hour 1	Day 1, Hour 2	.	.	.	Day 90, Hour 23	Day 90, Hour 24
Iteration 1							
Iteration 2							
.							
.							
.							
Iteration 100							

The maximum hourly value for a 90 day season across all iterations is thus:

- Max (day 1, hour 1) over all 100 iterations
- Max (day 1, hour 2) over all 100 iterations
- ...
- Max (day 90, hour 23) over all 100 iterations
- Max (day 90, hour 24) over all 100 iterations

These are the 2,160 hourly values shown in the stock charts and frequency distributions.

The 24 maximums of the maximum hourly values for the season – e.g., summer, hour 1, summer, hour 2, ..., summer, hour 24 – are thus the sum over all values over all iterations for each hour:

- Max (all days, hour 1) over all 100 iterations
- Max (all days, hour 2) over all 100 iterations
- ...
- Max (all days, hour 24) over all 100 iterations

These 24 maximum values are reported for various sensitivities in the analysis where the presentation of the full distribution of seasonal hourly maximum values would not be useful.

Many of the figures in the reports represent data in the format of a “stock chart” or “whisker chart” that shows certain distribution statistics for a sample of simulated values or actual market results, typically shown by hour of season. In the example below, the top of the red or blue lines is the maximum data point in a sample, while the bottom of the red or blue lines is the minimum data point. The red and blue bars represent two standard deviations: the average plus one (1) standard deviation and the average minus one (1) standard deviation. Many of the figures, such as the one below, show these results for two simulated years that are being compared, in which case the results for each year are in different colors.

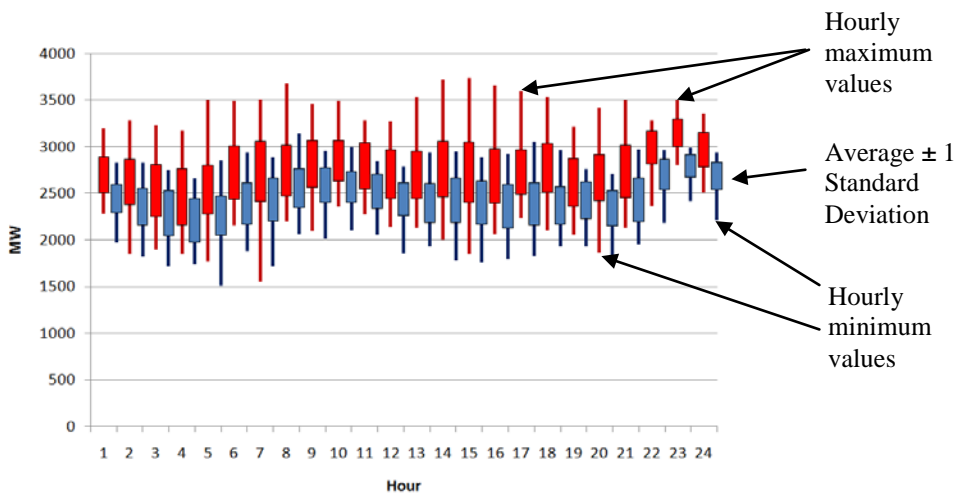

The figures in the report that use the format shown above are either measuring operational requirements in the upwards (positive) direction, which represent “incremental” energy or reserves, or in the downwards (negative) direction, which represents “decremental” energy or reserves. The figure above

is for incremental energy, hence the vertical axis (or y-axis) is measuring positive values. For figures that show decremental energy or reserves, the y-axis shows negative values and the maximum and minimum of the sample data is reversed (i.e., the maximum requirement is the most negative).

The same set of data used for the stock charts can also be presented as a frequency distribution, such as the following:

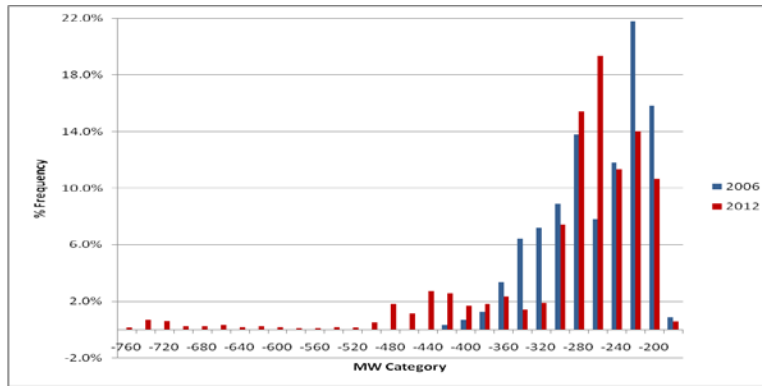

This graph makes the frequency of the values more clear, but does not indicate how the results are dispersed among the hours of the day.

Analytical flow charts for the statistical modeling

Figure 31 and Figure 32 below provide an overview of the analytical process described above.

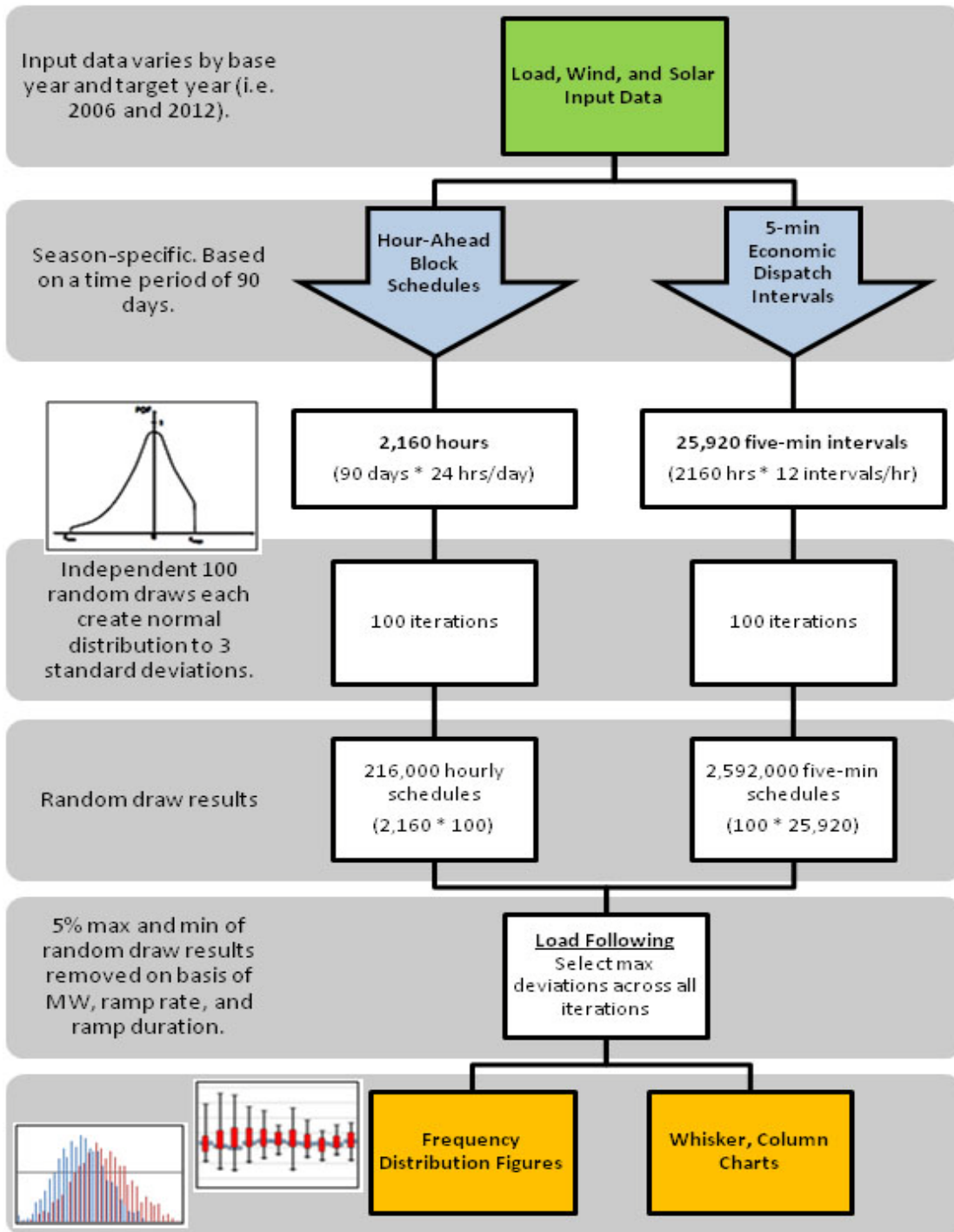

Figure 31: Analytical Flow Chart for Calculating Load-following Capacity Requirements

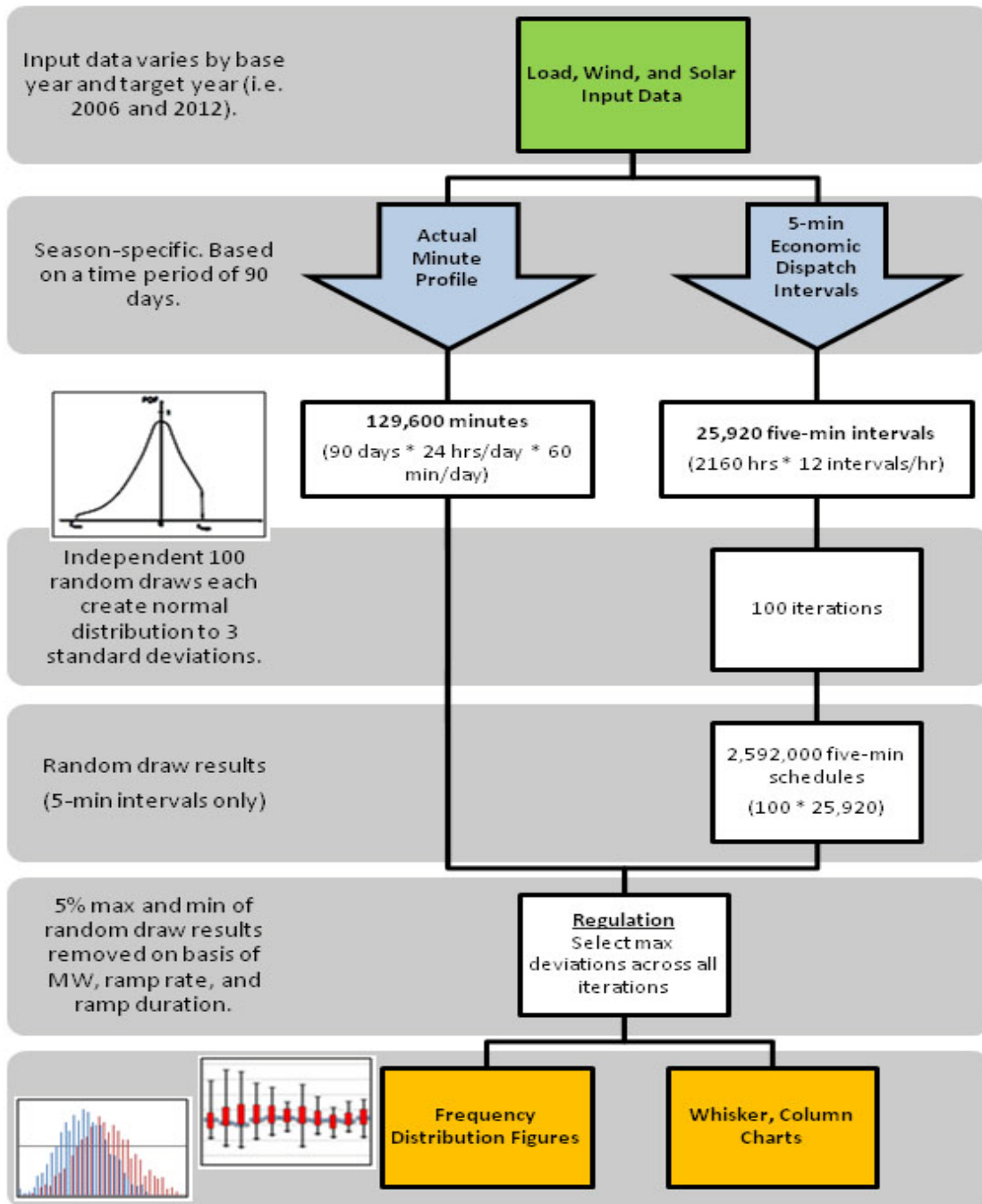

Figure 32: Analytical Flow Chart for Calculating Regulation Capacity Requirement

SECTION D

The appendices in this section provide mathematical details on the production simulation models utilized for the ISO studies as well as the modeling of certain key inputs into the models, such as the method for determining additional reserves or constraints to meet operational requirements and the method used to establish the planning reserve margin (PRM) capacity requirements and assign net qualifying capacity (NQC) to modeled resources. For additional background on the application of production simulation models in renewable integration studies, see Section 2.5 of the 20% RPS Study, which includes references to other production simulation studies.

To understand better the effects of renewable integration on generator performance and costs, which is likely to include more frequent starts, stops and cycling, a production simulation model is needed that can incorporate detailed cost functions and operating characteristics. In particular, the analysis needs to consider inter-temporal constraints, such as ramp rates, minimum down-times, and number of starts/stops. This section thus examines the full set of power system constraints being represented in the production simulation models and provides some perspective on how the models relate to actual ISO market and system operations. In this regard, there are trade-offs between accuracy and computational tractability. To conduct large numbers of simulations over varying time horizons up to one year requires some simplification of the full set of constraints, as discussed in these appendices. The ISO has undertaken some initial tests of the full market simulation software with additional renewable production to validate the feasibility of the results from the production simulation models.

Where possible, these appendices use the mathematical notation and representation adopted by the ISO for its own optimization models used in market applications. The most complete statement of the ISO's optimization models is found in the Technical Bulletin on Market Optimization Details (November 19, 2009)³³ and many additional operational details are found in the BPM on Market Operations.³⁴

There are several novel features in the methodology developed to link the production simulations with the results of the statistical models discussed in Sections B and C. The first is the addition of capacity reservations to provide the calculated requirements for regulation and load following. While a regulation requirement is a straightforward application in the model, the load-following constraint is introduced to reflect the much greater range of intra-hour variability in high renewables scenarios than is currently experienced. There is further discussion of this assumption below. A further feature is to

³³ California ISO, Technical Bulletin, 2009-06-05, Market Optimization Details, June 16, 2009, Revised November 19, 2009, available at <http://www.caiso.com/23cf/23cfe2c91d880.pdf>.

³⁴ Available at <http://www.caiso.com/17ba/17baa8bc1ce20.html>.

couple, for selected days, a day-ahead and hour-ahead unit commitment with a 5-minute dispatch simulation.

D-1 Mathematical Structure of the Production Simulation Models

This appendix reviews the structure of the dynamic (i.e., multi-period) optimization (production simulation) model used to evaluate the capability of the ISO's generation and non-generation resources to integrate alternative renewable portfolios. In addition, specific constraints are presented that have been applied in particular production simulation models used in the ISO renewable integration studies.

The general structure of the model is an objective function that specifies the variables being optimized (minimized or maximized) subject to constraints on the solution, notably energy balance, ancillary service requirements, unit operating constraints on generation and non-generation resources, other inter-temporal constraints on those resources (including environmental limits), minimum generation levels and transmission network constraints, and non-negativity and integer constraints on certain variables.

NOTE: NOTATION IN THIS SECTION IS NOT STANDARDIZED AND MAY CHANGE

Objective Function

A statement of the objective function of the unit commitment and dispatch model is represented as follows:

$$\min \sum_{h=1}^T \sum_{i=1}^N \left[\begin{aligned} & SUC_i(1 - U_{i,h-1})U_{i,h} + MLC_{i,h} U_{i,h} + \int_{P_{\min i}}^{P_{i,h}} C_{i,h}(E_{i,h}) dE + \int_{P_h=0}^{P_h} PC_h^P(E_h^{slk}) dE + \\ & C_{i,h}^{RU} \cdot RU_{i,h} + C_{i,h}^{RD} \cdot RD_{i,h} + C_{i,h}^{SP} \cdot SP_{i,h} + C_{i,h}^{NS} \cdot NS_{i,h} + C_{i,h}^{LF-Up} \cdot LF_{i,h}^{Up} + C_{i,h}^{LF-Dn} \cdot LF_{i,h}^{Dn} \\ & + PC^{RU} \cdot RU_h^{slk} + PC^{RD} \cdot RD_h^{slk} + PC^{SP} \cdot SP_h^{slk} + PC^{NS} \cdot NS_h^{slk} \\ & + PC^{LF-Up} \cdot LF_h^{Up-slk} + PC^{LF-Dn} \cdot LF_h^{Dn-slk} \end{aligned} \right]$$

Where

h Hour index

T	Total number of hours in the time horizon
i	Resource index
N	Total number of resources
Slk	Slack variable
$E_{i,h}$	Energy output of resource i in hour h
$RU_{i,h}$	Regulation up provided by resource i in hour h
RU_h^{slk}	Regulation up slack variable quantity in hour h
$RD_{i,h}$	Regulation down provided by resource i in hour h
RD_h^{slk}	Regulation down slack variable quantity in hour h
$SP_{i,h}$	Spinning Reserve provided by resource i in hour h
SP_h^{slk}	Spinning Reserve slack variable quantity in hour h
$NS_{i,h}$	Non-spinning Reserve provided by resource i in hour h
NS_h^{slk}	Non-spinning Reserve slack variable quantity in hour h
$LF_{i,h}^{Up}$	Load following up provided by resource i in hour h
LF_h^{Up-slk}	Load following up slack variable quantity in hour h
$LF_{i,h}^{Dn}$	Load following down provided by resource i in hour h
LF_h^{Dn}	Load following down slack variable quantity in hour h
$C_{i,h}(E_{i,h})$	Cost (\$/hour) as a piece-wise linear function of energy output (MW) for resource i in hour h
$C_{i,h}^{RU}$	Cost (\$/MW) of regulation up for resource i in hour h
PC^{RU}	Penalty Cost (\$/MW) for regulation up deficiency
$C_{i,h}^{RD}$	Cost (\$/MW) of regulation down for resource i in hour h
PC^{RD}	Penalty Cost (\$/MW) for regulation down deficiency

$C_{i,h}^{SP}$	Cost (\$/MW) of spinning reserve for resource i in hour h
PC^{SP}	Penalty Cost (\$/MW) for spinning reserve deficiency
$C_{i,h}^{NS}$	Cost (\$/MW) of non-spinning reserve for resource i in hour h
PC^{NS}	Penalty Cost (\$/MW) for non-spinning reserve deficiency
$C_{i,h}^{LF-Up}$	Cost (\$/MW) of load following up for resource i in hour h
PC^{LF-Up}	Penalty Cost (\$/MW) for load following up deficiency
$C_{i,h}^{LF-Dn}$	Cost (\$/MW) of load following down for resource i in hour h
PC^{LF-Dn}	Penalty Cost (\$/MW) for load following down deficiency
SUC_i	Start-Up Cost (\$/start) for resource i
$MLC_{i,h}$	Minimum Load Cost (\$/hr) for resource i in hour h
$U_{i,h}$	Commitment status; = 0 if resource i is off-line, and = 1 if resource i is on-line, in hour h

Note that in the ISO market optimization, the cost parameters, C , are bids submitted into the markets that may or may not be equivalent to a resource's marginal production costs. In addition, in the actual markets, resources can submit self-schedules or self-provide ancillary services, which appears to the market as fixed quantities treated as "price-takers". In the production simulation model, the costs of energy are based on production costs, which are largely a function of the price of the fuels and the unit heat rate assumed in the analysis. The costs of ancillary services are not based on bids or costs in production simulation, but rather on the penalty for violating ancillary service constraints. Prices for the ancillary services are determined through the shadow prices on the ancillary services constraints.

The objective function can be extended to include Ancillary Service subregions by addition of an index for each Ancillary Service region. See, e.g., BPM for Market Operations, Section 4.1.

Representation of Cost Components for Energy and Ancillary Services

Energy bids in the actual ISO markets have three cost components – Start-up cost (\$), minimum load cost (\$/MWh), and Energy costs (\$/MWh) – as well as the physical operating constraints on the unit. The first two components are considered in determining the market solution,³⁵ but are only paid explicitly through bid cost recovery³⁶ if the unit's energy and ancillary service revenues for the operating day are insufficient to cover those costs. A (price-responsive) load resource can also be represented as single or multi-part bids.

The production simulation model accounts for the start-up cost and the energy cost in the objective function, but not a minimum load cost, which is modeled as the energy cost at the minimum operating level of output. The production simulation model can represent a uniform Energy cost for the full range of production, typically based on the average actual or generic heat rates for the unit and the assumed price of gas at the location and time being modeled. Or it can represent a step-wise increasing cost function that reflects different heat rates at different levels of production. Analogous to Energy costs from generation, the simulation model can capture single or multi-part demand costs.

For the 20% RPS study, the ISO used actual heat rates based on confidential Master File data. For the 33% RPS studies, the ISO used generic heat rates that were reviewed to ensure that they appropriately reflected actual heat rates for classes of units.

The range in generator capability is from the minimum operating level (Pmin) to the maximum capacity (Pmax). This range, along with a step function for costs, is shown in Figure 33 below. Note that in the actual markets, depending on the unit type (energy-limited, not energy limited, etc.) and whether they are RA resources or not, generators can submit both Bids and schedules to account for their capability up their upper economic limit or Pmax. Unless noted otherwise, the production simulations assume that for dispatchable generation, the full range of capacity is available and dispatchable up to Pmax.

³⁵ That is, the optimization considers the total costs of the unit over the day, so that a unit with low start-up costs and high energy costs would not be started before a unit with high start-up costs and low energy costs if the latter unit was cheaper given its forecast energy production.

³⁶ See ISO, *BPM for Settlements and Billing*, Section 14.2.

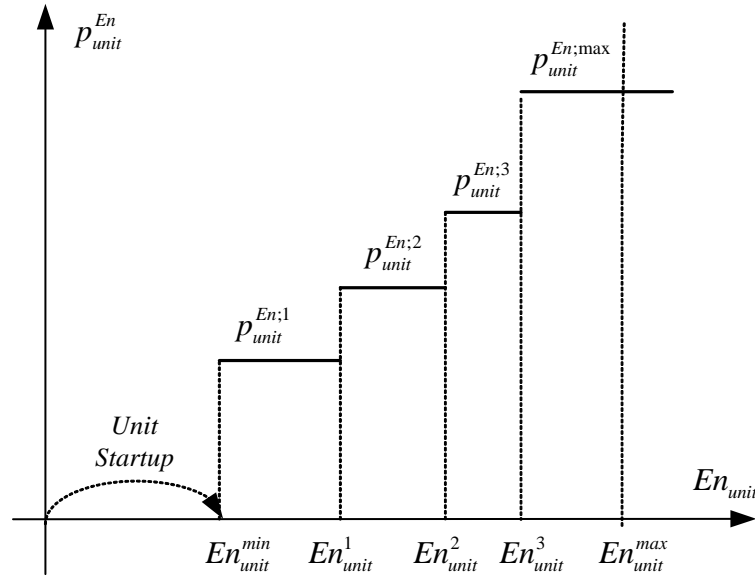

Figure 33: Generation Energy Cost Curve ³⁷

Ancillary service cost bids are submitted into the markets but are not considered in the production simulations.³⁸ However, as discussed below, simulated ancillary service costs can be calculated based on the shadow prices on the ancillary service constraints, which reflect the energy opportunity cost of providing ancillary services from on-line resources. As in the markets, the production simulations account for the ramp rate constraints on ancillary service awards to generators, measured for ancillary service-certified units as the unit-specific ramp rate (MW/min.) multiplied by the specified time domain for each ancillary service (min.).³⁹

Energy balance constraint

The energy balance or power balance constraint states that generation plus imports, adjusted for transmission losses in the system, should equal (balance) load in the ISO BAA plus exports.

$$\sum_{unit \in G} En_{unit}^t - \sum_{load \in L} En_{load}^t = En_{req}^t + En_{loss}^t ; t \in T \quad (\lambda)$$

³⁷ Source for figure: ISO, Technical Bulletin, 2009-06-05, Market Optimization Details, pg. 2-13.

³⁸ Ancillary service bids are likely to be based on factors other than fuel prices, such as natural gas storage charges, that require more complex market models. For discussion of the mathematical characteristics of ancillary service bids in the actual markets, see ISO, Technical Bulletin, 2009-06-05, Market Optimization Details, section 2.4.3. For discussion of the components of ancillary service prices, including bids, lost opportunity costs, infra-marginal rents and other factors, see California ISO, *Annual Report on Market Issues and Performance, 2009* (April 2010), pgs. 6.18-6.19; available at <http://www.caiso.com/2777/277789c42ac70.html>.

³⁹ See ISO, Technical Bulletin, 2009-06-05, Market Optimization Details, section 2.4.3.

The shadow price on the energy balance constraint (λ) is interpreted as the marginal price for energy at the system level in a transmission-unconstrained model, or the locational marginal price if the model includes nodal energy balance constraints.

Ancillary Services Constraints

In the production simulations, as in the actual wholesale markets, there are individual and joint ancillary service constraints reflecting minimum requirements for particular ancillary services in particular locations as well as substitution between provision of ancillary services to meet total system requirements. Specifically, ancillary service “cascading” is reflected, i.e., a lower quality of ancillary service can be substituted by a higher quality of ancillary service:

- Regulation Up can be substituted for both Spinning and Non-Spinning Reserves; and
- Spinning Reserve can be substituted for Non-Spinning Reserve.

The ISO also enforces ancillary service regional/subregional requirements⁴⁰ that the production simulation models have not captured explicitly to date, although as discussed below, they have accounted for provision of ancillary services from entities other than the ISO within California as well as how ancillary service requirements are met between regions in a full WECC model.

Mathematically, the system-level ancillary service constraints can be stated as follows:

Regulation Up and Down Requirements

$$\sum_{i=1\dots N, i \in AS} Reg_{unit_i}^{Up:h} + Reg_{slk}^{Up:h} \geq Reg_{ASreq}^{Up:h} ; h \in H ,$$

$$\sum_{i=1\dots N, i \in AS} Reg_{unit_i}^{Dn} + Reg_{slk}^{Dn:h} \geq Reg_{ASreq}^{Dn} ; h \in H$$

⁴⁰ Ancillary service regions are network partitions that are used to explicitly impose regional constraints in the procurement of ancillary services. These regional constraints reflect transmission limitations between ancillary service regions that restrict the use of ancillary services procured in one ancillary service region to cover for i) outages in another ancillary service region and ii) constraints between the regions. Ancillary service regional constraints secure a minimum ancillary service procurement (to ensure reliability) and/or a maximum ancillary service procurement target (that increases the probability of deliverability of ancillary services to each Region), such that the total ancillary service procurement among Regulation Up, Spinning Reserve, and Non-Spinning Reserve reflects the current system topology and deliverability needs. For further discussion, see California ISO, *Business Practice Manual for Market Operations*, section 4.1. Current ancillary service regions and sub-regions are defined in the ISO Tariff in Section 8.3.3.

Regulation Up and Regulation Down capacity requirements are established through the statistical modeling presented in Appendix B (Step 1).

Spinning Reserve Requirements

$$\sum_{i=1\dots N, i \in AS} Spin_{unit_i}^h + \sum_{i=1\dots N, i \in AS} Reg_{unit_i}^{Up:h} + Spin_{slk}^h \geq Spin_{ASreq}^h + Reg_{ASreq}^{Up:h} ; h \in H$$

Non-Spinning Reserve Requirements

$$\sum_{i=1\dots N, i \in AS} NonSpin_{unit_i}^h + \sum_{i=1\dots N, i \in AS} Spin_{unit_i}^h + \sum_{i=1\dots N, i \in AS} Reg_{unit_i}^{Up:h} + NonSpin_{slk}^h \geq NonSpin_{ASreq}^h + Spin_{ASreq}^h + Reg_{ASreq}^{Up:h} ; h \in H$$

Note that these equations do not include an explicit variable for ancillary service substitution, e.g., Regulation Up that is being counted towards the Spinning Reserve requirement.⁴¹ Also, as discussed above, the objective function as well as each ancillary services constraint can be extended to include ancillary service subregions by addition of an index for each ancillary service region and the minimum ancillary service requirements for each region, as well as a constraint to ensure that maximum system requirements are met. Other constraints on ancillary service procurement in the actual ISO markets include a maximum upward capacity constraint for each ancillary service region.

The ISO requirement for Spinning Reserves and Non-spinning Reserves is calculated within the modeling run as:

$$0.5 \times (3\% \times \text{Load} + 3\% \times \text{Generation}).$$

Load-following Reserve Requirements

A feature of the ISO integration studies of 33% RPS that does not reflect current market product definitions is a load-following capacity constraint interpreted as both (a) a constraint to ensure that an hourly time-step model can adequately cover intra-hourly variations in load as well as wind and solar production, and (b) a possible non-contingency reserve capability for the same purposes. The two alternatives are not mutually exclusive, and further analysis is needed to clarify whether an additional reserve is actually needed. There is further discussion of these alternatives in Appendix D-2.

⁴¹ In addition, note that the ISO’s technical bulletin identifies what is called a slack variable here as a “relaxation variable” used for the penalties for violation, while the term slack variable is used to identify the quantities of ancillary services that are substituted using cascading. See ISO, Technical Bulletin, 2009-06-05, Market Optimization Details, pgs. 2-24 to 2-26.

Load-following Up and Load-following Down capacity requirements are established through the statistical modeling presented in Appendix B (Step 1). The representation of this requirement is as an additional capacity reservation that is not cascaded with the other ancillary services.

The load-following requirements are represented as follows:

$$\sum_{i=1\dots N, i \in AS} LF_{unit_i}^{Up;h} + LF_{slk}^{Up;h} \geq LF_{ASreq}^{Up;h} ; h \in H ,$$

$$\sum_{i=1\dots N, i \in AS} LF_{unit_i}^{Dn;h} + LF_{slk}^{Dn;h} \geq LF_{ASreq}^{Dn;h} ; h \in H .$$

Ancillary Service Requirements for Publicly Owned Utility (POU) BAAs in California

The determinations of ancillary service and load-following requirements are based on a total CA system need. However, for modeling purposes, in the 33% RPS studies all requirements have been split between POU and ISO regions, based on the ratio of POU and ISO peak load in the target year. Only POU resources are able to provide ancillary service provisions towards the POU requirements and only ISO resources are able to provide them towards meeting ISO requirements.⁴² This separation ensures that POU generators do not carry the burden of meeting ISO system requirements. Three POU - specific ancillary service requirements are modeled via the following constraints in Plexos based on the service requirement:

- POU Regulation Requirement
- POU Operating Reserve Requirement
- POU Load Following (20-Min Ramping) Requirement

Ramp-sharing constraints

The rest of the system constraints are restrictions on individual unit's capability to provide reserves. Although all unit provisions are limited by the unit's ability to provide services individually, additional constraints are required to ensure that when a unit is providing multiple services, it adheres to its ramping capability. The provision constraints are unit-specific; therefore individual constraints must be developed for each resource that provides multiple services. The constraints used to ensure proper provision are list below:

⁴² The only exception is Hoover hydro generation, which both ISO and POU's have rights to. In the 33% RPS study, Hoover ancillary service capability was broken into two portions, one which could only be used to meet POU ancillary service requirements and the other which could only be used to meet ISO ancillary service requirements.

10-Minute Product Constraints

These set of constraints ensure that competing 10-minute products properly utilize resources' 10-minute ramping capability. Regardless of which type of 10-minute product that the unit is providing, the unit's 10-minute ramping capability cannot be exceeded.

Reg Plus Spin Constraint:

- Hourly Regulation Provision + Hourly Spin Provision \leq 10-min ramp

Reg Plus Non-Spin Constraint:

- Hourly Regulation Provision + Hourly Non-Spin Provision \leq 10-min ramp

Because all units that have spinning capability also have on-line non-spin capability, an additional constraint must be implemented on each unit to ensure the non-spin provision is constrained the same way that the spin provision is constrained.

20-minute Product Constraint

These set of constraints ensure that simultaneous provision of 10-minute products and the 20-minute ramping product is accurately represented on units. These constraints ensure that the sum of all provisions will not exceed the 20-Minute ramping capability on the unit:

Reg Plus Spin Plus 20-Min Ramping Constraint:

- Hourly Regulation Provision + Hourly Spin Provision + Hourly 20-Min Ramping Product \leq 20-min ramp

Reg Plus Non-Spin Plus 20-Min Constraint:

- Hourly Regulation Provision + Hourly Non-Spin Provision + Hourly 20-Min Ramping Product \leq 20-min ramp

Because all units that have spinning capability also have on-line non-spin capability, an additional constraint must be implemented on each unit to ensure non-spin provision is properly constrained.

10-minute Ramping Check

Although a unit can provide spin, non-spin, regulation, and 20-min ramping simultaneously, a unit is most constrained by its 10-min capability, not its 20-min capability. A unit must maintain a consistent ramp through-out the 20 minute ramping period, and this consistent ramp is determined in the first 10-minute window.

For example, if a unit has a ramp rate of 1MW/min, and receives a 10 MW Regulation award, it cannot provide an additional 10 MW of 20-Min Ramp. Because the unit has used up its entire ramping capability in the first 10 minute window (to provide the maximum amount of regulation), will not be able to use the next 10 minute window to

provide a 20-min ramping product. The 20-min ramping product needs the full 20 minutes to complete ramping. Therefore, we know that 50% of the 20-min ramping provision must be provided in the first 10-min window.

10-Min Ramp Check Constraint (Spin):

- Hourly Regulation Provision + $2/3 * (\text{Hourly Spin Provision} + \text{Hourly 20-Min Ramping Product}) \leq 10\text{-min ramp}$

10-Min Ramp Check Constraint (Non-Spin):

- Hourly Regulation Provision + $2/3 * (\text{Hourly Non-Spin Provision} + \text{Hourly 20-Min Ramping Product}) \leq 10\text{-min ramp}$

These equations model the interaction of spin, non-spin, and 20-min ramping, while allowing for some level of ramp-sharing between operating reserves and 20-min ramp, which corresponds to current CAISO market operations.

Because all units that have spinning capability also have on-line non-spin capability, an additional constraint must be implemented on each unit to ensure non-spin provision is properly constrained.

Penalty costs for constraint violations

As noted above, the optimization assigns a penalty cost (also called a “penalty factor”) to the violation of the “soft” constraints, including the power balance constraint and the ancillary service requirement constraints. The penalty cost is a parameter specified by the modeler to implement relative priorities for enforcing various constraints or categories of constraints. A higher penalty cost assigned to a slack variable(s) in a constraint typically means that this constraint will be violated subsequent to a constraint with a slack variable assigned a lower penalty cost. Hence, if the penalty cost for violating the Regulation Up requirement is less than the penalty cost for violating the Spinning Reserve requirement, then the model solution will seek to preserve Spinning Reserve over Regulation Up. The magnitude of the penalty also determines the frequency that a violation will occur; for example, in actual ISO market operations, the “scheduling run” of the unit commitment model uses values for the penalty costs that are significantly higher than the cap on market bids to ensure that all market bids are used prior to the violation of self-schedules.

Penalty costs are also determined by the number and type of constraints being modeled. A larger number of priorities for enforcing different constraints requires that penalties are adjusted accordingly, and hence will take on values that are increasingly structured by the objectives of the simulation rather than by a reflection of actual value to the market in meeting certain constraints in a particular order.

FURTHER INFORMATION ON THE PENALTIES WILL BE PROVIDED IN THE NEXT DRAFT

Other generation unit inter-temporal constraints

This section reviews other generating unit inter-temporal constraints (in addition to ramp rates), adapting the relevant sections in the ISO’s Technical Bulletin on *Market Optimization Details* and noting any differences between the market model and the production simulation models. With the increased cycling of thermal generation anticipated at higher levels of variable energy resource production, accurate representation of these inter-temporal constraints is important for production simulation. The constraints discussed here are:

- Start-up time
- Maximum number of daily start-ups
- Minimum Up Time
- Minimum Down Time
- Daily energy limits

Further discussion of particular unit types follows.

Start-Up Time

The unit Start-Up Time (SUT) is usually dependent on the cooling time, i.e., the time a unit needs to start up depends on how much time the unit has been offline. Therefore, the total down time consists of the cooling time and the Start-Up Time, which is dependent on the cooling time. The total down time is enforced to be no shorter than the Minimum Down Time, as discussed below. The cooling, startup and down time relationship is illustrated on the following figure:

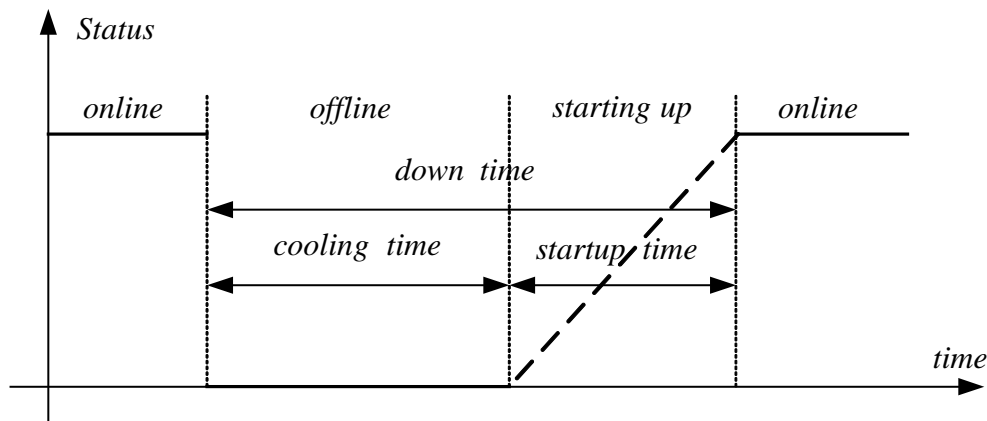

Figure 34: Cooling, Startup, and Down Time ⁴³

In the actual markets, there are three cooling statuses: hot, intermediate and cold. These statuses are presented by separate segments of the Start-Up Time function. These

⁴³ Source for figure: ISO, Technical Bulletin, 2009-06-05, Market Optimization Details, pg. 2-32.

segments are the same as segments of the Start-Up Cost function. The Start-Up Time function is a monotonically increasing staircase curve of Start-Up Cost versus cooling time. This three-segment function is illustrated in the following figure:

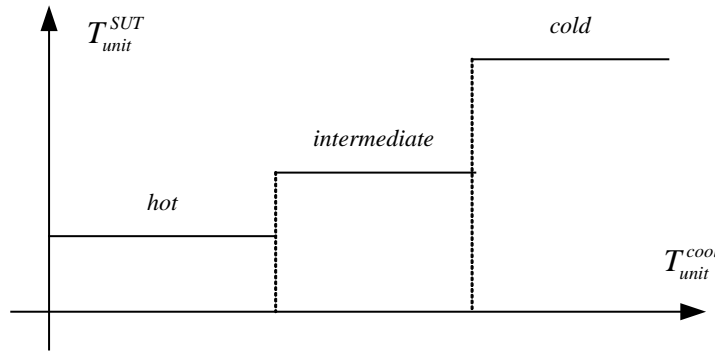

Figure 35: Startup Time Function ⁴⁴

Maximum Number of Daily Start-Ups

The maximum number of daily Start-Ups is limited by a specified number, and is accounted for in the production simulation.

Minimum Up Time

Typically, a generating unit cannot change its commitment status in every time interval. It must stay online or offline for some minimum time period without changing its commitment status. The Minimum Up Time constraint, specified in minutes, is the minimum amount of time that a unit must stay online between Start-Up and Shut-Down. The Minimum Up Time constraint is included in the production simulation model.

Minimum Down Time

The Minimum Down Time constraint, specified in minutes, is the minimum amount of time that a unit must stay offline after the start of Shut-Down, including Shut-Down time and Start-Up Time. It must stay off-line at least for indicated time intervals. The production simulation accounts for Minimum Down Time.

Daily Energy Limits

Energy limit constraints apply to a prescribed list of Generating Units that can generate a limited amount of Energy for a given period of time. In the actual markets, energy-limited Generating Units must indicate an energy limit in their day-ahead market Bids that applies to their Schedule and Dispatch throughout the Trading Day. The units are responsible for meeting their Energy Limit requirements for longer time periods, such as

⁴⁴ Source for figure: ISO, Technical Bulletin, 2009-06-05, Market Optimization Details, pg. 2-32.

weekly, monthly or seasonal, subject to any applicable Resource Adequacy requirements. Ancillary service awards are not constrained by Energy Limits.

The total available Energy can be determined by long-term hydro or fuel scheduling. This limited Energy is optimally distributed over the scheduling period. Environmental limitations (e.g. air emissions etc) is also a reason for a generating unit being energy limited. Furthermore, there could other factors as well leading to use-limitation of a resource.

In general, the production simulations can observe energy limitations in two ways: (1) by using historical data as a basis for fixed schedules for the energy-limited generator; (2) by applying additional constraints to reflect energy limits. See discussion below.

General Assumptions about Dispatchability of Generation Types

Each study will clearly describe the assumptions about the dispatchability of generation types, by fuel source and contract type, and of particular units within each type.

Modeling of Combined Cycle Generation

Combined cycle generation comprise a large [approx. 13,700 MW] and likely growing share of the California gas fleet and hence a significant contributor to the provision of integration capability. By 2020, the ISO's 33% RPS cases assumes large scale retirement of once-through-cooling units, as well as other units, and, for modeling purposes, these resources were replaced with new multi-stage combined cycle combustion turbines with updated flexibility characteristics. These existing and new CCGTs were not modeled as inflexible resources in the production simulations. However, the ISO was not able to model them in the detail required to represent of all their configurations, as has been developed for the actual ISO markets.⁴⁵ For example,

⁴⁵ The operational capabilities of multi-stage generating (MSG) resources are similar to an aggregation of individual units. In fact, many are aggregations of sub-resource generating units. As a result, they can provide valuable flexible generation to the system, but they also are more complex to accurately model and dispatch. Specifically, these MSG units often have output ranges in which they cannot operate. That is, between their minimum and maximum operating levels, there are output levels at which the units cannot be dispatched. Transitioning between operating these operating ranges, or configurations, is costly, takes time, and should be done a limited number of times each operating day. To achieve the most flexible commitment and dispatch of the units, the ISO will allow plants to be bid in with multiple possible configurations that the market software will optimize given forecast conditions. For documentation on the ISO's MSG unit modeling functionality, see the ISO Draft Final Proposal at <http://www.caiso.com/23a8/23a8e0d123ea0.pdf>, and the External Business Requirements Specifications, at <http://www.caiso.com/2408/2408cafb90f0.pdf> (see section 3.1).

the ISO did not model CCGTs as having different ranges of operation and with the potential for different ramp rates for each range. Rather, the resources were modeled with a single ramp rate over a single dispatchable range. The ramp rate was set to provide an approximation of the ramping over the entire range. In addition, the CCGTs in the simulations have startup (cold) and shutdown times that range from 2-5 hours for startup and 1-2 hours for shutdown.

Modeling of hydro and pumped storage

Modeling of hydro systems and pumped storage will vary between studies. The 20% RPS Study (August 2010) modeled all hydro resources based on fixed schedules and actual production in two base-years, a high hydro year (2006) and a low hydro year (2007). Pumped storage was also modeled as fixed generation schedules (with pumping included in the ISO load data).

The 33% RPS studies assume more flexible hydro modeling, in which the hydro systems of Northern and Southern California are modeled as a combination of run of river plants modeled as fixed profiles and the remaining plants which are dispatchable. The mix of run of river and dispatchability was based on data from a historical base year (2005). The remaining modeling assumptions for the 33% RPS studies are as follows:

Dispatchable Hydro

Dispatchable hydro resources located in California are aggregated into two resources: NP15 Dispatchable Hydro and SP15 Dispatchable Hydro. The resources have to meet a weekly total energy target constraint for both zones for every week in the target year (2020).

Pump Storage Modeling

Pumped storage plants are modeled to allow starts in the pump and generate mode and to provide load following and ancillary services (Regulation and reserves) in the generation mode. The number of starts constraint ensures that pump storage units pump no more than once per day. There is a further constraint to ensure that at the end of each day, the minimum target amount of water in the pump storage reservoir is met.

Minimum generation constraints

SCE and SDGE regions have operating procedures for system grid stability currently implemented by the ISO that require some level of minimum generation to serve that region's load. The effect of this minimum generation requirement is a restriction on imports into those regions.

The SCE 70/30 Import Limitation constraint requires that 30% of SCE's hourly load must be met by SCE territory thermal generators.

The SDGE 75/25 Import Limitation constraint requires that 25% of SDGE's hourly load must be met by SDGE territory thermal generators.

The ISO's 20% RPS Study did not enforce these constraints, but the 33% RPS production simulations are doing so. Enforcing these constraints will affect the potential for overgeneration in the ISO BAA.

Network constraints

In the actual markets and scheduling procedures, the ISO uses a full network model for its BAA that includes an AC power flow solution, which is then linearized for use in the security-constrained unit commitment processes and the real-time security-constrained economic dispatch. The procedure for modeling the network is described in detail in a number of sources.⁴⁶

For production simulations, the level of network modeling, both in terms of the detail within the ISO BAA and the representation of the rest of the WECC, can significantly increase solution times. In addition, the operational studies to date have not sought to examine in great detail the impact of congestion or line losses on integration. Hence, the ISO has heretofore used simplifications of the network models in the operational aspects of the integration studies discussed here.

The 2010 Study of 20% RPS used a two zone model of the ISO BAA.

The study of 33% RPS utilizes a zonal model of the WECC.

Subsequent renewable integration studies could use more detailed network models. For example, the ISO's transmission planning department uses a production simulation model with a DC load flow model of the entire WECC for hourly simulations over periods up to one year that account for congestion. However, that model does not conduct unit commitment with start-up costs, does not co-optimize energy and ancillary services, and does not offer the option to do 5-minute time-intervals, all of which are useful for the operational analysis.

⁴⁶ See ISO, Technical Bulletin 2009-06-05, Market Optimization Details, section 2.5.3;

D-2 Determination of Load-following and Regulation Capacity Requirements

This appendix discusses alternative criteria for calculating and including the load-following and regulation capacity requirements calculated in the statistical analysis (Step 1, Sections A and B) in the production simulation model. As discussed in appendix C-1, these additional reserves are likely to be procured on an hourly basis, but with constraints that reflect the capability to deploy such reserves on a sub-hourly basis. In the current ISO day-ahead markets, the ISO procures regulation and operating reserves on an hourly basis, but with constraints and operational requirements that include speed and duration of response). Similarly, the production simulation model can reflect hourly reservations of ancillary services and other capacity reservations that are intended for sub-hourly deployment, with the option to evaluate sub-hourly response for some capabilities (as discussed below).

There are alternative ways to calculate these requirements and then reflect them in the production simulation. Table 9 shows the decisions on how to represent load-following and regulation capacity constraints, based on alternative input and output (results) decisions from the statistical modeling described in Appendix C. Note that the speed (ramp rate) of response is not captured in the capacity constraint, but would have to be evaluated through the imposition of ramp constraints in the optimization model or other models that might be utilized.

Table 9: Key Dimensions of Load-following Capacity Constraints

	Description	Primary Options Considered
1. Forecast error assumption [<i>input to statistical model</i>]	The operational requirements simulation can vary the assumed forecast errors from zero to the current distribution of forecast errors. See appendix B-9	<ul style="list-style-type: none"> • Forecast errors based on current levels • Improvements in current forecast errors • No forecast errors (to benchmark the impact of forecast errors)
2. Statistical range of requirements modeled [<i>output of statistical model</i>]	The statistical models generate a distribution of capacity requirement values, reflecting the random draws from the distribution of forecast errors. The current methodology uses the 95 th	<ul style="list-style-type: none"> • 95th percentile of values • Average \pm 1 standard deviation (resulting in 83 percent of values for a normal distribution) • Other assumptions

	<p>percentile of the values. Other sensitivities could evaluate other ranges of values, such as two standard deviations, to evaluate the system as if the ISO is using other means (e.g., renewable dispatch) to address the requirements outside that range). However, the implication of carrying less than the 95th percentile is either (a) that reliability standards are being relaxed, or (b) that renewable energy is being curtailed such that the lower requirement is sufficient.</p>	
<p>3. Hourly values modeled [<i>output of statistical model</i>]</p>	<p>The hourly values for the load-following capacity requirements can be used by hour of year or at some other level of aggregation, such as seasonal maximum hourly value</p>	<ul style="list-style-type: none"> • Hourly simulated values for all hours (i.e., hours 1 to 8760) • Seasonal maximum hourly values (i.e., hours 1 to 24)
<p>4. Residual vs. total load-following requirement [<i>output of statistical model; ex ante evaluation of load-following requirements in production model</i>]</p>	<p>In any particular hour, the hourly commitment and dispatch schedule will contain some inherent load-following capability, as a function of the dynamic optimization and system constraints being modeled. The hourly load-following capacity requirement from the statistical model is an total hourly requirement independent of what the “next” hour. The load-following capacity reservation can thus either be modeled as a total or residual requirement. The total requirement is much simpler to model; the</p>	<ul style="list-style-type: none"> • Total hourly load-following capacity requirement • Residual hourly load-following requirement, evaluated ex ante.

	residual requirement would require some ex ante rule for measurement (see discussion, this section).	
--	--	--

Similarly to the load-following capacity requirements, Table 10 shows that the regulation capacity requirements could be modified under similar assumptions, with the exception that there is no inherent Regulation capability in the dispatch that could be measured.

Table 10: Key Dimensions of Regulation Capacity Constraints

	Description	Primary Options Considered
1. Forecast error assumption [<i>input to statistical model</i>]	The operational requirements simulation can vary the assumed forecast errors from zero to the current distribution of forecast errors. See appendix B-9	<ul style="list-style-type: none"> • Forecast errors based on current levels • Improvements in current forecast errors • No forecast errors (to benchmark the impact of forecast errors)
2. Statistical range of requirements modeled [<i>output of statistical model</i>]	The statistical models generate a distribution of capacity requirement values, reflecting the random draws from the distribution of forecast errors. The current methodology uses the 95 th percentile of the values. Other sensitivities could evaluate other ranges of values, such as two standard deviations, to evaluate the system as if the ISO is using other means (e.g., renewable dispatch) to address the requirements outside that range). However, the implication of carrying less than the 95 th percentile is either (a) that reliability standards are being relaxed, or (b) that	<ul style="list-style-type: none"> • 95th percentile of values • Average \pm 1 standard deviation (resulting in 83 percent of values for a normal distribution) • Other assumptions

	renewable energy is being curtailed such that the lower requirement is sufficient.	
3. Hourly values modeled [<i>output of statistical model</i>]	The hourly values for the load-following capacity requirements can be used by hour of year or at some other level of aggregation, such as seasonal maximum hourly value	<ul style="list-style-type: none"> • Hourly values for all hours (i.e., hours 1 to 8760) • Seasonal maximum hourly values (i.e., hours 1 to 24)

D-3 Determination of Planning Reserve Margin and Net Qualifying Capacity for Generation Resources

For operational studies that require determination of net qualifying capacity to meet a planning reserve margin (e.g., 33% RPS operational studies), the ISO will use methodologies and assumptions consistent with regulatory and operational practice at the time of the study.

To calculate the NQC of additional gas resources, the ISO has assumed nameplate capacity.

For wind and solar resources, the ISO has used the CPUC exceedance methodology based upon regulatory approach applied to the target year, which measures the production that is exceeded in 70% of the peak hours in the peak summer month (July in the 33% RPS study). The resource profiles for the target year are the same annual (8760 hours) profiles used in the statistical and production simulation modeling. The ISO also calculates the system diversity benefit and allocates capacity to individual plants on a pro-rate basis.

D-4 Structure of a Stochastic, Sequential Production Simulation for Selected Days

The analytical flow of the stochastic, sequential production simulation methodology is depicted in Figure 36. The first step in this methodology is the simulation of the day-ahead market with a day-ahead load and wind forecast. The model did not include a day-ahead solar forecast, but rather modeled solar production as a fixed hourly profile. The day-ahead market simulation is an hourly simulation for the entire study year (8760) hours. This simulation is performed 100 times using the day-ahead load and wind

generation forecast errors described in the previous section. This simulation uses a 24-hour optimization window, with a 24-hour look-ahead to account for long-start units.

The next step in the sequential simulation is the “hour-ahead” simulation which lines up in time with the ISO’s hour-ahead scheduling procedure and with the submission of wind schedules in the Participating Intermittent Resource Program. The commitment status for the extremely long- and long-start generators are passed from the day-ahead simulation and frozen in the hour-ahead simulation. As in the case of the day-ahead simulation, the hour-ahead simulation is an hourly simulation for the entire study year (8760) hours. This simulation is performed 100 times using the hour-ahead load and wind generation forecast errors. The day-ahead and hour-ahead load and wind generation forecast errors are correlated. This simulation uses a 6-hour optimization window. The hourly unit commitment status for the extremely long-, long-, medium-, and quick-start generators are queried by iteration from the solution and passed to the “real-time” 5-minute simulations, which are described next. The definitions of start-times are shown in Table 11.

In the real-time simulation unit commitment and dispatch, the resource and network data are the same as that in the day-ahead and hour-ahead simulations. The loads and variable energy resource generation are the “actual” data prior to the introduction of forecast errors, and averaged from the underlying 1-minute data to the 5-minute intervals. The solution is the co-optimization of energy and ancillary services with generation unit commitment and dispatch.

Table 11: Definitions and characteristics of units based on start-times

Attribute	Fast-Start	Short-Start	Medium-Start	Long-Start	Extremely Long-Start
Start-up Time	Less than or equal to 10 minutes	Less than 2 hours	Between 2 & 5 hours	Between 5 & 18 hours	Greater than 18 hours
Cycle time		Less than 5 hours	Less than 5 hours		

To reduce the computational burden, a selected number of days that exhibited interesting operational challenges were selected for this detailed simulation process to examine the impact on load-following and overgeneration. To identify these days or hours, the ISO undertook a variant on what is called “importance sampling.”⁴⁷ This is a method for choosing most likely scenarios, or in this case, most likely periods for ramp violations, ancillary service shortfalls, or overgeneration events. The procedure used to identify interesting days for real-time simulations is described below.

⁴⁷ See, e.g., description as applied to the ISO’s Transmission Economic Assessment Methodology (TEAM), (2004), pg. 5-8.

The sequential model is not attempting to model optimal unit commitment in the presence of uncertainty. That type of analysis is being undertaken by many researchers, including some working with the ISO, and may ultimately be adopted for application in ISO unit commitment algorithms. However, the ISO markets are not currently solved for optimal unit commitment in the presence of uncertainty, and so the process developed here can be interpreted as a type of stress test of a day-ahead to real-time unit commitment and load-following process that generally reflects the current procedures.

Selection of Days to Model

A combination of statistical data analysis, generation schedules, and results from deterministic and stochastic production simulations was used to find “interesting” periods during the year for more extensive analysis. These periods included

- Days when real-time net load ramp up and down events far exceeded the average hourly scheduled (forecasted) ramp
- Days when real-time net load ramp up and down events are a high percentage of the hourly flexible generation
- Days with low amounts of dispatchable generation
- Days with Dump Energy in the stochastic hourly simulations
- Days with regulation and spin shortfalls in the hourly stochastic simulation

The full description of the selection process can be found in Appendix C of the ISO August 2010 report on renewable integration.

Day-Ahead and Hour-Ahead Forecasts

To establish day-ahead and hour-ahead hourly load forecasts net of forecast variable energy resource production, the ISO used a stochastic process that is described in Appendix D-5, below.

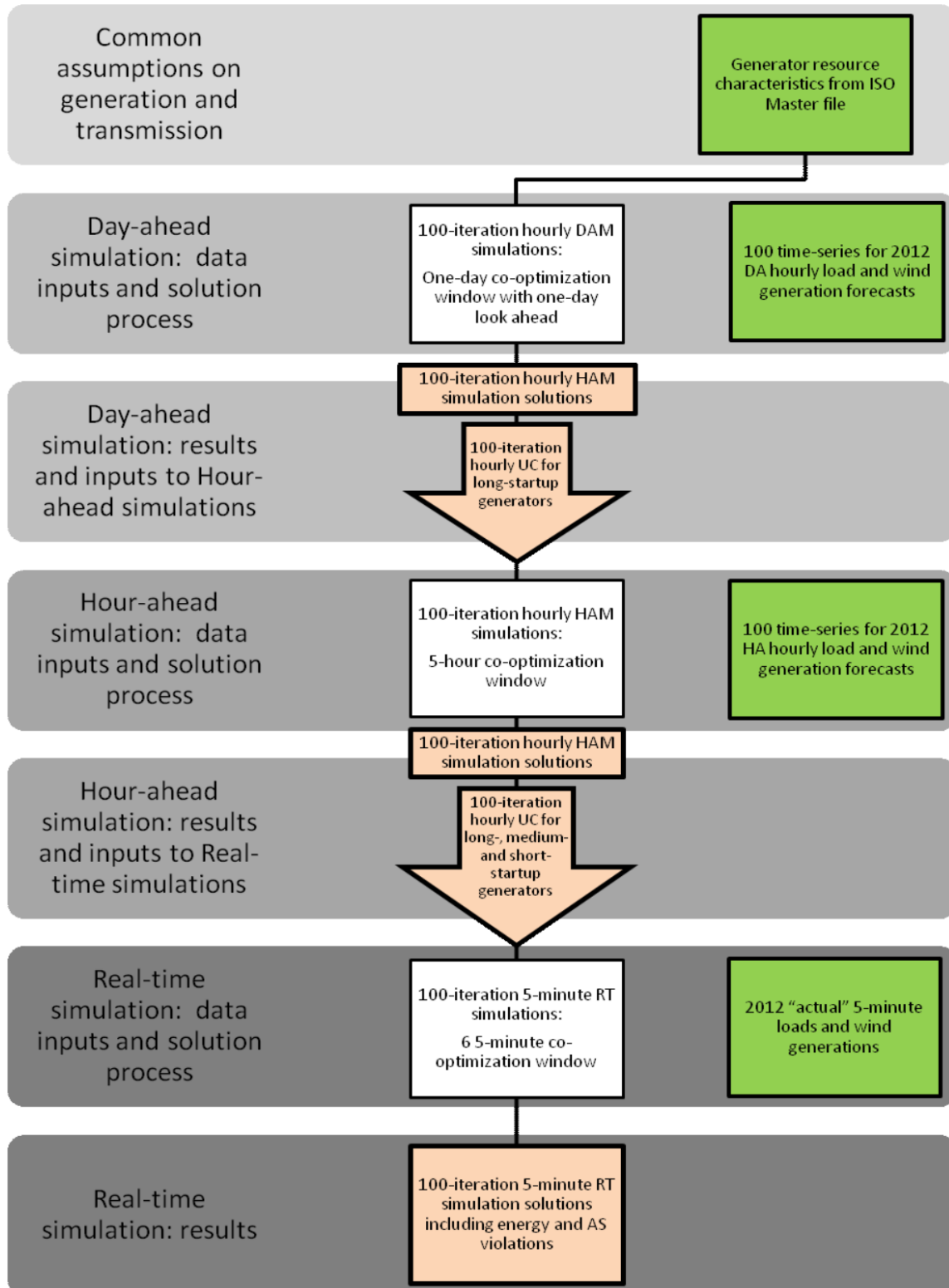

Figure 36: Flowchart of the Stochastic, Sequential Production Simulation Methodology

D-5 Stochastic Modeling of Day-ahead and Hour-ahead Wind and Load Forecasts for Production Simulations

In the sequential stochastic simulation, the ISO sought to represent a day-ahead commitment with day-ahead wind and load forecast errors, followed by an hour-ahead re-commitment with hour-ahead wind and load forecast errors. To do this, a stochastic process was defined to generate a different wind and load “forecast” for 100 iterations of the model. These time-series were initially calculated for all hours of the year, but later focused on the few selected days as described in Appendix D-4.

The time-series were generated by using a 1-lag auto-regression model defined as

$$x_t = \varphi \cdot x_{t-1} + \gamma_t \cdot S \cdot P_t,$$

Where:

x_t - Stochastic variable at time t

φ - 1-lag parameter

γ_t - A normally distributed random number

P_t - Expected value of x_t . The actual wind generation was used as the expected value for wind forecasts, and the actual load as the expected value for the load forecasts.

S - Volatility

The 1-lag parameter and the volatility are derived from the statistic analysis of the historical wind forecasts or load forecasts.

Let us assume that a time-series of a historical forecast is $\{x_t\}$. We will define the time series differences as

$$\Delta x_t = x_t - x_{t-1}.$$

Then the 1-lag parameter is defined as

$$\varphi = \mathbf{1} - \frac{\sum (x_t - \bar{x})(\Delta x_t - \overline{\Delta x})}{\sum (x_t - \bar{x})^2}$$

Where

\bar{x} is the mean of the historical time-series $\{x_t\}$;

$\overline{\Delta x}$ is the mean of the historical time series difference $\{\Delta x_t\}$.

The Volatility is defined as

$$S = \sqrt{\frac{1}{(n-2)} \left[\sum (\Delta x_t - \overline{\Delta x})^2 - \frac{\left[\sum (x_t - \bar{x})(\Delta x_t - \overline{\Delta x}) \right]^2}{\sum (x_t - \bar{x})^2} \right]}$$

The 1-lag parameters and volatilities for the wind forecasts and load forecasts are input into the PLEXOS stochastic data model to generate the 100 time-series for the estimated day-ahead and hour-ahead wind and load forecasts. The wind forecasts were generated for 5 zones in ISO in both time-frames. The 100 time-series for load forecasts were generated for the three IOU’s: PG&E, SCE and SDGE in both time-frames. Also the historical correlation of wind-wind, wind-load, and day-ahead to hour-ahead are incorporated in the PLEXOS stochastic model to model the correlation of the wind and load forecast across time and locations.

The attached tables show the comparison of the stochastic characteristics for some historical and generated wind and load forecast errors.

Table 12: Wind forecast error statistics, comparison of historical vs. modeled results

Wind forecast error	Historical	from PLEXOS simulation
Auto-Correl	0.931651341	0.927528516
Mean	-0.007516939	0.004334116
Std	0.136171658	0.10470264
Max	0.461521959	0.458775022
Min	-0.423846301	-0.478873239

Table 13: Load forecast error statistics, comparison of historical vs. modeled results

PGE summer load forecast error	Historical	from PLEXOS simulation
Auto-Correl	0.91738836	0.913625413
Mean	0.001814623	0.000441182
Std	0.052922081	0.05004967
Max	0.173475156	0.099688034
Min	-0.514301879	-0.099688034

Notes:

1. The forecast error is defined as the difference of the forecast value and the actual value in the real time market. Also the forecast errors are normalized by the actual values.
2. The truncated normal distribution is used for the stochastic simulation of the load forecast, and the second table shows the 10% of maximum and minimum of the load forecast errors.

References:

George Box, Gwilym M. Jenkins, and Gregory C. Reinsel. *Time Series Analysis: Forecasting and Control*, third edition. Prentice-Hall, 1994.

Pandit, Sudhakar M. and Wu, Shien-Ming. *Time Series and System Analysis with Applications*. John Wiley & Sons, Inc., 1983

EnergyExeplar, <http://www.plexos.info/wiki/index.php?n=Main.Variable>, PLEXOS on-line help.

Table 14: Day-ahead load forecast statistical characteristics, PG&E region

Day-ahead Load Forecast (Year 2006 and 2007)				
	PGE Winter	PGE Spring	PGE Summer	PGE Fall
Observations	4320	4416	4416	4368
Mean	1.0022798	1.0007347	1.0089969	1.0077078
STDEV	0.0247019	0.0286191	0.0315712	0.0265371
Max	1.1193501	1.1441233	1.1407363	1.1622241
Min	0.8880422	0.869694	0.8868078	0.8683719
AutoCorrel	0.8122318	0.7685619	0.8640994	0.7872226

Table 15: Hour-ahead load forecast statistical characteristics, PG&E region

Hour-ahead Load Forecast (Year 2006 and 2007)				
	PGE Winter	PGE Spring	PGE Summer	PGE Fall
Observations	4320	4416	4416	4368
Mean	1.0031263	1.0039973	1.0066398	1.0055731
STDEV	0.0184548	0.0238829	0.0207146	0.0206028
Max	1.1078289	1.1444123	1.1276044	1.1627447
Min	0.9020543	0.8850656	0.8372179	0.9029428

AutoCorrel	0.5956291	0.6250548	0.5865422	0.6085548
------------	-----------	-----------	-----------	-----------

Table 16: Day-ahead load forecast statistical characteristics, SDG&E region

Day-ahead Load Forecast (Year 2006 and 2007)				
	SDGE Winter	SDGE Spring	SDGE Summer	SDGE Fall
Observations	4320	4416	4416	4368
Mean	0.9976146	1.0006142	1.004731	1.0077721
STDEV	0.0257427	0.0299539	0.0411335	0.0325292
Max	1.3333333	1.1688453	1.2742557	1.1644899
Min	0.8842365	0.84636	0.8234519	0.8590741
AutoCorrel	0.7253184	0.8181903	0.9357658	0.8828126

Table 17: Hour-ahead load forecast statistical characteristics, SDG&E region

Hour-ahead Load Forecast (Year 2006 and 2007)				
	SDGE Winter	SDGE Spring	SDGE Summer	SDGE Fall
Observations	4320	4416	4416	4368
Mean	1.0003542	1.0013894	1.0021171	1.0022506
STDEV	0.0231055	0.0270219	0.022999	0.0224828
Max	1.3300813	1.1568528	1.1288952	1.1389812
Min	0.8427854	0.8459134	0.8285011	0.8525011
AutoCorrel	0.5362315	0.7254527	0.7140222	0.6560638

Table 18: Day-ahead load forecast statistical characteristics, SCE region

Day-ahead Load Forecast (Year 2006 and 2007)				
	SCE Winter	SCE Spring	SCE Summer	SCE Fall
Observations	4320	4416	4416	4368
Mean	1.0035783	1.0044979	1.0100746	1.0058827
STDEV	0.0205561	0.0243568	0.0344689	0.0294687
Max	1.0954712	1.1673274	1.1655857	1.1811493
Min	0.9262047	0.8944292	0.8652504	0.8646465
AutoCorrel	0.8212987	0.7858544	0.9197287	0.8741253

Table 19: Hour-ahead load forecast statistical characteristics, SCE region

Hour-ahead Load Forecast (Year 2006 and 2007)				
	SCE Winter	SCE Spring	SCE Summer	SCE Fall
Observations	4320	4416	4416	4368
Mean	1.007569	1.0031697	1.005166	1.006848
STDEV	0.0231317	0.0209133	0.0220598	0.0237412
Max	1.1641162	1.168679	1.1350708	1.1629012
Min	0.8972268	0.877837	0.8434199	0.8969626
AutoCorrel	0.6811505	0.597747	0.708283	0.6377826

Table 20: Day-Ahead and Hour-Ahead Wind Generation forecast characteristics

	Wind DA	Wind HA
Observations	4159	4159
Mean	-0.5%	2.2%
STDEV	12.5%	9.4%
Max	46.0%	36.2%
Min	-50.4%	-39.1%
AutoCorrel	0.9265	0.8323

Table 21: Cross-correlation between Day-Ahead and Hour-Ahead load forecast errors

Average	PGE DA	SCE DA	SDGE DA	PGE HA	SCE HA	SDGE HA
PGE DA	0.806308	0.299013	0.229093	0.681151	0.186976	0.191191
SCE DA		0.850265	0.546055	0.248355	0.582519	0.382958
SDGE DA			0.840877	0.207245	0.351876	0.65463
PGE HA				0.602852	0.337224	0.321445
SCE HA					0.658718	0.537085
SDGE HA						0.65934

Table 22: Cross-correlation between Day-Ahead and Hour-Ahead wind generation forecast errors

Correlation	Wind DA	Wind HA
Wind DA	0.9265339	0.1447009
Wind HA		0.8322981

Table 23: Cross-correlation between Day-Ahead load and wind generation forecast errors

	Wind DA			
Cross Correlation	Spring	Winter	Summer	Fall
PGE DA	0.063	0.123	0.003	-0.026
SCE DA	0.020	-0.010	0.054	0.101
SDGE DA	-0.050	0.010	-0.028	0.115

Table 24: Cross-correlation between Hour-Ahead load and wind generation forecast errors

	Wind HA			
Cross Correlation	Spring	Winter	Summer	Fall
PGE HA	0.028	0.032	0.007	0.021
SCE HA	-0.019	-0.023	-0.040	0.058
SDGE HA	-0.028	0.027	-0.014	-0.047

D-6 Calculation of Renewable Integration Costs

The ISO will calculate changes in the costs of renewable integration as components of its 33% RPS integration studies. The formulas used to determine those costs will be included in subsequent iterations of this technical appendix, and are likely to include as components changes in variable costs between benchmark cases and RPS cases as well as changes in certain capital costs associated with integration requirements.

[TO BE COMPLETED]

SECTION E

This section reviews the empirical analysis being conducted by the ISO to measure current generation and other resource capabilities and properties of the current system dispatch solutions, and compare these results to the results of operational studies modeling future system conditions.

E-1 Overview of Empirical Analysis of ISO Data

The ISO provides substantial data on market performance, renewable production and operational conditions on an ongoing basis. The performance of the markets and other relevant production data is presented and analyzed in several ISO daily, quarterly and annual reports. See also the review on “Public Market Information” in the BPM on Market Instruments.⁴⁸ The ISO is also considering the publication of renewable production forecast data to the markets.⁴⁹

Daily and weekly market pricing and procurement data and performance evaluation are available here – <http://www.caiso.com/205c/205cb4c74bc40.html> and here – <http://oasis.caiso.com/mrtu-oasis/?doframe=true&serverurl=http%3a%2f%2ffrpt09%2eoa%2ecaiso%2ecom%3a8000&volume=OASIS>.

Daily renewable energy production is available here – <http://www.caiso.com/green/renewrpt/DailyRenewablesWatch.pdf>.

Quarterly market reports by the Department of Market Monitoring are available here – <http://www.caiso.com/2425/2425f4d463570.html>.

Annual market performance reports by the Department of Market Monitoring) are available here – <http://www.caiso.com/1c5d/1c5dcc0465120.html>.

In addition to this existing analysis, the ISO will periodically provide data relevant to renewable integration, which could include analysis of public data, such as frequency of negative or high prices (greater than bid cap) real-time prices, or new types of analysis, such as the inventories of ramp rates, start-up times and regulation ramp rates of the existing fleet (in the 20% RPS Study) and the analysis of dispatch capability described in this section.

⁴⁸ Available at <http://www.caiso.com/17ba/17baa8bc1ce20.html>.

⁴⁹ This will be considered as part of the Phase 3 data release initiative.

E-2 Analysis of Historical ISO Data on Operational Capability

In the 20% RPS study (Section 4), the ISO conducted three measurements of the historical 5 minutes load-following capability of the generation fleet. For each measurement, the ISO used a determination of the 5-minute “upper limit” and “lower limit” of each resource automatically calculated through the RTED software based on ramp rates, upper operating limits, and any other unit operating constraints. The “last cleared value” refers to the last dispatch operating target (DOT) for the interval, $t-5$.

Upward load-following capability

The first measurement is of upward load-following capability between each two 5-minute intervals, $t - 5$ and t .

Upward capability =

(upper limit – last cleared value), if

(upper limit – last cleared value > 0), and

(last cleared value > 0).

Figure 37 shows this measurement graphically.

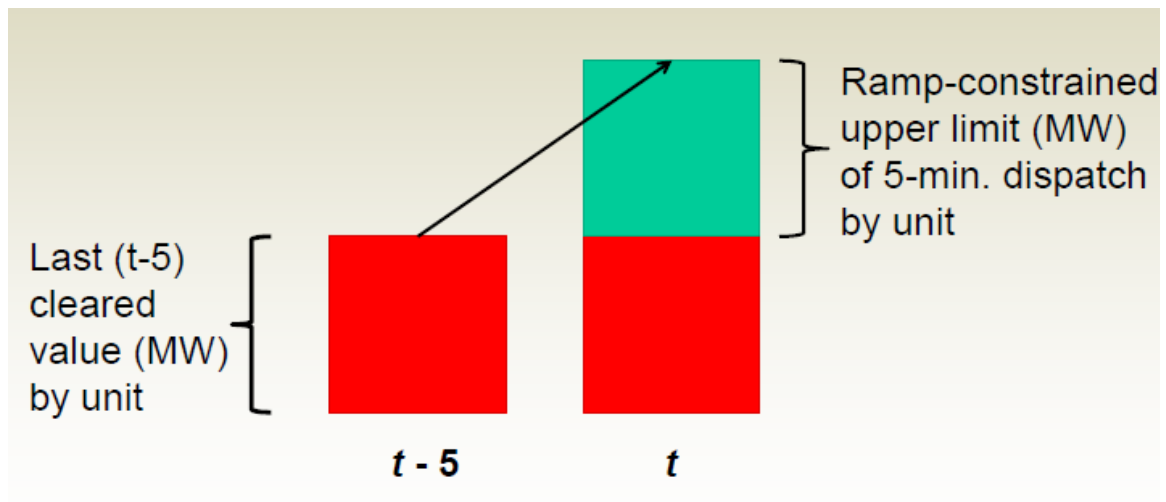

Figure 37: Measurement of 5-minute load following up capability

Downward load-following capability

The downward load-following capability is measured both as constrained by self-schedules and not constrained.

Downward capability not limited by self-schedules =

$$\begin{aligned} & (\text{last cleared value} - \text{lower limit}), \text{ if} \\ & \quad (\text{last cleared value} - \text{lower limit} > 0) \text{ and} \\ & \quad (\text{last cleared value} > 0). \end{aligned}$$

Downward capability limited by self-schedules =

$$\begin{aligned} & (\text{last cleared value} - \max(\text{lower limit}, \text{self schedule})), \text{ if} \\ & \quad (\text{last cleared value} - \max(\text{lower limit}, \text{self schedule}) > 0) \text{ and} \\ & \quad (\text{last cleared value} > 0). \end{aligned}$$

Note that this measurement of self-schedule constrained downward dispatch capability will be based on historical dispatch data. To the extent that additional dispatchability becomes available through changes in the ISO unit commitment algorithm (e.g., to enhance modeling of multi-stage generation) or through regulatory or contractual changes (e.g., to QF contracts), the results would change accordingly.

Regulation 5-minute Ramp Capability of Bid-in Capacity

To provide a measurement of the potential total Regulation capability in the historical dispatch solutions, the ISO has measured for every dispatch interval, for every IFM committed resource, the bid-in MW in regulation up or regulation down as limited by 5-minute Regulation ramp rate.⁵⁰ The hourly summary over the resources is follows:

Regulation Up capability = SUM over all IFM-committed resources,
[Min{(Bid-in Regulation Up (MW)), (5 min× Regulation Ramp Rate (MW/min))}],

and

Regulation Down capability = SUM over all IFM-committed resources,
[Min{(Bid-in Regulation Down (MW)), (5 min× Regulation Ramp Rate (MW/min))}].

⁵⁰ For an inventory of Regulation Ramp Rates, see 20% RPS Study (August 2010), Table 4.2, pg. 70.

E-3 Comparison of Historical Data and Simulation Results

This section will provide further analytical details to support the discussion in the 20% RPS Study (August 2010), Section 4, on how to compare the simulated results with ISO historical data on fleet capability.

[TO BE COMPLETED]

References

D.C. Barr, “The Use of a Data Historian to Extend Plant Life”, Life management of power plants, 12-14 December 1994, Conference Publication No. 401.0 IEEE 1994.

California Energy Commission (CEC). (2010). *Research Evaluation of Wind Generation, Solar Generation, and Storage Impact on the California Grid*. Prepared by KEMA, Inc., CEC-500-2009-XXX.

California ISO. (updated periodically). *Business Practice Manual for Billing and Settlements*. Available at <http://www.caiso.com/17ba/17baa8bc1ce20.html>.

California ISO. (updated periodically). *Business Practice Manual for Market Instruments*. Available at <http://www.caiso.com/17ba/17baa8bc1ce20.html>.

California ISO. (updated periodically). *Business Practice Manual for Market Operations*. Available at <http://www.caiso.com/17ba/17baa8bc1ce20.html>.

California ISO, *Annual Report on Market Issues and Performance, 2009* (April 2010), available at <http://www.caiso.com/2777/277789c42ac70.html>.

CAISO, *Revised Analysis of June 2008 – June 2009 Forecast Service Provider RFB Performance*, March 25, 2010, available at <http://www.caiso.com/2765/2765e6ad327c0.pdf>.

California ISO, Technical Bulletin, 2009-06-05, Market Optimization Details, June 16, 2009, Revised November 19, 2009, available at <http://www.caiso.com/23cf/23cfe2c91d880.pdf>.

California ISO. (2007). *Integration of Renewable Resources: transmission and operating issues and recommendations for integrating renewable resources on the California ISO-controlled grid*. Available at <http://www.caiso.com/1ca5/1ca5a7a026270.pdf>.

California Public Utilities Commission (CPUC). (2010). *RPS Quarterly Report (Q4 2009)*. Available at <http://www.cpuc.ca.gov/NR/rdonlyres/52BFA25E-0D2E-48C0-950C-9C82BFEEF54C/0/FourthQuarter2009RPSLegislativeReportFINAL.pdf>.

California Wind Energy Collaborative. (2006). *California Renewables Portfolio Standard Renewable Generation Integration Cost Analysis MULTI-YEAR ANALYSIS RESULTS*. California Energy Commission, PIER. Publication number CEC-500-2006-064.

GE Consulting, New York State Energy Research and Development Authority, “The Effects of Integrating Wind Power on Transmission System Planning, Reliability, and

Operations," available at
http://www.nyserda.org/publications/wind_integration_report.pdf

GE Consulting, Ontario Power Authority, Independent Electricity System Operator, Canadian Wind Energy Association, "Ontario Wind Integration Study," available at
http://www.powerauthority.on.ca/Storage/28/2321_OPA_Report_final.pdf ;

GE Consulting, Electrical Reliability Council of Texas, "Analysis of Wind Generation Impact on ERCOT Ancillary Services Requirements," available at
http://www.ercot.com/news/presentations/2008/Wind_Generation_Impact_on_Ancillary_Services_-_GE_Study.zip.

Kavalec, C. a. (2009). *California Energy Demand 2010-2020, Adopted Forecast*. California Energy Commission. CEC-200-2009-012-CMF. Available at
<http://www.energy.ca.gov/2009publications/CEC-200-2009-012/CEC-200-2009-012-CMF.PDF>.

Makarov, et al., "Operational Impacts of Wind Generation on California Power Systems," *IEEE Transactions on Power Systems*, Vol. 24, No. 2, (May 2009).

NERC. (2009). *Special Report: Accommodating High Levels of Variable Generation*. Available at http://www.nerc.com/files/IVGTF_Report_041609.pdf.

Contributors

The following people contributed or reviewed aspects of these appendices.

California ISO

Udi Helman
Mark Rothleder
Clyde Loutan
Shucheng Liu
Grant Rosenblum
June Xie
Hong Zhou

Professor Benjamin Hobbs
*California ISO Market Surveillance
Committee &
The Johns Hopkins University*

GE Energy Consulting

Sundar Venkataraman
Gary Jordan
Richard Piwko
Lavelle Freeman

Pacific Northwest National Laboratory

Jian Ma
Yuri Makarov

PLEXOS

Tao Guo
Wenxiong Huang
Eric Toolson

Nexant

Anupama Pandey
Barney Speckman
Paul Worhach

33% RPS Modeling Working Group

*[Participants not already mentioned
above]*

Antonio Alvarez, PG&E
Natasha Bray, SCE*
Susannah Churchill, CPUC
Jack Ellis, WPTF
Mohan Kondragunta, SCE
Mark Minick, SCE
Dariush Shirmohammadi, CalWEA
Alissa Sevrioukova, SCE*
Keith White, CPUC
Kevin Woodruff, TURN

*SCE modeling leads